



Village of Bayside
9075 N Regent Road
Board of Trustees Meeting
September 22, 2022
Village Board Room, 6:00pm

BOARD OF TRUSTEES AGENDA

PLEASE TAKE NOTICE that a meeting of the Bayside Village Board will be held at the Village Hall of the Village of Bayside, 9075 N. Regent Road, Bayside, Wisconsin in addition to virtually. Public can access this meeting of the Village Board by phone or by computer. The phone number is: **+1 312 626 6799**. The Zoom Meeting code is: **864 3357 0342** and the Passcode is: **623906**. <http://bitly.ws/ufvd> Persons desiring to speak in the remote format during Agenda Item III, Citizens and Delegations, should register twenty-four hours in advance by calling (414) 206-3915. The following items of business will be discussed and possibly acted upon:

I. CALL TO ORDER AND ROLL CALL

II. PLEDGE OF ALLEGIANCE

III. CITIZENS AND DELEGATIONS

Open to any citizen who wishes to speak on items not on the agenda. Please note there may be limited discussion on the information received, however, no action will be taken. Please state your name and address for the record.

IV. CONSENT AGENDA

Upon request of any Trustee, any item may be removed from the Consent Agenda for separate consideration.

A. Approval of:

1. Summary of Claims for August 11, 2022 through September 14, 2022 in the amount of \$359,715.
2. August 2022 Financial Statement.
3. Board of Trustees meeting minutes, August 11, 2022.
4. August 2022 Community Impact Report.
5. Right-of-way License Agreement with 8580 N Fielding Road.
6. Raze/repair order for 9121 N. Tennyson Drive.
7. Purchase of 2023 Ford Police Interceptor Utility AWD.
8. Grant award from Wisconsin DATCP for Household Hazardous Waste Clean Sweep Program in the amount of \$6,000.
9. Grant award from Wisconsin DATCP for Rx Allocation Clean Sweep Program in the amount of \$3,100.
10. Resolution 22-___, A Resolution to Amend the 2022 Annual Program Budget.
11. Resolution 22-___, A Resolution Authorizing the Village of Bayside to file the Urban Forestry Grant Application.
12. Proclamation Honoring Chief Douglas Larsson for 48 Years of Law

13. Enforcement Service.
Proclamation Honoring Bryan Herbst for 34 Years of Service.

V. BUSINESS AGENDA

A. COMMITTEE AND COMMISSION REPORTS

1. Public Safety Committee

- a. Swearing In of Police Officer Zachary Bell.
- b. Discussion/action on Proclamation Recognizing Bayside Communication Center Telecommunicator Jordan Trevisan for Life Saving Efforts.
- c. Discussion/action on August 2022 Communications Center Report.
- d. Discussion/action on August 2022 Police Department Report.

2. Public Works Committee

- a. Discussion/action on August 2022 Department of Public Works Report.
- b. Discussion/action on Green Solutions Funding Agreement G980005P111: Bayside Village Hall Bioswale.
- c. Discussion/update on 2022 Capital Projects.

3. North Shore Health Department

4. North Shore Fire Department

- a. Discussion/action on Resolution 22-___, A Resolution Approving the 2023 North Shore Fire Department Fees for Service Schedule.
- b. Discussion/action on Resolution 22-___, In the Matter of Authorizing an Exception to the Levy Limits for Charges for the North Shore Fire Department Pursuant to 2005 Wisconsin Act 484.

5. Finance and Administration Committee

- a. Discussion/action on August 2022 Administrative Services Report.
- b. Resolution 22-___, Resolution Authorizing the Partial Redemption of Special Assessment B Bonds, Series 2013A Dated May 16, 2013 and Special Assessment B Bonds, Series 2015A Dated May 7, 2015.
- c. Discussion/action on Information Technology Services Agreement with Village of Brown Deer.
- d. Discussion/action on Information Technology Services Agreement with Village of Shorewood.

6. Board of Zoning Appeals

- a. Discussion/action on the request for a special exception by Katie and Derreck Rose for a fence at the property located at 824 E Hermitage Rd, contrary to Section 104-125(c).
- b. Discussion/action on the request for a special exception by Colin and Jenny White for a fence at the property located at 1400 E Bay Point Rd, contrary to Section 104-125(j).
- c. Discussion/action on the request for a special exception by Kathleen and Thomas Roozen for a fence at the property located at 9126 N Meadowlark Ln, contrary to Section 104-125(k).

7. Architectural Review Committee

8. Plan Commission

9. Library Board

- a. Discussion/action on July and August 2022 North Shore Library Report.

VI. VILLAGE PRESIDENT'S REPORT

VII. VILLAGE MANAGER'S REPORT

VIII. VILLAGE ATTORNEY'S REPORT

IX. MISCELLANEOUS BUSINESS BY THE TRUSTEES AS MAY PROPERLY BE BROUGHT BEFORE THE BOARD

X. ADJOURNMENT

Upon reasonable notice, efforts will be made to accommodate the needs of disabled individuals through appropriate aids and services. Contact Village Hall at 414-206-3915. It is possible that members of and possibly a quorum of members of other Boards, Commissions, or Committees of the Village may be in attendance in the above stated meeting to gather information; no action will be taken by any other Boards, Commissions, or Committees of the Village except by the Board, Commission, or Committee noticed above. Agendas and minutes are available on the Village website (www.baysidewi.gov)



Village of Bayside
9075 N Regent Road
Board of Trustees Meeting
September 22, 2022
Village Board Room, 6:00pm

**BOARD OF TRUSTEES
SUPPLEMENTAL AGENDA NOTES**

I. CALL TO ORDER AND ROLL CALL

II. PLEDGE OF ALLEGIANCE

III. CITIZENS AND DELEGATIONS

IV. CONSENT AGENDA

A. Approval of:

- 1. Summary of Claims for August 11, 2022 through September 14, 2022 in the amount of \$359,715.**
- 2. August 2022 Financial Statement.**

Included in the packet is the August 2022 Financial Statement. Revenues and expenditures are on track year-to-date. **Approval is recommended.**

- 3. Board of Trustees meeting minutes, August 11, 2022.**
- 4. August 2022 Community Impact Report.**

Included in the packet is the August 2022 Community Impact Report. Of significant note, the average time to complete Access Bayside requests is 2.2 days, 5 days faster than 2021. **Approval is recommended.**

5. Right-of-way License Agreement with 8580 N Fielding Road.

The tree located at 8580 N Fielding Road was scheduled to be removed as part of the 2022 Tree Removal Project. The property owner has requested to take full responsibility for the tree even though it is in the Village right-of-way. The right-of-way License Agreement signed by the property owner is included in the packet. **Approval is recommended.**

6. Raze/repair order for 9121 N. Tennyson Drive.

Village staff, Bayside Police Department, the Village Building Inspector, and the North Shore Health Department met with the owner of the home following a Board of Zoning Appeals case which brought light to this issue. Prior to the Board of Zoning Appeals meeting, the Village had not received a complaint about the condition of the home and due to foliage and landscape, much of the home is screened from the street. Officer Sarah Kadulski has been working with the homeowner and this is the next step in the process.

Whenever the building inspector determines that any building or structure is so old, dilapidated or has become so out of repair as to be dangerous, unsafe, insanitary or otherwise unfit for

human habitation, occupancy or use, and so that it would be unreasonable to repair the same, the inspector shall recommend to the village board an order be sent to the owner to raze and remove all or part thereof, or if such structure can be made safe and sanitary by repairs, is at the owner's option. Such orders and proceedings shall be as provided in Wis. Stats. § 66.0413. The building inspector's findings are included in the raze/repair order for the home at 9121 N Tennyson Drive. **Approval is recommended.**

7. Purchase of 2023 Ford Police Interceptor Utility AWD.

The 2023 Ford Police Interceptor Utility AWD vehicle is included in the 2023 budget. Due to supply chain shortages, the Department is requesting the vehicle be ordered prior to the approved budget in order to receive the vehicle in 2023. **Approval is recommended.**

- 8. Grant award from Wisconsin DATCP for Household Hazardous Waste Clean Sweep Program in the amount of \$6,000.**
- 9. Grant award from Wisconsin DATCP for Rx Allocation Clean Sweep Program in the amount of \$3,100.**

The Village was awarded a \$6,000 grant for the collection of household hazardous waste and a \$3,100 grant for the collection of prescription drugs from the Wisconsin DATCP. **Approval is recommended.**

10. Resolution 22- ____, A Resolution to Amend the 2022 Annual Program Budget.

The proposed amendment is necessary to reflect current revenues and expenditures as authorized by the Village Board throughout 2022 as well as address housekeeping amendments. The 2022 budget remains balanced. **Approval is recommended.**

11. Resolution 22- ____, A Resolution Authorizing the Village of Bayside to file the Urban Forestry Grant Application.

The attached resolution authorizes the Village to submit a request to the Wisconsin DNR for a grant in the amount of \$25,000 for working in the Village's urban forest, specifically completing a tree inventory and pruning right-of-way trees. **Approval is recommended.**

- 12. Proclamation Honoring Chief Douglas Larsson for 48 Years of Law Enforcement Service.**
- 13. Proclamation Honoring Bryan Herbst for 34 years of Service.**
- 14. State of Wisconsin Department of Military Affairs Public Safety Answering Point NextGen9-1-1 Services Wisconsin Participation Agreement.**

The Department of Military Affairs (DMA) recently contracted with AT&T to provide a statewide Emergency Services IP based Network (ESInet) for PSAPs to implement NextGen9-1-1 services in Wisconsin. To ease the onboarding process and outlining the system requirements, a Wisconsin NextGen9-1-1 Participation Agreement has been developed for all PSAPs interested in joining the AT&T ESInet for NextGen9-1-1 services.

The attached Participation Agreement outlines the expectations of DMA, AT&T, and PSAPs utilizing the statewide NextGen9-1-1 system. Once an Agreement has been signed by all three parties, the planning and transition process for migrating the PSAP to the AT&T ESInet would begin. **Approval is recommended.**

V. BUSINESS AGENDA

A. COMMITTEE AND COMMISSION REPORTS

1. Public Safety Committee

a. Swearing In of Police Officer Zachary Bell.

Zachary Bell joined the Bayside Police Department on Tuesday, September 6. Officer Bell completed the Police Academy through Milwaukee Area Technical College. He also has prior law enforcement experience with the City of Kenosha Police Department. Welcome Officer Bell!

b. Discussion/action on Proclamation Recognizing Bayside Communication Center Telecommunicator Jordan Trevisan for Life Saving Efforts.

On July 27, 2022, Bayside Communication Center Telecommunicator Jordan Trevisan answered a call of a 2-year-old who was not breathing and did not have a pulse after a near-drowning experience. Due to Jordan's immediate action and recognizing the severity of the medical emergency, the 2-year-old's life was saved. **Approval is recommended.**

c. Discussion/action on August 2022 Communications Center Report.

Included in the packet is the August 2022 Communications Center Report. Of significant note, the Center has been training and preparing the Emergency Medical Dispatching system that is set to go live on September 21, 2022. **Approval is recommended.**

d. Discussion/action on August 2022 Police Department Report.

Included in the packet is the August 2022 Police Department Report. Of significant note, Officer Cranny completed his field training and has been assigned to midnight shift. **Approval is recommended.**

2. Public Works Committee

a. Discussion/action on August 2022 Department of Public Works Report.

Included the packet is the August 2022 Department of Public Works Report. Of significant note, the Department focused on the stormwater/culvert project. There have been 16 culverts replaced and 4,750 feet of ditching completed. **Approval is recommended.**

b. Discussion/action on Green Solutions Funding Agreement G980005P111: Bayside Village Hall Bioswale.

The agreement outlines a green infrastructure project between the Village and Milwaukee Metropolitan Sewerage District to clean the ditch along the west side of the Village Hall property from the Public Works building to Fairy Chasm Road and construct a bioswale in the area. This item was previously budgeted and will now be funded through a grant in the amount of \$98,637. **Approval is recommended.**

c. Discussion/update on 2022 Capital Projects.

2022 Stormwater and Road Project: The crew began marking and cutting driveway and cross culverts the week of July 11. Ditching and driveway culvert work began the week of July 18. The crew removed driveway approaches and built ramps for residents the week of July 25. The crew will continue to perform culvert replacements and ditching through the end of September. Milling and repaving is tentatively scheduled for the first week in October. As always, work is weather dependent.

Sanitary Sewer Lining: Cleaning and televising began the week of August 29. Lining work began the week of September 12. There are approximately 10,000 feet of main line and approximately 60 manholes.

Tennyson Stormwater Management Infrastructure Project: The bid opening was held and was approved by the Board of Trustees at the August 18 board meeting. Site preparation will begin September 22 with road work starting around September 29. Work will continue through October and be completed by mid-November. As always, work is weather dependent.

East Bayside Sanitary Sewer Relief System: The Board of Trustees approved the design and construction services proposal at the June 23 Board of Trustees meeting. The scope of work includes extending the relief sewer to the intersection of Fairy Chasm Road and Tennyson drive to address persistent sewer capacity issues in the area.

Brown Deer Road Sanitary Sewer Infrastructure Study: The Board of Trustees approved the workplan at the June 23 Board of Trustees meeting. The workplan includes identifying sewer capacity restrictions and developing engineered solutions to address the restrictions in the 8-block area bound by Brown Deer Road, Krause Place, Iroquois Road, and Navajo Road. The scope of work includes creating a computer model of the sewers in the area.

Public Right-of-way Tree Removal: The Village has contracted Wallace Tree and Landscape, Inc. to remove an additional 108 trees within public right-of-way that have a yellow ribbon around them. Roughly half of the trees have been removed and the contractor is back in the Village to remove the second half.

3. North Shore Health Department

4. North Shore Fire Department

a. Discussion/action on Resolution 22- ___, A Resolution Approving the 2023 North Shore Fire Department Fees for Service Schedule.

Attached is an updated fee schedule approved by the North Shore Fire Department of Directors at its most recent meeting as part of the 2023 budget process. Annually, the North Shore Fire Department reviews and establishes fees for services provided. The fee schedule requires approval by the member communities in order to be enacted. **Approval is recommended.**

b. Discussion/action on Resolution 22- ___, In the Matter of Authorizing an Exception to the Levy Limits for Charges for the North Shore Fire Department Pursuant to 2005 Wisconsin Act 484.

Attached is a resolution authorizing an exception to the levy limit charges for the North Shore Fire Department pursuant to 2005 Wisconsin Act 484. In order for any community within the North Shore Fire Department service area to utilize the levy exemption, all member agency communities need to approve this same resolution. The Village Board, as well as all the member communities, have approved this same resolution for a number of years. This resolution does not

financially bind the Village to utilize the levy exemption. The Village has utilized this exemption in the past and is anticipated to use the exemption again as part of the 2023 budget process.

Approval is recommended.

5. Finance and Administration Committee

a. Discussion/action on August 2022 Administrative Services Report.

Included in the packet is the August 2022 Administrative Services Report. Of significant note, the Partisan Primary Election was held with a 45.15% voter turnout with 52 new registered voters.

Approval is recommended.

b. Resolution 22- ____, Resolution Authorizing the Partial Redemption of Special Assessment B Bonds, Series 2013A Dated May 16, 2013 and Special Assessment B Bonds, Series 2015A Dated May 7, 2015.

Attached is a resolution authorizing the partial redemption of special assessment B bonds, series 2013A dated May 16, 2013 and special assessment B bonds, series 2015A dated May 7, 2015. This resolution is in regard to the pre-payment by property owners for the municipal water projects in 2013 and 2015. The resolution requires the Village Board to approve this in order for the bond holders to be repaid based on monies that have been received from property owners for the pre-payments. Currently, this resolution authorizes the pre-pay for a total of \$10,000 of the 2013A bonds as well as \$40,000 for the 2015A bonds. **Approval is recommended.**

c. Discussion/action on Information Technology Services Agreement with Village of Brown Deer.

The attached agreement outlines the Information Technology services the Bayside IT Department will provide to the Village of Brown Deer for a 3-year contract. The agreement outlines 1,040 hours of work annually with additional payment for any amount of hours over 1,040 hours. **Approval is recommended.**

d. Discussion/action on Information Technology Services Agreement with Village of Shorewood.

The attached agreement outline the full-time Information Technology service provided by the Bayside IT Department to the Village of Shorewood for a 3-year contract with a 2-year renewal beginning January 1, 2023. **Approval is recommended.**

6. Board of Zoning Appeals

a. Discussion/action on the request for a special exception by Katie and Derreck Rose for a fence at the property located at 824 E Hermitage Rd, contrary to Section 104-125(c).

b. Discussion/action on the request for a special exception by Colin and Jenny White for a fence at the property located at 1400 E Bay Point Rd, contrary to Section 104-125(j).

c. Discussion/action on the request for a special exception by Kathleen and Thomas Roozen for a fence at the property located at 9126 N Meadowlark Ln, contrary to Section 104-125(k).

The Board of Zoning Appeals will consider the request for a special exception on Thursday, September 22, 2022, at 5:00pm and forward a recommendation to the Board of Trustees.

7. **Architectural Review Committee**
8. **Plan Commission**
9. **Library Board**
 - a. **Discussion/action on July and August 2022 North Shore Library Report.**

Included in the packet is the July and August 2022 North Shore Library Report. Of significant note, usage numbers are continually increasing toward pre-pandemic numbers. **Approval is recommended.**

- VI. **VILLAGE PRESIDENT'S REPORT**
- VII. **VILLAGE MANAGER'S REPORT**
- VIII. **VILLAGE ATTORNEY'S REPORT**
- IX. **MISCELLANEOUS BUSINESS BY THE TRUSTEES AS MAY PROPERLY BE BROUGHT BEFORE THE BOARD**
- X. **ADJOURNMENT**

CHECK REGISTER FOR VILLAGE OF BAYSIDE

CHECK DATE 08/11/2022 - 09/14/2022

Check Date	Check	Vendor Name	Amount
Bank GEN GENERAL POOLED CHECKING			
08/11/2022	38114	AFLAC	13.80
08/11/2022	38115	AMAZON/SYNCB	3,123.52
08/11/2022	38116	BAKER & TAYLOR	4,535.33
08/11/2022	38117	BAKER TILLY VIRCHOW KRAUSE LL	2,600.00
08/11/2022	38118	BUILDING SERVICES INC	7,656.54
08/11/2022	38119	DAVIS & KUELTHAU S.C.	827.95
08/11/2022	38120	Dolan Consulting Group, LLC	95.00
08/11/2022	38121	FARMERS IMPLEMENT LLC	91.64
08/11/2022	38122	FRANK GILLITZER ELECTRIC CO	309.88
08/11/2022	38123	GOVERNMENT FINANCE OFFICERS	460.00
08/11/2022	38124	Graphicolor	310.60
08/11/2022	38125	HUMPHREY SERVICE PARTS INC	134.70
08/11/2022	38126	IMPACT ACQUISITIONS, LLC	7,654.70
08/11/2022	38127	JAMES MAE RENTALS LLC	125.00
08/11/2022	38128	KUJAWA ENTERPRISES INC	7,300.00
08/11/2022	38129	LANNON STONE PRODUCTS	2,153.71
08/11/2022	38130	LIESENER SOILS INC	1,560.00
08/11/2022	38131	LINCOLN CONTRACTORS SUPPLY	1,645.00
08/11/2022	38132	MARK K COLLINGS	1,304.91
08/11/2022	38133	MERIT TITLE	2,620.26
08/11/2022	38134	OCCUPATIONAL HEALTH CENTERS O	71.00
08/11/2022	38135	PEDERSON, ANDREW	798.22
08/11/2022	38136	POBLOCKI SIGN COMPANY LLC	464.00
08/11/2022	38137	PREMIUM WATERS INC.	96.64
08/11/2022	38138	PROPHOENIX CORPORATION	12,600.00
08/11/2022	38139	R J SIEGEL	54.00
08/11/2022	38140	RHONDA GOULD	1,749.28
08/11/2022	38141	RINGCENTRAL, INC.	37.47
08/11/2022	38142	ROSS STELTER	1.38
08/11/2022	38143	SAFEBUILT LLC Lockbox #88135	6,289.18
08/11/2022	38144	SECURIAN FINANCIAL GROUP	1,292.86
08/11/2022	38145	SEELCLICKFIX INC	2,765.07
08/11/2022	38146	SPECTRUM BUSINESS	256.72
08/11/2022	38147	TEAMSTERS LOCAL UNION # 200	490.00
08/11/2022	38148	TOMAS J & MARY M GOULET TRUST	11,603.46
08/11/2022	38149	UniFirst Corporation	26.80
08/11/2022	38151	WE ENERGIES -	7,245.53
08/11/2022	38152	WI SCTF	1,158.63
08/11/2022	38153	WISCONSIN DOCUMENT IMAGING	305.07
Total 08/11/2022:			91,827.85
08/26/2022	38157	AFLAC	13.80
08/26/2022	38158	WI SCTF	1,158.63
Total 08/26/2022:			1,172.43
08/31/2022	30(E)	CARTER, JULIE	1,483.10
08/31/2022	31(E)	EFTPS	75,403.38
08/31/2022	32(E)	EMPOWER-GREATWEST	7,914.77
08/31/2022	33(E)	NORTH SHORE BANK	200.00
08/31/2022	34(E)	US BANK	33,695.35
08/31/2022	38(E)	WI DEPARTMENT OF REVENUE	12,801.47
Total 08/31/2022:			131,498.07
09/01/2022	38159	AMANDA CAIVANO	29.24
09/01/2022	38160	BACKGROUND ONLINE	99.90
09/01/2022	38161	BARCO PRODUCTS	698.00
09/01/2022	38162	BATZNER PEST CONTROL	87.00
09/01/2022	38163	BAYSIDE GARDEN CENTER	129.59
09/01/2022	38164	BUILDING SERVICES INC	30,698.61
09/01/2022	38165	CITY OF MEQUON	1,201.89
09/01/2022	38166	Clark Dietz	2,380.00
09/01/2022	38167	DAILY REPORTER PUBLISHING CO	114.55
09/01/2022	38168	DAVIS & KUELTHAU S.C.	300.00
09/01/2022	38169	DELTA DENTAL	270.46
09/01/2022	38170	FRIENDS OF THE NORTH SHORE LI	209.40
09/01/2022	38171	GREATAMERICA FINANCIAL SERVIC	107.00
09/01/2022	38172	HERBST OIL	6,437.70
09/01/2022	38173	HORIZON PEST MANAGEMENT LLC	456.00
09/01/2022	38174	HUMPHREY SERVICE PARTS INC	371.59
09/01/2022	38175	JOE DE BELAK PLUMBING COMPANY	1,282.00
09/01/2022	38176	JUST MECHANICAL	970.00
09/01/2022	38177	KUJAWA ENTERPRISES INC	4,739.88

CHECK REGISTER FOR VILLAGE OF BAYSIDE

CHECK DATE 08/11/2022 - 09/14/2022

Check Date	Check	Vendor Name	Amount
Bank GEN GENERAL POOLED CHECKING			
09/01/2022	38178	LANGE ENTERPRISES INC	75.34
09/01/2022	38179	LANNON STONE PRODUCTS	3,485.31
09/01/2022	38180	LV ENTERPRISES LLC	2,304.00
09/01/2022	38181	MEA- SEW	30.00
09/01/2022	38182	MITEL	811.94
09/01/2022	38183	NORTH SHORE CHAMBER OF COMMER	95.00
09/01/2022	38184	PACKERLAND RENT-A-MAT INC.	41.81
09/01/2022	38185	PREMIUM WATERS INC.	193.28
09/01/2022	38186	PROFESSIONAL ID CARDS INC.	36.50
09/01/2022	38187	Swank Motion Pictures	1,045.00
09/01/2022	38188	TOTAL ENERGY SYSTEMS LLC	3,819.22
09/01/2022	38189	UniFirst Corporation	26.80
09/01/2022	38190	VERIZON CONNECT FLEET USA LLC	177.12
09/01/2022	38191	WALLACE TREE AND LANDSCAPE	22,356.00
09/01/2022	38192	WAYSIDE NURSERIES	442.90
09/01/2022	38193	WE ENERGIES	2,336.45
Total 09/01/2022:			87,859.48
09/09/2022	39(E)	EFTPS	35,623.38
09/09/2022	40(E)	EMPOWER-GREATWEST	3,768.39
09/09/2022	41(E)	NORTH SHORE BANK	100.00
09/09/2022	42(E)	WI DEPARTMENT OF REVENUE	5,984.45
09/09/2022	38194	AFLAC	13.80
09/09/2022	38195	RINGCENTRAL, INC.	218.52
09/09/2022	38196	TEAMSTERS LOCAL UNION # 200	490.00
09/09/2022	38197	WI SCTF	1,158.63
Total 09/09/2022:			47,357.17
GEN TOTALS:			
Total of 90 Checks:			359,715.00
Less 0 Void Checks:			0.00
Total of 90 Disbursements:			359,715.00

REVENUE AND EXPENDITURE REPORT FOR VILLAGE OF BAYSIDE

Balance As of 08/31/2022

GL Number	Description	2022 Amended Budget	YTD Balance 08/31/2022	Activity For 08/31/2022	Available Balance 08/31/2022	% Bdgt Used
Fund: 10 GENERAL FUND						
Account Category: Revenues						
TAXES						
10-00000-41100	PROPERTY TAXES	3,239,467.00	3,239,466.68	447,072.90	0.32	100.00
10-00000-41300	INTEREST ON DELINQUENT TAXES	12,000.00	11,229.57	0.00	770.43	93.58
10-00000-41500	PAYMENT IN LIEU OF TAXES	47,036.00	14,525.67	0.00	32,510.33	30.88
	TAXES	3,298,503.00	3,265,221.92	447,072.90	33,281.08	98.99
INTERGOVERNMENTAL						
10-00000-43210	COMMUNITY DEVELOPMENT BLOCK GR	5,598.00	4,651.94	0.00	946.06	83.10
10-00000-43225	PUBLIC SAFETY COMMUNICATION AD	99,409.00	99,438.00	0.00	(29.00)	100.03
10-00000-43235	NORTH SHORE LIBRARY REVENUE	19,521.00	19,521.00	0.00	0.00	100.00
10-00000-43410	STATE SHARED REVENUES	60,297.00	9,044.63	0.00	51,252.37	15.00
10-00000-43415	VIDEO SERVICE PROVIDER AID	14,470.00	14,470.35	0.00	(0.35)	100.00
10-00000-43510	RECYCLING GRANT	25,770.00	25,704.27	0.00	65.73	99.74
10-00000-43520	STATE FIRE INSURANCE	0.00	23,606.17	0.00	(23,606.17)	100.00
10-00000-43530	EXEMPT COMPUTER AID	15,160.00	15,159.62	0.00	0.38	100.00
10-00000-43535	PERSONAL PROPERTY AID	1,738.00	1,737.78	0.00	0.22	99.99
10-00000-43540	STATE TRANSPORTATION AIDS	415,180.00	314,775.91	0.00	100,404.09	75.82
10-00000-43545	ST 32 HIGHWAY AIDS	17,013.00	8,506.52	0.00	8,506.48	50.00
10-00000-43555	INTERGOVERNMENTAL GRANT	0.00	1,330.74	0.00	(1,330.74)	100.00
10-00000-43600	EXPENDITURE RESTRAINT	82,745.00	82,745.20	0.00	(0.20)	100.00
	INTERGOVERNMENTAL	756,901.00	620,692.13	0.00	136,208.87	82.00
LICENSES & PERMITS						
10-00000-44100	OPERATORS LICENSE	1,000.00	715.00	0.00	285.00	71.50
10-00000-44120	LIQUOR LICENSE	2,400.00	2,880.00	0.00	(480.00)	120.00
10-00000-44140	CIGARETTE LICENSE	200.00	300.00	0.00	(100.00)	150.00
10-00000-44220	ANIMAL LICENSES	1,227.00	1,039.36	49.00	187.64	84.71
10-00000-44300	CABLE FRANCHISE FEES	65,000.00	38,373.18	12,769.50	26,626.82	59.04
10-00000-44415	ARC APPLICATION FEES	2,000.00	3,897.00	225.00	(1,897.00)	194.85
10-00000-44420	OCCUPANCY PERMITS	300.00	1,300.00	0.00	(1,000.00)	433.33
10-00000-44435	TRANSIENT MERCHANT PERMIT	0.00	190.00	0.00	(190.00)	100.00
10-00000-44440	ALARM COMPANY/PERMIT FEES	0.00	450.00	0.00	(450.00)	100.00
10-00000-44460	BUILDING PERMITS	65,000.00	105,570.02	18,062.70	(40,570.02)	162.42
10-00000-44480	VACANT PROPERTY FEE	0.00	1,500.00	500.00	(1,500.00)	100.00
10-00000-44495	EXCAVATION/RIGHT OF WAY/PRIVLE	10,000.00	11,830.00	1,150.00	(1,830.00)	118.30
10-00000-44525	FILL PERMIT	0.00	570.00	0.00	(570.00)	100.00
10-00000-44530	RUMMAGE SALE PERMITS	240.00	105.00	30.00	135.00	43.75
10-00000-44535	DUMPSTER PERMITS	3,000.00	3,940.00	450.00	(940.00)	131.33
10-00000-44540	SIGN PERMITS	200.00	290.00	90.00	(90.00)	145.00
10-00000-44550	CONDITIONAL USE APPLICATION	600.00	300.00	0.00	300.00	50.00
10-00000-44555	BOARD OF ZONING APPEALS FEES	500.00	4,500.00	1,500.00	(4,000.00)	900.00
10-00000-44560	TREE PROGRAM	5,000.00	3,600.00	0.00	1,400.00	72.00
10-00000-44570	SPECIAL EVENT PERMITS	50.00	275.00	75.00	(225.00)	550.00
	LICENSES & PERMITS	156,717.00	181,624.56	34,901.20	(24,907.56)	115.89
FINES & FORFEITURES						
10-00000-43220	COURT REVENUE	0.00	2,695.40	0.00	(2,695.40)	100.00
10-00000-45100	FINES & FORFEITURES-NSMC	35,000.00	23,418.98	2,033.39	11,581.02	66.91
10-00000-45105	FINES & FORFEITURES-BAYSIDE SD	0.00	9,460.47	1,904.35	(9,460.47)	100.00
10-00000-45125	NOTARY/FINGER	100.00	135.10	25.00	(35.10)	135.10

REVENUE AND EXPENDITURE REPORT FOR VILLAGE OF BAYSIDE

Balance As of 08/31/2022

GL Number	Description	2022 Amended Budget	YTD Balance 08/31/2022	Activity For 08/31/2022	Available Balance 08/31/2022	% Bdgt Used
Fund: 10 GENERAL FUND						
Account Category: Revenues						
FINES & FORFEITURES						
	FINES & FORFEITURES	35,100.00	35,709.95	3,962.74	(609.95)	101.74
PUBLIC CHARGES FOR SERVIC						
10-00000-43215	POLICE REVENUE	0.00	25.00	0.00	(25.00)	100.00
10-00000-46110	PROPERTY STATUS REVENUE	4,000.00	4,000.00	200.00	0.00	100.00
10-00000-46120	PUBLICATION FEES	200.00	50.00	0.00	150.00	25.00
10-00000-46125	LEGAL SERVICE INVOICING	0.00	16,279.72	0.00	(16,279.72)	100.00
10-00000-46130	DATA SALES	550.00	156.50	0.00	393.50	28.45
10-00000-46310	SPECIAL PICKUPS	8,000.00	8,538.00	2,539.00	(538.00)	106.73
10-00000-46315	MULCH DELIVERIES	6,000.00	5,495.01	200.00	504.99	91.58
10-00000-46330	WELL PERMIT/ABANDONMENT FEES	300.00	1,270.00	520.00	(970.00)	423.33
10-00000-46400	EQUIPMENT RENTAL- SEWER FUND	20,000.00	20,000.00	0.00	0.00	100.00
10-00000-46415	EQUIPMENT RENTAL- STORMWATER F	20,000.00	20,000.00	0.00	0.00	100.00
10-00000-46710	PARK FACILITY RENTAL & PROGRAM	800.00	1,416.00	327.00	(616.00)	177.00
10-00000-46715	PUBLIC WORKS SERVICE REVENUE	300.00	2,825.00	0.00	(2,525.00)	941.67
	PUBLIC CHARGES FOR SERVIC	60,150.00	80,055.23	3,786.00	(19,905.23)	133.09
MISC REVENUE						
10-00000-48100	INTEREST	65,000.00	63,865.37	20,811.69	1,134.63	98.25
10-00000-48120	REALIZED/UNREALIZED GAIN/LOSS	0.00	(151,789.77)	(14,726.91)	151,789.77	100.00
10-00000-48200	MISCELLANEOUS REVENUE	500.00	4,001.57	0.00	(3,501.57)	800.31
10-00000-48210	COPIES	0.00	1,589.82	19.50	(1,589.82)	100.00
10-00000-48220	FALSE ALARM FEES	2,500.00	1,990.00	360.00	510.00	79.60
10-00000-48230	RECYCLING PROCEEDS	4,000.00	28,243.29	3,361.00	(24,243.29)	706.08
10-00000-48240	CREDIT CARD REVENUE	7,000.00	4,244.45	2,749.65	2,755.55	60.64
10-00000-48310	EQUIPMENT SALE PROCEEDS	16,000.00	485.20	0.00	15,514.80	3.03
10-00000-48500	DONATIONS	8,000.00	9,106.07	845.59	(1,106.07)	113.83
	MISC REVENUE	103,000.00	(38,264.00)	13,420.52	141,264.00	37.15
	Revenues	4,410,371.00	4,145,039.79	503,143.36	265,331.21	93.98
Account Category: Expenditures						
GENERAL GOVERNMENT						
10-51000-51100	WAGES FT	245,449.00	179,306.47	21,409.96	66,142.53	73.05
10-51000-51170	HEALTH INSURANCE BUYOUT	1,950.00	1,333.36	166.66	616.64	68.38
10-51000-51190	DENTAL INSURANCE BUYOUT	204.00	90.54	11.31	113.46	44.38
10-51000-51200	TRUSTEE WAGES	8,400.00	5,600.00	700.00	2,800.00	66.67
10-51000-51250	ELECTION WAGES	5,245.00	3,210.00	1,248.00	2,035.00	61.20
10-51000-51300	ELECTIONS SUPPLIES	4,485.00	3,646.70	132.24	838.30	81.31
10-51000-51500	WISCONSIN RETIREMENT SYSTEM	14,669.00	11,478.65	1,391.65	3,190.35	78.25
10-51000-51510	SOCIAL SECURITY	18,942.00	14,727.55	1,661.29	4,214.45	77.75
10-51000-51520	LIFE INSURANCE	900.00	304.78	35.74	595.22	33.86
10-51000-51530	HEALTH INSURANCE	25,492.00	20,520.75	2,047.36	4,971.25	80.50
10-51000-51540	DENTAL INSURANCE	815.00	413.70	33.23	401.30	50.76
10-51000-51600	TRAVEL & LODGING	0.00	0.00	(951.86)	0.00	0.00
10-51000-51800	RECRUITMENT	650.00	643.73	0.00	6.27	99.04
10-51000-52080	LEGAL SERVICES-MISC	2,000.00	(2,946.72)	0.00	4,946.72	(147.34)
10-51000-52100	CONTRACTUAL SERVICES	25,799.00	11,097.88	984.17	14,701.12	43.02
10-51000-52110	LEGAL COUNSEL - CONTRACTED	61,545.00	31,645.43	300.00	29,899.57	51.42
10-51000-52140	AUDIT SERVICES	21,930.00	21,875.13	1,905.37	54.87	99.75

REVENUE AND EXPENDITURE REPORT FOR VILLAGE OF BAYSIDE

Balance As of 08/31/2022

GL Number	Description	2022 Amended Budget	YTD Balance 08/31/2022	Activity For 08/31/2022	Available Balance 08/31/2022	% Bdgt Used
Fund: 10 GENERAL FUND						
Account Category: Expenditures						
GENERAL GOVERNMENT						
10-51000-52170	PUBLIC HEALTH SERVICES	29,842.00	15,100.25	0.00	14,741.75	50.60
10-51000-52190	ASSESSOR SERVICES	24,900.00	24,900.00	3,735.00	0.00	100.00
10-51000-52210	TELECOMMUNICATIONS	3,058.00	3,718.05	95.89	(660.05)	121.58
10-51000-52250	COMPUTER SUPPORT	1,000.00	0.00	0.00	1,000.00	0.00
10-51000-52260	BENEFIT ADMINISTRATIVE FEES	2,550.00	2,549.46	0.00	0.54	99.98
10-51000-52290	BANKING FEES	1,400.00	433.27	10.00	966.73	30.95
10-51000-52300	MATERIALS & SUPPLIES	3,044.00	2,573.38	0.00	470.62	84.54
10-51000-52380	FINANCIAL ADVISING SERVICES	2,000.00	1,200.00	0.00	800.00	60.00
10-51000-53000	ADMINISTRATIVE	800.00	887.88	0.00	(87.88)	110.99
10-51000-53100	OFFICE SUPPLIES	4,000.00	2,311.39	310.60	1,688.61	57.78
10-51000-53110	POSTAGE	5,000.00	0.00	0.00	5,000.00	0.00
10-51000-53210	DUES & SUBSCRIPTIONS	5,886.00	2,090.42	0.00	3,795.58	35.52
10-51000-53220	TRAINING, SAFETY & CERTS	8,255.00	3,975.03	1,750.08	4,279.97	48.15
10-51000-53230	WELLNESS	397.00	0.00	0.00	397.00	0.00
10-51000-53240	PUBLICATIONS/PRINTING	410.00	60.41	0.00	349.59	14.73
10-51000-53500	EQUIPMENT REPLACEMENT	260,270.00	69,798.38	32,489.72	190,471.62	26.82
10-51000-53900	PUBLIC RELATIONS	100.00	0.00	0.00	100.00	0.00
10-51000-55000	CONTINGENCY	58,026.00	0.00	0.00	58,026.00	0.00
10-51000-55100	GENERAL LIABILITY	40,260.00	40,349.16	0.00	(89.16)	100.22
10-51000-55110	AUTO LIABILITY	4,857.00	4,802.00	0.00	55.00	98.87
10-51000-55120	BOILER INSURANCE	781.00	726.00	0.00	55.00	92.96
10-51000-55130	WORKERS COMPENSATION	50,734.00	29,023.39	0.00	21,710.61	57.21
10-51000-55150	COMMERCIAL CRIME POLICY	181.00	175.45	0.00	5.55	96.93
10-51000-55160	PROPERTY INSURANCE	7,099.00	7,256.00	0.00	(157.00)	102.21
10-51000-55170	PUBLIC OFFICIAL BONDS	7,650.00	7,547.02	0.00	102.98	98.65
10-51000-55910	MUNICIPAL CODE	4,000.00	2,001.99	0.00	1,998.01	50.05
GENERAL GOVERNMENT		964,975.00	524,426.88	69,466.41	440,548.12	54.35
POLICE						
10-52100-51100	WAGES FT	1,130,301.00	673,807.70	90,917.99	456,493.30	59.61
10-52100-51110	OVERTIME	27,000.00	46,814.99	7,465.95	(19,814.99)	173.39
10-52100-51160	HOLIDAY PAY	38,404.00	1,072.96	0.00	37,331.04	2.79
10-52100-51170	HEALTH INSURANCE BUYOUT	12,600.00	0.00	0.00	12,600.00	0.00
10-52100-51180	SHIFT DIFFERENTIAL PAY	4,500.00	1,650.00	125.00	2,850.00	36.67
10-52100-51190	DENTAL INSURANCE BUYOUT	227.00	37.76	0.00	189.24	16.63
10-52100-51500	WISCONSIN RETIREMENT SYSTEM	145,105.00	75,146.82	9,977.78	69,958.18	51.79
10-52100-51510	SOCIAL SECURITY	94,771.00	54,358.06	7,369.91	40,412.94	57.36
10-52100-51520	LIFE INSURANCE	964.00	600.68	92.68	363.32	62.31
10-52100-51530	HEALTH INSURANCE	182,845.00	67,644.23	8,446.13	115,200.77	37.00
10-52100-51540	DENTAL INSURANCE	3,430.00	1,782.70	173.82	1,647.30	51.97
10-52100-51800	RECRUITMENT	1,190.00	882.93	495.00	307.07	74.20
10-52100-52090	HOUSE OF CORRECTION FEES	300.00	0.00	0.00	300.00	0.00
10-52100-52100	CONTRACTUAL SERVICES	33,207.00	21,435.13	709.71	11,771.87	64.55
10-52100-52110	LEGAL COUNSEL-CONTRACTED	24,618.00	14,360.57	0.00	10,257.43	58.33
10-52100-52130	LEGAL COUNSEL-PERSONNEL	19,000.00	19,109.80	0.00	(109.80)	100.58
10-52100-52150	MADACC	1,550.00	1,396.86	0.00	153.14	90.12
10-52100-52210	TELECOMMUNICATIONS	5,196.00	4,541.39	144.89	654.61	87.40
10-52100-52250	COMPUTER SUPPORT SERVICES	5,000.00	189.98	0.00	4,810.02	3.80

REVENUE AND EXPENDITURE REPORT FOR VILLAGE OF BAYSIDE

Balance As of 08/31/2022

GL Number	Description	2022 Amended Budget	YTD Balance 08/31/2022	Activity For 08/31/2022	Available Balance 08/31/2022	% Bdgt Used
Fund: 10 GENERAL FUND						
Account Category: Expenditures						
POLICE						
10-52100-52260	BENEFIT ADMINISTRATIVE FEES	0.00	20.50	0.00	(20.50)	100.00
10-52100-52300	MATERIALS & SUPPLIES	4,310.00	2,183.89	311.24	2,126.11	50.67
10-52100-52310	FLEET MAINTENANCE	7,000.00	2,195.09	122.46	4,804.91	31.36
10-52100-53100	OFFICE SUPPLIES	1,000.00	5.00	0.00	995.00	0.50
10-52100-53110	POSTAGE	800.00	66.64	18.73	733.36	8.33
10-52100-53210	DUES & SUBSCRIPTIONS	990.00	854.22	0.00	135.78	86.28
10-52100-53220	TRAINING, SAFETY & CERTIFICATI	4,500.00	2,487.36	(400.00)	2,012.64	55.27
10-52100-53230	AMMUNITION	3,600.00	759.76	0.00	2,840.24	21.10
10-52100-53300	UNIFORM SUPPLIES	8,650.00	7,630.66	0.00	1,019.34	88.22
10-52100-53400	FUEL MAINTENANCE	16,500.00	16,375.52	2,112.08	124.48	99.25
10-52100-55190	GASB 45 OBLIGATIONS	31,644.00	30,664.00	(17,297.37)	980.00	96.90
POLICE		1,809,202.00	1,048,075.20	110,786.00	761,126.80	57.93
NORTH SHORE FIRE DEPT						
10-52200-52240	NORTH SHORE FIRE DEPARTMENT	874,313.00	661,122.00	0.00	213,191.00	75.62
NORTH SHORE FIRE DEPT		874,313.00	661,122.00	0.00	213,191.00	75.62
BUILDING INSPECTION						
10-52400-51100	WAGES FT	20,000.00	20,000.00	0.00	0.00	100.00
10-52400-52500	BUILDING INSPECTIONS	35,750.00	52,678.74	6,289.18	(16,928.74)	147.35
BUILDING INSPECTION		55,750.00	72,678.74	6,289.18	(16,928.74)	130.37
DEPT OF PUBLIC WORKS						
10-53000-51100	WAGES FT	285,285.00	215,173.47	23,563.22	70,111.53	75.42
10-53000-51110	OVERTIME	4,050.00	1,450.72	0.00	2,599.28	35.82
10-53000-51170	HEALTH INSURANCE BUYOUT	0.00	90.88	90.88	(90.88)	100.00
10-53000-51500	WISCONSIN RETIREMENT SYSTEM	18,658.00	12,033.06	1,208.98	6,624.94	64.49
10-53000-51510	SOCIAL SECURITY	22,801.00	14,740.41	1,716.93	8,060.59	64.65
10-53000-51520	LIFE INSURANCE	977.00	672.33	71.26	304.67	68.82
10-53000-51530	HEALTH INSURANCE	85,551.00	64,402.47	5,475.95	21,148.53	75.28
10-53000-51540	DENTAL INSURANCE	1,835.00	1,360.28	48.73	474.72	74.13
10-53000-51800	RECRUITMENT	121.00	120.95	0.00	0.05	99.96
10-53000-52000	FACILITY MAINTENANCE & SUPPLIE	22,723.00	22,582.90	1,819.00	140.10	99.38
10-53000-52010	CLEANING & JANITORIAL SERVICES	11,541.00	7,298.80	617.53	4,242.20	63.24
10-53000-52020	HVAC MAINTENANCE	4,200.00	0.00	0.00	4,200.00	0.00
10-53000-52100	CONTRACTUAL SERVICES	39,505.00	20,892.12	5,298.78	18,612.88	52.88
10-53000-52160	ENGINEERING	20,000.00	8,300.00	10,000.00	11,700.00	41.50
10-53000-52200	UTILITIES	44,500.00	23,940.56	5,001.67	20,559.44	53.80
10-53000-52210	TELECOMMUNICATIONS	2,300.00	856.08	35.30	1,443.92	37.22
10-53000-52260	BENEFIT ADMINISTRATIVE FEES	0.00	8.52	0.00	(8.52)	100.00
10-53000-52300	MATERIALS & SUPPLIES	9,500.00	7,165.46	4.74	2,334.54	75.43
10-53000-52310	FLEET MAINTENANCE	32,500.00	13,423.74	1,091.16	19,076.26	41.30
10-53000-52330	TOOLS	1,500.00	1,360.72	150.88	139.28	90.71
10-53000-53100	OFFICE SUPPLIES	150.00	5.00	0.00	145.00	3.33
10-53000-53210	DUES & SUBSCRIPTIONS	500.00	215.00	30.00	285.00	43.00
10-53000-53220	TRAINING, SAFETY & CERTIFICATI	1,950.00	1,139.86	0.00	810.14	58.45
10-53000-53300	UNIFORM SUPPLIES	1,800.00	2,125.14	1,784.32	(325.14)	118.06
10-53000-53340	WINTER OPERATIONS	40,000.00	21,272.53	0.00	18,727.47	53.18
10-53000-53400	FUEL MAINTENANCE	20,000.00	22,645.48	100.50	(2,645.48)	113.23

REVENUE AND EXPENDITURE REPORT FOR VILLAGE OF BAYSIDE

Balance As of 08/31/2022

GL Number	Description	2022 Amended Budget	YTD Balance 08/31/2022	Activity For 08/31/2022	Available Balance 08/31/2022	% Bdgt Used
Fund: 10 GENERAL FUND						
Account Category: Expenditures						
DEPT OF PUBLIC WORKS						
10-53000-53600	EQUIPMENT RENTAL	9,000.00	5,935.00	0.00	3,065.00	65.94
10-53000-53700	TIPPING FEES	66,000.00	38,784.73	18,415.48	27,215.27	58.76
10-53000-53770	YARD WASTE TUB GRINDING	8,500.00	0.00	0.00	8,500.00	0.00
10-53000-53900	PUBLIC RELATIONS	100.00	0.00	0.00	100.00	0.00
10-53000-54000	STREET MAINTENANCE	7,700.00	115.99	0.00	7,584.01	1.51
10-53000-54500	SIGNAGE	2,679.00	790.84	75.34	1,888.16	29.52
10-53000-54600	FORESTRY & LANDSCAPING	7,000.00	0.00	0.00	7,000.00	0.00
10-53000-54650	TREE DISEASE MITIGATION	15,000.00	30,228.49	30,228.49	(15,228.49)	201.52
DEPT OF PUBLIC WORKS		787,926.00	539,131.53	106,829.14	248,794.47	68.42
NORTH SHORE LIBRARY						
10-55100-52270	NORTH SHORE LIBRARY	160,077.00	160,077.00	0.00	0.00	100.00
NORTH SHORE LIBRARY		160,077.00	160,077.00	0.00	0.00	100.00
PARKS						
10-55200-51100	WAGES FT	5,200.00	4,120.00	400.00	1,080.00	79.23
10-55200-51510	SOCIAL SECURITY	398.00	315.18	30.60	82.82	79.19
10-55200-52300	MATERIALS & SUPPLIES	500.00	0.75	0.00	499.25	0.15
10-55200-52350	COMMUNITY EVENTS	15,000.00	4,144.23	2,709.92	10,855.77	27.63
PARKS		21,098.00	8,580.16	3,140.52	12,517.84	40.67
Expenditures		4,673,341.00	3,014,091.51	296,511.25	1,659,249.49	64.50
Fund 10 - GENERAL FUND:						
TOTAL REVENUES		4,410,371.00	4,145,039.79	503,143.36	265,331.21	
TOTAL EXPENDITURES		4,673,341.00	3,014,091.51	296,511.25	1,659,249.49	
NET OF REVENUES & EXPENDITURES:		(262,970.00)	1,130,948.28	206,632.11	(1,393,918.28)	
BEG. FUND BALANCE		1,614,328.23	1,614,328.23			
END FUND BALANCE		1,351,358.23	2,745,276.51			

REVENUE AND EXPENDITURE REPORT FOR VILLAGE OF BAYSIDE

Balance As of 08/31/2022

GL Number	Description	2022 Amended Budget	YTD Balance 08/31/2022	Activity For 08/31/2022	Available Balance 08/31/2022	% Bdgt Used
Fund: 20 SANITARY SEWER FUND						
Account Category: Revenues						
PUBLIC CHARGES FOR SERVIC						
20-00000-46410	RESIDENTIAL SEWER	808,000.00	784,770.00	0.00	23,230.00	97.13
20-00000-46420	COMMERCIAL SEWER	70,000.00	54,212.87	0.00	15,787.13	77.45
20-00000-46425	POLICE LEASE REVENUE	10,502.00	10,502.00	0.00	0.00	100.00
	PUBLIC CHARGES FOR SERVIC	888,502.00	849,484.87	0.00	39,017.13	95.61
MISC REVENUE						
20-00000-48100	INTEREST	0.00	185.20	69.75	(185.20)	100.00
20-00000-48200	MISCELLANEOUS REVENUE	0.00	3,500.00	0.00	(3,500.00)	100.00
	MISC REVENUE	0.00	3,685.20	69.75	(3,685.20)	100.00
	Revenues	888,502.00	853,170.07	69.75	35,331.93	96.02
Account Category: Expenditures						
GENERAL SEWER						
20-51000-51100	WAGES FT	142,869.00	58,962.57	4,539.30	83,906.43	41.27
20-51000-51110	OVERTIME	1,500.00	1,071.10	0.00	428.90	71.41
20-51000-51170	HEALTH INSURANCE BUYOUT	500.00	333.31	41.67	166.69	66.66
20-51000-51190	DENTAL INSURANCE BUYOUT	54.00	30.21	3.77	23.79	55.94
20-51000-51500	WISCONSIN RETIREMENT SYSTEM	7,355.00	2,732.95	391.60	4,622.05	37.16
20-51000-51510	SOCIAL SECURITY	8,699.00	3,177.26	458.74	5,521.74	36.52
20-51000-51520	LIFE INSURANCE	307.00	97.51	11.21	209.49	31.76
20-51000-51530	HEALTH INSURANCE	23,236.00	4,928.23	339.23	18,307.77	21.21
20-51000-51540	DENTAL INSURANCE	498.00	111.99	3.78	386.01	22.49
20-51000-52100	CONTRACTUAL SERVICES	275,364.00	215,016.77	1,932.55	60,347.23	78.08
20-51000-52140	AUDIT SERVICES	4,115.00	4,114.06	358.34	0.94	99.98
20-51000-52160	ENGINEERING	50,000.00	34,892.00	8,615.00	15,108.00	69.78
20-51000-52200	UTILITIES	7,000.00	2,321.55	(1,824.35)	4,678.45	33.17
20-51000-52210	TELECOMMUNICATIONS	240.00	106.73	0.00	133.27	44.47
20-51000-52260	BENEFIT ADMINISTRATIVE FEES	46.00	42.53	0.00	3.47	92.46
20-51000-52290	BANKING FEES	1,400.00	0.00	0.00	1,400.00	0.00
20-51000-52300	MATERIALS & SUPPLIES	2,000.00	47.45	0.00	1,952.55	2.37
20-51000-52310	FLEET MAINTENANCE	1,500.00	970.56	0.00	529.44	64.70
20-51000-52320	LIFT STATION MAINTENANCE	10,550.00	20,221.12	0.00	(9,671.12)	191.67
20-51000-52340	DIGGERS HOTLINE	2,200.00	2,136.00	0.00	64.00	97.09
20-51000-52380	FINANCIAL ADVISING SERVICES	2,000.00	0.00	0.00	2,000.00	0.00
20-51000-53110	POSTAGE	400.00	0.00	0.00	400.00	0.00
20-51000-53220	TRAINING, SAFETY & CERTIFICATI	2,400.00	0.00	0.00	2,400.00	0.00
20-51000-53400	FUEL MAINTENANCE	3,200.00	0.00	0.00	3,200.00	0.00
20-51000-53500	EQUIPMENT REPLACEMENT	1,000.00	0.00	0.00	1,000.00	0.00
20-51000-53600	EQUIPMENT RENTAL-GENERAL FUND	20,000.00	20,000.00	0.00	0.00	100.00
20-51000-55100	GENERAL LIABILITY INSURANCE	1,837.00	1,821.37	0.00	15.63	99.15
20-51000-55130	WORKERS COMPENSATION	1,664.00	952.17	0.00	711.83	57.22
20-51000-55150	COMMERCIAL CRIME POLICY	12.00	11.62	0.00	0.38	96.83
20-51000-55160	PROPERTY INSURANCE	2,789.00	2,789.00	0.00	0.00	100.00
20-51000-58010	CAPITAL PROJECTS	342,141.00	4,872.18	0.00	337,268.82	1.42
20-51000-58030	CAPITAL EQUIPMENT	111,000.00	8,640.50	0.00	102,359.50	7.78
	GENERAL SEWER	1,027,876.00	390,400.74	14,870.84	637,475.26	37.98
DEPRECIATION						

REVENUE AND EXPENDITURE REPORT FOR VILLAGE OF BAYSIDE

Balance As of 08/31/2022

GL Number	Description	2022 Amended Budget	YTD Balance 08/31/2022	Activity For 08/31/2022	Available Balance 08/31/2022	% Bdgt Used
Fund: 20 SANITARY SEWER FUND						
Account Category: Expenditures						
DEPRECIATION						
20-53000-57000	DEPRECIATION	3,138.00	0.00	0.00	3,138.00	0.00
	DEPRECIATION	3,138.00	0.00	0.00	3,138.00	0.00
DEBT						
20-58100-56170	PRINCIPAL REDEMPTION - CWFL	82,717.00	0.00	0.00	82,717.00	0.00
20-58100-56180	PRINCIPAL REDEMPTION - BOND	175,000.00	0.00	0.00	175,000.00	0.00
20-58100-56210	INTEREST - BOND	68,140.00	36,022.50	12,058.75	32,117.50	52.87
20-58100-56260	INTEREST-CLEAN WATER FUND LOAN	5,031.00	3,004.33	0.00	2,026.67	59.72
	DEBT	330,888.00	39,026.83	12,058.75	291,861.17	11.79
	Expenditures	1,361,902.00	429,427.57	26,929.59	932,474.43	31.53
Fund 20 - SANITARY SEWER FUND:						
	TOTAL REVENUES	888,502.00	853,170.07	69.75	35,331.93	
	TOTAL EXPENDITURES	1,361,902.00	429,427.57	26,929.59	932,474.43	
	NET OF REVENUES & EXPENDITURES:	(473,400.00)	423,742.50	(26,859.84)	(897,142.50)	
	BEG. FUND BALANCE	2,808,872.16	2,808,872.16			
	END FUND BALANCE	2,335,472.16	3,232,614.66			

REVENUE AND EXPENDITURE REPORT FOR VILLAGE OF BAYSIDE

Balance As of 08/31/2022

GL Number	Description	2022 Amended Budget	YTD Balance 08/31/2022	Activity For 08/31/2022	Available Balance 08/31/2022	% Bdgt Used
Fund: 22 STORMWATER UTILITY FUND						
Account Category: Revenues						
PUBLIC CHARGES FOR SERVIC						
22-00000-46405	RESIDENTIAL STORMWATER	400,626.00	390,353.70	0.00	10,272.30	97.44
22-00000-46425	COMMERCIAL STORMWATER	154,449.00	70,052.40	0.00	84,396.60	45.36
22-00000-46430	RIGHT-OF-WAY MANAGEMENT	15,000.00	20,052.32	950.00	(5,052.32)	133.68
	PUBLIC CHARGES FOR SERVIC	570,075.00	480,458.42	950.00	89,616.58	84.28
	Revenues	570,075.00	480,458.42	950.00	89,616.58	84.28
Account Category: Expenditures						
DEPT OF PUBLIC WORKS						
22-53000-51100	WAGES FT	131,310.00	68,708.36	14,678.25	62,601.64	52.33
22-53000-51110	OVERTIME	950.00	1,028.88	1,028.88	(78.88)	108.30
22-53000-51170	HEALTH INSURANCE BUYOUT	500.00	333.33	41.67	166.67	66.67
22-53000-51190	DENTAL INSURANCE BUYOUT	54.00	30.29	3.80	23.71	56.09
22-53000-51500	WISCONSIN RETIREMENT SYSTEM	7,134.00	3,917.45	1,013.64	3,216.55	54.91
22-53000-51510	SOCIAL SECURITY	8,439.00	4,506.46	1,150.11	3,932.54	53.40
22-53000-51520	LIFE INSURANCE	307.00	111.72	31.80	195.28	36.39
22-53000-51530	HEALTH INSURANCE	22,179.00	8,889.91	2,985.90	13,289.09	40.08
22-53000-51540	DENTAL INSURANCE	475.00	164.76	27.34	310.24	34.69
22-53000-52100	CONTRACTUAL SERVICES	9,762.00	2,067.97	604.50	7,694.03	21.18
22-53000-52110	LEGAL COUNCIL-CONTRACTED	1,000.00	827.95	0.00	172.05	82.80
22-53000-52140	AUDIT SERVICES	1,931.00	1,930.40	168.14	0.60	99.97
22-53000-52160	ENGINEERING	82,000.00	63,517.22	(22,231.85)	18,482.78	77.46
22-53000-52200	UTILITY EXPENSES	2,400.00	701.42	0.00	1,698.58	29.23
22-53000-52210	TELECOMMUNICATIONS	100.00	0.00	0.00	100.00	0.00
22-53000-52260	BENEFIT ADMINISTRATIVE FEES	46.00	42.53	0.00	3.47	92.46
22-53000-52300	MATERIALS & SUPPLIES	2,500.00	2,303.97	61.68	196.03	92.16
22-53000-52320	LIFT STATION MAINTENANCE	2,000.00	500.00	0.00	1,500.00	25.00
22-53000-52380	FINANCIAL ADVISING SERVICES	2,000.00	0.00	0.00	2,000.00	0.00
22-53000-53220	TRAINING, SAFETY & CERTIFICATI	1,000.00	0.00	0.00	1,000.00	0.00
22-53000-53270	CULVERT MATERIALS	27,895.00	23,382.12	5,694.52	4,512.88	83.82
22-53000-53280	LANDSCAPING MATERIALS	35,757.00	11,953.71	0.00	23,803.29	33.43
22-53000-53290	EXCAVATION AND DISPOSAL	15,000.00	0.00	0.00	15,000.00	0.00
22-53000-53400	FUEL MAINTENANCE	2,500.00	0.00	0.00	2,500.00	0.00
22-53000-53500	EQUIPMENT REPLACEMENT	0.00	(1,271.83)	0.00	1,271.83	100.00
22-53000-53600	EQUIPMENT RENTAL	20,000.00	20,000.00	0.00	0.00	100.00
22-53000-55100	GENERAL LIABILITY INSURANCE	2,265.00	2,246.13	0.00	18.87	99.17
22-53000-55130	WORKERS COMPENSATION	1,632.00	933.63	0.00	698.37	57.21
22-53000-55150	COMMERCIAL CRIME POLICY	12.00	11.63	0.00	0.37	96.92
22-53000-55160	PROPERTY INSURANCE	2,708.00	2,708.00	0.00	0.00	100.00
	DEPT OF PUBLIC WORKS	383,856.00	219,546.01	5,258.38	164,309.99	57.19
DEBT						
22-58100-56210	INTEREST - BOND	0.00	11,820.64	5,096.25	(11,820.64)	100.00
	DEBT	0.00	11,820.64	5,096.25	(11,820.64)	100.00
TRANS TO OTHER FUND						
22-59200-59000	ADMINISTRATIVE/TRANSFER TO	74,091.00	74,091.00	0.00	0.00	100.00
	TRANS TO OTHER FUND	74,091.00	74,091.00	0.00	0.00	100.00
CAPITAL PROJECTS						

REVENUE AND EXPENDITURE REPORT FOR VILLAGE OF BAYSIDE

Balance As of 08/31/2022

GL Number	Description	2022 Amended Budget	YTD Balance 08/31/2022	Activity For 08/31/2022	Available Balance 08/31/2022	% Bdgt Used
Fund: 22 STORMWATER UTILITY FUND						
Account Category: Expenditures						
CAPITAL PROJECTS						
22-53000-58010	CAPITAL PROJECTS	380,000.00	2,495.05	2,380.00	377,504.95	0.66
	CAPITAL PROJECTS	380,000.00	2,495.05	2,380.00	377,504.95	0.66
	Expenditures	837,947.00	307,952.70	12,734.63	529,994.30	36.75
Fund 22 - STORMWATER UTILITY FUND:						
	TOTAL REVENUES	570,075.00	480,458.42	950.00	89,616.58	
	TOTAL EXPENDITURES	837,947.00	307,952.70	12,734.63	529,994.30	
	NET OF REVENUES & EXPENDITURES:	(267,872.00)	172,505.72	(11,784.63)	(440,377.72)	
	BEG. FUND BALANCE	1,164,697.73	1,164,697.73			
	END FUND BALANCE	896,825.73	1,337,203.45			

REVENUE AND EXPENDITURE REPORT FOR VILLAGE OF BAYSIDE

Balance As of 08/31/2022

GL Number	Description	2022 Amended Budget	YTD Balance 08/31/2022	Activity For 08/31/2022	Available Balance 08/31/2022	% Bdgt Used
Fund: 23 COMM DEVELOPMENT AUTHORITY						
Account Category: Expenditures						
GENERAL GOVERNMENT						
23-51000-52300	PROFESSIONAL SERVICES	0.00	28,839.10	0.00	(28,839.10)	100.00
	GENERAL GOVERNMENT	0.00	28,839.10	0.00	(28,839.10)	100.00
	Expenditures	0.00	28,839.10	0.00	(28,839.10)	100.00
Fund 23 - COMM DEVELOPMENT AUTHORITY:						
	TOTAL REVENUES	0.00	0.00	0.00	0.00	
	TOTAL EXPENDITURES	0.00	28,839.10	0.00	(28,839.10)	
	NET OF REVENUES & EXPENDITURES:	0.00	(28,839.10)	0.00	28,839.10	
	BEG. FUND BALANCE	0.00	0.00			
	END FUND BALANCE	0.00	(28,839.10)			

REVENUE AND EXPENDITURE REPORT FOR VILLAGE OF BAYSIDE

Balance As of 08/31/2022

GL Number	Description	2022 Amended Budget	YTD Balance 08/31/2022	Activity For 08/31/2022	Available Balance 08/31/2022	% Bdgt Used
Fund: 26 PUBLIC SAFETY COMMUNICATIONS						
Account Category: Revenues						
TAXES						
26-00000-41100	PROPERTY TAXES	303,653.00	303,653.00	0.00	0.00	100.00
	TAXES	303,653.00	303,653.00	0.00	0.00	100.00
INTERGOVERNMENTAL						
26-00000-46220	INTERGOVERNMENTAL REVENUE	280,219.00	148,362.00	3,362.67	131,857.00	52.95
26-00000-47130	CONTRACT REVENUE	2,125,571.00	1,786,613.44	0.00	338,957.56	84.05
	INTERGOVERNMENTAL	2,405,790.00	1,934,975.44	3,362.67	470,814.56	80.43
MISC REVENUE						
26-00000-48100	CONSOLIDATED SERVICE BILLINGS	65,125.00	34,099.29	19,792.85	31,025.71	52.36
	MISC REVENUE	65,125.00	34,099.29	19,792.85	31,025.71	52.36
	Revenues	2,774,568.00	2,272,727.73	23,155.52	501,840.27	81.91
Account Category: Expenditures						
PUBLIC SAFETY COMM						
26-51000-51100	WAGES FT	1,534,221.00	923,126.22	112,519.03	611,094.78	60.17
26-51000-51110	OVERTIME	40,800.00	37,334.89	3,200.51	3,465.11	91.51
26-51000-51160	HOLIDAY PAY	29,632.00	20,368.60	3,474.08	9,263.40	68.74
26-51000-51170	HEALTH INSURANCE BUYOUT	3,000.00	3,249.99	458.33	(249.99)	108.33
26-51000-51190	DENTAL INSURANCE BUYOUT	453.00	166.14	26.43	286.86	36.68
26-51000-51500	WISCONSIN RETIREMENT SYSTEM	102,562.00	63,543.59	7,747.62	39,018.41	61.96
26-51000-51510	SOCIAL SECURITY	123,020.00	70,399.78	8,630.84	52,620.22	57.23
26-51000-51520	LIFE INSURANCE	2,564.00	1,755.41	224.61	808.59	68.46
26-51000-51530	HEALTH INSURANCE	385,603.00	232,689.62	24,556.26	152,913.38	60.34
26-51000-51540	DENTAL INSURANCE	7,973.00	4,996.62	332.20	2,976.38	62.67
26-51000-51800	RECRUITMENT	2,100.00	1,831.38	0.00	268.62	87.21
26-51000-52000	FACILITY MAINTENANCE & SUPPLIE	13,983.00	9,901.79	2,875.16	4,081.21	70.81
26-51000-52010	CLEANING & JANITORIAL SERVICES	11,386.00	8,136.05	876.36	3,249.95	71.46
26-51000-52100	CONTRACTUAL SERVICES	20,902.00	20,013.52	710.06	888.48	95.75
26-51000-52130	LEGAL COUNSEL-PERSONNEL	1,000.00	0.00	0.00	1,000.00	0.00
26-51000-52140	AUDIT SERVICES	1,931.00	1,930.41	168.15	0.59	99.97
26-51000-52200	UTILITIES	24,240.00	16,248.33	4,068.21	7,991.67	67.03
26-51000-52210	TELECOMMUNICATIONS	113,375.00	53,618.59	5,169.91	59,756.41	47.29
26-51000-52250	COMPUTER SUPPORT SERVICES	3,500.00	(416.25)	0.00	3,916.25	(11.89)
26-51000-52260	BENEFIT ADMINISTRATIVE FEES	879.00	860.04	0.00	18.96	97.84
26-51000-52300	MATERIALS & SUPPLIES	12,500.00	6,549.82	139.95	5,950.18	52.40
26-51000-52360	LICENSING & MAINTENANCE	210,080.00	21,362.72	12,600.00	188,717.28	10.17
26-51000-53100	OFFICE SUPPLIES	1,770.00	509.63	104.08	1,260.37	28.79
26-51000-53110	POSTAGE	500.00	0.00	0.00	500.00	0.00
26-51000-53210	DUES & SUBSCRIPTIONS	2,000.00	1,568.80	0.00	431.20	78.44
26-51000-53220	TRAINING, SAFETY & CERTIFICATI	8,000.00	1,704.00	815.00	6,296.00	21.30
26-51000-53300	CLOTHING/EMPLOYEE EXPENSES	220.00	217.00	0.00	3.00	98.64
26-51000-53500	EQUIPMENT REPLACEMENT	0.00	(40,641.57)	0.00	40,641.57	100.00
26-51000-53900	EMPLOYEE RECOGNITION	500.00	0.00	0.00	500.00	0.00
26-51000-55000	CONTINGENCY	5,238.00	5,237.24	0.00	0.76	99.99
26-51000-55100	GENERAL LIABILITY	4,920.00	4,878.80	0.00	41.20	99.16
26-51000-55130	WORKERS COMPENSATION	2,418.00	1,383.02	0.00	1,034.98	57.20
26-51000-55150	COMMERCIAL CRIME POLICY	102.00	98.30	0.00	3.70	96.37

REVENUE AND EXPENDITURE REPORT FOR VILLAGE OF BAYSIDE

Balance As of 08/31/2022

GL Number	Description	2022 Amended Budget	YTD Balance 08/31/2022	Activity For 08/31/2022	Available Balance 08/31/2022	% Bdgt Used
Fund: 26 PUBLIC SAFETY COMMUNICATIONS						
Account Category: Expenditures						
PUBLIC SAFETY COMM						
26-51000-55160	PROPERTY INSURANCE	3,760.00	3,760.00	0.00	0.00	100.00
	PUBLIC SAFETY COMM	2,675,132.00	1,476,382.48	188,696.79	1,198,749.52	55.19
TRANS TO OTHER FUND						
26-59217-59000	ADMINISTRATIVE/TRANSFER TO	99,438.00	99,438.00	0.00	0.00	100.00
	TRANS TO OTHER FUND	99,438.00	99,438.00	0.00	0.00	100.00
	Expenditures	2,774,570.00	1,575,820.48	188,696.79	1,198,749.52	56.80
Fund 26 - PUBLIC SAFETY COMMUNICATIONS:						
	TOTAL REVENUES	2,774,568.00	2,272,727.73	23,155.52	501,840.27	
	TOTAL EXPENDITURES	2,774,570.00	1,575,820.48	188,696.79	1,198,749.52	
	NET OF REVENUES & EXPENDITURES:	(2.00)	696,907.25	(165,541.27)	(696,909.25)	
	BEG. FUND BALANCE	411,015.77	411,015.77			
	END FUND BALANCE	411,013.77	1,107,923.02			

REVENUE AND EXPENDITURE REPORT FOR VILLAGE OF BAYSIDE

Balance As of 08/31/2022

GL Number	Description	2022 Amended Budget	YTD Balance 08/31/2022	Activity For 08/31/2022	Available Balance 08/31/2022	% Bdgt Used
Fund: 30 LONG TERM FINANCIAL FUND						
Account Category: Revenues						
TAXES						
30-00000-41100	PROPERTY TAXES	792,089.00	792,089.00	0.00	0.00	100.00
	TAXES	792,089.00	792,089.00	0.00	0.00	100.00
INTERGOVERNMENTAL						
30-00000-47115	B SERIES ADMIN FEE	11,541.00	0.00	0.00	11,541.00	0.00
	INTERGOVERNMENTAL	11,541.00	0.00	0.00	11,541.00	0.00
LICENSES & PERMITS						
30-00000-44350	CELL TOWER FEES	24,260.00	15,862.96	3,060.70	8,397.04	65.39
	LICENSES & PERMITS	24,260.00	15,862.96	3,060.70	8,397.04	65.39
MISC REVENUE						
30-00000-48100	INTEREST	500.00	0.00	0.00	500.00	0.00
30-00000-48300	NSFD	167,315.00	170,972.50	167,315.00	(3,657.50)	102.19
	MISC REVENUE	167,815.00	170,972.50	167,315.00	(3,157.50)	101.88
OTHER FINANCING SOURCES						
30-00000-49250	TRANSFER FROM STORMWATER FUND	74,091.00	74,091.00	0.00	0.00	100.00
	OTHER FINANCING SOURCES	74,091.00	74,091.00	0.00	0.00	100.00
	Revenues	1,069,796.00	1,053,015.46	170,375.70	16,780.54	98.43
Account Category: Expenditures						
DEBT						
30-58100-52150	MADACC	1,784.00	0.00	0.00	1,784.00	0.00
30-58100-52260	BENEFIT ADMINISTRATIVE FEES	1,400.00	0.00	0.00	1,400.00	0.00
30-58100-55950	PAYMENT TO ESCROW AGENT	0.00	1,800.00	0.00	(1,800.00)	100.00
30-58100-56100	2021A GENERAL OBLIGATION	125,000.00	0.00	0.00	125,000.00	0.00
30-58100-56110	NSFD STATION #5	160,000.00	160,000.00	0.00	0.00	100.00
30-58100-56140	UNFUNDED LIABILITY PRINCIPAL	27,373.00	27,372.86	0.00	0.14	100.00
30-58100-56180	PRINCIPAL- 2014 BOND	330,000.00	130,000.00	0.00	200,000.00	39.39
30-58100-56190	2016 GENERAL OBLIGATION	130,000.00	0.00	0.00	130,000.00	0.00
30-58100-56200	2018 GENERAL OBLIGATION	35,000.00	135,000.00	0.00	(100,000.00)	385.71
30-58100-56210	INTEREST ON BOND	165,037.00	109,363.11	17,898.75	55,673.89	66.27
30-58100-56230	UNFUNDED LIABILITY INTEREST	3,093.00	3,092.69	0.00	0.31	99.99
30-58100-56240	2021 B GO DEBT	20,000.00	0.00	0.00	20,000.00	0.00
	DEBT	998,687.00	566,628.66	17,898.75	432,058.34	56.74
	Expenditures	998,687.00	566,628.66	17,898.75	432,058.34	56.74
Fund 30 - LONG TERM FINANCIAL FUND:						
	TOTAL REVENUES	1,069,796.00	1,053,015.46	170,375.70	16,780.54	
	TOTAL EXPENDITURES	998,687.00	566,628.66	17,898.75	432,058.34	
	NET OF REVENUES & EXPENDITURES:	71,109.00	486,386.80	152,476.95	(415,277.80)	
	BEG. FUND BALANCE	487,297.78	487,297.78			
	END FUND BALANCE	558,406.78	973,684.58			

REVENUE AND EXPENDITURE REPORT FOR VILLAGE OF BAYSIDE

Balance As of 08/31/2022

GL Number	Description	2022 Amended Budget	YTD Balance 08/31/2022	Activity For 08/31/2022	Available Balance 08/31/2022	% Bdgt Used
Fund: 40 POLICE CAPITAL						
Account Category: Revenues						
TAXES						
40-00000-41100	PROPERTY TAXES	67,066.00	67,066.00	0.00	0.00	100.00
40-00000-41130	FIRE & RESCUE PROPERTY TAXES	40,336.00	40,336.00	0.00	0.00	100.00
	TAXES	107,402.00	107,402.00	0.00	0.00	100.00
INTERGOVERNMENTAL						
40-00000-43210	INTERGOVERNMENTAL GRANTS	0.00	2,019.22	0.00	(2,019.22)	100.00
	INTERGOVERNMENTAL	0.00	2,019.22	0.00	(2,019.22)	100.00
LICENSES & PERMITS						
40-00000-44350	CELL TOWER FEES	0.00	21,000.00	21,000.00	(21,000.00)	100.00
	LICENSES & PERMITS	0.00	21,000.00	21,000.00	(21,000.00)	100.00
	Revenues	107,402.00	130,421.22	21,000.00	(23,019.22)	121.43
Account Category: Expenditures						
CAPITAL PROJECTS						
40-91000-58010	CAPITAL PROJECTS	40,336.00	32,254.00	0.00	8,082.00	79.96
40-91000-58020	CAPITAL LEASE	10,502.00	10,502.00	0.00	0.00	100.00
40-91000-58030	CAPITAL EQUIPMENT	56,564.00	883.00	0.00	55,681.00	1.56
	CAPITAL PROJECTS	107,402.00	43,639.00	0.00	63,763.00	40.63
	Expenditures	107,402.00	43,639.00	0.00	63,763.00	40.63
Fund 40 - POLICE CAPITAL:						
	TOTAL REVENUES	107,402.00	130,421.22	21,000.00	(23,019.22)	
	TOTAL EXPENDITURES	107,402.00	43,639.00	0.00	63,763.00	
	NET OF REVENUES & EXPENDITURES:	0.00	86,782.22	21,000.00	(86,782.22)	
	BEG. FUND BALANCE	(64,986.85)	(64,986.85)			
	END FUND BALANCE	(64,986.85)	21,795.37			

REVENUE AND EXPENDITURE REPORT FOR VILLAGE OF BAYSIDE

Balance As of 08/31/2022

GL Number	Description	2022 Amended Budget	YTD Balance 08/31/2022	Activity For 08/31/2022	Available Balance 08/31/2022	% Bdgt Used
Fund: 41 DEPARTMENT OF PUBLIC WORKS						
Account Category: Revenues						
TAXES						
41-00000-41100	PROPERTY TAXES	125,000.00	125,000.00	0.00	0.00	100.00
	TAXES	125,000.00	125,000.00	0.00	0.00	100.00
PUBLIC CHARGES FOR SERVIC						
41-00000-46320	GARBAGE CONTAINER & FEES	5,000.00	9,869.23	(9,778.94)	(4,869.23)	197.38
41-00000-46725	MAILBOX REPLACEMENT	0.00	2,000.00	1,400.00	(2,000.00)	100.00
	PUBLIC CHARGES FOR SERVIC	5,000.00	11,869.23	(8,378.94)	(6,869.23)	237.38
MISC REVENUE						
41-00000-48200	MISCELLANEOUS REVENUE	0.00	29,512.40	0.00	(29,512.40)	100.00
	MISC REVENUE	0.00	29,512.40	0.00	(29,512.40)	100.00
	Revenues	130,000.00	166,381.63	(8,378.94)	(36,381.63)	127.99
Account Category: Expenditures						
CAPITAL PROJECTS						
41-91000-58010	CAPITAL PROJECTS	550,000.00	68,874.65	2,732.50	481,125.35	12.52
41-91000-58030	CAPITAL EQUIPMENT	49,500.00	26,366.56	309.88	23,133.44	53.27
	CAPITAL PROJECTS	599,500.00	95,241.21	3,042.38	504,258.79	15.89
	Expenditures	599,500.00	95,241.21	3,042.38	504,258.79	15.89
Fund 41 - DEPARTMENT OF PUBLIC WORKS:						
	TOTAL REVENUES	130,000.00	166,381.63	(8,378.94)	(36,381.63)	
	TOTAL EXPENDITURES	599,500.00	95,241.21	3,042.38	504,258.79	
	NET OF REVENUES & EXPENDITURES:	(469,500.00)	71,140.42	(11,421.32)	(540,640.42)	
	BEG. FUND BALANCE	2,028,458.11	2,028,458.11			
	END FUND BALANCE	1,558,958.11	2,099,598.53			

REVENUE AND EXPENDITURE REPORT FOR VILLAGE OF BAYSIDE

Balance As of 08/31/2022

GL Number	Description	2022 Amended Budget	YTD Balance 08/31/2022	Activity For 08/31/2022	Available Balance 08/31/2022	% Bdgt Used
Fund: 42 ADMIN SERVICES CAPITAL						
Account Category: Revenues						
TAXES						
42-00000-41100	PROPERTY TAXES	75,000.00	75,000.00	0.00	0.00	100.00
	TAXES	75,000.00	75,000.00	0.00	0.00	100.00
INTERGOVERNMENTAL						
42-00000-43700	CDBG/ADA GRANT	0.00	7,957.50	0.00	(7,957.50)	100.00
	INTERGOVERNMENTAL	0.00	7,957.50	0.00	(7,957.50)	100.00
MISC REVENUE						
42-00000-48200	MISCELLANEOUS REVENUE	0.00	13,638.15	801.51	(13,638.15)	100.00
42-00000-48260	INSURANCE AWARDS/DIVIDENDS	0.00	1,333.00	0.00	(1,333.00)	100.00
	MISC REVENUE	0.00	14,971.15	801.51	(14,971.15)	100.00
	Revenues	75,000.00	97,928.65	801.51	(22,928.65)	130.57
Account Category: Expenditures						
CAPITAL PROJECTS						
42-91000-55190	GASB 45 OBLIGATIONS	86,689.00	24,939.98	24,939.98	61,749.02	28.77
42-91000-58010	CAPITAL PROJECTS	130,000.00	26,560.74	0.00	103,439.26	20.43
42-91000-58030	CAPITAL EQUIPMENT	61,500.00	60,838.69	0.00	661.31	98.92
	CAPITAL PROJECTS	278,189.00	112,339.41	24,939.98	165,849.59	40.38
	Expenditures	278,189.00	112,339.41	24,939.98	165,849.59	40.38
Fund 42 - ADMIN SERVICES CAPITAL:						
	TOTAL REVENUES	75,000.00	97,928.65	801.51	(22,928.65)	
	TOTAL EXPENDITURES	278,189.00	112,339.41	24,939.98	165,849.59	
	NET OF REVENUES & EXPENDITURES:	(203,189.00)	(14,410.76)	(24,138.47)	(188,778.24)	
	BEG. FUND BALANCE	682,226.81	682,226.81			
	END FUND BALANCE	479,037.81	667,816.05			

REVENUE AND EXPENDITURE REPORT FOR VILLAGE OF BAYSIDE

Balance As of 08/31/2022

GL Number	Description	2022 Amended Budget	YTD Balance 08/31/2022	Activity For 08/31/2022	Available Balance 08/31/2022	% Bdgt Used
Fund: 43 ARPA FUND						
Account Category: Revenues						
INTERGOVERNMENTAL						
43-00000-43700	ARPA GRANT FUNDS	226,817.00	0.00	0.00	226,817.00	0.00
	INTERGOVERNMENTAL	226,817.00	0.00	0.00	226,817.00	0.00
	Revenues	226,817.00	0.00	0.00	226,817.00	0.00
Fund 43 - ARPA FUND:						
	TOTAL REVENUES	226,817.00	0.00	0.00	226,817.00	
	TOTAL EXPENDITURES	0.00	0.00	0.00	0.00	
	NET OF REVENUES & EXPENDITURES:	226,817.00	0.00	0.00	226,817.00	
	BEG. FUND BALANCE	0.00	0.00			
	END FUND BALANCE	226,817.00	0.00			

REVENUE AND EXPENDITURE REPORT FOR VILLAGE OF BAYSIDE

Balance As of 08/31/2022

GL Number	Description	2022 Amended Budget	YTD Balance 08/31/2022	Activity For 08/31/2022	Available Balance 08/31/2022	% Bdgt Used
Fund: 46 PUBLIC SAFETY COMM CAPITAL						
Account Category: Revenues						
TAXES						
46-00000-41100	PROPERTY TAXES	22,395.00	22,395.00	0.00	0.00	100.00
	TAXES	22,395.00	22,395.00	0.00	0.00	100.00
INTERGOVERNMENTAL						
46-00000-47110	CONTRACT REVENUE	156,765.00	156,765.15	0.00	(0.15)	100.00
	INTERGOVERNMENTAL	156,765.00	156,765.15	0.00	(0.15)	100.00
	Revenues	179,160.00	179,160.15	0.00	(0.15)	100.00
Account Category: Expenditures						
CAPITAL PROJECTS						
46-91000-58010	CAPITAL PROJECTS	174,000.00	99,187.12	4,864.87	74,812.88	57.00
46-91000-58030	CAPITAL EQUIPMENT	301,000.00	107,577.05	0.00	193,422.95	35.74
	CAPITAL PROJECTS	475,000.00	206,764.17	4,864.87	268,235.83	43.53
	Expenditures	475,000.00	206,764.17	4,864.87	268,235.83	43.53
Fund 46 - PUBLIC SAFETY COMM CAPITAL:						
	TOTAL REVENUES	179,160.00	179,160.15	0.00	(0.15)	
	TOTAL EXPENDITURES	475,000.00	206,764.17	4,864.87	268,235.83	
	NET OF REVENUES & EXPENDITURES:	(295,840.00)	(27,604.02)	(4,864.87)	(268,235.98)	
	BEG. FUND BALANCE	703,219.40	703,219.40			
	END FUND BALANCE	407,379.40	675,615.38			

REVENUE AND EXPENDITURE REPORT FOR VILLAGE OF BAYSIDE

Balance As of 08/31/2022

GL Number	Description	2022 Amended Budget	YTD Balance 08/31/2022	Activity For 08/31/2022	Available Balance 08/31/2022	% Bdgt Used
Fund: 50 LIBRARY FUND						
Account Category: Revenues						
INTERGOVERNMENTAL						
50-00000-47400	JOINT LIBRARY RECEIVABLES	953,032.00	739,838.75	0.00	213,193.25	77.63
	INTERGOVERNMENTAL	953,032.00	739,838.75	0.00	213,193.25	77.63
MISC REVENUE						
50-00000-47410	LIBRARY COPY FEES	5,000.00	3,594.52	864.55	1,405.48	71.89
50-00000-47420	LIBRARY FINES	15,000.00	12,467.88	1,156.61	2,532.12	83.12
50-00000-47430	NET LENDER REVENUE	175.00	263.00	0.00	(88.00)	150.29
50-00000-47440	MISC REVENUE	0.00	1,975.25	0.00	(1,975.25)	100.00
50-00000-47450	LOST BOOK REVENUE	5,000.00	2,543.41	233.48	2,456.59	50.87
50-00000-48200	SUNDRY OTHER INCOME	500.00	(508.99)	0.00	1,008.99	(101.80)
	MISC REVENUE	25,675.00	20,335.07	2,254.64	5,339.93	79.20
	Revenues	978,707.00	760,173.82	2,254.64	218,533.18	77.67
Account Category: Expenditures						
NORTH SHORE LIBRARY						
50-61000-51100	LIBRARY DIRECTOR SALARY	351,994.58	81,534.41	8,279.56	270,460.17	23.16
50-61000-51120	SALARIES PT	253,271.42	209,452.11	21,909.98	43,819.31	82.70
50-61000-51170	HEALTH INSURANCE BUYOUT	2,000.00	0.00	0.00	2,000.00	0.00
50-61000-51190	DENTAL INSURANCE BUYOUT	272.00	0.00	0.00	272.00	0.00
50-61000-51200	SALARIES-OTHER LIBRARY STAFF	0.00	50,980.10	9,171.82	(50,980.10)	100.00
50-61000-51500	WISCONSIN RETIREMENT	24,801.00	11,054.38	1,507.38	13,746.62	44.57
50-61000-51510	SOCIAL SECURITY	47,211.00	22,035.70	2,935.26	25,175.30	46.67
50-61000-51520	LIFE INSURANCE	100.00	164.53	99.21	(64.53)	164.53
50-61000-51530	HEALTH INSURANCE	69,568.00	29,140.35	2,386.58	40,427.65	41.89
50-61000-51540	DENTAL INSURANCE	840.00	445.45	15.10	394.55	53.03
50-61000-51550	UNFUNDED LIABILITY-WRS	14,058.79	0.00	0.00	14,058.79	0.00
50-61000-52000	FACILITY MAINTENANCE & SUPPLIE	2,900.00	2,337.98	0.00	562.02	80.62
50-61000-52010	CLEANING & JANITORIAL SERVICES	28,800.00	13,392.62	0.00	15,407.38	46.50
50-61000-52020	HVAC MAINTENANCE	8,000.00	1,455.00	970.00	6,545.00	18.19
50-61000-52100	CONTRACTUAL SERVICES	35,060.00	11,522.13	1,408.09	23,537.87	32.86
50-61000-52110	LEGAL COUNCIL	2,500.00	0.00	0.00	2,500.00	0.00
50-61000-52200	UTILITIES	34,800.00	22,798.17	2,336.45	12,001.83	65.51
50-61000-52210	TELECOMMUNICATIONS	5,580.00	3,639.94	811.94	1,940.06	65.23
50-61000-52270	SYSTEM EXPENSE	44,450.00	35,727.09	0.00	8,722.91	80.38
50-61000-52290	BANKING FEES	100.00	110.73	0.00	(10.73)	110.73
50-61000-52300	MAINTENANCE	7,900.00	5,950.68	907.90	1,949.32	75.33
50-61000-52400	MISC COLLECTION MATERIALS	4,500.00	354.90	61.50	4,145.10	7.89
50-61000-52410	PERIODICALS	7,510.00	737.31	0.00	6,772.69	9.82
50-61000-52420	ADULT BOOKS	26,500.00	14,266.95	2,393.02	12,233.05	53.84
50-61000-52430	JUVENILE BOOKS	18,000.00	12,103.47	1,621.39	5,896.53	67.24
50-61000-52440	DVD ADULT	6,500.00	2,475.70	231.90	4,024.30	38.09
50-61000-52450	DVD JUVENILE	3,500.00	604.34	155.76	2,895.66	17.27
50-61000-52460	LOST BOOKS REPLACEMENTS	5,000.00	2,328.59	133.26	2,671.41	46.57
50-61000-52470	ADULT PROGRAMMING	3,000.00	1,879.75	0.00	1,120.25	62.66
50-61000-52480	JUVENILE PROGRAMMING	6,000.00	903.84	81.62	5,096.16	15.06
50-61000-53100	SUPPLIES	10,900.00	4,118.44	123.52	6,781.56	37.78
50-61000-53110	POSTAGE	300.00	56.18	0.00	243.82	18.73
50-61000-53210	DUES-EDUCATIONAL	1,035.00	132.02	0.00	902.98	12.76

REVENUE AND EXPENDITURE REPORT FOR VILLAGE OF BAYSIDE

Balance As of 08/31/2022

GL Number	Description	2022 Amended Budget	YTD Balance 08/31/2022	Activity For 08/31/2022	Available Balance 08/31/2022	% Bdgt Used
Fund: 50 LIBRARY FUND						
Account Category: Expenditures						
NORTH SHORE LIBRARY						
50-61000-53220	STAFF TRAINING	4,710.00	3,379.44	1,749.28	1,330.56	71.75
50-61000-53230	PROMO & ADVERTISING	1,372.00	1,228.99	95.00	143.01	89.58
50-61000-53500	EQUIPMENT REPLACEMENT	2,000.00	585.00	0.00	1,415.00	29.25
50-61000-55010	SALES TAX EXPENSE	500.00	0.00	0.00	500.00	0.00
50-61000-55100	INSURANCE AND BONDING	6,543.15	143.79	0.00	6,399.36	2.20
50-61000-55130	WORKERS COMP INSURANCE	1,728.00	0.00	0.00	1,728.00	0.00
50-61000-55350	LEASE/CONDO FEES	32,802.00	13,707.00	2,304.00	19,095.00	41.79
50-61000-58110	REFERENCE-SERIALS	0.00	1,669.36	0.00	(1,669.36)	100.00
50-61000-58120	ADULT BOOKS	0.00	117.06	0.00	(117.06)	100.00
50-61000-58130	JUVENILE BOOKS	0.00	3,283.72	0.00	(3,283.72)	100.00
50-61000-58300	ADULT PROGRAMS	0.00	451.30	0.00	(451.30)	100.00
50-61000-58350	LOST BOOKS	0.00	43.05	0.00	(43.05)	100.00
50-61060-59000	TRANSFER OUT	0.00	196,000.00	0.00	(196,000.00)	100.00
NORTH SHORE LIBRARY		1,076,606.94	762,311.57	61,689.52	314,295.37	70.81
Expenditures		1,076,606.94	762,311.57	61,689.52	314,295.37	70.81
Fund 50 - LIBRARY FUND:						
TOTAL REVENUES		978,707.00	760,173.82	2,254.64	218,533.18	
TOTAL EXPENDITURES		1,076,606.94	762,311.57	61,689.52	314,295.37	
NET OF REVENUES & EXPENDITURES:		(97,899.94)	(2,137.75)	(59,434.88)	(95,762.19)	
BEG. FUND BALANCE		224,052.82	224,052.82			
END FUND BALANCE		126,152.88	221,915.07			

REVENUE AND EXPENDITURE REPORT FOR VILLAGE OF BAYSIDE

Balance As of 08/31/2022

GL Number	Description	2022 Amended Budget	YTD Balance 08/31/2022	Activity For 08/31/2022	Available Balance 08/31/2022	% Bdgt Used
Fund: 55 LIBRARY DONATION FUND						
Account Category: Expenditures						
NORTH SHORE LIBRARY						
55-61000-52420	FOL ADULT BOOKS	0.00	3,085.30	0.00	(3,085.30)	100.00
55-61000-52430	FOL JUVENILE BOOKS	0.00	400.38	0.00	(400.38)	100.00
55-61000-52490	FOL CIRCULATION	0.00	238.39	0.00	(238.39)	100.00
	NORTH SHORE LIBRARY	0.00	3,724.07	0.00	(3,724.07)	100.00
	Expenditures	0.00	3,724.07	0.00	(3,724.07)	100.00
Fund 55 - LIBRARY DONATION FUND:						
	TOTAL REVENUES	0.00	0.00	0.00	0.00	
	TOTAL EXPENDITURES	0.00	3,724.07	0.00	(3,724.07)	
	NET OF REVENUES & EXPENDITURES:	0.00	(3,724.07)	0.00	3,724.07	
	BEG. FUND BALANCE	(26,091.15)	(26,091.15)			
	END FUND BALANCE	(26,091.15)	(29,815.22)			

REVENUE AND EXPENDITURE REPORT FOR VILLAGE OF BAYSIDE

Balance As of 08/31/2022

GL Number	Description	2022 Amended Budget	YTD Balance 08/31/2022	Activity For 08/31/2022	Available Balance 08/31/2022	% Bdgt Used
Fund: 60 LIBRARY CAPITAL FUND						
Account Category: Revenues						
MISC REVENUE						
60-00000-47500	DONATIONS	4,000,000.00	206,020.00	2,550.00	3,793,980.00	5.15
	MISC REVENUE	4,000,000.00	206,020.00	2,550.00	3,793,980.00	5.15
	Revenues	4,000,000.00	206,020.00	2,550.00	3,793,980.00	5.15
Account Category: Expenditures						
CAPITAL PROJECTS						
60-91000-58010	CAPITAL PROJECTS	4,000,000.00	172,346.18	0.00	3,827,653.82	4.31
	CAPITAL PROJECTS	4,000,000.00	172,346.18	0.00	3,827,653.82	4.31
	Expenditures	4,000,000.00	172,346.18	0.00	3,827,653.82	4.31
Fund 60 - LIBRARY CAPITAL FUND:						
	TOTAL REVENUES	4,000,000.00	206,020.00	2,550.00	3,793,980.00	
	TOTAL EXPENDITURES	4,000,000.00	172,346.18	0.00	3,827,653.82	
	NET OF REVENUES & EXPENDITURES:	0.00	33,673.82	2,550.00	(33,673.82)	
	BEG. FUND BALANCE	154,631.00	154,631.00			
	END FUND BALANCE	154,631.00	188,304.82			
Report Totals:						
	TOTAL REVENUES - ALL FUNDS	15,410,398.00	10,344,496.94	715,921.54	5,065,901.06	
	TOTAL EXPENDITURES - ALL FUNDS	17,183,144.94	7,319,125.63	637,307.76	9,864,019.31	
	NET OF REVENUES & EXPENDITURES:	(1,772,746.94)	3,025,371.31	78,613.78	(4,798,118.25)	



Village of Bayside
9075 N Regent Road
Board of Trustees Meeting
August 11, 2022
Village Board Room, 6:00pm

**BOARD OF TRUSTEES
Minutes**

I. CALL TO ORDER AND ROLL CALL

President Walny called the meeting to order at 6:00pm.

ROLL CALL

President: Eido Walny
Trustees: Mike Barth
Darren Fisher
Elizabeth Levins
Dan Rosenfeld
Bob Rudman
Margaret Zitzer

Also Present: Village Manager Andy Pederson
Administrative Services Director Rachel A. Safstrom
Assistant to the Village Manager Leah Hofer
Deputy Clerk/Treasurer Madeline Moltzan
Village Attorney Chris Jaekels
Operations Superintendent Shane Albers
Police Chief Doug Larsson
Police Captain Thomas Liebenthal
Communications Center Director Liane Scharnott
Communications Center Deputy Director Mandy Majors
North Shore Fire Chief Robert Whitaker
North Shore Health Department Director Becky Rowland
Department of Public Works Municipal Technician Bryan Herbst

II. PLEDGE OF ALLEGIANCE

III. CITIZENS AND DELEGATIONS

Open to any citizen who wishes to speak on items not on the agenda. Please note there may be limited discussion on the information received, however, no action will be taken. Please state your name and address for the record.

IV. CONSENT AGENDA

Upon request of any Trustee, any item may be removed from the Consent Agenda for separate consideration.

A. Approval of:

1. Summary of Claims for July 21, 2022, through August 4, 2022, in the amount of \$195,277.60.
2. July 2022 Financial Statement.
3. Board of Trustees meeting minutes, July 21, 2022.
4. July 2022 Community Impact Report.
5. Resolution 22-16, A Resolution amending Resolution 22-09 revising the fee schedule as referenced by the Village of Bayside Municipal Code.
6. Acceptance of Transportation Alternatives Program (TAP) Grant in the amount of \$64,000.
7. Right-of-way License Agreement with 636 E Bay Point Road.

Motion by Trustee Barth, seconded by Trustee Zitzer, to approve: Summary of Claims for July 21, 2022, through August 4, 2022, in the amount of \$195,277.60; July 2022 Financial Statement; Board of Trustees meeting minutes, July 21, 2022; July 2022 Community Impact Report; Resolution 22-16, A Resolution amending Resolution 22-09 revising the fee schedule as referenced by the Village of Bayside Municipal Code; Acceptance of Transportation Alternatives Program (TAP) Grant in the amount of \$64,000; and Right-of-way License Agreement with 636 E Bay Point Road. Motion carried unanimously by roll call vote.

V. BUSINESS AGENDA

- A.** Discussion/action on Proclamation Honoring Chief Douglas Larsson for 48 Years of Law Enforcement Service.

President Walny presented the proclamation to Chief of Police Douglass Larsson highlighting his career in the Village of Bayside. The Village Board thanked Chief Larsson for his service.

- B.** Presentation of Wisconsin State Legislative Citation to Chief Douglas Larsson from Representative Deb Andraca.

Presentation by Deb Andraca, starting by thanking Chief Larsson for his service. She highlighted their close relationship and his value to the community.

- C.** Discussion/action on Proclamation Honoring Bryan Herbst for 34 Years of Service.

President Walny presented the proclamation to Bryan Herbst as the longest serving employee of the Village, highlighting his loyal career. In addition to snow plowing, and street maintenance, Mr. Herbst collected at least 50 million pounds of waste.

- D.** Presentation of Wisconsin State Legislative Citation to Bryan Herbst from Representative Deb Andraca.

Deb Andraca presented a citation to Bryan Herbst, thanking him for his years of service and highlighted how he has made the Village better place.

E. COMMITTEE AND COMMISSION REPORTS

1. Public Safety Committee

- a.** Presentation/discussion on Emergency Medical Dispatching (EMD).

Bayside Communications Center Director, Liane Scharnott, stated the Bayside Communications Center has been working in conjunction with the North Shore Fire Department to implement Emergency Medical Dispatching training. The Medical Priority Dispatch System (MPDS) is a

medically approved, unified system to dispatch appropriate aid to medical emergencies. Bayside Communication Center staff will provide a presentation with details and changes to the dispatching process as a result of implementing EMD. It is anticipated that the EMD program will go live on September 1, 2022.

- b. Discussion/action on July 2022 Communications Center Report.

Director Liane Scharnott stated the BCC Supervisors attended Quality Control training for Emergency Medical Dispatching to prepare for the call audits and statistics the Center will utilize to measure success with Emergency Medical Dispatching.

Motion by Trustee Barth, seconded by Trustee Rosenfeld to approve the July 2022 Communications Center Report. Motion carried unanimously.

- c. Discussion/action on July 2022 Police Department Report.

Police Chief Doug Larsson gave the Police Department Report. Officer Klawitter was promoted to the rank of Lieutenant. Officer Dills organized a pick-up basketball game for grade school kids; over a dozen students participated.

Motion by Trustee Barth, seconded by Trustee Rudman to approve the July 2022 Police Department Report. Motion carried unanimously.

2. Public Works Committee

- a. Discussion/action on July 2022 Department of Public Works Report.

Superintendent Shane Albers spoke on an extensive culvert repair that was made on Fairway Drive due to aging infrastructure which created a large sink hole. Mr. Albers also introduced the new DPW Municipal Technician Michael Wied.

Motion by Trustee Barth, seconded by Zitzer, to approve the July 2022 Department of Public Works Report. Motion carried unanimously.

- b. Discussion/action on contract with All-Ways Contractors for the 2022 Tennyson Drive Storm Sewer project.

Manager Pederson stated that two bids were received from contractors to complete the Tennyson Drive Storm Sewer project. The low bidder was All-Ways Contractors, Inc. from Elm Grove, WI with a base bid of \$573,884. The engineering estimate was \$807,315. The low bid is 29% below the engineering estimate. The bids came in below the engineer estimate and the two bids were within 10% with no major discrepancies, indicating a competitive bid. Clark Dietz has had previous experience with All-Ways Contractors, Inc. and they have demonstrated adequate experience with comparably sized work. The proposed project would be funded through an American Rescue Plan Act grant in amount of \$453,633.52. The remaining funding would come from the 2021 storm water utility borrowing in the amount of \$120,250.48.

Motion by Trustee Barth, seconded by Trustee Zitzer, to approve the contract with All-Ways Contractors for the 2022 Tennyson Drive Storm Sewer project. Motion carried unanimously.

- c. Discussion/update on 2022 Capital Projects.

Manager Pederson provided a status overview of the 2022 Capital Projects.

2022 Stormwater and Road Project: The crew began marking and cutting driveway and cross culverts the week of July 11. Ditching and driveway culvert work began the week of July 18. The crew removed driveway approaches and built ramps for residents the week of July 25. The Ellsworth Lane area work was completed the week of August 1, where the crew will then move onto Pelham Parkway. Repaving is tentatively scheduled for the first week in October. As always, work is weather dependent.

Sanitary Sewer Lining: Lining work is anticipated to begin in later summer or early fall and manhole rehabilitation is anticipated to begin later fall or early winter. There are approximately 10,000 feet of main line and approximately 60 manholes.

Village Hall Board Room Technology Upgrades: The technology has been installed and virtual public meetings have begun with the soft launch of the process being the July 11 Architectural Review Committee meeting. Due to supply chain issues, the Village is still awaiting four microphones and the stand for the audience microphone.

Tennyson Stormwater Management Infrastructure Project: Final engineering plans are being developed. Based on engineering surveying, it appears a lift station will no longer be needed, and the drainage can occur via gravity. The bid opening was held, and a recommendation has been provided to the Board of Trustees.

East Bayside Sanitary Sewer Relief System: The Board of Trustees approved the design and construction services proposal at the June 23 Board of Trustees meeting. The scope of work includes extending the relief sewer to the intersection of Fairy Chasm Road and Tennyson drive to address persistent sewer capacity issues in the area.

Brown Deer Road Sanitary Sewer Infrastructure Study: The Board of Trustees approved the workplan at the June 23 Board of Trustees meeting. The workplan includes identifying sewer capacity restrictions and developing engineered solutions to address the restrictions in the 8-block area bound by Brown Deer Road, Krause Place, Iroquois Road, and Navajo Road. The scope of work includes creating a computer model of the sewers in the area.

Public Right-of-way Tree Removal: The Village has contracted Wallace Tree and Landscape, Inc. to remove an additional 108 trees within public right-of-way that have a yellow ribbon around them. The work is expected to begin in August.

3. North Shore Health Department

- a. Introduction of North Shore Health Department Director Becky Rowland.

Manager Pederson formally introduced North Shore Health Department Director Becky Rowland. Director Rowland then gave a brief description of her background.

4. North Shore Fire Department

- a. Presentation/update on the North Shore Fire Department-Glendale Station/Health Department project.

Chief Whitaker stated the North Shore Fire Department Glendale station has been scheduled to undergo significant renovation or rebuild. The Department has been engaged in a multi-year process to address facility needs.

At the same time, the North Shore Health Department has been seeking to consolidate its offices in Brown Deer and Shorewood into one location. Both agencies are currently working with architects for a potential movement of the health department/consolidation of office with the North Shore Fire Department.

- a. Discussion/action on July 2022 Administrative Services Report.

Rachel Safstrom briefly reviewed the Administrative Services Report. July was spent prepping for the August 9 Partisan Primary, where we had 46% turnout. Board of Review met on July 19 and changed one assessment.

Motion by Trustee Zitzer, seconded by Trustee Rudman to approve the July 2022 Administrative Services Report. Motion carried unanimously.

- b. Discussion/update from Village Assessor Lori Sacco.

Village Assessor Lori Sacco gave the update on reassessment process. Though the process still included the mandatory two hours of viewing of the roll, the Open Book process continued with phone appointments to allow residents greater flexibility in speaking to an assessor.

Trustee Barth stated that over the phone appointments went well and residents had the same conversation they are used to and stressed the need to communicate to residents the tax increase is from the recent referendums and not the assessment change.

Trustee Levins commended the assessor on a fine job with the appointments but wanted to be able to see previous years information online. She stated that the search function is excellent.

5. Board of Zoning Appeals

- a. Discussion/action on the request for a special exception by Kathleen and Thomas Roozen for a fence at the property located at 9126 N Meadowlark Ln, contrary to Section 104-125(k).

Village Manager Andy Pederson stated that no action is necessary, the Board of Zoning Appeals tabled this issue for 45 days. There has been a meeting at the house, and the village is working aggressively on the situation. The homeowner has been very cooperative with both Captain Liebenthal and Director Becky Rowland.

6. Architectural Review Committee

- a. Discussion/update on update to Fence Code.

Village Manager Pederson and Trustee Barth opened discussion on the updating the fence code. The goals of the updates include limiting confusion, simplifying administration, and limiting the number of times BZA would hear cases. The code has been updated a few times in the last two decades, and that has led to an overly complicated fence code.

A survey of the neighboring and like communities was conducted by staff. Proposed changes would possibly include allowing for full enclosure of the back yard, without regard to percent of permitter, and standardize the percent of open fence. Discussion occurred on the distance to the property line a fence can be, height of the fence, and percent open. The Architectural Review Committee will develop a recommendation and forward it back to the Village Board for consideration.

7. Plan Commission

No report.

8. Library Board

- a. Discussion/action on July 2022 North Shore Library Report.

No report.

VI. VILLAGE PRESIDENT'S REPORT

Village President Walny reported that myBlue Night Out was a success, and that Steve Anderson has resigned as Village President of River Hills.

VII. VILLAGE MANAGER'S REPORT

- A. Confirm appointment of Thomas Liebenthal as Police Chief.

Village Manager Andy Pederson started by thanking the retiring Police Chief Doug Larsson and the retiring Department of Public Works Equipment Operator and Service Technician Bryan Herbst for their years of service. Manager Pederson stated that Captain Liebenthal and Chief Larsson have worked together over the past two months as part of the Village's succession plan. If confirmed, the Oath of Office would be held Monday.

Motion by Trustee Barth, seconded by Trustee Fisher. Motion carried unanimously.

VIII. VILLAGE ATTORNEY'S REPORT

No report

IX. MISCELLANEOUS BUSINESS BY THE TRUSTEES AS MAY PROPERLY BE BROUGHT BEFORE THE BOARD

Trustee Barth commented on the Shorewood and Brown Deer IT contracts.

Trustee Levins read prepared remarks, see attached. President Walny requested the record to reflect that Trustee Levins voted in favor of the committee assignments 4 months ago.

X. ADJOURNMENT

Motion by Trustee Fisher, seconded by Trustee Barth, to adjourn the meeting at 7:26 p.m. Motion carried unanimously.

Trustee Levins' Statement:

"Four months ago I was elected to this Board with the highest number of votes by far in a field of four. Since then I have been treated by many of you with disdain, especially Village President Eido Walny who has not spoken a word to me. Upon my election he removed me, without consultation, from the Architectural Review Commission, to which I was appointed by Sam Dickman in 2016 and reappointed annually since. I am more qualified by education and experience for the ARC than any of the current members, including the longtime chair, a substitute teacher, who during my tenure exhibited difficulty reading architectural drawings.

Trustee Barth who came in a distant second in the last election is on five committees, Trustee Zitzer, three committees, plus Library and Joint Review, which are not shown on our website. Most Trustees are on two or more committees. I was appointed to one committee, Department of Public Works, which meets infrequently. The friends and family of our Village President and Trustees, people who were never elected or vetted by anyone, dominate Village of Bayside decision and policy making committees. Some of these people are on two or more committees.

This is insulting to the residents of Bayside, the voters who elected us. It smacks of cronyism, and is undemocratic. We should have competent people, with actual skills and credentials on our committees. We need an architect on Architectural Review. We need a CPA on Finance. This Board is running the Village like a private country club. It is shameful."



Community Impact Report

August 2022

FISCAL INTEGRITY: Provide sound financial management and future financial stability.

Metric	2021 Total	2022 YTD	5 Year Average	Target	Status
Bond Rating	Aa	Aa	Aa	Aa	●
GFOA Budget	Yes	Yes	Yes	Yes	●
GFOA ACFR	Yes	Yes	Yes	Yes	●
Grant \$	\$434,644	\$951,586	\$334,424	\$300,000	●
Fund Balance	29%	30%	27.5%	30%	●

Metric	2021 Total	2022 YTD	5 Year Average	Target	Status
Property Status	130	79	126	120	●
ICMA CPM	Yes	No	Yes	Yes	●
Total Permits	328	473	571	400	●
WComp Mod	0.74	0.74	1.013	1.0	●

COMMUNITY COLLABORATION: Maintain equitable, diverse, and inclusive community partnerships.

Metric	2021 Total	2022 YTD	5 Year Average	Target	Status
Meetings/ Events	62	32	54	55	●
Ordinances	5	9	10	15	●
Resolutions	30	16	28	25	●
myBlue Contacts	219	62	N/A	N/A	●

Metric	2021 Total	2022 YTD	5 Year Average	Target	Status
Drop Off Days	718	697	521	800	●
Codes Enforced	251	161	N/A	N/A	●
Votes Cast	1,664	3,629	3,833	7,250	●
Elections	2	3	2.8	4	●

CONNECTED COMMUNICATION: Provide proactive, reliable, and transparent communications.

Metric	2021 Total	2022 YTD	5 Year Average	Target	Status
Buzz open rate	58%	68%	50%	65%	●
Website Visits	60,581	39,975	130,641	60,000	●
Social Media	420,598	180,874	303,407	450,000	●
Newsletter	12	8	12	12	●

Metric	2021 Total	2022 YTD	5 Year Average	Target	Status
SCF Requests	2,820	1,792	1,950	2,700	●
SCF DTA	0.5	0.1	1.22	1	●
SCF DTC	7.2	2.2	13.2	7	●
SCF SLA%	84%	94%	73.8%	90%	●

SERVICE EXCELLENCE: Provide solution-based innovative services.

Metric	2021 Total	2022 YTD	5 Year Average	Status
Dispatch Time	39 sec.	42 sec.	31.42 sec	●
Dispatch Calls	116,749	71,971	110,674	●
911 Calls	28,909	17,709	26,669	●
BCC Train Hrs.	1,818	2,953	1,675	●
Call Reviews	97.5%	98%	95%	●
Calls for Police	5,426	3,132	5,920	●
Police Accred.	Yes	Yes	Yes	●

Metric	2021 Total	2022 YTD	5 Year Average	Status
Police Calls	70,186	53,205	74,008*	●
Fire Calls	10,440	7,468	4,459**	●
ALS Calls	2,967	2,200	2,656**	●
Miles Patrolled	99,603	63,414	109,324	●
Traffic Stops	1,830	1,219	2,185	●
Citations	779	619	925	●

SUSTAINABLE RESILIENCE: Provide environmental stewardship and promote future resilience.

Metric	2021 Total	2022 YTD	5 Year Average	Target	Status
Garbage Tons	1,404	849	1,257	1,500	●
Recycling Tons	475	298	510	500	●
Yard Waste (yds)	4,517	1,162	3,233**	2,500	●
Special Pickups	175	88	158	165	●
Diversion Rate	25%	26%	29%	30%	●

Metric	2021 Total	2022 YTD	5 Year Average	Target	Status
Culvert Replaced	31	16	38	50	●
Rx Drugs (lbs)	492	370	496	450	●
Tree City USA	Yes	Yes	Yes	Yes	●
Sewer Cleaned	30,188	0	25,232	26,000	●
Bird City USA	Yes	Yes	Yes	Yes	●

* = per year data unavailable

**APPLICATION AND RIGHT OF PRIVILEGE
FOR TREE ADJACENT TO PRIVATE RESIDENCE**

Applicant: David Cohen

Address: 8580 N. Fielding Road
Bayside, WI 53217

Telephone: 414-899-5126 email: ravdbc@gmail.com

Application must be accompanied by a reasonably dimensioned, accurate, and legible map.

(A) Location of right-of-way subject to Privilege: see attached map as depicted in the attached Exhibit A ("**Privilege Area**").

(B) Reason for Privilege and Proposed Use: Maintenance of tree owned by Applicant.

(C) Nature of obstruction or excavation: Tree maintained in the Privilege Area as depicted in Exhibit B ("**Obstructions**").

(D) As consideration for the Village granting this Privilege, the Applicant will follow all applicable rules as outlined by Wisconsin State Statute 66.0425, including, but not limited to:

1. Applicant assumes primary liability for damage to persons or property resulting from this Privilege.
2. Applicant agrees to remove all Obstructions on ten (10) days notice from the Village or the State of Wisconsin.
3. Applicant waives the right to contest in any manner the validity of 66.0425 Wis. Stats. or the rent charged by the Village.
4. Applicant shall maintain comprehensive general liability insurance on the Privilege Area in an amount not less than Five Hundred Thousand Dollars (\$500,000.00).
5. All obstructions under this Privilege must be the subject of Village Board approval.

(E) As further consideration and additional rent for this Privilege, Applicant agrees to assume full responsibility for:

1. All short and long-term maintenance and restoration of Privilege Area:
 - Advance notice and Village approval of maintenance or restoration that obstructs right-of-way further unless under emergency conditions.

2. All property maintenance.
 - Removal of scrub growth and weeds as necessary
 - Lawn maintenance as necessary
 - Tree trimming as necessary

3. All safety (including traffic) and security measures as necessary.

Submitted and certified as to truth and accuracy:	
David B. Cohen 	8/9/2022
Applicant	Date
homeowner	
Title	
Accepted and Privilege granted.	
Village of Bayside	Date

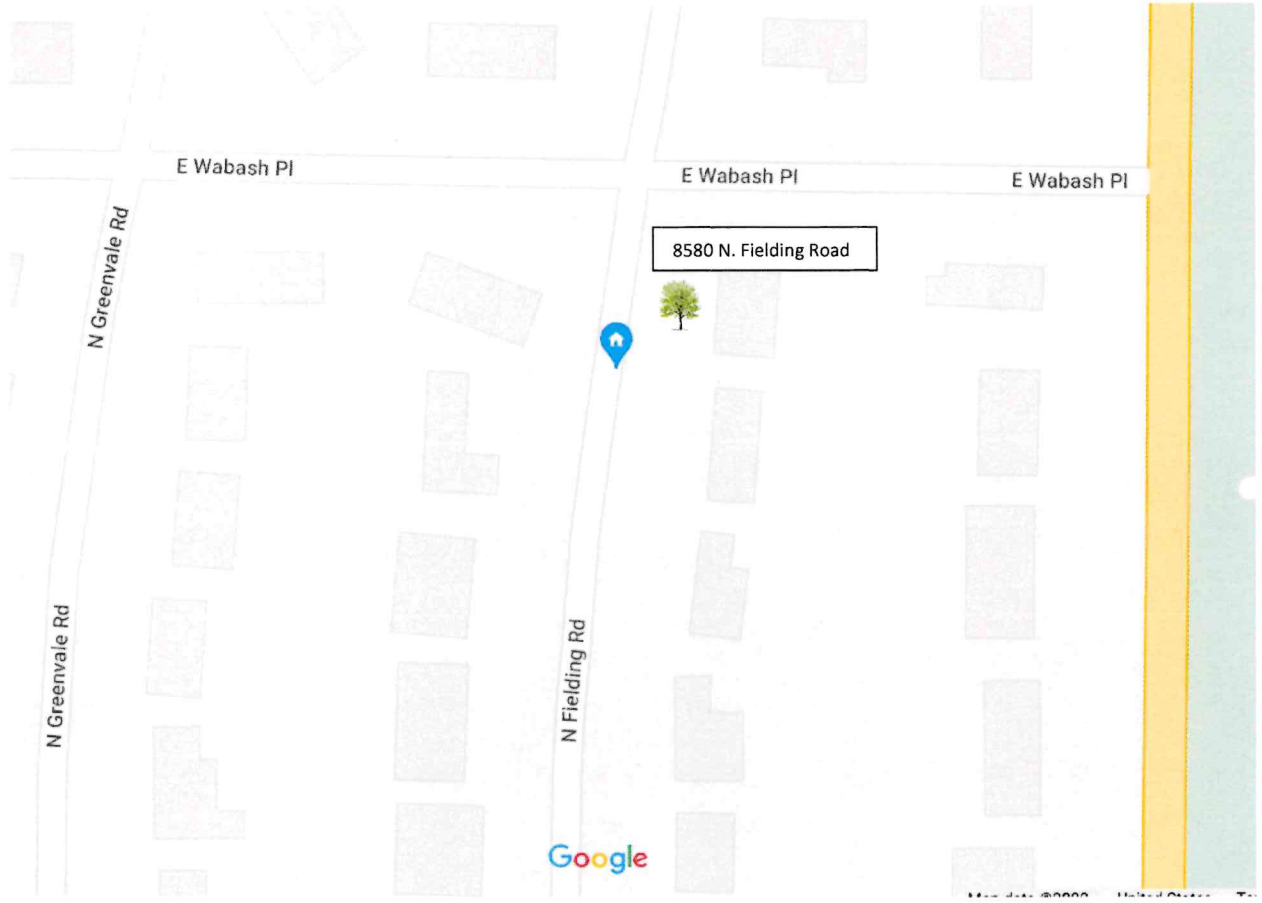

**VILLAGE OF BAYSIDE
MILWAUKEE COUNTY, WISCONSIN**

RAZE OR REPAIR ORDER

TO: David Roll & Barbara Paulsen
9121 N. Tennyson Drive
Bayside, WI 53217

RE: 9121 N. Tennyson Drive
Tax Key No. 020-0040-000

PLEASE TAKE NOTICE that the Village of Bayside Building Inspector has determined that portions of the structure located at 9121 N. Tennyson Drive, Village of Bayside, Wisconsin, also known by Tax Key No. 020-0040-000 is out of repair and consequently dangerous, unsafe, and otherwise unfit for use or occupation until necessary repairs have been made. The owner of this property has 30 days from service of this Order in which to repair or raze the structure. In order to satisfy this Raze or Repair Order, repairs to be made shall include the following:

- Repair to bring structure into compliance with Village and Building Code including, but not limited to,
 - roof structural support and roof replacement.
 - exterior soffit, fascia, and wood materials.
 - uninhabitable interior rooms and bathrooms.
 - Plumbing, HVAC and electrical systems.
- Maintain to bring exterior landscape into compliance with Village Code.

This Order is made pursuant to the provisions of Section 104-49 of the Bayside Municipal Code and Section 66.0413 Wis. Stats. The failure to comply with the terms of this Order shall result in the Village of Bayside seeking remedies available under the statutory section cited including the razing of the offending structure by Court Order.

Dated this _____ day of September, 2022.

Tod Doebler
Village of Bayside Building Inspector



Ewald Automotive Group

Scott Kussow | 262-567-5555 | skfleet@ewaldauto.com

Village of Bayside Police Department

Prepared For: Thomas Liebenthal

tliebenthal@baysidewi.gov

Vehicle: [Fleet] 2023 Ford Police Interceptor Utility (K8A) AWD





Ewald Automotive Group

Scott Kussow | 262-567-5555 | skfleet@ewaldauto.com

Vehicle: [Fleet] 2023 Ford Police Interceptor Utility (K8A) AWD (Complete)

Quote Worksheet

	MSRP
Base Price	\$47,165.00
Dest Charge	\$1,495.00
Total Options	\$5,215.00
Subtotal	\$53,875.00
Subtotal Pre-Tax Adjustments	
	\$0.00
Less Customer Discount	(\$8,612.00)
Subtotal Discount	(\$8,612.00)
Trade-In	\$0.00
Subtotal Trade-In	\$0.00
Taxable Price	
	\$45,263.00
Sales Tax	\$0.00
Subtotal Taxes	\$0.00
Subtotal Post-Tax Adjustments	
	\$0.00
Total Sales Price	
	\$45,263.00

Comments:

2023 Ford Interceptor Utility Hybrid to your specs as detailed, (similar to '22 order). Registration fees are not included. Delivery can not be anticipated due to current market conditions.

FINAL ORDER DATE 9/9/22!

State Contract # 505ENT-M21-VEHICLES-03.

Dealer Signature / Date

Customer Signature / Date

This document contains information considered Confidential between GM and its Clients uniquely. The information provided is not intended for public disclosure. Prices, specifications, and availability are subject to change without notice, and do not include certain fees, taxes and charges that may be required by law or vary by manufacturer or region. Performance figures are guidelines only, and actual performance may vary. Photos may not represent actual vehicles or exact configurations. Content based on report preparer's input is subject to the accuracy of the input provided.

Data Version: 17397. Data Updated: Sep 6, 2022 6:55:00 PM PDT.

Table 2 – 2023 Clean Sweep Grant Allocations

Prescription drug grants (Rx) are included so that you can see total funding for those of you with three grants (Ag/HHW/Rx.)

Agency, Gov., Tribe	Ag Allocation	HHW Allocation	Rx Allocation	Total
Adams County	\$4,695.00	\$8,000.00		\$12,695.00
Brown County	\$19,200.00	\$31,550.00		\$50,750.00
Buffalo County Recycling Responsible Unit	\$4,190.00	\$7,120.00		\$11,310.00
Calumet County		\$10,200.00		\$10,200.00
Chippewa Falls Police Department			\$5,400.00	\$5,400.00
City of Burlington		\$15,150.00		\$15,150.00
City of Fond du Lac		\$6,950.00		\$6,950.00
City of Menomonie		\$8,020.00		\$8,020.00
City of Racine Public Health Department			\$7,250.00	\$7,250.00
City of Sheboygan Falls			\$2,750.00	\$2,750.00
City of Sun Prairie Police Department			\$1,340.00	\$1,340.00
County of Crawford	\$2,900.00	\$5,000.00		\$7,900.00
Dane County	\$24,600.00	\$33,600.00		\$58,200.00
Dodge County	\$2,850.00	\$4,000.00		\$6,850.00
Eau Claire County		\$8,020.00		\$8,020.00
Green Lake County Land Conservation	\$4,690.00	\$8,020.00		\$12,710.00
Jefferson County Solid Waste	\$6,600.00	\$10,250.00	\$3,650.00	\$20,500.00
Juneau County Land & Water Resources	\$4,690.00	\$8,020.00		\$12,710.00
Kewaunee County	\$4,790.00	\$8,150.00	\$3,500.00	\$16,440.00
La Crosse County Household Hazardous Materials Program	\$6,600.00	\$10,750.00	\$4,550.00	\$21,900.00
Manitowoc County	\$18,000.00	\$30,550.00	\$7,250.00	\$55,800.00
Marathon County Solid Waste Department	\$6,600.00	\$10,660.00		\$17,260.00
Marquette County	\$4,790.00	\$8,130.00		\$12,920.00
Milwaukee Metropolitan Sewerage District		\$10,600.00		\$10,600.00
Monroe County Sheriff's Office			\$2,210.00	\$2,210.00

Monroe County Solid Waste	\$1,000.00	\$6,200.00		\$7,200.00
Northwest Regional Planning Commission	\$24,550.00	\$33,600.00	\$3,600.00	\$61,750.00
Oconto County Health and Human Services-Public Health Division			\$4,500.00	\$4,500.00
Oneida County Solid Waste	\$6,450.00	\$10,550.00	\$3,500.00	\$20,500.00
Oneida Nation		\$10,050.00		\$10,050.00
Ozaukee County Land & Water Management Department	\$4,790.00	\$8,130.00		\$12,920.00
Polk County	\$5,990.00	\$10,160.00		\$16,150.00
Portage County		\$9,165.00		\$9,165.00
Racine Wastewater Utility		\$33,500.00		\$33,500.00
Rock County Land Conservation Department	\$1,250.00	\$5,175.00		\$6,425.00
Rock County Public Health Department			\$5,450.00	\$5,450.00
Sauk County Land Resources and Environment Department	\$3,600.00	\$8,130.00		\$11,730.00
St Francis Police Department			\$700.00	\$700.00
St. Croix County	\$6,600.00	\$10,150.00		\$16,750.00
UW Extension-Green County	\$2,400.00	\$5,840.00		\$8,240.00
Vernon County	\$4,690.00	\$8,000.00		\$12,690.00
Village of Bayside		\$6,000.00	\$3,100.00	\$9,100.00
Village of Coflax		\$8,120.00		\$8,120.00
Village of McFarland Police Department			\$950.00	\$950.00
Village of Pleasant Prairie		\$10,660.00		\$10,660.00
Walworth County Public Works	\$4,820.00	\$10,210.00	\$4,500.00	\$19,530.00
Washington County Natural Resources	\$1,300.00	\$10,300.00		\$11,600.00
Washington Ozaukee Public Health Department			\$5,000.00	\$5,000.00
Waukesha County	\$6,600.00	\$10,750.00		\$17,350.00
Waunakee Police Department			\$1,750.00	\$1,750.00
Waupaca County	\$5,980.00	\$9,450.00	\$4,050.00	\$19,480.00

**STATE OF WISCONSIN
MILWAUKEE AND OZAUKEE COUNTIES VILLAGE
OF BAYSIDE**

RESOLUTION NO: 22-

A Resolution to Amend the 2022 Annual Program Budget

WHEREAS, Resolution 21-35, a resolution adopting the 2022 Annual Program Budget and establishing the 2021 tax levy, was adopted on November 18, 2021; and

WHEREAS, Fuel expenses have increased significantly since the adoption of the 2022 Annual Program Budget; and

WHEREAS, Building Inspection Permits have increased significantly causing an increase in inspection fees; and

WHEREAS, Stormwater and Sewer Projects have been identified requiring engineering services which were not budgeted; and

WHEREAS, with the approval of the Stormwater project at Tennyson Dr., the ARPA Funds would be reallocated to the Stormwater Fund to offset the project costs; and

WHEREAS, the Verizon and AT&T cell tower agreement funds had not been allocated in the 2022 budget; and

NOW, THEREFORE, BE IT RESOLVED, BY THE BOARD OF TRUSTEES, that it hereby amends the 2022 Annual Program Budget as follows:

Account Name	Account Number	Budgeted Amount	Amended Budget	Increase/Decrease
Sanitary Sewer Engineering	20-51000-52160	\$50,000	\$127,577	\$77,577
Sewer Capital Projects	20-51000-58010	\$342,500	\$334,923	(\$75,577)
Stormwater Engineering	22-53000-52160	\$40,000	\$106,000	\$66,000
Stormwater Fund Balance	22-00000-34000	\$1,862,859	\$301,000	(\$66,000)
Stormwater Equipment Replacement	22-53000-53500	\$0	\$48,000	\$48,000
ARPA Fund	43-51000-58030	\$453,634	0	(\$453,634)
Stormwater Capital Projects	22-53000-58010	\$380,000	\$833,634	\$453,634
Police Capital – Cell Phone Reimbursement	40-00000-44350	\$0	\$48,500	\$48,500

General Fund				
Account Name	Account Number	Budgeted Amount	Amended Budget	Increase/Decrease
Public Works Fuel	10-53000-53400	\$20,000	\$38,000	\$18,000
Building Inspection	10-524000-52500	\$35,750	\$91,750	\$56,000
Village Hall Equipment Replacement	10-51000-53500	\$58,026	\$262,970	(\$58,026)

PASSED AND ADOPTED by the Village Board of the Village of Bayside this twenty-second day of September, 2022.

VILLAGE OF BAYSIDE

Eido M. Walny, Village President

Rachel A. Safstrom
Administrative Services Director

**STATE OF WISCONSIN
MILWAUKEE AND OZAUKEE COUNTIES
VILLAGE OF BAYSIDE**

RESOLUTION NO: 22-___

**A Resolution Authorizing the Village of Bayside to file
the Urban Forestry Grant Application**

WHEREAS, the Village of Bayside is interested in obtaining a cost-share grant from Wisconsin Department of Natural Resources for the purpose of funding urban and community forestry projects or urban forestry catastrophic storm projects specified in s. 23.097(1g) and (1r), Wis. Stats.; and

WHEREAS, the applicant attests to the validity and veracity of the statements and representations contained in the grant application; and

WHEREAS, the applicant requests a grant agreement to carry out the project;

THEREFORE, BE IT RESOLVED, the Village of Bayside will comply with all local, state, and federal rules, regulations and ordinances relating to this project and the cost-share agreement;

BE IT FURTHER RESOLVED, the Village of Bayside will budget a sum sufficient to fully and satisfactorily complete the project and hereby authorizes and empowers the Village Manager, its employee, to act on its behalf to:

1. Sign and submit the grant application
2. Sign a grant agreement between applicant and the DNR
3. Submit interim and/or final reports to the DNR to satisfy the grant agreement
4. Submit grant reimbursement request to the DNR
5. Sign and submit other required documentation

PASSED AND ADOPTED by the Village Board of Trustees of the Village of Bayside this twenty-second day of September, 2022.

VILLAGE OF BAYSIDE

Eido M. Walny, Village President

Rachel A. Safstrom, Administrative Services
Director

**STATE OF WISCONSIN
MILWAUKEE AND OZAUKEE COUNTIES
VILLAGE OF BAYSIDE**

A Proclamation Recognizing the Retirement of Police Chief Douglas Larsson after 48 Years of Law Enforcement Service.

WHEREAS, Chief Larsson is retiring from service with the Village on August 12, 2022, and has nobly and faithfully served as Police Chief with the Village of Bayside for over 4.5 years and dedicated 48 years to service in public safety; and

WHEREAS, Chief Larsson transformed the Bayside Police Department, hiring a majority of the staff serving the Bayside Police Department today and promoting numerous officers to enhanced responsibility and leadership roles within the Department; and

WHEREAS, Chief Larsson developed sound succession plans for future police leadership here at the Village; and

WHEREAS, Chief Larsson encouraged innovation and initiative within the Police Department and throughout the Village; and

WHEREAS, Chief Larsson is dedicated to the ideals of community policing, community engagement, evidenced by creation of the myBlue program and myBlue night out; and

WHEREAS, Chief Larsson adapted quickly and without hesitation during the unprecedented time of the COVID-19 pandemic and changes in policing; and

WHEREAS, Chief Larsson demonstrated patience, fairness, and a people first leadership style during his time at the Village and throughout his career; and

WHEREAS, Chief Larsson has left an everlasting legacy within the Village of Bayside, its Police Department, and all of the agencies he has served;

THEREFORE, BE IT RESOLVED, that, Eido Walny, Village President and the Village Board of Trustees wishes to express their deep appreciation to Douglas Larsson for his 48 years of law enforcement services and wishes him all the best in his retirement.

PASSED AND ADOPTED by the Village Board of Trustees of the Village of Bayside this eleventh day of August 2022.

VILLAGE OF BAYSIDE

Eido M. Walny, Village President

Rachel A. Safstrom, Administrative Services Director

**STATE OF WISCONSIN
MILWAUKEE AND OZAUKEE COUNTIES
VILLAGE OF BAYSIDE**

**A Proclamation Recognizing the Retirement of Department of Public Works Municipal Technician,
Bryan Herbst, after 34 Years of Service to the Village.**

WHEREAS, Bryan Herbst started his employment with the Village on August 22, 1988 and is retiring from service with the Village on September 9, 2022; and

WHEREAS, Bryan is the longest current serving employee for the Village and was dedicated to the Village and committed to his work, enduring all working conditions with a smile, whether it was rain, flooding, sleet, snow, blizzard, or sunshine; and

WHEREAS, Bryan left a positive impression on everyone he encountered with his witty humor and will be remembered for the genuine care he showed everyone he served or encountered as well as the community as whole; and

WHEREAS, Bryan was a hero to so many residents, young and old alike, that waited daily for him to pass by, wave, say “hi”, and even pass out miniature toy garbage trucks to his fans, and conducting a “Trash Bash” birthday party for 3-year old Beckett Wahl in the garbage truck;

WHEREAS, Bryan with his witty sense of humor and personality, named his pride and joy, the former automated garbage truck, Marleta, and the current garbage truck, Rhonda;

WHEREAS, Bryan collected an estimated 50,000,000 to 75,000,000 pounds of garbage, recycling, and yard waste over his 34 years and conducted millions of stops at residents’ homes collecting the Village’s garbage, recycling, and yard waste; an

WHEREAS, Bryan Herbst’s personality, friendship, historical knowledge of the Village will be dearly missed; and

THEREFORE, BE IT RESOLVED, that, Eido M. Walny, Village President and the Village Board of Trustees wishes to express their deep appreciation to Bryan Herbst for his 34 years of service to the Village and wishes him all the best in his retirement.

PASSED AND ADOPTED by the Village Board of Trustees of the Village of Bayside this eleventh day of August 2022.

VILLAGE OF BAYSIDE

Eido M. Walny, Village President

Rachel A. Safstrom, Administrative Services Director

Wisconsin Participation Agreement

WHEREAS, under Wis. Stats. § 256.35 (3s), the State of Wisconsin Department of Military Affairs (“State”), as advised by the 9-1-1 Subcommittee, is providing the network necessary for Public Safety Answering Points (“PSAP”) to implement and upgrade to NextGen9-1-1 services; and

WHEREAS, AT&T Corp. (“AT&T”) and the State are parties to Contract Number 465OEC-ESIMAJ0619-00, dated June 29, 2021 (the “Contract”) for the Statewide Emergency Service Internet Protocol Network (AT&T ESInet™), Next Generation Core Services (NGCS) based on NENA i3 standards, and ECaTS reporting project as detailed in the State’s Request for Proposal # MAJ0619 and the Contractor’s response thereto (“Services”). All of these Services combined are referred to as System as a Service (SYSaaS); and

WHEREAS, _____ (“Participant”) operates a PSAP or an Emergency Communications Center (“ECC”) authorized and operating under the laws of the State of Wisconsin; and

WHEREAS, Participant wishes to obtain the SYSaaS provided by AT&T under the Contract.

NOW, THEREFORE, FOR GOOD AND VALUABLE CONSIDERATION, INCLUDING THE PROMISES SET FORTH BELOW, THE ACCEPTANCE OF WHICH IS HEREBY ACKNOWLEDGED AND ACCEPTED, AND IN LIGHT OF THE PREMISES SET FORTH ABOVE, PARTICIPANT, STATE, AND AT&T AGREE AS FOLLOWS:

1. This Participation Agreement, which includes Attachment 1 and the attached addendums, incorporated by reference, is made between the State, Participant, and AT&T (collectively, the “Parties”), and is effective on the date when first signed by all Parties subject to funding availability as determined by the State.
2. The implementation of this Participation Agreement may be delayed if the State determines funding is unavailable.
3. Participant agrees to join the SYSaaS established by the Contract. All Parties shall agree to items set forth in the Party Obligations Document attached hereto as Attachment 1. The Participant will not use the SYSaaS and/or equipment except as otherwise specified herein. The Participant agrees to only use the provided SYSaaS equipment in support of its role as a PSAP.
4. The SYSaaS monthly recurring charges for the Services for each Participant are paid for by the State under the Contract. Site remediation necessary to meet the minimum requirements to join the SYSaaS or for any services outside the scope of the Contract will be the responsibility of the Participant and is outside the scope of this Participation Agreement. To the extent that Participant desires services outside of the scope of the Contract, AT&T and Participant will enter into a separate agreement. The integration of a Participant’s Call Handling solution (including associated Call Handling customer premise equipment configurations and cabling), are outside the scope of the SYSaaS. This applies to Call Handling customer premise equipment which is managed by AT&T or some other provider.
5. Equipment, components and software installed on behalf of the State at the Participant’s location will remain the property of AT&T. Should the Contract between the State and AT&T terminate at any time for any reason, all equipment, installed on behalf of the State at the Participant’s location will have to be returned by the Participant to a location designated by



AT&T following the transition to an alternate service that ensures the continuity of 9-1-1 services. The Participant agrees to reasonably cooperate and facilitate the return of any and all equipment, on behalf of the State at the Participant’s location as may be required.

6. Under this Participation Agreement, all orders for the SYSaaS must be entered no later than August 7, 2029. Services obtained under this Participation Agreement will terminate on or before August 7, 2031. The State may terminate this Participation Agreement upon the termination, cancellation, expiration or amendment of the Contract. The Participant may terminate for convenience prior to acceptance of the site survey or after 36 months from going live on the SYSaaS. The Participant may terminate for cause upon written notice to AT&T and the State that AT&T has failed to perform under the Participation Agreement and AT&T fails or is unable to cure that failure within 30 days of the notice.
7. This Participation Agreement may not be assigned by Participant. Any such assignment shall be null and void.
8. The State shall be the last party to sign the Participation Agreement and shall provide a copy of the fully executed Participation Agreement and any attachments, exhibits, or appendices to all Parties within 30 business days of signature.
9. Any required notices under this Participation Agreement shall be in writing and shall be sent to the office of the recipient with a copy to the State as set forth below or to such other office or recipient as designated in writing from time to time:

To Participant:	To AT&T:	To State:
Name: _____	Name: <u>Paul Rzeznik</u>	Name: <u>Jessica Jimenez</u>
Title: _____	Title: <u>Public Safety Specialist</u>	Title: <u>NextGen911 Program Manager</u>
Address: _____	Address: <u>pr6251@att.com</u>	Email: <u>interop@wisconsin.gov</u>

10. This Participation Agreement constitutes the entire agreement between and among the Parties regarding its subject matter, except to the extent this Participation Agreement conflicts with the respective obligations and rights of AT&T and the State under the Contract, in which case, the provisions of the Contract shall control as between AT&T and the State.

This Participation Agreement shall not be modified or supplemented unless such modification or supplementation is agreed to in writing by all Parties.

11. AT&T and the State shall not be liable for any cybersecurity incidents that occur on the Participant’s side of demarcation point for Participant’s PSAP installation. Participant shall not be liable for any cybersecurity incidents propagated by the SYSaaS that occur beyond the Participant’s side of demarcation point.
12. If (a) Participant chooses to conduct a background check as part of conducting a background and/or criminal history investigation pursuant to Section 23.5 of the Contract General Terms and Conditions; and (b) Participant or its designee(s) obtains information regarding AT&T employees or subcontractors, which includes, but is not limited to, name, address, telephone number, driver’s license number, date of birth, health information, biometric data, social security number,



and other personal information obtained in connection with the investigation (collectively, “Sensitive Personal Information” or “SPI”), then:

- 12.1. Participant and its designee(s) shall consider the SPI to be private, sensitive and confidential.
- 12.2. Participant acknowledges that SPI may be subject to certain privacy laws and regulations and requirements and requires a high degree of protection.
- 12.3. Participant shall only utilize the information for the authorized purposes above, and shall comply with all applicable privacy laws and regulations and must treat such SPI with the same degree of care as Participant would treat SPI of its own employees and subcontractors including, without limitation:
 - 12.3.1. Collect SPI only as needed for a background and/or criminal history investigation;
 - 12.3.2. Not use, disclose, or distribute any SPI except in connection with a background and/or criminal history investigation;
 - 12.3.3. Store and transmit SPI securely, including without limitation encrypting SPI when it is at rest and being transmitted;
 - 12.3.4. Restrict access to SPI only to those employees of Participant or its designee(s) that require access to perform the services under this Participation Agreement or the Contract;
 - 12.3.5. Implement any reasonable administrative, physical, and technical safeguards to ensure proper use, and protect against any unauthorized disclosure, of SPI. If Participant becomes aware of an unauthorized disclosure of SPI, notify AT&T within 10 business days and cooperate with AT&T on any corrective actions needed.
13. Participant shall hold the State harmless and shall defend and indemnify the State, its Agencies, officers and employees against any and all claims, suits, actions, liabilities and costs of any kind, including attorney's fees, for personal injury or damage to property arising from the negligent, intentional or willful acts or omissions of the Participant, its agents, officers, employees or Subcontractors in performance of their obligations under this Participation Agreement to the extent to which those acts were done in the scope of their employment. Participant will be responsible for any charges incurred on Participant's side of the demarcation. The demarcation point is the edge router placed on the Participant's premises or such other location as may be agreed upon by the Participant and AT&T.
14. Except as already set forth herein, ownership of all records related to specific requests for emergency services (9-1-1 calls) or information within the Wisconsin SYSaaS are and shall remain the property of the Participant creating the record. All public records requests made to the State for such materials shall be referred to the Participant who created the record. The State will have access to aggregate data and reports regarding overall system use and individual Participant use. Such aggregate information will be the property of the State and subject to the open records laws.



15. Public Records Law. Section 19.36 of the Wisconsin Statutes, subject to § 19.36(5), requires the State and Participant to make records produced or collected by AT&T under this Participation Agreement and the Contract (collectively “Records”) available upon request for inspection and copying by any requestor as provided in Wis. Stat. § 19.35. The Parties recognize that some Records may contain trade secrets and that, pursuant to § 19.36(5), the State and/or participant may withhold or redact documents containing such information. If the State or Participant notifies AT&T of its intent to provide Records that may contain AT&T’s trade secrets, AT&T shall have five (5) business days to request a consultation with the State and/or Participation regarding the release of such Records. The State and/or Participant will consult with AT&T to the extent able to do so and still timely respond to the request for the Records. The State and/or Participant will withhold Records and redact information from Records as requested by AT&T only as permitted by statute, including, without limitation, Wis. Stat. § 19.36, or the common law.
16. Insurance. AT&T will cover the participating PSAPs with the same insurance limits and coverages as provided to the State under Section 14 of the Contract.
17. This Participation Agreement shall be governed by, construed, interpreted, and enforced in accordance with the laws of the State of Wisconsin. The Parties agree that for any claim or suit or other dispute relating to this Participation Agreement that cannot be mutually resolved, jurisdiction and venue shall be in _____ County, Wisconsin, for matters arising under state law or, should federal courts have jurisdiction, the _____ district of Wisconsin. The Parties agree to submit themselves to the jurisdiction of said courts, to the exclusion of any other court that may have jurisdiction over such a dispute according to any other law.
18. Each signatory below represents that he or she is authorized to sign this Participation Agreement on behalf of the party designated.

IN WITNESS WHEREOF, the State, AT&T, and Participant have caused this Participation Agreement to be executed by their duly authorized representatives as of the date written below.



Participant (PSAP)

By: _____
(by its authorized representatives)

(Typed or Printed Name & Title)

(Agency Name)

(Date)

**State of Wisconsin
Department of Military Affairs**

By: _____
(by its authorized representatives)

Erik Viel
(Typed or Printed Name)

Director of Emergency Communications
(Title)

(Date)

AT&T Corp.

By: _____
(by its authorized representatives)

Paul Rzeknik
(Typed or Printed Name)

Public Safety Specialist
(Title)

(Date)



ATTACHMENT 1: Party Obligations

The items listed below outline specific obligations under the Contract Number 465OEC-ESIMAJ0619-00 and the Wisconsin Participation Agreement that fall to the Participant (PSAP), AT&T Corp., and the State (DMA) to ensure a successful implementation of the SYSaaS.

PSAP Implementation Phase:

Participant Responsibilities –

- Appoint a Participant Project Manager to interface directly with the AT&T Project Manager.
- Designate a Geographic Information Systems (GIS) point of contact for data preparation and submissions.
- Supply required data via the PSAP Data Collection Template and the PSAP Site Survey Template in the timeframes outlined in the Project Plan. Additional details to be found in the Initial Discovery Survey document.
- Participate in status meetings regarding the project and approve mutually agreed to Project Plan.
- Ensure Call Processing Equipment (CPE)/Call Handling Equipment (CHE) provider is available at appropriate project team meetings and for testing. Coordinate any necessary compatibility testing directly with the AT&T Project Manager, if needed.
- Work with CPE/CHE provider to ensure costs for CPE/CHE connections are understood by the Participant.
- Participant shall ensure CPE at Participant site(s) interface with the SYSaaS via the supported NENA i3 interfaces.
- Connect any CAMA trunks and all relevant CPE/CHE connections including ANI/ALI controller (CPE/CHE) ports to the demarcation points of the PSAP Equipment, where applicable.
- Network edge equipment is the AT&T ESInet™ Network Termination Equipment (NTE). Participant shall ensure all NTE is located within one (1) equipment closet (MDF/IDF) per PSAP/Host site. The demarcation point is the edge router placed on the Participant's premises or such other location as may be agreed upon by the Participant and AT&T.
- Participant understands the potential costs associated with joining the SYSaaS and agrees to make any necessary and reasonable modifications needed, and maintain those modifications, including suitable space, power, ground, security, and environmental controls.
 - Costs covered by the Participant include:
 - Service connection at the Participant's side of the demarcation and any necessary site remediation (e.g., Call handling equipment connection, electrical work, backroom setup, SIP licensing, etc.)
 - Participants may incur additional monthly recurring charges if the final deployment configuration requires multiple locations
 - ECaTs Staffing Forecast Module – value add service
 - Report customization of ECaTS – value add service

AT&T Responsibilities –



- Assign a designated AT&T Project Manager to interface directly with the Participant during implementation.
- Conduct a project kick off call.
- Provide a project team contact list along with appropriate escalation paths. AT&T will provide updated contact information for any personnel changes within thirty (30) days of the change.
- Complete a mutually agreed upon project plan and timeline and obtain Participant approval.
- Conduct status meetings regarding the project.
- Provide site requirements and a site drawing for Participant review. AT&T may provide compatibility testing with a variety of vendors' equipment. Compatibility testing needs to be coordinated directly with the AT&T Project Manager, if needed.
- Conduct a site survey. Additional details to be found in the Initial Discovery Survey document.
- Coordinate the onsite installation of AT&T provided equipment/circuits including transport connections and test and turn up at the Participant Sites. All NTE is to be located within one (1) equipment closet (MDF/IDF) per PSAP/Host site.
- Installation services provided at the network edge are to be conducted during standard business hours (Mon-Fri 8 am-5 pm local).
- Coordinate with Participant for cut over and redirect of call traffic.
- Conduct Participant training.
- Provide supporting documentation on trouble ticket system and escalation procedures.
- As part of the project plan, AT&T Project Management will schedule an overview of the service and processes to use to request support.
- Review the acceptance test plan and coordinate execution of testing with Participant prior to cut-over.
- Participant Contact Information (AT&T Responsibility to Capture from Participant):
 - Survey Requestor – This is the contact information of the individual that has requested the site survey be performed.
 - Technical Site Contact – This individual will be consulted on all the technical aspects of the physical installation and any subsequent clarifications needed.
 - Site Survey Technical Contact – This is the contact information of technician assisting AT&T with the site survey. This information will be used to gather initial site information and subsequent clarifications.
 - Site Delivery Contact – This individual will be available to receive, and sign for, deliveries of equipment and supplies.
 - Management Site Contacts – Contact to authorize changes, to assist in escalations, and to provide necessary information throughout the life cycle of the service. Depending on the size of the PSAP, may require multiple management site contacts.
 - Information will contain the following data points:
 - Contact Name
 - Address 1
 - Address 2
 - City State, Zip Code
 - Work Phone
 - Mobile Phone
 - Email



State Responsibilities –

- Maintain awareness of planned and ongoing PSAP implementations and funding availability.
- Determine operational date for each county per Wis. Stats. § [256.35 \(3s\) \(c\)](#).
- Assist with issue escalation between AT&T and PSAP during service implementation.
- Education and outreach, as needed.

ALI Database, GIS, and Other Data Responsibilities:

Participant's Responsibilities –

- The Participant agrees to work with the State and AT&T to migrate their Automatic Location Identification (ALI) database from the current provider to the SYSaaS location database system (EGDMS), as well as maintain the Master Street Address Guide (MSAG) database for validation, until such time as the State develops a GIS derived MSAG.
- The Participant agrees to work with the State and AT&T regarding GIS data needs specific to implementing geospatial routing on the SYSaaS.
- The Participant will be provided training, assistance, and the systems needed to receive this data for the first time and on an on-going basis. The State may provide separate GIS data management services to the Participant and/or local GIS resource.
- The Participant and/or its local GIS resource agree to work with AT&T or other contractor to resolve identified GIS data issues as quickly as possible. In general, local GIS resources will not be required to change their local GIS data formats, at the time of this Agreement. AT&T will make all reasonable efforts to work with the local data's existing formats. However, in some cases, a local GIS resource may be asked to add, for example, an additional data field, such as a unique identifier, to help aid in support of the overall SYSaaS.

AT&T Responsibilities –

- AT&T will provide any assistance and training needed when such a change is requested.

All Parties' Responsibilities –

- All GIS data provided to the State or AT&T under this Agreement will only be used for public safety purposes, primarily within the SYSaaS. Any requests received by the State or AT&T for local data will be referred to the local source of data.

Originating Service Providers Migration Phase:

Participant Responsibilities –

- Provide AT&T a Letter of Authorization (LOA) to communicate/coordinate with OSPs.
- Provide all required notices to the appropriate government agencies regarding needed network changes.
- Work with AT&T to establish target timeframes for OSPs to move their trunks to the Point of Interconnection (POI) and communicate interface information to the OSPs.
- Assist in addressing OSP delay in moving trunks to AT&T ESInet POIs.

AT&T Responsibilities –



- Provide POIs, order information, and assist any build-out that is required.
- Advise the PSAP with any issues with the OSPs moving their trunks within the target timeframe.
- Notify OSPs that the Emergency Service Provider is changing to AT&T ESInet™.

State Responsibilities –

- Assist in identifying OSPs for connection.
- Provide 30-day written notification to applicable parties regarding the end of legacy E9-1-1 county contract and any charges previously authorized under Wis. Stats. § [256.35 \(3\) \(b\)](#).

Test and Turn-up of Service Phase:

Participant Responsibilities –

- This is the process where the service is tested and turned over to the Participant.
- AT&T will develop a test plan with the Participant.
- Participant will designate a coordinator for the test and turn-up process. If necessary, ensure the CPE vendor is accessible during the testing process.
- Participant has 14 days to let AT&T know if there are any issues that are within the scope of this project. All issues must be in writing and should be sent to the AT&T Project Manager. Information on how this should be done will be provided during the implementation project team meetings.
- During Participant Training, a one-page job aid is provided with a reminder of how to contact AT&T for additional assistance.
- The Participant will be provided a Satisfaction Survey at the conclusion of the project.

AT&T Responsibilities –

- Develop test plan and conduct all SYSaaS testing and turn-up of services with the Participant.
- Coordinate testing schedule and tasks with Participant’s coordinator.
- At the completion of the installation of the service described in the agreed upon project plan, the Project Manager will conduct a completion / closeout meeting with the Participant.

State Responsibilities –

- Review test plans and ORT results.
- Track progress during turn-up, attend on-site as needed.

Post-Implementation and LifeCycle Management Phase:

Participant Responsibilities –

- Report any and all service issues, facility and equipment changes, point of contact updates to AT&T and State.
- Continuity of Operations Planning (COOP), including maintaining alternative routing paths on the SYSaaS policy store. Participant agrees that such policy store rules will be in compliance with the SYSaaS and will be in general compliance with industry standards, such as NENA, for NextGen9-1-1 call routing as deemed appropriate for Wisconsin by the State or 9-1-1 Subcommittee.



- Coordinate with State and AT&T on system upgrades and future capabilities. The Participant agrees to provide 24/7/365 access to AT&T, as coordinated with the Participant, for scheduled and emergency maintenance of all SYSaaS equipment and components installed in the PSAP in accordance with the access terms contained within this Participation Agreement. The Participant agrees to periodic inspections of the equipment and audits of its use by the State or AT&T in accordance with the access terms contained within this Participation Agreement. Any such audit shall be conducted during regular business hours at the facility at which the SYSaaS is being used, and all reasonable efforts shall be made to avoid unreasonable interference with the Participant's business activities. The Participant agrees to work with the State and AT&T to resolve any facility or use related issues determined to be having any adverse impact on the Participant or other agencies on the SYSaaS.
- Maintain an updated GIS point of contact for data maintenance and error remediation.
- Data collection for federal reporting, as requested by the State or AT&T.
- Operational and physical security of the SYSaaS at the Participant's location.
 - Maintain all security patches and current security protocols for call processing equipment (CPE).
 - Ensure proper safety precautions to prevent unauthorized operational or physical access to the SYSaaS. Only Participant staff and support personnel will be authorized to log on to the SYSaaS.
 - No Participant staff or any other unauthorized person may connect any device to any piece of equipment or component without direct authorization by the State and AT&T.
 - Participant agrees to comply with all other SYSaaS security measures as may be specified by the State or AT&T.
- Costs for additional equipment or related costs requested by the Participant. If the Participant requests a change after initial installation that results in additional costs to the State, the Participant may be required to pay some or all such related costs, depending on the nature and scope of the requested change, as determined by the State.
- Any and all costs associated with any replacement of the SYSaaS equipment, components or software installed in the PSAP that are damaged or rendered inoperable due to the improper use or negligence by the Participant, as determined by the State or AT&T.

AT&T Responsibilities –

- Maintain the SYSaaS, including system security associated with the SYSaaS in accordance with the terms of the Contract and all subcontractor provided Services.
- Maintain AT&T 9-1-1 Resolution Center and respond to PSAP trouble tickets and assist in resolving issues.
- Report service issues identified by AT&T, facility and equipment changes, point of contact updates to Participant and State.
- Coordinate and perform scheduled and emergency SYSaaS maintenance.
- Coordinate with State and PSAP on system upgrades and future capabilities.
 - SYSaaS equipment, components or software installed in the Participant's facilities that is faulty or fails under normal use conditions will be replaced at no cost to the State or Participant.



- Periodic equipment, component or software lifecycle replacements or upgrades will be performed by AT&T at no cost to the State or Participant.

State Responsibilities –

- Under the Contract, State will cover monthly recurring costs for:
 - PSAP and core connections
 - Call access network
 - Project management for system implementation
 - Service management and maintenance after implementation, including AT&T 9-1-1 Resolution Center services
 - ECaTS reporting system, including the:
 - Reporting dashboard/portal
 - Management Information System (MIS) reporting
 - NG9-1-1 i3 reporting
 - Text-to-911 reporting
 - Wireless Routing Analysis Module
- Federal and State reporting on behalf of Wisconsin regarding 9-1-1 fee usage and NG9-1-1 implementation status.
- Coordinate with PSAP and AT&T on system upgrades and future capabilities.
- Review change order requests that would impact contract terms or monthly costs.

Definitions and Acronyms

Term	Acronym	Definition
9-1-1 Subcommittee		The governing body made up of 9-1-1 stakeholders appointed by the Governor and tasked with advising the Department of Military Affairs on NG9-1-1 in Wisconsin.
Automatic Location Identification	ALI	The automatic display at the PSAP of the caller’s address/location of the telephone and supplementary emergency services information of the location from which a call originates.
Automatic Number Identification	ANI	A system which has the ability to automatically identify the caller’s telephone number and to provide a display on CPE/CHE.
Call Handling Equipment	CHE	Communications or terminal equipment located in the PSAP’s facilities to receive, distribute, present and process requests for emergency assistance.
Contract		Contract #465OEC-ESIMAJ0619-00 for Statewide ESInet, NextGen Core Services, and reporting.
Continuity of Operations Plan	COOP	
Customer Premises Equipment	CPE	Communications or terminal equipment located in the PSAP’s facilities. Also see Call Handling Equipment.
Demarcation Point		The edge router placed on the Participant’s premises or such other location as may be agreed upon by the Participant and AT&T.



Emergency Call Tracking System	ECaTS	
Emergency Services IP Network	ESInet	A managed IP network that is used for emergency services communications, and which can be shared by all public safety agencies. It provides the IP transport infrastructure upon which independent application platforms and core functional processes can be deployed, including, but not restricted to, those necessary for providing Next Generation 9-1-1 services. ESInets may be constructed from a mix of dedicated and shared facilities. ESInets may be interconnected at local, regional, state, federal, national, and international levels to form an IP-based inter-network (network of networks).
Enterprise Geospatial Database Management System	EGDMS	EGDMS serves as the Spatial Interface to upload GIS data to the AT&T ESInet.
Geographic Information System	GIS	A computer software system that enabled one to visualize geographic aspects of a body of data. It contains the ability to translate implicit geographic data (such as civic address) into an explicit map location. It has the ability to query and analyze data in order to receive the results in the form of a map. It also can be used to graphically display coordinates on a map i.e., latitude/longitude from a wireless 9-1-1 call.
Master Street Address Guide	MSAG	A database of street names and house number ranges within their associated communities defining Emergency Service Zones (ESZs) and their associated Emergency Service Numbers (ESNs) to enable proper routing of 9-1-1 calls.
National Emergency Number Association i3 Standard	NENA i3	NENA Next Generation 9-1-1 standards and requirements, including without limitation, the NENA Security for Next Generation 9-1-1 Standard, and the NENA i3 Technical Requirements Documents, now available and as may become available in the future.
Network Termination Equipment	NTE	A device that connects the PSAP's data or telephone equipment to a service provider's line that comes into a building or an office.
Next Generation Core Services	NGCS	The base set of services needed to process a 9-1-1 call on an ESInet. Includes the ESRP, ECRF, LVF, BCF, Bridge, Policy Store, Logging Services, and typical IP services such as DNS and DHCP. The term "NGCS" includes the services and not the network on which they operate.
Next Generation 9-1-1	NextGen9-1-1 or NG9-1-1	A statewide emergency number system regardless of technology platform that does all of the following: a. Provides standardized interfaces for requests for emergency assistance.



		<p>b. Processes all types of requests for emergency assistance, including calls and nonvoice and multimedia messages.</p> <p>c. Acquires and integrates data useful to the delivery or routing and handling of requests for emergency assistance.</p> <p>d. Delivers requests for emergency assistance and data to appropriate public safety answering points and emergency responders.</p> <p>e. Supports data and communications needs for coordinated incident response and management.</p> <p>f. Provides a secure environment for emergency communications.</p>
Operational Readiness Testing	ORT	
Originating Service Provider	OSP	A business that provides voice and data transmission services. The services are provided over a telecommunications network that transmits any combination of voice, video and/or data between users. An OSP could be, but is not limited to, a Local Exchange Carrier (LEC), a wireless telecommunications provider, a Commercial Mobile Radio Service provider, or a PBX service provider.
Point of Interconnection	POI	A physical demarcation between an originating service provider and an NG9-1-1 network.
Public Safety Answering Point	PSAP	A facility equipped and staffed to receive 9-1-1 calls. A primary PSAP receives the calls directly. If the call is relayed or transferred, the next receiving PSAP is designated a secondary PSAP. Also referred to as an Emergency Communications Center (ECC).
Service		See System as a Service (SYSaaS).
Sensitive Personal Information	SPI	Includes, but is not limited to, names, address, telephone number, driver's license number, date of birth, health information, biometric data, social security number, and other personal information.
System as a Service	SYSaaS	The SYSaaS includes the ESInet, NGCS, and reporting all as required by Request for Proposal # MAJ0619 and all work performed, and labor, actions, recommendations, plans, research, customizations, modifications, documentation, and maintenance and support provided by AT&T necessary to fulfill that which AT&T is obligated to accomplish under this Contract. Also referred to as Service.



STATE OF WISCONSIN
MILWAUKEE AND OZAUKEE COUNTIES
VILLAGE OF BAYSIDE

A Proclamation Recognizing Bayside Communication Center Telecommunicator Jordan Trevisan for Life Saving Efforts

WHEREAS, on July 27, 2022, Bayside Communication Center Telecommunicator Jordan Trevisan answered a call of a 2-year-old child who was not breathing and did not have a pulse after a near-drowning experience; and

WHEREAS, Jordan rapidly took information, dispatched responders, and transferred the caller to the Office of Emergency Management Communications Center for pre-arrival CPR instructions; and

WHEREAS, the 2-year-old ultimately regained pulses, began breathing, and was discharged after a short hospital stay; and

WHEREAS, thanks to lifesaving efforts of Telecommunicator Jordan Trevisan taking immediate action and recognizing the severity of the medical emergency resulted in saving the life of the 2-year-old.

THEREFORE, BE IT PROCLAIMED that the Village of Bayside recognize Bayside Communication Center Telecommunicator Jordan Trevisan for life saving efforts.

VILLAGE OF BAYSIDE

Eido M. Walny, Village President

Rachel A. Safstrom, Administrative Services Director



Bayside Communications Center

August 2022

Highlights and Accomplishments

- BCC is excited to announce that we are going live with Emergency Medical Dispatching for the North Shore Communities on September 21st.
- BCC Supervisors are beginning to work on the Performance Evaluations, which are now automated in Neo Gov.
- Supervisor Gannett met with area businesses as part of his community outreach. The goal was aimed at education for loss prevention and security person, which would aid them when they needed to call BCC for assistance.
- Supervisor Gannett and Supervisor Reed attended a Neighborhood Watch meeting with Whitefish Bay Police Department and provided insight on when to call 911.

Metric	Measurement	2021 Total	2022 YTD	5 Year Average	Status (comp. 5 yr avg)
Phone Calls	Calls	116,749	71,971	110,674	
911 Calls	Calls	28,909	17,709	26,669	
911 Hang Ups	Hang Ups	3,762	2,214	26,640*	
Answer Time	Seconds	4	4	4	
Dispatch Time	Seconds	39	42	31.42	
Police Calls	Calls	70,186	53,205	74,008*	
Fire Calls	Calls	10,440	7,468	4,459**	
ALS Calls	Calls	2,967	2,200	2,656**	
Request for Police	Number of Requests	2,930	1,849	NA****	
Traffic Stops	Number of Stops	18,710	11,077	13,868*	
Training Hours	Hours	1,818	2,953	1,675	
Call Reviews	%	97.5%	98%	95%	
Retention Rate	%	65.5%	86%	69%	



Police Department

August 2022

Highlights and Accomplishments

- The annual myBlue Night Out was held on August 4th. Thank you to all the residents, area businesses and volunteers that made it a great success.
- After 48 years in law enforcement, Chief Douglass Larson retired on August 12th. He was replaced by current Chief Tom Liebenthal.
- Two police officers celebrated their respective anniversaries with the Bayside Police Department. Officer David Bunting had his 4-year anniversary on August 13th, and Officer Sarah Kadulski celebrated her 5-year anniversary on August 15th.
- Officer Cranny completed his field training, and he has been assigned to the midnight shift.
- Officer Bunting moved from the midnight shift to dayshift to fill a vacancy that existed on dayshift.

Metric	Measurement	2021 Total	2022 YTD	5 Year Average	Status (comp. 5 yr avg)
Calls for Service	Calls	5,426	3,132	5,920	●
Reports Written	# Written	1,041	520	913	●
Miles Patrolled	Miles Driven	99,603	63,414	109,325	●
Field Interviews Conducted	Contacts	113	62	111	●
Business/ Vacation Checks	Checks Performed	1,705	1,241	1473	●
Crime Prevention	Notices Given	134	125	314	●
Traffic Stops	Stops	1,830	1,219	2185	●
Citations	Citations	779	619	935	●
Warnings	Warnings	1,090	728	1022	●
Ordinance Enforcement	Tickets Issued	48	34	64	●
False Alarms	Count	72	82	75	●
Accidents Investigated	Count	65	39	84	●
Outside Agency Assists	Count	262	137	283	●
Speed Trailer Deployment	Location Count	28	8	29	●
Rx Drugs Collected	Pounds	492	370	497	●
Arrests	Arrests	113	62	144	●
myBlue Sector Activity	Count	219	62	Incomplete Data	●
Community Engagement	Contacts	48	88	Incomplete Data	●
Crimes Against Persons	Count	9	6	6	●
Crimes Against Property	Count	62	38	57	●
Crimes Against Society	County	36	19	37	●
Overtime	Hours	639	748	1048	●
Training	Hours	799	377	831	●
Code Enforcement	Notices Issued	251	161	140	●



Department of Public Works

August 2022

Highlights and Accomplishments

- The DPW spent the Majority of this month working on the stormwater/culvert project. Total numbers reported below.
- The Ellsworth Park dedication plaque and four park benches were installed at the new park bring this project to a close.
- The emotionally intelligent signs were rotated throughout the community,
- Shoulder work was completed in several areas of the community.
- This month the crew completed eighteen special pickups and installed eight mailboxes part of the replacement program.

Metric	Measurement	2021 Total	2022 YTD	5 Year Average	Target	Status (comp. 5 yr avg)
Garbage Collected	Tons	1,404	849	1,257	1,200	
Recycling Collected	Tons	475	298	510	500	
Diversion Rate	=Rec/(Rec+Garb)	25%	26%	29%	30%	
Yard Waste Collection	Stops	7,576	4,156	8,272*	7,500	
Yard Waste Collected	Yards	4,517	1,162	3,233*	2,500	
Recycling/ Clean Up Day Participants	Cars	718	697	521	800	
Access Bayside Requests	Requests Closed	695	472	718	1,000	
Special Pickups	Pickups	175	88	158	165	
Mulch Deliveries	Deliveries	76	40	60	60	
Mulch Delivered	Yards	540	340	475*	500	
Sewer Main Cleaned	Feet	30,188	0	25,232	26,000	
Manholes Rehabilitated	Manholes	3	0	3.6	67	
Ditch Line	Feet	4,532	4,750	7,620	5,000	
Culvert Replacement	Culverts	31	16	38	50	
Tree Removal	Trees	196	127	140	175	
Trees Planted	Trees	142	75	77	50	



Green Solutions Funding Agreement G98005P111

Bayside Village Hall Bioswale

1. The Parties

This Agreement is between the Milwaukee Metropolitan Sewerage District (District), 260 West Seeboth Street, Milwaukee, Wisconsin 53204-1446, and the Village of Bayside (Bayside), 9075 North Regent Road, Bayside, Wisconsin 53217.

2. Basis for this Agreement

- A. Wisconsin law authorizes any municipality to establish an intergovernmental cooperation agreement with another municipality for the furnishing of services (Wis. Stat. sec. 66.0301).
- B. The District is responsible for collecting and treating wastewater from locally-owned sewerage systems in the District's service area.
- C. During wet weather, stormwater enters the sewerage system, increasing the volume of wastewater the District must collect and treat.
- D. During wet weather, stormwater directly enters surface water, increasing pollution levels in those waterways and increasing the risk of flooding.
- E. Green infrastructure, such as constructed wetlands, rain gardens, green roofs, bioswales, and porous pavement, reduces the volume of stormwater in the sewerage system and the amount of pollutants discharged to surface waters.
- F. The District's WPDES permit includes a goal of 50 million gallons of green infrastructure detention capacity.
- G. The District wants to expedite the amount of green infrastructure installed in its service area.
- H. Bayside plans to install green infrastructure that supports the District's green infrastructure goals.

3. Date of Agreement

This Agreement becomes effective immediately upon signature by both parties and ends when Bayside receives final payment from the District or when the parties terminate this Agreement according to sec. 14 of this Agreement.

4. District Funding

The District will reimburse Bayside for the cost of the project described in the attached project description (Project), up to \$98,637. The District will provide funding after the District receives the Baseline Report and the Conservation Easement.

5. Location of Project

The project will be at the Bayside Village Hall, 9075 North Regent Road, as shown in Figure 1.

6. Baseline Report

After completion of the project, Bayside will provide a Baseline Report using forms provided or approved by the District. The Baseline Report will include:

- A. a site drawing, showing the project as completed;
- B. a topographic map of the project site;
- C. design specifications for the project, including rainwater capture capacity (maximum per storm) and other information regarding runoff rate reduction or pollutant capture;
- D. a tabulation of the bids received, including bidder name and price;
- E. a copy of the executed construction contract;
- F. a legal description of the property where the project is located, including parcel identification numbers;
- G. photographs of the completed project;
- H. a maintenance plan;
- I. an outreach and education strategy, including a description of events or activities completed or planned;
- J. an itemization of all construction costs, with supporting documentation;
- K. a W-9 Tax Identification Number form;
- L. a Small, Veterans, Women, and Minority Business Enterprise Report; and
- M. an Economic Impact Report, showing the total number of people and the estimated number of hours worked on design and construction of the Project by Bayside's employees, contractors, consultants, and volunteers.

7. Procedure for Payment

Bayside will submit an invoice to the District for the amount to be reimbursed. The invoice will document all costs to be reimbursed. Invoices from consultants will provide: their hourly billing rates, if applicable; the hours worked, by individual; and a summary of the tasks accomplished.

Bayside will send the Baseline Report to:

Andrew Kaminski, Project Manager
Milwaukee Metropolitan Sewerage District
260 West Seeboth Street
Milwaukee, Wisconsin 53204-1446

Bayside will send the invoice to apinvoice@mmsd.com. On the invoice, Bayside will identify the District project manager (Andrew Kaminski) and the funding agreement number (G98005P111).

The District will not provide reimbursement until the Project is complete and the District has received all required deliverables.

8. Changes in the Project and Modifications to the Agreement

Any changes to the Project must be approved by the District in writing in advance. The District will not reimburse for work that is not described in the original project description unless Bayside obtains prior written approval from the District.

9. Modifications to this Agreement

Any modifications to this Agreement will be in writing and signed by both parties.

10. Project Maintenance

Bayside will maintain the Project for at least ten years. If the Project fails to perform as anticipated or if maintaining the Project is not feasible, then Bayside will provide a report to the District explaining the failure of the Project or why maintenance is not feasible. Failure to maintain the Project will make Bayside ineligible for future District funding until Bayside corrects maintenance problems.

11. Permits, Certificates, and Licenses

The Bayside is solely responsible for compliance with all federal, state, and local laws and any required permits, certificates, or licenses.

12. Procurement

Bayside must select professional service providers according to the ordinances and policies of Bayside. Bayside must procure all non-professional services, such as construction, sewer inspection, and post-construction restoration, according to State of Wisconsin statutes and regulations and the ordinances and policies of Bayside. Whenever work valued over \$25,000 is procured without the use of a public sealed bidding process, the District may request and Bayside must provide an opinion from a licensed attorney representing Bayside explaining why the procurement complies with State of Wisconsin law and the ordinances of Bayside.

13. Responsibility for Work, Insurance, and Indemnification

Bayside is solely responsible for planning, design, construction, and maintenance of the Project, including the selection of and payment for consultants, contractors, and materials.

The District will not provide any insurance coverage of any kind for the Project or the Bayside.

Bayside will defend, indemnify, and hold harmless the District and its Commissioners, employees, and agents against all damages, costs, liability, and expenses, including attorney's fees and related disbursements, arising from or connected with the planning, design, construction, operation, or maintenance of the Project.

14. Terminating this Agreement

The District may terminate this Agreement at any time before the commencement of construction. After the commencement of construction, the District may terminate this Agreement only for good cause, including, but not limited to, breach of this Agreement by Bayside. Bayside may terminate this Agreement at any time, but will not receive any payment from the District if Bayside does not complete the Project.

15. Conservation Easement

After the completion of construction, the District must receive a Conservation Easement from Bayside. The Conservation Easement will be limited to the Project. The term of the Conservation Easement will be ten years. Bayside will cooperate with the District to prepare the Conservation Easement.

16. Exclusive Agreement

This Agreement is the entire agreement between Bayside and the District for the project.

17. Severability

If a court holds any part of this Agreement unenforceable, then the remainder of the Agreement will continue in effect.

18. Applicable Law

The laws of the State of Wisconsin apply to this Agreement.

19. Resolving Disputes

If a dispute arises under this Agreement, then the parties will try to resolve the dispute with the help of a mutually agreed-upon mediator in Milwaukee County. The parties will equally share the costs and fees associated with the mediation, other than attorney’s fees. If the dispute is not resolved within 30 days after mediation, then either party may take the matter to court.

20. Notices

All notices and other communications related to this Agreement will be in writing and will be considered given as follows:

- A. when delivered personally to the recipient's address as stated in this Agreement; or
- B. three days after being deposited in the United States mail, with postage prepaid to the recipient's address as stated in this Agreement.

21. Independence of the Parties

This Agreement does not create a partnership. Bayside does not have authority to make promises binding upon the District or otherwise have authority to contract on the District's behalf.

22. Assignment

Bayside may not assign any rights or obligations under this Agreement without the District's prior written approval.

23. Public Records

Bayside will produce any records in the possession of Bayside that are subject to disclosure by the District pursuant to the State of Wisconsin’s Open Records Law, Wis. Stats. secs. 19.31 to 19.39. Bayside will indemnify the District against all claims, demands, or causes of action resulting from the failure to comply with this requirement.

Signatures on Next Page

**MILWAUKEE METROPOLITAN
SEWERAGE DISTRICT**

VILLAGE OF BAYSIDE

By: _____

Kevin L. Shafer, P.E.
Executive Director

By: _____

Andy Pederson
Village Manager

Date: _____

Date: _____

Approved as to Form

By: _____

Attorney for the District

Green Solutions Funding Agreement G98005P111

Bayside Village Hall Bioswale

Project Description

Bayside owns and maintains a swale along the west side of the Village Hall and Department of Public Works Campus at 9075 North Regent Road. This swale is adjacent to the Union Pacific Railroad. The swale collects and carries water from the intersection of Regent Road and Santa Monica Boulevard to where it crosses Fairy Chasm Road and eventually to Fish Creek at the bottom of a large ravine. A segment of the swale next to the Village Hall parking lot and the Department of public works collects runoff from over ¼ of an acre of impervious area.

Bayside will design and construct a new biofiltration swale in place of the conventional ditch to help capture and store stormwater. The design will include clearing the existing swale and creating a biofiltration cross section in the ditch that will promote stormwater capture. The bioretention facility will be approximately 1,000 ft long and have a storage layer of washed stone 1.5 feet deep and a layer of engineered soil 1 foot deep. The engineered soil will comply with the DNR technical standard.

Schedule

Bayside will complete construction no later than July 1, 2023.

Budget

The estimated cost is \$80,000 for construction and \$18,000 for engineering and inspection services for a total cost of \$98,000.

Outreach and Education

Bayside will post educational signage or describe the project and its benefits in a community newsletter or web page.

Educational materials will acknowledge District funding for the project.

Signage will:

1. be either designed and provided by the District or provided by Fox Point and approved by the District,
2. be at a location approved by the District, and
3. identify the District as funding the green infrastructure by name, logo, or both.

Figure 1
Bioswale Location

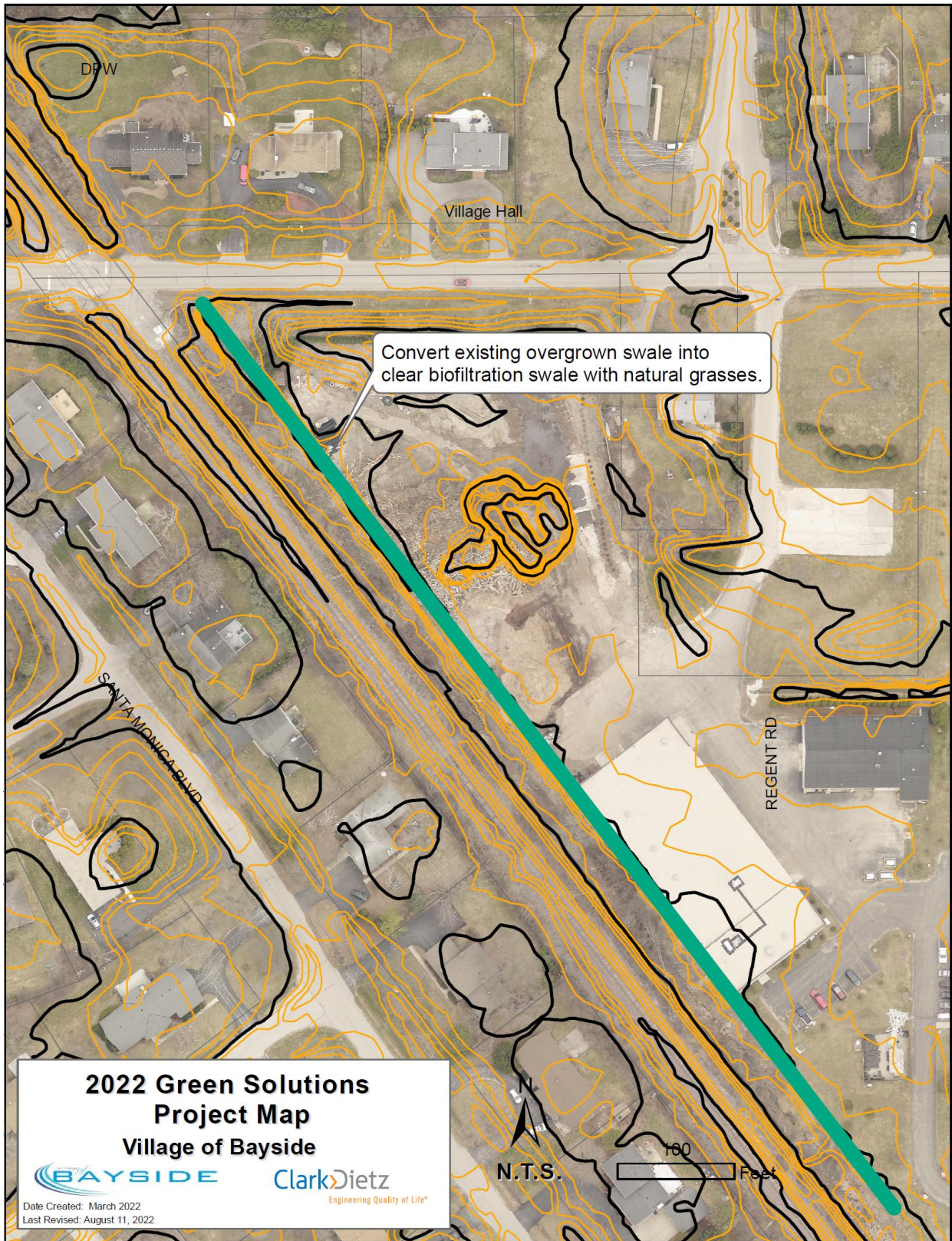

NORTH SHORE FIRE/RESCUE

Office of the Fire Chief

Robert Whitaker

To: Village Boards/Common Council
Date: September 1, 2022
Subject: 2023 Fee Schedule

Enclosed is the proposed 2023 Fee for Service Schedule and Resolution 22-01 for your consideration.

The Fee Schedule is annually updated by the Board of Directors and requires that at least five of the seven member municipalities pass a local resolution regarding the fee schedule at the Council/Board level. There are three different types of fees charged by the Department, fees for emergency services, fees for fire prevention permits/inspections and administrative fees. The North Shore Fire Department Board recommended approval of this fee schedule to the member municipalities at its September 6, 2022 Meeting.

Fees for Emergency Services

This area primarily consists of fees for emergency medical services provided by the Department. Since 2013, the Board has recommended adjustment of EMS fees based on the average change year-to-year in the Medical Care Commodities and Medical Care Service CPI.

The average of the CPI factors referenced earlier for 2022 is 4.4%. It is my recommendation that if the Board wishes to continue to use this CPI as a barometer for the fee changes, the Board adjust EMS Fees up by 4.4%.

Fire Prevention Permits/Inspections

The fee schedule in this area has no changes from 2022.

Administrative Fees

The fee schedule in this area has no changes from 2022.

STATE OF WISCONSIN
MILWAUKEE AND OZAUKEE COUNTIES
VILLAGE OF BAYSIDE

RESOLUTION NO: 22-__

A Resolution Approving the 2023 North Shore Fire Department Fees For Service Schedule

WHEREAS, the Board of Directors of the North Shore Fire Department has recommended that the 2023 North Shore Fire Department Fees for Services, attached to and made a part of this Resolution (hereinafter the "Service Fees"), be approved by each of the municipalities a party to the 1994 Amended and Restated North Shore Fire Department Agreement (hereinafter "the Agreement"); and

WHEREAS, the Agreement requires that all fees for service must be submitted to the governing bodies of the Villages of Bayside, Brown Deer, Fox Point, River Hills, Shorewood and Whitefish Bay and the City of Glendale for approval by not less than five (5) of these seven (7) municipalities; and

WHEREAS, upon approval by not less than five (5) of these seven (7) municipalities the appropriate North Shore Fire Department officials are authorized to charge and collect the Service Fees; and

THEREFORE, BE IT RESOLVED that, Eido M. Walny, Village President and the Village Board of Trustees hereby approves the Service Fees in the form presented as attached and directs the Bayside Clerk to provide a certified copy of this Resolution to the North Shore Fire Department.

PASSED AND ADOPTED by the Village Board of Trustees of the Village of Bayside this twenty-second day of September, 2022.

VILLAGE OF BAYSIDE

Eido M. Walny, Village President

Rachel A. Safstrom, Administrative Services Director

Item	2022	2023
BLS service and/or treatment without transport (Resident)	140.72	146.92
BLS service and/or treatment without transport (Non-Resident)	210.40	219.66
BLS service lift assist not in EMS High-Utilizer Program	209.69	218.92
Paramedic service and/or treatment without transport (Resident)	174.88	182.58
Paramedic service and/or treatment without transport (Non-Resident)	239.10	249.62
BLS service with transport (Resident)	850.51	887.93
BLS service with transport (Non-Resident)	982.34	1025.56
Paramedic service with transport Level - ALS-1 (Resident)	970.78	1013.49
Paramedic service with transport Level - ALS-2 (Resident)	1067.05	1114.00
Paramedic service with transport Level - ALS-1 (Non-Resident)	1094.37	1142.53
Paramedic service with transport Level - ALS-2 (Non-Resident)	1262.42	1317.97
Paramedic service and invasive treatment without transport (Resident)	174.88	182.58
Paramedic service and invasive treatment without transport (Non-Resident)	245.93	256.75
Defibrillation	161.75	168.87
IV and supplies	84.71	88.44
Intubation	182.82	190.87
ALS supplies	134.79	140.72
Oxygen and supplies	105.20	109.83
Mileage (rate per loaded mile)	22.65	23.64
EKG	140.72	146.92
Drugs, Group-1: Albuterol, Amioderone (30 mg), Aspirin, Atropine, Benadryl, Calcium Gluconate, D10, Duoneb, D5W, Glucose (oral), Nitroglycerin, Sodium Normal Saline (bags & carpujet), Zofran Tabs, Zofran IV, acetaminophen/Tylenol, Ketorolac/Torodol	45.09	47.07
Drugs, Group-2: Calcium Chloride, Lidocaine	51.92	54.20
Drugs, Group-3: Cardizen/Diltiazem, Fentanyl, Ketamine, Midazolam, Narcan, Noephinephrine, Epinephrine, Sodium Bicarbonate	66.95	69.89
Dexamethasone	81.98	85.59
Epinephrine by Epi-pen	133.89	139.78
Adenosine	125.70	131.23
Glucagon, up to 1 Mg	226.45	236.41
Solmedrol, 41-125 Mg	81.98	85.58
E-Z IO	168.05	175.44
Spinal Immobilization	174.88	182.58
Triage barcode wristbands	4.10	4.28
Cyano-kits	1482.71	1547.95
CPAP mask	75.48	78.80
LUCAS Suction Cup and ResQPOD	258.75	270.14

Fire Prevention Permits/Inspections:

	2022	2023
Fire Department Services for Vehicles	\$500	\$500
Occupancy Inspection	\$75.00 (\$25/multi-family unit with \$75 minimum)	\$75.00 (\$25/multi-family unit with \$75 minimum)
Work without Permit	Double normal fee	Double normal fee
Re-inspection Fee	\$75	\$75
Special Plan Review/Inspection	Subject to actual cost	Subject to actual cost
Variance Requests	\$100/code section	\$100/code section
Inspection Request (less than 72 hrs notice)	\$75/hr 2 hr. minimum	\$75/hr 2 hr. minimum
Inspection Non-Business Hours	\$100/hr 2 hr. minimum	\$100/hr 2 hr. minimum

Plan Review (Includes Site Inspection):

	2022	2023
Construction Compliance with Fire Code	\$.07/sq. ft. (\$75 minimum)	\$.07/sq. ft. (\$75 minimum)
Performance Based or Alternative Design	\$.07/sq. ft. (\$100 minimum)	\$.07/sq. ft. (\$100 minimum)
Fire Alarm and Detection Systems	\$.07/sq. ft. (\$75 minimum)	\$.07/sq. ft. (\$75 minimum)
Audio/Visual Annunciation Systems	\$250 up to 20 devices, \$500 over 20 devices	\$250 up to 20 devices, \$500 over 20 devices
Hood and Duct Suppression Systems	\$100 per system	\$100 per system
Other Suppression Systems (FM200, Cardox, etc.)	\$100/plan	\$100/plan
Smoke Evacuation	\$75/plan	\$75/plan
Water-based Sprinkler Systems (new or altered <20 heads)	100	100
Water-based Sprinkler Systems (new or altered >20 heads)	\$.07/sq. ft. (\$100 minimum)	\$.07/sq. ft. (\$100 minimum)
Spray Booth Operations	100	100

Acceptance Tests:

	2022	2023
Hydro-test of Sprinkler Piping (2 hr. test)	\$125	\$125
Fire Pump	\$100	\$100
Fire Alarm and Detection System	\$100	\$100
Hood and Duct Suppression System	\$100	\$100
Other Suppression	\$100	\$100
Smoke Evacuation System	\$100	\$100
Spray Booth System	\$100	\$100

Other Permit Items:

	2022	2023
--	-------------	-------------

Bonfires, Cermonial Fires, Vegetation Burns	\$50	\$50
Hot Work	\$25	\$25
Indoor Vehicle Exhibits	\$25	\$25
Building Demolition	\$250	\$250
Tents for Public Assembly >400 sq. ft.	\$50	\$50
Temporary Fuel Storage	\$50	\$50
Fireworks Displays	\$125	\$125
Code Consulting/Emergency Planning	\$75/hour	\$75/hour

Administrative/Other Fees:

	2022	2023
CPR Certification Skill Check-Off Only	\$55/student	\$55/student
CPR Certification	\$75/student	\$75/student
Open Records Requests	\$.10/page	\$.10/page
Record Locating Fees	As determined by the record custodian only if over \$50 per request.	As determined by the record custodian only if over \$50 per request.
Event Stand-by	Cost of personnel (loaded wage), vehicles/ supplies, plus 25% administrative fee.	Cost of personnel (loaded wage), vehicles/ supplies, plus 25% administrative fee.

NORTH SHORE FIRE/RESCUE

Office of the Fire Chief

Robert Whitaker

To: NSFD Member City Council/Village Boards
Date: September 1, 2022
Subject: Resolution 22-02

Section 66.0602(3)(h) provides that levy limits otherwise applicable to municipalities under Chapter 66 of Wisconsin Statutes do not apply to the amount that a city or village may levy in that year to pay for charges assessed by a joint fire department to the extent that the amount levied to pay for such charges would cause the city or village to exceed the limits imposed under Section 66.0602, Wis. Stats.

The exemption applies if the total charges assessed by the Department for the budget year do not exceed the previous year's charges by a percentage that is less than or equal to the percentage change in the US Consumer Price Index for all urban consumers, US City Average, as determined by the US Department of Labor for the 12 months ending on September 30th of the year of the levy plus 2%. Additionally, the Statute requires that for the exemption to be applicable, the governing bodies of all the cities and villages served by the Department must adopt a resolution in favor of exceeding such levy limit.

The applicable CPI change is 7.92% (estimated), so under State Statute, the allowable increase is 9.92%. The Department's actual increase in charges is 3%.

It is my understanding that several member municipalities are interested in using the levy limit exemption for 2023. The North Shore Fire Department Board of Directors voted to recommend approval of this resolution to the seven member communities at its meeting on September 6, 2022. Enclosed is a resolution for consideration by each member municipality. It is important each community consider this resolution prior to November 15, 2022.

If approved, please forward a signed copy of your municipality's resolution.

STATE OF WISCONSIN
MILWAUKEE AND OZAUKEE COUNTIES
VILLAGE OF BAYSIDE
RESOLUTION NO: 22-___

In the Matter of Authorizing an Exception to the Levy Limits for Charges for the North Shore Fire Department Pursuant to 2005 Wisconsin Act 484

WHEREAS, the Village of Bayside is a participating member of the North Shore Fire Department under the North Shore Fire Services Agreement; and

WHEREAS, the Wisconsin Legislature has enacted 2005 Wisconsin Act 484 on May 30, 2006, published on June 13, 2006; and

WHEREAS, Act 484 creates Section 66.0602(3)(h), Wis. Stats., which statute provides that levy limits otherwise applicable do not apply to the amount that a city or village may levy in that year to pay for charges assessed by a joint fire department to the extent that the amount levied to pay for such charges would cause the city or village to exceed the limits imposed under Section 66.0602, Wis. Stats.; and

WHEREAS, the exception to the levy limit applies only if the total charges assessed by the joint fire department for the current year increase, relative to the total charges assessed for the previous year, by a percentage that is less than or equal to the percentage change in the US Consumer Price Index for all urban customers, US city average, as determined by the US Department of Labor for the 12 months ending on September 30th of the year of the levy, plus 2%; and

WHEREAS, the exception to levy limits under Act 484 further only applies if the governing body of each city and village served by the North Shore Fire Department adopts a resolution in favor of exceeding such levy limit as may be applicable;

NOW THEREFORE, BE IT RESOLVED that, Eido M. Walny, Village President and the Village Board of Trustees hereby authorizes a levy for charges assessed by the joint fire department which exceeds the limit as described and imposed by Section 66.0602, Wis. Stats., but only to the extent as authorized by Section 66.0602(3)(h)2a, Wis. Stats., and

BE IT FURTHER RESOLVED that this resolution shall not be construed as authorizing the North Shore Fire Department to adopt any particular budget, but rather that the Act 484 budget formula shall be deemed a maximum limit on any budget increase which is duly adopted under all applicable procedures and requirements of the North Shore Fire Services Agreement.

PASSED AND ADOPTED by the Village Board of Trustees of the Village of Bayside this twenty-second day of September, 2022.

VILLAGE OF BAYSIDE

Eido M. Walny, Village President

Rachel A. Safstrom, Administrative Services Director



Administrative Services

August 2022

Highlights and Accomplishments

- Completed annual renewal of insurance for CVMIC as well as the Worker's Compensation projection information for 2023.
- Conducted a successful Partisan Primary Election.
 - 1,536 voters – (45.15% of registered voters)
 - 52 new registrations
 - 635 absentee ballots returned (41.34% of the total vote)
- Continued to work on 2023 budget information.
- Attended session with Milwaukee County Treasurers to review updates to the new tax collection software. Began process of testing Bayside data.
- Completed final tax settlement for 2021 taxes collectable in 2022.

Metric	Measure	YTD%	Measure	YTD%
General Fund	Revenue	94.1%	Expenditure	%
BCC	Revenue	81.2%	Expenditure	56.8%

Metric	Measure	YTD%	Measure	YTD%
Sanitary Sewer	Revenue	96.0%	Expenditure	32.0%
Storm Water	Revenue	84.2%	Expenditure	36.8%

Metric	Measurement	2021 Total	2022 YTD	5 Year Average	Target	Status (comp. 5 yr avg)
Grants	\$	\$434,644	\$951,586	\$334,424	\$300,000	
Property Status	Number	130	79	126	120	
Total Permits	Number	328	473	571	400	
Public Meetings	Number	62	33	54	55	
Ordinances	Number	5	9	10	15	
Resolutions	Number	30	15	28	25	
Communications Reach	Digital Interactions	420,598	180,874	303,407	450,000	
SCF Created	Number	2,820	1,792	1,950	2,700	
SCF DTA	Number	0.5	0.2	1.22	1	
SCF DTC	Number	7.2	2.8	13.2	7	
SCF SLA Days	% in SLA	84%	91%	73.8%	90%	
Elections	Number	2	3	2.8	4	
Votes Cast	Number	1,664	3,629	3,833	7,250	



411 East Wisconsin Avenue
Suite 2400
Milwaukee, Wisconsin 53202-4428
414.277.5000
Fax 414.271.3552
www.quarles.com

Attorneys at Law in
Chicago
Indianapolis
Madison
Milwaukee
Minneapolis
Naples
Phoenix
Tampa
Tucson
Washington, D.C.

September 7, 2022

VIA EMAIL

Ms. Rachel Safstrom
Administrative Services Director
Village of Bayside
Village Hall
9075 North Regent Road
Bayside, WI 53217

Re: Redemption of \$10,000 of the Special Assessment B Bonds, Series 2013A, dated May 16, 2013 (the "2013A Bonds") and \$40,000 of the Special Assessment B Bonds, Series 2015A, dated May 7, 2015 (the "2015A Bonds")

Dear Ms. Safstrom:

Ehlers & Associates, Inc. asked us to prepare the attached **Resolution** to call \$10,000 of the 2013A Bonds and \$40,000 of the outstanding 2015A Bonds for redemption. It is our understanding that this resolution will be considered by the Village Board at a meeting to be held on September 22, 2022.

If you have not already done so, please include the title of the Resolution on the agenda for the meeting. Please then post the agenda in at least three public places and provide it to the official newspaper of the Village (or if the Village has no official newspaper, to a news medium likely to give notice in the area) and to any other requesting media at least twenty-four hours prior to the meeting (see Section 19.84(1)(b), Wisconsin Statutes). **If the meeting will be a virtual meeting, please be sure to include on the agenda and the notices the dial-in number or other information necessary for the public and the media to access and monitor the meeting.** The attached **Certificate of Compliance with Open Meeting Law** must be completed in connection with the Village Board meeting at which the Resolution is adopted.

Ms. Rachel Safstrom
September 7, 2022
Page 2

A vote of at least a majority of a quorum of the Village Board is necessary to adopt the Resolution. The Resolution should be adopted in the same manner as other resolutions of the Village are adopted. Please complete the attached **Excerpts of Minutes** form to record the attendance at the meeting and vote on the Resolution.

Following the adoption of the Resolution, please return an executed copy to us together with an executed copy of the Excerpts of Minutes and the Certificate of Compliance With Open Meeting Law.

Directions as to how to provide notice of redemption of the 2013A Bonds and the 2015A Bonds are contained in the Resolution and the Notice of Call attached to it. We understand that Ehlers & Associates, Inc. will assist you in distribution of the Notice.

If you have any questions regarding these documents or any other matter, please do not hesitate to call me at (414) 277-5790.

Very truly yours,

QUARLES & BRADY LLP



Bridgette J. Keating

BJK:TAB

Enclosures

cc: Mr. Andrew Pederson (w/enc. via email)
Mr. Joe Murray (w/enc. via email)
Mr. Todd Taves (w/enc. via email)
Ms. Sara Beecher (w/enc. via email)
Ms. Annie Mallon (w/enc. via email)
Ms. Kathy Myers (w/enc. via email)
Mr. Keith Schmitz (w/enc. via email)
payingagent@ehlers-inc.com (w/enc. via email)
Ms. Tracy Berrones (w/enc. via email)

Resolution No. _____

RESOLUTION AUTHORIZING THE PARTIAL REDEMPTION OF
SPECIAL ASSESSMENT B BONDS, SERIES 2013A
DATED MAY 16, 2013 AND
SPECIAL ASSESSMENT B BONDS, SERIES 2015A
DATED MAY 7, 2015

WHEREAS, the Village of Bayside, Milwaukee and Ozaukee Counties, Wisconsin (the "Village") issued Special Assessment B Bonds, Series 2013A, dated May 16, 2013 (the "2013A Bonds") and Special Assessment B Bonds, Series 2015A, dated May 7, 2015 (the "2015A Bonds") (collectively, the "Bonds"); and

WHEREAS, the Village has received prepayment of certain special assessments payable in installments and in anticipation of which the Bonds were issued ("Special Assessment Prepayments"); and

WHEREAS, the Bonds are required to be partially redeemed on any principal or interest date after Special Assessment Prepayments are received in such a manner that the remaining principal maturities shall be as equal as possible; and

WHEREAS, the Village has determined that it is necessary, desirable and in the best interest of the Village to prepay a total of \$10,000 of the 2013A Bonds and redeem \$5,000 of certain maturities or mandatory redemption payments (the "Prepaid 2013A Bonds") on November 1, 2022 as more fully described on Exhibit A attached hereto and incorporated herein by this reference with the Special Assessment Prepayments;

WHEREAS, the Village has determined that it is necessary, desirable and in the best interest of the Village to prepay a total of \$40,000 of the 2015A Bonds and redeem \$5,000 of certain maturities (the "Prepaid 2015A Bonds") on November 1, 2022 as more fully described on Exhibit B attached hereto and incorporated herein by this reference with the Special Assessment Prepayments;

NOW, THEREFORE, BE IT RESOLVED by the Village Board of the Village that the Prepaid 2013A Bonds and the Prepaid 2015A Bonds are called for prior payment on November 1, 2022, at the price of par plus accrued interest to the date of redemption.

The Village Clerk is hereby directed to work with Ehlers and Associates, Inc. ("Ehlers") to cause timely notice of the call of the Prepaid 2013A Bonds and the Prepaid 2015A Bonds by providing notice in substantially the form attached hereto as Exhibit A and Exhibit B. All actions heretofore taken by the officers and agents of the Village to effectuate the redemption of the Prepaid 2013A Bonds and the Prepaid 2015A Bonds are hereby ratified and approved.

The Village Board hereby ratifies and approves the retention of Ehlers to provide financial advisory services in connection with this transaction and Quarles & Brady LLP to provide legal services in connection with this transaction.

Passed and Approved this 22nd day of September, 2022.

President

Attest:

Village Clerk

EXHIBIT A

NOTICE OF PARTIAL CALL*

VILLAGE OF BAYSIDE
MILWAUKEE AND OZAUKEE COUNTIES, WISCONSIN
SPECIAL ASSESSMENT B BONDS, SERIES 2013A
DATED MAY 16, 2013

NOTICE IS HEREBY GIVEN that the Bonds of the above-referenced issue which mature on the date and in the amounts; bear interest at the rate; and have CUSIP No. as set forth below have been called for prior payment on November 1, 2022 at a redemption price equal to 100% of the principal amount thereof plus accrued interest to the date of prepayment:

<u>Maturity Date</u>	<u>Principal Amount</u>	<u>Interest Rate</u>	<u>CUSIP No.</u>
5/1/2033 ¹	\$10,000 ¹	4.15%	073152AU4 ^{**}

Upon presentation and surrender of said Bonds to Bond Trust Services Corporation, Roseville, Minnesota, the registrar and fiscal agent for said Bonds, the registered owners thereof will be paid the principal amount of the Bonds plus accrued interest to the date of prepayment.

Said Bonds will cease to bear interest on November 1, 2022.

By Order of the
Village Board of the Village of Bayside
Village Clerk

Dated _____

¹ As a result of this redemption, the principal amount of Bonds paid through mandatory redemption in the year 2032 and maturing in the year 2033 will be reduced by \$5,000.

* To be provided to Bond Trust Services Corporation at least thirty-five (35) days prior to November 1, 2022. The registrar and fiscal agent shall be directed to give notice of such prepayment by registered or certified mail, overnight express delivery, facsimile or electronic transmission or in any other manner required by the Depository, to The Depository Trust Company, Attn: Supervisor, Call Notification Department, 570 Washington Blvd., Jersey City, NJ 07310, not less than thirty (30) days prior to November 1, 2022. This Notice should be filed electronically with the MSRB through the Electronic Municipal Market Access (EMMA) System website at www.emma.msrb.org.

** Represents a portion of the principal amount outstanding of this maturity.

EXHIBIT B

NOTICE OF PARTIAL CALL*

VILLAGE OF BAYSIDE
MILWAUKEE AND OZAUKEE COUNTIES, WISCONSIN
SPECIAL ASSESSMENT B BONDS, SERIES 2015A
DATED MAY 7, 2015

NOTICE IS HEREBY GIVEN that the Bonds of the above-referenced issue which mature on the dates and in the amounts; bear interest at the rates; and have CUSIP Nos. as set forth below have been called for prior payment on November 1, 2022 at a redemption price equal to 100% of the principal amount thereof plus accrued interest to the date of prepayment:

<u>Maturity Date</u>	<u>Principal Amount</u>	<u>Interest Rate</u>	<u>CUSIP No.</u>
5/1/2023	\$5,000	2.45%	073152BB5**
5/1/2024	5,000	2.60	073152BC3**
5/1/2030	5,000	3.50	073152BJ8**
5/1/2031	5,000	3.65	073152BK5**
5/1/2032	5,000	3.80	073152BL3**
5/1/2033	5,000	3.90	073152BM1**
5/1/2034	5,000	4.00	073152BN9**
5/1/2035	5,000	4.10	073152BP4**

The Village shall deposit federal or other immediately available funds sufficient for such redemption at the office of The Depository Trust Company on or before November 1, 2022.

Said Bonds will cease to bear interest on November 1, 2022.

By Order of the
Village Board of the Village of Bayside
Village Clerk

Dated _____

* To be provided by registered or certified mail, overnight express delivery, facsimile or electronic transmission or in any other manner required by the Depository, to The Depository Trust Company, Attn: Supervisor, Call Notification Department, 570 Washington Blvd., Jersey City, NJ 07310, not less than thirty (30) days nor more than sixty (60) days prior to November 2, 2022. This Notice should be filed electronically with the MSRB through the Electronic Municipal Market Access (EMMA) System website at www.emma.msrb.org.

** Represents a portion of the principal amount outstanding of this maturity.

SERVICE AGREEMENT

This Agreement is between the Village of Brown Deer, Milwaukee County, WI (hereinafter referred to as "Village") and the Village of Bayside (hereinafter referred to as "Service Provider") for IT services (hereinafter referred to as the "Project"). In consideration of the mutual agreements contained herein, the Village and Service Provider agree as follows:

1. The Village will:

- a. The Village will pay the Service Provider \$74,100 in 2023; \$79,000 in 2024; and \$82,900 in 2025. Invoices will be sent in advance and shall be paid quarterly by January 1, April 1, July 1, September 1, of each year. Between October 1, 2022 and December 31, 2022, the Village will shall pay the Service Provider one-quarter of the 2023 fee, or \$18,525, to be paid upon execution of this Agreement. To expedite payment of invoices under this Agreement, the invoices should be sent to the following:

Tyler Burkart, Village Manager

- b. Identify daily tasks that need completion through ticketing software offered by the Service Provider. Employees shall follow up with department head (or Village Manager when appropriate) to make an official IT request.
- c. Provide any current documentation and capital asset list to Service Provider so that the Service Provider can update as changes are approved and made.
- d. Locate a general working space for any staff with the Service Provider to utilize when working onsite.

2. The Service Provider will:

- a. Perform services requested by the Village, which includes but not limited to: server integration and migration, network services, wireless, network security, backup and recovery, consulting, telephone system support, unified communications, call recording and reporting, mobility solutions, VOIP and IP network assessment, implementation services and support, structured cabling, video surveillance, long-range planning, facility services, and paging.
- b. Provide a total of 1,040 hours annually (or per 12 month period beginning with execution of this Agreement), inclusive of onsite and remote support. While it is anticipated that this work will average approximately 20 hours per week, some weeks will be less than 20 hours and some more than 20 hours. For any hours exceeding 1,040 annually, or any hours exceeding 1,040 in the 12 month period beginning with execution of the Agreement, the Village will pay \$100 per hour for those services.

- c. Serve as consultative interface for the customer in dealing with third parties such as application providers, software applications, Internet service providers, and telecommunications circuit providers.
- d. Provide monthly report summarizing status of current projects and tasks.
- e. Communicate with Village Manager and department heads with feedback on regular IT tasks and upcoming projects/initiatives. Meet with Village personnel on as needed basis with Village Manager to review expectations, projects, anticipated needs, etc.
- f. Document all procedures and operations related to IT general maintenance and provide access to documented procedures to Village staff.
- g. Update and manage the annual IT asset list outlining all IT related capital expenses. Document is attached.
- h. Generate plan communicating all proposed IT projects for the upcoming year and five years with Village Manager, Finance Director, and appropriate department head(s) by June of each year. Make changes in the asset list to reflect changes once approved by the Village Manager.
- i. Review the proposed annual budget to assure all IT approved projects are included.
- j. Present best IT practices in the industry when proposing budget and capital expenses to proactively address IT related security and performance concerns.

3. Duration.

This Agreement will become effective October 1, 2022 through December 31, 2025. This Agreement may be cancelled on ninety (90) days written notice of either party.

4. Use of Village Name

It is understood and agreed that the name of the Village and the municipal location may not be used by the Service Provider or its agents in any promotional materials without prior approval of the Village.

5. Independent Contractor.

It is understood and agreed that the Service Provider is an independent contractor for the performance of all services described within this Agreement.

6. Assignment.

This Agreement and interests hereunder are not to be assigned.

7. **Liability.**
The Village represents that it does not carry any insurance covering liability of its independent contractors, including the Service Provider. Service Provider is solely responsible for obtaining any insurance coverage that may be necessary to carry out its business, including workers compensation coverage and/or liability coverage as dictated by state statute. Nothing in this agreement is intended to abrogate the immunities or limitations of liability as enumerated in Wis. Stat. § 893.80 that may be asserted by either the Village or the Service Provider.
8. **Wisconsin Law.**
This Agreement shall be governed by and construed with the laws of the State of Wisconsin.
9. **Complete Agreement.**
This Agreement represents the entire of listing of the terms between the parties. This Agreement may be modified only in writing by an amendment signed by both parties.
10. **Endorsement.**
By endorsing this Agreement both the Service Provider and the Village indicate that each has the authority to bind to the terms of this Contract.

Village of Brown Deer

Village of Bayside

Tyler Burkart, Village Manager

Andrew Pederson, Village Manager

Date

SERVICE AGREEMENT

This Agreement is between the Village of Shorewood, Milwaukee County, WI (hereinafter referred to as "Village") and the Village of Bayside (hereinafter referred to as "Service Provider") for IT services (hereinafter referred to as the "Project"). In consideration of the mutual agreements contained herein, the Village and Service Provider agree as follows:

1. The Village will:

- a. The Village will pay the Service Provider \$105,000 in 2023. In 2024 2025, and extensions thereof, the increase would be limited to the Village of Shorewood levy limit increase plus 1%. Invoices will be sent in advance and shall be paid quarterly by January 1, April 1, July 1, September 1, of each year. To expedite payment of invoices under this Agreement, the invoices should be sent to the following:

Chris Anderson, Assistant Village Manager
Shorewood Village Hall
3930 N. Murray Avenue
Shorewood, WI 53211

- b. Identify daily tasks that need completion through ticketing software offered by the Service Provider. Employees shall follow up with department head (or Assistant Village Manager when appropriate) to make an official IT request.
- c. Provide any current documentation and capital asset list to Service Provider so that the Service Provider can update as changes are approved and made.
- d. Locate a general working space for any staff with the Service Provider to utilize when working onsite.

2. The Service Provider will:

- a. Perform services requested by the Village, which includes but not limited to: server integration and migration, network services, wireless, network security, backup and recovery, consulting, telephone system support, unified communications, call recording and reporting, mobility solutions, VOIP and IP network assessment, implementation services and support, structured cabling, video surveillance, long-range planning, facility services, and paging.
- b. Provide forty (40) hours of onsite and remote support per week. There are no additional charges for normal and routine services during

business hours or for after hour mission critical emergencies on 24 hours, 7 days a week, 365 days a year basis.

- c. Serve as consultative interface for the customer in dealing with third parties such as application providers, software applications, Internet service providers, and telecommunications circuit providers.
- d. Provide weekly status updates to the Village Manager and Assistant Village Manager; and a detailed monthly report summarizing status of current projects and tasks.
- e. Conduct a quarterly meeting with the Village detailing the status of organization-specific projects as well as an understanding of all priorities under the Service Provider's purview (other municipalities, North Shore Fire Department, etc.).
- f. Communicate with Village Manager, Assistant Village Manager, and department heads with feedback on regular IT tasks and upcoming projects/initiatives. Meet with Village personnel on as needed basis with Village Manager and Assistant Village Manager to review expectations, projects, anticipated needs, etc.
- g. Document all procedures and operations related to IT general maintenance and provide access to documented procedures to Village staff.
- h. Update and manage the annual IT asset list outlining all IT related capital expenses. Document is attached.
- i. Generate plan communicating all proposed IT projects and projected associated costs for the upcoming year and five years with Village Manager, Assistant Village Manager, Finance Director, and appropriate department head(s) by June 1 of each year. Make changes in the asset list to reflect changes once approved by the Village Manager.
- j. Review the proposed annual budget to assure all IT approved projects are included.
- k. Present best IT practices in the industry when proposing budget and capital expenses to proactively address IT related security and performance concerns.

3. **Duration.**

This Agreement will become effective January 1, 2023 through December 31, 2025, with an automatic renewal for two additional years, unless mutually

agreed upon otherwise by the parties. This Agreement may be cancelled on ninety (90) days written notice of either party.

4. **Use of Village Name**

It is understood and agreed that the name of the Village and the municipal location may not be used by the Service Provider or its agents in any promotional materials without prior approval of the Village.

5. **Independent Contractor.**

It is understood and agreed that the Service Provider is an independent contractor for the performance of all services described within this Agreement.

6. **Assignment.**

This Agreement and interests hereunder are not to be assigned.

7. **Liability.**

The Village represents that it does not carry any insurance covering liability of its independent contractors, including the Service Provider. Service Provider is solely responsible for obtaining any insurance coverage that may be necessary to carry out its business, including workers compensation coverage and/or liability coverage as dictated by state statute. Nothing in this agreement is intended to abrogate the immunities or limitations of liability as enumerated in Wis. Stat. §893.80 that may be asserted by either the Village or the Service Provider.

8. **Wisconsin Law.**

This Agreement shall be governed by and construed with the laws of the State of Wisconsin.

9. **Complete Agreement.**

This Agreement represents the entire of listing of the terms between the parties. This Agreement may be modified only in writing by an amendment signed by both parties.

10. **Endorsement.**

By endorsing this Agreement both the Service Provider and the Village indicate that each has the authority to bind to the terms of this Contract.

Village of Shorewood

Village of Bayside

Rebecca Ewald, Village Manager

Andrew Pederson, Village Manager

Date



APPLICATION FOR SPECIAL EXCEPTION TO ZONING CODE REQUIREMENTS

The Board of Appeals, pursuant to Wis. Stats. 62.23(7)(e), and, Section 125-57(e) of the Zoning Ordinance, and after appropriate notice and hearing, may, with regard to any requirement imposed by the Zoning Ordinance, or any other section of the Municipal Code which specifically allows for special exceptions, recommend a special exception to the Village Board for approval. Notice of application for special exception shall be provided to all property owners adjoining or abutting the property proposed for a special exception. Denials of special exceptions shall not be appeal able to the Village Board.

- 1. State the section of the Village of Bayside Municipal Code for which you are requesting a special exception:.

104-125C

- 2. Give a brief description of what you want to do and why.

Install a black 4 foot high Aluminum fence in backyard to act as a dog containment area.

- 3. State why compliance with Municipal Code is unreasonably burdensome or negatively impacts the use of the property.

The municipal code is unreasonably burdensome because leaving 2% of our backyard unfenced hurts the flow and function of the space. It hinders us from enjoying our space as it is intended, creating a boundary to its

- 4. State how the Special Exception requested, including any proposed restrictions, will be consistent with the existing character of the neighborhood; will not effectively undermine the application or enforcement of the Code to other properties; and will be in harmony with the purpose and intent of the Code.

We are installing a 4 foot aluminum fence. It aligns with the aesthetic of our neighborhood and when we install it, it will actually open our yard up to our neighbors because we will remove arborvitae trees that line our backyard.

Applicant Printed Name

Applicant Signature

Date

Derreck Rose

[Handwritten Signature]

8/28/22

08/31/2022

Attention:
Village of Bayside, WI
Architecture Review Committee

<p>PROJECT/SITE OWNER: Katie Where Rose & Derreck Rose</p> <p>PROJECT ADDRESS: 824 E Hermitage</p>	<p>PROJECT SUMMARY: New four-foot aluminum open design fence 286 lineal feet</p>
---	--

I have reviewed the proposed new fence for compliance with the Village’s ordinances and have determined the following for consideration

1. Current fence ordinance 104-125 (C) does not allow fences to exceed 50% of the perimeter of the property. The perimeter of the property is approximately 546 feet.
2. The total linear footage of fencing is 286 feet.
3. **This is 52.38% of the perimeter of the property. This does not comply with the ordinance.**
4. The height of the fence is 4 feet open design, which is compliant with the ordinance.
5. **A current survey was not provided.**
6. Pictures were included for their neighboring fences
7. The board always considers matching fences with neighboring fences.

VILLAGE CODE REVIEW

Supporting documentation or testimony must be provide at the meeting to verify code compliance with the above observations in red.

Dave Hendrix
SAFEbuilt
Wisconsin Operations Manager

Project Proposal

Date 7/15/2022

Property Address 824 E. Hermitage Rd

Zoning District _____

Proposed Project Details (type of work, size, materials, location, etc.):

286 linear feet Aluminum 4' high fence in the back yard.

<ul style="list-style-type: none"> <input type="checkbox"/> ARC Agenda Date: <input type="checkbox"/> Parcel Number: <input type="checkbox"/> Color photographs showing project location, elevations, and surround views. <input type="checkbox"/> Two (2) complete digital sets of building plans (including elevations and grading). <input type="checkbox"/> Samples or brochures showing materials, colors, and designs. <input type="checkbox"/> Survey or Milwaukee County Land Information Officer Aerial <p>PERMITS:</p> <table style="width: 100%; border-collapse: collapse;"> <thead> <tr> <th style="text-align: left;">Y</th> <th style="text-align: left;">N</th> <th style="text-align: left;">Payment</th> <th></th> </tr> </thead> <tbody> <tr><td><input type="checkbox"/></td><td><input type="checkbox"/></td><td><input type="checkbox"/></td><td>Building</td></tr> <tr><td><input type="checkbox"/></td><td><input type="checkbox"/></td><td><input type="checkbox"/></td><td>Electrical</td></tr> <tr><td><input type="checkbox"/></td><td><input type="checkbox"/></td><td><input type="checkbox"/></td><td>Plumbing</td></tr> <tr><td><input type="checkbox"/></td><td><input type="checkbox"/></td><td><input type="checkbox"/></td><td>HVAC</td></tr> <tr><td><input type="checkbox"/></td><td><input type="checkbox"/></td><td><input type="checkbox"/></td><td>Fill</td></tr> <tr><td><input type="checkbox"/></td><td><input type="checkbox"/></td><td><input type="checkbox"/></td><td>Impervious Surface</td></tr> <tr><td><input type="checkbox"/></td><td><input type="checkbox"/></td><td><input type="checkbox"/></td><td>Dumpster</td></tr> <tr><td><input type="checkbox"/></td><td><input type="checkbox"/></td><td><input type="checkbox"/></td><td>ROW/Excavation</td></tr> <tr><td><input type="checkbox"/></td><td><input type="checkbox"/></td><td><input type="checkbox"/></td><td>Conditional Use</td></tr> <tr><td><input type="checkbox"/></td><td><input type="checkbox"/></td><td><input type="checkbox"/></td><td>Occupancy</td></tr> <tr><td><input type="checkbox"/></td><td><input type="checkbox"/></td><td><input type="checkbox"/></td><td>Special Exception/Variance</td></tr> <tr><td></td><td><input type="checkbox"/></td><td></td><td>ARC</td></tr> </tbody> </table>	Y	N	Payment		<input type="checkbox"/>	<input type="checkbox"/>	<input type="checkbox"/>	Building	<input type="checkbox"/>	<input type="checkbox"/>	<input type="checkbox"/>	Electrical	<input type="checkbox"/>	<input type="checkbox"/>	<input type="checkbox"/>	Plumbing	<input type="checkbox"/>	<input type="checkbox"/>	<input type="checkbox"/>	HVAC	<input type="checkbox"/>	<input type="checkbox"/>	<input type="checkbox"/>	Fill	<input type="checkbox"/>	<input type="checkbox"/>	<input type="checkbox"/>	Impervious Surface	<input type="checkbox"/>	<input type="checkbox"/>	<input type="checkbox"/>	Dumpster	<input type="checkbox"/>	<input type="checkbox"/>	<input type="checkbox"/>	ROW/Excavation	<input type="checkbox"/>	<input type="checkbox"/>	<input type="checkbox"/>	Conditional Use	<input type="checkbox"/>	<input type="checkbox"/>	<input type="checkbox"/>	Occupancy	<input type="checkbox"/>	<input type="checkbox"/>	<input type="checkbox"/>	Special Exception/Variance		<input type="checkbox"/>		ARC	<ul style="list-style-type: none"> <input type="checkbox"/> Accessory Structures/Generators <input type="checkbox"/> Additions/Remodel <input type="checkbox"/> Commercial Signage <input type="checkbox"/> Decks/Patios <input checked="" type="checkbox"/> Fence <input type="checkbox"/> Fire Pits <input type="checkbox"/> Landscaping requiring Impervious Surface/Fill/Excavation Permit <input type="checkbox"/> New Construction <input type="checkbox"/> Play Structures <input type="checkbox"/> Recreational Facilities/Courts <input type="checkbox"/> Roofs <input type="checkbox"/> Solar Panels/Skylights <input type="checkbox"/> Swimming Pools <input type="checkbox"/> Windows/Doors - change exceeds 25% of opening <input type="checkbox"/> Other
Y	N	Payment																																																			
<input type="checkbox"/>	<input type="checkbox"/>	<input type="checkbox"/>	Building																																																		
<input type="checkbox"/>	<input type="checkbox"/>	<input type="checkbox"/>	Electrical																																																		
<input type="checkbox"/>	<input type="checkbox"/>	<input type="checkbox"/>	Plumbing																																																		
<input type="checkbox"/>	<input type="checkbox"/>	<input type="checkbox"/>	HVAC																																																		
<input type="checkbox"/>	<input type="checkbox"/>	<input type="checkbox"/>	Fill																																																		
<input type="checkbox"/>	<input type="checkbox"/>	<input type="checkbox"/>	Impervious Surface																																																		
<input type="checkbox"/>	<input type="checkbox"/>	<input type="checkbox"/>	Dumpster																																																		
<input type="checkbox"/>	<input type="checkbox"/>	<input type="checkbox"/>	ROW/Excavation																																																		
<input type="checkbox"/>	<input type="checkbox"/>	<input type="checkbox"/>	Conditional Use																																																		
<input type="checkbox"/>	<input type="checkbox"/>	<input type="checkbox"/>	Occupancy																																																		
<input type="checkbox"/>	<input type="checkbox"/>	<input type="checkbox"/>	Special Exception/Variance																																																		
	<input type="checkbox"/>		ARC																																																		



MILWAUKEE COUNTY INTERACTIVE MAPPING SERVICE



NAD_1983_2011_StatePlane_Wisconsin_South_FIPS_4803_Ft_1:282

©MCMALLIS

DISCLAIMER: This map is a user generated static output from the Milwaukee County Land Information Office Interactive Mapping Service website. The contents herein are for reference purposes only and may or may not be accurate, current or otherwise reliable. No liability is assumed for the data delineated herein either expressed or implied by Milwaukee County or its employees.
THIS MAP IS NOT TO BE USED FOR NAVIGATION

Notes

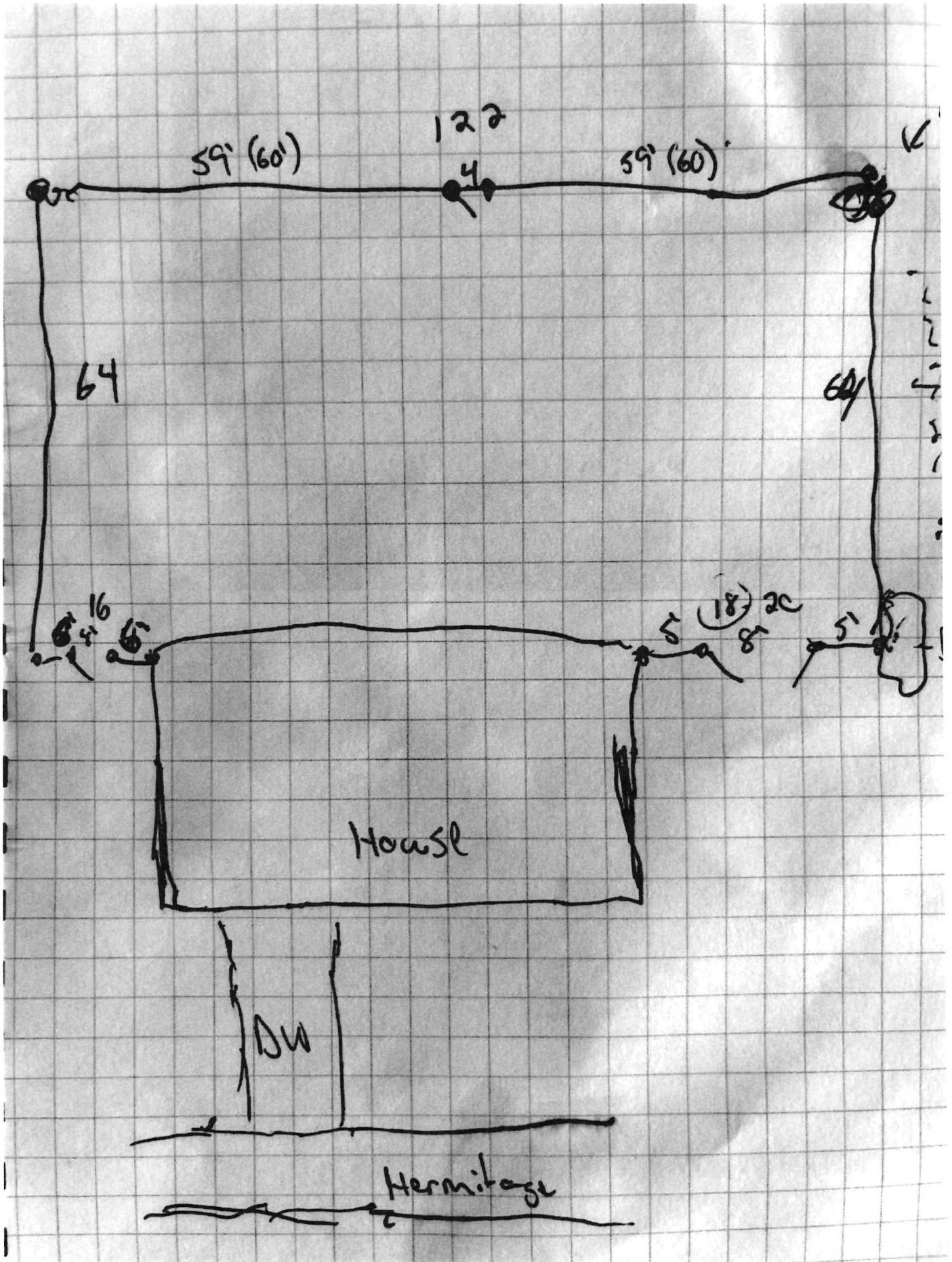









APPLICATION FOR SPECIAL EXCEPTION TO ZONING CODE REQUIREMENTS

The Board of Appeals, pursuant to Wis. Stats. 62.23(7)(e), and, Section 125-57(e) of the Zoning Ordinance, and after appropriate notice and hearing, may, with regard to any requirement imposed by the Zoning Ordinance, or any other section of the Municipal Code which specifically allows for special exceptions, recommend a special exception to the Village Board for approval. Notice of application for special exception shall be provided to all property owners adjoining or abutting the property proposed for a special exception. Denials of special exceptions shall not be appeal able to the Village Board.

- 1. State the section of the Village of Bayside Municipal Code for which you are requesting a special exception:.

See attached Exhibit A for answers to questions 1-4

- 2. Give a brief description of what you want to do and why.

- 3. State why compliance with Municipal Code is unreasonably burdensome or negatively impacts the use of the property.

- 4. State how the Special Exception requested, including any proposed restrictions, will be consistent with the existing character of the neighborhood; will not effectively undermine the application or enforcement of the Code to other properties; and will be in harmony with the purpose and intent of the Code.

Applicant Printed Name

Colin White

Applicant Signature

Date

8/31/2022

EXHIBIT A

1400 E Bay Point Road Special Exception Application

August 25th, 2022

Responses to questions 1-4 found on *Application for Special Exception to the Zoning Requirements*

1. State the Section of the Village of Bayside Municipal Code that you are appealing.

The applicant is appealing Sec 104-125 (j) *Fence Height*: “Fences constructed within the front yard of a home shall not exceed three feet in height. Ornamental posts protruding less than one foot above the measured average height of a fence may be permitted provided they are at least six feet apart, or are otherwise granted exception for closer proximity by the architectural review committee (which exception shall be subject to a two-thirds vote). In all other cases, fences shall be measured to their highest point (including posts) in determining compliance with height restrictions.”

2. Give a brief description of what you want to do and why.

The applicant is seeking a Special Exception that would allow them to construct two masonry lamp posts and attached, curved masonry landscape walls that exceed the height limits stated in the Code. They would be located near the point where a driveway shared with one neighbor divides and enters their private property.

The lamp posts would be approximately 6'-8" tall by 2'-4" square, while the attached walls would be approximately 5'-8" tall where they connect to the lamp posts and step down to approximately 4'-8" tall at the halfway point of their 11'-0" lengths. (See attached Exhibits of plans, elevations, and 3D model views)

The lamp posts and the long faces of the landscape walls will be located more than 17'-0" from the nearest (south) property line, while the narrow end of the western wall will be almost 11'-0" from the west property line at its closest point. The lamp posts and landscape walls will be complemented by planting beds between their “public-facing” sides and the nearest property lines.

3. State why compliance with the Municipal code is unreasonably burdensome or negatively impacting upon the use of this property.

Compliance with the Municipal Code is unreasonably burdensome or negatively impacting for the following reasons:

- a. While the Village of Bayside Municipal Code treats the proposed lamp posts and landscape walls as a fence, they are not intended to function as a fence in the common sense of the word. They will not visually or physically separate the Applicants' property from neighboring properties in any significant way, nor impede any critical sightlines from the neighboring properties to desirable lake views. Given

that the combined 26'-8" length of the two lamp posts and attached walls equates to roughly 1.3% of the overall 2,066'+/- length of the property's perimeter, they will in no way serve as a practical deterrent to accessing the Applicants' property.

- b. Complying with the 3'-0" height limit of the fence ordinance and the effective 4'-0" height limit of the ornamental post portion of the fence ordinance will negatively affect the aesthetics and proportions of the proposed lamp posts and landscape walls as stand-alone, semi-monumental entities, especially with anything taller than ground cover planted in the adjacent landscape beds.
- c. Complying with the stated fence height limits will also cause the lamp posts and landscape walls to be out of scale with the house and garage they are intended to complement.

4. State how the Special Exception requested, including any proposed restrictions, will be consistent with the existing character of the neighborhood; will not effectively undermine the application or enforcement of the Code to other properties; and will be in harmony with the purpose and intent of the Code.

Allowing the Applicants to exceed the maximum fence and ornamental post heights stated in the Codes will be consistent with the existing character of the neighborhood in the following ways:

- a. The neighborhood in which the Applicants' property is located features a handful of estate-type properties of comparable size and scale to the Applicants'. Based on a windshield survey taken from public roads of those similar properties, not more than 5 feature gate/lamp posts and walls that are visible from the public roads and are similar in size to those the Applicants are seeking to build.

It should be noted that the Applicants' proposed lamp posts and landscape walls are not visible from the adjacent public road, and will only be of concern to their adjacent neighbors. Those neighbors have indicated their support of the Applicants' request to build the proposed lamp posts and landscape walls.

- b. *The* defining feature of the neighborhood in which the Applicants' property is located are the beloved monumental Donges Bay Lion Walls at the intersection of Lake Drive and Fairy Chasm Road.

Allowing the Applicants to exceed the maximum fence and ornamental post heights stated in the Codes will not effectively undermine the application or enforcement of the Code to other properties for the following reasons:

- a. The number of properties upon which such lamp posts and landscape walls would fit is limited to a small percentage of all the properties in the Village. Of those few properties, many already have similar landscape features.
- b. The considerable cost of constructing lamp posts and landscape walls like the Applicants seek to build renders it highly unlikely that many home owners in the village will be interested in adding similar features of similar scale to their properties.

Allowing the Applicants to exceed the maximum fence and ornamental post heights stated in the Codes will be in harmony with the purpose and intent of the Code for the following reasons:

- a. As stated in the Preamble to Sec. 104-125 the general purpose of the fence code is to encourage the maintenance of a sense of open space that makes the village a desirable place to live. As noted above, the proposed lamp posts and landscape walls cover only about 1.3% of the Applicants' property perimeter, a percentage that is well short of the 50% allowed in the Code. Based on that, it can be argued that these proposed landscape features are in more harmony with the Fence Codes general purpose, despite being somewhat taller than allowed in that Code, than a fence at the maximum allowed length that meets the Code height limit would be.
- b. If it can be assumed that one of the overall goals of Chapter 104 in the Village Municipal Code is to encourage an aesthetically harmonious community, it follows that well-proportioned landscape features such as the one being proposed by the Applicants are in line with that goal, whereas poorly-proportioned landscape features that would result from complying with the Codes' height restrictions would be opposition to that overall goal.

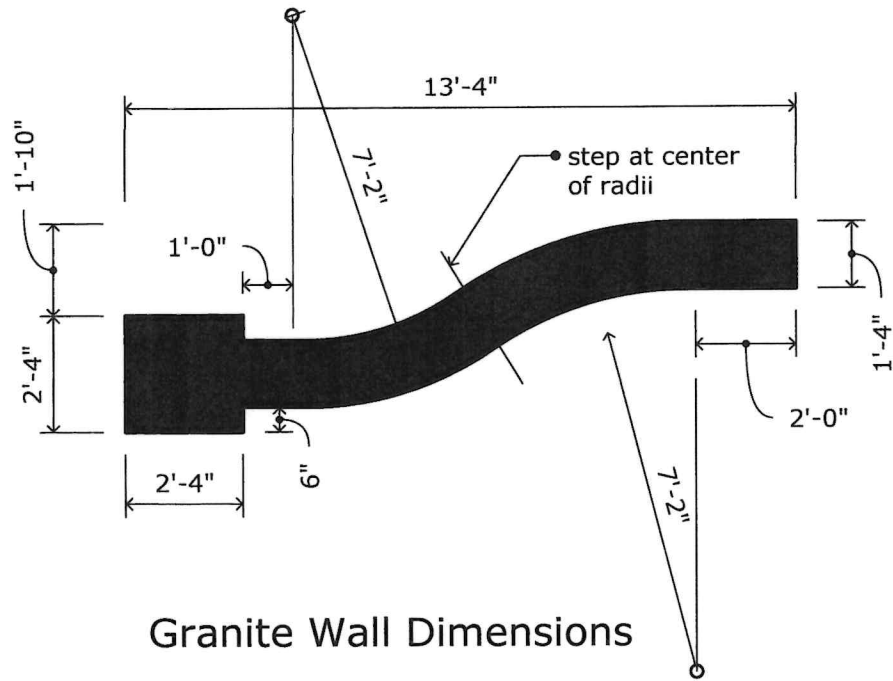

Granite Wall Dimensions

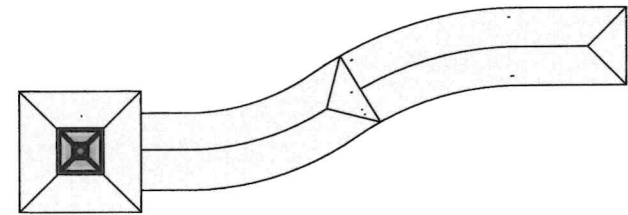

Limestone Cap

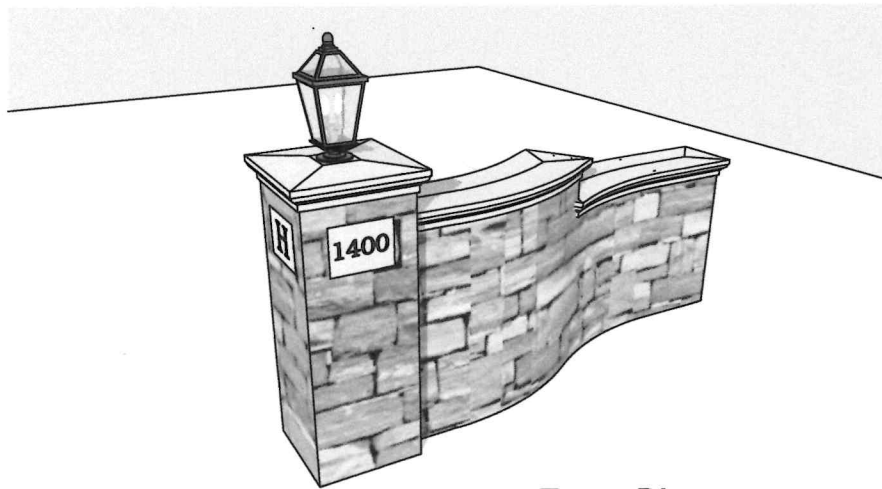

East Pier

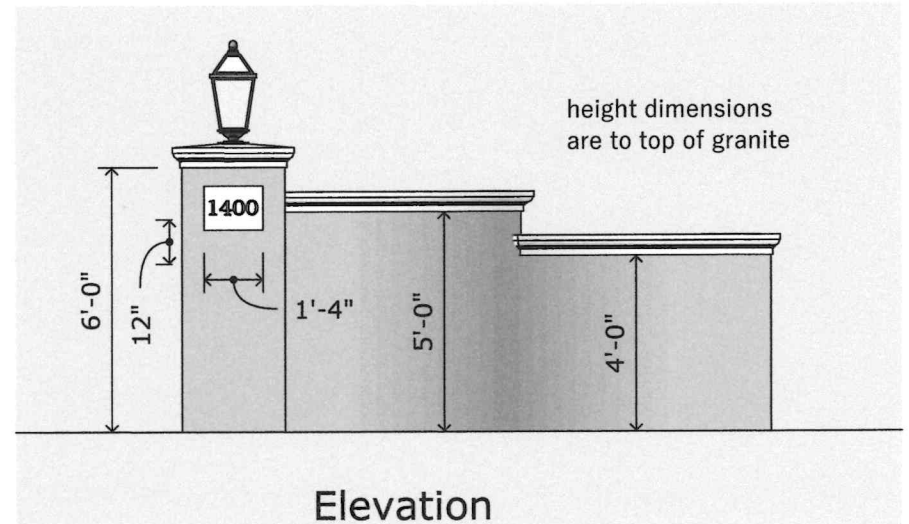

Elevation

1400 BAY POINT LAMP POSTS AND WALLS
EXHIBIT B1

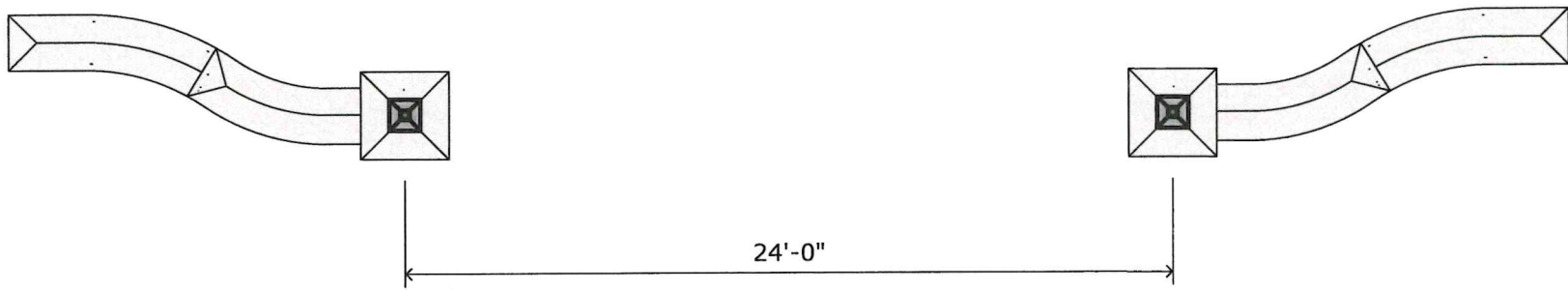

Plan

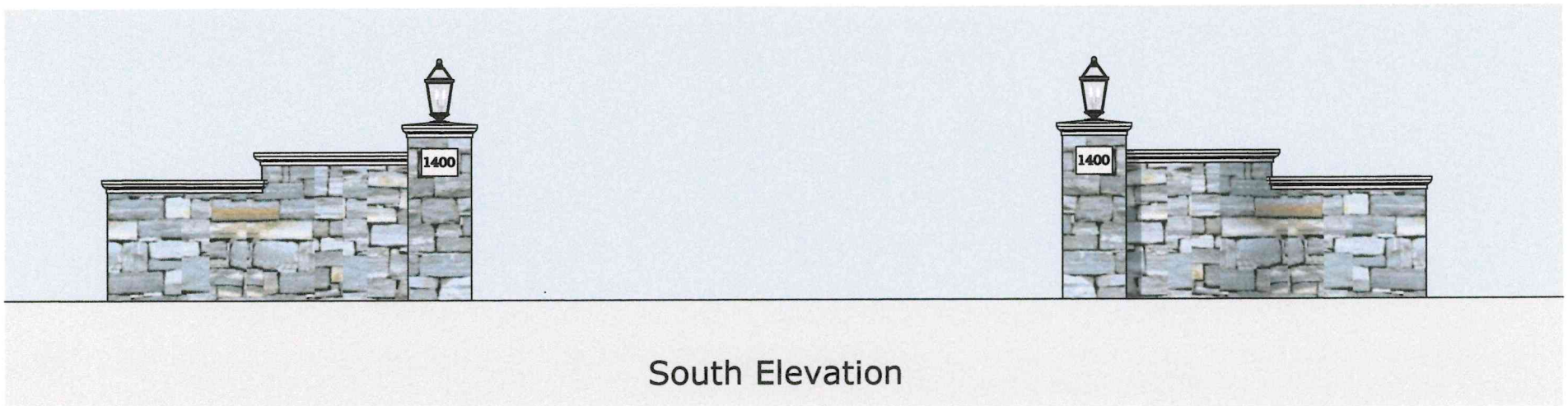

South Elevation

1400 BAY POINT LAMP POSTS AND WALLS
EXHIBIT B1

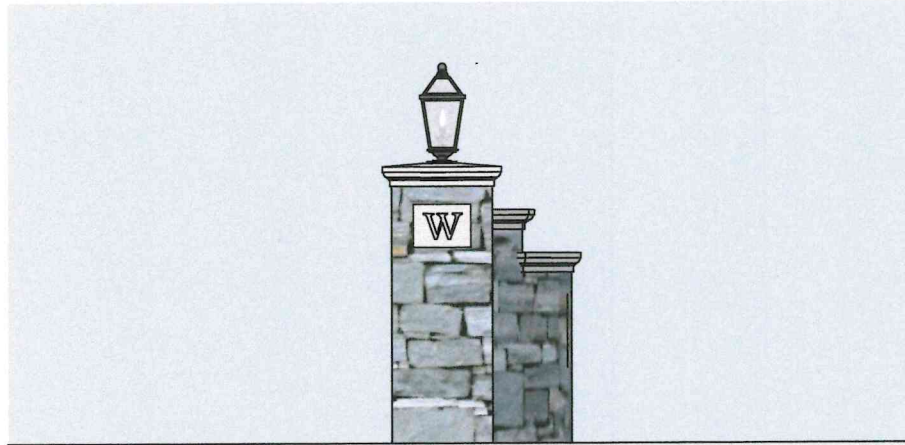

West Pier Elevation

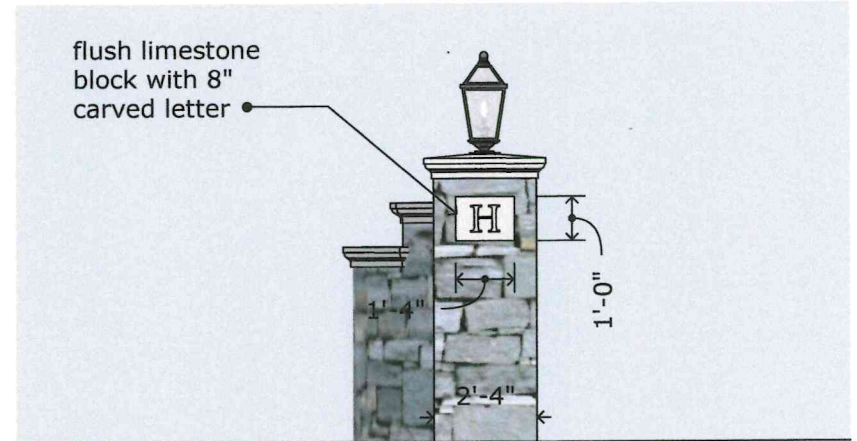

East Pier Elevation

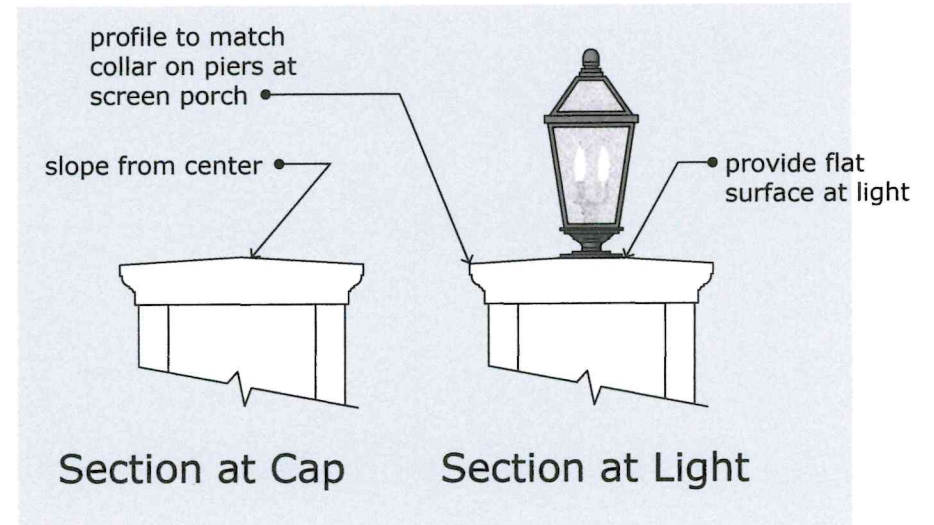
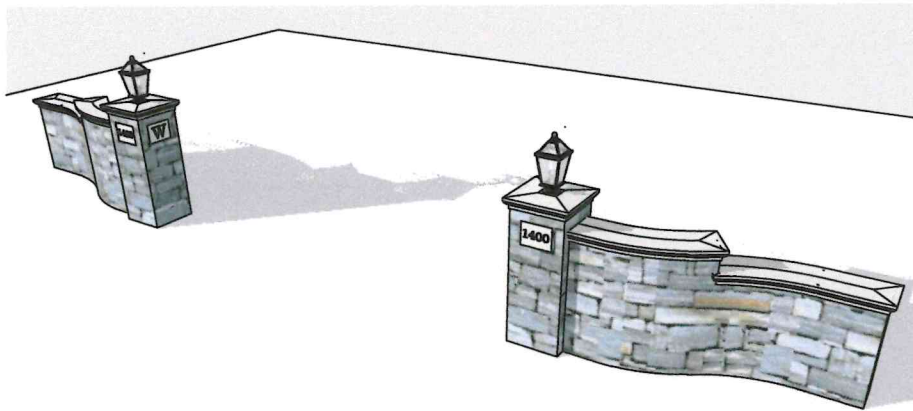

Section at Cap

Section at Light

1400 BAY POINT LAMP POSTS AND WALLS
EXHIBIT B1

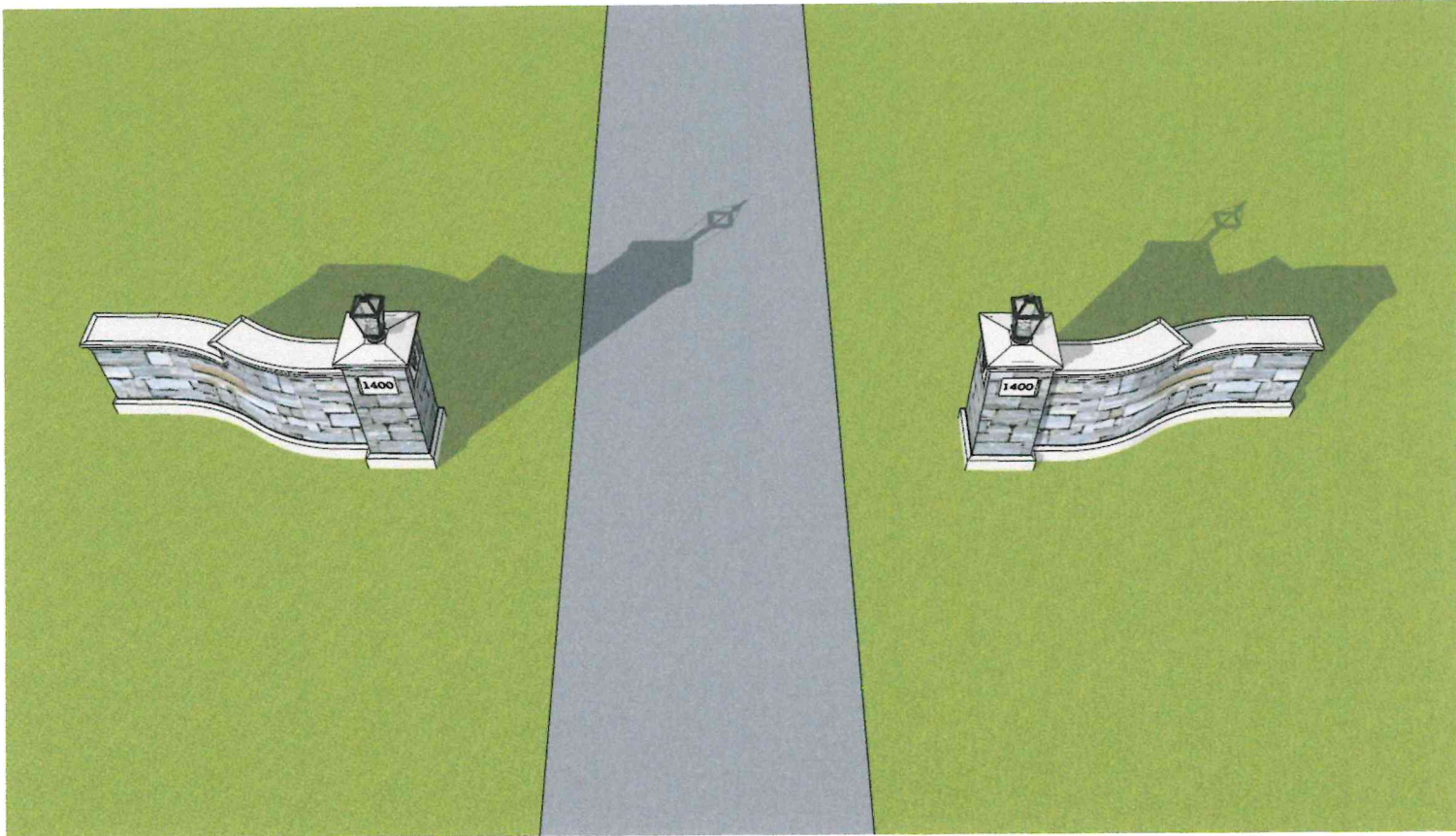

Close-up Aerial View From South

1400 E BAY POINT LAMP POSTS AND WALLS
EXHIBIT B2

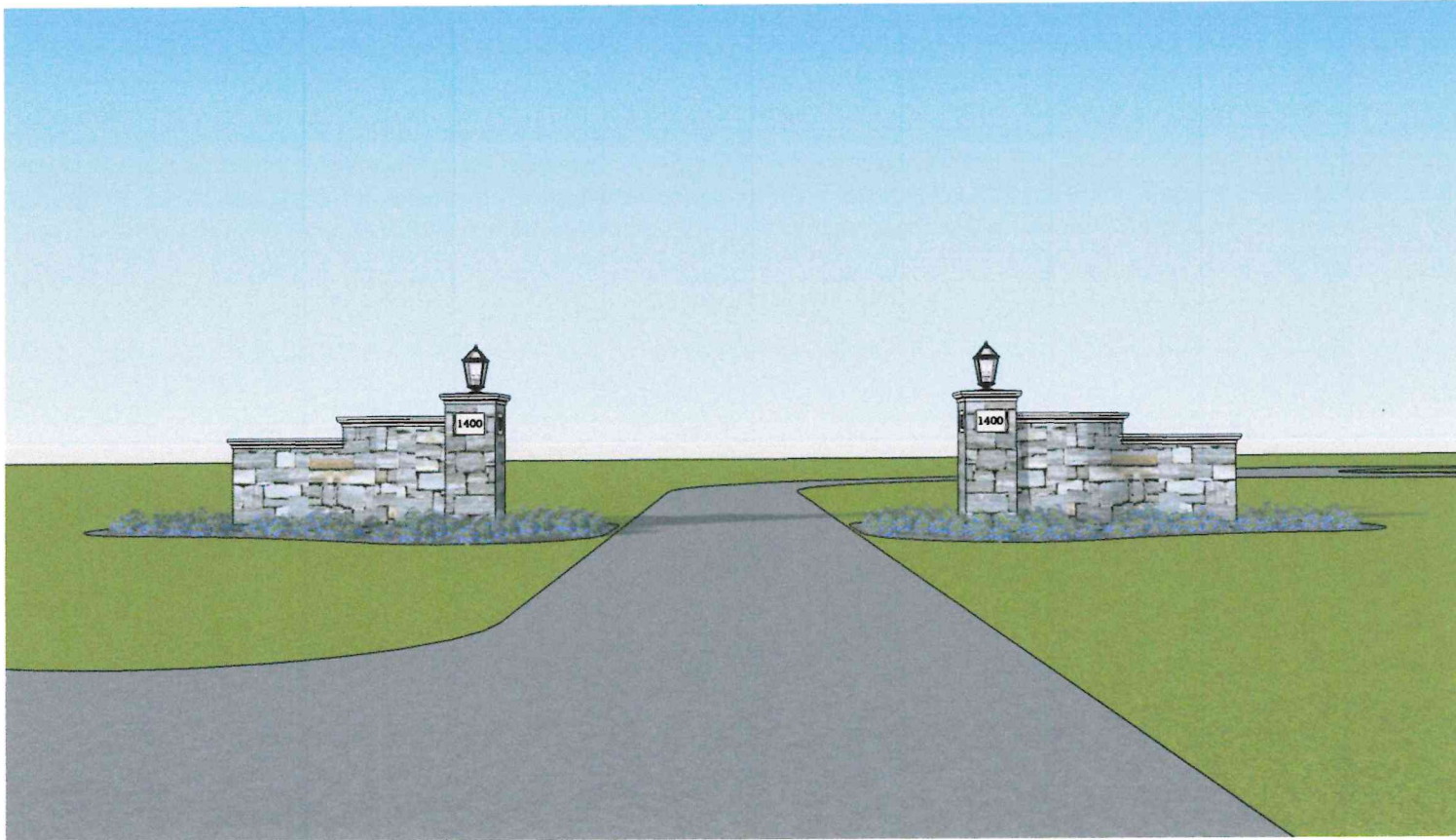

Close-up Eye-Level View Fom South

1400 E BAY POINT LAMP POSTS AND WALLS
EXHIBIT B2

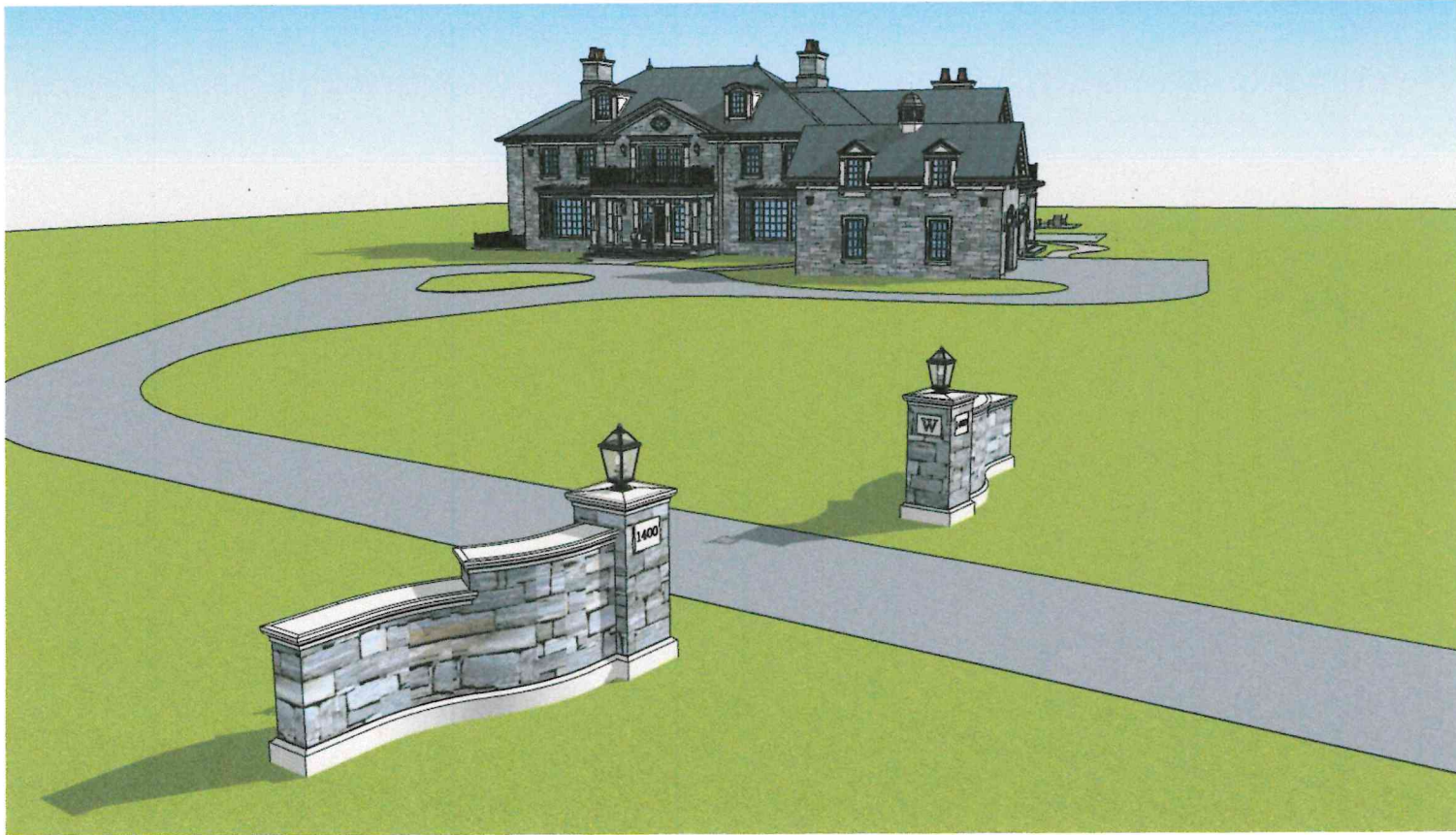

Wide-Angle View From Southwest

1400 E BAY POINT LAMP POSTS AND WALLS
EXHIBIT B2

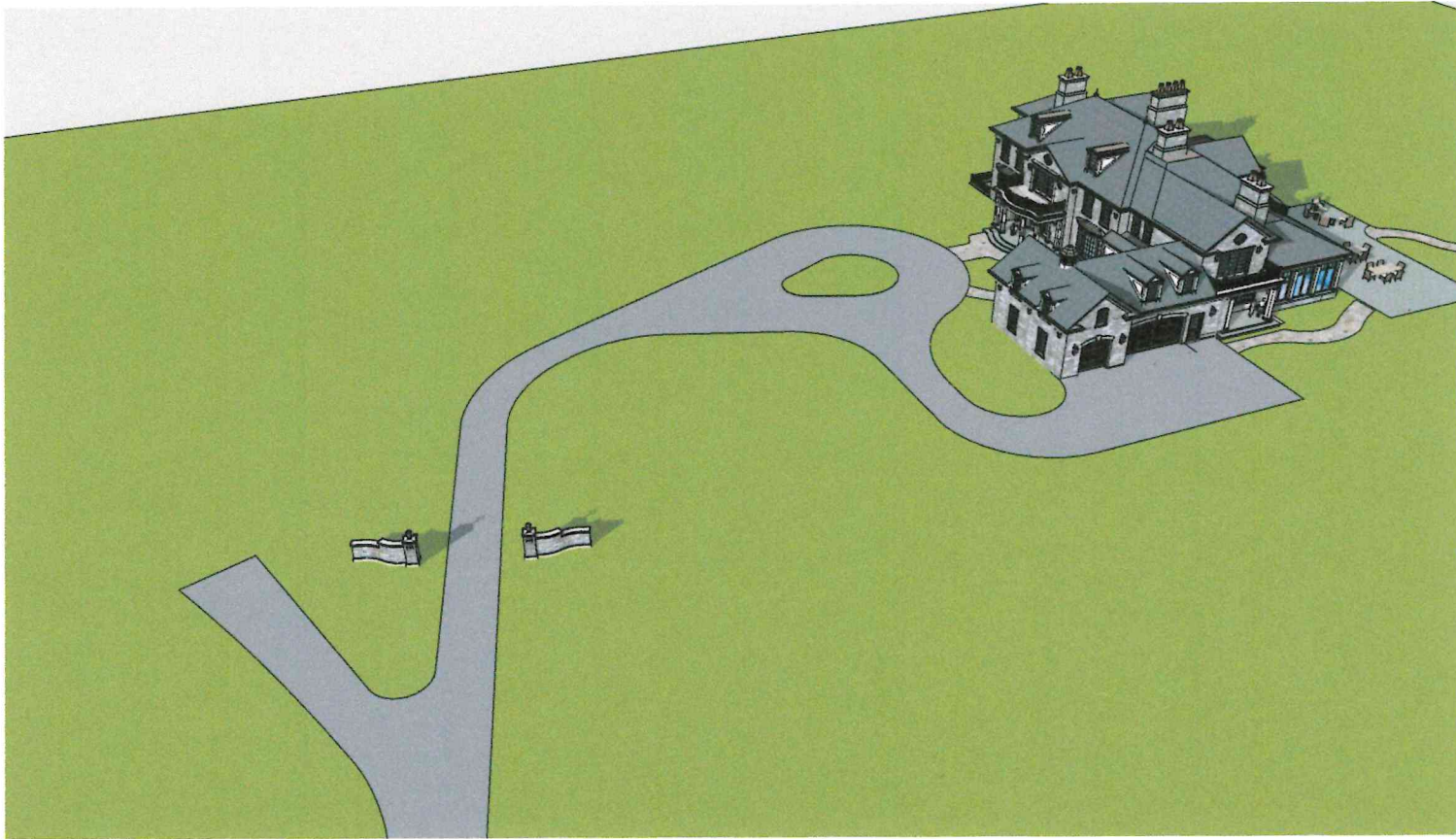

Wide-Angle Aerial View From South

1400 E BAY POINT LAMP POSTS AND WALLS
EXHIBIT B2



APPLICATION FOR SPECIAL EXCEPTION TO ZONING CODE REQUIREMENTS

The Board of Appeals, pursuant to Wis. Stats. 62.23(7)(e), and, Section 125-57(e) of the Zoning Ordinance, and after appropriate notice and hearing, may, with regard to any requirement imposed by the Zoning Ordinance, or any other section of the Municipal Code which specifically allows for special exceptions, recommend a special exception to the Village Board for approval. Notice of application for special exception shall be provided to all property owners adjoining or abutting the property proposed for a special exception. Denials of special exceptions shall not be appeal able to the Village Board.

1. State the section of the Village of Bayside Municipal Code for which you are requesting a special exception:.

Sec 104-125(K)

2. Give a brief description of what you want to do and why.

BUILD AN BACK YARD EXTERIOR FENCE WOOD WITH LATTICE TOP FOR PRIVACY FROM DEJAYING PROPERTY.

3. State why compliance with Municipal Code is unreasonably burdensome or negatively impacts the use of the property.

THE EASTERN PROPERTY WOULD NOT BE HIDDEN, NOR WOULD IT BE FLUID IF IT WERE TO STAND ALONE.

4. State how the Special Exception requested, including any proposed restrictions, will be consistent with the existing character of the neighborhood; will not effectively undermine the application or enforcement of the Code to other properties; and will be in harmony with the purpose and intent of the Code.

BUCK THORN AND OTHER FENCES ARE IN AREA DOGS WANDER INTO BACK YARD. DEJAYING PROPERTY HAS RACOONS.

Applicant Printed Name

RATHEEN Thomas Rozen

Applicant Signature

Thomas E. Rozen

Date

7-14-22

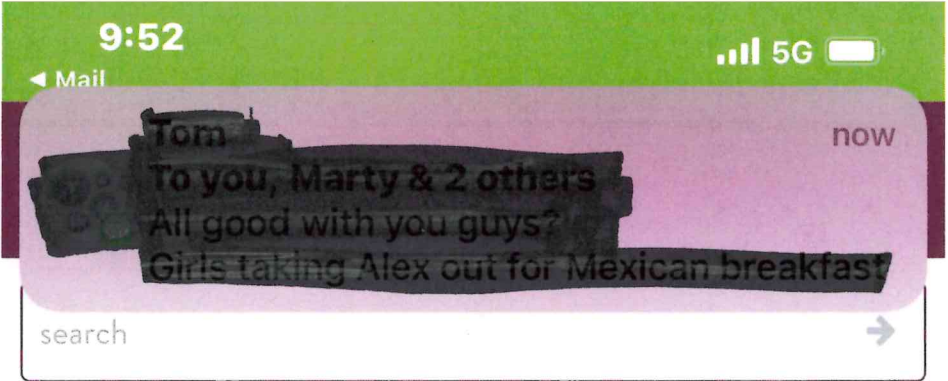

PREASSEMBLED FENCE PANELS

Home > Products > Wood Fence > Preassembled Fence Panels > Semi-Privacy Fence Panels

DOUBLE CLICK IMAGE TO ZOOM. [Click here to open in a new window.](#)

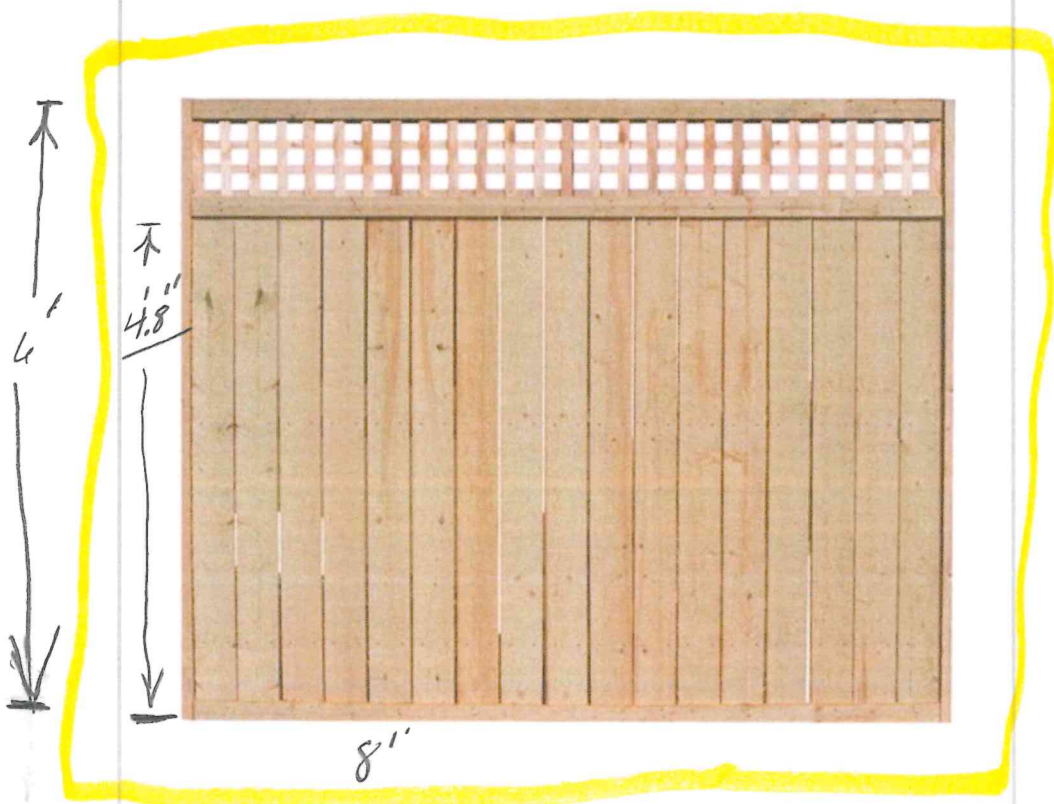

NEW AND REPLACEMENT FENCE - THIS FENCE [redacted]





ON BACK



Services Offered
 Commercial Site Development
 Subdivision Design and Platting
 Planning
 Streets and Highway Design
 Drainage Studies
 Water Distribution Systems
 Sewer Collection Systems
 Construction Surveying and Stake out Services



Nienow Engineering Assoc.
 Consulting Engineers and Surveyors
 5555 N. Port Washington Road
 Milwaukee, WI 53217
 414-963-4022
 (Fax) 414-963-4028

PROJ. NO. 95294
 W95294S1

PLAT OF SURVEY

PREPARED FOR: **PENN**

LEGAL DESCRIPTION:
 LOT 3, BLOCK 5, BAYSIDE, BEING A SUBDIVISION OF 39 ACRES LOCATED IN THE SOUTHEAST 1/4 OF SECTION 4,
 TOWN 8 NORTH, RANGE 22 EAST, MILWAUKEE COUNTY, WISCONSIN.

CURVE DATA

RADIUS	LENGTH	CHORD	BEARING	DELTA
3994.88'	112.75'	112.75'	N03°35'42"W	01°37'02"

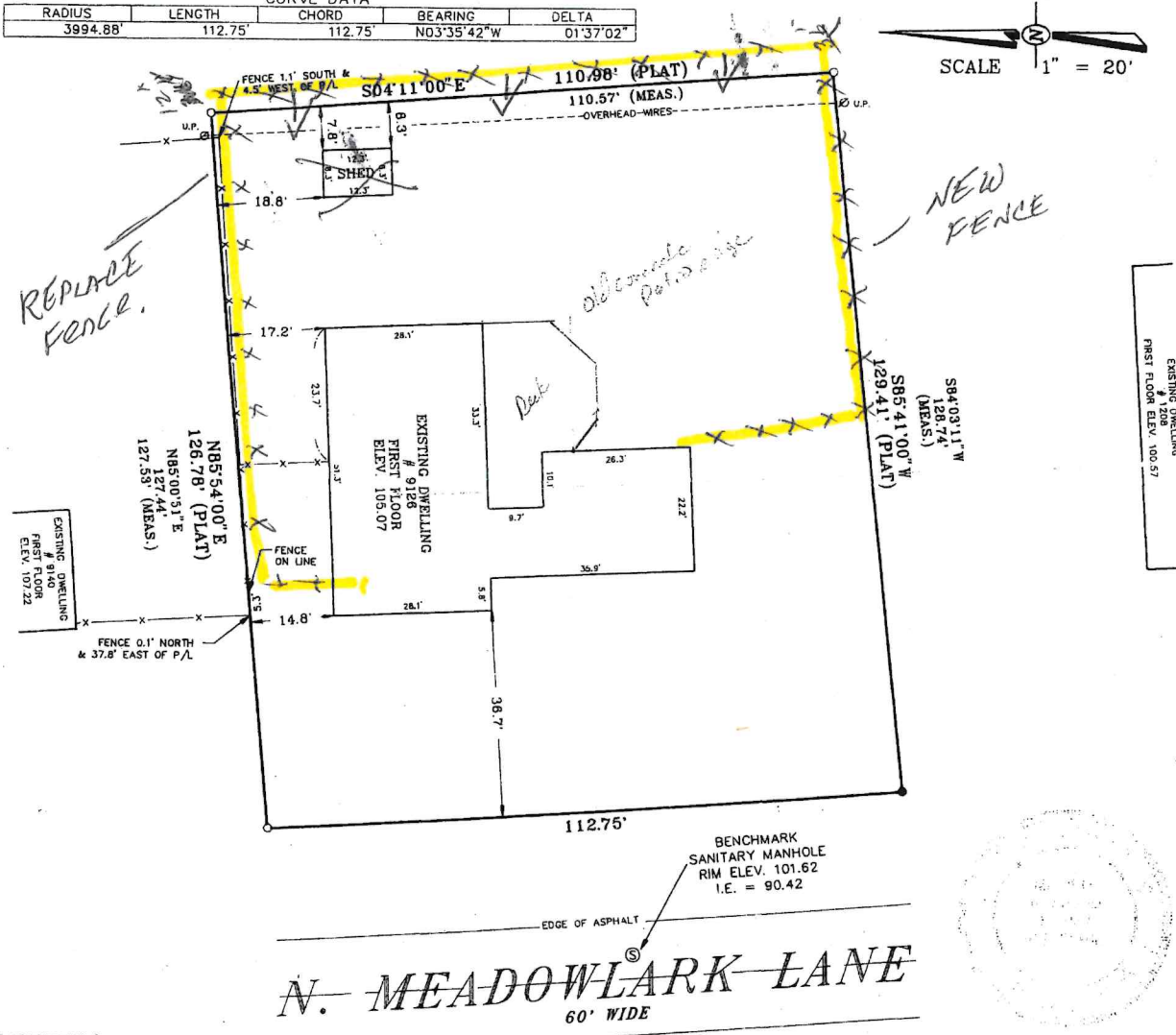
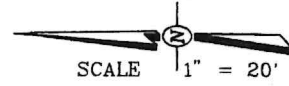

N. MEADOWLARK LANE
 60' WIDE

STATE OF WISCONSIN)
 MILWAUKEE COUNTY)

I hereby certify that I have surveyed the above described property and the above map is a true representation thereof and show the site and location of the property, its exterior boundaries, the location of all visible structures and dimensions of all principal buildings thereon, boundary fences, apparent easements, roadway and visible encroachments, if any.

This survey is made for the present owners of the property, and also those who purchase, mortgage, or guarantee, the title thereto within (1) year from date hereof.

Dated at MILWAUKEE, WI this 23RD day of JUNE, 1995.

Recertified _____
M.D. Pungol
 Surveyor

- LEGEND -**
- - DENOTES IRON PIPE - SET
 - - DENOTES IRON PIPE - FOUND
 - X-X- DENOTES WIRE FENCE
 - ⊙ U.P. - DENOTES UTILITY POLE
 - Ⓢ - DENOTES SANITARY MANHOLE

APPROVED
 VILLAGE OF BAYVIEW
 BUILDING COMMITTEE

DATE _____

*Officer
 Sue Strick
 Jim Moore
 Michael...*

7-19-22

- BAYSIDE TRUSTEE'S -

MY NAME IS THOMAS/KATHLEEN ROOZEN
9126 N. MEADOWLARK LN. LONG TIME
(22) YRS RESIDENTS OF THE VILLAGE.

FOR OVER 10 YEARS WE HAVE ENDURED
BULK THORN, DECAYING PROPERTY
TO OUR EAST (NOTE PICTURE)
NOW INFESTED. WE WOULD NOW
LIKE TO ENJOY OUR RETIREMENT
GARDENING, ENTERTAINING AND
WITH FAMILY IN PRIVACY AND
BEAUTY OF OUR HOME. WE CHOSE
A LATHICE TOP FENCE TO HAVE
CLIMBING VINES AS WELL AS
NOT HAVE A SOLID FENCE STRUCTURE.

ALL THREE OF MY NEIGHBORS
INCLUDING DAVID ROLL (EAST)
(DECAYING HOME) AGREED TO THE
FENCE. I HAVE SAMPLE IN PACKET
AND IN MY BACKYARD. LETTERS

THEY HAVE ALL HAVE SIGNED
ARE IN THE INFORMATION AS
WELL. - MR ROSENFELD AND MR
WALDNY BOTH KNOW ME AND
KNOW MY INTEREST IN OUR
COMMUNITY. IT IS OUR HOPE
THE VILLAGE WILL APPROVE
MY REQUEST.

KIND REGARDS,

Tom Rozen & KATHEN ROZEN-

7-19-22

To whom this may concern:

Tom and Katie Roozen, my neighbors, have informed me about their plans to construct a 6' privacy fence around the north, east and south elevations around the back of their home. I agree with this plan and have no objections.

Neighbor Name:

ANDREW + JAMIE CARLSON
Andrew D Carlson Jamie Ah

Address:

1208 E. MANOR CIR

Date:

July 11, 2022

To whom this may concern:

Tom and Katie Roozen, my neighbors, have informed me about their plans to construct a 6' privacy fence around the north, east and south elevations around the back of their home. I agree with this plan and have no objections.

Neighbor Name: DAVID L. ROLL

Address: 9121 N. TENNYSON DR.
MILWAUKEE, WI 53217

Date: 7/12/22

David L. Roll

To whom this may concern:

Tom and Katie Roozen, my neighbors, have informed me about their plans to construct a 6' privacy fence around the north, east and south elevations around the back of their home. I agree with this plan and have no objections.

Neighbor Name: Mike Gielow & Renee Johnson

Address: 9140 N Meadowlark Ln
Bayside 53217

Date: 07/16/2022

A handwritten signature in black ink, appearing to read "Mike Gielow". The signature is stylized with large, sweeping loops and is positioned below the date.

NORTH SHORE LIBRARY - STATISTICS FOR JULY 2022

		July	YTD
Library Activity	Checkouts	17314	110433
	Checkins	13173	82106
	Patron Count	7637	44849
Patron Activity by Community	Bayside	2299	18931
	Fox Point	5016	40167
	Glendale	6964	98671
	River Hills	725	4087
Curbside		50	
Study Room(s) Usage	Uses per month	99	573
	Hours per month	172	805
Community Room Usage	Library program	17	172
	Outside group	6	50
	Total uses	23	222
Community Room Hours	Library program	23	212
	Outside group	9.5	108.75
	Total hours	32.5	320.75
Kanopy		116	1871
Overdrive	Audio	1644	10889
	E-book	2187	15041
	Magazine	516	3627
	Total	4347	29557
Filled holds		3901	29008
New patrons		76	442
New items		569	3898
Wifi access		29152	176726
Website visits		5475	

NORTH SHORE LIBRARY - STATISTICS FOR AUGUST 2022

		July	August	YTD
Library Activity	Checkouts	17314	17615	124456
	Checkins	13173	14640	100904
	Patron Count	7637	7626	20351
Patron Activity by Community	Bayside	2299	2396	21327
	Fox Point	5016	5028	45195
	Glendale	6964	7433	106104
	River Hills	725	761	4848
Curbside		50	57	
Study Room(s) Usage	Uses per month	99	103	676
	Hours per month	172	176.92	981.92
Community Room Usage	Library program	17	11	183
	Outside group	6	2	52
	Total uses	23	13	235
Community Room Hours	Library program	23	15.5	227.5
	Outside group	9.5	6	114.75
	Total hours	32.5	21.5	342.25
Kanopy		116	172	1942
Overdrive	Audio	1644	1701	12390
	E-book	2187	2117	17158
	Magazine	516	598	4225
	Total	4347	4417	33782 (includes 9 video)
Filled holds		3901	4520	32794
New patrons		76	67	495
New items		569	462	4292
Wifi access		29152	26401	203127
Website visits		4504	4179	32374