

SECTION 4.1 BUILDING TYPES ESTABLISHED

Because of the established architectural vernacular of the City of Belmont in a wide-variety of common building types, this Code has established regulations specific to these typologies. These building types do not favor one specific architectural style over another, though certain styles are not appropriate for the types presented in this Code. Design regulations are not intended to promote the replication of the existing built form of Belmont, but to allow imaginative design that is respectful of its neighborhood.

The rich, architectural vocabulary of the City presents a wide variety of development opportunities using traditional forms while avoiding any perception of monotony. Buildings that are stylized in an attempt to use the building itself as advertising shall be discouraged, particularly where the proposed architecture is the result of a “corporate” or franchise style. The guidelines in this Chapter are intended to attach the same or greater level of importance to the overall building design as is placed on the use contained within. Buildings are expected to be added to the City of Belmont as long-term additions to the architectural vibrancy of the community. Unless otherwise noted, all buildings shall meet the following:

1. All buildings shall share a frontage line with a street or civic open space (Exception: Buildings in the H-C, BC-D, and IC-D districts that are interior to a site which have buildings that otherwise meet the frontage requirements such as significant outparcel buildings are not subject to this requirement).
2. Principal building entrances shall be from the fronting street.
3. All buildings, except accessory structures, shall have a main, useable entrance opening onto a street or square from the front facade. On a corner lot, the principal entrance in both design and function should be from the primary pedestrian street. Pedestrian connections from the principal entrance of the building to sidewalks on adjoining streets and parking lots shall be built. (Exception: Flex Commercial buildings may be accessed from entries located in the front half of the building)
4. Important street vistas (such as along City gateways and primary pedestrian streets) should terminate in a focal point, such as a building or other architectural or natural feature.
5. Adjacent buildings housing similar type uses that are located within the same or similar zoning districts should relate in similarity of scale, height, architectural style, and configuration.
6. Windows, doors, columns, eaves, parapets, and other building components shall be proportional to the overall scale of the building. Windows shall be vertically proportioned wherever possible.
7. All visibly exposed facades (exception: Single Family Homes and Duplexes) should have:
 - a) a recognizable base course consisting of, but not limited to thicker walls, ledges or sills; integrally textured materials such as stone or other masonry; integrally colored and patterned materials such as smooth finished stone or tile; lighter or darker colored materials, mullions, or panels; and/or planters; and
 - b) a recognizable top consisting of, but not limited to cornice treatments, other than just colored stripes or bands, with integrally textured materials such as stone or other masonry or differently colored materials; sloping roof with overhangs and brackets; stepped parapets; and/or a cornice capping the top of a building wall.

Innovative planning or design ideas for development in any district where the proposed building types are different than those allowed by the base district requirements may be reviewed as a Conditional-District Zoning.

Required building materials may be substituted with materials that are similar in appearance and durability. Effective December 3, 2007, the requirements of this chapter shall apply to any new zoning permit application unless building elevations were approved as part of a conditional district rezoning.

4.2 DETACHED HOUSE

Description: The detached house is the predominant building type in the City of Belmont. It is flexible in use (where permitted), accommodating single family uses, multi-family uses up to four units, home occupations, professional offices, and limited retail uses. When other building types are integrated with Detached Houses, the scale of the Detached House shall control (exception: Civic Buildings). The use permitted within the building is determined by the District in which it is located.

1. LOT REQUIREMENTS

Type A: Alley Lot The alley lot is a lot where primary vehicular access is provided using a rear lane or alley only. This condition is required for lots less than 55 feet wide and permitted for all others. No curb cuts or driveways are permitted along the frontage except on previously platted lots.

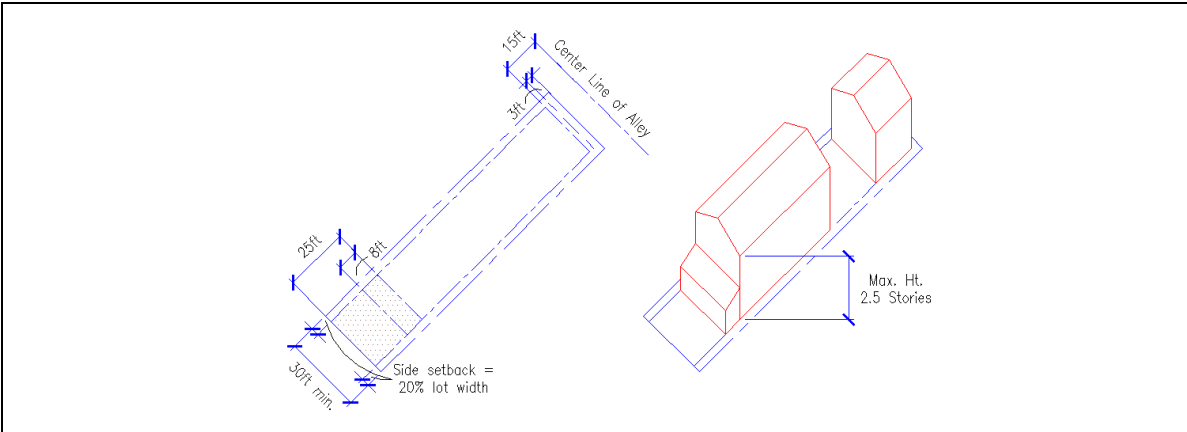

Setbacks: Front yard and side yard setbacks for structures on infill lots shall generally be equal to the average setbacks for all principal structures within 300 ft. or one block length (whichever is greater). Where no frontage condition currently exists, the setbacks shall be as follows:
Front (Maximum): 0-25 ft.
Side: 20% of the lot width or 5 feet on each side whichever is greater. (In new subdivisions, the entire setback may be allocated to one side with a minimum of 10 feet of total building separation)
Rear: Three (3) ft. on lots with an area of less than or equal to 7,000 square feet; otherwise, 15 ft. from centerline of alley or lane
Accessory Structure Setback: See Chapter 3

Minimum Lot Width: 30 Ft
Maximum Height: 2 ½ Stories
Encroachments: Balconies, stoops, stairs, chimneys, open porches, bay windows, and raised doorways are permitted to encroach into the required front or rear setback a maximum of 8 ft.
Lot Coverage (Maximum Impervious): 75%
Vehicular Access to Lot: For lots less than 55 feet wide, alley access is required. For all others the use of an alley is permitted.
 *Excludes Temporary Family Health Care Structures
Performance Standards may vary based on zoning classification. See zoning district classification in Chapter 5.

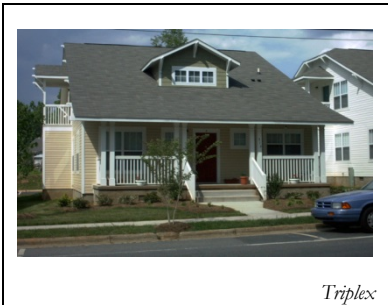

4.2 DETACHED HOUSE

Type B: Street Lot The street lot is a medium or large sized lot (55 feet or greater in width) that provides primary vehicular access from the street.

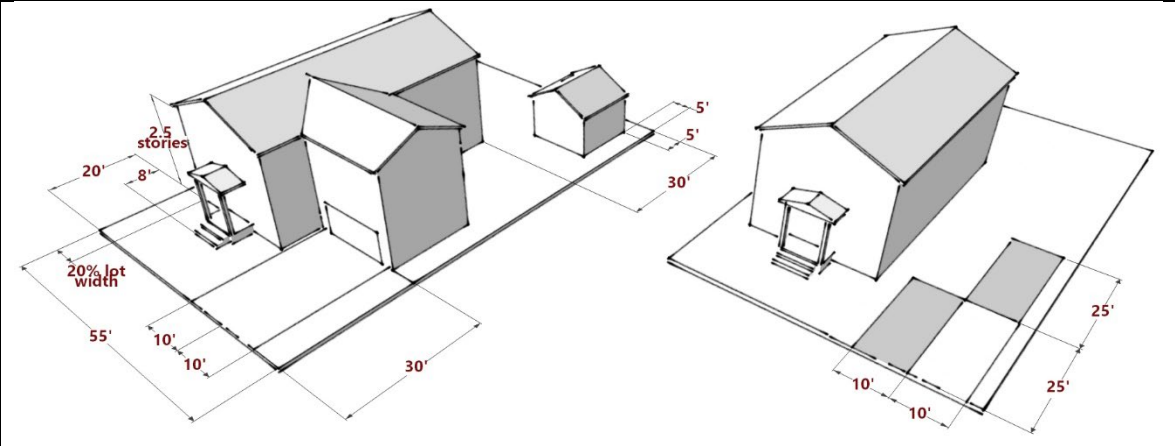

Setbacks: Front yard and side yard setbacks for structures on infill lots shall generally be equal to the average setbacks for all principal structures within 300 ft. or one block length (whichever is less). Where no frontage condition currently exists, the minimum setbacks shall be as follows:

Front: 20 ft. (Exception R-R – 40 ft.)

Sides: 20% of the lot width or 6 feet on each side, whichever is greater. (The entire setback may be allocated to one side with a minimum of 12 feet building separation).

Sides (Infill Lots): Lots $\geq 10,000 \text{ ft}^2 = 12 \text{ ft.}$
 Lots $< 10,000 \text{ ft}^2 = 8 \text{ ft.}$

Rear: 30 ft.

Parking: See section 9.2 (1) for the number of required spaces. Street-facing garages shall include a 30-foot-deep parking pad in front of garage doors. All other homes shall provide a parking pad 25-foot-deep. Parking spaces shall be 10 feet wide (per required space). All required parking pad dimensions are minimum standards and shall be measured from the property line.

Accessory Structure Side/Rear Setback: For lots less than or equal to 7,000 square feet in area there shall be a minimum three (3) ft. setback on side and rear lot lines; otherwise there shall be a minimum side or rear yard setback of five (5) ft. Excludes Temporary Family Health Care Structures. *See Chapter 3 for additional requirements.

Minimum Lot Width: 55 ft.

Maximum Height: 2 1/2 Stories

Encroachments: Balconies, stoops, stairs, chimneys, open porches, bay windows, and raised doorways are permitted to encroach into any required front or rear setback a maximum of 8 ft.

Lot Coverage (Maximum Impervious): 50%

Minimum Lot Size (Duplex Only): 10,000 ft²

Performance Standards may vary based on zoning classification. See zoning district classification in Chapter 5.



4.2 DETACHED HOUSE

2. ARCHITECTURAL REQUIREMENTS

A. General Requirements

- 1. Useable porches and stoops should form a predominate motif of the building design and be located on the front and/or side of the home. Useable front porches are at least 6 feet deep and extend more than 50% of the facade.
- 2. Garages with front loading bays (if permitted) shall be recessed a minimum of one (1) foot from the front facade of the house and visually designed to form a secondary building volume. All garages with more than two bays shall be turned such that the bays are not visible from the street. At no time shall the width of an attached garage door exceed 45% of the total building facade.
- 3. Fences or walls shall be no greater than 8 feet in height behind the front building line. Fences shall be no greater than 4 feet in height and walls no greater than 3 feet in height in the front yard setback.
- 4. Garage doors are not permitted on the front elevation of any detached on a lot less than 55 feet wide.
- 5. Except for Single Family Homes on Type B-Street Lots and Single Family Homes located in neighborhoods developed specifically for seniors, to provide privacy, all front entrances shall be raised from the finished grade (at the frontage line) a minimum of 1½ feet.

B. Materials

- 1. Residential building walls shall be wood clapboard, wood shingle, wood drop siding, primed board, wood board and batten, brick, stone, stucco, approved vinyl, or similar material.

- 2. Garden walls may be of brick, stone or stucco matching the principal building. Front yard fences shall be wood picket, wrought iron or materials similar in appearance and durability. Side and rear yard fences may be chain link, wood, wrought iron, or similar material. All side and rear yard fences over 4 ft. in height shall be wood or similar material.
- 3. Residential roofs shall be clad in wood shingles, standing seam metal, terne, slate, asphalt shingles or similar material.

C. Configurations

- 1. Main roofs on residential buildings shall be symmetrical gables or hips with a pitch between 4:12 and 12:12. Monopitch (shed) roofs are allowed only if they are attached to the wall of the main building. No monopitch roof shall be less than 4:12.
- 2. Two wall materials may be combined on one façade with the material that is more substantial in appearance (e.g., brick, stone or faux stone are deemed more substantial in appearance than materials such as vinyl, stucco or cementitious fiber siding) being below.
- 3. The undercroft of buildings shall be enclosed.

D. Techniques

- 1. Overhanging eaves may expose rafters.
- 2. Flush eaves shall be finished by profiled molding or gutters.



4.3 TOWNHOUSE

Description: The townhouse is a building with two or more residential units that are located side-by-side. When an entrance is provided at-grade, the townhouse may be used as a live-work unit. The use permitted within the building is determined by the District in which it is located.

1. LOT REQUIREMENTS

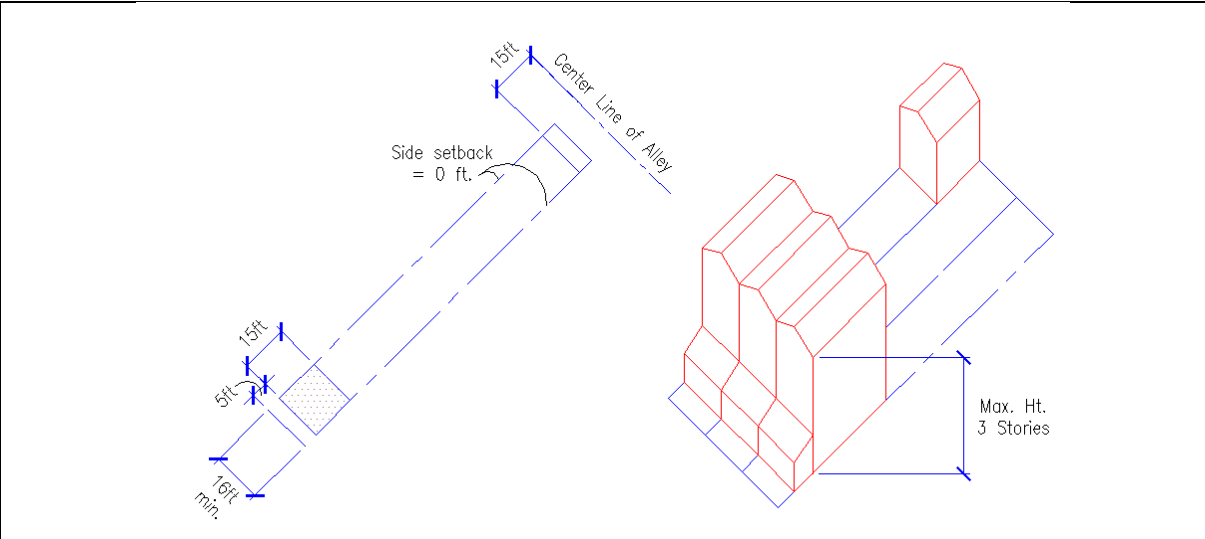

Setbacks:
Front (Maximum): 0-25 ft.
Sides: 0 ft. (Corner-6 ft.)
Rear: 15 ft. from centerline of alley or lane

Parking and Vehicular Access: Primary vehicular access is provided using a rear lane or alley only. Off-street parking shall be located in the rear yard only. No curb cuts or driveways are permitted along the frontage.

Performance Standards may vary based on zoning classification. See zoning district classification in Chapter 5.

Minimum Lot Width: 16 Ft
Maximum Height: 3 Stories

Encroachments: Balconies, stoops, stairs, chimneys, open porches, bay windows, and raised doorways are permitted to encroach within the front yard. Upper story balconies may encroach into the right-of-way up to 5 feet with permission from the City.

Accessory Structures:
Side/Rear Setback: 0 ft.
Maximum Footprint: 650 sq. ft.
Maximum Number of Structures: 1



4.3 TOWNHOUSE

2. ARCHITECTURAL REQUIREMENTS

A. General Requirements

1. Useable porches and stoops should form a predominate motif of the building design and be located on the front and/or side of the building. Useable front porches are at least 6 feet deep and extend more than 50% of the facade.
2. Garage doors are not permitted on the front elevation of any townhouse building.
3. Fences or walls shall be no greater than 8 feet in height behind the front building line. Fences shall be no greater than 4 feet in height and walls no greater than 3 feet in height in the front yard setback.
4. All building elevations visible from the street shall provide doors, porches, balconies, and/or windows. A minimum of 60% of front elevations, and a minimum of 30% of side and rear building elevations, as applicable, shall meet this standard. "Percent of elevation" is measured as the horizontal plane (lineal feet) containing doors, porches, balconies, terraces and/or windows. This standard applies to each full and partial building story.
5. To provide privacy, all front entrances shall be raised from the finished grade (at the building line) a minimum of 1½ feet.
6. All multi-family and infill buildings shall provide detailed design along all elevations. Detailed design shall be provided by using at least three (3) of the following architectural features on all elevations as appropriate for the proposed building type and style (may vary features on rear/side/front elevations):
 - a. Dormers
 - b. Gables
 - c. Recessed entries
 - d. Covered porch entries
 - e. Cupolas or towers
 - f. Pillars or posts
 - g. Eaves (minimum 6 inch projection)
 - h. Off-sets in building face or roof (minimum 16 inches) Window trim (minimum 4 inches wide)
 - i. Bay windows
 - j. Balconies
 - k. Decorative patterns on exterior finish (e.g. scales/shingles, wainscoting, ornamentation, and similar features)
 - l. Decorative cornices and roof lines (for flat roofs)

B. Materials

1. Residential building walls shall be wood clapboard, wood shingle, wood drop siding, primed board, wood board and batten, brick, stone, stucco, approved vinyl, or similar material.
2. Garden walls may be of brick, stone or stucco matching the principal building. Front yard fences shall be wood picket, wrought iron or materials similar in appearance and durability. Side and rear yard fences may be chain link, wood, wrought iron, or similar material. All side and rear yard fences over 4 ft. in height shall be wood or similar material.
3. Residential roofs shall be clad in wood shingles, standing seam metal, terne, slate, asphalt shingles or similar material.

C. Configurations

1. Main roofs on residential buildings shall be symmetrical gables or hips with a pitch between 4:12 and 12:12. Monopitch (shed) roofs are allowed only if they are attached to the wall of the main building. No monopitch roof shall be less than 4:12.
2. Two wall materials may be combined horizontally on one facade. The heavier material should be below.
3. The undercroft of buildings shall be enclosed.

D. Techniques

1. All buildings should be designed to adhere to the existing architectural pattern of the surrounding neighborhood.
2. Overhanging eaves may expose rafters.
3. Flush eaves shall be finished by profiled molding or gutters.
4. All rooftop equipment shall be screened from view.

4.4 APARTMENT BUILDING

Description: A multiple-unit building with apartments vertically arranged and with parking located below or behind the building. Units may be for rental or for sale in condominium ownership or may be designed as continuing care facilities. The ground floor may be available for commercial uses. The use permitted within the building is determined by the District in which it is located.

1. LOT REQUIREMENTS

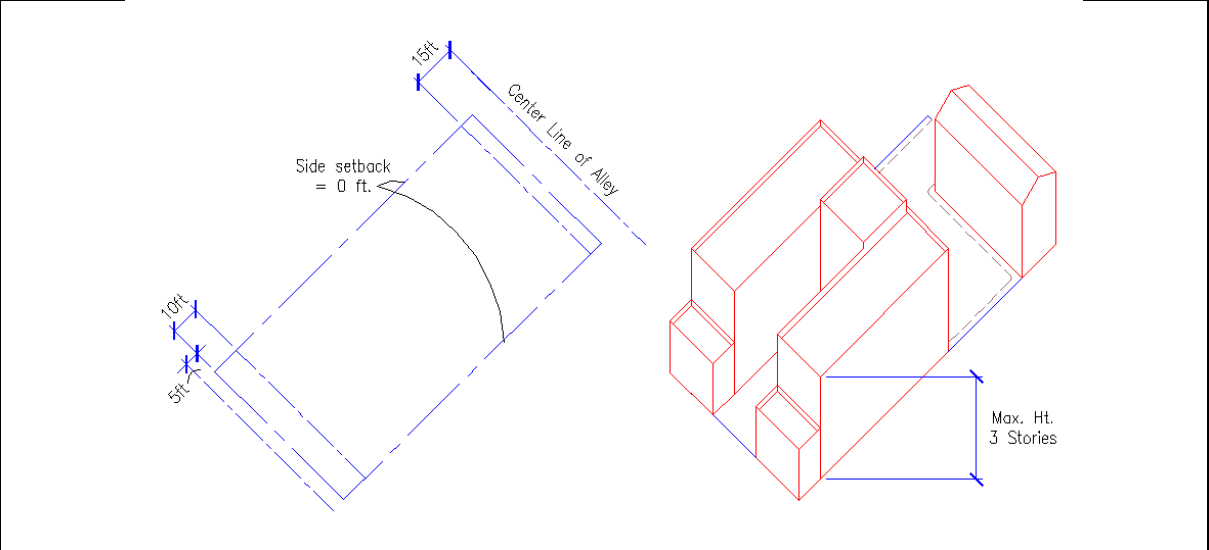

Setbacks:
Front (Maximum): 0-25 ft.
Sides: 0 ft. (Corner-4 ft.)
Rear: 15 ft. from centerline of alley or lane

Parking and Vehicular Access: Primary vehicular access is provided using a rear lane or alley only. Off-street parking shall be located in the rear yard only; except on corner lots where parking areas and structures may be allowed in the side yard subject to the issuance of a special use permit or Conditional District Zoning. No curb cuts or driveways are permitted along the frontage except for vehicular access to rear parking.

Performance Standards may vary based on zoning classification. See zoning district classification in Chapter 5.

Maximum Height: 3 Stories

Accessory Structures:
Side/Rear Setback: 0 ft.
Maximum Footprint: 1,300 sq. ft.

Accessory structures over 1,300 sq. ft. are subject to the issuance of a special use permit or Conditional District Zoning.

Encroachments: Balconies, stoops, stairs, chimneys, open porches, bay windows, and raised doorways are permitted to encroach into the front setback. Upper story balconies may encroach into the right-of-way up to 5 feet with permission from the City.



4.4 APARTMENT BUILDING

2. ARCHITECTURAL REQUIREMENTS

A. General Requirements

1. Useable porches and stoops should form a predominate motif of the building design and be located on the front and/or side of the building. Useable front porches are at least 6 feet deep and extend more than 50% of the facade.
2. Garage doors are not permitted on the front elevation of any apartment building.
3. Fences or walls shall be no greater than 8 feet in height behind the front building line. Fences shall be no greater than 4 feet in height and walls no greater than 3 feet in height in the front yard setback.
4. All building elevations visible from the street shall provide doors, porches, balconies, and/or windows. A minimum of 60% of front elevations, and a minimum of 30% of side and rear building elevations, as applicable, shall meet this standard. "Percent of elevation" is measured as the horizontal plane (lineal feet) containing doors, porches, balconies, terraces and/or windows. This standard applies to each full and partial building story.
5. To provide privacy, all front entrances shall be raised from the finished grade (at the building line) a minimum of 1½ feet.
6. All multi-family and infill buildings shall provide detailed design along all elevations. Detailed design shall be provided by using at least three (3) of the following architectural features on all elevations as appropriate for the proposed building type and style (may vary features on rear/side/front elevations):
 - a. Dormers
 - b. Gables
 - c. Recessed entries
 - d. Covered porch entries
 - e. Cupolas or towers
 - f. Pillars or posts
 - g. Eaves (minimum 6 inch projection)
 - h. Off-sets in building face or roof (minimum 16 inches) Window trim (minimum 4 inches wide)
 - i. Bay windows
 - j. Balconies
 - k. Decorative patterns on exterior finish (e.g. scales/shingles, wainscoting, ornamentation, and similar features)
 - l. Decorative cornices and roof lines (for flat roofs)

B. Materials

1. Residential building walls shall be wood clapboard, wood shingle, wood drop siding, primed board, wood board and batten, brick, stone, stucco, approved vinyl, or similar material.
2. Garden walls may be of brick, stone or stucco matching the principal building. Front yard fences shall be wood picket, wrought iron or materials similar in appearance and durability. Side and rear yard fences may be chain link, wood, wrought iron, or similar material. All side and rear yard fences over 4 ft. in height shall be wood or similar material.
3. Residential roofs shall be clad in wood shingles, standing seam metal, terne, slate, asphalt shingles or similar material.

C. Configurations

1. Main roofs on residential buildings shall be symmetrical gables or hips with a pitch between 4:12 and 12:12. Monopitch (shed) roofs are allowed only if they are attached to the wall of the main building. No monopitch roof shall be less than 4:12.
2. Two wall materials may be combined horizontally on one facade. The heavier material should be below.
3. Exterior chimneys shall be finished in brick, siding, or other similar material.
4. The undercroft of buildings shall be enclosed.

D. Techniques

1. All buildings should be designed to adhere to the existing architectural pattern of the surrounding neighborhood.
2. Overhanging eaves may expose rafters.
3. Flush eaves shall be finished by profiled molding or gutters.
4. All rooftop equipment shall be screened from view.

4.5 SHOPFRONT BUILDING

Description : A small scale structure which can accommodate a variety of uses. A group of shopfront buildings can be combined to form a mixed-use neighborhood center. Individual shopfront buildings can be used to provide some commercial service, such a neighborhood store, in close proximity to homes. Office buildings, hotels and inns can be placed in shopfront buildings. The use permitted within the building is determined by the District in which it is located.

1. LOT REQUIREMENTS

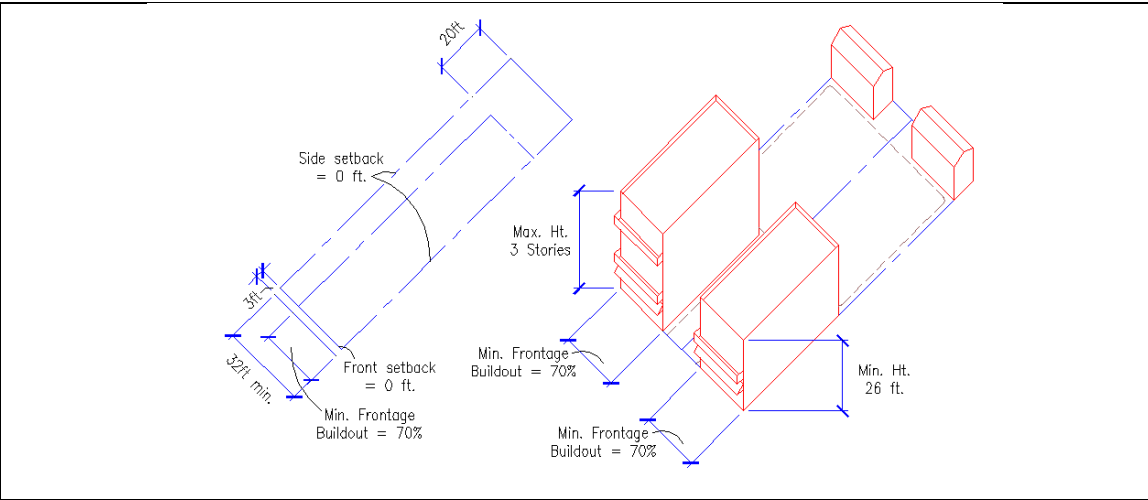

Minimum Height: 26 ft.
Maximum Height: 3 Stories (42 feet)

Setbacks:
Front (Maximum): 0 ft.
Sides: 0 ft.
Rear: 20 ft.

Frontage Buildout (Min.): 70%

Parking and Vehicular Access: Primary vehicular access is provided using a rear lane or alley only. Off-street parking shall be located in the rear yard only. No curb cuts or driveways are permitted along the frontage.

Minimum Lot Width: 32 ft. (Lots platted prior to 1995 – 16 ft.)

Encroachments: Upper story balconies may encroach into the right-of-way up to 3 feet with permission from the City.

Accessory Structures:
Side/Rear Setback: 0 ft.

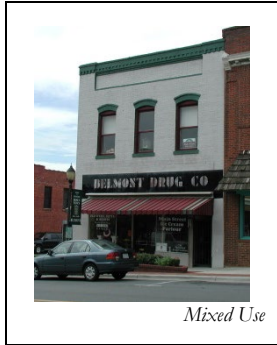

4.5 SHOPFRONT BUILDING

2. ARCHITECTURAL REQUIREMENTS

A. General Requirements

1. At least 70% of the width of street level frontages shall be in windows or doorways. Street level windows shall be visually permeable. Mirrorized glass is not permitted in any location. Faux or display casements are not permitted in lieu of exterior window treatments for the frontage elevation.
2. No frontage wall shall remain unpierced by a window or functional general access doorway for more than 16 feet.
3. The principal, functional doorway for public or direct-entry access into a building shall be from the fronting street. Corner entrances may be provided on corner lot buildings.
4. Decorative cornices shall be provided for buildings with a flat roof. Alternatively, eaves shall be provided with a pitched roof.
5. A building canopy, awning, or similar weather protection may be provided and should project 3-5 feet from the façade.

B. Materials

1. Commercial building walls shall be brick, cast concrete, stone, marble, or other materials similar in appearance and durability. Regular or decorative concrete block and EIFS-type stucco may be used on building walls not visible from a public street or as an accent material only. All accessory buildings shall be clad in materials similar in appearance to the principal structure.
2. Pitched roofs shall be clad in wood shingles, standing seam metal, corrugated metal, slate, asphalt shingles or similar material.
3. Signs on the inside of glazed openings may be neon.

4. Rear and side yard fences and walls shall be brick, stucco, wrought iron, stone, or materials similar in appearance and durability. Maximum fence and wall height shall be 8 feet.

C. Configurations

1. All visibly exposed facades shall have a recognizable base course, which shall align with the sill level of the first story consisting of, but not limited to: thicker walls, ledges or sills; integrally textured materials such as stone or other masonry; integrally colored and patterned materials such as smooth finished stone or tile; lighter or darker colored materials, mullions, or panels; and/or planters.
2. All visibly exposed facades shall have a recognizable top consisting of, but not limited to: cornice treatments, other than just colored stripes or bands, with integrally textured materials such as stone or other masonry or differently colored materials; sloping roof with overhangs and brackets; stepped parapets; and/or a cornice which shall terminate or cap the top of a building wall.
3. Two wall materials may be combined horizontally on one facade. The heavier material should be below.
4. Sky-lights shall be flat (non-bubble).

D. Techniques

1. Stucco shall be float finish.
2. Windows shall be set to the inside of the building face wall.
3. All rooftop equipment shall be screened from view.



4.6 WORKPLACE BUILDING

Description: A building available for manufacturing and its related functions. Offices within the building should front the street. Loading is accommodated to the rear. Existing industrial buildings may be converted to loft buildings which are defined as multiple-unit buildings with units available for either residential or commercial use. The ceilings must be high to permit a greater distance from windows required in commercial units. Units may be for rental or for sale in condominium ownership. The use permitted within the building is determined by the District in which it is located.

1. LOT REQUIREMENTS

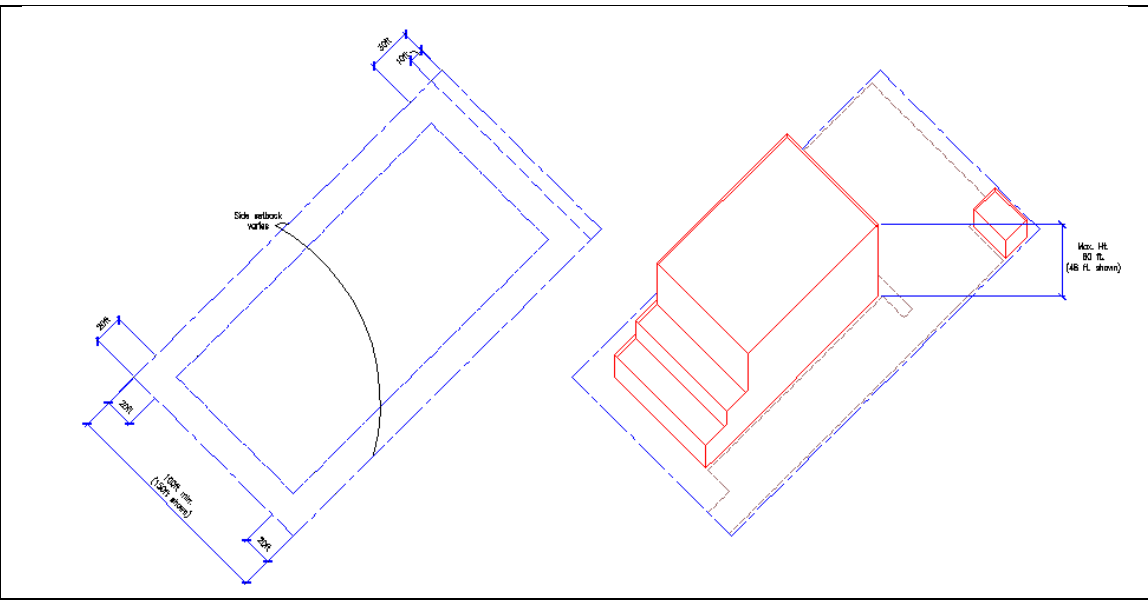

Setbacks: Front yard and side yard setbacks for structures on infill lots shall generally be equal to the average setbacks for all principal structures within 300 ft. or one block length (whichever is greater). Where no frontage condition currently exists, the minimum setbacks shall be as follows:

Front: 10 - 20 ft.
Side: varies
Rear: 30
Accessory Structure Setback: 10 ft.
Rear/Side Parking Setback: 10 ft.

Minimum Lot Width: 100 Ft
Minimum Lot Size: 1 acre

Maximum Height: 60 ft. in BC-D/IC-D otherwise three stories

Parking and Vehicular Access: Off-street parking shall be located in the side or rear yard only except as permitted in the underlying district. A circulation driveway is permitted in the front yard.



4.6 WORKPLACE BUILDING

2. ARCHITECTURAL REQUIREMENTS

A. Materials

1. All building walls visible from a public street shall be brick, cast concrete, stucco, stone, marble, decorative concrete masonry unit or other materials similar in appearance and durability.
2. Pitched roofs shall be clad in wood shingles, standing seam metal, corrugated metal, slate, diamond tab asphalt shingles or similar material.
3. Front and side yard fences and walls shall be brick, stucco, wrought iron, stone, or materials similar in appearance and durability. Maximum fence height shall be 5 feet. Rear yard fences and walls shall be made of brick, stucco, wrought iron, stone, wood, chain linked, or similar material. (barbed wire fences are only permitted in rear yards not visible from a street). Maximum fence height shall be 8 feet.

B. Configurations

1. Two wall materials may be combined horizontally on one facade. The heavier material should be below.
2. Skylights shall be flat (non-bubble).

C. Techniques

1. Stucco shall be float finish.
2. Windows shall be set to the inside of the building face wall.
3. All rooftop equipment shall be screened from view.

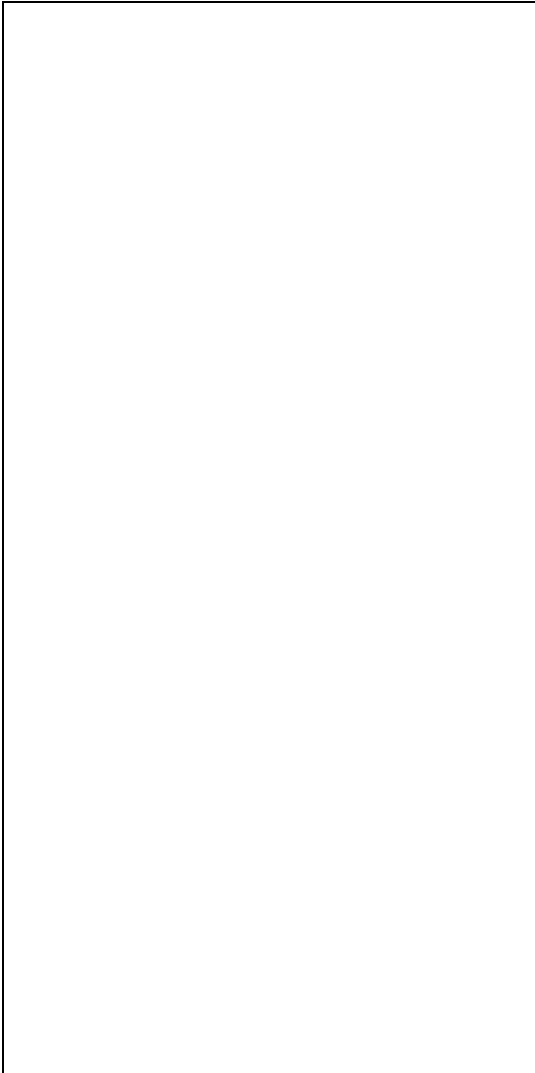

4.7 FLEX COMMERCIAL BUILDING

Description: Similar to a shopfront in use, the highway commercial building is specifically coded for automobile-oriented uses that are found along Wilkinson Boulevard and in circumstances allowed under the NC-C zoning district provisions found in chapter 5.6. This building type provides convenient automobile access from the fronting thoroughfare, while minimizing the negative impacts of parking lots on an active pedestrian realm. The use permitted within the building is determined by the District in which it is located.

1. LOT REQUIREMENTS

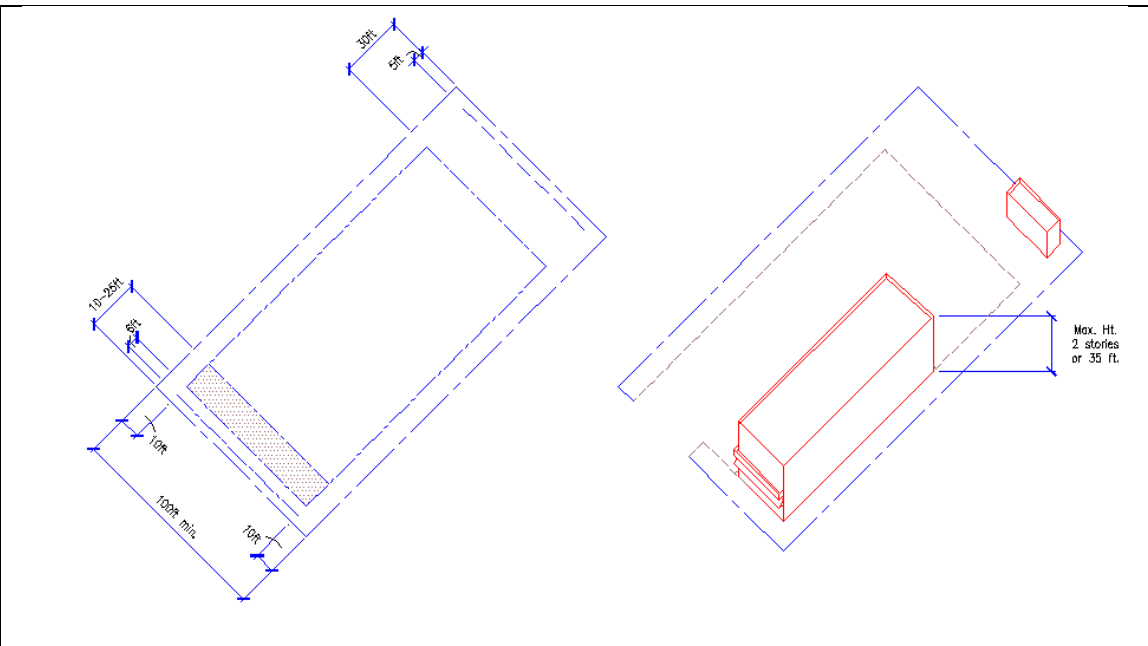

Setbacks: Front yard and side yard setbacks for structures on infill lots should generally be equal to the average setbacks for all principal structures within 300 ft. or one block length (whichever is greater). Where no frontage condition currently exists, the minimum setbacks shall be as follows:

- Front:** 10ft
- Side:** 4 (8 ft. for corner lot)
- Rear:** 30 ft.
- Accessory Structure Setback:** 5 ft.

Minimum Lot Width: 100 Ft
Maximum Height: 2 stories or 35 feet, whichever is less

Encroachments: Balconies, stoops, stairs, open porches, and raised doorways are permitted to encroach into the front setback a maximum of 6 ft.

Parking and Vehicular Access: Off-street parking shall be located in the side or rear yard only except as permitted in the underlying district. A circulation driveway is permitted in the front yard.



4.7 FLEX COMMERCIAL BUILDING

2. ARCHITECTURAL REQUIREMENTS

A. General Requirements

1. Street level windows shall be visually permeable. Mirrorized glass is not permitted in any location. Faux or display casements are not permitted in lieu of exterior window treatments for the frontage elevation.
2. No frontage wall shall remain unpierced by a window or functional general access doorway for more than 32 feet.
3. The principal, functional doorway for public or direct-entry access into a building shall be from the fronting street and located in the front half of the building (side entries permitted). Corner entrances shall be provided on corner lot buildings.
4. Decorative cornices shall be provided for buildings with a flat roof. Alternatively, eaves shall be provided with a pitched roof.
5. A building canopy, awning, or similar weather protection may be provided and should project 3-5 feet from the façade.

B. Materials

1. Commercial building walls shall be brick, cast concrete, stone, marble, or other materials similar in appearance and durability. Regular or decorative concrete block and EIFS-type stucco may be used on building walls not visible from a public street or as an accent material only.

Existing flex-commercial structures with non-conforming building wall materials may upgrade to EIFS-type stucco, Dryvit®, or an architectural panel resembling these materials. If an architectural panel is proposed, planning department staff shall have final approval of the material, on a case-by-case basis, after a physical sample has been submitted.

2. Pitched roofs shall be clad in wood shingles, standing seam metal, corrugated metal, slate, asphalt shingles or similar material.
3. Signs on the inside of glazed openings may be neon.

4. Front and side yard fences and walls shall be brick, stucco, wrought iron, stone, or materials similar in appearance and durability. Maximum fence height shall be 5 feet. Rear yard fences and walls shall be made of brick, stucco, wrought iron, stone, wood, chain linked, or similar material. (barbed wire fences are only permitted in rear yards not visible from a street). Maximum fence height shall be 8 feet.

C. Configurations

1. All visibly exposed facades shall have a recognizable base course, which shall align with the sill level of the first story consisting of, but not limited to: thicker walls, ledges or sills; integrally textured materials such as stone or other masonry; integrally colored and patterned materials such as smooth finished stone or tile; lighter or darker colored materials, mullions, or panels; and/or planters.
2. All visibly exposed facades shall have a recognizable top consisting of, but not limited to: cornice treatments, other than just colored stripes or bands, with integrally textured materials such as stone or other masonry or differently colored materials; sloping roof with overhangs and brackets; stepped parapets; and/or a cornice which shall terminate or cap the top of a building wall.
3. Two wall materials may be combined horizontally on one facade. The heavier material should be below.
4. Sky-lights shall be flat (non-bubble).

D. Techniques

1. Stucco shall be float finish.
2. Windows shall be set to the inside of the building face wall.
3. All rooftop equipment shall be screened from view.



Gas Station



Pharmacy with Drive Thru

4.8 CIVIC/INSTITUTIONAL BUILDING

Description: Specialized buildings intended to serve as public gathering places. Such uses include governmental offices, churches or other places of worship, schools, hospitals, post offices, and non-profit or charitable clubs and organizations.

1. LOT REQUIREMENTS

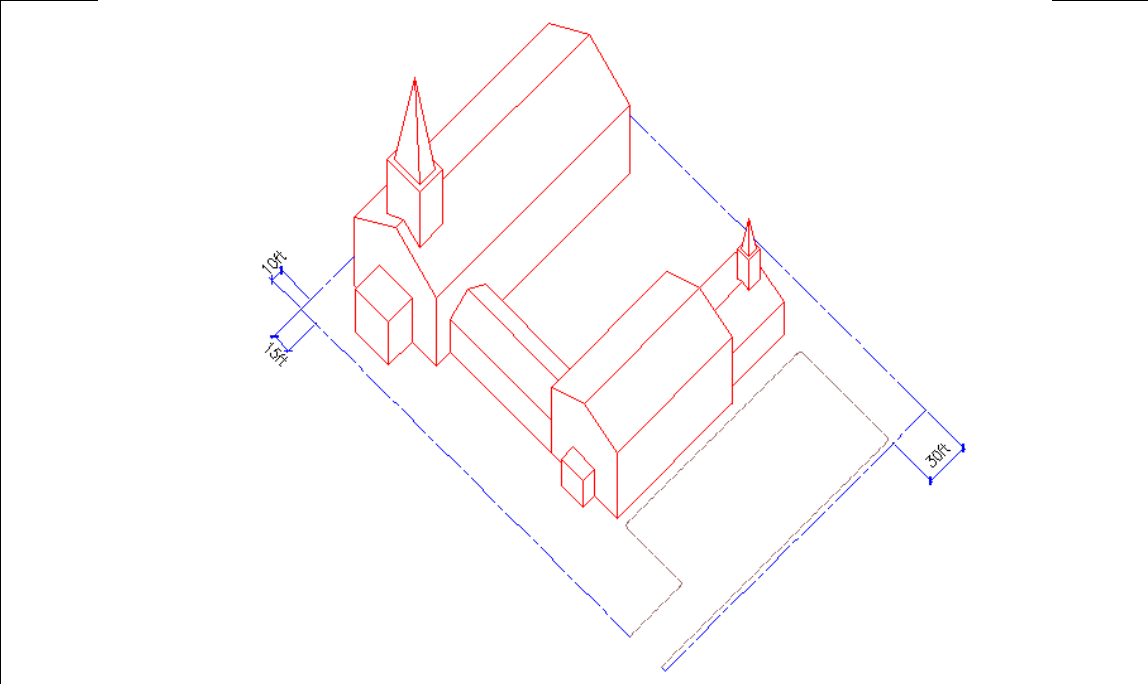

Setbacks (Minimum):
Front: 0 ft.
Sides: 15
Rear: 30 ft.

Accessory Structures less than 500 ft²:
 (Used Primarily for Storage, max 2 Permitted)
 Side and Rear Setback: 5ft.
 Maximum Height: 15 ft.

Accessory Structures greater than 500 ft²:
 Side and Rear Setback: 20 ft.
 Maximum Height: 26 ft.

Minimum Lot Width: 70 Ft
Minimum Lot Size: none

Maximum Height: 3 Stories (Exception R-R, G-R – 2 Stories)

Encroachments: Balconies, stoops, stairs, open porches, bay windows, and raised doorways are permitted to encroach into the front setback a maximum of 10 ft.

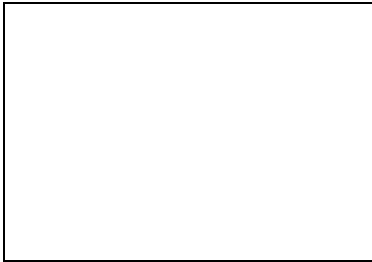
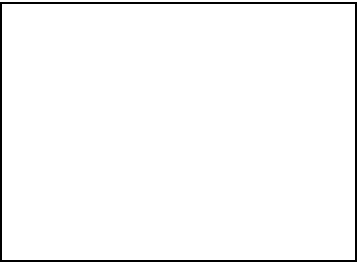

4.8 CIVIC/INSTITUTIONAL BUILDING

B. ARCHITECTURAL REQUIREMENTS

A. General Requirements

1. Schools, churches, and government buildings should be built so that they terminate a street vista whenever possible, and shall be of sufficient design to create visual anchors for the community.
2. Off-street parking shall be provided in the side or rear yards only.
3. Building(s) incidental to the principal structure shall be behind a line a minimum of 20 ft. from the front facade of the structure, and if more than one, shall be arranged to create secondary gathering spaces within the lot.
4. Parking shall be located towards the interior of the lot. On-street parking may be used to fulfill parking requirements. Parking may not occur within a front setback or corner side setback.
5. Front setbacks may be altered to preserve views or significant trees.

B. Materials

1. Civic building walls shall be clad in clapboard, stone, stucco, brick, or marble. Decorative cast concrete and wood or vinyl siding may be used as a secondary element on facades facing public streets.
2. Civic roofs shall be clad in slate, sheet metal, corrugated metal, or asphalt shingles, or other material similar in appearance and durability.
3. Gutters and down spouts shall be made of copper or galvanized painted metal, or other material similar in appearance and durability.
4. The orders, if provided, shall be made of wood or cast concrete.
5. Stained glass or other decorative window treatments are encouraged.
6. Front and side yard fences and walls shall be brick, stucco, wrought iron, stone, or materials similar in appearance and durability. Maximum fence height shall be 6 feet. Rear yard fences and walls shall be brick, stucco, wrought iron, stone, wood, chain linked, or similar material. Maximum fence height shall be 8 feet. For security and safety reasons, public safety station (police/fire departments, etc.) fences shall be exempt from the above requirements but shall be subject to review by the Planning Department in accordance with the spirit and intent of this ordinance.

C. Configurations

1. Two wall materials may be combined horizontally on one facade. The heavier material should be below.
2. Flat roofs are allowed, but principal civic buildings adjacent to residential structures are encouraged to have pitched roofs or similar architectural features to ensure compatibility.

D. Techniques

1. Windows shall be set to the inside of the building face wall.
2. All rooftop equipment shall be screened from view.