

U:\2019 Projects\HN28 - South Fork Site (Public)\X0005\sheet\HN28-INDEX.dwg, Layout, eaidson

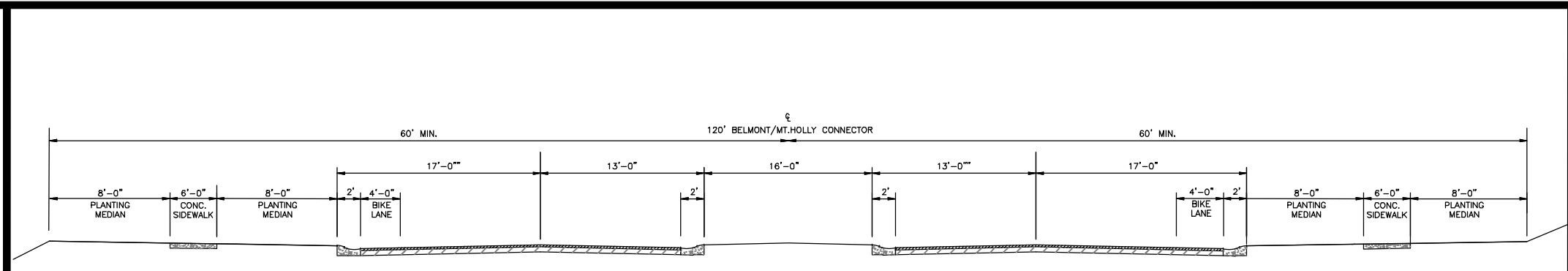

120' Belmont/Mt.Holly Connector ROW

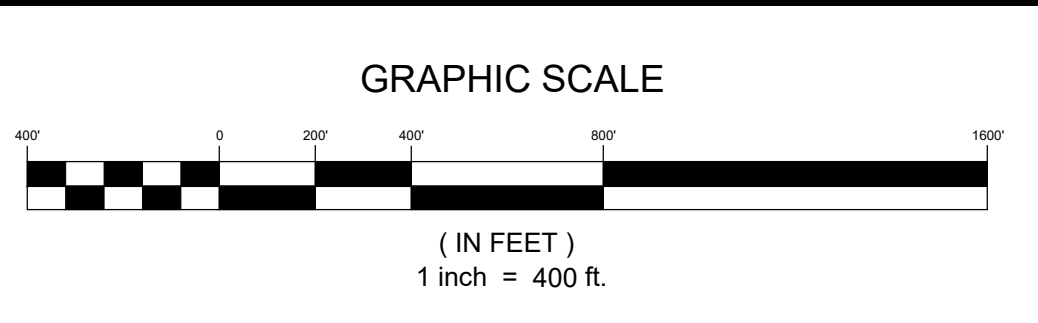
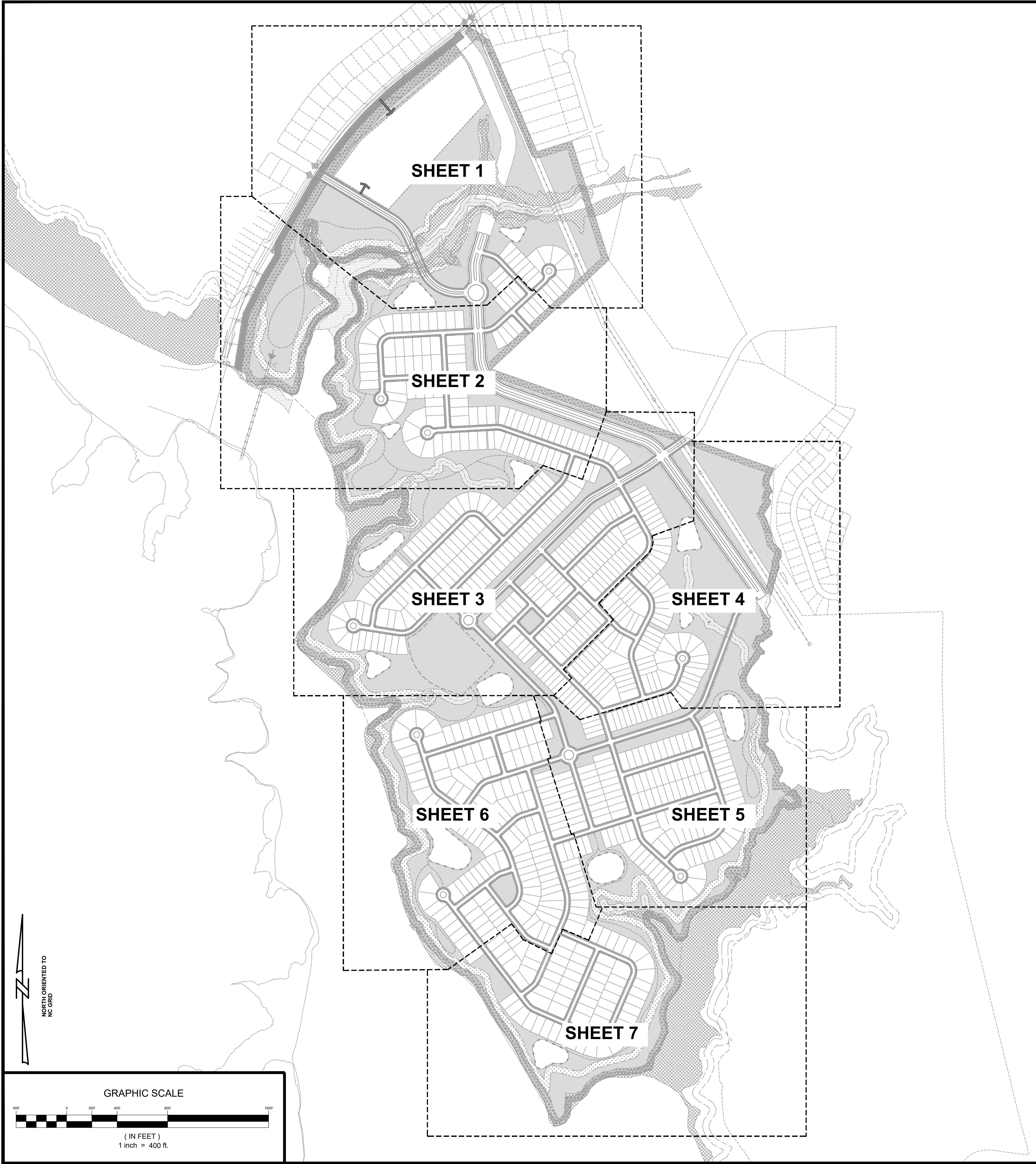
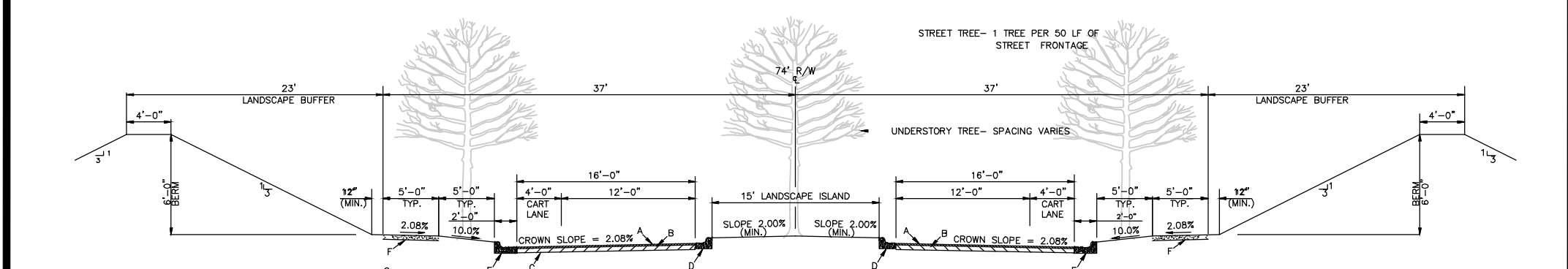

74' Internal Boulevard ROW

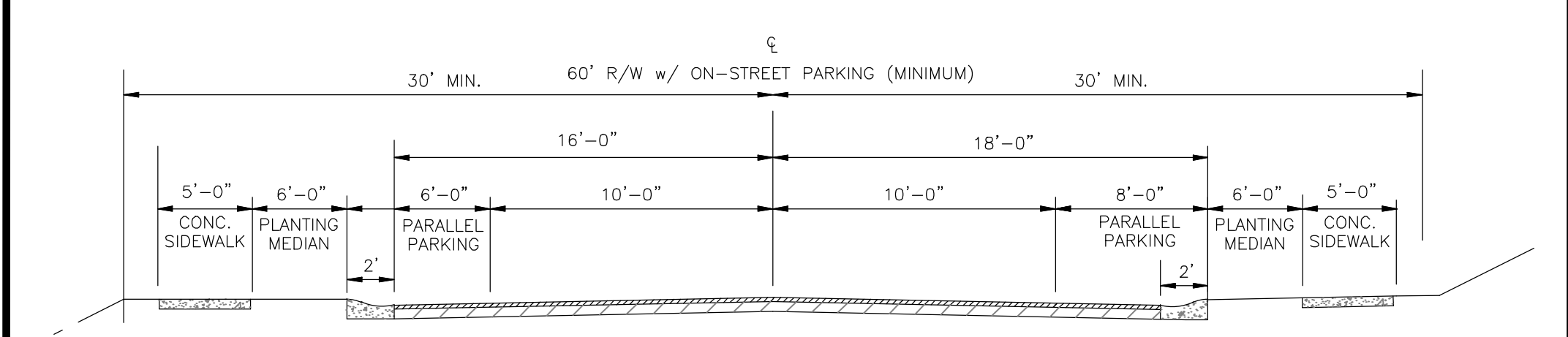

60' Public ROW (with On-Street Parking)

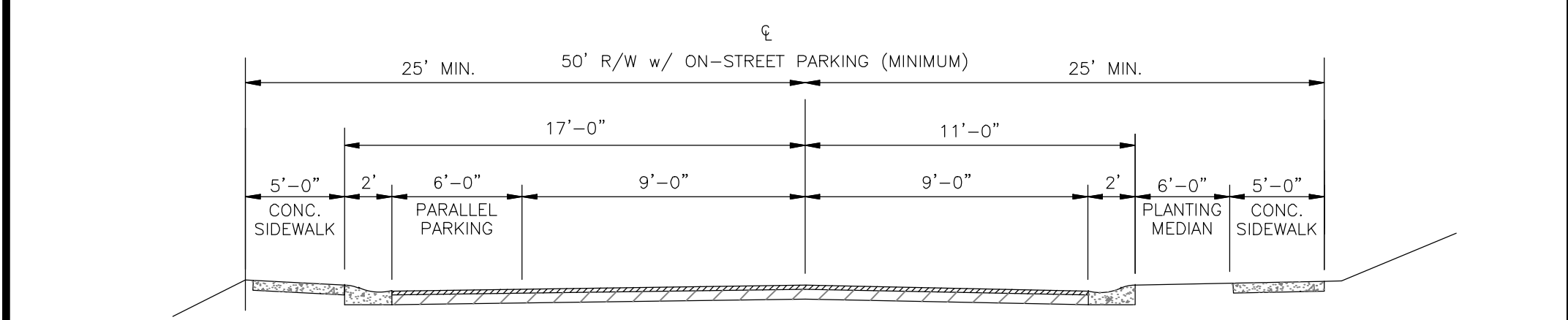

50' Public ROW (with On-Street Parking)

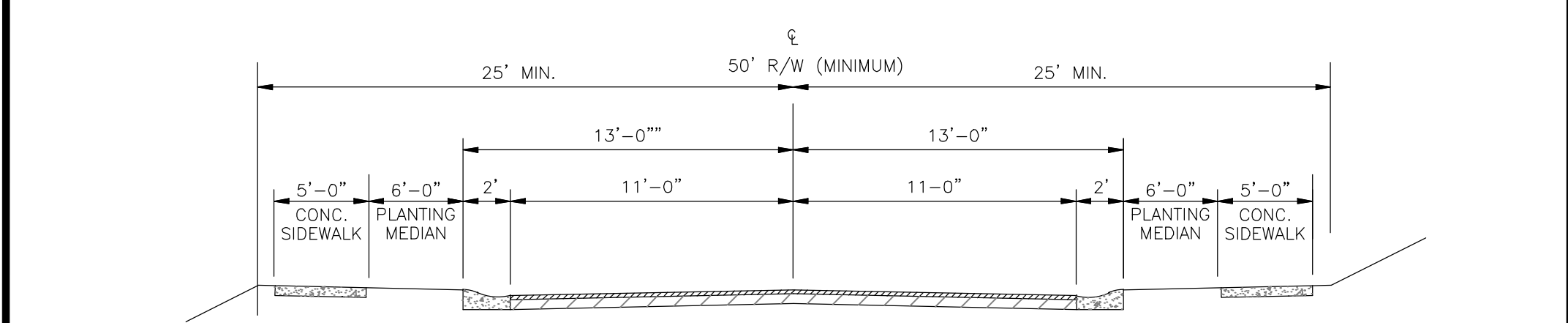

50' Public ROW

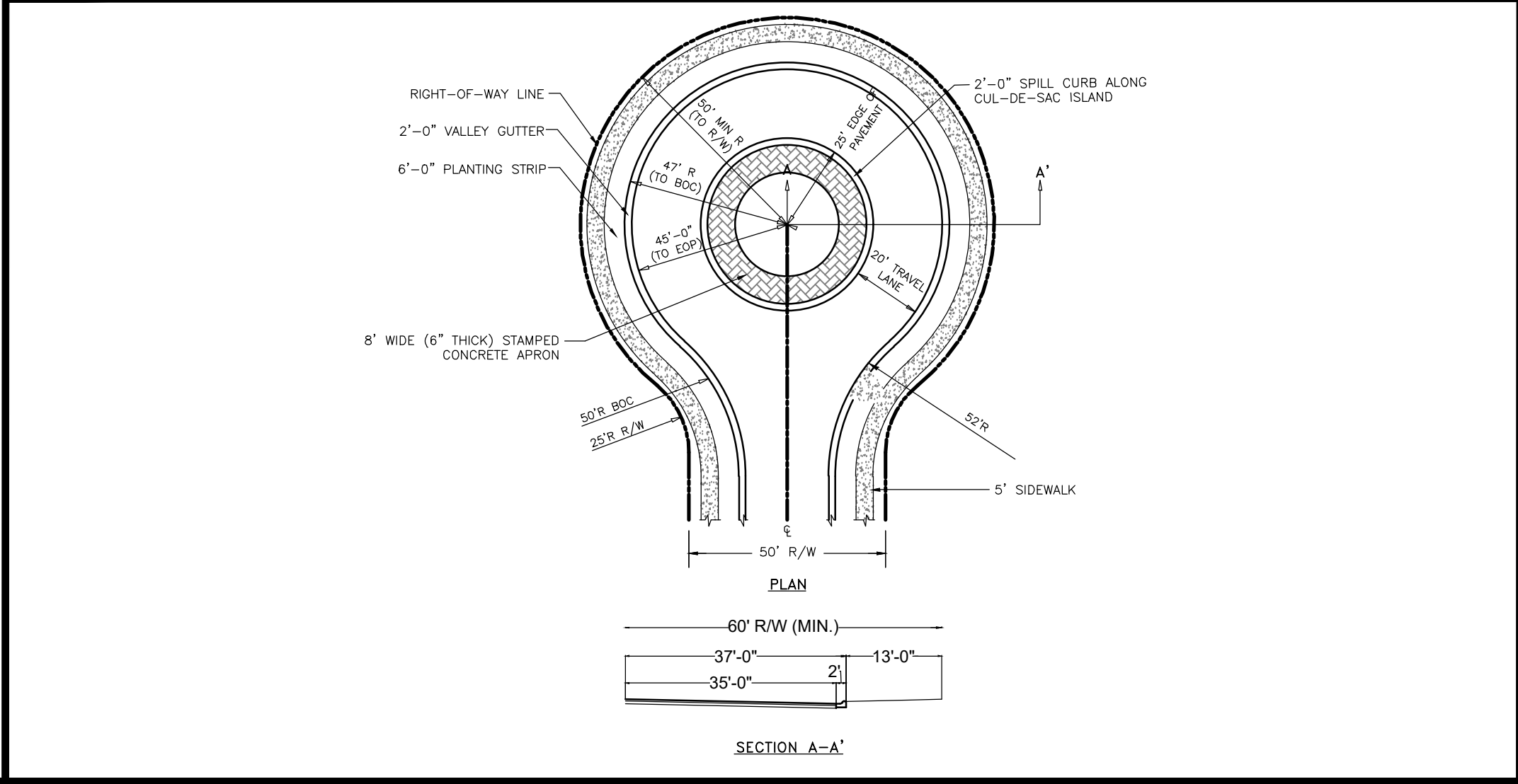

SECTION A-A'

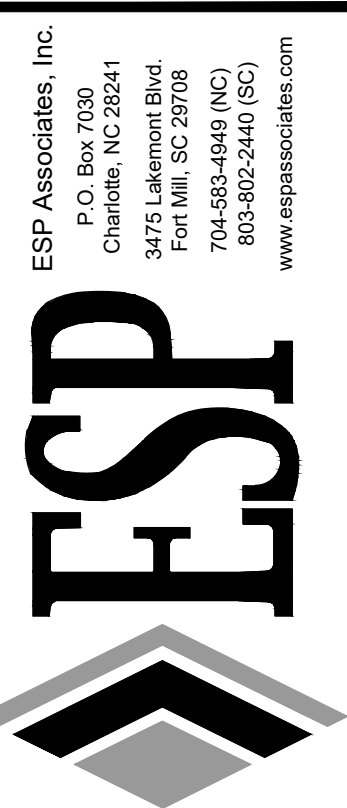

NO.	DATE	REVISION	BY

SCHEMATIC PLAN - INDEX

SOUTH FORK SITE

CITY OF BELMONT, NORTH CAROLINA

PULTE GROUP, INC.

PROJECT INFORMATION	
PROJECT MANAGER:	MM
DESIGNED BY:	AB
DRAWN BY:	SW
PROJECT NUMBER:	HN28.100
ORIGINAL DATE:	06/05/2020
SHEET:	INDEX

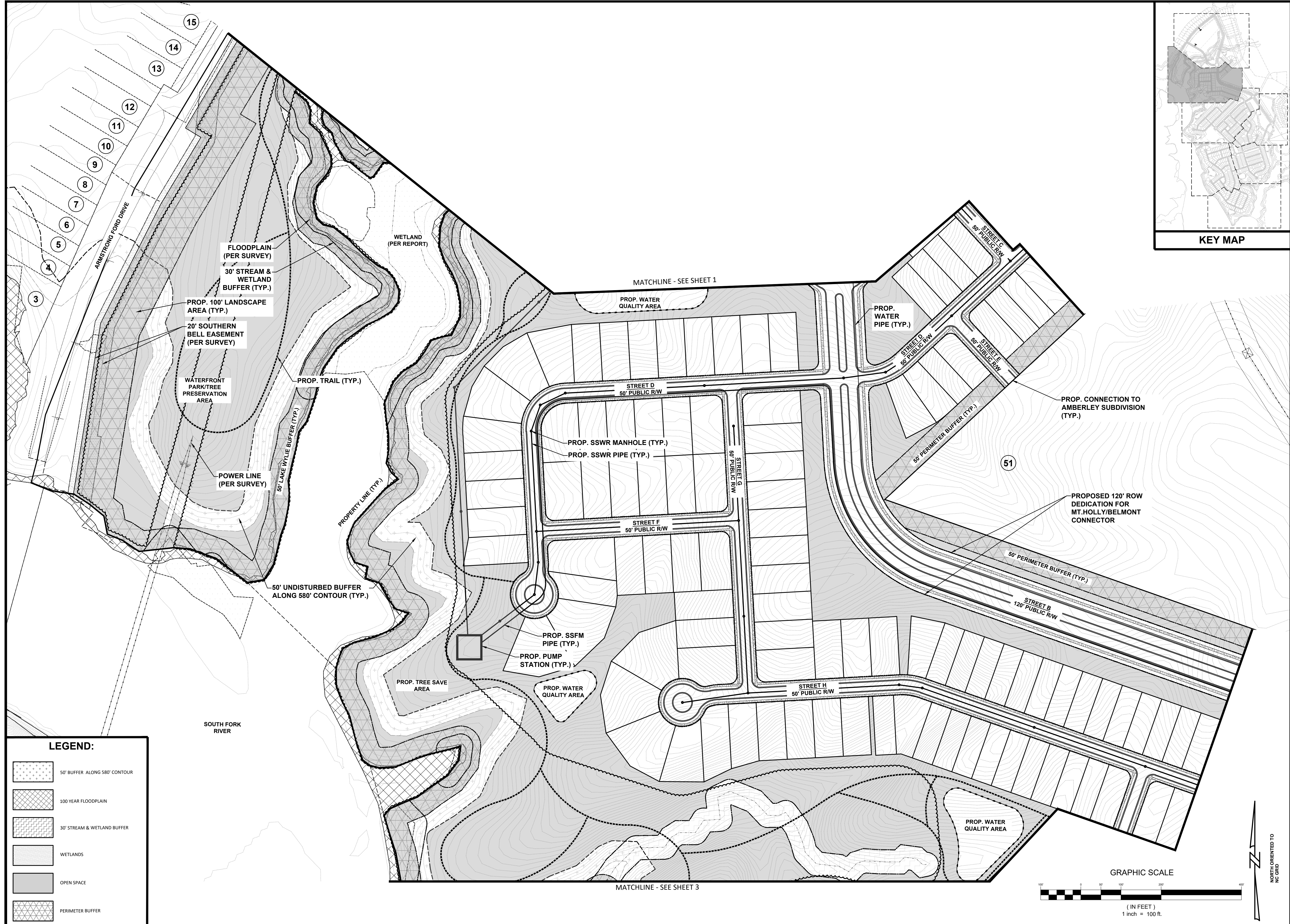

LEGEND:

	50' BUFFER ALONG 580' CONTOUR
	100 YEAR FLOODPLAIN
	30' STREAM & WETLAND BUFFER
	WETLANDS
	OPEN SPACE
	PERIMETER BUFFER

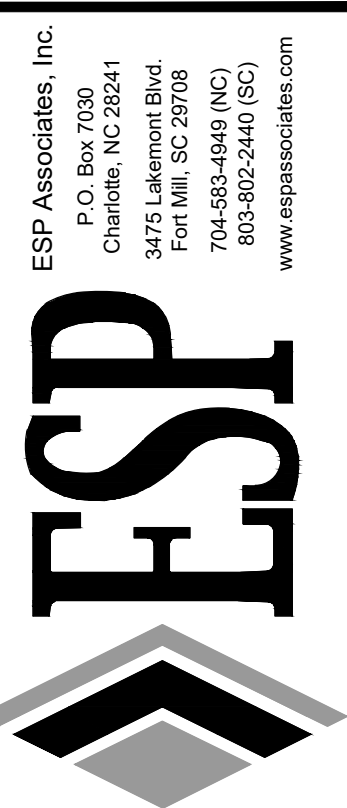
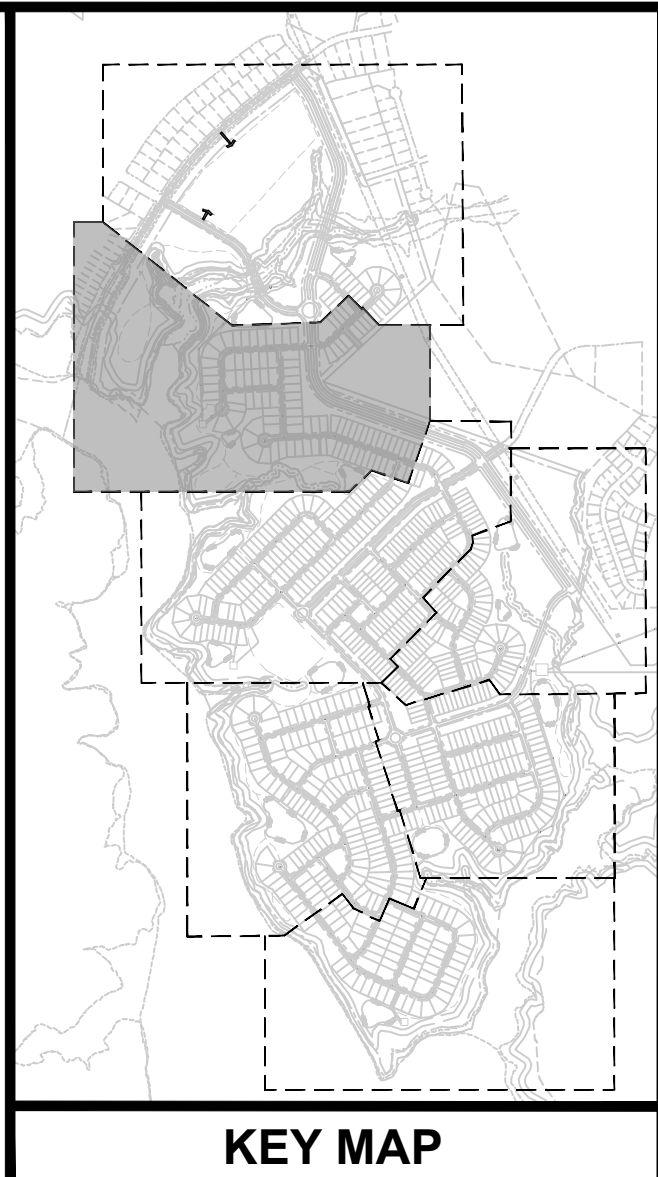

NO.	DATE	REVISION	BY

PROJECT INFORMATION

PROJECT MANAGER:	MM
DESIGNED BY:	AB
DRAWN BY:	SW
PROJECT NUMBER:	HN28.100
ORIGINAL DATE:	06/05/2020
SHEET:	2 OF 8

SOUTH FORK SITE
 CITY OF BELMONT, NORTH CAROLINA
 PULTE GROUP, INC.

U:\2019 Projects\HN28_South Fork_Site (Pulte)_X0005888\HN28-SHEETS.dwg, SHEET 2, revision

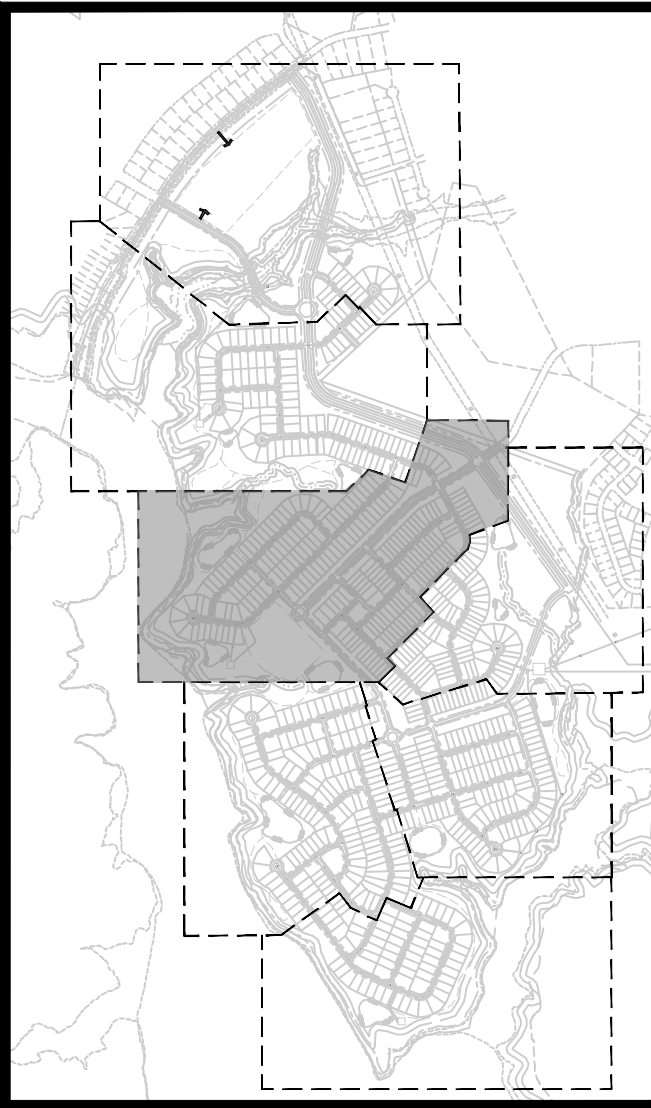

LEGEND:

- 50' BUFFER ALONG 580' CONTOUR
- 100 YEAR FLOODPLAIN
- 30' STREAM & WETLAND BUFFER
- WETLANDS
- OPEN SPACE
- PERIMETER BUFFER

KEY MAP

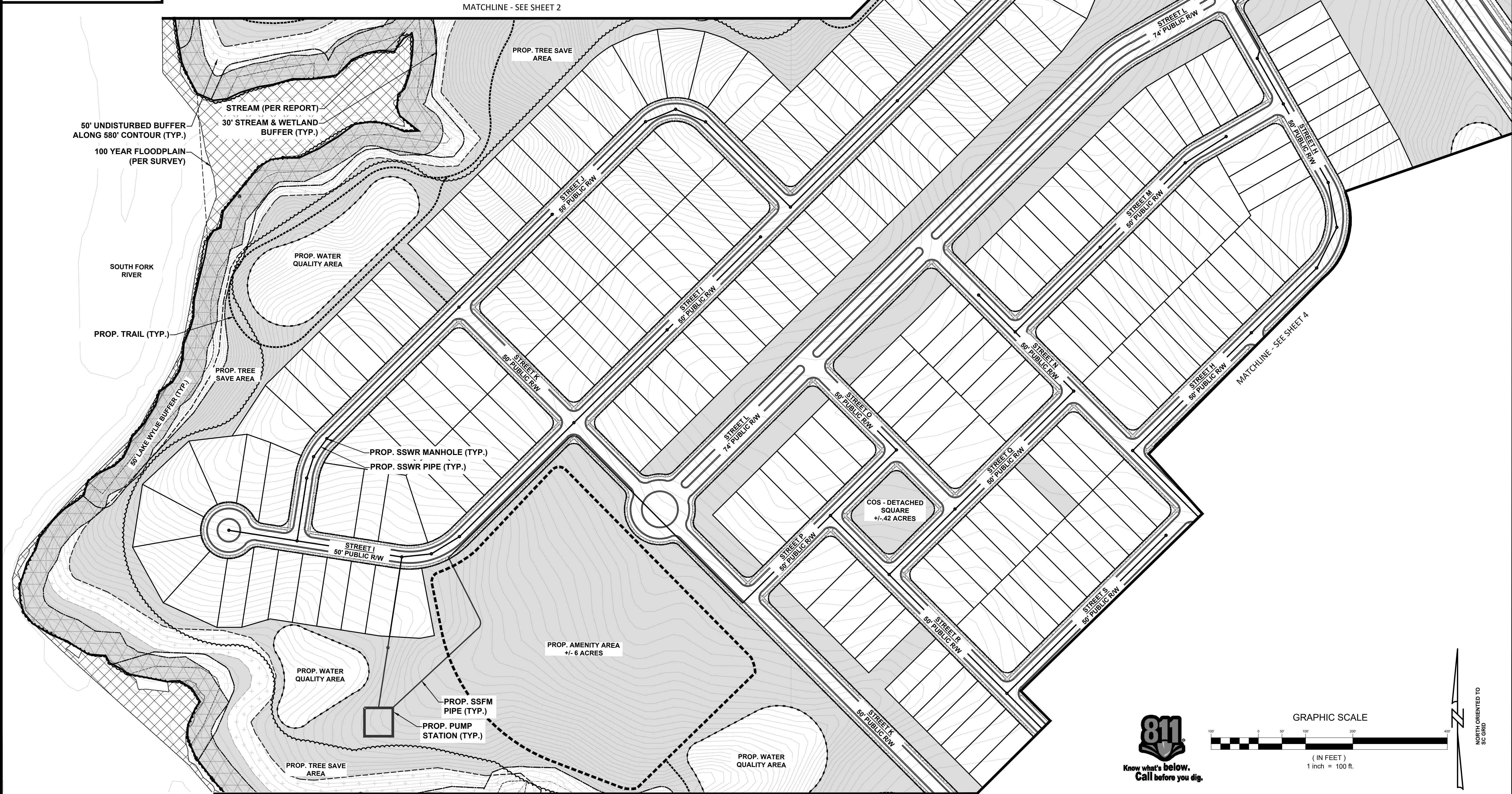

ESP Associates, Inc.
 P.O. Box 7030
 Charlotte, NC 28241
 3475 Lakemont Blvd.
 Fort Mill, SC 29708
 704-583-0440 (NC)
 803-802-2440 (SC)
 www.espasociates.com

NO.	DATE	REVISION

PROJECT INFORMATION

PROJECT MANAGER:	MM
DESIGNED BY:	AB
DRAWN BY:	SW
PROJECT NUMBER:	HN28.100
ORIGINAL DATE:	06/05/2020
SHEET:	3 OF 8

SOUTH FORK SITE
 CITY OF BELMONT, NORTH CAROLINA
 PULTE GROUP, INC.

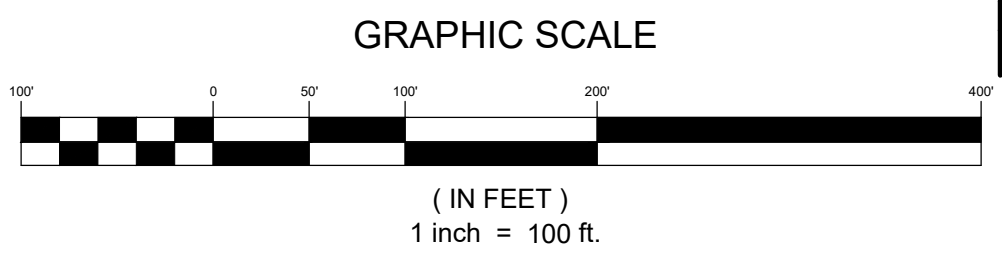







U:\2019 Projects\HN28 - South Fork Site (Pulte)\X0005866\HN28-SHEETS.dwg, SHEET 3, revision

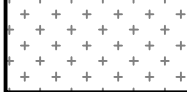

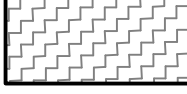
KEY MAP

LEGEND:

-  50' BUFFER ALONG 580' CONTOUR
-  100 YEAR FLOODPLAIN
-  30' STREAM & WETLAND BUFFER
-  WETLANDS
-  OPEN SPACE
-  PERIMETER BUFFER

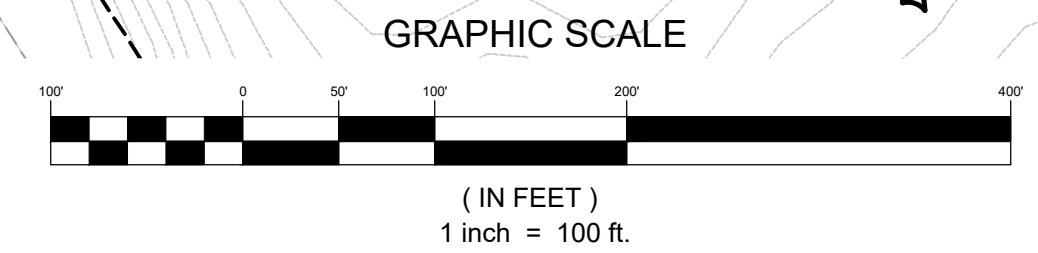
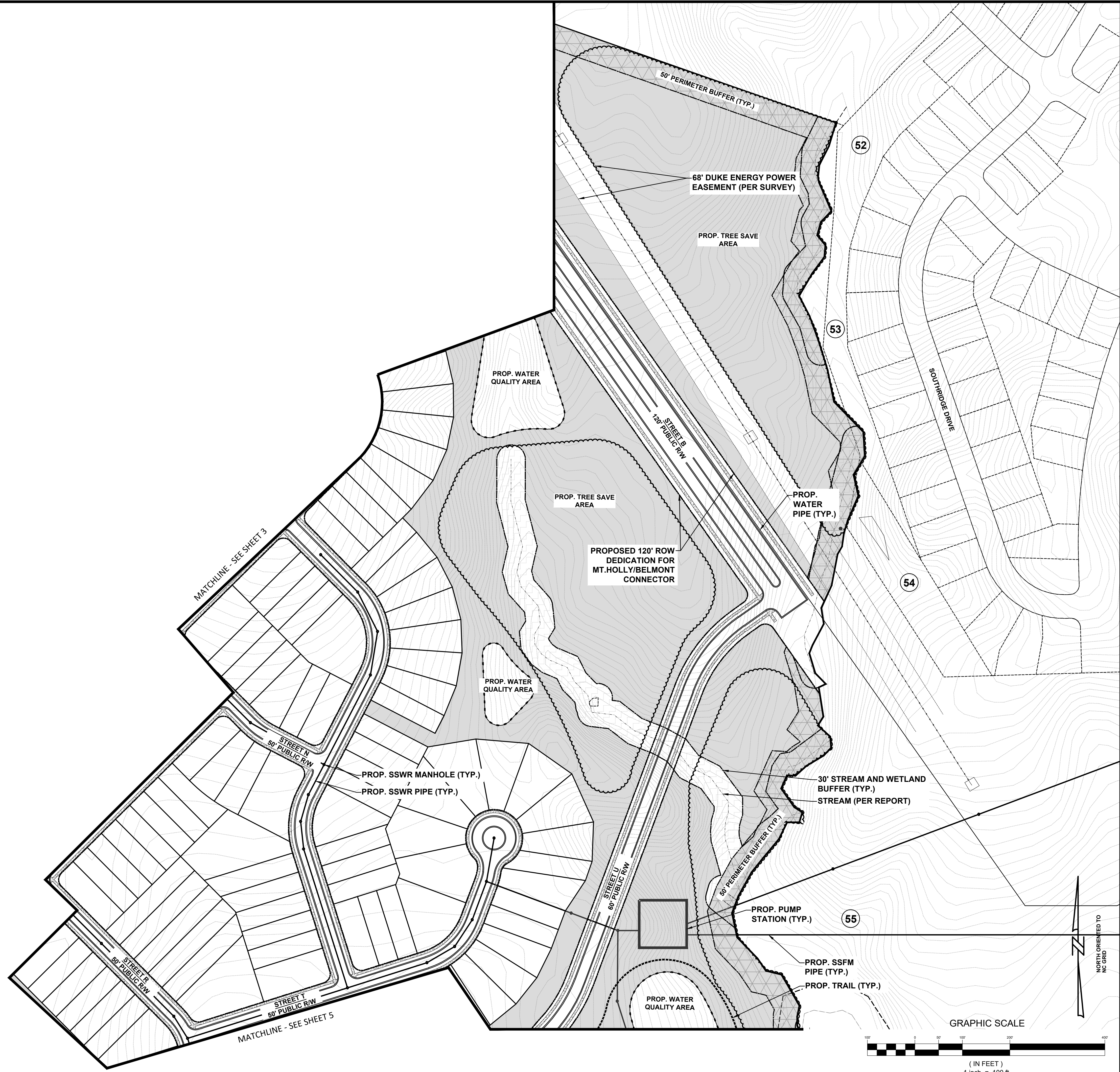

ESP Associates, Inc.
P.O. Box 7003
Charlotte, NC 28241
3475 Lakemont Blvd.
Fort Mill, SC 29708
704-583-9449 (NC)
803-802-2440 (SC)
www.espassociates.com

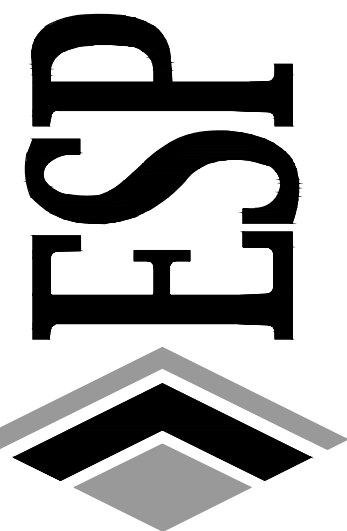

NO.	DATE	REVISION

SCHEMATIC PLAN
(SHEET 4 OF 8)

SOUTH FORK SITE
CITY OF BELMONT, NORTH CAROLINA

PULTE GROUP, INC.

PROJECT INFORMATION	
PROJECT MANAGER:	MM
DESIGNED BY:	AB
DRAWN BY:	SW
PROJECT NUMBER:	HN28.100
ORIGINAL DATE:	06/05/2020
SHEET:	4 OF 8

U:\2019 Projects\HN28 - South Fork Site (Pulte)\X0005888\HN28-SHEETS.dwg, SHEET 4, redson

MATCHLINE - SEE SHEET 3

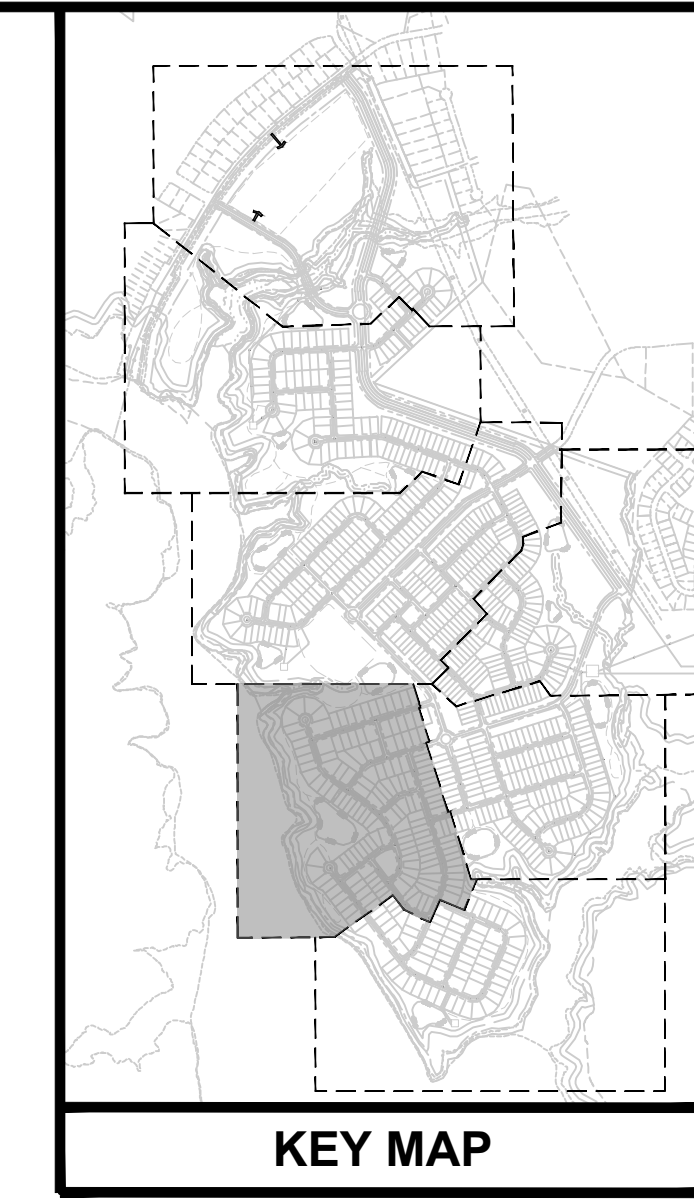

LEGEND:

- 50' BUFFER ALONG 580' CONTOUR
- 100 YEAR FLOODPLAIN
- 30' STREAM & WETLAND BUFFER
- WETLANDS
- OPEN SPACE
- PERIMETER BUFFER

ESP Associates, Inc.
 P.O. Box 7003
 Charlotte, NC 28241
 3475 Lakemont Blvd.
 Fort Mill, SC 29708
 704-583-0440 (NC)
 803-502-2440 (SC)
 www.espasociates.com



NO.	DATE	REVISION	BY

SCHEMATIC PLAN
 (SHEET 5 OF 8)

SOUTH FORK SITE
 CITY OF BELMONT, NORTH CAROLINA
 PULTE GROUP, INC.

PROJECT INFORMATION

PROJECT MANAGER:	MM
DESIGNED BY:	AB
DRAWN BY:	SW
PROJECT NUMBER:	HN28.100
ORIGINAL DATE:	06/05/2020
SHEET:	5 OF 8

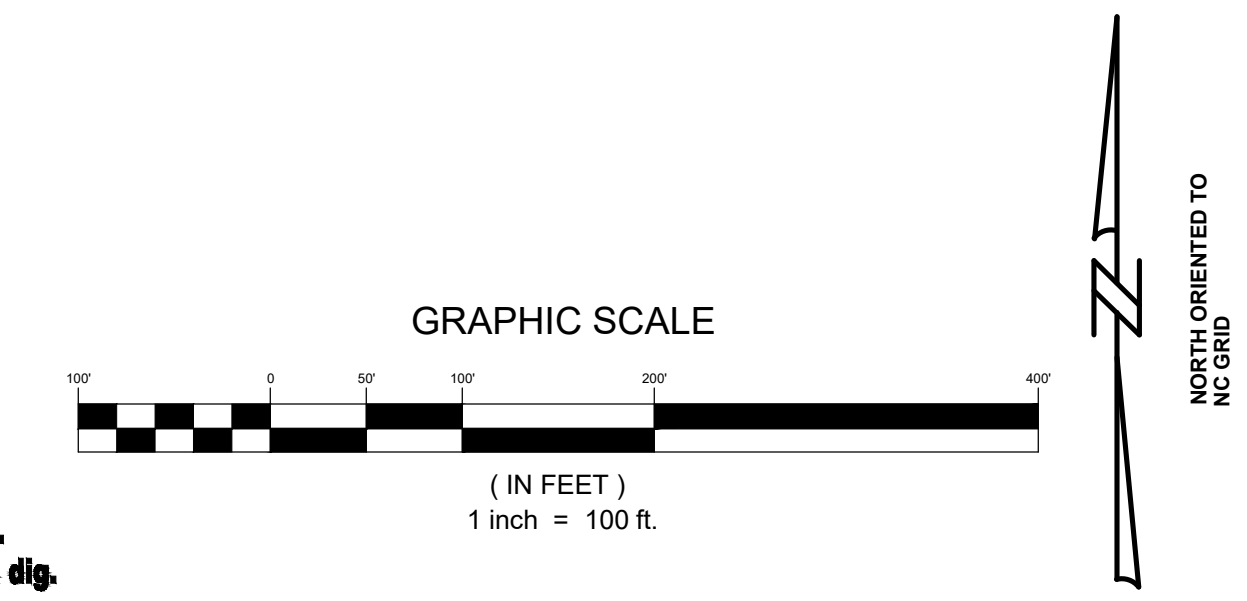

U:\2019 Projects\HN28 - South Fork Site (Pulte)\X000\Sheet\HN28-SHEETS.dwg, SHEET 5, redson

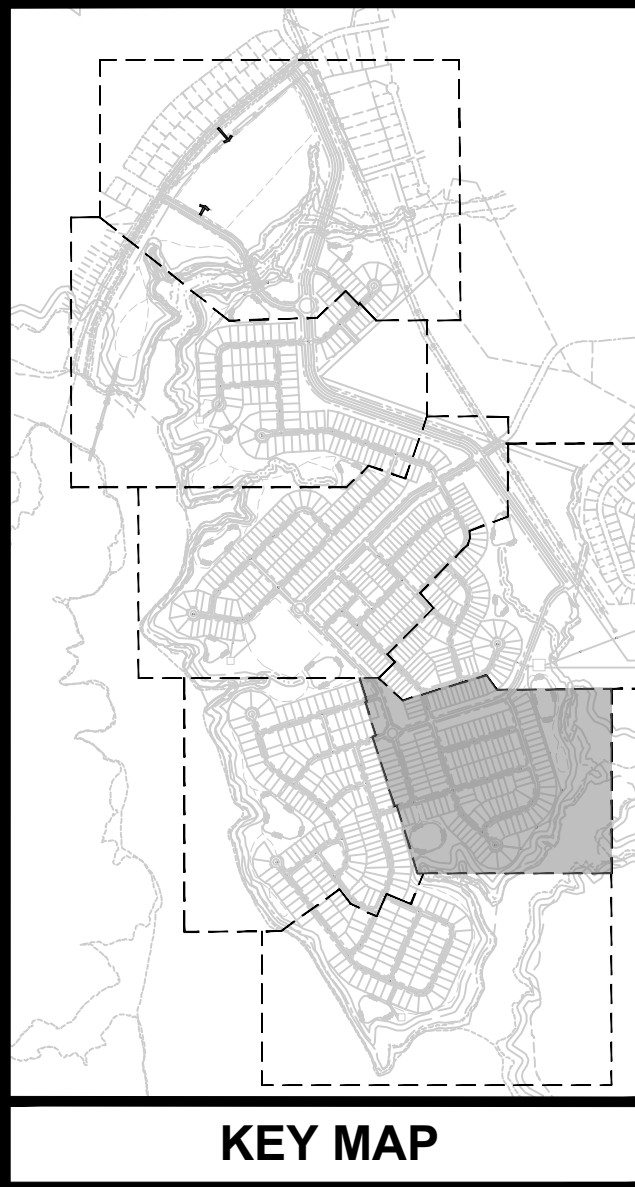

LEGEND:

- 50' BUFFER ALONG 580' CONTOUR
- 100 YEAR FLOODPLAIN
- 30' STREAM & WETLAND BUFFER
- WETLANDS
- OPEN SPACE
- PERIMETER BUFFER



NORTH ORIENTED TO
N.C. GRID

GRAPHIC SCALE
(IN FEET)
1 inch = 100 ft.

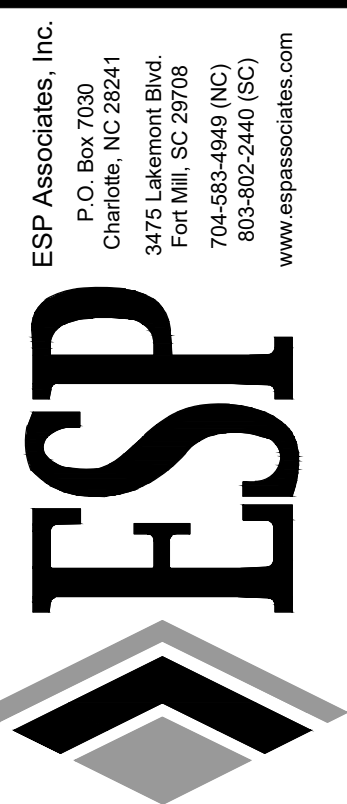

NO.	DATE	REVISION	BY

PROJECT INFORMATION

PROJECT MANAGER: MM
 DESIGNED BY: AB
 DRAWN BY: SW
 PROJECT NUMBER: HN28.100
 ORIGINAL DATE: 06/05/2020
 SHEET:

6 OF 8

SOUTH FORK SITE
 CITY OF BELMONT, NORTH CAROLINA
 PULTE GROUP, INC.

U:\2019 Projects\HN28 - South Fork Site (Pulte)\X000\Sheet\HN28-SHEETS.dwg, SHEET 6, redson

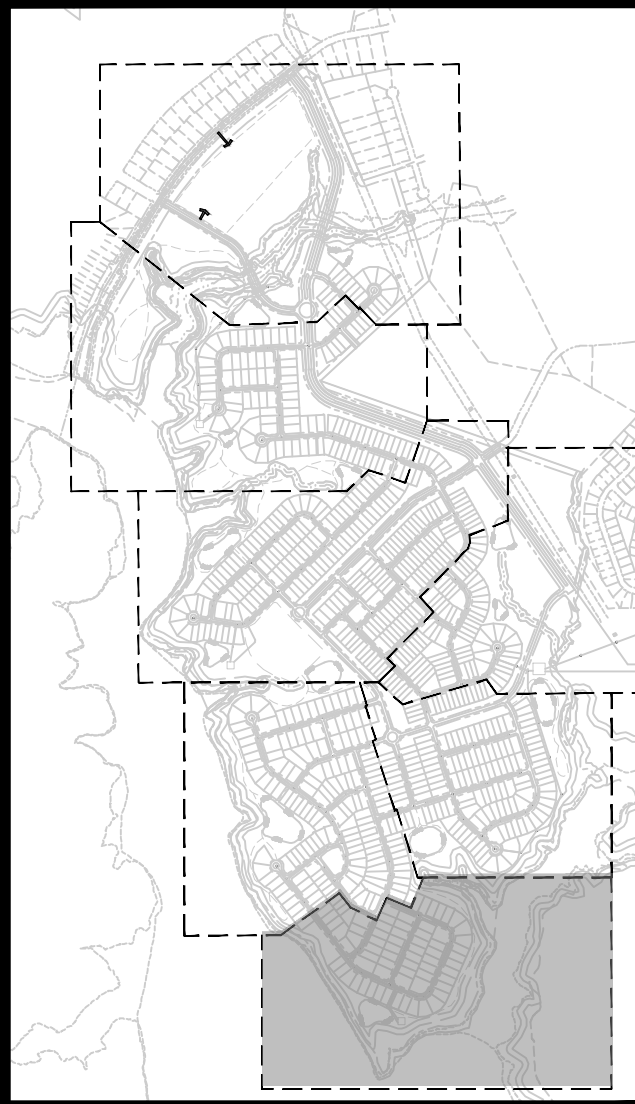

KEY MAP

LEGEND:

- 50' BUFFER ALONG 580' CONTOUR
- 100 YEAR FLOODPLAIN
- 30' STREAM & WETLAND BUFFER
- WETLANDS
- OPEN SPACE
- PERIMETER BUFFER

MATCHLINE - SEE SHEET 5

MATCHLINE - SEE SHEET 6

50' UNDISTURBED BUFFER ALONG 580' CONTOUR (TYP.)

SOUTH FORK RIVER

SOUTH FORK RIVER

SOUTH FORK RIVER

FLOODPLAIN (PER SURVEY)

PROP. WATER QUALITY AREA

PROP. TREE SAVE AREA

PROP. TREE SAVE AREA

30' STREAM AND WETLAND BUFFER (TYP.)
STREAM (PER REPORT)

PROP. TRAIL (TYP.)

PROP. SSWR MANHOLE (TYP.)
PROP. SSWR PIPE (TYP.)

PROP. SSFM PIPE (TYP.)
PROP. PUMP STATION (TYP.)

STREET EF
50' PUBLIC R/W

STREET GG
50' PUBLIC R/W

STREET DD
50' PUBLIC R/W

50' LAKE WYLE BUFFER (TYP.)

50' LAKE WYLE BUFFER (TYP.)

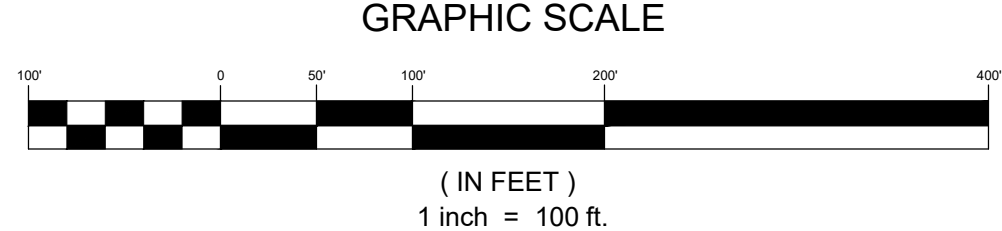

Know what's below.
Call before you dig.

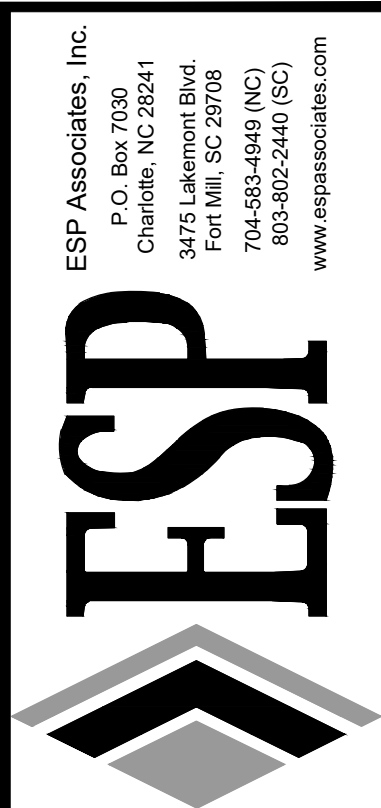

ESP Associates, Inc.
P.O. Box 7003
Charlotte, NC 28241
3475 Lakemont Blvd.
Fort Mill, SC 29708
704-583-0440 (NC)
803-502-2440 (SC)
www.espassociates.com

NO.	DATE	REVISION	BY

PROJECT INFORMATION
 PROJECT MANAGER: MM
 DESIGNED BY: AB
 DRAWN BY: SW
 PROJECT NUMBER: HN28.100
 ORIGINAL DATE: 06/05/2020
 SHEET:
7 OF 8

SOUTH FORK SITE
 CITY OF BELMONT, NORTH CAROLINA
 PULTE GROUP, INC.

U:\2019 Projects\HN28 - South Fork Site (Pulte)\X000\Sheet\HN28-SHEETS.dwg, SHEET 7, redson



ARCHITECTURAL NOTES:
 1. EXAMPLE ELEVATIONS AND CONCEPTUAL ARCHITECTURAL RENDERINGS ARE FOR ILLUSTRATIVE PURPOSES ONLY AND ARE SUBJECT TO CHANGE

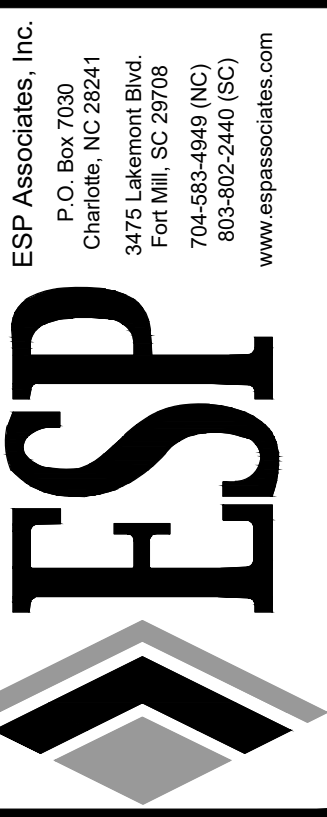

NO.	DATE	REVISION	BY

SCHEMATIC PLAN - ELEVATIONS
 (SHEET 8 OF 8)

SOUTH FORK SITE

CITY OF BELMONT, NORTH CAROLINA
 PULTE GROUP, INC.

PROJECT INFORMATION	
PROJECT MANAGER:	MM
DESIGNED BY:	AB
DRAWN BY:	SW
PROJECT NUMBER:	HN28.100
ORIGINAL DATE:	06/05/2020

SHEET:
8 OF 8