

**AGENDA- SPECIAL MEETING**  
**THE SUBCOMMITTEE OF THE PLANNING COMMISSION – ODDS PROJECT**  
**MONDAY, NOVEMBER 8, 2021, 9:00 AM**

**REMOTE MEETING**

***COVID – 19 ADVISORY NOTICE***

On March 3, 2020, Governor Newsom proclaimed a State of Emergency due to the COVID-19 pandemic that remains in effect. This meeting will be held remotely consistent with Executive Order N-29-20 and Assembly Bill 361, modifying provisions of the Brown Act to allow remote meetings at the current time. Members of the subcommittee and staff will participate in this meeting remotely. Members of the public are encouraged to participate remotely via Zoom or telephone pursuant to the information and link below. Public comment will be accepted during the meeting. The public may also submit comments in advance of the meeting by emailing the Director of Planning and Building at: [iborba@cityofbelvedere.org](mailto:iborba@cityofbelvedere.org). Please write “Public Comment” in the subject line. Comments submitted one hour prior to the commencement of the meeting will be presented to the subcommittee and included in the public record for the meeting. Those received after this time will be added to the record and shared with the subcommittee members after the meeting.

**City of Belvedere is inviting you to a scheduled Zoom meeting.**  
**Topic: Sub-Committee of the Belvedere Planning Commission – ODDS Project**  
**Time: Monday, November 8, 2021, 09:00 AM**

**Join Zoom Meeting**

<https://us02web.zoom.us/j/87351962365?pwd=K3hwV1p3Q2xyV1EyUDFMUjdDaHA3Zz09>

**Webinar ID: 873 5196 2365**

**Passcode: 921656**

**888 -788- 0099 (Toll Free)**

**877- 853- 5247 (Toll Free)**

The City encourages that comments be submitted in advance of the meeting. However, for members of the public using the Zoom video conference function, those who wish to comment on an agenda item should write “I wish to make a public comment” in the chat section of the remote meeting platform. At the appropriate time, the Meeting Host will allow oral public comment through the remote meeting platform. Any member of the public who needs special accommodations to access the public meeting should email the **Director of Planning and Building**, [iborba@cityofbelvedere.org](mailto:iborba@cityofbelvedere.org) who will use her best efforts to provide assistance.

---

**A. CALL TO ORDER THE SPECIAL MEETING OF THE SUBCOMMITTEE**

**B. STAFF UPDATE – Oral Report**

**C. SUBCOMMITTEE REVIEW/DISCUSSION OF CURRENT PUBLIC DRAFT OF ODDS (Objective Design & Development Standards)**

[ODDS PUBLIC DRAFT](#)

[ODDS ZONING MAP](#)

**D. ADJOURN**

**NOTICE: WHERE TO VIEW AGENDA MATERIALS**

Online at [www.cityofbelvedere.org](http://www.cityofbelvedere.org)

**Belvedere City Hall**, 450 San Rafael Ave, Belvedere (Writings distributed to the Planning Commission after the posting date of this agenda are available for public inspection at this location only);

**Belvedere-Tiburon Library**, 1501 Tiburon Boulevard, Tiburon.

To request automatic mailing of agenda materials, please contact the City Clerk at (415) 435-3838.

**NOTICE: AMERICANS WITH DISABILITIES ACT**

The following accommodations will be provided, upon request, to persons with a disability; agendas and/or agenda packet materials in alternate formats and special assistance needed to attend or participate in this meeting. Please make your request at the Office of the Planning Department or by calling (415) 435-3838. Whenever possible, please make your request four working days in advance of the meeting.

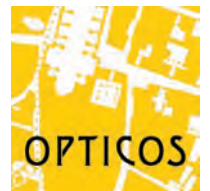
Items will not necessarily be heard in the above order, not, because of possible changes or extenuating conditions, be hear. For additional information, please contact City Hall, 450 San Rafael Ave, Belvedere CA 94920. (415) 435-3838.

Posted 11/3/2021



# Title 22: Objective Design and Development Standards

Public Review Draft  
October 27, 2021



*This page intentionally left blank*



# Table of Contents

<b>Preamble</b>		<b>1</b>
P-1A	Creating a Place-Based Foundation for Zoning	1
P-1B	Guiding Principles	1
P-1C	Classification of Different Context Types in Belvedere	2
P-1D	Summary of the Form-Based Zones in Belvedere	4
P-1E	A Hybrid Approach for Belvedere	4
P-1F	The Transect	10
<b>Chapter 1: Introduction</b>		<b>11</b>
22.01.010	Purpose	11
22.01.020	Applicability	11
22.01.030	Relationship to Belvedere General Plan	15
22.01.040	Relationship to Title 19 (Zoning)	16
<b>Chapter 2: Establishment of Zones</b>		<b>19</b>
22.02.010	Purpose	19
22.02.020	Zones Established	19
22.02.030	Sub-Zones	20
22.02.040	Zone Map	20
<b>Chapter 3: Zones</b>		<b>21</b>
22.03.010	Purpose	21
22.03.020	Overview of Zones	21
22.03.030	T3 Suburban Neighborhood (T3SN)	25
22.03.040	T4 Suburban Neighborhood.Small (T4SN.S)	29
22.03.050	T4 Suburban Main Street.Small (T4SMS.S)	33
<b>Chapter 4: Specific to Uses</b>		<b>37</b>
22.04.010	Purpose	37
22.04.020	Use Standards	37
22.04.030	Use Table	38

<b>Chapter 5: General to Design Sites</b>	<b>41</b>
22.05.010 Purpose	41
22.05.020 Screening	41
22.05.030 Landscaping and Lighting	44
22.05.040 Parking and Loading	46
22.05.050 Public Frontage Standards	53
22.05.060 Privacy Standards	56
<b>Chapter 6: Specific to Building Types</b>	<b>57</b>
22.06.010 Purpose	57
22.06.020 Building Types	57
22.06.030 Overview of Building Types	61
22.06.040 Carriage House	63
22.06.050 House	67
22.06.060 Duplex Side-by-Side	70
22.06.070 Duplex Stacked	75
22.06.080 Cottage Court	79
22.06.090 Fourplex	82
22.06.100 Neighborhood Townhouse	87
22.06.110 Neighborhood Courtyard	91
22.06.120 Pocket Neighborhood	95
22.06.130 Multiplex	100
22.06.140 Main Street Building	105

<b>Chapter 7:</b>	<b>Specific to Private Frontage Types</b>	<b>113</b>
22.07.010	Purpose	113
22.07.020	Private Frontage Types	113
22.07.030	Overview of Private Frontage Types	114
22.07.040	Porch Projecting	116
22.07.050	Porch Engaged	118
22.07.060	Dooryard	120
22.07.070	Stoop	122
22.07.080	Forecourt	124
22.07.090	Maker Shopfront	126
22.07.100	Shopfront	128
22.07.110	Terrace	130
22.07.120	Gallery	132
<b>Chapter 8:</b>	<b>Specific to Architectural Design</b>	<b>135</b>
22.08.010	Purpose	135
22.08.020	Applicability	135
22.08.030	Architectural Design Standards	135
22.08.040	Overview of Architectural Styles	135
22.08.050	Contemporary	139
22.08.060	Craftsman	151
22.08.070	East Coast Cottage	163
22.08.080	Main Street Classical	175
22.08.090	Mediterranean	185

<b>Chapter 9: Specific to Large Sites</b>	<b>197</b>
22.09.010 Purpose	197
22.09.020 General to Walkable Community Design	198
22.09.030 Walkable Neighborhood Plan	203
22.09.040 General to Civic Space	204
<b>Chapter 10: Administration</b>	<b>211</b>
22.10.010 Purpose	211
22.10.020 Procedures	211
22.10.030 Adjustments to Standards	225
<b>Chapter 11: Definitions</b>	<b>229</b>
22.11.010 Purpose	229
22.11.020 Definitions	229
22.11.030 Measurement Methods	263

*This page intentionally left blank*

# Quick Code Guide for Developments Less Than Two Acres

The following graphic is intended as a summary guide. Please refer to the procedures for applications eligible for streamlined review consistent with State Law [Section 22.10.020 (Procedures)] for all necessary information.

1

## Determine your Maximum Zoning Envelope<sup>1</sup>

<b>Identify your zone</b> , see Chapter 3 (Zones) and Belvedere Objective Design Standards Zones Map	a. Select your building type(s)	Subsection 3 of the zone
	b. Comply with building placement standards	Subsection 5 of the zone
	c. Comply with building form and height standards	Subsection 4 of the zone
	d. Select from allowed uses	Table 22.04.030.A (Uses)
	e. Comply with parking standards	Subsection 7 of the zone
	f. Select your private frontage type	Subsection 8 of the zone
<b>Identify your building type standards</b> , see Chapter 6 (Specific to Building Types)	a. Select your detailed massing type	Subsections 3 and 7 of the building type
	b. Comply with the standards	Subsections 1, 2, 4-7 of the building type

<sup>1</sup> Developments that propose multiple design sites shall apply this process for each design site.

2

## Connect Ground Floor to Adjacent Streetscape

<b>Apply your private frontage type(s)</b> , see Chapter 7 (Specific to Private Frontage Types)	Based on your selected private frontage type(s), comply with the standards	See Subsections of the private frontage type
---	--	--

3

## Design your Building

<b>Identify your architectural standards</b> , see Chapter 8 (Specific to Architectural Design)	Based on your selected detailed massing type, select your architectural style	Subsections 1-16 of the architectural style
---	---	---

# Quick Code Guide for Developments Less Than Two Acres (Continued)

## 4

### Proceed to Approval Process

<b>If adjustments are proposed</b> , see Section 22.10.030 (Adjustments to Standards)	Meet the required findings to be eligible for the adjustment to the standard(s)	Section 22.10.030 (Adjustments to Standards)
<b>Identify your approval procedure</b> , see Chapter 10 (Administration)	Comply with the procedure standards	Section 22.10.020 (Procedures)



# Quick Code Guide for Developments of at Least Two Acres

The following graphic is intended as a summary guide. Please refer to the procedures for applications eligible for streamlined review consistent with State Law [Section 22.10.020 (Procedures)] for all necessary information.

1

## Design your Walkable Neighborhood Plan (WNP)

<b>Apply the WNP design process,</b> see Subsection 22.09.020.1	Comply with the standards	Section 22.09.020 (General to Walkable Community Design)
<b>Prepare WNP</b>	Comply with the standards	Section 22.09.030 (Walkable Neighborhood Plan)

2

## Determine your Maximum Zoning Envelope

<b>Identify your zone(s),</b> see Chapter 3 (Zones) and Belvedere Objective Design Standards Zones Map	For each WNP:	Subsection 3 of the zone
	a. Select your building type(s)	
	b. Comply with building placement standards	Subsection 5 of the zone
	c. Comply with building form and height standards	Subsection 4 of the zone
	d. Select from allowed uses	Table 22.04.030.A (Uses)
	e. Comply with parking standards	Subsection 7 of the zone
<b>Identify your building type standards,</b> see Chapter 6 (Specific to Building Types)	f. Select your private frontage type for each building type	Subsection 8 of the zone
	a. Select your detailed massing type for each building type	Subsections 3 and 7 of the building type
	b. Comply with the standards	Subsections 1, 2, 4-7 of the building type

<sup>1</sup>This process shall be applied to each design site.

3

## Connect Ground Floor of each Building Type to Adjacent Streetscape

<b>Apply your private frontage types to each building type,</b> see Chapter 7 (Specific to Private Frontage Types)	Based on your selected building types, comply with the standards	See Subsections of the private frontage type
--	--	--

# Quick Code Guide for Developments at Least Two Acres (Continued)

4 Design your Buildings		
<b>Identify your architectural standards</b> , see Chapter 8 (Specific to Architectural Design)	Select your architectural style standards for each building type	Subsections 1-16 of the architectural style

5 Proceed to Approval Process		
<b>If adjustments are proposed</b> , see Section 22.10.030 (Adjustments to Standards)	Meet the required findings to be eligible for the adjustment to the standard(s)	Section 22.10.030 (Adjustments to Standards)
<b>Identify your approval procedure</b> , see Chapter 10 (Administration)	Comply with the procedure standards	Section 22.10.020 (Procedures)

*This page intentionally left blank*

# Preamble

---

## Sections:

P-1A	Creating a Place-Based Foundation for Zoning
P-1B	Guiding Principles
P-1C	Classification of Different Context Types in Belvedere
P-1D	Summary of the Form-Based Zones in Belvedere
P-1E	A Hybrid Approach for Belvedere
P-1F	The Transect

---

## P-1A Creating a Place-Based Foundation for Zoning

This Title 22 (Objective Design and Development Standards), shall hereafter be referred to as the Form-Based Code or "FBC". The FBC implements the City of Belvedere General Plan vision through the application of zones and standards that reflect a context-specific approach based upon Belvedere's distinct walkable development patterns. These patterns are described as walkable because of their interconnected streets and blocks; variety of housing choices; and proximity to services, shopping and/or transit. The FBC addresses the walkable development patterns, existing or intended, through standards consistent with Belvedere's General Plan.

---

## P-1B Guiding Principles

The FBC is guided by the following principles in implementing the Belvedere General Plan:

1. Across the City, the FBC:
  - A. Provides clear and effective development standards that allow for streamlined review processes and the predictable production of housing;
  - B. Supports a diversity of housing choices appropriate to their location;
  - C. Ensures appropriately-scaled infill development;
  - D. Reinforces and enhances community design and character in support of the community's vision with: a variety of neighborhoods; main street areas as the cultural and commercial heart of the community; and neighborhoods with centers along pleasant and convenient corridors that interconnect the City;
  - E. Removes barriers to revitalization and reinvestment through clear, objective, and context-sensitive standards;
  - F. Ensures that each building plays a role in creating a better whole, not just a good building; and
  - G. Promotes development patterns that support safe, effective, and multi-modal transportation options for all users and help reduce greenhouse gas emissions.

2. Within community cores, the FBC:
  - A. Reinforces the main street as a cultural and commercial destination accommodating appropriately-scaled infill housing, mixed-use, and cultural development compatible with existing historic buildings; and
  - B. Facilitates transitions from single-use areas to mixed-use employment centers that are compatible with adjacent residential neighborhoods and public access.
3. Within residential neighborhoods in core, suburban, and edge contexts, the FBC:
  - A. Protects the character of established neighborhoods and builds upon and reinforces the unique physical characteristics of the City's walkable neighborhoods;
  - B. Supports new walkable neighborhood patterns through new networks of well-designed multi-modal streets that are safe for pedestrians and cyclists; and
  - C. Promotes neighborhoods with quality housing and diverse, context-sensitive housing choices.
4. Along corridors within core, suburban, and edge contexts, the FBC:
  - A. Promotes a variety of housing choices;
  - B. Promotes small local businesses as an important part of the City's economy;
  - C. Promotes incremental infill and revitalization;
  - D. Reinforces neighborhood main streets as centers to continue as vibrant social and commercial focal points, with services and amenities for the surrounding neighborhoods located within a safe, comfortable walking distance of homes;
  - E. Balances pedestrian comfort and place-making with traffic efficiency; and
  - F. Promotes and accommodates high-quality community design.

---

## P-1C Classification of Different Context Types in Belvedere

Belvedere is characterized by different context types that reflect its pre- and post-World War II development patterns. Historic districts and neighborhoods developed prior to WWII tend to be more pedestrian-oriented, with smaller blocks, consistent sidewalks, more integrated development patterns with services, shopping and/or transit within short walking distance. Newer areas of the City, by comparison, tend to be more auto-oriented, with larger blocks and less amenities within short walking distance.

The FBC applies a context-sensitive approach to the City that is based upon the classification of three broad context types: Natural, Walkable, and Auto-Oriented Suburban. Each needs to be regulated differently to effectively reinforce the intended context. Figure P-1C-1 (Context Type Descriptions) provides full descriptions of each context type.

Within each of these broad contexts, the FBC further articulates context through three types of areas across the City: areas at or near the core, suburban areas, and areas at the edge of the community. In order to make as direct a connection as possible between the context-sensitive approach and the standards, this physical structure is carried through into the names of the form-based zones in this FBC.

**Figure P-1C-1: Context Type Descriptions**

### Natural Context

The Natural Context Type consists of land not intended for development. In these areas, nature dominates a person's experience, but may include an occasional recreation-oriented or utility building or other man-made feature. The use of cars occurs, but does not dominate the physical character.

These areas are implemented through conventional, use-based zones.



### Auto-Oriented Suburban Context

The Auto-Oriented Suburban Context Type consists of areas developed mainly after the 1950's. This type of development is driven by the priority to accommodate the automobile. Characteristic of this context type, land uses are segregated and often buffered, leaving large distances between them contributing to the need for the automobile for day-to-day functions. Walking and cycling occur in these areas, but generally for recreational rather than destination purposes due to low connectivity and few amenities within short walking distance.

Examples of these areas are commercial big box retail, strip mall centers, single-unit residential subdivisions, and industrial areas.

These areas are implemented through conventional, use-based zones.



### Walkable Context

The Walkable Context Type consists of areas where a person can walk, bike or ride transit to work to fulfill most shopping and recreation needs. These areas allow for but do not require the use of a vehicle to accommodate most daily needs.

These areas, primarily developed prior to the 1940's, were developed in a pattern where a person can live with limited reliance on the automobile. Today, these areas are still conducive to destination walking and cycling. These areas are supported through a network of interconnected, tree-lined streets, a diversity of housing choices, and a mix of appropriate commercial and residential uses in a compact form. These areas also support public transit due to their compact nature.

These areas are implemented through the T3-T5 form-based zones.



---

## P-1D Summary of the Form-Based Zones in Belvedere

The FBC implements Belvedere's General Plan through the transect. The transect applies to Natural, Rural, and Walkable Contexts as illustrated in Table P-1E-B (Summary Table of Transects for Natural, Rural, and Walkable Contexts in Belvedere). These contexts are implemented through the form-based zones identified in Table P-1F-A (Belvedere Transect). See Chapter 3 (Zones) for details of each zone.

---

## P-1E A Hybrid Approach for Belvedere

In zoning, a *hybrid* zoning code brings together the zoning and operating systems of form-based zoning and conventional, use-based zoning to address the unique qualities of all context types that make up a community. Form-based zoning is applied to Walkable Contexts, and conventional, use-based zoning is applied to Natural and Auto-Oriented Suburban Contexts.

This hybrid approach directs development and uses within each context type to thrive with standards that respond to the unique needs and community objectives of each context. For example, a neighborhood main street is regulated through form-based zoning with the intention that the standards will generate walkable development. Standards generate buildings that are scaled to the pedestrian and to existing and future neighboring buildings, and are placed to shape a public realm for pedestrians. Uses are regulated but are a lower priority than the overall physical environment and public realm that the uses occupy.

A suburban strip mall is regulated through conventional, use-based zoning with the intention that the standards will generate Auto-Oriented Suburban development. Standards control uses, overall heights and intensities with less priority as to their exact placement on a design site or how each building shapes the public realm. In cases where the intent is to transform Auto-Oriented Suburban development (e.g., retrofit of suburban strip mall) to walkable development, form-based zoning best implements those transformations.

The addition of this FBC to the City's zoning code makes the zoning code a hybrid code. In this hybrid approach, the FBC is applied only to areas where walkable development exists or is desired. Conventional, use-based zones and standards continue to apply to Natural and Auto-Oriented Suburban development.



## 1. What is a Form-Based Code?

Form-Based Coding (FBC) represents a paradigm shift in the way that the built environment is regulated. The formal short definition of a FBC is as follows:

*Form-Based Codes foster predictable built results and a high-quality public realm by using physical form (rather than separation of uses) as the organizing principle for the code. These codes are adopted into city or county law as regulations, not mere guidelines. Form-Based Codes are an alternative to conventional zoning.*

*-Form-Based Codes Institute*

Unlike conventional, use-based codes, FBCs utilize the intended form and character, rather than use as the organizing framework of the code. This FBC is informed by the three physical context types described in Section P-1C (Classification of Different Context Types in Belvedere) to implement the key characteristics that comprise the physical character of different areas (place types) documented across the community. Further, FBCs regulate a series of important elements not just to create a good individual building, but a high-quality place. The terminology in FBCs reflects the intended physical form and hierarchy of different places. For example, instead of a zone being labeled "commercial" or "mixed use," it might be called "main street." The term "main street" ties back to the intended physical form or place, which includes a mix of uses, civic spaces, streets, frontages, and building types that create vibrant walkable urbanism.

It is also important to note that while FBCs primarily regulate the intended physical form, they regulate use secondarily. FBCs allow a range of uses that are carefully chosen to maximize compatibility between uses and the intended physical form of the zone. The use-tables in a FBC are simplified and categorized by use-type, and clearly defined, to allow a greater degree of administrative decision-making related to particular uses.

## 2. The Natural-to-Urban Transect: The Framework for the Form-Based Code

Most FBCs use an organizing principle called the Natural-to-Urban Transect, see Figure P-1E-1 (Transect Diagram). This enables a customized framework of zones for a community that are based on intended physical character.

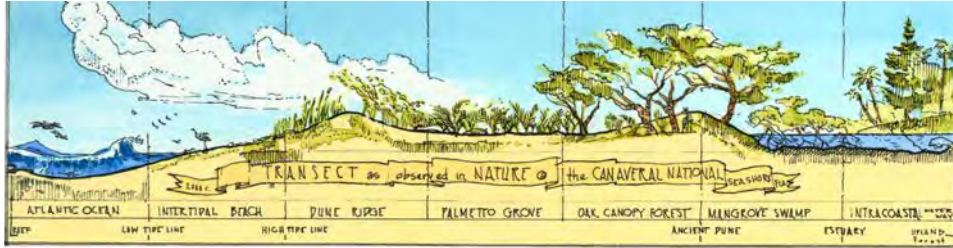
The transect establishes a hierarchy of physical environments or transects from the most natural to the most urban. The designation of each transect along this hierarchy is determined first by the character and form, intensity of development, and type of place, and secondly by the mix of uses within the area. This hierarchy of physical environments becomes the framework for the entire FBC, replacing use as the organizing principle as in conventional, use-based zoning. Each transect is used to reinforce existing or create new walkable environments.

*The Natural-to-Urban Transect is a means for considering and organizing the human habitat in a continuum of intensity that ranges from the most natural condition to the most urban. It provides a standardized method for differentiating between the intentions for urban form in various areas using gradual transitions rather than harsh distinctions. Each transect is primarily classified by the physical intensity of the built form, the relationship between nature and the built environment, and the complexity of uses within the transect.*

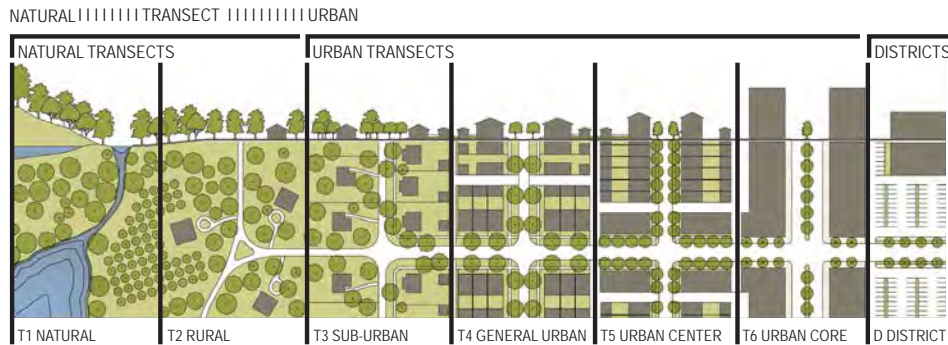
*~ Form-Based Codes Institute*

**Figure P-1E-1: Transect Diagram**

A Natural Transect diagram illustrates a continuum of Natural Context Types from the ocean shore inland from left to right. Image courtesy of DPZ.



The Natural-to-Urban Transect diagram illustrates a continuum of context types from the most natural to the most urban from left to right. Image courtesy of DPZ.



The model transect for American communities is divided into six individual transects and a Special District as shown in Table A (Model Transect for American Communities). Each transect is given a number. Higher numbers designate progressively more urban zones, and lower numbers designate less urban and natural zones. The City’s form-based zones are customized based on this framework.

**Table P-1E-A: Model Transect for American Communities**

Transect	Description
T1 - Natural	Lands approximating or reverting to a wilderness condition, including lands unsuitable for settlement due to topography, hydrology or vegetation
T2 - Rural	Sparsely settled lands in open or cultivated state, including woodland, agricultural land, and grassland
T3 - Walkable Neighborhood	Primarily residential with mix of lower intensity building types
T4 - General Urban or Walkable Neighborhood	Primarily residential with mix of moderate intensity building types and some lower intensity centers
T5 - Downtown Center	Higher intensity neighborhoods and higher intensity downtown centers - Not Applicable
T6 - Downtown Core	Regional-serving downtown - Not Applicable
D - District	Designation for areas with specialized purposes (e.g., heavy industrial, transportation, harbors, airports or university districts, among other possibilities)

*This page intentionally left blank*



Table P-1E-B: Summary Table of Transects for Natural, Rural, and Walkable Contexts in Belvedere

◀ Less Urban













Natural	Rural	Walkable Contexts
<p>T1</p>  <p>Source: Google Images</p>	<p>T2</p>  <p>Source: Google Images</p>	<p>T3 Walkable Neighborhood</p>  <p>Source: Google Images</p>
		
		
		

Table P-1E-B: Summary Table of Transects for Natural and Walkable Contexts in Belvedere (Continued)

More Urban 

Walkable Contexts

T4 Walkable Neighborhood      T5 Downtown Center      T6 Downtown Core



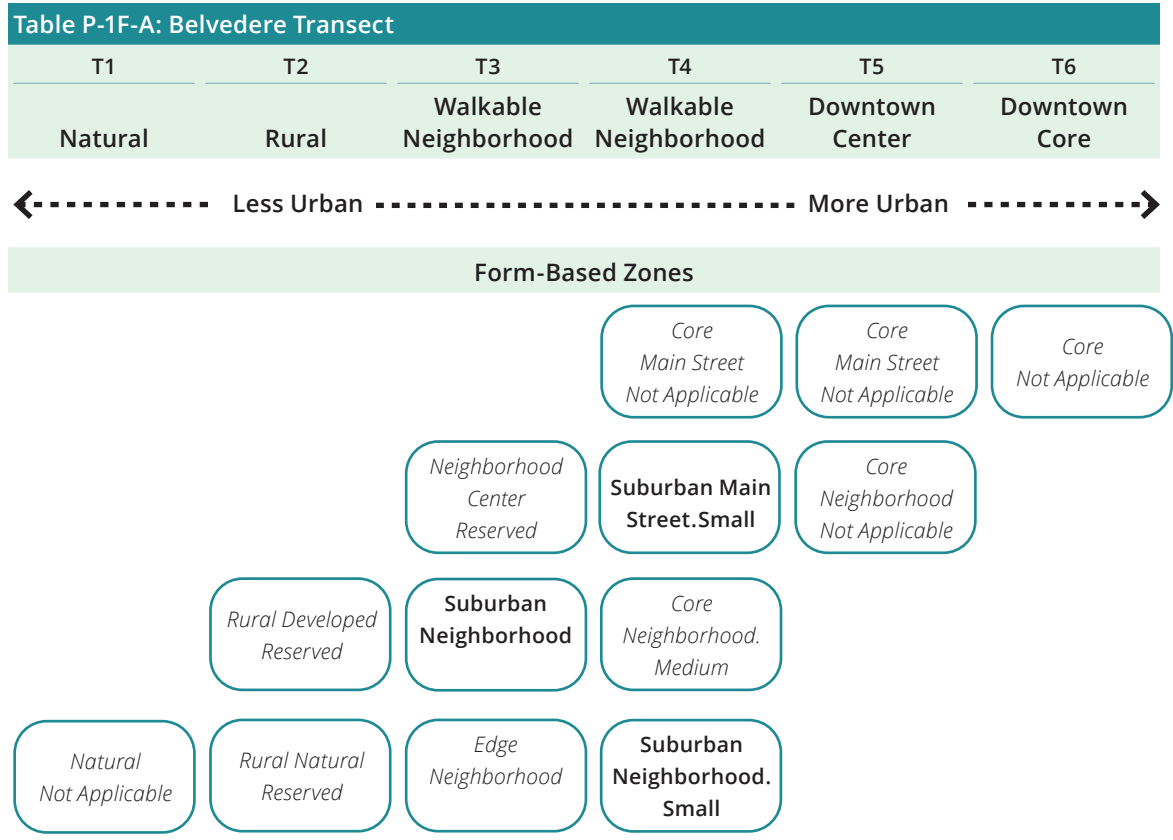
Not Applicable

Not Applicable



**P-1F The Transect**

Table A (Belvedere Transect) identifies the transects and the form-based zones that implement each transect. Belvedere's transect includes two of the six individual transects. The form-based zones needed to implement Belvedere's transect are identified in bold text.



A zone identified as *reserved* denotes a future zone and standards that will need to be prepared when the FBC is applied to areas needing that zone.



# Chapter 1: Introduction

---

## Sections:

22.01.010	Purpose
22.01.020	Applicability
22.01.030	Relationship to Belvedere General Plan
22.01.040	Relationship to Title 19 (Zoning)

---

## 22.01.010 Purpose

This Form-Based Code (FBC) sets forth the standards for neighborhood design, building form, and uses within form-based zones. These standards reflect the community's vision for implementing the intent of the Belvedere General Plan to facilitate housing production and specifically infill housing production, through development that reinforces the highly valued character and scale of the City's walkable centers, neighborhoods, and corridors.

---

## 22.01.020 Applicability

1. **Rules for Construction of Language.** The following general rules for construction of language apply to the text of this FBC:
  - A. **Tenses and Numbers.** Words used in the present tense include the future, words used in the singular include the plural, and the plural includes the singular, unless the context clearly indicates the contrary.
  - B. **Applicable.** The applicable standards of this FBC apply so as to not require stating the phrase "and all applicable standards" throughout this FBC.
  - C. **Conjunctions.** Unless the context clearly indicates otherwise, the following conjunctions shall be interpreted as follows:
    - (1) "And" indicates that all connected items or provisions apply;
    - (2) "Or" indicates that the connected items or provisions may apply; and
    - (3) "Either/or" indicates that the connected items or provisions apply singly but not in combination.
2. In areas subject to this FBC, the standards in this FBC prevail unless stated otherwise.



3. This FBC applies to proposed development as identified in Table A (Applicability).

<b>Table 22.01.020.A: Applicability</b>			
<b>Development Type</b>	<b>Housing Accountability Act (HAA) Applies<sup>1</sup></b>	<b>Senate Bill 330 Applies<sup>1</sup></b>	<b>Senate Bill 35 Applies<sup>2</sup></b>
<b>Single-Unit House</b>	No	No	No
<b>Transitional Housing</b>	Yes	Yes	See Multi-Family Housing (2 or more residential units)
<b>Supportive Housing</b>	Yes	Yes	
<b>Emergency Shelter</b>	Yes	Yes	
<b>Farmworker Housing</b>	Yes	Yes	
<b>Multi-Family Housing (2 or more residential units)</b>			
Affordable	Yes	Yes	Yes
Market Rate <sup>3</sup>	Yes	Yes	No
<b>Mixed-Use Development (at least 2/3 of square footage designated for residential units)</b>			
Affordable	Yes	Yes	Yes
Market Rate <sup>3</sup>	Yes	Yes	No
<b>Other Development</b>			
Non-Mixed-Use <sup>4</sup>	No	No	No
Non-Residential	No	No	No

<sup>1</sup> See Government Code §65589.5 for additional eligibility criteria and specific protections by development type.

<sup>2</sup> See Government Code §65913.4(a) for additional eligibility criteria (e.g., site standards, affordability provisions, and labor provisions).

<sup>3</sup> "Market Rate" refers to projects that do not contain the minimum percentage of affordable housing units to be eligible for Senate Bill 35 streamlining. See Footnote 2.

<sup>4</sup> Less than 2/3 of square footage designated for residential units.

4. As required by Table A (Applicability), the standards in this FBC apply to all proposed development and improvements within form-based zones ("zones") as identified below.

**A. General**

- (1) From the allowed types in the zone, and in compliance with the listed standards, the following shall be selected for each design site:
  - (a) Only one building type per design site is allowed, except a carriage house may be included within a design site in addition to the primary building type. Parcels with enough land area to meet the zone standards for minimum design site width and depth may have multiple building types;
  - (b) At least one private frontage type; and
  - (c) At least one use type.
- (2) Building types and private frontage types not listed in the zone's standards are not allowed in that zone.

- (3) Uses
    - (a) Comply with Chapter 4 (Specific to Uses); and
    - (b) Use types not listed in Table 22.04.030.A (Uses) are not allowed in that zone.
  - (4) New buildings and their improvements are subject to the City's local standards for Fire Safety and Building Safety.
  - (5) The City's standards for Accessory Dwelling Units (ADU) and Junior Accessory Dwelling Units (JADU) apply; see Chapter 19.79 (Accessory Dwelling Units and Junior Accessory Dwelling Units).
- B. **Site Standards.** Chapter 5 (General to Design Sites)
- (1) **Screening.** The standards of Section 22.05.020 (Screening) apply to the following:
    - (a) All new development; and
    - (b) Improvements to existing development.
  - (2) **Landscaping and Tree Standards.** The standards of Section 22.05.030 (Landscaping and Lighting) apply to the following:
    - (a) New primary building(s); and/or
    - (b) Site improvements to existing development.
  - (3) **Parking and Loading.** The standards of Section 22.05.040 (Parking and Loading) apply to the following:
    - (a) New development;
    - (b) Changes in land use; and/or
    - (c) Changes in intensity of buildings or structures made after the effective date of this FBC that cause an increase or decrease of 25 percent or greater in:
      - i. Gross floor area;
      - ii. Seating capacity;
      - iii. Units; and/or
      - iv. Parking spaces.
  - (4) **Public Frontage Standards.** The standards of Section 22.05.050 (Public Frontage Standards) apply to existing and proposed streets, in any of the following situations:
    - (a) New primary building(s);
    - (b) Addition(s) over 50 percent of the existing floor area of primary building;
    - (c) Facade renovation(s) to primary building along front or side street; and/or
    - (d) New block(s).

- (5) Privacy Standards. The standards of Section 22.05.060 (Privacy Standards) apply to existing and proposed streets, in any of the following situations:
  - (a) New primary building(s);
  - (b) Addition(s) over 50 percent of the existing floor area of primary building; and/or
  - (c) Facade renovation to primary building along interior side design site line.
- C. **Building Type Standards.** The standards of Chapter 6 (Specific to Building Types) apply to the following:
  - (1) New buildings (except public safety buildings); and
  - (2) Additions (except public safety buildings).
- D. **Private Frontage Type Standards.** The standards of Chapter 7 (Specific to Private Frontage Types) apply to the following:
  - (1) New buildings;
  - (2) Building facade renovation facing a street or civic space (except public safety buildings);
  - (3) Private property improvement along front or side street; and
  - (4) Modification of pedestrian entrance(s) along front or side street.
- E. **Architectural Design Standards.** The standards of Chapter 8 (Specific to Architectural Design) apply to the following:
  - (1) New buildings; and
  - (2) Building facade renovations that propose a change to any of the following: wall finishes, window trim finishes, roof materials, size of opening(s), architectural detail(s). The standards of Chapter 8 (Specific to Architectural Design) shall only apply to those elements being changed (except public safety buildings).
- F. **Walkable Community Design**
  - (1) **New Development.** New development on a design site of at least three acres or at least 700 feet long or deep is required to be designed in compliance with Chapter 9 (Specific to Large Sites).
  - (2) **Blocks and Streets**
    - (a) Development sites larger than three acres or at least 700 feet long or deep shall be divided into new blocks in compliance with Subsection 22.09.020.6.
    - (b) New streets are required to form blocks in compliance with Table 22.09.020.A (Block Size Standards).
    - (c) When designing a new street or retrofitting an existing street, the standards in Section 18.12.060 (Streets and Other Public Ways—Minimum Requirements) apply.

- (3) **Design Sites**
  - (a) New buildings are required to be designed in compliance with the design site width and depth standards of the zone.
  - (b) This FBC does not require the recordation of design site lines. The design site width and depth standards are for the purpose of consistently achieving pedestrian-oriented and scaled buildings.
- (4) **Civic Space Type Standards.** Development sites larger than two acres are required to create new civic space(s) in compliance with the standards of Chapter 9 (Specific to Large Sites) and Section 22.09.040 (General to Civic Space).
- G. **Street Standards.** The standards of Section 18.12.060 (Streets and Other Public Ways—Minimum Requirements) apply to the following:
  - (1) The construction of a new street and/or when an application for a Walkable Neighborhood Plan (WNP) is proposed.
  - (2) Existing street(s):
    - (a) Improvement or modification to curb return, pedestrian crossing, landscaping, or sidewalk;
    - (b) Improvement or modification to on-street parking, or lane striping; and/or
    - (c) Improvement or modification to right-of-way.
- H. **Nonconforming Situations.** The standards of Chapter 19.76 (Nonconforming Uses and Structures and Sites) apply to all nonconforming situations.
- I. **Procedures.** Applications for development are to be processed in compliance with the procedures identified in Section 22.10.020 (Procedures). Requests for administrative relief are to be processed in compliance with the procedures in Section 22.10.020 (Procedures) and the required findings in Section 22.10.030 (Adjustments to Standards).

---

## 22.01.030 Relationship to Belvedere General Plan

This FBC implements the City's General Plan vision through a palette of form-based zones described in Chapter 2 (Establishment of Zones). This FBC is applied to walkable environments, existing or new. Walkable is described as an environment that is pedestrian-oriented in nature, with a variety of housing choices, where bicycling and walking are viable daily options because services, retail, or restaurants are within 2,000 linear feet of most residences in the development.

## 22.01.040 Relationship to Title 19 (Zoning)

Table A [Relationship of Title 22 (Objective Design and Development Standards) to Title 19 (Zoning)] identifies the relationship of Title 22 (Objective Design and Development Standards) to Title 19 (Zoning) only for parcel(s) mapped with form-based zones subject to Title 22 (Objective Design and Development Standards). All other content in Title 19 (Zoning) not identified in the table continue to apply.

**Table 22.01.040.A: Relationship of Title 22 (Objective Design and Development Standards) to Title 19 (Zoning)**

Title 19 (Zoning)		Title 22 (Objective Design and Development Standards)
Chapter	Description	Status
19.08	Definitions	Replaced by Chapter 11 (Definitions) except as noted otherwise
19.20; 19.28; 19.36; and 19.40	R Zone; R-2 Zone; R-3 Zone; and C-1 Zone	
Sections 010 to 030	Permitted Uses; Uses Permitted Under Permit; and Prohibited Uses	Replaced by Table 22.040.030.A (Uses)
Section 040	Development Standards	
	Minimum Lot Size, Lot Width, and Lot Frontage	Replaced by Subsection 3 of the zone
	Lot Area/Unit	Not Applicable
	Setbacks (Front Yard, Side Yard, Rear Yard, Conditional Use)	Replaced by Subsection 5 of the zone
	Maximum Lot Coverage	Replaced by Subsection 3 of the building type
	Maximum Height	Replaced by Subsection 4 of the zone
	Usable Open Space	Replaced by Subsection 6 of the building type
	Off-street Parking	Amount, location and size of parking replaced by this Title in Subsection 7 of the zone and Section 22.05.040 (Parking and Loading)
Section 050	Design Review Required	Replaced by Table 22.01.020 A (Applicability) and Chapter 10 (Administration)
Section 040 of C-1 Zone	Development Standards	Replaced by this Title
19.44	Lot Area, Width and Frontages	
Section 19.44.030	R-2, R-3C and R-3 Zone Requirements	Replaced by Subsection 3 of the zone
Section 19.44.040	Exceptions to Minimum Area Requirements	Replaced by Table 22.10.030.A (Adjustments to Standards for Design Sites Less Than 6% Slopes)
Section 19.44.050	Calculation of Average Width	Replaced by definition of Design Site Width in Chapter 11 (Definitions)
Section 19.44.060	Frontages	Replaced by definition of Frontage in Chapter 11 (Definitions)

**Table 22.01.040.A: Relationship of Title 22 (Objective Design and Development Standards) to Title 19 (Zoning) (Cont'd)**

<b>Title 19 (Zoning) Chapter</b>	<b>Description</b>	<b>Title 22 (Objective Design and Development Standards) Status</b>
19.48	Yards and Setbacks	
Section 19.48.010	Yards and Setbacks—Requirements Generally	Replaced by Subsection 5 and 6 of the zone
Sections 19.48.020; 19.48.060; 19.48.070; 19.48.080; 19.48.110; 19.48.150; 19.48.170; and 19.48.180	Front Yards—Requirements Generally; Front Yard Setbacks—All Other Residential Zones; Front Yard Setbacks—C-1 Zone; Front Yard Setbacks—R Zone; Side Yards—Requirements Generally; Side Yards—R-2 and R-3 Zones; Rear Yards—All Zones; Additional Requirements for Churches, Public Buildings, Club Buildings, Nursery Schools and Preschools in Residential Zones	Replaced by Subsection 5 of the zone
Section 19.48.100	Encroachments on Easement or City Property—Permit or Revocable License Required	Replaced by Subsection 6 of the zone
Section 19.48.105	Parking Spaces Near Sidewalks	Replaced by Subsection 22.05.040.8 and Section 22.05.050 (Public Frontage Standards)
Section 19.48.130	Side Yards—R-1C and C-1 Zones	Replaced by Subsection 5 of the zone for C-1 Zones
19.52	Density and Open Space Requirements	
Sections 19.52.010; 19.52.020; 19.52.060; 19.52.070; and 19.52.120	Lot Coverage—Requirements Generally; Measurement of Lot Coverage; Lot Coverage—R-2, R-3C, and R-3 Zones; Lot Coverage—C-1 Zone; Floor Area—Exceptions Permitted When	Replaced by Subsection 5 of the zone and Subsection 3 of the building type
Section 19.52.130	Density and Open Space—R-2, R-3C, and R-3 Zones—Requirements Generally	Replaced by Subsection 6 of the building type
Section 19.52.140	Minimum Area for Each Apartment—R-2, R-3C, and R-3 Zones	Not applicable
Section 19.52.150	Minimum Usable Open Space—R-2, R-3C, and R-3 Zones	Replaced by Subsection 6 of the building type
Section 19.52.160	Implementation of State Density Bonus Law	Title 22 defers to State Law

**Table 22.01.040.A: Relationship of Title 22 (Objective Design and Development Standards) to Title 19 (Zoning) (Cont'd)**

Title 19 (Zoning)		Title 22 (Objective Design and Development Standards)
Chapter	Description	Status
19.56	Height Limits	
Section 19.56.010	Restrictions Generally and Applicability of Height Limits	Replaced by Subsection 4 of the zone
Section 19.56.020	R-3 and C-1 Zone Limitations	Maximum height of 36' applies including State Density Bonus
Sections 19.56.040; 19.56.050; and 19.56.080	R-1L and R-2 Zone Limitations; Limitations in All Other Residential Zones; R-1L and R-2 Zones— Exceptions Permitted When	Replaced by Subsection 4 of the zone
Section 19.56.090	Calculation of Average Height (Emmons' Law)	Replaced by Subsection 22.11.030.2.A.(5)
19.60	Building Requirements	
Section 19.60.010	Design Review Approval Prerequisite to Permit Issuance	Applies as identified in Section 22.10.020 (Procedures)
Section 19.60.020	Compliance with Requirements	Replaced by Subsections 2 through 8 of the Zone
Section 19.60.030	Number of Main Buildings Permitted	Replaced by Subsection 22.06.020.5
19.64	Streets and Private Ways	
Section 19.64.010	Street Widths in the C-1 Zone	Section 22.05.050 (Public Frontage Standards) applies in addition to Section 19.64.010 (Street Widths in the C-1 zone)
19.68	Off-Street Parking	
Sections 19.68.020; 19.68.030; 19.68.050; and 19.68.070	Number and Type of Spaces Required; Tandem Parking— Defined—How Treated; Building Restrictions; and Compact Spaces Permitted	Replaced by Section 22.05.040 (Parking and Loading)
Section 19.68.080	Handicapped Spaces	Title 22 defers to Federal/State standards



# Chapter 2: Establishment of Zones

---

**Sections:**

- 22.02.010 Purpose
- 22.02.020 Zones Established
- 22.02.030 Sub-Zones
- 22.02.040 Zone Map

---

## 22.02.010 Purpose

This Chapter establishes the palette of form-based zones ("zones") to implement the Belvedere General Plan, and its transect as described in the Preamble of this FBC. The zones are for the purpose of generating and supporting the variety and physical character of existing and new walkable environments.

---

## 22.02.020 Zones Established

This Section identifies the zones, based on the intended physical form and character of the environments described in the Preamble of this FBC. These zones focus on mixed-use, walkable environments and range in function and intensity from primarily residential areas with a mix of lower intensity building types (T3 Suburban Neighborhood), to moderate intensity neighborhoods (T4 Suburban Neighborhood.Small), and moderate-intensity centers (T4 Suburban Main Street.Small).

---

### 22.02.030 Sub-Zones

1. Sub-zones are slight variations of the base zone (e.g., T4 Suburban Neighborhood.Small), are design site-specific, and mapped on the Belvedere Objective Design Standards Zones Map. The FBC includes two types of sub-zones:
  - A. **Open.** The open sub-zone is applied for either or both of the following purposes:
    - (1) To allow more uses than the base zone allows in specific areas but within the same form and character of the base zone (e.g., T4 Suburban Neighborhood.Small), except that additional frontages are allowed within the same form and character of the base zone; and/or
    - (2) To more easily allow certain uses that are already allowed in the base zone. In this way, the open sub-zone can provide additional flexibility to design sites located at or near intersections that function or are intended to function as a neighborhood node of non-residential uses.
  - B. **Limited.** The limited sub-zone is applied for either or both of the following purposes:
    - (1) To allow less uses than the base zone allows in specific areas, within the same form and character of the base zone; and/or
    - (2) To further restrict certain uses already allowed in the base zone for specific areas.
2. Table 22.04.030.A (Uses) identifies the sub-zones and its standards for the particular uses.

---

### 22.02.040 Zone Map

The zones established in this Section are mapped on the Belvedere Objective Design Standards Zones Map.

# Chapter 3: Zones

---

## Sections:

22.03.010	Purpose
22.03.020	Overview of Zones
22.03.030	T3 Suburban Neighborhood (T3SN)
22.03.040	T4 Suburban Neighborhood.Small (T4SN.S)
22.03.050	T4 Suburban Main Street.Small (T4SMS.S)

---

## 22.03.010 Purpose

This Chapter provides zones and standards to implement the Belvedere General Plan to generate and support the variety of physical character of the intended development.

---

## 22.03.020 Overview of Zones

Table A (Zones Overview) provides an overview of each zone and its intent. This information is to show how the broader transects in Table P-1F-A (Belvedere Transect) have been applied, and as qualitative background information on the intended physical character, allowed range of uses, and direction for the detailed standards in each zone.

**Table 22.03.020.A: Zones Overview**

**Less Urban**

**T3 Suburban Neighborhood 22.03.030**



**Zone Abbreviation**

T3SN

**Sub-Zone(s)**

None

**Intent**

A walkable neighborhood environment of small-to-medium footprint, low-to-moderate-intensity housing choices, supporting and within short walking distance of neighborhood-serving retail and services.

**Desired Form**

House-Scale Buildings  
 Primarily Detached Buildings  
 Small-to-Medium Building Footprint  
 Small-to-Medium Front Setbacks  
 Small-to-Medium Side Setbacks  
 Up to 2.5 Stories without Bonus; Up to 3 Stories with Bonus House, Duplex Side-by-Side, Cottage Court, Fourplex, Neighborhood Townhouse, and Pocket Neighborhood  
 Porch Projecting, Porch Engaged, and Dooryard Frontage Types

**T4 Suburban Neighborhood.Small 22.03.040**



**Zone Abbreviation**

T4SN.S

**Sub-Zone(s)**

T4SN.S-Open. The open sub-zone allows more uses and additional frontages within the same form and character of the base zone.

**Intent**

A walkable neighborhood environment of small-to-medium footprint, moderate-intensity housing choices, supporting and within short walking distance of neighborhood-serving retail and services.

**Desired Form**

House-Scale Buildings  
 Primarily Detached Buildings  
 Small-to-Medium Building Footprint  
 Small-to-Medium Front Setbacks  
 Small-to-Medium Side Setbacks  
 Up to 2.5 Stories without Bonus; up to 3 Stories with Bonus House, Duplex Stacked, Cottage Court, Fourplex, Neighborhood Townhouse, Neighborhood Courtyard, Pocket Neighborhood, and Multiplex  
 Porch Projecting, Porch Engaged, Dooryard, and Stoop Frontage Types; Shopfront in Open Sub-Zone

Table 22.03.020.A: Zones Overview (Continued)

More Urban 

**T4 Suburban Main Street.Small 22.03.050**



**Zone Abbreviation**

T4SMS.S

**Sub-Zone(s)**

T4SMS.S-Open. The open sub-zone allows more uses and additional frontages, within the same form and character of the base zone.

**Intent**

A walkable, vibrant district of small-to-medium footprint, moderate intensity, mixed-use buildings and housing choices, supporting neighborhood-serving ground floor retail, food and services.

**Desired Form**

Primarily House-Scale Buildings

Primarily Attached Buildings

Small-to-Medium Building Footprint

None-to-Small Front Setbacks

None-to-Small Side Setbacks

Up to 2.5 Stories without Bonus; up to 3 Stories with Bonus

House, Neighborhood Townhouse, Neighborhood Courtyard, Multiplex, and Main Street Building

Porch Projecting, Porch Engaged, Forecourt, Shopfront, Terrace, and Gallery Frontage Types; Dooryard, Stoop, and Maker Shopfront Frontage Types in Open Sub-Zone or on Side Street

*This page intentionally left blank*



**22.03.030 T3 Suburban Neighborhood (T3SN)**



General note: the illustrations above are intended to provide a brief overview of the zone and are descriptive in nature.

**1. Intent**

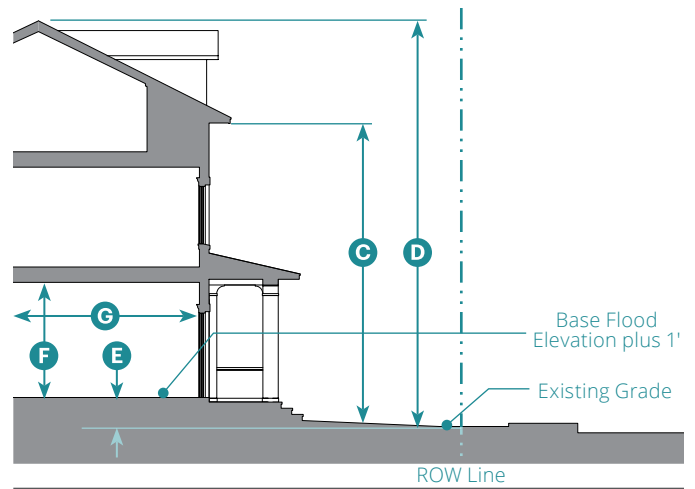
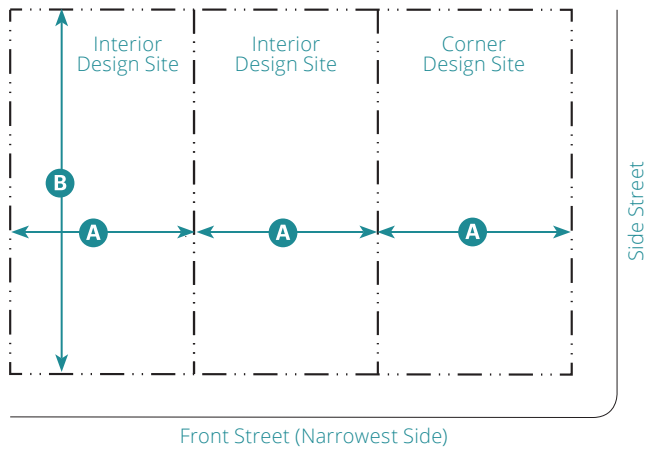
A walkable neighborhood environment of small-to-medium footprint, low-to-moderate-intensity housing choices, supporting and within short walking distance of neighborhood-serving retail and services.

The following are generally appropriate form elements in the zone.

House-Scale Buildings	Up to 2.5 Stories without Bonus; Up to 3 Stories with Bonus
Primarily Detached Buildings	
Small-to-Medium Building Footprint	House, Duplex Side-by-Side, Cottage Court, Fourplex, Neighborhood
Small-to-Medium Front Setbacks	Townhouse, and Pocket Neighborhood
Small-to-Medium Side Setbacks	Porch Projecting, Porch Engaged, and Dooryard Frontage Types

**2. Sub-Zone(s)**

None



**Key**

--- ROW/ Design Site Line

**Key**

--- ROW Line

3. Building Types and Design Site Size			
Allowed Building Types	Design Site <sup>1</sup>		Standards
	Width <b>A</b>	Depth <b>B</b>	
<b>House-Scale</b>			
Carriage House <sup>2</sup>	N/A	N/A	22.06.040
House	50' min.	100' min.	22.06.050
Duplex Side-by-Side	50' min.	110' min.	22.06.060
Cottage Court	125' min.	130' min.	22.06.080
Fourplex	50' min.	110' min.	22.06.090
Neighborhood Townhouse <sup>3</sup>	24' min. <sup>4</sup>	100' min.	22.06.100
Pocket Neighborhood	170' min.;	260' min.;	22.06.120
	300' max.	500' max.	

<b>Block-Scale</b>			
None			

Each design site shall have only one primary building type.

<sup>1</sup> Design sites of at least 3 acres or over 700' long or deep are required to include civic space and new street(s) per Chapter 9 (Specific to Large Sites).

<sup>2</sup> The Carriage House is not a primary building type.

<sup>3</sup> Max. 4 side-by-side

<sup>4</sup> Represents one townhouse

4. Building Form		
Height	Without Bonus	With Bonus
<b>Primary Building<sup>5</sup></b>		
Stories	2.5 max.	3 max.
To Highest Eave/Parapet	22' max.	32' max. <b>C</b>
Overall	29' max.	36' max. <b>D</b>
Ground Floor Finish Level (Base Flood Elevation plus 1') <b>E</b>		
Residential	6" min. <sup>6</sup>	
Non-Residential	Not Allowed	
Ground Floor Ceiling <b>F</b>		
Residential	9' min.	
Non-Residential	Not Allowed	
<b>Accessory Structure(s)</b>		
Area	1 max.	
	120 sf max.	

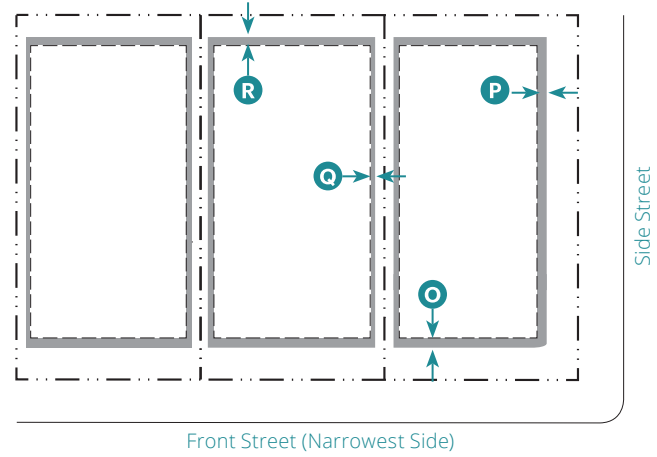
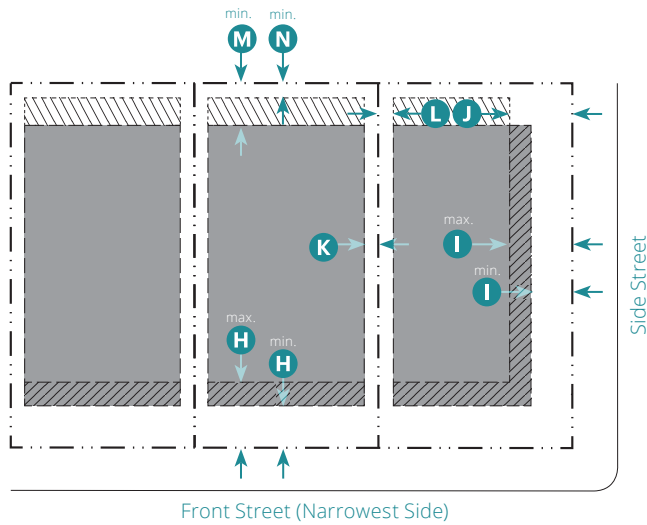
<b>Footprint</b>	
Max. Design Site Coverage	See standards in Chapter 6 (Specific to Building Types)
Depth, Ground-Floor Space	30' min. <sup>7</sup> <b>G</b>

<sup>5</sup> See Chapter 6 (Specific to Building Types) for refinements to massing and height standards.

<sup>6</sup> Common entries may be set at grade in compliance with local and federal accessibility standards.

<sup>7</sup> For habitable/occupiable space only, except in the Cottage Court Building Type





<b>Key</b>	Buildable Area
- · - · - ROW/ Design Site Line	Acc. Structures Only
- - - Building Setback Line	Facade Zone

<b>Key</b>	Encroachment Area
- · - · - ROW/ Design Site Line	
- - - Setback Line	

**5. Building Placement**

**Setback (Distance from ROW/ Design Site Line)**

Front (Facade Zone)		<b>H</b>
Interior Design Site	15' min.; 25' max.	
Corner Design Site	15' min.; 25' max.	
Side Street (Facade Zone)		
Primary Building	10' min.; 20' max.	<b>I</b>
Accessory Structure(s)	20' min.	<b>J</b>
Side		
Primary Building	7' min.	<b>K</b>
Accessory Structure(s)	5' min.	<b>L</b>
Adjacent to Lagoon	10' min.	
Rear		
Primary Building <sup>8</sup>	20' min.	<b>M</b>
Accessory Structure(s) <sup>9</sup>	5' min.	<b>N</b>

**Building Facade**

Facade Zone Defined By Building	Front St.	Side St.
Total length of facade required within or abutting the facade zone, exclusive of setbacks	60% min.	50% min.

**Facade Design**

All building facades shall be designed in compliance with Chapter 8 (Specific to Architectural Design).

<sup>8</sup>Rear setback shall be measured from the summer high water line.

<sup>9</sup>Where abuts lagoon, rear setback shall be 10' min. as measured from the summer high water line.

**6. Encroachments**

**Encroachments into Minimum Setbacks**

Encroachment Type	Front <b>O</b>	Side St. <b>P</b>	Side <b>Q</b>	Rear <b>R</b>
Roof Rake/Eave	4' max.	4' max.	3' max.	4' max.

Ramps providing ADA or FHA visitability are allowed within setbacks but shall not encroach within public ROWs.

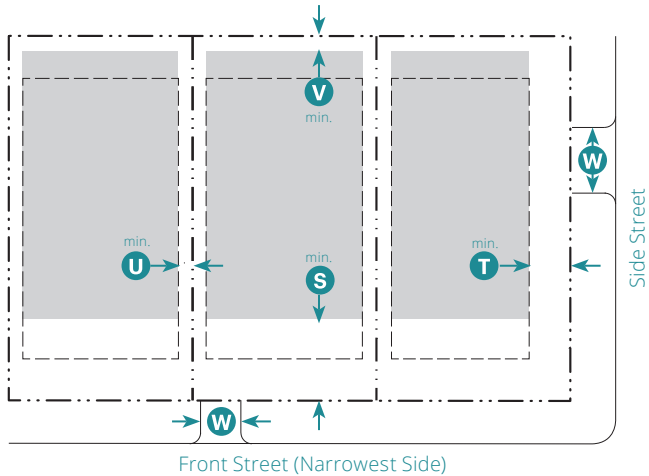
Fences, hedges, and other screen devices are allowed within setbacks as identified in Section 19.48.190 (Residential Zones—Certain Facilities and Structures Permitted in Yards).

**Encroachments into Public Right of Ways (ROW)**

Encroachments at grade not allowed within a street ROW, alley ROW, or across a design site line.

Upper story encroachments on front and side street require 8' min. of vertical clearance.

<b>Key</b>	X = Not Allowed	N/A = Not Applicable
------------	-----------------	----------------------



**Key**

- - - ROW/ Design Site Line
- - - Building Setback Line
- Parking Area

**7. Parking**

Use Type	Vehicular Spaces <sup>10</sup>	Bicycle Spaces <sup>11</sup>
<b>Residential Uses</b>		
Studio or 1 Bedroom	1 min. per unit	1 min. per unit
2 or More Bedrooms	1.5 min. per unit	2 min. per unit
<b>Non-Residential Uses per Building<sup>12</sup></b>		
≤ 1,000 sf	0 min.	
≥ 1,000 sf	1 min. per 1,000 sf above first 1,000 sf	

**Setback (Distance from ROW/ Design Site Line)**

Front	50' min.	<b>S</b>
Side Street	20' min.	<b>T</b>
Side	5' min.	<b>U</b>
Rear	5' min.	<b>V</b>

Driveway <sup>13</sup>	One-Way	Two-Way
Curb Cut/Width	8' max.	Not Allowed <b>W</b>

<sup>10</sup> See Subsection 22.05.040.5 for additional standards.  
<sup>11</sup> See Subsection 22.05.040.3 for additional standards.  
<sup>12</sup> See Chapter 4 (Specific to Uses) for allowed uses.  
<sup>13</sup> See Subsection 22.05.040.8.C for additional standards.

Curb cut width along alley may exceed 8'.  
 Driveways may be shared between adjacent design sites but shall not exceed maximum allowed width.  
 Front access not allowed on corner design sites.  
 Bicycles may be parked anywhere on design site, in compliance with pedestrian and vehicular access standards.

**8. Frontages**

Allowed Private Frontage Type	Standards
Porch Projecting	22.07.040
Porch Engaged	22.07.050
Dooryard	22.07.060
Allowed Public Frontage Type	Standards
Street	22.05.050.C.1

**22.03.040 T4 Suburban Neighborhood.Small (T4SN.S)**



General note: the illustrations above are intended to provide a brief overview of the zone and are descriptive in nature.

**1. Intent**

A walkable neighborhood environment of small-to-medium footprint, moderate-intensity housing choices, supporting and within short walking distance of neighborhood-serving retail and services.

The following are generally appropriate form elements in the zone.

House-Scale Buildings

Primarily Detached Buildings

Small-to-Medium Building Footprint

Small-to-Medium Front Setbacks

Small-to-Medium Side Setbacks

Up to 2.5 Stories without Bonus; up to 3 Stories with Bonus

House, Duplex Stacked, Cottage Court,

Fourplex, Neighborhood Townhouse,

Neighborhood Courtyard, Pocket

Neighborhood, and Multiplex

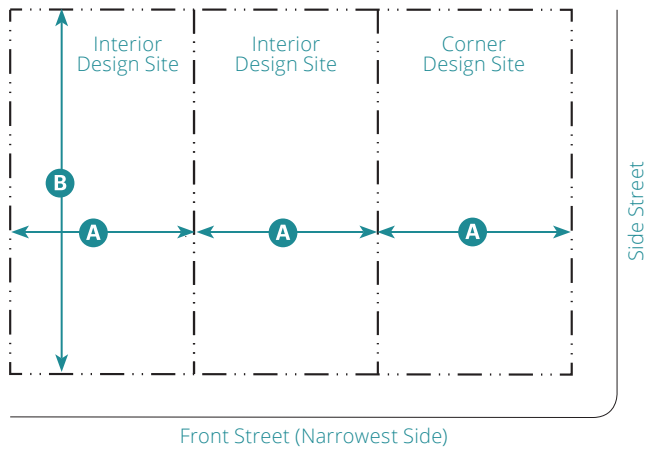
Porch Projecting, Porch Engaged,

Dooryard, and Stoop Frontage Types;

Shopfront in Open Sub-Zone

**2. Sub-Zone(s)**

T4SN.S-Open. The open sub-zone allows more uses and additional frontages within the same form and character of the base zone.



**Key**

--- ROW/ Design Site Line

3. Building Types and Design Site Size			
Allowed Building Types	Design Site <sup>1</sup>		Standards
	Width <b>A</b>	Depth <b>B</b>	
<b>House-Scale</b>			
Carriage House <sup>2</sup>	N/A	N/A	22.06.040
House	50' min.	100' min.	22.06.050
Duplex Stacked	50' min.	100' min.	22.06.070
Cottage Court	90' min.	120' min.	22.06.080
Fourplex	50' min.	110' min.	22.06.090
Neighborhood Townhouse	18' min. <sup>3</sup>	100' min.	22.06.100
Neighborhood Courtyard	70' min. <sup>4</sup>	150' min.	22.06.110
Pocket Neighborhood	170' min.;	260' min.;	22.06.120
	300' max.	500' max.	
Multiplex	100' min.	125' min.	22.06.130

**Block-Scale**

None

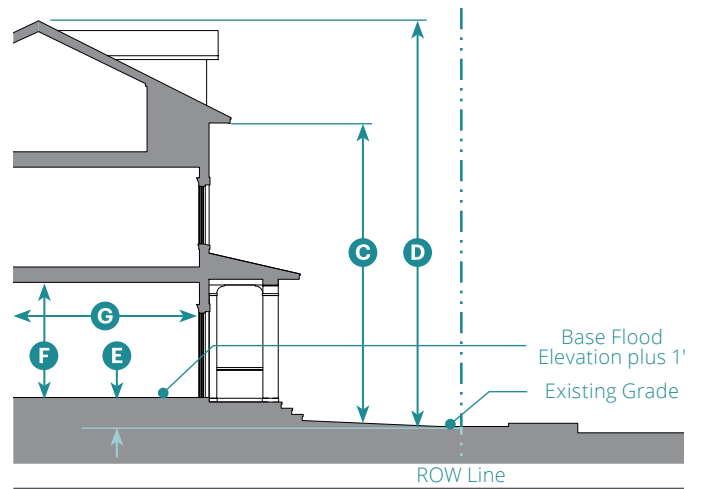
Each design site shall have only one primary building type.

<sup>1</sup>Design sites of at least 3 acres or over 700' long or deep are required to include civic space and new street(s) per Chapter 9 (Specific to Large Sites).

<sup>2</sup>The Carriage House is not a primary building type.

<sup>3</sup>Represents up to 2 stacked units.

<sup>4</sup>For an L-shaped building; 100' min. for a U-shaped building



**Key**

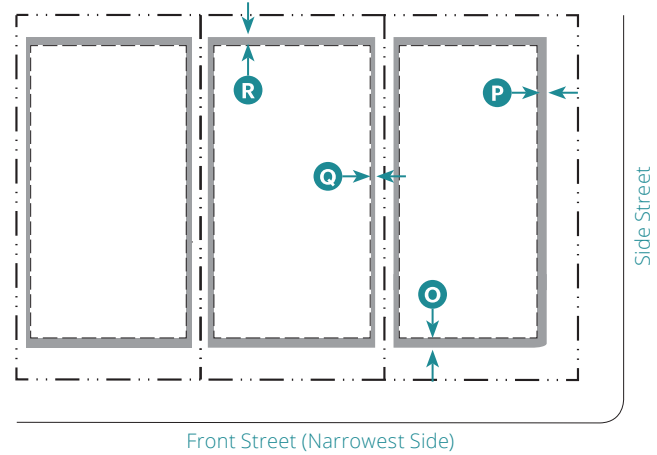
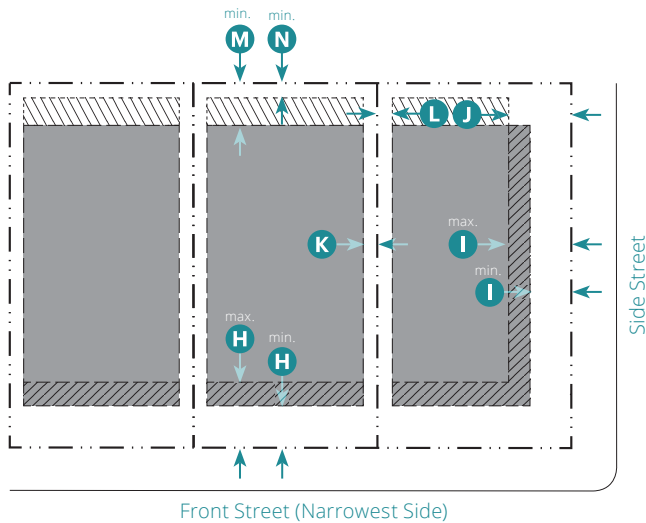
--- ROW Line

4. Building Form		
Height	Without Bonus	With Bonus
<b>Primary Building<sup>5</sup></b>		
Stories	2.5 max.	3 max.
To Highest Eave/Parapet	23' max.	33' max. <b>C</b>
Overall	29' max.	36' max. <b>D</b>
Ground Floor Finish Level (Base Flood Elevation plus 1') <b>E</b>		
Residential	6" min. <sup>6</sup>	
Non-Residential	6" max.	
Ground Floor Ceiling <b>F</b>		
Residential	9' min.	
Non-Residential	12' min.	
<b>Accessory Structure(s)</b>		
Area	1 max.	
	120 sf max.	
<b>Footprint</b>		
Max. Design Site Coverage	See standards in Chapter 6 (Specific to Building Types)	
Depth, Ground-Floor Space	20' min. <sup>7</sup> <b>G</b>	

<sup>5</sup>See Chapter 6 (Specific to Building Types) for refinements to massing and height standards.

<sup>6</sup>Common entries may be set at grade in compliance with local and federal accessibility standards.

<sup>7</sup>For habitable/occupiable space only, except in the Cottage Court Building Type



<b>Key</b>	Buildable Area
- · · · ROW/ Design Site Line	Acc. Structures Only
- - - Building Setback Line	Facade Zone

<b>Key</b>	Encroachment Area
- · · · ROW/ Design Site Line	
- - - Setback Line	

**5. Building Placement**

**Setback (Distance from ROW/ Design Site Line)**

Front (Facade Zone)		<b>H</b>
Interior Design Site	10' min.; 20' max.	
Corner Design Site	10' min.; 20' max.	
Side Street (Facade Zone)		
Primary Building	10' min.; 20' max.	<b>I</b>
Accessory Structure(s)	20' min.	<b>J</b>
Side		
Primary Building	7' min.	<b>K</b>
Accessory Structure(s)	5' min.	<b>L</b>
Adjacent to Lagoon	10' min.	
Rear		
Primary Building <sup>8</sup>	15' min.	<b>M</b>
Accessory Structure(s) <sup>9</sup>	5' min.	<b>N</b>

**Building Facade**

Facade Zone Defined By Building	Front St.	Side St.
Total length of facade required within or abutting the facade zone, exclusive of setbacks	65% min.	55% min.

**Facade Design**

All building facades shall be designed in compliance with Chapter 8 (Specific to Architectural Design).

<sup>8</sup>Rear setback shall be measured from the summer high water line.

<sup>9</sup>Where abuts lagoon, rear setback shall be 10' min. as measured from the summer high water line.

**6. Encroachments**

**Encroachments into Minimum Setbacks**

Encroachment Type	Front <b>O</b>	Side St. <b>P</b>	Side <b>Q</b>	Rear <b>R</b>
Roof Rake/Eave	3' max.	3' max.	3' max.	5' max.

Ramps providing ADA or FHA visitability are allowed within setbacks but shall not encroach within public ROWs.

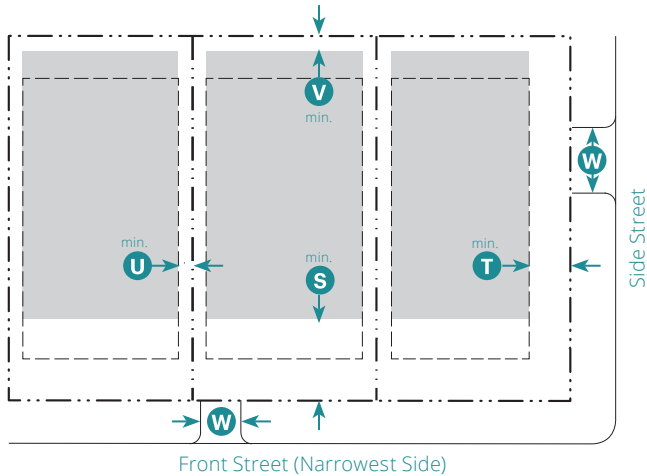
Fences, hedges, and other screen devices are allowed within setbacks as identified in Section 19.48.190 (Residential Zones—Certain Facilities and Structures Permitted in Yards).

**Encroachments into Public Right of Ways (ROW)**

Encroachments at grade not allowed within a street ROW, alley ROW, or across a design site line.

Upper story encroachments on front and side street require 8' min. of vertical clearance.

<b>Key</b>	X = Not Allowed	N/A = Not Applicable
------------	-----------------	----------------------



**Key**

- - - ROW/ Design Site Line
- - - Building Setback Line
- Parking Area

**7. Parking**

Use Type	Vehicular Spaces <sup>10</sup>	Bicycle Spaces <sup>11</sup>
<b>Residential Uses</b>		
Studio or 1 Bedroom	1 min. per unit	1 min. per unit
2 or More Bedrooms	1.5 min. per unit	2 min. per unit

<b>Non-Residential Uses per Building<sup>12</sup></b>		
≤ 1,000 sf	0 min.	
≥ 1,000 sf	1 min. per 1,000 sf above first 1,000 sf	

<b>Setback (Distance from ROW/ Design Site Line)</b>		
Front	40' min.	<b>S</b>
Side Street	20' min.	<b>T</b>
Side	5' min.	<b>U</b>
Rear	5' min.	<b>V</b>

Driveway <sup>13</sup>	One-Way	Two-Way
Curb Cut/Width	8' max.	Not Allowed <b>W</b>

<sup>10</sup> See Subsection 22.05.040.5 for additional standards.  
<sup>11</sup> See Subsection 22.05.040.3 for additional standards.  
<sup>12</sup> See Chapter 4 (Specific to Uses) for allowed uses.  
<sup>13</sup> See Subsection 22.05.040.8.C for additional standards.  
 Curb cut width along alley may exceed 8'.  
 Driveways may be shared between adjacent design sites but shall not exceed maximum allowed width.  
 Front access not allowed on corner design sites.  
 Bicycles may be parked anywhere on design site, in compliance with pedestrian and vehicular access standards.

**8. Frontages**

Allowed Private Frontage Type	Standards
Porch Projecting	22.07.040
Porch Engaged	22.07.050
Dooryard	22.07.060
Stoop	22.07.070
Shopfront <sup>14</sup>	22.07.100
Allowed Public Frontage Type	Standards
Street	22.05.050.C.1

<sup>14</sup> Open sub-zone only



**22.03.050 T4 Suburban Main Street.Small (T4SMS.S)**



*General note: the illustrations above are intended to provide a brief overview of the zone and are descriptive in nature.*

**1. Intent**

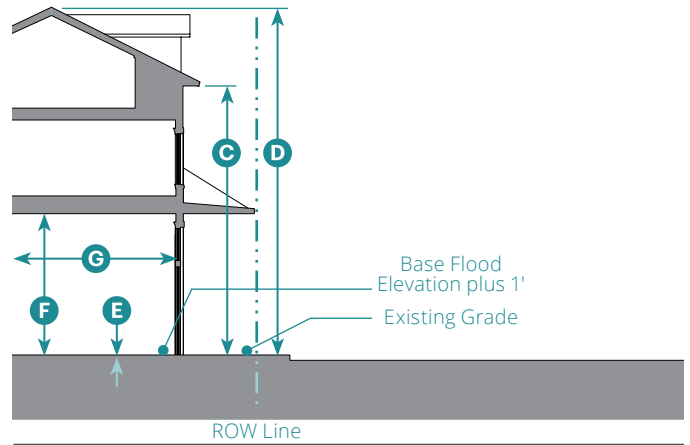
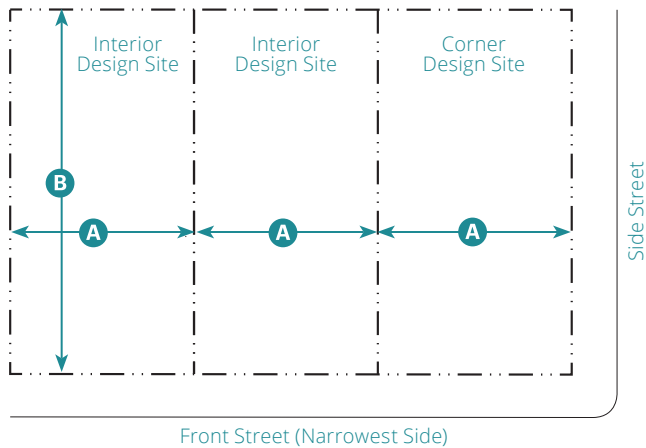
A walkable, vibrant district of small-to-medium footprint, moderate intensity, mixed-use buildings and housing choices, supporting neighborhood-serving ground floor retail, food and services.

The following are generally appropriate form elements in the zone.

Primarily House-Scale Buildings	House, Neighborhood Townhouse,
Primarily Attached Buildings	Neighborhood Courtyard, Multiplex,
Small-to-Medium Building Footprint	and Main Street Building
None-to-Small Front Setbacks	Porch Projecting, Porch Engaged,
None-to-Small Side Setbacks	Forecourt, Shopfront, Terrace, and
Up to 2.5 Stories without Bonus; up to 3 Stories with Bonus	Gallery Frontage Types; Dooryard, Stoop, and Maker Shopfront Frontage Types in Open Sub-Zone or on Side Street

**2. Sub-Zone(s)**

T4SMS.S-Open. The open sub-zone allows more uses and additional frontages, within the same form and character of the base zone.



**Key**

--- ROW/ Design Site Line

**Key**

--- ROW Line

**3. Building Types and Design Site Size**

Allowed Building Types	Design Site <sup>1</sup>		Standards
	Width <b>A</b>	Depth <b>B</b>	
<b>House-Scale</b>			
Carriage House <sup>2</sup>	N/A	N/A	22.06.040
House	50' min.	100' min.	22.06.050
Neighborhood Townhouse	18' min. <sup>3</sup>	100' min.	22.06.100
Neighborhood Courtyard	70' min. <sup>4</sup>	150' min.	22.06.110
Multiplex	60' min.	110' min.	22.06.130
<b>Block-Scale</b>			
Main Street Building	25' min.	100' min.	22.06.140

Each design site shall have only one primary building type.

<sup>1</sup> Design sites of at least 3 acres or over 700' long or deep are required to include civic space and new street(s) per Chapter 9 (Specific to Large Sites).

<sup>2</sup> The Carriage House is not a primary building type.

<sup>3</sup> Represents up to 2 stacked units.

<sup>4</sup> For an L-shaped building; 100' min. for a U-shaped building

**4. Building Form**

Height	Without Bonus	With Bonus	
<b>Primary Building<sup>5</sup></b>			
Stories	2.5 max.	3 max.	
To Highest Eave/Parapet	26' max.	35' max.	<b>C</b>
Overall	29' max.	36' max.	<b>D</b>
Ground Floor Finish Level (Base Flood Elevation plus 1')			
Residential	6" min. <sup>6,7</sup>		<b>E</b>
Non-Residential	6" max.		
Ground Floor Ceiling	14' min.		<b>F</b>
<b>Accessory Structure(s)</b>			
Area	120 sf max.		

**Footprint**

Max. Design Site Coverage	See standards in Chapter 6 (Specific to Building Types)
Depth, Ground-Floor Space	30' min. <sup>8</sup> <b>G</b>

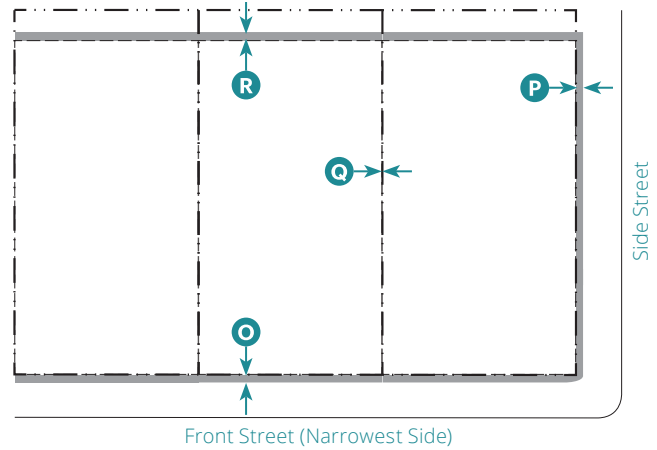
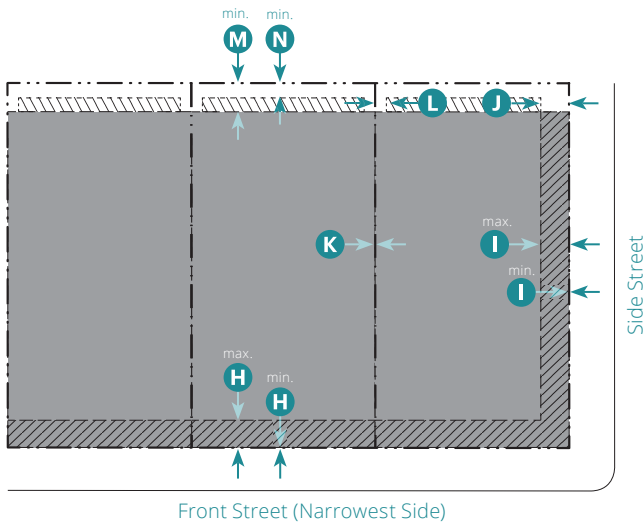
<sup>5</sup> See Chapter 6 (Specific to Building Types) for refinements to massing and height standards.

<sup>6</sup> Common entries may be set at grade in compliance with local and federal accessibility standards.

<sup>7</sup> Only on side street and at least 60' from front of design site

<sup>8</sup> For habitable/occupiable space only





<b>Key</b>	Buildable Area
- · · · ROW/ Design Site Line	Acc. Structures Only
- - - Building Setback Line	Facade Zone

**5. Building Placement**

**Setback (Distance from ROW/ Design Site Line)**

Front (Facade Zone)		<b>H</b>
Interior Design Site	0' min.; 10' max.	
Corner Design Site	0' min.; 10' max.	
Side Street (Facade Zone)		
Primary Building	0' min.; 10' max.	<b>I</b>
Accessory Structure(s)	10' min.	<b>J</b>
Side		
Primary Building	0' min.	<b>K</b>
Adjacent to Residential Zone	10' min.	
Accessory Structure(s)	3' min.	<b>L</b>
Rear		
Primary Building <sup>9</sup>	15' min.	<b>M</b>
Adjacent to Residential Zone	20' min.	
Accessory Structure(s) <sup>10</sup>	5' min.	<b>N</b>

**Building Facade**

<b>Facade Zone Defined By Building</b>	<b>Front St.</b>	<b>Side St.</b>
Total length of facade required within or abutting the facade zone, exclusive of setbacks	65% min.	55% min.

**Facade Design**

All building facades shall be designed in compliance with Chapter 8 (Specific to Architectural Design).

<sup>9</sup>Rear setback shall be measured from the summer high water line.

<sup>10</sup>Where abuts lagoon, rear setback shall be 10' min. as measured from the summer high water line.

<b>Key</b>	Encroachment Area
- · · · ROW/ Design Site Line	Encroachment Area
- - - Setback Line	

**6. Encroachments**

**Encroachments into Minimum Setbacks**

<b>Encroachment Type</b>	<b>Front</b>	<b>Side St.</b>	<b>Side</b>	<b>Rear</b>
	<b>O</b>	<b>P</b>	<b>Q</b>	<b>R</b>
Roof Rake/Eave	3' max.	3' max.	X	5' max.

Ramps providing ADA or FHA visitability are allowed within setbacks but shall not encroach within public ROWs.

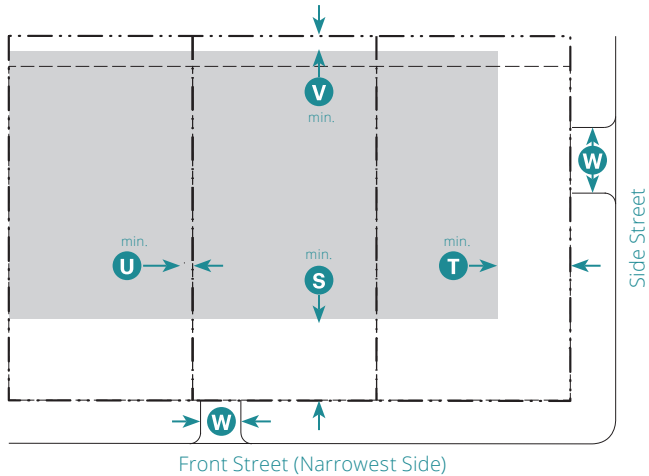
Fences, hedges, and other screen devices are allowed within setbacks as identified in Section 19.48.190 (Residential Zones—Certain Facilities and Structures Permitted in Yards).

**Encroachments into Public Right of Ways (ROW)**

Encroachments at grade not allowed within a street ROW, alley ROW, or across a design site line.

Upper story encroachments on front and side street require 8' min. of vertical clearance.

<b>Key</b>	X = Not Allowed	N/A = Not Applicable
------------	-----------------	----------------------



**Key**

- - - - ROW/ Design Site Line
- - - - Building Setback Line
- Parking Area

7. Parking		
Use Type	Vehicular Spaces <sup>11</sup>	Bicycle Spaces <sup>12</sup>
<b>Residential Uses</b>		
Studio or 1 Bedroom	1 min. per unit	1 min. per unit
2 or More Bedrooms	1 min. per unit	2 min. per unit
<b>Non-Residential Uses per Building<sup>13</sup></b>		
≤ 3,000 sf	0 min.	
≥ 3,000 sf	1 min. per 1,000 sf above first 3,000 sf	
<b>Setback (Distance from ROW/ Design Site Line)</b>		
Front	40' min.	<b>S</b>
Side Street	40' min.	<b>T</b>
Side	0' min.	<b>U</b>
Rear	5' min.	<b>V</b>
<b>Driveway<sup>14</sup></b>		
	<b>One-Way</b>	<b>Two-Way</b>
Curb Cut/Width	8' max.	12' max.

<sup>11</sup> See Subsection 22.05.040.5 for additional standards.

<sup>12</sup> See Subsection 22.05.040.3 for additional standards.

<sup>13</sup> See Chapter 4 (Specific to Uses) for allowed uses.

<sup>14</sup> See Subsection 22.05.040.8.C for additional standards.

Curb cut width along alley may exceed 12'.

Driveways may be shared between adjacent design sites but shall not exceed maximum allowed width.

Front access not allowed on corner design sites.

Bicycles may be parked anywhere on design site, in compliance with pedestrian and vehicular access standards.

8. Frontages	
Allowed Private Frontage Type	Standards
Porch Projecting	22.07.040
Porch Engaged	22.07.050
Dooryard <sup>15</sup>	22.07.060
Stoop <sup>16</sup>	22.07.070
Forecourt	22.07.080
Maker Shopfront <sup>16</sup>	22.07.090
Shopfront	22.07.100
Terrace	22.07.110
Gallery	22.07.120
Allowed Public Frontage Type	Standards
Avenue/Boulevard	22.05.050.C.2
Main Street	22.05.050.C.3

<sup>15</sup> Only on side street

<sup>16</sup> Open sub-zone only

# Chapter 4: Specific to Uses

---

**Sections:**

- 22.04.010 Purpose
- 22.04.020 Use Standards
- 22.04.030 Use Table

---

**22.04.010 Purpose**

This Chapter provides the standards for uses in each zone to implement the intent described in Chapter 3 (Zones).

---

**22.04.020 Use Standards**

Table 22.04.030.A (Uses) identifies the following for each zone: the allowed uses ("P") and the uses that are not allowed ("X"). In addition, as required, specific use-standards are identified. Uses not listed are not allowed.

## 22.04.030 Use Table

**Table 22.04.030.A: Uses**

	Zones				
	T3	T4			
	SN	SN.S	SN.S-O	SMS.S	SMS.S-O
<b>Commercial Uses</b>					
Alcohol Sales	X	X	P <sup>1</sup>	P	P
Eating and Drinking Establishment	X	X	P <sup>1</sup>	P	P
Office-General	X	X	P <sup>1</sup>	P <sup>2</sup>	P
Office-Medical/Dental	X	X	P <sup>1</sup>	P <sup>2</sup>	P
Indoor Recreation	X	X	P <sup>1</sup>	P	P
Lodging	X	X	P	P	P
Parking Facilities-Municipal	X	X	X	P	P
Retail-General	X	X	P <sup>1</sup>	P	P
Services-General	X	X	P <sup>1</sup>	P	P
Veterinary Clinics	X	X	X	P	P
<b>Institutional and Civic Uses</b>					
Community Assembly	P <sup>1</sup>	X	P <sup>1</sup>	P	P
Daycare					
Adult	P	X	P	P	P
7-12 Children	P	X	P	P	P
1-6 Children	P	X	P	P	P
Park and Outdoor Recreation	P	P	P	P	P
School-Public and Private	P <sup>1</sup>	P <sup>1</sup>	P	P	P
Studio: Art, Music, Dance	P <sup>3</sup>	P <sup>1</sup>	P	P	P

<sup>1</sup> Max. 1,500 sf per building

<sup>2</sup> Not allowed on the ground floor within 30' of the sidewalk

<sup>3</sup> Only allowed in an accessory structure

**Key**            P = Allowed        X = Not Allowed

**Table 22.04.030.A: Uses (Continued)**

	Zones				
	T3	T4			
	SN	SN.S	SN.S-O	SMS.S	SMS.S-O
<b>Residential Uses</b>					
Dwelling	P	P	P	p <sup>2</sup>	P
Group Living-Assisted	P <sup>1</sup>	P <sup>1</sup>	P	p <sup>2</sup>	P
Group Living-General	P <sup>1</sup>	P <sup>1</sup>	P	p <sup>2</sup>	P
Group Living-Independent	P <sup>1</sup>	P <sup>1</sup>	P	p <sup>2</sup>	P
Live/Work	X	X	P	P	P
Missing Middle Housing	P	P	P	P	P
Single-Unit Housing	P	X	X	X	X

<sup>1</sup> Max. 1,500 sf per building

<sup>2</sup> Not allowed on the ground floor within 30' of the sidewalk

<sup>3</sup> Only allowed in an accessory structure

**Key**                    P = Allowed                    X = Not Allowed

*This page intentionally left blank*

# Chapter 5: General to Design Sites

---

## Sections:

22.05.010	Purpose
22.05.020	Screening
22.05.030	Landscaping and Lighting
22.05.040	Parking and Loading
22.05.050	Public Frontage Standards
22.05.060	Privacy Standards

---

## 22.05.010 Purpose

This Chapter provides standards to ensure that new development accomplishes the following:

1. Makes a positive contribution to the development pattern of the area;
2. New or altered structures are compatible with the design and use of existing structures on neighboring properties;
3. Respects the existing conditions of neighboring properties; and
4. Does not adversely affect neighboring properties, with "adversely affect" meaning to impact in a substantial, negative manner the habitability of these properties.

---

## 22.05.020 Screening

1. **Intent.** This Section provides standards for screening, fences, and walls for the protection of property, the enhancement of privacy, the attenuation of noise, and the improvement of the visual environment.
2. **Design Standards for Screening.** Except for wall- and ground-mounted equipment that is not visible from the public right-of-way or abutting design sites, all equipment shall comply with the following:
  - A. **Screening Height Maximums.** Screening shall not exceed the maximums identified in Table A (Maximum Screening Height).
  - B. **Screening Height Measurement.** Screening height shall be measured as the vertical distance between the finished grade at the base of the screen and the top edge of the screen material.

Zone	Item	Maximum Height Allowed			
		Front	Side St.	Side	Rear
T3SN	Fences	3' max.	3' max.	8' max.	8' max.
	Free Standing Walls	3' max.	3' max.	4' max.	4' max.
	Landscaping <sup>1</sup>	4' max.	4' max.	8' max.	6' max.
T4SN.S	Fences	3' max.	3' max.	8' max.	8' max.
	Free Standing Walls	3' max.	3' max.	8' max.	8' max.
	Landscaping <sup>1</sup>	4' max.	4' max.	No max.	No max.
T4SMS.S	Fences	X	X	10' max.	10' max.
	Free Standing Walls	X	X	10' max.	10' max.
	Landscaping <sup>1</sup>	3' max.	3' max.	No max.	No max.

<sup>1</sup> Excludes trees if the rear yard abuts Lagoon; fencing and walls shall comply with Administrative Policy Manual 15.4.4

**Key** X = Not Allowed

### 3. Courtyard Screening

- A. Fences, walls and other screening installed to create a courtyard without a roof shall not exceed five feet in height and shall be set back a minimum of 10 feet from the front property line or back of sidewalk, whichever is the least.
- B. Landscaping installed in compliance with Section 22.05.030 (Landscaping and Lighting).

### 4. Screening on Retaining Walls.

The total height of screens and the retaining walls they are mounted on or attached to shall not exceed six feet.

### 5. Mechanical Equipment Screening

- A. The following mechanical equipment is exempt from screening:
  - (1) Free-standing or roof-mounted solar equipment; and
  - (2) Vents less than two feet in height.
- B. For new installation or relocation of existing mechanical equipment, the equipment shall be screened.
  - (1) **Roof-Mounted Equipment.** Building parapets or other architectural elements in the building's architectural style shall screen roof-mounted equipment.
    - (a) New buildings shall be designed to provide a parapet or other architectural element that is as tall or taller than the highest point on any new mechanical equipment to be located on the roof of the building; and
    - (b) For existing buildings with no parapet less than two feet in height, mechanical equipment shall be surrounded on all sides by an opaque screen wall as tall as the highest point of the equipment. The wall shall be architecturally consistent with the building and match the existing building with paint, finish, and trim cap detail.



(2) **Wall- and Ground-Mounted Equipment**

- (a) Equipment is not allowed between front or side street facades and the street.
- (b) All screen devices shall be as high as the highest point of the equipment being screened.
- (c) Equipment and screening shall be in compliance with the setbacks of the zone.
- (d) Screening shall be architecturally compatible and include matching paint, finish, and trim cap of the building.

- 6. **Temporary Fencing.** Temporary fencing may be used to provide security for approved special events, construction sites, or vacant structures and land, which cannot otherwise be secured. All temporary fencing shall be in compliance with Section 20.04.150 (Fences and Screening).
- 7. **Barbed Wire and Razor Wire.** Barbed wire and razor wire screening are not allowed.
- 8. **Safety.** Fences, walls, and other screening and landscaping, whether provided in compliance with the provisions of this Subsection or provided in addition to those provisions, are subject to review by the Traffic Engineer in the following areas to ensure that visibility is maintained:
  - A. Within 10 feet of the point of intersection of:
    - (1) A vehicular access way or driveway and a street; and/or
    - (2) A vehicular access way or driveway and a sidewalk.
  - B. Within 20 feet of the point of intersection of two or more vehicular access ways, including driveways, alleys, or streets.
  - C. As used in this Subsection, "point of intersection" is measured from the face of curb or if none, from the edge of pavement.

---

## 22.05.030 Landscaping and Lighting

1. **Intent.** This Section prescribes landscaping and lighting standards for protection and enhancement of the environmental and visual quality of the community, enhancement of privacy, and the control of dust.
2. **Required Landscaping.** The landscaping required by this Section shall be installed as part of the development or improvement(s) requiring the landscaping. Standards for landscaping in parking areas shall be in combination with Section 22.05.040 (Parking and Loading).
  - A. Landscaping materials shall be integrated into the required setbacks, stream and wetland buffers, and design of the selected private frontage type(s).
  - B. Landscape materials shall be applied to the planting areas identified for public frontage type(s).
3. **Required Lighting**
  - A. Site improvements, including lighting, as required to be consistent with the selected Architectural Style for the primary building.
  - B. Lighting shall be provided in compliance with the following:
    - (1) Exterior lighting shall be shielded and directed downward, with location of lights coordinated with the approved landscape plan.
    - (2) Exterior lamps shall be low wattage, incandescent, and except for outdoor Christmas lights, shall not be colored.
    - (3) Skylights shall not have white or light opaque colored exterior lenses.
    - (4) All exterior lighting shall be dark sky compliant, and designed, located and lamped in order to prevent overlighting, energy waste, glare, and light trespass.
    - (5) All parking lot lights shall be full cutoff luminaires, as certified by the manufacturer, with the light source directed downward and away from adjacent residences.
    - (6) Bollard lighting may be used to light walkways and other landscape features, but shall cast its light downward.
    - (7) Internally illuminated fascia, wall, roof, awning or other building parts are prohibited.
    - (8) All nonessential exterior lighting associated with non-residential uses shall be turned off within ½ hour after the close of business or when the non-residential use is not in use.
4. **Design Standards**
  - A. **Allowed Landscaping Materials**
    - (1) Landscaping materials shall comply with the following:
      - (a) Shrubs, of at least one-gallon size;
      - (b) Ground cover instead of grass/turf; and/or
      - (c) Decorative nonliving landscaping materials including, but not limited to, sand, stone, gravel, wood or water may be used to satisfy a maximum of 25 percent of the required landscaping area.
    - (2) Street trees, of at least 15-gallon size, double-staked, planted between the curb and the back of the sidewalk.

**B. Species Selection**

- (1) Native and drought tolerant species are required to meet the minimum standards, in conformance with MMWD Water Conservation Ordinance 414.
- (2) Landscape selection shall include native vegetation, applicable to Marin County, in compliance with Water Use Classification of Landscape Species (WUCOL IV).
- (3) Landscaping shall be in compliance with Tiburon Fire Protection District.

**C. Retaining Walls**

- (1) Retaining walls within the front and/or side street façade zone(s) or visible from the public sidewalk adjoining the design site shall:
  - (a) Not exceed four feet in height as measured to the adjacent finished grade or sidewalk whichever is nearest;
  - (b) Include a landscape planter in front of the wall. The planter shall be at least 18 inches deep measured perpendicular to the wall; and/or
  - (c) Be finished with allowable wall material(s) of the selected architectural style for the primary building.
- (2) Retaining walls along the interior design site line that are beyond the front and/or side street façade zone(s) shall:
  - (a) Not exceed three feet as measured to the adjacent finished grade; if the lot abuts Lagoon, retaining walls shall comply with Administrative Policy Manual 15.4.4;
  - (b) Include a landscape planter in front of the wall. The planter shall be at least three feet deep measured perpendicular to the wall; and/or
  - (c) Be finished with allowable wall material(s) of the selected architectural style for the primary building.
- (3) Retaining walls along the rear design site line that are beyond the front and/or side street façade zone(s) shall:
  - (a) Not exceed eight feet as measured to the adjacent finished grade;
  - (b) If exposed, include a landscape planter in front of the wall. The planter shall be at least three feet deep measured perpendicular to the wall;
  - (c) Be finished with allowable wall material(s) of the selected architectural style for the primary building; and/or
  - (d) Not require landscaping or wall material finish(es) if within the building and not exposed.

- D. Maintenance.** Required landscaping shall be maintained in a clean and healthy condition. This includes pruning, weeding, removal of litter, fertilizing, replacement of plants when necessary, and the appropriate watering of all landscaping.

---

## 22.05.040 Parking and Loading

1. **Intent.** This Section prescribes standards for motor vehicle and bicycle parking areas, loading and access drives, and standards for reducing motor vehicle trips per capita to and from development. These standards are intended to ensure that new development accomplishes the following:
  - A. Consistency with the intended physical character of walkable environments;
  - B. Provision of bicycle parking to increase bicycle trips and reduce motor vehicle trips per capita; and
  - C. Appropriately limits, screens, and landscapes motor vehicle parking areas to protect and enhance the environmental and visual quality of the community, enhance privacy, attenuate noise, and control dust.
2. **On-site parking.** On-site parking is allowed in all zones subject to the standards in this Section.
3. **Bicycle Parking Standards.** Bicycle parking shall be provided in compliance with the standards of the zone.
4. **General Vehicular Parking Standards**
  - A. **Sharing of On-Site Parking.** Sharing of parking between different uses and developments is allowed.
  - B. **Sharing of Non-Residential Parking Required.** If on-site parking spaces for non-residential uses are provided, such spaces shall be made available for use by the general public during at least one of the following time periods:
    - (1) Monday through Friday, 8 AM to 5 PM; or
    - (2) Monday through Friday, 5 PM to 11 PM and all day on Saturday and Sunday.
  - C. **Larger Vehicle Parking**
    - (1) Trucks, tractors or tractor-trailers having a capacity of more than a 1.5-ton load, front- and rear-end loaders, or any kind of commercial, industrial, agricultural, or transportation vehicles/equipment used primarily for business purposes, shall not be parked or stored in any zone for purposes other than unloading, loading, or delivery services.
    - (2) Automobiles, small trucks, vans, and vehicle trailers allowed in conjunction with an approved home occupation (one per home occupation), and recreational vehicles are excluded from the provisions of this Subsection.
  - D. **Storage of Unregistered or Inoperable Motor Vehicles.** Automotive vehicles, trailers, or vehicles of any kind or type, requiring licenses that are without current license plates or are inoperable shall only be parked within completely enclosed buildings.
  - E. **Cargo or Freight Container.** Portable cargo or freight storage containers in any zone for purposes of loading or unloading may be parked or stored on-premise for a period not to exceed 10 days in any one calendar year.
5. **Number of Motor Vehicle Parking Spaces Required**
  - A. **Required Spaces.** The minimum number of parking spaces required is listed in Subsection 7 of the zone. For any use not addressed in Subsection 7, parking shall not exceed a ratio equivalent to the average peak parking occupancy rate for the most comparable use in the Institute of Transportation Engineers Parking Generation Manual.

**B. Required Number of Parking Spaces**

- (1) When calculating the required number of parking spaces, numbers shall be rounded down to the closest whole number.
- (2) Parking systems that stack individual vehicles are counted as three spaces for every horizontal space identified.
- (3) **Calculating Required Parking for a Mixed-Use Development.** For a building with residential and non-residential uses, shared parking shall be calculated as follows. The sum of the required parking for the two use types as stated in Subsection 7 of the zone shall be divided by the factor listed in Table A (Shared Parking Factor for Two Uses). The required number of parking spaces shall be rounded up to the closest whole number.

<b>Table 22.05.040.A: Shared Parking Factor for Two Uses</b>				
	<b>Residential</b>	<b>Lodging</b>	<b>Office</b>	<b>Retail</b>
Residential	1.0	1.1	1.4	1.2
Lodging	1.1	1.0	1.7	1.3
Office	1.4	1.7	1.0	1.2
Retail	1.2	1.3	1.2	1.0

- C. **Exception in the Event of Changes of Use or Alterations to Existing Buildings or Structures.** If an existing building or structure is altered or existing land uses are changed, the existing number of parking spaces on a property may be retained, even if the resulting building, structure or land use would ordinarily be subject to a lower maximum parking allowance.
6. **Electric Vehicle Charging.** Electric vehicle charging facilities shall be provided in compliance with CA Green Standards Building Code, Title 24, Part 11.

7. **Traffic-Reducing Parking Standards**

A. **Carshare Parking Spaces**

- (1) Carshare parking spaces shall be provided in the amounts specified in Table B (Required Carshare Parking Spaces).

<b>Table 22.05.040.B: Required Carshare Parking Spaces</b>	
<b>Residential Uses</b>	<b>Carshare Parking Spaces Required</b>
0-49 units	None
50-100 units	1
101 or more units	2 + 1 per additional 200 units
<b>Office/Research &amp; Development Uses</b>	<b>Carshare Parking Spaces Required</b>
≤ 10,000 sf	None
> 10,000 sf	1 per 10,000 sf

- (2) The required carshare space(s) shall be made available, at no cost, to a carshare service for purposes of providing carshare services to its members. At the election of the property owner, the carshare spaces may be provided:
  - (a) On the design site; or
  - (b) On another off-street site within 1,000 feet of the design site.
- (3) Required carshare space or spaces shall be designed in a manner that will make the spaces accessible to non-resident subscribers from outside the building as well as building residents.
- (4) If no carshare service can make use of the dedicated carshare parking spaces, the spaces may be occupied by non-carshare vehicles; provided, however, that upon 90 days of advance written notice to the property owner from a carshare service, the property owner shall terminate any non-carsharing leases for such spaces and shall make the spaces available to the carshare service for its use of such spaces.

- B. **Carpool Spaces.** If parking is provided at a development, parking spaces reserved for use by carpool/vanpool vehicles shall be designated in preferred locations (including, but are not limited to, closest to building entries). The locations of these spaces shall be approved by the City. The minimum number of carpool spaces required is listed in Table C (Required Carpool Parking Spaces).

<b>Table 22.05.040.C: Required Carpool Parking Spaces</b>	
<b>Office/Research &amp; Development Uses</b>	<b>Carpool Parking Spaces Required</b>
≤ 40 parking spaces	None
> 40 parking spaces	10% of the total number of spaces
<b>Other Uses</b>	<b>Carpool Parking Spaces Required</b>
All Other Uses	None

C. **Parking Costs Unbundled from the Cost of Other Goods and Services**

- (1) **Residential Uses.** All off-street parking spaces accessory to residential uses in structures of four dwellings or more shall be leased or sold separately from the rental or purchase fees for dwellings for the life of the dwellings, such that potential renters or buyers have the option of renting or buying a residential unit at a price lower than would be the case if there were a single price for both the residential unit and the parking space. Renters or buyers of on-site inclusionary affordable units shall have an equal opportunity to rent or buy a parking space on the same terms and conditions as offered to renters or buyers of other dwellings.
- (2) **Non-Residential Uses.** All off-street parking spaces accessory to non-residential uses shall be leased or sold separately from the rental or purchase fees for non-residential building space for the life of the building, such that potential renters or buyers have the option of renting or buying building space at a price lower than would be the case if there were a single price for both the building space and the parking space.
- (3) **Exception.** Off-street parking spaces accessory to retail uses are not required to be leased or sold separately from retail space and may be offered to shoppers and other visitors free of charge for stays of up to two hours.

8. **Parking Spaces, Design and Layout**

- A. **Parking Facilities.** All off-street parking is required to be located within a carport or garage and shall be designed in compliance with the selected Architectural style of the primary building.
- B. **Access.** On-site parking areas shall be accessed per the following:
  - (1) On-site parking shall be designed with an appropriate means of vehicular access to a street or to an alley to cause the least interference with traffic flow.
  - (2) Ingress to and egress from parking spaces shall be from an on-site aisle or driveway, directly from the front, side street, public alley, or rear lane.
  - (3) On-site loading space(s) is not required.

C. **Driveways**

(1) **Access to Driveways**

- (a) Driveway access to and from developments of two or fewer dwelling units onto public streets shall be where practical by forward motion of the vehicle; and
- (b) Driveway access to and from developments of three or more dwelling units onto public streets shall be by forward motion of the vehicle.
- (c) Minimum 30 feet separation between driveways for all uses except developments of two or fewer dwelling units.

(2) **Number of Driveways.** Table D (Number of Driveways) specifies the maximum number of driveways for a development site based on the amount of lot frontage along arterial streets.

(3) Driveways shall be setback from design site lines as follows:

- (a) For front access, minimum two feet from side design site lines; and/or
- (b) For side street access, no less than the minimum rear parking setback per the zone; and/or
- (c) Where driveway access is shared by abutting design sites, Subsections (a) and (b) above do not apply; minimum two feet from building(s), and in compliance with Tiburon Fire Protection District.

(4) Driveways shall extend to and include the area between the design site line and the edge of the street pavement.

(5) The design and construction of all on-site parking access drives shall be in compliance with Marin Uniform Construction Standards.

Table 22.05.040.D: Number of Driveways	
Lot Frontage	Maximum Number of Driveways
Up to 150'	1
150' to 299'	2
Each additional 300'	1

D. **Tandem Parking.** Tandem parking is allowed in all zones for all uses, subject to on-site management.

E. **Compact Spaces.** In parking lots with more than 10 spaces, up to 25 percent of the total number of spaces may be designate as compact spaces. Each compact space shall be a minimum 16 feet in length and a minimum 7.5 feet in width.

F. **Identification as to Purpose and Location.** On-site parking areas of four or more spaces shall include painted lines, wheel stops, or other methods of identifying individual parking spaces and loading areas, while distinguishing such spaces from aisle and other circulation features.



**G. Materials**

- (1) All on-site parking areas and driveways shall be surfaced only with the following materials, in compliance with Tiburon Fire Protection District:
  - (a) Gravel, crushed granite, "grasscrete";
  - (b) Recycled materials including, but not limited to, glass, rubber, used asphalt, brick, block and concrete; or
  - (c) A combination of the above materials.
- (2) The perimeter of the parking area shall be improved with impervious materials, exclusive of required landscaping in Table E (Required Parking Lot Landscaping), and in compliance with Section 20.04.210 (Landscape Plans—Materials).

**H. Landscaping.** The landscaping standards identified in Table E (Required Parking Lot Landscaping) shall be applied with the standards of Section 22.05.020 (Screening) and Section 22.05.030 (Landscaping and Lighting).

- (1) Parking and loading areas shall be screened from adjacent residential zones by a six foot wall, fence, or evergreen.
- (2) Screening is not required when parking area(s) is adjacent to an alley.
- (3) Landscaping areas shall integrate stormwater management features per Marin County Stormwater Pollution Prevention Program (MCSTOPP).
- (4) For portions of parking areas covered by photo-voltaic solar collectors that also function as shade structures, the minimum standard for trees does not apply.

**I. Location**

- (1) Location of on-site parking is regulated by the required setbacks in Subsection 7 of the zone and the following:
  - (a) Parking lots with 11-20 spaces shall be separated at least by five feet from buildings to make room for a sidewalk, landscaping, and/or other planting between the building and the parking area;
  - (b) Parking lots with more than 20 spaces shall be separated by at least 12 feet from buildings to make room for a sidewalk, landscaping, and other planting between the building and the parking area; and
  - (c) The required separation may be eliminated to the rear of buildings in areas designed for unloading and loading of materials.

**Table 22.05.040.E: Required Parking Lot Landscaping**

<b>Number of Parking Spaces</b>	<b>Percent of Gross Parking Area Required to be Landscaped</b>
10 or fewer	None
11 to 20	5' min. wide planter along property line
21 to 50	5%; 5' min. wide planter between every 5 spaces, property line, and building(s)
51 and over	10%; 5' min. wide planter between every 5 spaces, property line, and building(s)
<b>General Landscaping</b>	
Required Border	6" high curb or equivalent
Border and Stormwater	Curb or equivalent shall include breaks every 4" to provide drainage to retention and filtration areas.
Car Overhangs	Shall be prevented by stops
Required Quantity	1 tree per every 10 parking spaces, beginning at 11 total spaces
Tree Well Size <sup>1</sup>	5' min. in any direction
Tree Can Size	15 gallon min.
Tree Box Size	20% of required trees shall be 24" min.
Tree Caliper	1" min.
Tree Height at Installation	7' min. vertical clearance
Tree Characteristics	High branching, broad headed, shading form
Location	Evenly spaced throughout parking lot to provide uniform shade

<sup>1</sup>Any vehicle overhang requires the minimum planter area width to be expanded by an equivalent dimension.

- J. **Size of Parking Lot.** Parking lots larger than 10,000 square feet in size shall be broken down into smaller parking areas with planted landscape areas with a minimum width of 15 feet between them to minimize the perceived scale of the total field of stalls.

## 22.05.050 Public Frontage Standards

1. **Intent.** Public frontage types provide a coordinated approach to design standards for the area between each design site's private frontage(s) and the adjoining right-of-way or private driveway easement. Public frontage types consist of planters, walkways, curbs, planters, planting and lighting, as illustrated in Table B (Public Frontage Types Overview).
2. **Required Improvements.** The public frontage along the design site(s) shall be improved per Table A (Required Improvements) and the development scenario that applies to the project.

**Table 22. 05.050.A: Required Improvements**

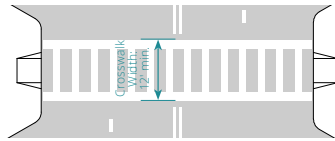
Required Improvements	Development Scenario			
	Infill Design Site on Existing Block	Two or More Design Sites on Existing Block	More Than Half of Existing Block	New Block(s)
	Development consists of one design site.	Development consists of two or more design sites that are less than half of the block face.	Development consists of two or more design sites that are more than half of the block face.	Development creates one or more new blocks.
a. <b>Sidewalk.</b> Add missing segment(s) along abutting front and/or side street.	R	R	R	R
b. <b>Sidewalk.</b> Repair uneven segments along abutting front and/or side street.	R	R	R	N/A
c. <b>Street trees.</b> Add street trees along abutting front and/or side street where there is adequate room to also maintain sufficient width for traffic lanes, pedestrian sidewalks, and bicycle facilities. See Subsection 22.05.030.4.A.(2).	R	R	R	R
d. <b>Crosswalk improvements.</b> Add crosswalk.	X	X	X	Including adjacent and new intersection(s).
e. <b>Bicycle facilities.</b> Add bicycle facilities required in Bicycle and Pedestrian Master Plan to the frontage of the development site. Not applicable to southwest side of San Rafael Avenue between Acacia Avenue and Beach Road.	X	X	X	Including bike lanes.

- 3. **Design Standards for Public Frontages.** Public frontages shall be designed and maintained in compliance with the following standards:
  - A. The required elements are identified in and shall be configured according to Table C (Public Frontage Assemblies) and in compliance with Marin Uniform Construction Standards.
  - B. Planting and landscape selection shall consist of native vegetation that is applicable to Marin County, in compliance with Water Use Classification of Landscape Species (WUCOL IV).

4. **Pedestrian Crossings**

- A. **Curb Ramps.** Perpendicular corner curb ramps with a separate ramp installed in each direction are required.
- B. **Crosswalks.** Crosswalks shall be designed per the City's applicable standards and applicable State guidelines and standards.

(1) Standard Crosswalk.



5. **Allowed Public Frontage Types**

- A. **Street.** The Street Frontage includes raised curbs drained by inlets with sidewalks separated from vehicular lanes by individual or continuous planters. Landscaping consists of street trees of a single or alternating species aligned and spaced at 35' intervals on average.
- B. **Avenue/Boulevard.** The Avenue/Boulevard Frontage has raised curbs drained by inlets and wide sidewalks separated from the vehicular lanes by a continuous planter, with parking on both sides. Landscaping consists of single or double rows of a single or alternating tree species aligned and spaced at 35' intervals on average.
- C. **Main Street.** The Main Street Frontage includes raised curbs drained by inlets with very wide sidewalks along both sides separated from the vehicular lanes by individual tree wells with grates. Landscaping consists of a single tree species aligned and spaced at 35' intervals on average.

**Table 22.05.050.B: Public Frontage Types Overview**

Table B (Public Frontage Types Overview) provides an overview of the allowed public frontage types in or abutting each zone.

Public Frontage Types	Specific Standards	Zones		
		T3	T4	
		SN	SN.S	SMS.S
Street	22.05.050.C.1	P	P	X
Avenue/Boulevard	22.05.050.C.2	X	X	P
Main Street	22.05.050.C.3	X	X	P
<b>Key</b>	P = Allowed	X = Not Allowed		

**Table 22.05.050.C: Public Frontage Assemblies**

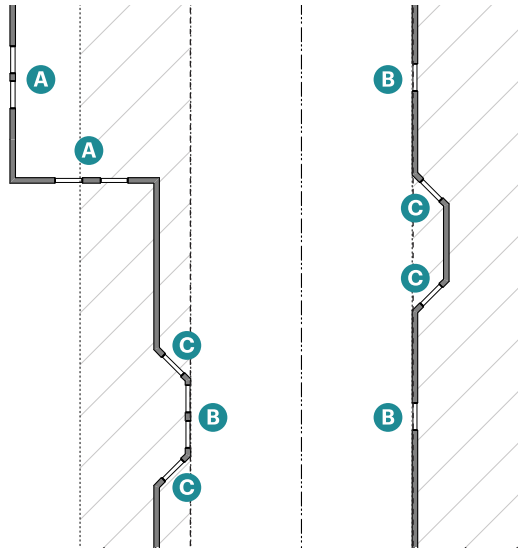
Table C (Public Frontage Assemblies) identifies the required elements and dimensions of each public frontage type.

	Street 22.05.050.C.1	Avenue/Boulevard 22.05.050.C.2	Main Street 22.05.050.C.3
<b>Assembly.</b> The type and dimension of curbs, walkways, and planters.			
Total Width	<b>A</b> 11' min.	<b>A</b> 13' min.	<b>A</b> 16' min.
Note: See below for required elements of each assembly			
a. <b>Curb.</b> The detailing of the edge of the vehicular pavement, incorporating drainage.			
i. Type	Raised Curb	Raised Curb	Raised Curb
b. <b>Walkway.</b> The pavement dedicated exclusively to pedestrian activity.			
i. Type	Walkway	Walkway	Walkway
ii. Width	6' min.	8' min.	12' min.
Note: Placement of curb ramps shall match the desired path of pedestrian travel. See Marin County Uniform Construction Standards for curb ramp design.			
c. <b>Planter.</b> The area that accommodates street trees and other landscaping.			
Arrangement	Regular	Regular	Regular
Types	Planting Strips along curb edge and R.O.W. edge	Planting Strips along curb	Tree Wells (must be located between walkway and curb)
Width	5' min.	5' min.	4' min.

## 22.05.060 Privacy Standards

1. **Intent.** These standards are designed to provide privacy between primary living spaces of buildings on each side of a design site line in T3 and T4 zones. Windows and balconies along the side of a building within 20 feet of an interior side design site line in T3SN or T4SN.S zones are subject to these standards.
2. **Standards**
  - A. Primary living spaces adjoining a side setback shall orient principal/main windows/glazed openings toward the front and rear of the building.
  - B. Windows and balconies within 10 feet of and oriented to an interior design site setback:
    - (1) Shall have a minimum sill height of five feet unless the window is placed at an angle of at least 30 degrees, measured perpendicular to the adjacent side design site line.

**Figure 22.05.060.1: Sill Height Standards along Interior Design Site Line**



### Key

- -	Design Site Line
....	Side Yard Setback Line
////	10' of Design Site Line
<b>A</b>	Principal Window
<b>B</b>	5' min. Sill Height
<b>C</b>	No Limitation on Sill Heights

# Chapter 6: Specific to Building Types

---

## Sections:

22.06.010	Purpose
22.06.020	Building Types
22.06.030	Overview of Building Types
22.06.040	Carriage House
22.06.050	House
22.06.060	Duplex Side-by-Side
22.06.070	Duplex Stacked
22.06.080	Cottage Court
22.06.090	Fourplex
22.06.100	Neighborhood Townhouse
22.06.110	Neighborhood Courtyard
22.06.120	Pocket Neighborhood
22.06.130	Multiplex
22.06.140	Main Street Building

---

## 22.06.010 Purpose

This Chapter provides the standards for development of individual building types to achieve the intended physical character of each zone, offer housing choices and affordable housing opportunities, and incubate small businesses as amenities within walkable neighborhoods.

---

## 22.06.020 Building Types

1. Building types are used to articulate size, scale, and intensity according to the intent of each zone.
2. Building types are categorized into two groups: House-Scale Buildings and Block-Scale Buildings. See Figure 1 (Example of House-Scale and Block-Scale Buildings) for examples.
  - A. **House-Scale Buildings.** Buildings that are the size of a house, typically ranging in footprint from as small as 25 feet up to 80 feet overall; and
  - B. **Block-Scale Buildings.** Buildings that are individually as large as most or all of a block or, when arranged together along a street, appear as long as most or all of a block.
3. The design site size standards for each building type are set in each zone to generate pedestrian-oriented buildings within the overall intended physical character of each zone. The design site size standard identifies the range of design site sizes on which the given building type is allowed to be built.
4. Certain building types have additional standards beyond the zone standards to further calibrate the type for its context.

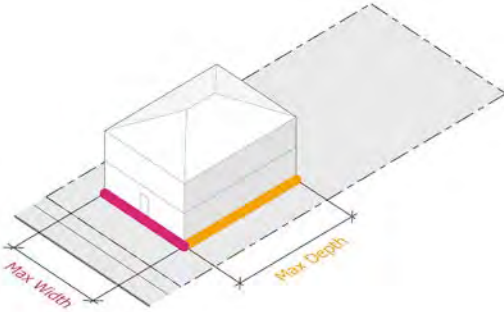
5. Each design site shall have only one primary building type, except as follows, and in compliance with all standards:
  - A. Where allowed by the zone, one Carriage House (Section 22.06.040) is allowed in addition to the primary building type;
  - B. The Cottage Court (Section 22.06.080) may consist of up to nine individual buildings;
  - C. The Pocket Neighborhood (Section 22.06.120) may consist of up to five buildings; and
  - D. More than one building type is allowed on a parcel that identifies proposed multiple design site lines that meet the standards of this Section. See Figure 2 (Example of Multiple Design Sites on One Parcel).
    - (1) Examples:
      - (a) A parcel large enough to accommodate multiple design sites but smaller than the size of a block; or
      - (b) A parcel large enough to create one or more new blocks.
6. On-site open space. The standards identify only the required type (private or common) and amount. For example, if the type only has standards for private open space, common open space is not required for that building type. The identified amount is for the entire building unless specified otherwise.
7. Parking may be designed as tuck-under, detached garage(s), podium or subterranean, in compliance with the zone standards for parking placement.
8. Wings are required to be smaller in size and height than the main body to visually reduce the overall size of a building. To further this objective, the standards specify the amount that wings are required to be offset from the main body so that their facades are not aligned. Wings may be the same number of stories and height as the main body when a density bonus is applied to the building.
9. The maximum number of units identified for each building type is dependent on the design site being large enough to accommodate the zone's standards (e.g., parking).
10. Individual designs may vary from the diagrams for each building type in compliance with the standards of this Chapter and Chapter 8 (Specific to Architectural Design).
11. New buildings and their improvements are subject to the City's local standards for Fire Safety and Building Safety.



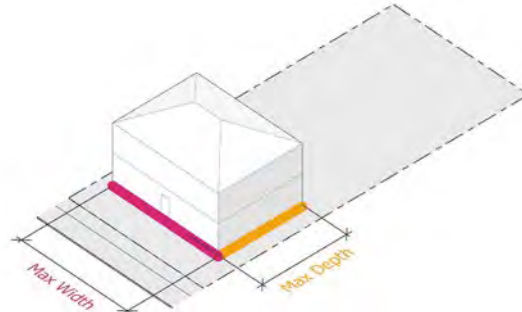
Figure 22.06.020.1 Example of House-Scale and Block-Scale Buildings

**House-Scale Buildings**

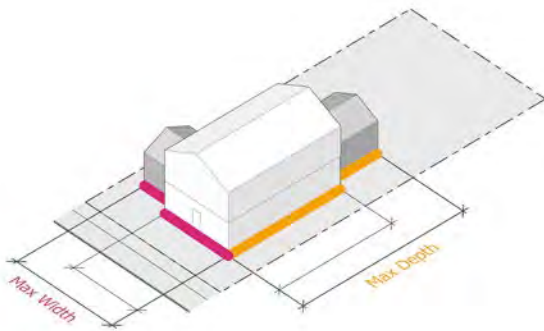
*Main body only*



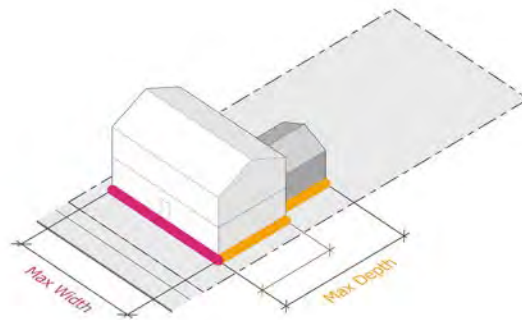
*Main body only*



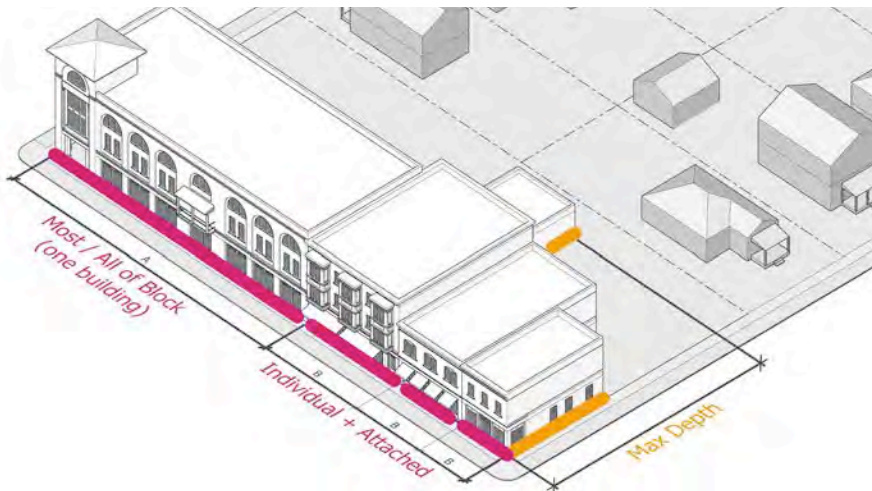
*Main body with side and rear wings*



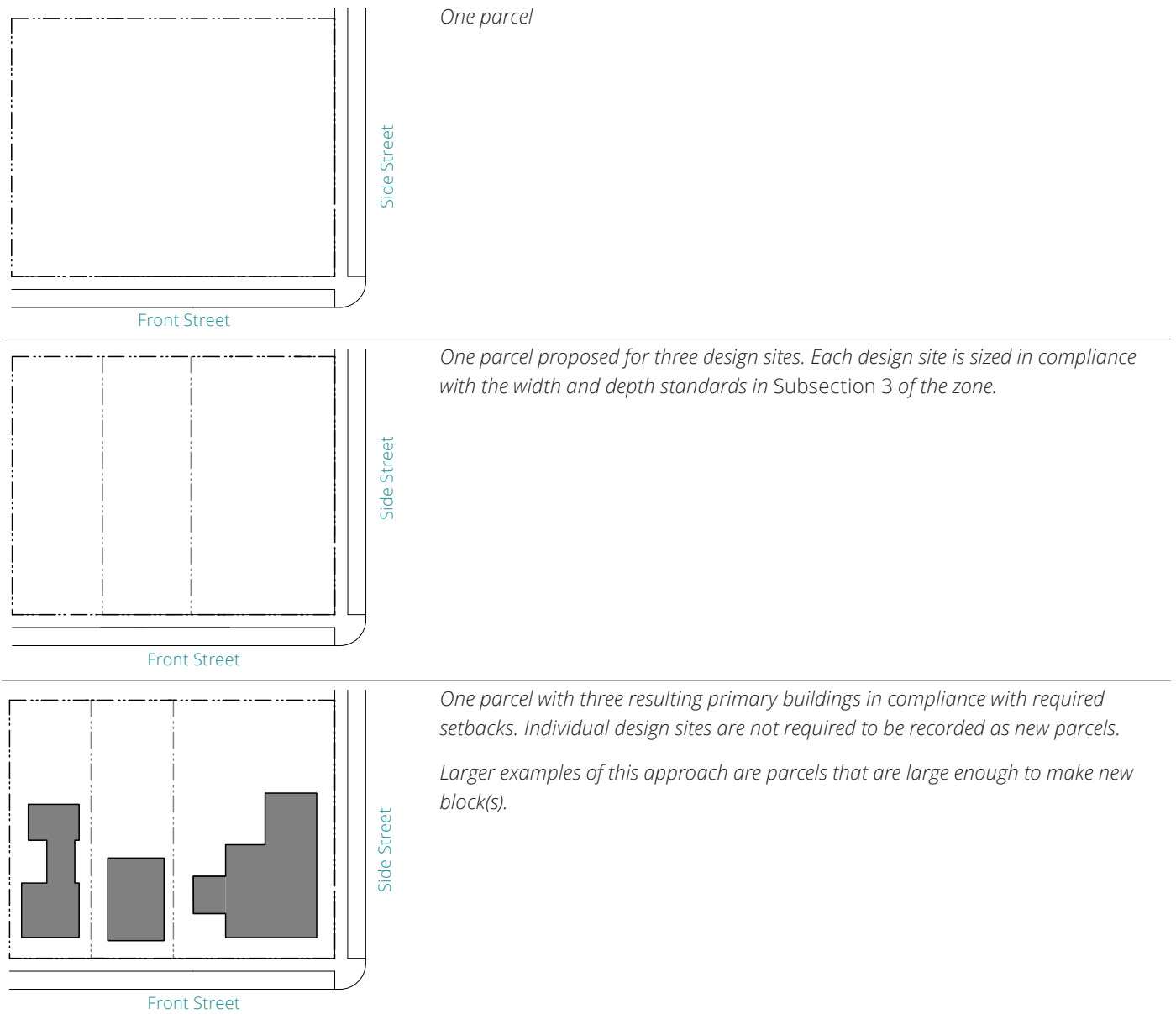
*Main body with rear wing*



**Block-Scale Buildings**



**Figure 22.06.020.2 Example of Multiple Design Sites on One Parcel**



**Key**

- · - · - Parcel Line
- - - - Design Site Line
- Primary Building Type

## 22.06.030 Overview of Building Types

Table A ( Building Types Overview) provides an overview of the allowed building types in each zone. The names of the building types are not intended to limit uses within a building type. For example, a Duplex may have non-residential uses within it as allowed by the zone.

Table 22.06.030.A: Building Types Overview				
	Specific Standards	Zones		
		T3	T4	
		SN	SN.S	SMS.S
<b>House Scale</b>				
Carriage House	22.06.040	P	P	P
House	22.06.050	P	P	P
Duplex Side-by-Side	22.06.060	P	X	X
Duplex Stacked	22.06.070	X	P	X
Cottage Court	22.06.080	P	P	X
Fourplex	22.06.090	P	P	X
Neighborhood Townhouse	22.06.100	P	P	P
Neighborhood Courtyard	22.06.110	X	P	P
Pocket Neighborhood	22.06.120	P	P	X
Multiplex	22.06.130	X	P	P
<b>Block Scale</b>				
Main Street Building	22.06.140	X	X	P

**Key** P = Allowed X = Not Allowed

*This page intentionally left blank*

**22.06.040 Carriage House**



Example of Carriage House



Example of Carriage House



Example of Carriage House

**1. Description**

An accessory structure located at the rear of a design site, above or abutting a detached garage that provides a small residential unit (accessory apartment), home office space, or other small commercial or service use, as allowed by the zone. When used for residential purposes, this housing type is one form of an Accessory Dwelling Unit (ADU).

Synonym: Granny Flat

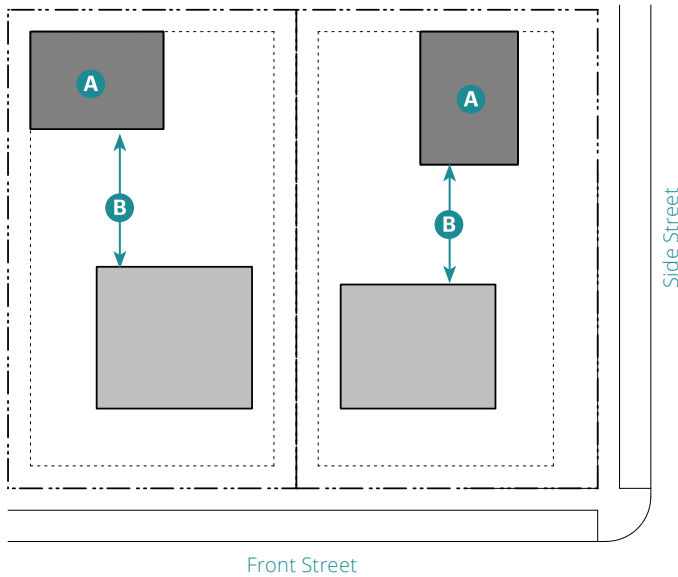
**2. Number of Units**

Units per Building	1 max.
Carriage Houses per Design Site	1 max.

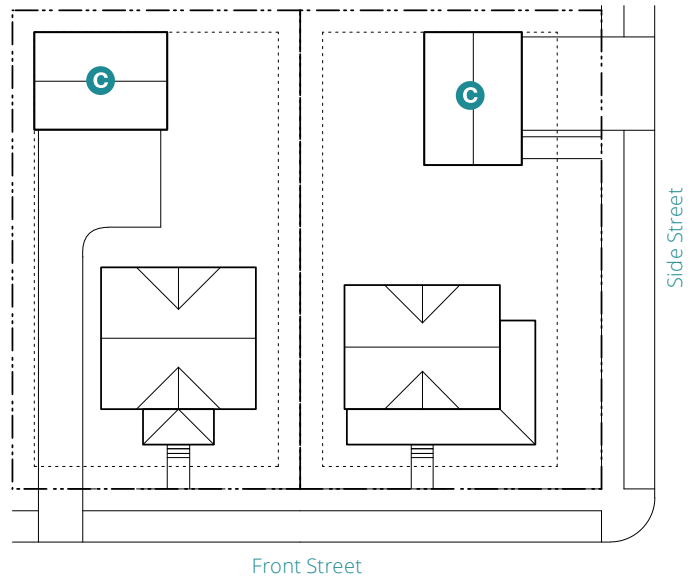
Not allowed on the design site of a Cottage Court

*General Note: Photos on this page are illustrative, not regulatory.*

Alley access required if alley exists



Alley access required if alley exists



**Key**

- - - ROW/ Design Site Line
- ..... Building Setback Line
- Carriage House
- Primary Building Type

**3. Building Size and Massing**

**Height**

Stories 2.5 max.<sup>1</sup>

**Main Body<sup>2</sup>**

Area 800 sf max. **A**

Depth 24' max.

Separation from Primary Building<sup>3</sup> 10' min. **B**

<sup>1</sup> Includes garage story

<sup>2</sup> In compliance with the setbacks of the zone

<sup>3</sup> A Carriage House may be connected to the primary building by an uninhabitable space including, but not limited to, a breezeway.

**Key**

- - - ROW/ Design Site Line
- ..... Building Setback Line
- Frontage

**4. Pedestrian Access**

The main entrance shall not be through a garage.

**5. Vehicle Access and Parking**

Driveway and parking location shall comply with standards in Subsection 7 of the zone. **C**

Parking may be covered, uncovered, or in a garage.

**6. Open Space**

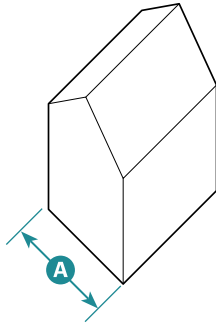
**Private Open Space**

Not required

**7. Main Body Massing Composition**

Select from the allowed massing proportions and apply the standards to the main body width in compliance with Chapter 8 (Specific to Architectural Design) and the following standards.

**Front Gable**



This massing type is a simple rectilinear form that is square or deeper than it is long. The roof is sloped and may be either hipped or gabled.

Number of Bays	Flexible	A
Main Body Width	Max. allowed by Subsection 3 of this building type	

*This page intentionally left blank*



**22.06.050 House**



Example of House



Example of House



Example of House

**1. Description**

A small-to-medium-sized, detached, House-Scale Building with one unit, small-to-medium setbacks, a rear setback, and located within a low-intensity, walkable neighborhood.

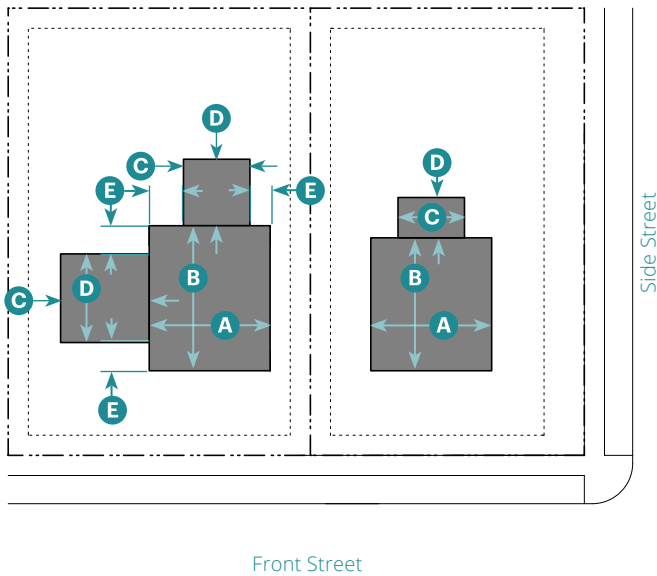
**2. Number of Units**

Units per Building	1 max.
Buildings per Design Site	1 max. <sup>1</sup>

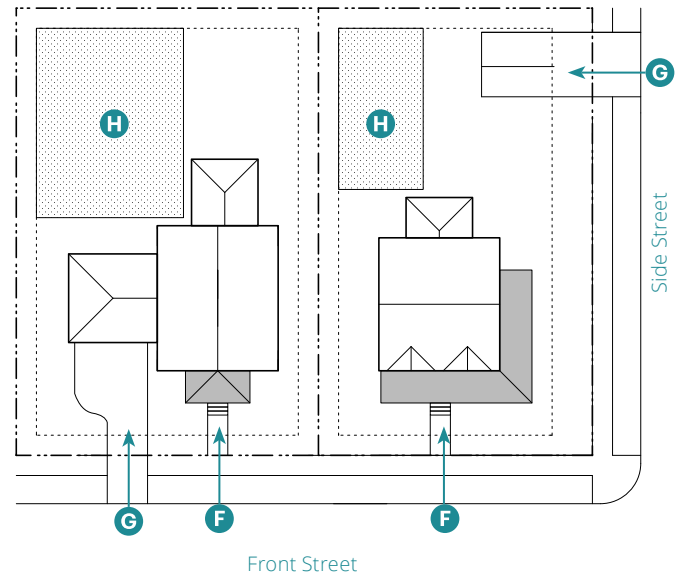
<sup>1</sup> Not including ADU

*General Note: Photos on this page are illustrative, not regulatory.*

Alley access required if alley exists



Alley access required if alley exists



**Key**

- ROW/ Design Site Line
- Building Setback Line
- Building

**3. Building Size and Massing**

**Height**

Stories 2.5 max.

**Main Body<sup>4</sup>**

Width 36' max. **(A)**

Depth 48' max. **(B)**

**Wing(s)<sup>3,4</sup>**

Width 20' max. **(C)**

Depth 20' max. **(D)**

Separation between Wings 15' min.

Offset from Main Body 5' min. **(E)**

Facades shall be designed in compliance with Chapter 8 (Specific to Architectural Design).

<sup>3</sup>In compliance with Subsection 5 of the zone

<sup>4</sup>Height is limited to 1 story less than main body and 10' less to highest eave/parapet.

**Key**

- ROW/ Design Site Line
- Building Setback Line
- Frontage
- ▨ Private Open Space

**4. Pedestrian Access**

Main Entrance Location Front Street **(F)**

**5. Vehicle Access and Parking**

Driveway and parking location shall comply with standards in Subsection 7 of the zone. **(G)**

Parking may be covered, uncovered, or in a garage.

**6. Open Space**

**Private Open Space**

Area 300 sf min. **(H)**

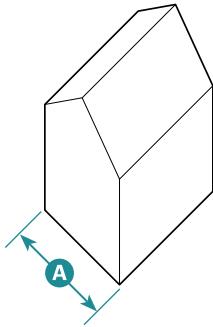
Required setbacks and driveways do not count toward open space.

Required private open space shall be located behind the main body of the building.

**7. Main Body Massing Composition**

Select from the allowed massing proportions and apply the standards to the main body width in compliance with Chapter 8 (Specific to Architectural Design) and the following standards.

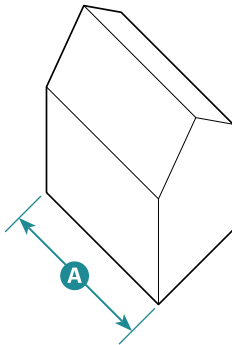
**Front Gable**



This massing type is a simple rectilinear form that is deeper than it is long. The roof is sloped and may be either hipped or gabled.

Number of Bays	3-5 bays	A
Main Body Width	Max. allowed by Subsection 3 of this building type	

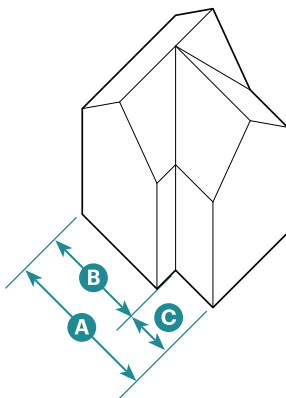
**Side Gable**



This massing type is a simple rectilinear form that is longer than it is deep. The roof is sloped and may be either hipped or gabled.

Number of Bays	3-5 bays	A
Main Body Width	Max. allowed by Subsection 3 of this building type	

**Gable L (2/3 + 1/3)**



This massing type divides the facade into three equal parts, 1 part projecting and 2/3 as a wing. The roof is sloped with a gable at the projecting 1/3.

Number of Bays	3 bays	A
Main Body Width	Max. allowed by Subsection 3 of this building type	
Massing Proportions	2/3	B
	1/3	C



22.06.060 Duplex Side-by-Side



Example of Duplex Side-by-Side



Example of Duplex Side-by-Side



Example of Duplex Side-by-Side

**1. Description**

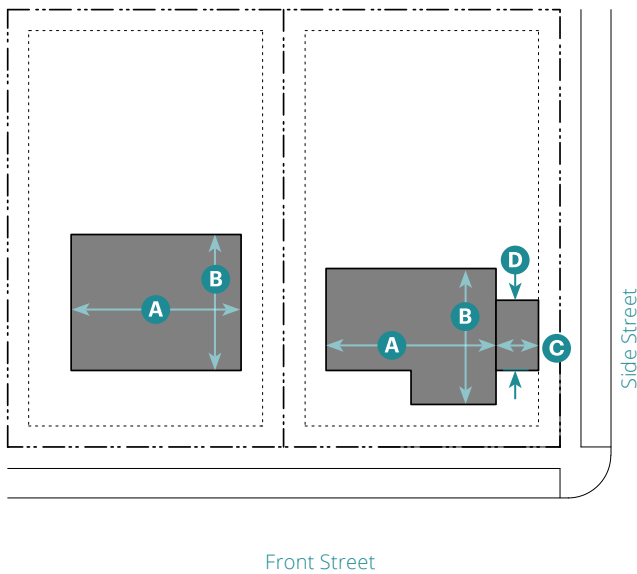
A small-to-medium-sized, detached, House-Scale Building with small-to-medium setbacks and a rear setback. The building consists of two side-by-side units, both facing the street and within a single Building massing. The type has the appearance of a medium-to-large, single-unit house and is scaled to fit within lower-intensity neighborhoods.

**2. Number of Units**

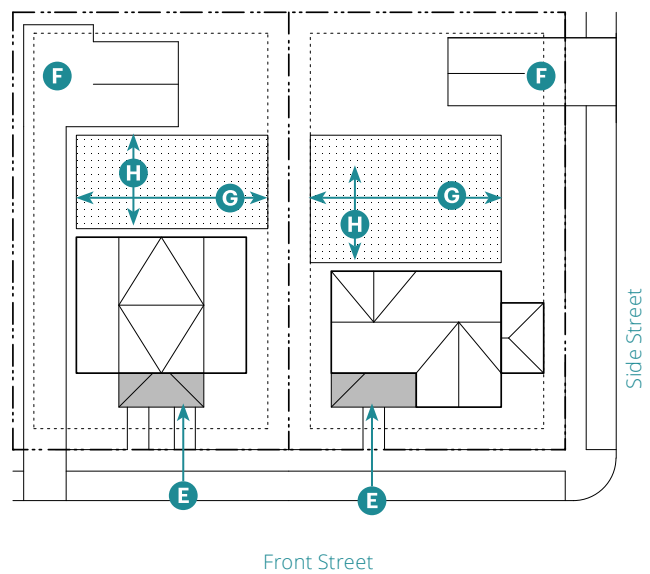
Units per Building	2 max.
Buildings per Design Site	1 max.

*General Note: Photos on this page are illustrative, not regulatory.*

Alley access required if alley exists



Alley access required if alley exists



**Key**

- - - - ROW/ Design Site Line
- ..... Building Setback Line
- Building

**3. Building Size and Massing**

Height	
Stories	2.5 max.
Main Body <sup>1</sup>	
Width	48' max. <b>(A)</b>
Depth	36' max. <b>(B)</b>
Wing(s) <sup>1,2</sup>	
Width	15' max. <b>(C)</b>
Depth	24' max. <b>(D)</b>
Separation between Wings	15' min.
Offset from Main Body	5' min.

Facades shall be designed in compliance with Chapter 8 (Specific to Architectural Design).

<sup>1</sup> In compliance with Subsection 5 of the zone  
<sup>2</sup> Height is limited to 1 story less than main body and 10' less to highest eave/parapet.

**Key**

- - - - ROW/ Design Site Line
- ..... Building Setback Line
- Frontage
- ▨ Private Open Space

**4. Pedestrian Access**

Main Entrance Location Front Street<sup>3</sup> **(E)**

Each unit shall have an entry facing the street on or within 15' of the front facade.

<sup>3</sup> On corner design sites, each unit shall front a different street.

**5. Vehicle Access and Parking**

Driveway and parking location shall comply with standards in Subsection 7 of the zone. **(F)**

Parking may be covered, uncovered, or in a garage.

**6. Open Space**

Common Open Space	
Width	15' min. <b>(G)</b>
Depth	15' min. <b>(H)</b>

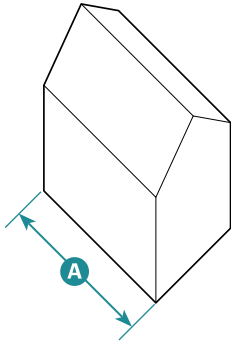
Required setbacks and driveways do not count toward open space.

Required private open space shall be located behind the main body of the building.

**7. Main Body Massing Composition**

Select from the allowed massing proportions and apply the standards to the main body width in compliance with Chapter 8 (Specific to Architectural Design) and the following standards.

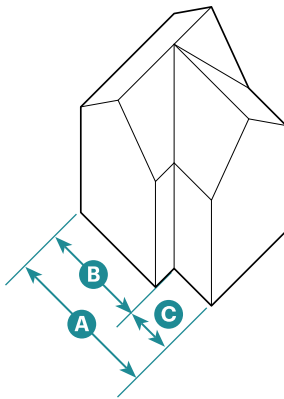
**Side Gable**



This massing type is a simple rectilinear form that is longer than it is deep. The roof is sloped and may be either hipped or gabled.

Number of Bays	3-6 bays	A
Main Body Width	Max. allowed by Subsection 3 of this building type	

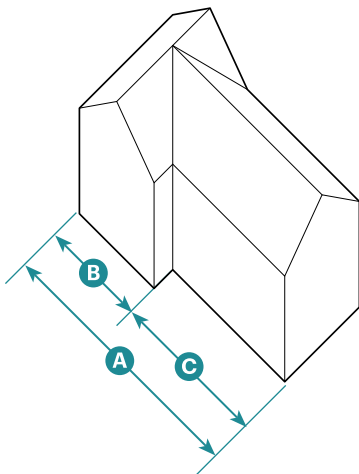
**Gable L (2/3 + 1/3)**



This massing type divides the facade into three equal parts, 1 part projecting and 2/3 as a wing. The roof is sloped with a gable at the projecting 1/3.

Number of Bays	3-6 bays	A
Main Body Width	Max. allowed by Subsection 3 of this building type	
Massing Proportions	2/3	B
	1/3	C

**Gable L (2/5 + 3/5)**

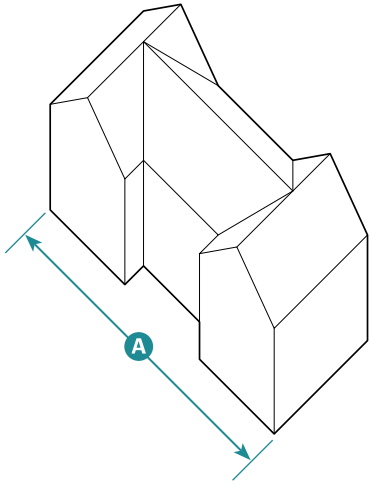


This massing type divides the facade into five equal parts, with two parts projecting and three parts set back to create a shallow forecourt. The roof is sloped with gables at the projecting two parts.

Number of Bays	3-6 bays	A
Main Body Width	Max. allowed by Subsection 3 of this building type	
Massing Proportions	2/5	B
	3/5	C

### 7. Main Body Massing Composition (Continued)

#### Twin Gable



This massing type divides the facade into three parts, with the middle part set back slightly to create a shallow open space. The roof is sloped and may be either hipped or gabled.

Number of Bays	3-6 bays	A
Main Body Width	Max. allowed by Subsection 3 of this building type	

*This page intentionally left blank*



**22.06.070 Duplex Stacked**



*Example of Duplex Stacked*



*Example of Duplex Stacked*



*Example of Duplex Stacked*

**1. Description**

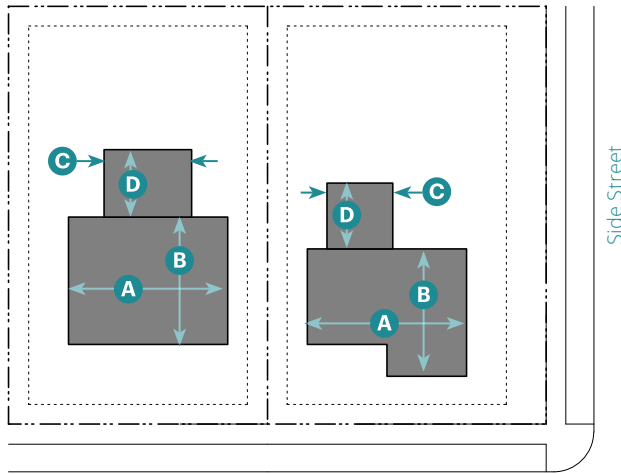
A small-to-medium-sized, detached, House-Scale Building with small-to-medium setbacks and a rear setback. The building consists of two stacked units, both facing the street and within a single building massing. The type has the appearance of a medium-to-large, single-unit house and is scaled to fit within lower-intensity neighborhoods.

**2. Number of Units**

Units per Building	2 max.
Buildings per Design Site	1 max.

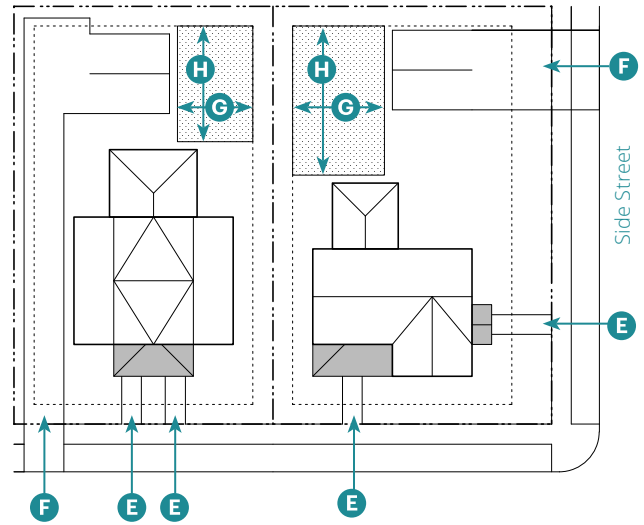
*General Note: Photos on this page are illustrative, not regulatory.*

Alley access required if alley exists



Front Street

Alley access required if alley exists



Front Street

**Key**

- - - - ROW/ Design Site Line
- ..... Building Setback Line
- Building

**3. Building Size and Massing**

**Height**

Stories 2.5 max.

**Main Body<sup>1</sup>**

Width 36' max. **(A)**

Depth 48' max. **(B)**

**Wing(s)<sup>1,2</sup>**

Width 15' max. **(C)**

Depth 24' max. **(D)**

Separation between Wings 15' min.

Offset from Main Body 5' min.

Facades shall be designed in compliance with Chapter 8 (Specific to Architectural Design).

<sup>1</sup> In compliance with Subsection 5 of the zone

<sup>2</sup> Height is limited to 1 story less than main body and 10' less to highest eave/parapet.

**Key**

- - - - ROW/ Design Site Line
- ..... Building Setback Line
- Frontage
- ▨ Private Open Space

**4. Pedestrian Access**

Main Entrance Location Front Street<sup>3</sup> **(E)**

Each unit shall have an entry facing the street on or within 15' of the front facade.

<sup>3</sup> On corner design sites, each unit shall front a different street.

**5. Vehicle Access and Parking**

Driveway and parking location shall comply with standards in Subsection 7 of the zone. **(F)**

Parking may be covered, uncovered, or in a garage.

**6. Open Space**

**Private Open Space**

Width 15' min. **(G)**

Depth 15' min. **(H)**

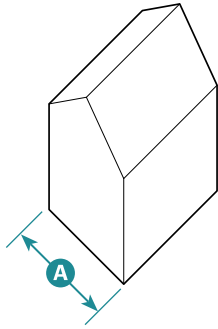
Required setbacks and driveways do not count toward open space.

Required private open space shall be located behind the main body of the building.

**7. Main Body Massing Composition**

Select from the allowed massing proportions and apply the standards to the main body width in compliance with Chapter 8 (Specific to Architectural Design) and the following standards.

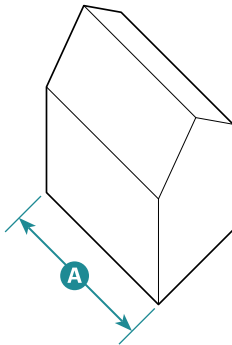
**Front Gable**



This massing type is a simple rectilinear form that is deeper than it is long. The roof is sloped and may be either hipped or gabled.

Number of Bays	2-3 bays	A
Main Body Width	Max. allowed by Subsection 3 of this building type	

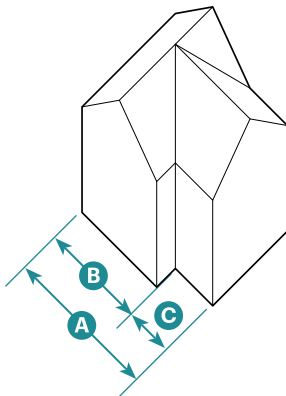
**Side Gable**



This massing type is a simple rectilinear form that is longer than it is deep. The roof is sloped and may be either hipped or gabled.

Number of Bays	3-5 bays	A
Main Body Width	Max. allowed by Subsection 3 of this building type	

**Gable L (2/3 + 1/3)**



This massing type divides the facade into three equal parts, 1 part projecting and 2/3 as a wing. The roof is sloped with a gable at the projecting 1/3.

Number of Bays	2-3 bays	A
Main Body Width	Max. allowed by Subsection 3 of this building type	
Massing Proportions	2/3	B
	1/3	C

*This page intentionally left blank*



**22.06.080 Cottage Court**



Example of Cottage Court



Example of Cottage Court



Example of Cottage Court

**1. Description**

A group of up to nine small, detached, House-Scale Buildings arranged to define a shared court open to and visible from the street. The shared court is common open space and takes the place of a private rear setback, thus becoming an important community-enhancing element. The type is scaled to fit within low-to-moderate-intensity neighborhoods and in non-residential contexts.

Synonym: Bungalow Court

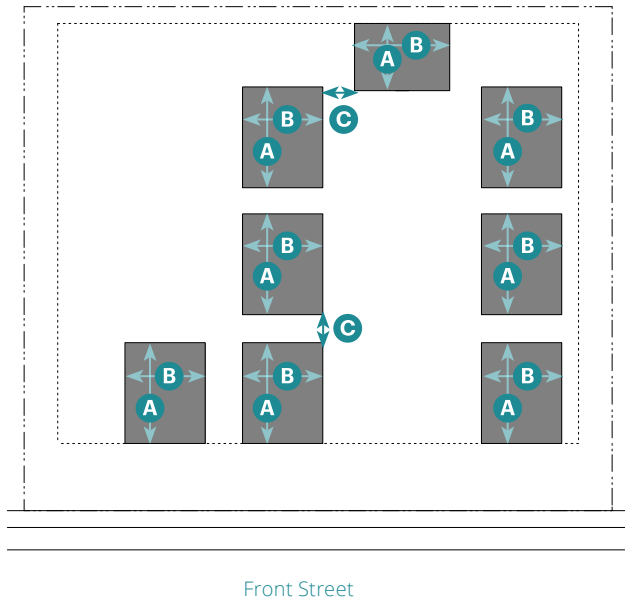
**2. Number of Units**

Units per Building	1 max.
Buildings per Design Site	3 min.; 9 max. <sup>1</sup>

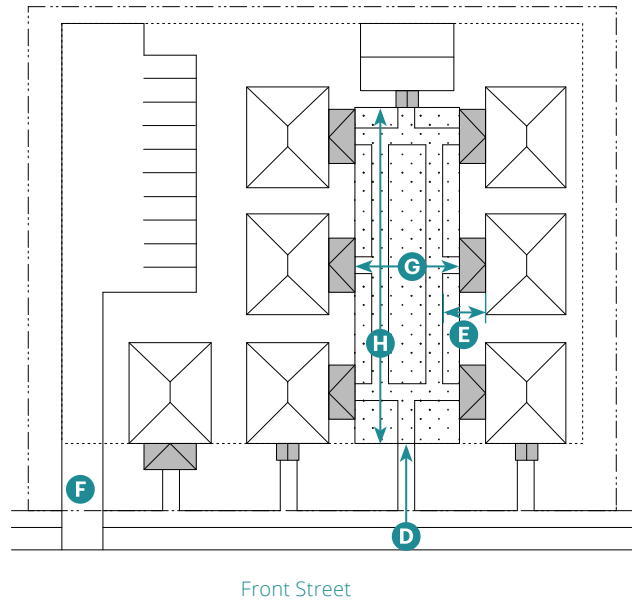
<sup>1</sup> In the T3SN and T4SN.S zones, the rearmost Cottage may contain up to 2 units, for a total of 10 units.

*General Note: Photos on this page are illustrative, not regulatory.*

Alley access required if alley exists



Alley access required if alley exists



**Key**

- - - - ROW/ Design Site Line
- ..... Building Setback Line
- Building

**3. Building Size and Massing**

**Height**

Stories	1.5 max.
To Highest Eave/parapet	18' max.

**Main Body<sup>2</sup>**

Width	32' max.	<b>(A)</b>
Depth	32' max.	<b>(B)</b>
Separation between Cottages	7' min.	<b>(C)</b>

**Wing(s)**

Not Allowed

**4. Pedestrian Access**

Shared court shall be accessible from front street. **(D)**

**Pedestrian Path Setbacks**

From Building Entrance 6' min. **(E)**

Main entrance to units required from shared court.

Units on a corner may enter from the side street.

Pedestrian connections shall connect all buildings to the public ROW, shared court, and parking areas.

Facades shall be designed in compliance with Chapter 8 (Specific to Architectural Design).

<sup>2</sup> In compliance with Subsection 5 of the zone

**Key**

- - - - ROW/ Design Site Line
- ..... Building Setback Line
- Frontage
- Common Open Space

**5. Vehicle Access and Parking**

Driveway and parking location shall comply with standards in Subsection 7 of the zone. **(F)**

Parking may be covered, uncovered, or in a garage.

Spaces may be individually accessible by the units and/or common parking area(s) at rear or side of design site.

**6. Open Space**

**Common Open Space**

Width	20' min. clear	<b>(G)</b>
Depth	75' min. (3-4 units)	<b>(H)</b>
	90' min. (5-9 units)	

Required setbacks and driveways do not count as open space.

Up to 1/3 of the shared court(s) may be used for stormwater management if designed as a rain garden or bioswale.

**7. Miscellaneous**

**Fencing**

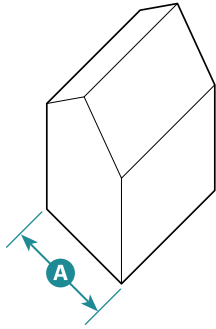
Fencing only allowed around or between individual buildings and shall not exceed 36" in height.

Visibility shall be maintained through the fencing.

**7. Main Body Massing Composition**

Select from the allowed massing proportions and apply the standards to the main body width for each building in compliance with Chapter 8 (Specific to Architectural Design) and the following standards.

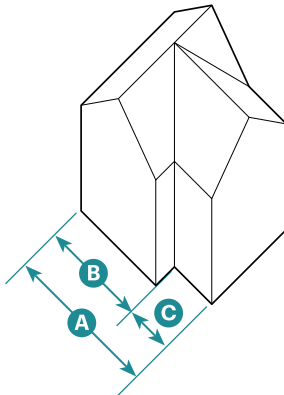
**Front Gable**



This massing type is a simple rectilinear form that is deeper than it is long. The roof is sloped and may be either hipped or gabled.

Number of Bays	2-3 bays	A
Main Body Width	Max. allowed by Subsection 3 of this building type	

**Gable L (2/3 + 1/3)**



This massing type divides the facade into three equal parts, 1 part projecting and 2/3 as a wing. The roof is sloped with a gable at the projecting 1/3.

Number of Bays	2-3 bays	A
Main Body Width	Max. allowed by Subsection 3 of this building type	
Massing Proportions	2/3	B
	1/3	C



22.06.090 Fourplex



Example of Fourplex



Example of Fourplex



Example of Fourplex

1. Description

A small-to-medium-sized, detached, House-Scale Building that consists of three to four side-by-side and/or stacked units, typically with one shared entry or individual entries along the front. The type has the appearance of a medium-sized, single-unit house and is scaled to fit within low- to moderate-intensity neighborhoods.

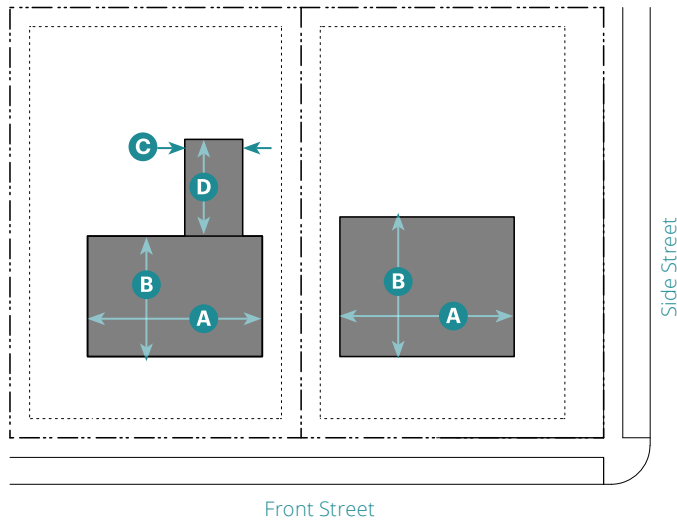
2. Number of Units

Units per Building	3 min.; 4 max.
Buildings per Design Site	1 max.

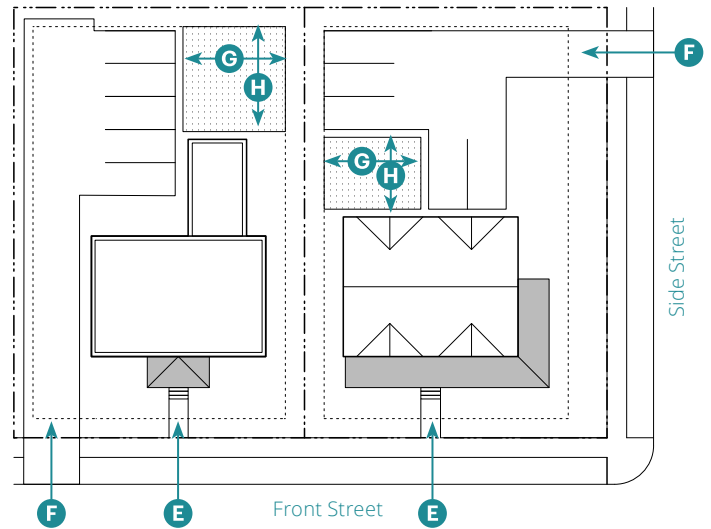
General Note: Photos on this page are illustrative, not regulatory.



Alley access required if alley exists



Alley access required if alley exists



**Key**

- - - - ROW/ Design Site Line
- ..... Building Setback Line
- Building

**3. Building Size and Massing**

**Height**

Stories 2.5 max.

**Main Body<sup>1</sup>**

Width 48' max. **(A)**

Depth 48' max. **(B)**

**Wing(s)<sup>1,2</sup>**

Width 15' max. **(C)**

Depth 20' max. **(D)**

Separation between Wings 15' min.

Offset from Main Body 5' min.

Facades shall be designed in compliance with Chapter 8 (Specific to Architectural Design).

<sup>1</sup> In compliance with Subsection 5 of the zone

<sup>2</sup> Height is limited to 1 story less than main body and 10' less to highest eave/parapet.

**Key**

- - - - ROW/ Design Site Line
- ..... Building Setback Line
- Frontage
- Common Open Space

**4. Pedestrian Access**

Main Entrance Location Front Street **(E)**

Each unit may have an individual entry.

**5. Vehicle Access and Parking**

Driveway and parking location shall comply with standards in Subsection 7 of the zone. **(F)**

Parking may be covered, uncovered, or in a garage.

**6. Open Space**

**Common Open Space<sup>3</sup>**

Width 15' min. **(G)**

Depth 15' min. **(H)**

Required setbacks and driveways do not count toward open space.

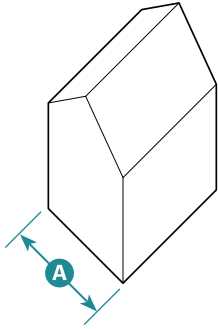
Required common open space shall be located behind the main body of the building.

<sup>3</sup> None is required if the building is within 800' of public open space

**7. Main Body Massing Composition**

Select from the allowed massing proportions and apply the standards to the main body width in compliance with Chapter 8 (Specific to Architectural Design) and the following standards.

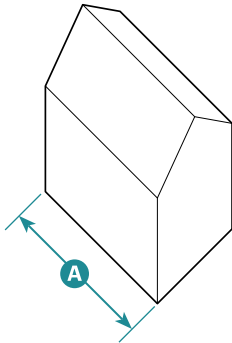
**Front Gable**



This massing type is a simple rectilinear form that is deeper than it is long. The roof is sloped and may be either hipped or gabled.

Number of Bays	Flexible	A
Main Body Width	Max. allowed by Subsection 3 of this building type	

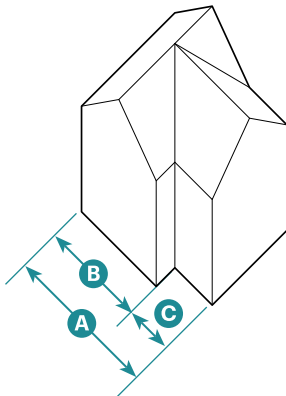
**Side Gable**



This massing type is a simple rectilinear form that is longer than it is deep. The roof is sloped and may be either hipped or gabled.

Number of Bays	Flexible	A
Main Body Width	Max. allowed by Subsection 3 of this building type	

**Gable L (2/3 + 1/3)**

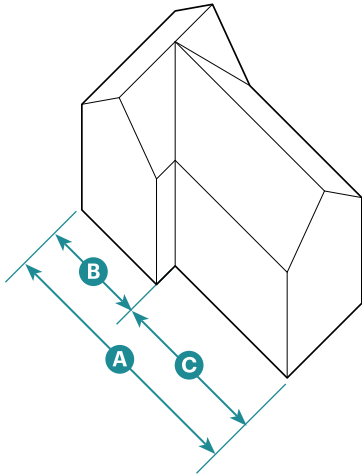


This massing type divides the facade into three equal parts, 1 part projecting and 2/3 as a wing. The roof is sloped with a gable at the projecting 1/3.

Number of Bays	3 bays	A
Main Body Width	Max. allowed by Subsection 3 of this building type	
Massing Proportions	2/3	B
	1/3	C

**7. Main Body Massing Composition (Continued)**

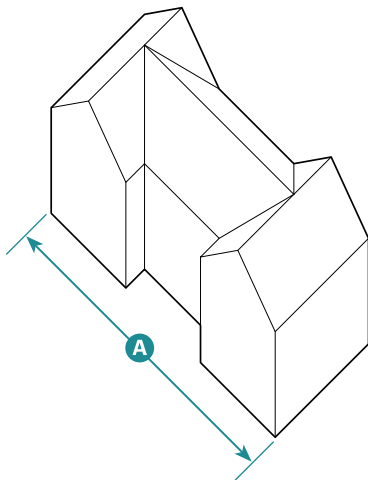
**Gable L (2/5 + 3/5)**



This massing type divides the facade into five equal parts, with two parts projecting and three parts set back to create a shallow forecourt. The roof is sloped with gables at the projecting two parts.

Number of Bays	3-6 bays	<b>A</b>
Main Body Width	Max. allowed by Subsection 3 of this building type	
Massing Proportions	2/5	<b>B</b>
	3/5	<b>C</b>

**Twin Gable**



This massing type divides the facade into three parts, with the middle part set back slightly to create a shallow open space. The roof is sloped and may be either hipped or gabled.

Number of Bays	3-6 bays	<b>A</b>
Main Body Width	Max. allowed by Subsection 3 of this building type	

*This page intentionally left blank*

**22.06.100 Neighborhood Townhouse**



*Example of Neighborhood Townhouse*



*Example of Neighborhood Townhouse*



*Example of Neighborhood Townhouse*

**1. Description**

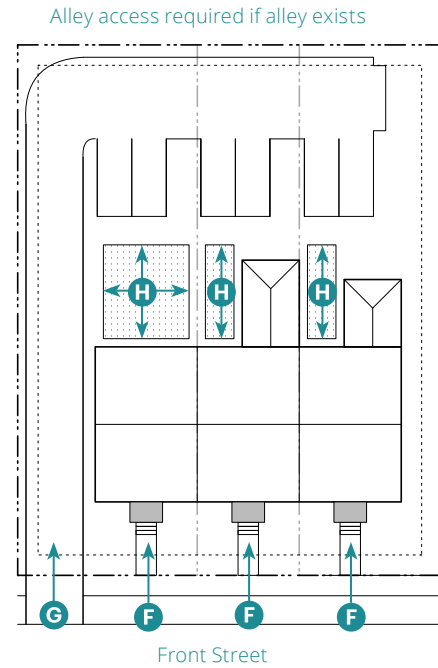
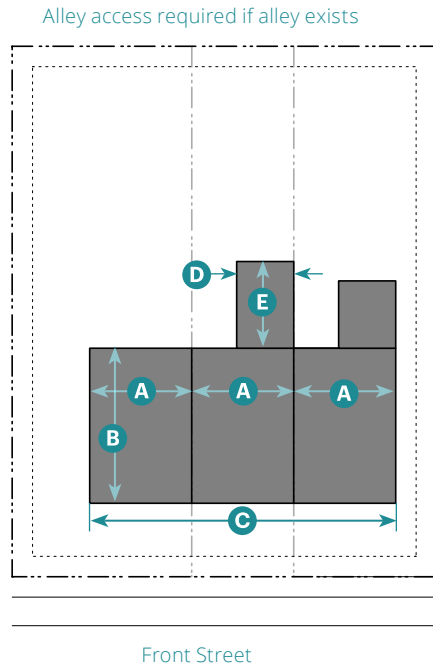
A small-sized, typically attached, House-Scale Building (up to four units side-by-side) with a rear setback. Each Neighborhood Townhouse consists of one unit. As allowed by the zone, the type may also be detached with minimal separations between buildings. The type is typically located within low-to-moderate-intensity neighborhoods.

Synonym: Rowhouse

**2. Number of Units**

Units per Building	2 max. (up to 6 side-by-side)
Buildings per Design Site	1 max.

*General Note: Photos on this page are illustrative, not regulatory.*



**Key**

- - - - ROW/ Design Site Line
- ..... Building Setback Line
- Building

**3. Building Size and Massing**

Height	T3SN	T4SN.S T4SMS.S
Stories	— 2.5 max. —	
<b>Main Body<sup>1</sup></b>		
Width per Unit <sup>2</sup>	24' min.; 30' max.	18' min. <b>(A)</b>
Depth per Unit <sup>2</sup>	— 40' max. — <b>(B)</b>	
Width per Building	100' max.	120' max. <b>(C)</b>
<b>Wing(s)<sup>1,3</sup></b>		
Width	— 14' max. — <b>(D)</b>	
Depth	— 25' max. — <b>(E)</b>	
Separation between Wings	— 15' min. —	
Offset from Main Body	— 5' min. —	

Facades shall be designed in compliance with Chapter 8 (Specific to Architectural Design).

<sup>1</sup>In compliance with Subsection 5 of the zone  
<sup>2</sup>Represents up to 2 stacked units  
<sup>3</sup>Height is limited to 1 story less than main body and 10' less to highest eave/parapet.

**Key**

- - - - ROW/ Design Site Line
- ..... Building Setback Line
- Frontage
- ▨ Private Open Space

**4. Pedestrian Access**

Main Entrance Location Front Street **(F)**  
 Each unit shall have an individual entry facing a street.

**5. Vehicle Access and Parking**

Driveway and parking location shall comply with standards in Subsection 7 of the zone. **(G)**  
 Parking may be covered, uncovered, or in a garage.

**6. Open Space**

<b>Private Open Space</b>		
Width	8' min.	<b>(H)</b>
Depth	8' min.	<b>(H)</b>

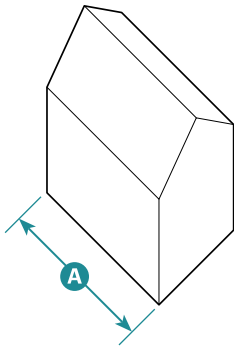
Required setbacks and driveways do not count toward open space.

Required private open space shall be located behind the main body of the building.

**7. Main Body Massing Composition**

Select from the allowed massing proportions and apply the standards to the main body width in compliance with Chapter 8 (Specific to Architectural Design) and the following standards.

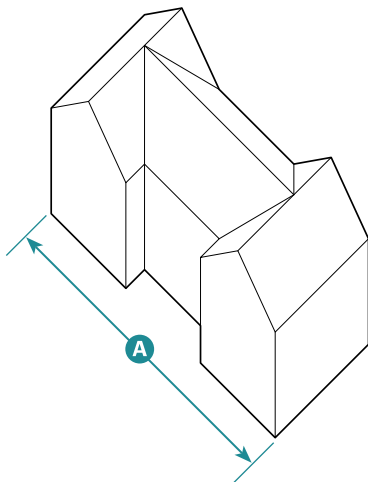
**Side Gable**



This massing type is a simple rectilinear form that is longer than it is deep. The roof is sloped and may be either hipped or gabled.

Number of Bays	Flexible	A
Main Body Width	Max. allowed by Subsection 3 of this building type	

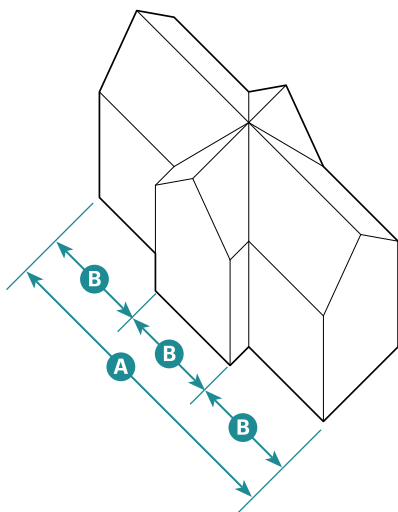
**Twin Gable**



This massing type divides the facade into three parts, with the middle part set back slightly to create a shallow open space. The roof is sloped and may be either hipped or gabled.

Number of Bays	3-4 bays	A
Main Body Width	Max. allowed by Subsection 3 of this building type	

**Center Gable (1/3 + 1/3 + 1/3)**



This massing type divides the facade into three equal parts, with the middle third projecting. The roof is sloped and may be either hipped or gabled.

Number of Bays	3-6 bays	A
Main Body Width	Max. allowed by Subsection 3 of this building type	
Massing Proportions	1/3 each	B

*This page intentionally left blank*



**22.06.110 Neighborhood Courtyard**



*Example of Neighborhood Courtyard*



*Example of Neighborhood Courtyard*



*Example of Neighborhood Courtyard*

**1. Description**

A detached, House-Scale Building that consists of up to 16 multiple attached and/or stacked units, accessed from a shared courtyard. The shared court is common open space and takes the place of a rear setback. The type is typically integrated as a small portion of lower-intensity neighborhoods or more consistently into moderate-intensity neighborhoods.

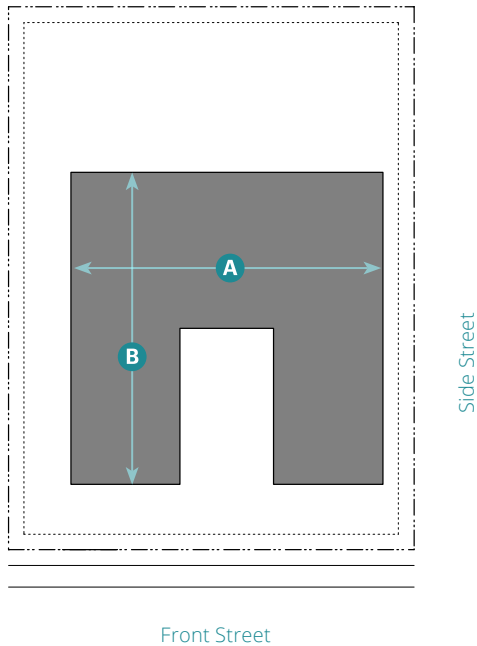
Synonym: Courtyard Apartment

**2. Number of Units**

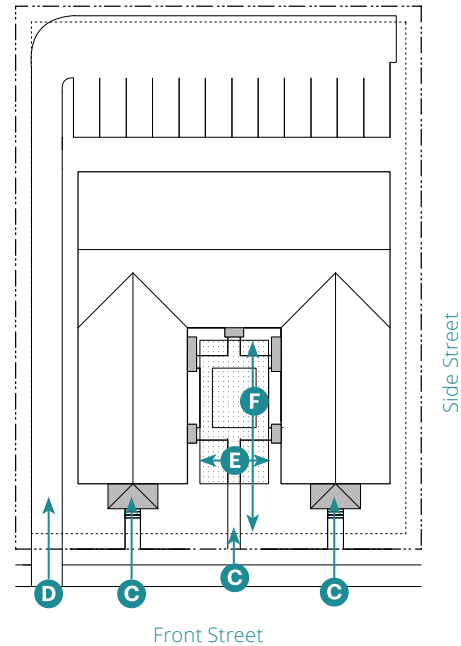
	<b>T4SN.S</b>	<b>T4SMS.S</b>
Units per Building	12 max.	16 max.
Buildings per Design Site	1 max.	

*General Note: Photos on this page are illustrative, not regulatory.*

Alley access required if alley exists



Alley access required if alley exists



**Key**

- - - ROW/ Design Site Line
- ..... Building Setback Line
- Building

**3. Building Size and Massing**

**Height**

Stories 2.5 max.

**Main Body<sup>1</sup>**

Width 100' max. **A**

Depth 100' max. **B**

**Wing(s)**

Not Allowed

Facades shall be designed in compliance with Chapter 8 (Specific to Architectural Design).

<sup>1</sup>In compliance with Subsection 5 of the zone

**Key**

- - - ROW/ Design Site Line
- ..... Building Setback Line
- Frontage
- ▨ Common Open Space

**4. Pedestrian Access**

Main Entrance Location<sup>2</sup> Courtyard or Street **C**

<sup>2</sup>The main entry of ground floor units shall be directly off of a courtyard or street, whichever is closer.

**5. Vehicle Access and Parking**

Driveway and parking location shall comply with standards in Subsection 7 of the zone. **D**

Parking may be covered, uncovered, or in a garage.

**6. Open Space**

Common Open Space	L-shaped	U-shaped	
Width	20' min.	25' min.	<b>E</b>
Depth	30' min.	60' min.	<b>F</b>

Courtyard(s) shall be accessible from the front street.

Multiple courtyards are required to be connected via a Passage through or between buildings.

Building shall define at least three walls of the courtyard.

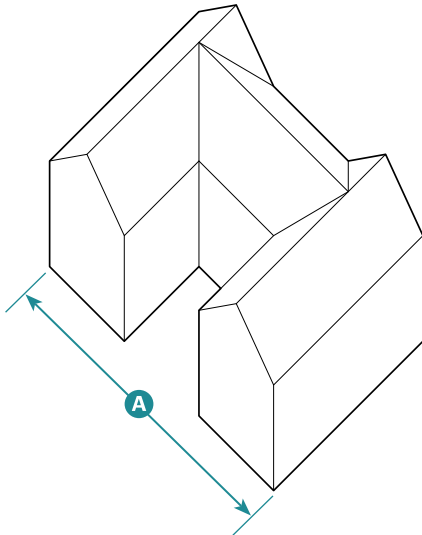
Up to 1/3 of the shared court(s) may be used for stormwater management if designed as a rain garden or bioswale.

Front of courtyard not defined by building shall be defined by 2'-6" to 5' tall wall with entry gate/door.

**7. Main Body Massing Composition**

Select from the allowed massing proportions and apply the standards to the main body width in compliance with Chapter 8 (Specific to Architectural Design) and the following standards.

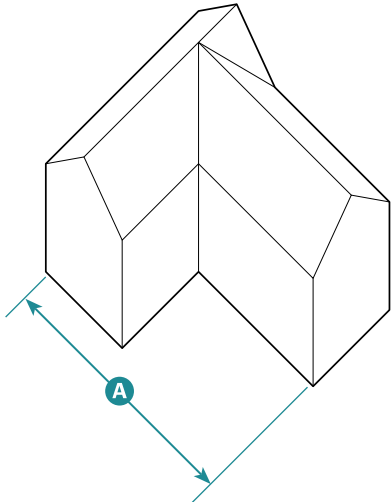
**Gabled Courtyard**



This massing type divides the facade into three parts, with the middle part set back substantially to create a deep open space. The roof is sloped and may be either hipped or gabled.

Number of Bays	6-9 bays	A
Main Body Width	Max. allowed by Subsection 3 of this building type	

**Gabled L Courtyard**



This massing type divides the facade into two parts, with one part set back substantially to create a deep open space. The roof is sloped and may be either hipped or gabled.

Number of Bays	4-6 bays	A
Main Body Width	Max. allowed by Subsection 3 of this building type	

*This page intentionally left blank*



**22.06.120 Pocket Neighborhood**



Source: Starr Hill Vision Plan

Example of Pocket Neighborhood



Source: Ross Chapin

Example of Pocket Neighborhood



Source: Ross Chapin

Example of Pocket Neighborhood

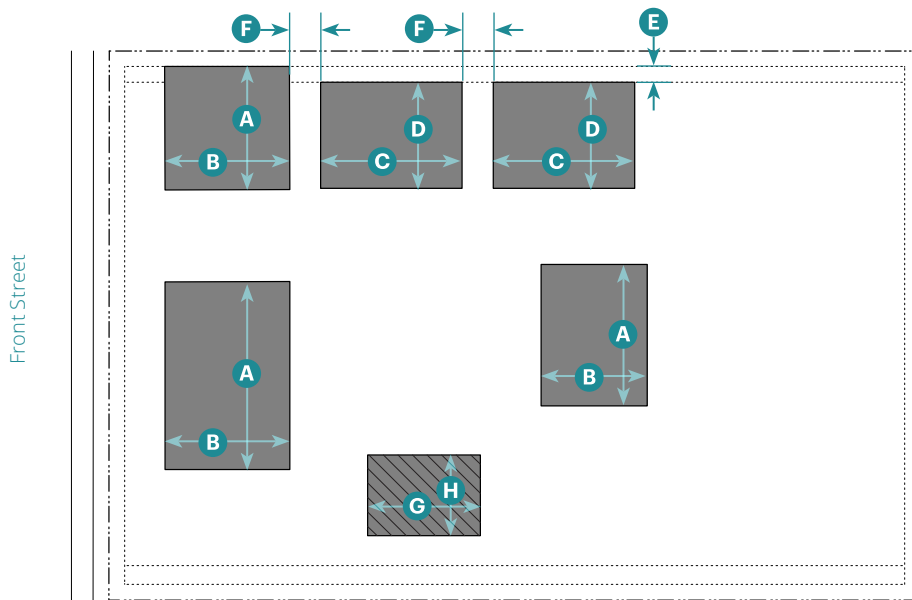
**1. Description**

A group of 5 to 10 detached, House-Scale Buildings each containing one to four units, arranged to define a shared open space. The shared open space is common open space and takes the place of a private rear setback, trees become an important community-enhancing element. The type is scaled to fit within low-to-moderate intensity neighborhoods.

**2. Number of Units**

	T3SN	T4SN.S
Units per Building	4 max.	5 max.
Buildings per Design Site	5 max.	

General Note: Photos on this page are illustrative, not regulatory.



**Key**

- - - - ROW/ Design Site Line
- ..... Building Setback Line
- Building
- ▨ Community Building

**3. Building Size and Massing**

**Main Body<sup>1</sup>**

Stories	2.5 max.	
Buildings along Front and Side Street		
Width	60' max.	<b>A</b>
Depth	40' max.	<b>B</b>
Buildings along Side and Rear		
Width	36' max.	<b>C</b>
Depth	48' max.	<b>D</b>
Side Setback in Addition to Zone Setback	5' min.	<b>E</b>
Building Separation <sup>2</sup>		
Between 1-story Buildings	10' min.	<b>F</b>
Between Buildings > 1-story	15' min.	

**3. Building Size and Massing (Continued)**

**Community Building<sup>1,3</sup>**

Stories	2.5 max.
Width	40' max. <b>G</b>
Depth	30' max. <b>H</b>

**Wing(s)**

Not Allowed

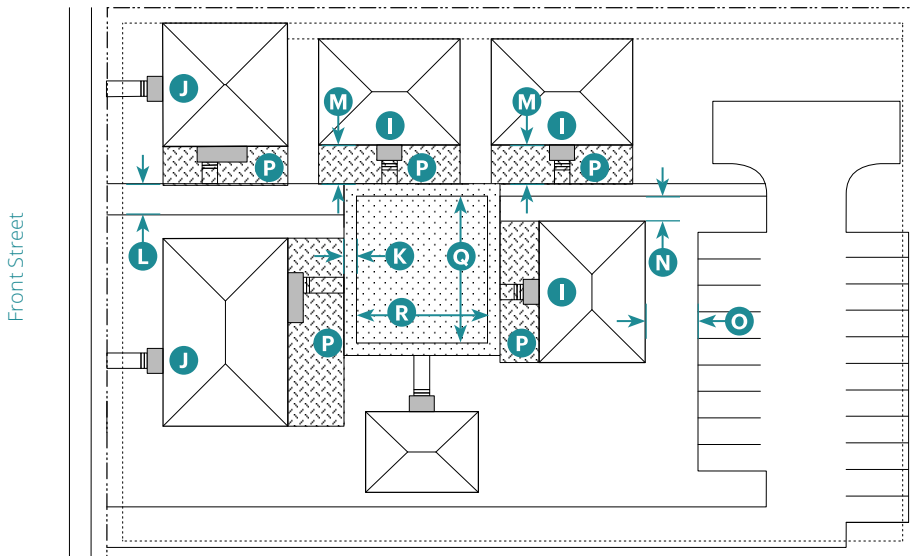
Facades shall be designed in compliance with Chapter 8 (Specific to Architectural Design).

No single-unit buildings allowed along the front or side street

<sup>1</sup> In compliance with Subsection 5 of the zone

<sup>2</sup> Including community building

<sup>3</sup> Shall front on common open space and is not allowed along front or side street



**Key**

- - - - ROW/ Design Site Line       Frontage
- ..... Building Setback Line

**4. Pedestrian Access**

<b>Main Entrance Location</b>		
Buildings with 1 Unit <sup>4</sup>	At Common Open Space	<b>I</b>
Buildings with 2 or more Units	At Front or Side Street	<b>J</b>
<b>Pedestrian Path Width</b>		
Along Buildings and Open Space	5' min.	<b>K</b>
At Front or Side Street Connection	10' min.	<b>L</b>
<b>Pedestrian Path Setbacks</b>		
From Building Entrance	12' min.	<b>M</b>
From Side of Building	8' min.	<b>N</b>

<sup>4</sup> Max. 40' from edge of common open space

**5. Vehicle Access and Parking**

Offset from Buildings	5' min.	<b>O</b>
-----------------------	---------	----------

Driveway and parking location shall comply with standards in Subsection 7 of the zone.

Parking not allowed along private or common open space.

Parking may be covered, uncovered, or in a garage.

Turnaround access required in compliance with Fire Department standards.

**Key**

- Private Open Space
- Common Open Space

**6. Open Space**

<b>Private Open Space per Building</b>		
Required for full length of building at all facades adjacent or abutting a pedestrian path or common open space <b>P</b>		
<b>Common Open Space<sup>5</sup></b>		<b>5 Bldgs.<sup>6</sup></b>
Width	30' min.	<b>Q</b>
Depth	40' min.	<b>R</b>

**7. Miscellaneous**

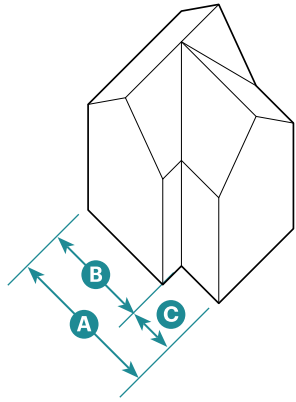
<b>Fencing</b>	
Fencing only allowed around or between individual buildings and shall not exceed 36" in height.	
Visibility shall be maintained through the fencing.	
<sup>5</sup> Shall provide access from front or side street	
<sup>6</sup> Not including community building	



**7. Main Body Massing Composition**

Select from the allowed massing proportions and apply the standards to the main body width for each building in compliance with Chapter 8 (Specific to Architectural Design).

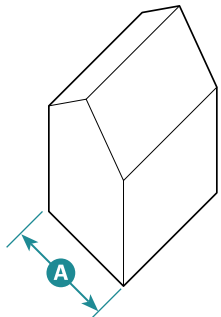
**1-2 Units per Building**



**Gable L (2/3 + 1/3)**

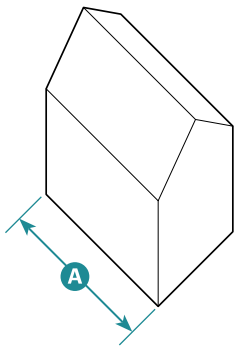
Number of Bays	3 bays
Main Body Width	Max. allowed by Subsection 3 of this building type

**1-4 Units per Building**



**Front Gable**

Number of Bays	2-3 bays
Main Body Width	Max. allowed by Subsection 3 of this building type

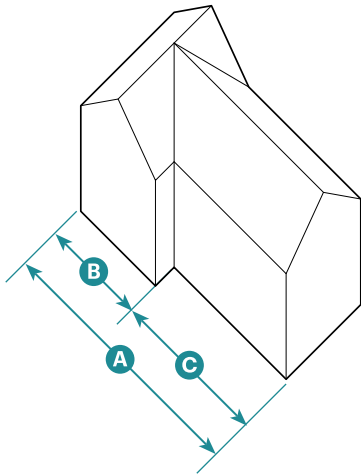


**Side Gable**

Number of Bays	3-5 bays
Main Body Width	Max. allowed by Subsection 3 of this building type

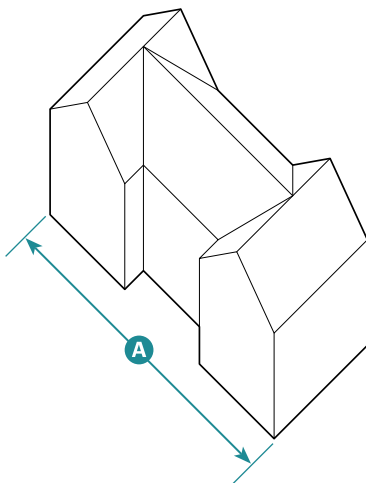
**7. Main Body Massing Composition (Continued)**

**2-4 Units per Building**



**Gable L (2/5 + 3/5)**

Number of Bays	3-6 bays
Main Body Width	Max. allowed by Subsection 3 of this building type



**Twin Gable**

Number of Bays	3-6 bays
Main Body Width	Max. allowed by Subsection 3 of this building type

22.06.130 Multiplex



Example of Multiplex



Example of Multiplex



Example of Multiplex including bonus height

**1. Description**

A medium-to-large-sized, detached, House-Scale Building that consists of 5 to 18 side-by-side and/or stacked units, typically with one shared entry. The type is scaled to fit within moderate-intensity neighborhoods.

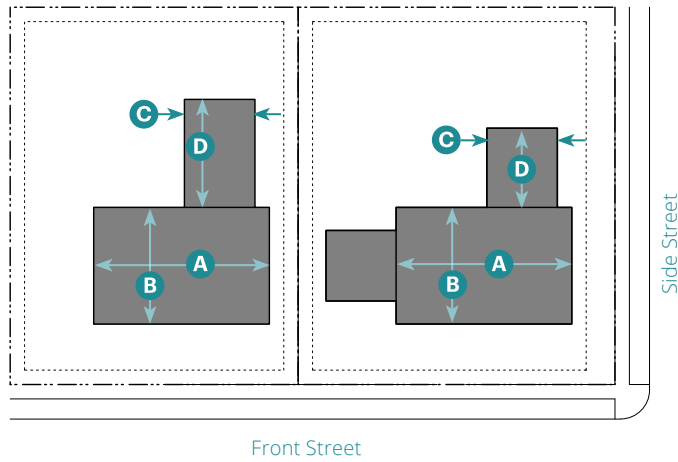
Synonym: Mansion Apartment

**2. Number of Units**

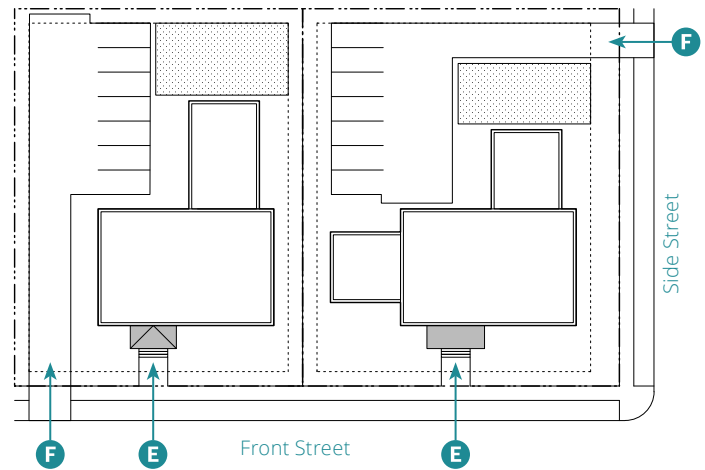
Units per Building	12 max.
Buildings per Design Site	1 max.

General Note: Photos on this page are illustrative, not regulatory.

Alley access required if alley exists



Alley access required if alley exists



**Key**

- - - ROW/ Design Site Line
- ..... Building Setback Line
- Building

**3. Building Size and Massing**

**Height**

Stories 2.5 max.

**Main Body<sup>1</sup>**

Width 60' max. **(A)**

Depth 60' max. **(B)**

**Wing(s)<sup>1,2</sup>**

Width 24' max. **(C)**

Depth 40' max. **(D)**

Separation between Wings 15' min.

Offset from Main Body 5' min.

Facades shall be designed in compliance with Chapter 8 (Specific to Architectural Design).

<sup>1</sup> In compliance with Subsection 5 of the zone

<sup>2</sup> Height is limited to 1 story less than main body and 10' less to highest eave/parapet.

**Key**

- - - ROW/ Design Site Line
- ..... Building Setback Line
- Frontage

**4. Pedestrian Access**

Main Entrance Location Front Street **(E)**

Units located in the main body shall be accessed by a common entry along the front street.

On corner design sites, units in a wing may enter from the side street.

**5. Vehicle Access and Parking**

Driveway and parking location shall comply with standards in Subsection 7 of the zone. **(F)**

Parking may be covered, uncovered, or in a garage.

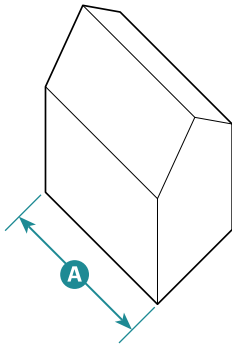
**6. Open Space**

Common or private open space is not required.

**7. Main Body Massing Composition**

Select from the allowed massing proportions and apply the standards to the main body width in compliance with Chapter 8 (Specific to Architectural Design) and the following standards.

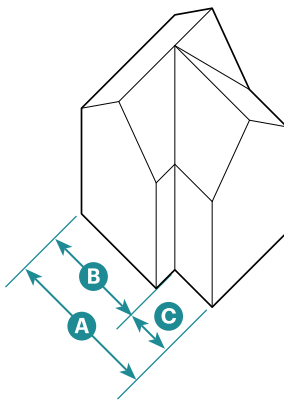
**Side Gable**



This massing type is a simple rectilinear form that is longer than it is deep. The roof is sloped and may be either hipped or gabled.

Number of Bays	Flexible	<b>A</b>
Main Body Width	Max. allowed by Subsection 3 of this building type	

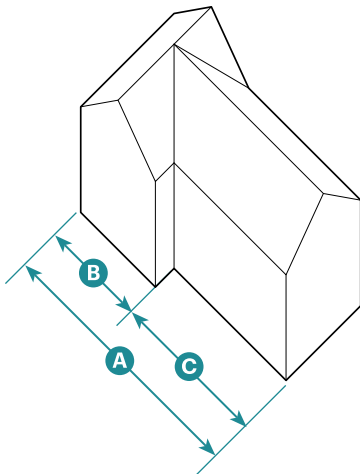
**Gable L (2/3 + 1/3)**



This massing type divides the facade into three equal parts, 1 part projecting and 2/3 as a wing. The roof is sloped with a gable at the projecting 1/3.

Number of Bays	3-6 bays	<b>A</b>
Main Body Width	Max. allowed by Subsection 3 of this building type	
Massing Proportions	2/3	<b>B</b>
	1/3	<b>C</b>

**Gable L (2/5 + 3/5)**

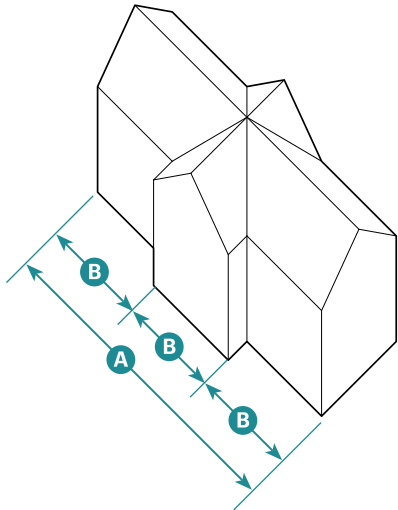


This massing type divides the facade into five equal parts, with two parts projecting and three parts set back to create a shallow forecourt. The roof is sloped with gables at the projecting two parts.

Number of Bays	5 bays	<b>A</b>
Main Body Width	Max. allowed by Subsection 3 of this building type	
Massing Proportions	2/5	<b>B</b>
	3/5	<b>C</b>

**7. Main Body Massing Composition (Continued)**

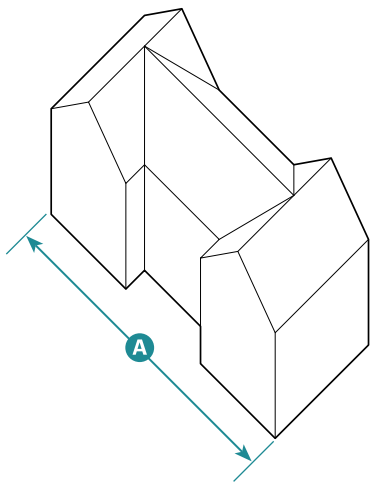
**Center Gable (1/3 + 1/3 + 1/3)**



This massing type divides the facade into three equal parts, with the middle third projecting. The roof is sloped and may be either hipped or gabled.

Number of Bays	3-6 bays	A
Main Body Width	Max. allowed by Subsection 3 of this building type	
Massing Proportions	1/3 each	B

**Twin Gable**



This massing type divides the facade into three parts, with the middle part set back slightly to create a shallow open space. The roof is sloped and may be either hipped or gabled.

Number of Bays	3-6 bays	A
Main Body Width	Max. allowed by Subsection 3 of this building type	

*This page intentionally left blank*



**22.06.140 Main Street Building**



Example of Main Street Building



Example of Main Street Building



Example of Main Street Building

**1. Description**

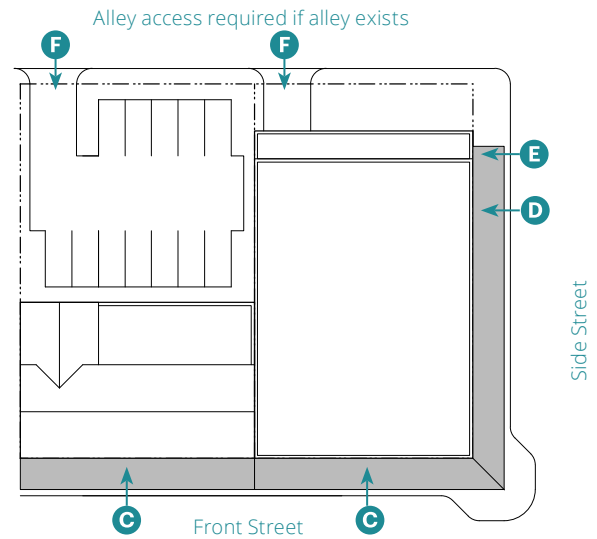
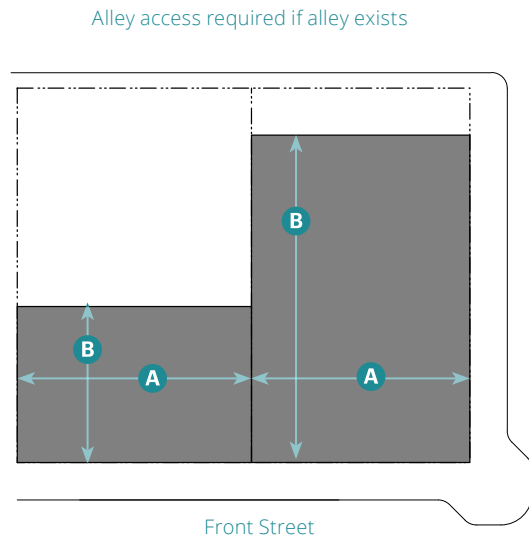
A small-to-large-sized, Block-Scale Building, typically attached, but may be detached. The type is intended to provide a vertical mix of uses with ground-floor retail, office, or service uses and upper-floor service or residential uses. The type makes up the primary component of neighborhood and downtown main streets, therefore being a key component to providing walkability.

**2. Number of Units**

Units per Building	Unrestricted <sup>1</sup>
Buildings per Design Site	1 max.

<sup>1</sup> Number of units restricted by International Building Code (IBC) and Uniform Fire Code (UFC) standards.

*General Note: Photos on this page are illustrative, not regulatory.*



**Key**

- - - - ROW/ Design Site Line
- ..... Building Setback Line
- Building

**3. Building Size and Massing**

**Height**

Stories 2.5 max.

**Main Body<sup>2</sup>**

Width 100 max. **(A)**

Depth 90 max. **(B)**

**Wing(s)**

Not Allowed

Facades shall be designed in compliance with Chapter 8 (Specific to Architectural Design).

<sup>2</sup> In compliance with Subsection 5 of the zone

**Key**

- - - - ROW/ Design Site Line
- ..... Building Setback Line
- Frontage
- Outline of Building above

**4. Pedestrian Access**

Distance between Entries to Ground Floor Shops 50' max.

Upper floor units shall be accessed by a common entry along the front street. **(C)**

Ground floor shops shall have individual entries along the adjacent street. **(D)**

Ground floor units allowed along side street at least 60' from front of design site.

On corner design sites, units in a wing or accessory structure may enter from the side street. **(E)**

**5. Vehicle Access and Parking**

Driveway and parking location shall comply with standards in Subsection 7 of the zone. **(F)**

Parking may be covered, uncovered, or in a garage.

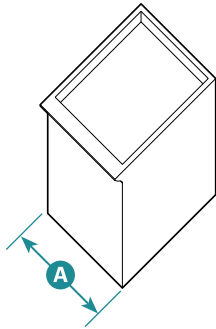
**6. Open Space**

Common or private open space is not required.

**7. Main Body Massing Composition**

Select from the allowed massing proportions and apply the standards to the main body width in compliance with Chapter 8 (Specific to Architectural Design) and the following standards.

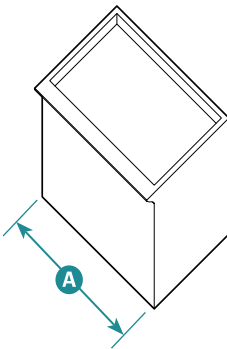
**Flat Box**



This massing type is a simple rectilinear form that is deeper than it is long. The roof is sloped and may be either hipped or gabled.

Number of Bays	Flexible	A
Main Body Width	Max. allowed by Subsection 3 of this building type	

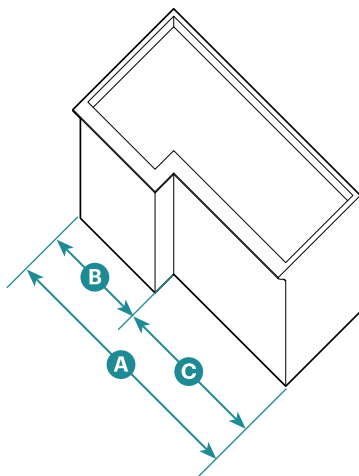
**Flat Bar**



This massing type is a simple rectilinear form that is longer than it is deep. The roof is flat.

Number of Bays	Flexible	A
Main Body Width	Max. allowed by Subsection 3 of this building type	

**Flat L (2/5 + 3/5)**

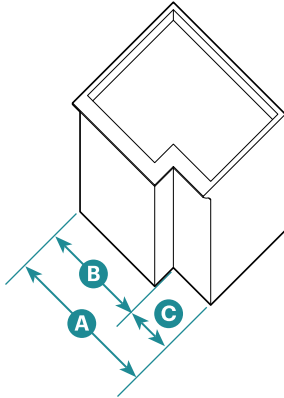


This massing type divides the facade into five equal parts, with two parts projecting and three parts set back to create a shallow forecourt. The roof is flat.

Number of Bays	Flexible	A
Main Body Width	Max. allowed by Subsection 3 of this building type	
Massing Proportions	2/5	B
	3/5	C

**7. Main Body Massing Composition (Continued)**

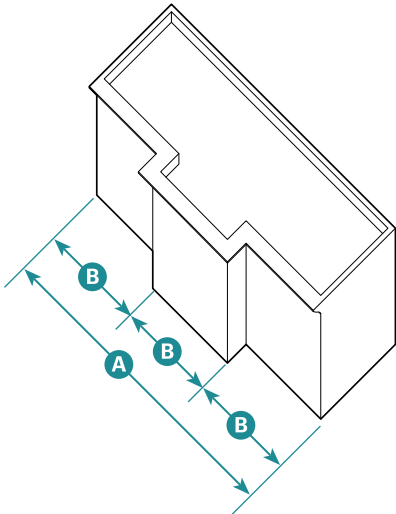
**Flat L (2/3 + 1/3)**



This massing type divides the facade into three equal parts, 1 part projecting with a gable roof and 2/3 as a wing. The roof is flat.

Number of Bays	Flexible	<b>A</b>
Main Body Width	Max. allowed by Subsection 3 of this building type	
Massing Proportions	2/3	<b>B</b>
	1/3	<b>C</b>

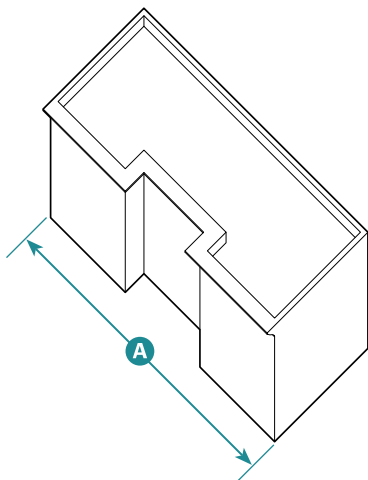
**Flat T (1/3 + 1/3 + 1/3)**



This massing type divides the facade into three equal parts, with the middle third projecting. The roof is flat.

Number of Bays	Flexible	<b>A</b>
Main Body Width	Max. allowed by Subsection 3 of this building type	
Massing Proportions	1/3 each	<b>B</b>

**Flat Forecourt**

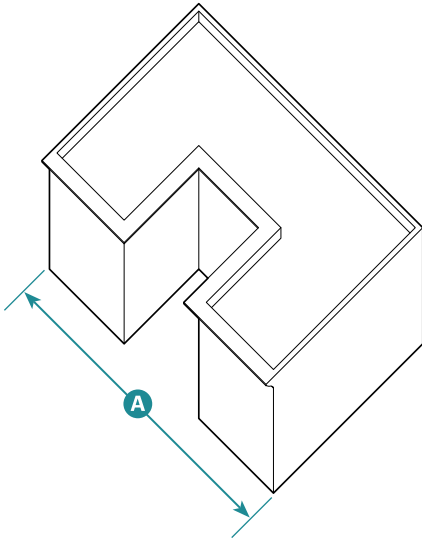


This massing type divides the facade into three parts, with the middle part set back slightly to create a shallow open space. The roof is flat.

Number of Bays	Flexible	<b>A</b>
Main Body Width	Max. allowed by Subsection 3 of this building type	

**7. Main Body Massing Composition (Continued)**

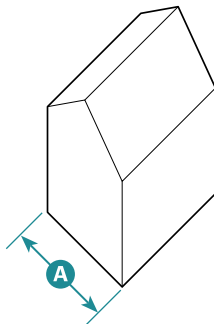
**Flat Courtyard**



This massing type divides the facade into three parts, with the middle part set back substantially to create a deep open space. The roof is flat.

Number of Bays	Flexible	A
Main Body Width	Max. allowed by Subsection 3 of this building type	

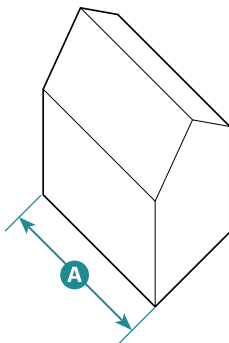
**Front Gable**



This massing type is a simple rectilinear form that is deeper than it is long. The roof is sloped and may be either hipped or gabled.

Number of Bays	Flexible	A
Main Body Width	Max. allowed by Subsection 3 of this building type	

**Side Gable**

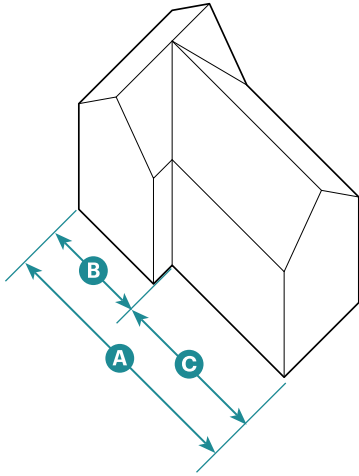


This massing type is a simple rectilinear form that is longer than it is deep. The roof is sloped and may be either hipped or gabled.

Number of Bays	Flexible	A
Main Body Width	Max. allowed by Subsection 3 of this building type	

**7. Main Body Massing Composition (Continued)**

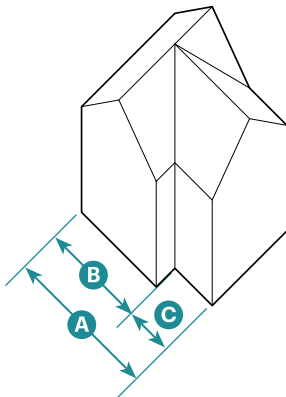
**Gable L (2/5 + 3/5)**



This massing type divides the facade into five equal parts, with two parts projecting and three parts set back to create a shallow forecourt. The roof is sloped with gables at the projecting two parts.

Number of Bays	Flexible	<b>A</b>
Main Body Width	Max. allowed by Subsection 3 of this building type	
Massing Proportions	2/5	<b>B</b>
	3/5	<b>C</b>

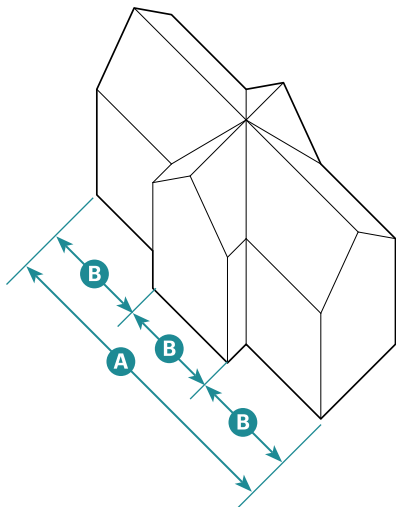
**Gable L (2/3 + 1/3)**



This massing type divides the facade into three equal parts, 1 part projecting and 2/3 as a wing. The roof is sloped with a gable at the projecting 1/3.

Number of Bays	Flexible	<b>A</b>
Main Body Width	Max. allowed by Subsection 3 of this building type	
Massing Proportions	2/3	<b>B</b>
	1/3	<b>C</b>

**Center Gable (1/3 + 1/3 + 1/3)**

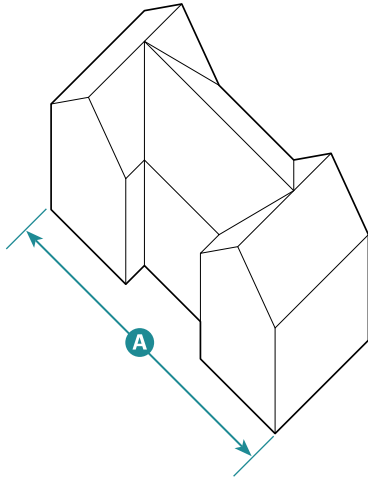


This massing type divides the facade into three equal parts, with the middle third projecting. The roof is sloped and may be either hipped or gabled.

Number of Bays	Flexible	<b>A</b>
Main Body Width	Max. allowed by Subsection 3 of this building type	
Massing Proportions	1/3 each	<b>B</b>

**7. Main Body Massing Composition (Continued)**

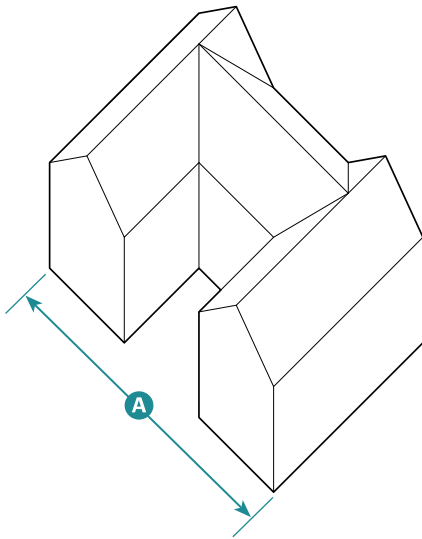
**Twin Gable**



This massing type divides the facade into three parts, with the middle part set back slightly to create a shallow open space. The roof is sloped and may be either hipped or gabled.

Number of Bays	Flexible	A
Main Body Width	Max. allowed by Subsection 3 of this building type	

**Gabled Courtyard**



This massing type divides the facade into three parts, with the middle part set back substantially to create a deep open space. The roof is sloped and may be either hipped or gabled.

Number of Bays	Flexible	A
Main Body Width	Max. allowed by Subsection 3 of this building type	



*This page intentionally left blank*

# Chapter 7: Specific to Private Frontage Types

---

## Sections:

22.07.010	Purpose
22.07.020	Private Frontage Types
22.07.030	Overview of Private Frontage Types
22.07.040	Porch Projecting
22.07.050	Porch Engaged
22.07.060	Dooryard
22.07.070	Stoop
22.07.080	Forecourt
22.07.090	Maker Shopfront
22.07.100	Shopfront
22.07.110	Terrace
22.07.120	Gallery

---

## 22.07.010 Purpose

This Chapter provides the standards for private frontages ("frontages"). Private frontages are the components of a building that provide the transition and interface between the public realm (street and sidewalk) and the private realm (setback or building).

---

## 22.07.020 Private Frontage Types

1. The names of the private frontage types indicate their particular configuration or function and are not intended to limit uses within the associated building. For example, a Porch may be used by non-residential uses including, but not limited to, a restaurant or office, as allowed by the zone.
2. Each building is required to include at least one private frontage type along the front street or adjacent civic space. Buildings with entries along a side street are required to include at least one private frontage type on those facades.
3. The ground floor, for a minimum depth as identified in Subsection 4 of the zone, is required to be habitable/occupiable space in compliance with this Chapter. Accessibility is provided through the allowed private frontage types for each zone.
4. Private frontage types not listed in Subsection 8 of the zone are not allowed in that zone.
5. Each building may have multiple private frontage types in compliance with the allowed types in Subsection 8 of the zone.
6. Each private frontage type shall be located in compliance with the facade zone per Subsection 5 of the zone.
7. Standards are stated for the front and side street facades of a design site.

8. In addition to the zone's standards, each private frontage is further refined through these standards to further calibrate the type for its context.
9. Certain types are only allowed in the open sub-zone (e.g., T4SN.S-O) or on a side street in the base zone (e.g., T4SMS.S) to implement the intended physical character.

## 22.07.030 Overview of Private Frontage Types

Table A (Private Frontage Types Overview) provides a summary of the allowed private frontage types in each zone. See referenced Section(s) for standards.

Private Frontage Type	Specific Standards	Zones		
		T3	T4	
		SN	SN.S	SMS.S
Porch Projecting	22.07.040	P	P	P
Porch Engaged	22.07.050	P	P	P
Dooryard	22.07.060	P	P	O
Stoop	22.07.070	X	P	O
Forecourt	22.07.080	X	X	P
Maker Shopfront	22.07.090	X	X	O
Shopfront	22.07.100	X	O	P
Terrace	22.07.110	X	X	P
Gallery	22.07.120	X	X	P

**Key**      P = Allowed      O = Allowed Only in Open Sub-Zone or Side Street      X = Not Allowed

*This page intentionally left blank*

22.07.040 Porch Projecting



Example of a Projecting Porch



Example of a Projecting Porch

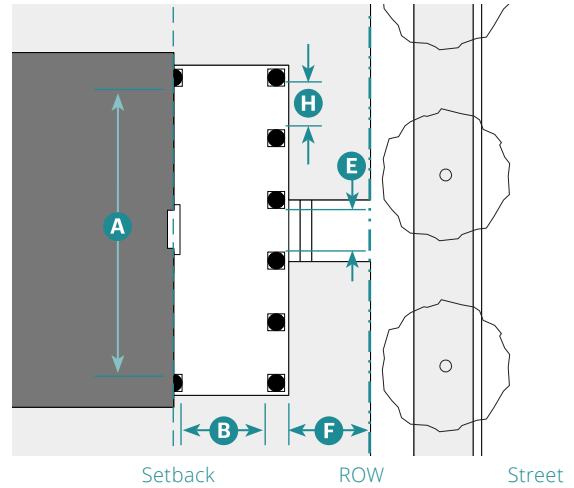
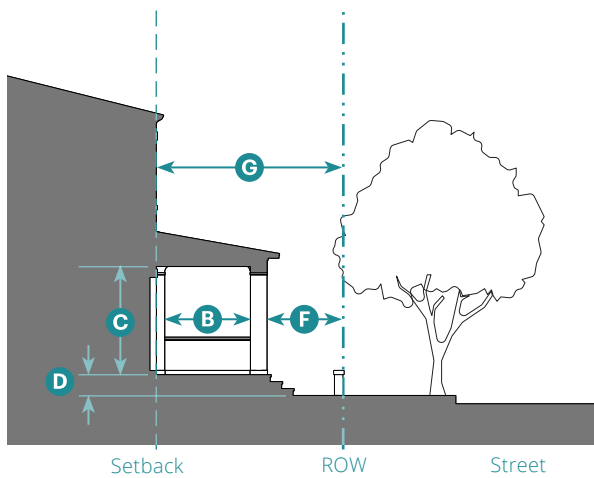


Example of a Projecting Porch

1. Description

The main facade of the building is set back from the front design site line with a covered structure encroaching into the front setback. The resulting setback area may be defined by a fence or hedge to spatially maintain the edge of the street. The Porch may be one or two stories, is open on three sides, with all habitable space located behind the building setback line.

General Note: Photos on this page are illustrative, not regulatory.



**Key**

--- ROW/ Design Site Line      - - - - - Setback Line

**2. Size**

Width, Clear	15' min. <sup>1</sup>	<b>A</b>
Depth, Clear	8' min.	<b>B</b>
Height, Clear	8' min.	<b>C</b>
Stories	2 stories max.	
Finish Level above Sidewalk	12" min. <sup>2</sup>	<b>D</b>
Pedestrian Access	3' wide min.	<b>E</b>
Distance between Porch and Sidewalk	6' min.	<b>F</b>
Depth	15' min.	<b>G</b>
Distance between Porch columns shall be in compliance with selected architectural style in Chapter 8 (Specific to Architectural Design).		<b>H</b>

<sup>1</sup> Reduce to 8' min. and maximum 1 story when applied to Cottage Court Building Type

<sup>2</sup> Common entries may be set at grade per local and federal accessibility standards.

**3. Miscellaneous**

Porch shall be open on three sides and have a roof. Clear glass may be installed between the porch columns if the minimum size of individual panes is in compliance with the standards in Chapter 8 (Specific to Architectural Design).

Ramps are required to be integrated along the side of the building to connect with the Projecting Porch.

The Porch shall be designed in compliance with the standards in Chapter 8 (Specific to Architectural Design) for the selected architectural style.



22.07.050 Porch Engaged



Example of an Engaged Porch



Example of a two-story Engaged Porch



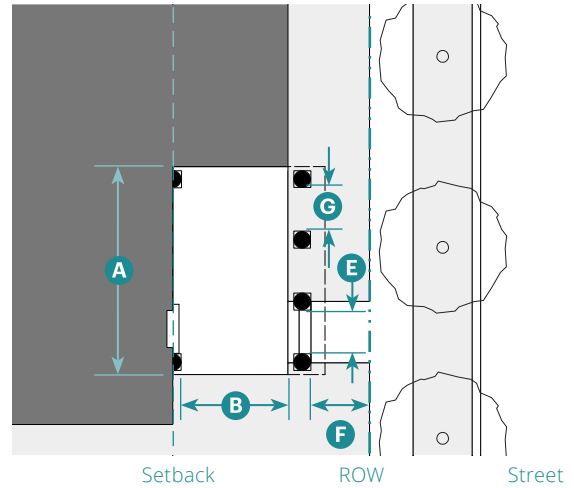
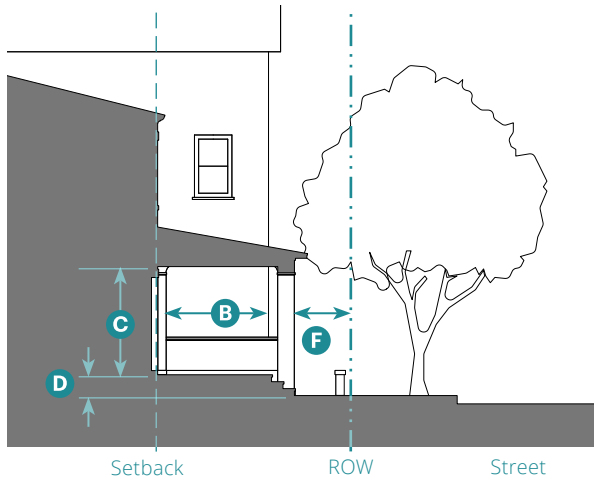
Example of an Engaged Porch

1. Description

A portion of the main facade of the building is set back from the front design site line to create an area for a covered structure that projects from the facade that is set back. The Porch may project into the front setback. The resulting setback may be defined by a fence or hedge to spatially maintain the edge of the street. The Porch may be one or two stories and has two adjacent sides that are engaged to the building, while the other two sides are open.

General Note: Photos on this page are illustrative, not regulatory.





**Key**

--- ROW/ Design Site Line      - - - - - Setback Line

2. Size		
Width, Clear	8' min.	<b>A</b>
Depth, Clear	8' min.	<b>B</b>
Height, Clear	8' min.	<b>C</b>
Stories	2 stories max.	
Finish Level above Sidewalk	12" min. <sup>1</sup>	<b>D</b>
Pedestrian Access	3' wide min.	<b>E</b>
Distance between Porch and Sidewalk	6' min.	<b>F</b>
Distance between Porch Columns		<b>G</b>
Distance between Porch columns shall be in compliance with selected architectural style in Chapter 8 (Specific to Architectural Design).		<b>H</b>

<sup>1</sup> Common entries may be set at grade per local and federal accessibility standards.

**3. Miscellaneous**

Up to 20% of the building facade and porch(es) may project into the front setback line for the zone.

Porch shall be open on two sides and have a roof. Clear glass may be installed between the porch columns if the minimum size of individual panes is in compliance with the standards in Chapter 8 (Specific to Architectural Design).

Ramps are required to be integrated along the side of the building to connect with the Engaged Porch.

The Porch shall be designed in compliance with the standards in Chapter 8 (Specific to Architectural Design) for the selected Architectural Style.

22.07.060 Dooryard



Example of a residential Dooryard



Example of a commercial Dooryard

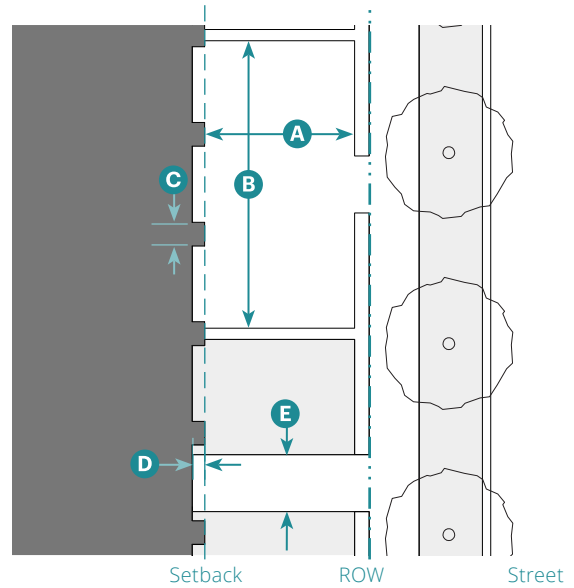
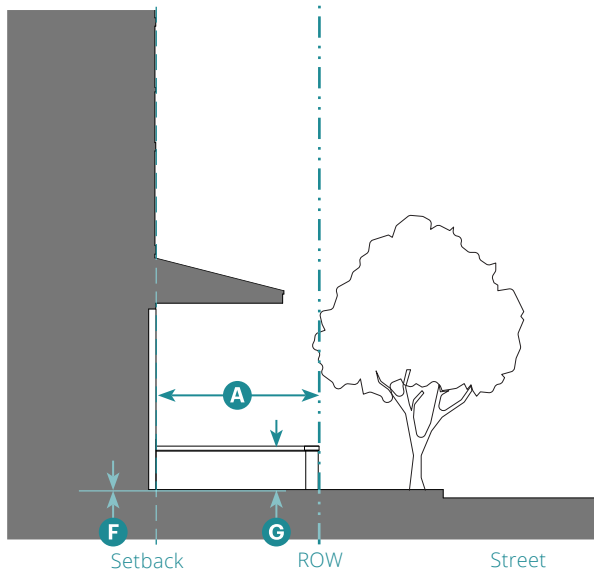


Example of a residential Dooryard

1. Description

The main facade of the building is set back from the front design site line, which is defined by a low wall or hedge, creating a small private area between the sidewalk and the facade. Each Dooryard is separated from adjacent Dooryards. The Dooryard may be raised or at grade.

General Note: Photos on this page are illustrative, not regulatory.



**Key**

- · - · - ROW/ Design Site Line      - - - - - Setback Line

2. Size		
Depth, Clear	6' min.	<b>A</b>
Length	15' min.	<b>B</b>
Distance between Glazing	4' max.	<b>C</b>
Depth of Recessed Entries	3' max.	<b>D</b>
Pedestrian Access	3' wide min.	<b>E</b>
Finish Level above Sidewalk	12" max. <sup>1</sup>	<b>F</b>
Height of Dooryard Fence/Wall above Finish Level	36" max.	<b>G</b>

<sup>1</sup>Common entries may be set at grade per local and federal accessibility standards.

**3. Miscellaneous**

For live/work, retail, service, and restaurant uses, the Shopfront Frontage Type (22.07.100) may be applied.

Each Dooryard shall provide access to only one ground floor entry.

Ramps are required to be integrated along the side of the building to connect with the Dooryard.

The Dooryard shall be designed in compliance with the standards in Chapter 8 (Specific to Architectural Design) for the selected architectural style.



22.07.070 Stoop



Example of a Stoop with paired entries



Example of a Stoop

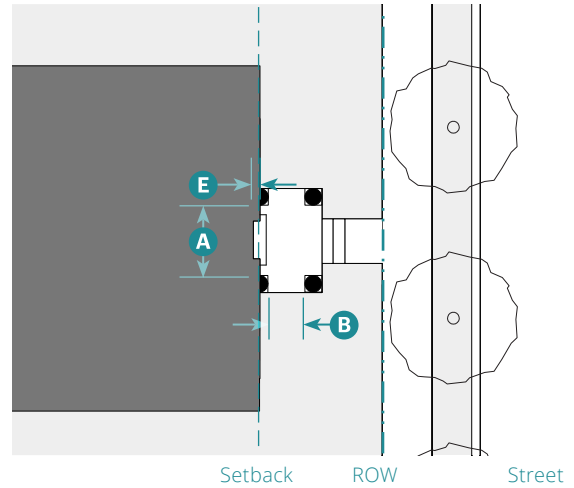
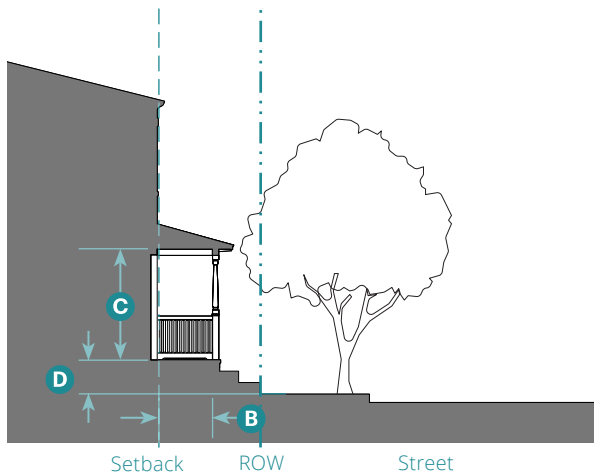


Example of a Stoop

1. Description

The main facade of the building is near the front design site line with steps to an elevated entry. The Stoop is elevated above the sidewalk to provide privacy along the sidewalk-facing rooms. Stairs or ramps from the Stoop may lead directly to the sidewalk or may be parallel to the sidewalk.

General Note: Photos on this page are illustrative, not regulatory.



**Key**

--- ROW/ Design Site Line      ..... Setback Line

2. Size		
Width, Clear	4' min.	<b>A</b>
Depth, Clear	3' min.	<b>B</b>
Height, Clear	8' min.	<b>C</b>
Stories	1 story max.	
Finish Level above Sidewalk	12" min.	<b>D</b>
Depth of Recessed Entries	8' max.	<b>E</b>

- ### 3. Miscellaneous
- Stairs may be perpendicular or parallel to the building facade.
  - Entry doors shall be covered or recessed to provide shelter from the elements.
  - Gates are not allowed.
  - All doors shall face the street.
  - Ramps are required to be integrated along the side of the building to connect with the Stoop.
  - The Stoop shall be designed in compliance with the standards in Chapter 8 (Specific to Architectural Design) for the selected architectural style.



## 22.07.080 Forecourt



*Example of a Forecourt with Shopfronts*



*Example of a Forecourt with outdoor dining*

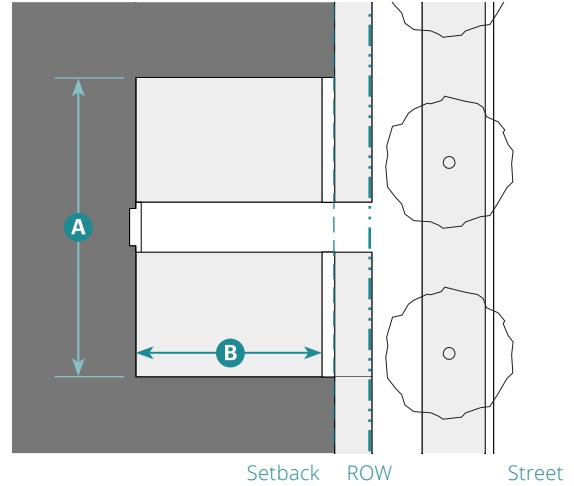
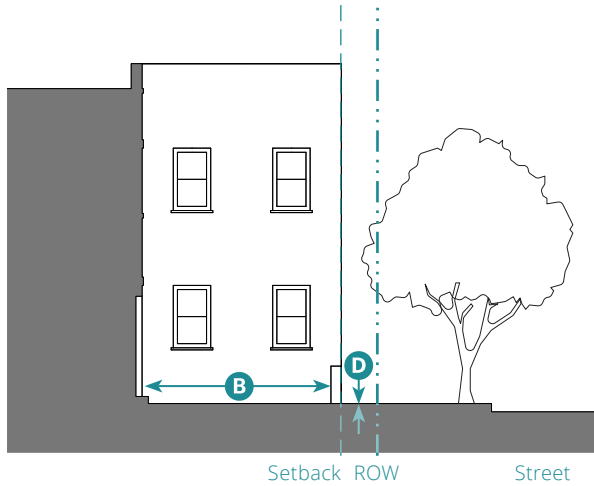


*Example of Forecourt*

### 1. Description

The main facade of the building is at or near the front design site line and a portion is set back, extending the public realm into the design site to create an entry court or shared garden space for housing, or an additional shopping or restaurant seating area within retail and service areas.

*General Note: Photos on this page are illustrative, not regulatory.*



**Key**

--- ROW/ Design Site Line      ..... Setback Line

**2. Size**

Width, Clear	15' min.	<b>A</b>
Depth, Clear	15' min.	<b>B</b>
Ratio, Height to Width	2:1 max.	<b>C</b>
Finish Level above Sidewalk	12" max.	<b>D</b>
Gallery frontages, awnings, balconies and porches may encroach into Forecourt on all sides.	Max 1/2 width of Forecourt	<b>E</b>

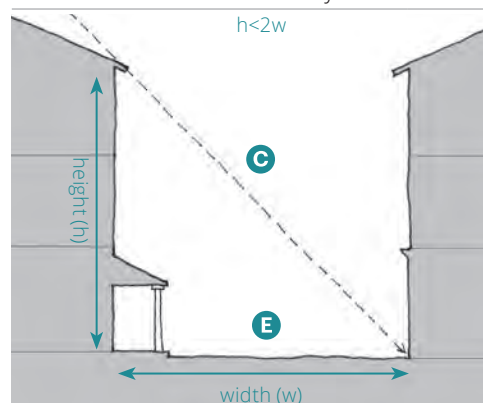
**3. Miscellaneous**

Forecourts may be utilized to group several entries at a common elevation in compliance with the zones' ground floor finish level standards.

The proportions and orientation of a Forecourt shall be in compliance with the diagram below for solar orientation and user comfort.

Ramps are required to be integrated along the side of the building to connect with the Forecourt.

The Forecourt shall be designed in compliance with the standards in Chapter 8 (Specific to Architectural Design) for the selected architectural style.





22.07.090 Maker Shopfront



Example of a Maker Shopfront



Example of a Maker Shopfront

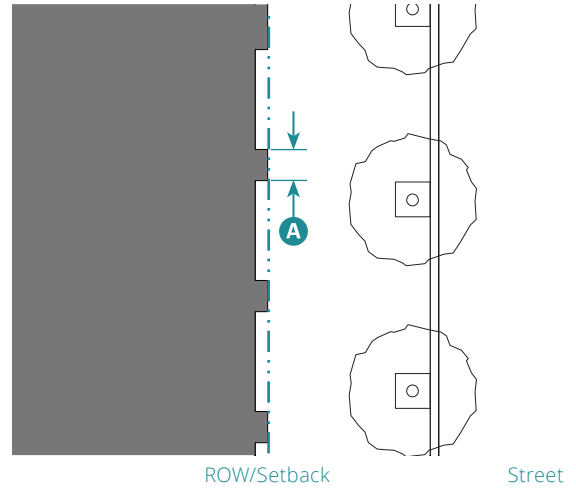
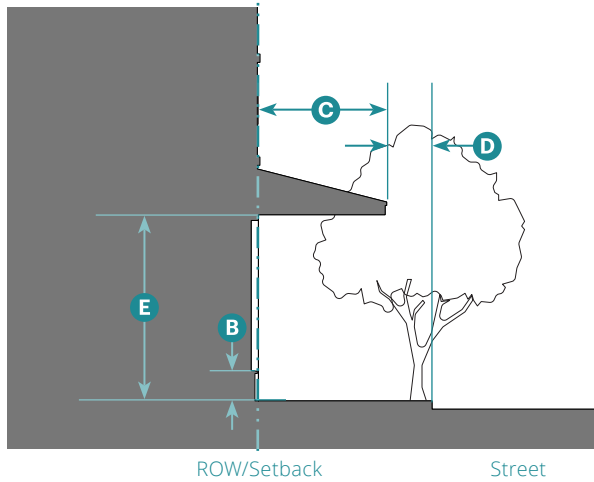


Example of a Maker Shopfront

1. Description

The main facade of the building is at or near the front design site line with an at-grade or elevated entrance from the sidewalk. The type is only allowed on side streets from the adjacent main street and is intended for industrial artisan businesses to show their activity to pedestrians, as well as for retail sales of products made on-site. The Maker Shopfront may include a decorative roll-down or sliding door, including glazing and an awning that overlaps the sidewalk.

General Note: Photos on this page are illustrative, not regulatory.



**Key**

- - - - ROW/ Design Site Line      - - - - Setback Line

**2. Size**

Distance between Glazing	10' max.	<b>A</b>
Ground Floor Glazing between Sidewalk and Finished Ceiling Height	30% min.	
Depth of Recessed Entries	No max.	
Shopfront Base (if used)	48" max.	<b>B</b>

**3. Awning**

Depth	5' min.	<b>C</b>
Setback from Curb	2' min.	<b>D</b>
Height, Clear	8' min.	<b>E</b>

**4. Miscellaneous**

Decorative accordion-style doors/windows or other operable windows that allow the space to open to the street are allowed in compliance with Chapter 8 (Specific to Architectural Design).

The Maker Shopfront shall be designed in compliance with the standards in Chapter 8 (Specific to Architectural Design) for the selected architectural style.



22.07.100 Shopfront



Example of Shopfronts



Example of a Shopfront

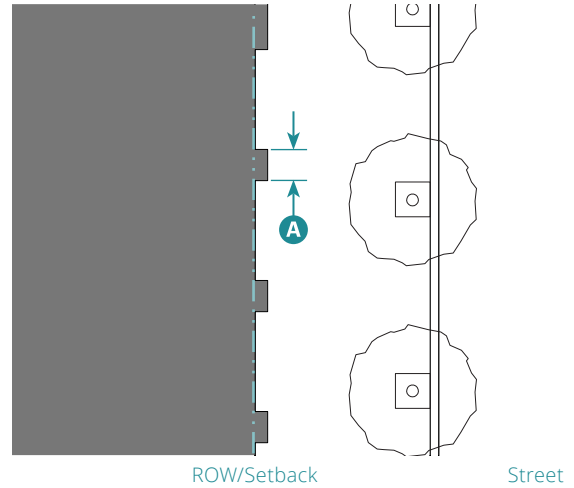
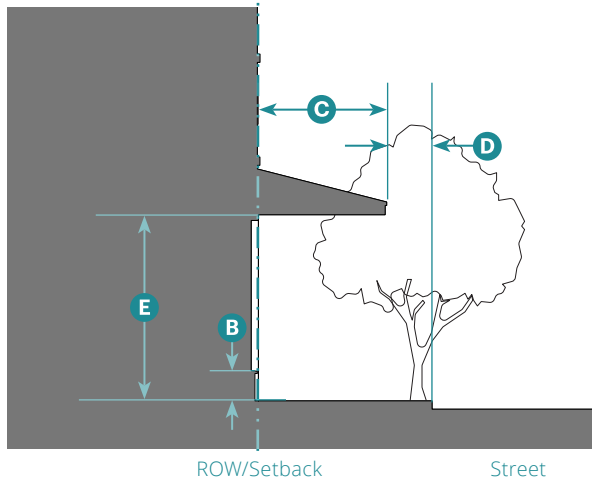


Example of a Shopfront

1. Description

The main facade of the building is at or near the front design site line with at-grade entrance from the sidewalk. The type is intended for service, retail, or restaurant use and includes substantial glazing between the Shopfront base and the ground floor ceiling. This type may include an awning that overlaps the sidewalk.

General Note: Photos on this page are illustrative, not regulatory.



**Key**

--- ROW/ Design Site Line      - - - - - Setback Line

**2. Size**

Distance between Glazing	2' max.	<b>A</b>
Ground Floor Glazing between Sidewalk and Finished Ceiling Height	75% min.	
Depth of Recessed Entries	5' max.	
Shopfront Base	6" min.; 24" max.	<b>B</b>

**3. Awning**

Depth	5' min.	<b>C</b>
Setback from Curb	2' min.	<b>D</b>
Height, Clear	8' min.	<b>E</b>

**4. Miscellaneous**

Decorative accordion-style doors/windows or other operable windows that allow the space to open to the street are allowed in compliance with Chapter 8 (Specific to Architectural Design).

Ramps are required to be integrated along the side of the building to connect with the Shopfront.

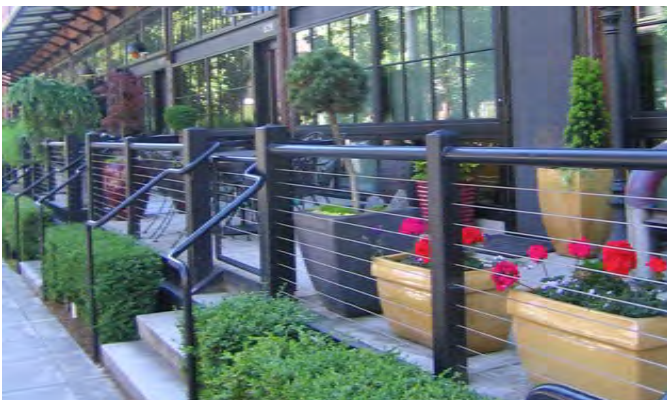
The Shopfront shall be designed in compliance with the standards in Chapter 8 (Specific to Architectural Design) for the selected architectural style.



22.07.110 Terrace



Example of a Terrace with low-wall seating



Example of a Terrace

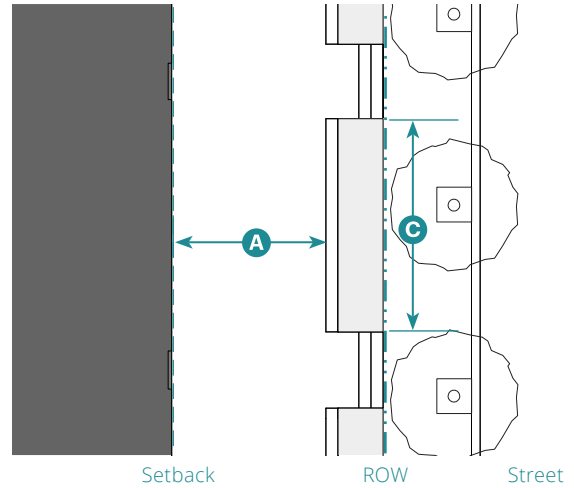
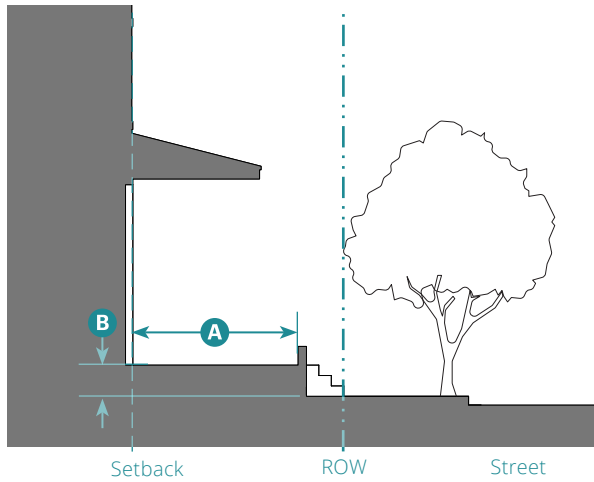


Example of a residential Terrace along a courtyard

1. Description

The main facade is at or near the front design site line with steps leading to an elevated area providing pedestrian circulation along the facade. The type is used for retail, service, office uses, or housing to provide outdoor areas along the sidewalk and/or to accommodate an existing or intended grade change.

General Note: Photos on this page are illustrative, not regulatory.



**Key**

--- ROW/ Design Site Line      - - - - - Setback Line

2. Size		
Depth of Terrace	8' min. residential; 12' min. non-residential	<b>A</b>
Finish Level above Sidewalk	36" max.	<b>B</b>
Distance between Stairs	25' max.	<b>C</b>

**3. Miscellaneous**

These standards are to be used with those for the Shopfront Frontage Type (22.07.100) where the zone requires the Shopfront Frontage Type.

Where the zone requires the Shopfront Frontage Type (22.07.100) and the ground floor is flush with the sidewalk, the Terrace shall be considered to be the sidewalk.

May be utilized to group several entries at a common elevation in compliance with the zones' ground floor finish level standards.

Ramps are required to be integrated along the side of the building to connect with the Terrace.

The Terrace shall be designed in compliance with the standards in Chapter 8 (Specific to Architectural Design) for the selected architectural style.



22.07.120 Gallery



Source: Google Street View

Example of a two-story Gallery with an uncovered second story.



Example of a Gallery providing covered outdoor dining



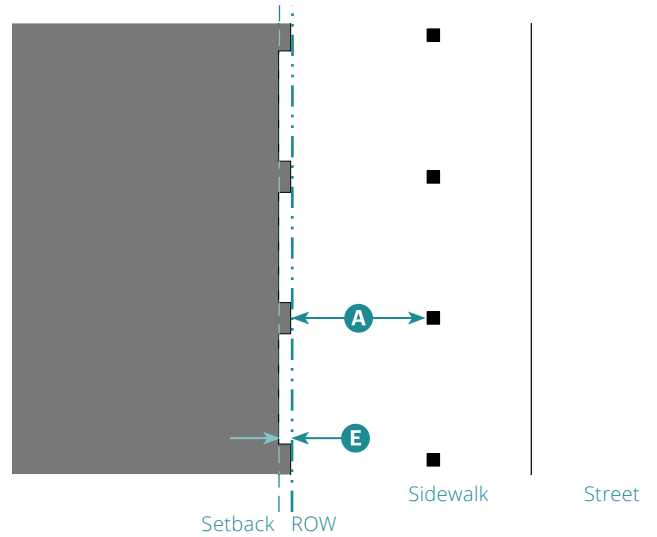
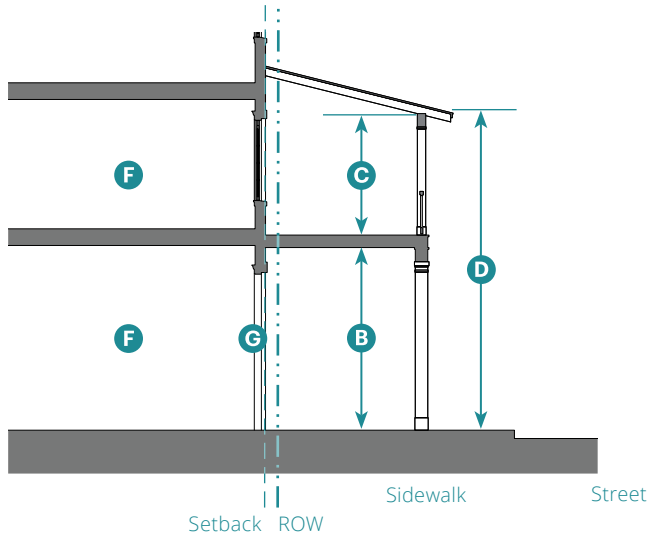
Example of a Gallery with shopfronts

1. Description

The main facade of the building is set back from the front design site line and an at-grade covered structure, articulated with colonnade or arches, overlaps the sidewalk. The type may be one or two stories. When used in nonresidential settings, the Shopfront Type is included; when used in residential settings, Stoops, Dooryards, and Forecourts may be included as allowed by the zone.

General Note: Photos on this page are illustrative, not regulatory.





**Key**

--- ROW/ Design Site Line      ..... Setback Line

2. Size		
Depth, Clear	8' min.	<b>A</b>
Ground Floor Height, Clear	12' min.	<b>B</b>
Upper Floor Height, Clear	9' min.	<b>C</b>
Height	2 stories max.	<b>D</b>
Gallery Setback from Public ROW	18" min. (clear)	<b>E</b>

**3. Miscellaneous**

- Habitable space **F**
- Galleries shall also follow the standards for the Shopfront Frontage Type (22.07.100). **G**
- Galleries shall have a consistent depth across the entire front and/or side street facade.
- Galleries are allowed to project over the sidewalk in the public ROW.
- The second story of the Gallery may be covered.
- Planting is not required. Lighting is required within the gallery in compliance with Subsection 22.05.030.3.
- Ramps are required to be integrated along the side of the building to connect with the Gallery, where applicable.
- The Gallery shall be designed in compliance with the standards in Chapter 8 (Specific to Architectural Design) for the selected architectural style.

*This page intentionally left blank*

# Chapter 8: Specific to Architectural Design

---

## Sections:

22.08.010	Purpose
22.08.020	Applicability
22.08.030	Architectural Design Standards
22.08.040	Overview of Architectural Styles
22.08.050	Contemporary
22.08.060	Craftsman
22.08.070	East Coast Cottage
22.08.080	Main Street Classical
22.08.090	Mediterranean

---

## 22.08.010 Purpose

This Chapter sets forth standards that supplement the zone standards to further refine the intended building form and physical character.

---

## 22.08.020 Applicability

Unless stated otherwise, all subsections within each architectural style ("style") identified in this Chapter apply to all facades of a building, including front facades, side street facades, side interior facades, and rear facades.

---

## 22.08.030 Architectural Design Standards

This Chapter contains architectural design standards for the five allowed styles. The standards for each style address a range of topics based on local architectural examples. The standards address the following aspects of individual building design: Roofs and roof pitch, eaves, cornices, walls, base of walls, dormers, openings and doors, storefronts, porches, and balconies.

1. Each building is required to be designed in compliance with one of the allowed architectural styles.
2. The architectural style standards are coordinated with the building types allowed by this FBC and the intended physical character of each zone.
3. Any facade greater than 75 feet in length along a street (public or private) or civic space shall include more than one architectural style, with a maximum 75 feet in length of any one style.

---

## 22.08.040 Overview of Architectural Styles

Table A (Architectural Styles Overview) provides an overview of the allowed architectural styles.

**Table 22.08.040.A: Architectural Styles Overview**

**Contemporary 22.08.050**



**Typical Characteristics**

Long, low-sloped roof forms with simple eaves with deep overhangs

Asymmetrical facade compositions with square and horizontal openings often made from ganged vertical windows

Mix of exterior materials to differentiate massing forms, with prevalent natural materials including wood siding

Horizontally proportioned balconies and terraces with minimalist vertical supports

**Applicable Standards**

- Wall
- Building Roof
- Rake
- Eave
- Parapet
- Windows
- Bay Windows
- Dormers
- Entry Doors
- Balconies
- Porches
- Storefronts
- Materials

**Craftsman 22.08.060**



**Typical Characteristics**

Low-pitched roofs with deep eaves and exposed rafter tails

Horizontally proportioned openings made from ganged vertical windows

Emphasis on natural materials including wood shingles

Asymmetrical composition with wall plane broken by projecting gable ends

**Applicable Standards**

- Wall
- Base
- Building Roof
- Rake
- Eave
- Parapet
- Windows
- Bay Windows
- Dormers
- Entry Doors
- Balconies
- Porches
- Storefronts
- Materials

**East Coast Cottage 22.08.070**



**Typical Characteristics**

Prominent gabled or gambrel roof forms

Shingle or horizontal lap siding as primary facade material

Vertically proportioned openings with surround

Painted trim, often white in color

Top story partially within roof with shed dormers

**Applicable Standards**

- Building Roof
- Rake
- Eave
- Windows
- Bay Windows
- Dormers
- Entry Doors
- Balconies
- Porches
- Storefronts
- Materials

**Table 22.08.040.A: Architectural Styles Overview (Continued)**

**Main Street Classical 22.08.080**



**Typical Characteristics**

Symmetrical facade composition with proportions that imply load-bearing masonry structure

Prominent cornice with classical detailing and parapet or pedimented roof forms

Regular pattern of vertically proportioned openings

Brick and stucco as primary facade materials

**Applicable Standards**

- Base
- Building Roof
- Parapet
- Windows
- Bay Windows
- Entry Doors
- Balconies
- Porches
- Storefronts
- Materials

**Mediterranean 22.08.090**



**Typical Characteristics**

Low-pitched gabled or hipped roofs clad in red tile with open eaves

Flat, rectilinear wall plane with vertically proportioned punched openings without trim

Stucco as primary facade material with stucco or wood attached elements

**Applicable Standards**

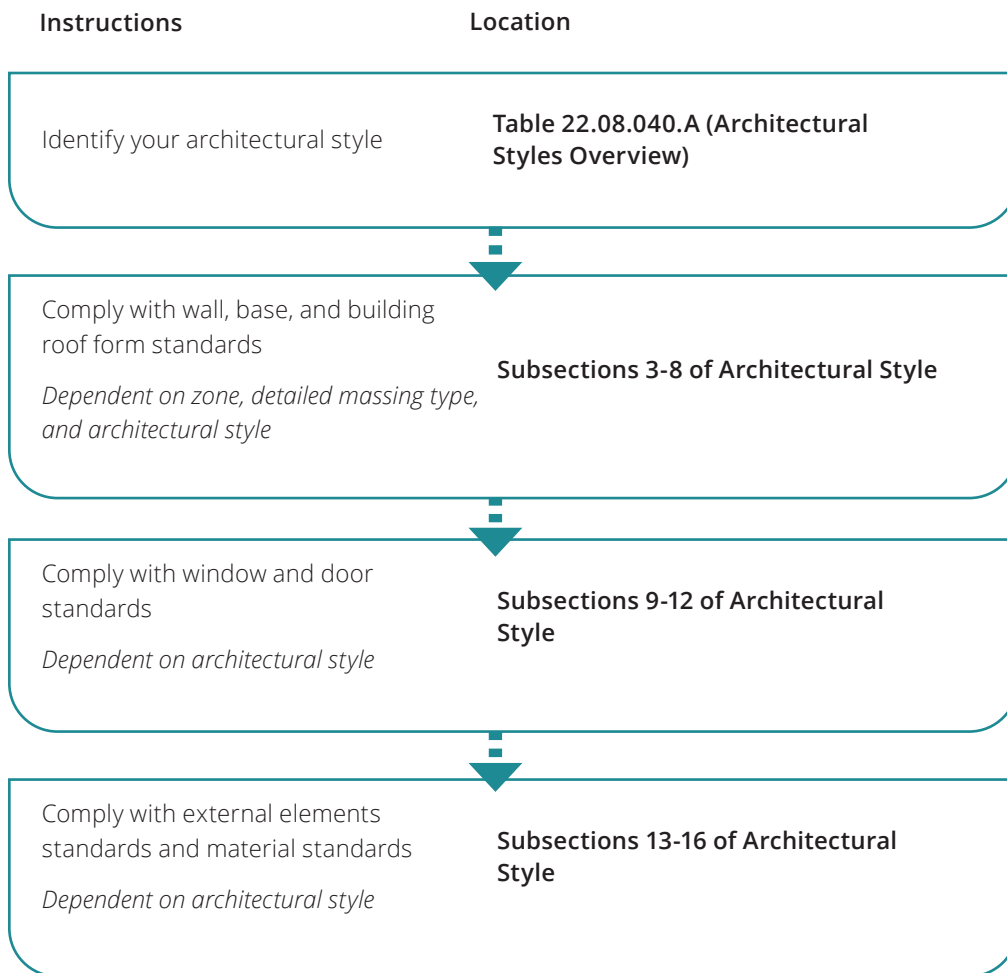
- Building Roof
- Eave
- Parapet
- Windows
- Bay Windows
- Dormers
- Entry Doors
- Balconies
- Porches
- Storefronts
- Materials

# Quick Code Guide: Specific to Architectural Design

The following graphic is intended as a summary guide. Please refer to the procedures for applications eligible for streamlined review consistent with State Law [Section 22.10.020 (Procedures)] for all necessary information.

**Before you begin**

Identify your zone, building type, and detailed massing type. If you have not done this yet, go back to the Table of Contents and follow the Quick Code Guide.





**22.08.050 Contemporary**



*General note: The images above and the descriptions in Subsections 1 and 2 below are intended to provide a brief overview of the architectural style and are descriptive, not regulatory.*

**1. Description of Style**

Contemporary style buildings have a streamlined aesthetic and minimal ornamentation. This style focuses on combining simple rectilinear massing forms with changes in material and color. The use of glass and cantilevered elements imbues buildings with a sense of lightness and simplicity. This style is prevalent throughout Marin County.

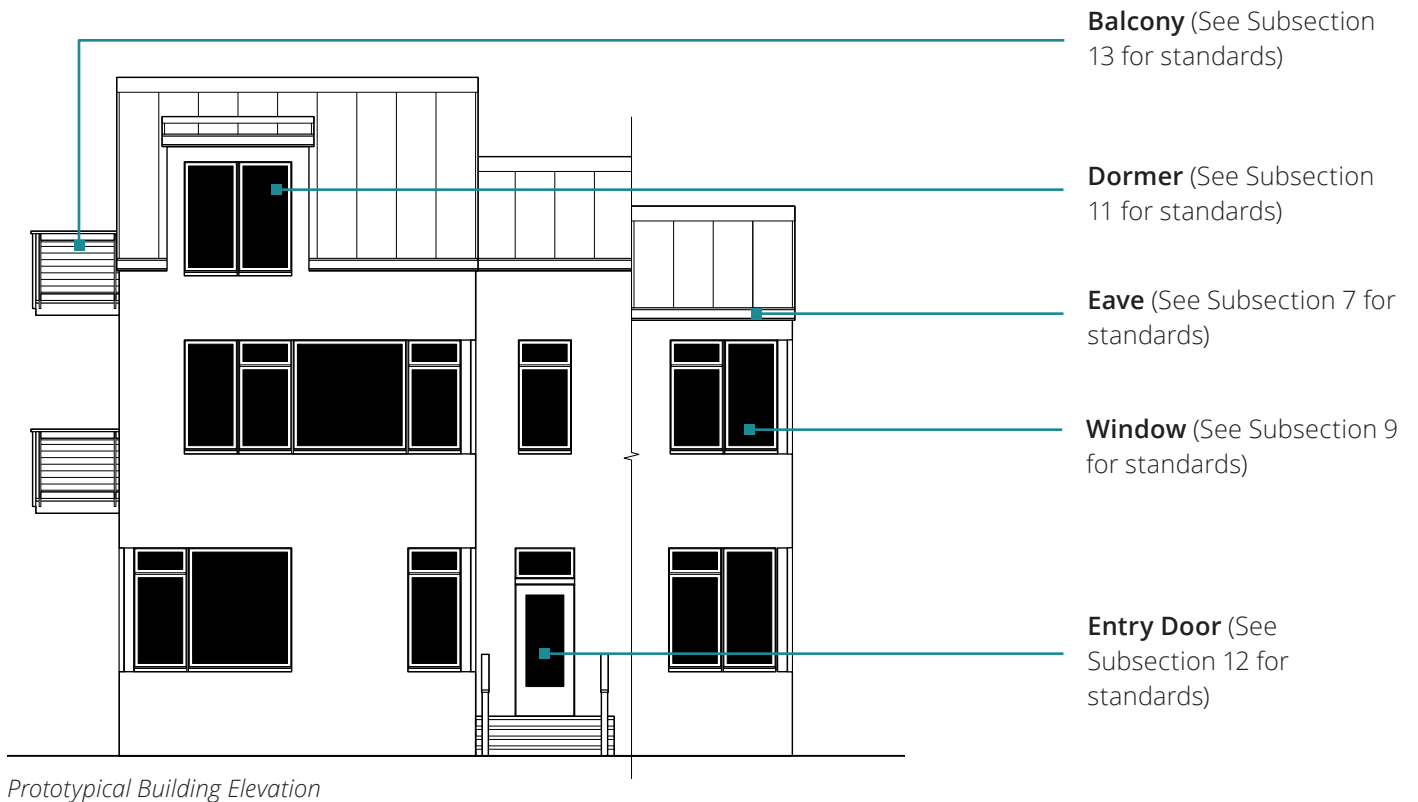
**2. Typical Characteristics**

- Long, low-sloped roof forms with simple eaves with deep overhangs
- Asymmetrical facade compositions with square and horizontal openings often made from ganged vertical windows
- Mix of exterior materials to differentiate massing forms, with prevalent natural materials including wood siding
- Horizontally proportioned balconies and terraces with minimalist vertical supports



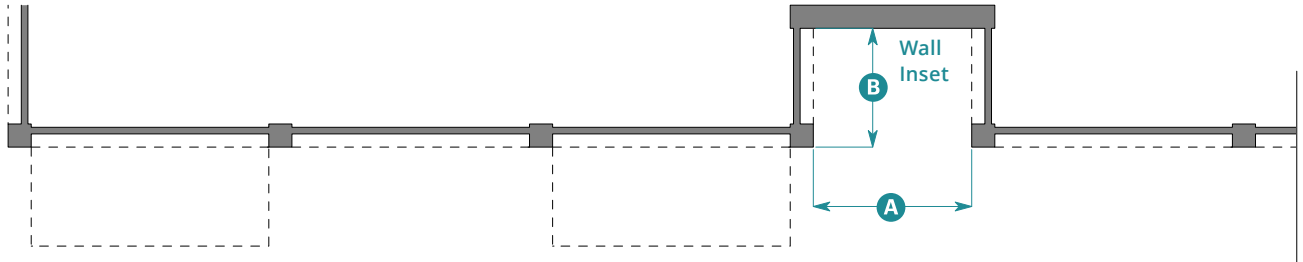
## Elements of Contemporary Style – Multifamily Prototype

Note: The image below is intended to provide a reference for architectural elements and is illustrative, not regulatory. It is not an exhaustive list of applicable standards.



# Elements of Contemporary Style – Mixed-Use Prototype

Note: The image below is intended to provide a reference for architectural elements and is illustrative, not regulatory. It is not an exhaustive list of applicable standards.



Prototypical Building Plan, Primary Facade



Prototypical Building Elevation

### 3. Wall

#### Wall Inset

A wall inset from the primary facade is required for buildings greater than 75' in width.

Wall inset shall be continuous for the full height of the building.

Roof and wall projections may encroach into wall inset.

### 3. Wall (Continued)

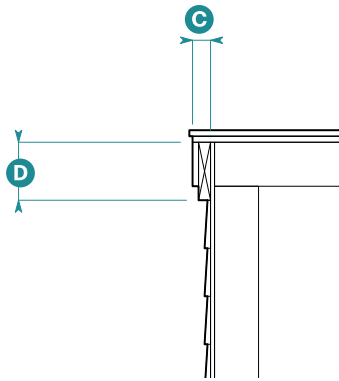
#### Wall Inset Dimensions

Width 8'0" min.; 12'0" max. A

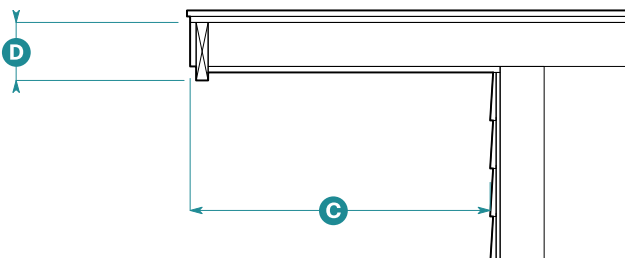
Depth 6'0" min. B

### 4. Base

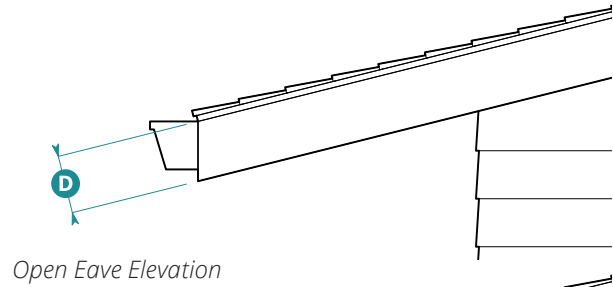
No base is required for this style.



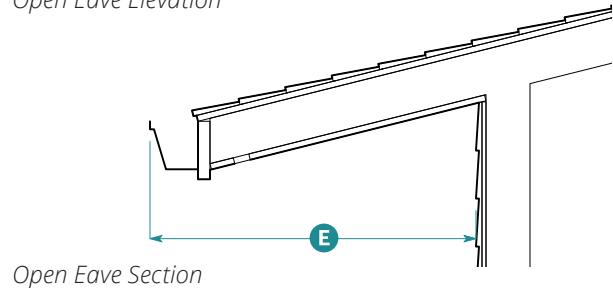
Flush Profile Rake Section



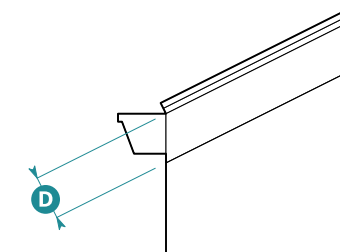
Projecting Profile Rake Section



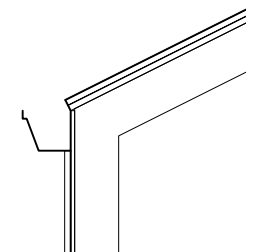
Open Eave Elevation



Open Eave Section



Closed Eave Elevation



Closed Eave Section

5. Building Roof		
Building Roof Standards	Buildings with Half-Story Heights	Buildings with Full-Story Heights
<b>Roof Form</b>		
Type	Shed	Flat
Pitch	2:12 min.; 6:12 max.	N/A
<b>Applicable Subsections</b>		
6. Rake	A	N/A
7. Eave	A	N/A
8. Parapet	N/A	A

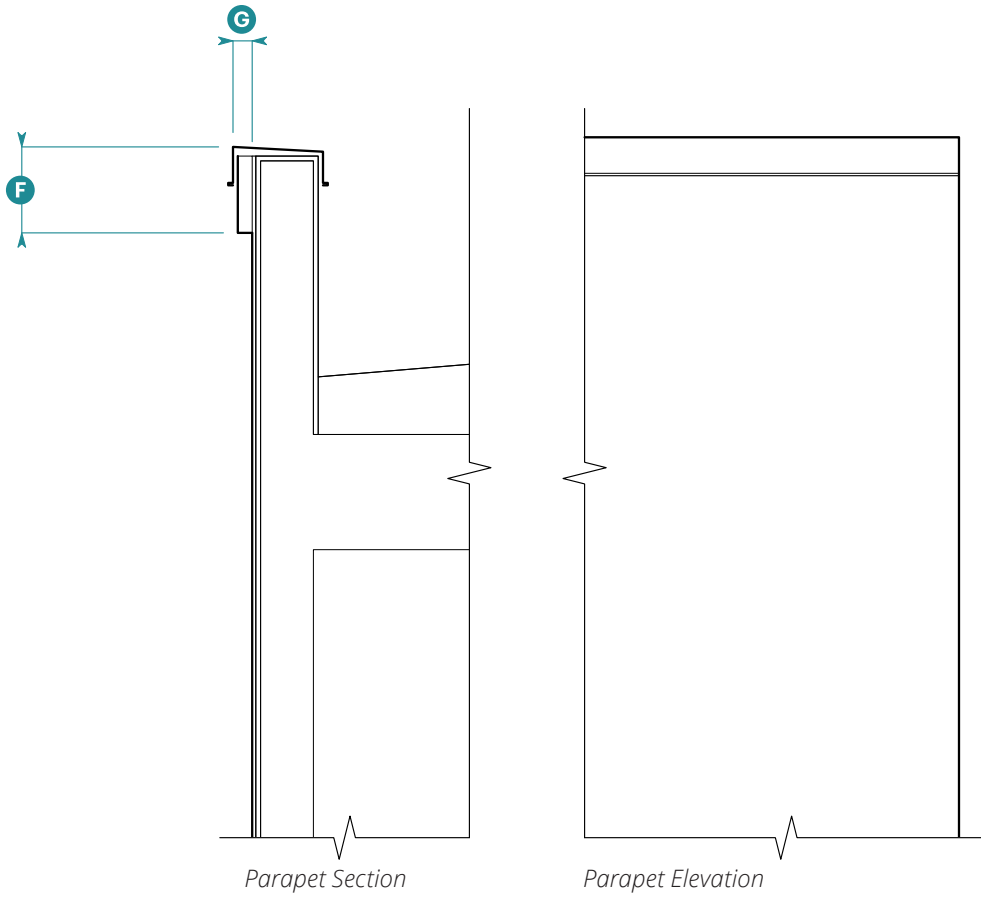
6. Rake		
Standards	Flush Profile	Projecting Profile
Horizontal Projection	No min.; 2" max.	2'6" min.; No max.

See Subsection 7 (Eave) for height standards.

**Key** A = Applicable N/A = Not Applicable

7. Eave		
Standards	Open	Closed
<b>Height</b>		
Overall	8" min.	
Fascia	6" min.	
<b>Horizontal Projection<sup>1</sup></b>		
Overall	36" min.; No max.	0" (flush with facade)

<sup>1</sup>Horizontal projection includes gutter.



8. Parapet		
<b>Height</b>		
Projection	0" min.; 6" max.	F
<b>Horizontal Projection</b>		
Overall	0" min.; 3" max.	G

**9. Windows**

**Opening**

Proportion, Height **H** to Width **I**<sup>2</sup>

Ground floor	2.2 min.
Upper floor	2.0 min.
Dormer	See Subsection 11 (Dormers) for standards.

Typical Sizes, Width **I** x Height **H**

Ground Floor, Typical	3'0" x 6'0"
Ground Floor, Ganged	3'0" x 6'0"
Ground Floor, Picture	4'6" x 6'0"
Upper Floor, Typical	3'0" x 5'6"
Upper Floor, Ganged	3'0" x 5'6"
Upper Floor, Picture	4'6" x 5'6"
Privacy	2'0" x 4'6"

Shape	Square
-------	--------

Operation	Double-Hung, Single-Hung, Awning, Casement
-----------	---

**Window**

Glazing Divisions	None
-------------------	------

Frame Width (Frame + Sash)

At Rail	2.5" min. ± 1/4"	<b>J</b>
At Stile	2.5" min. ± 1/4"	<b>K</b>

Trim Widths<sup>3</sup>

Head	3" min.
Jamb	3" min.
Apron	3" min.

**Window Frame Recess**

Depth	2" min.
-------	---------

**Sill**

Depth	3" min.
-------	---------

**Pediment**

Allowed	No
---------	----

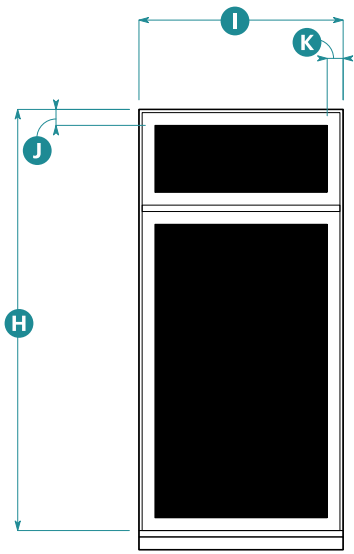
**Mullions**

Mullions required between ganged windows.

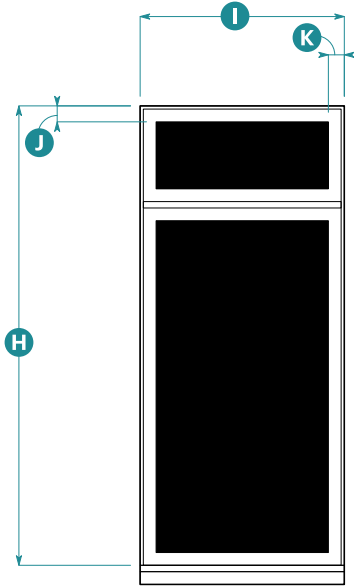
"Typical" refers to a regular recurring window (i.e., size or lite pattern) on a facade.

<sup>2</sup>Picture windows shall be wider than typical windows and equal in height to windows on the same floor.

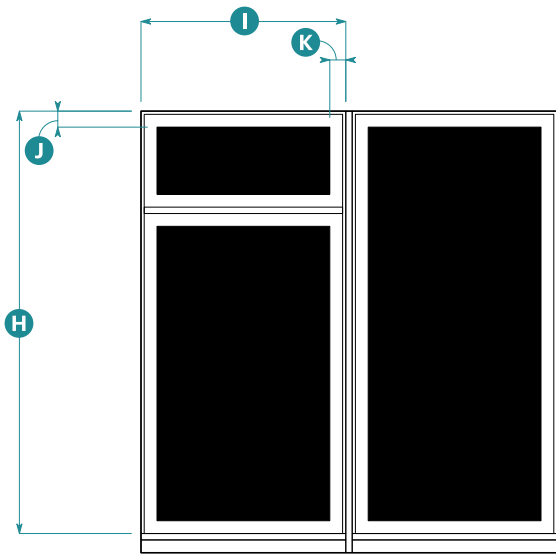
<sup>3</sup>Trim required for windows only on buildings or parts of buildings with lap siding.



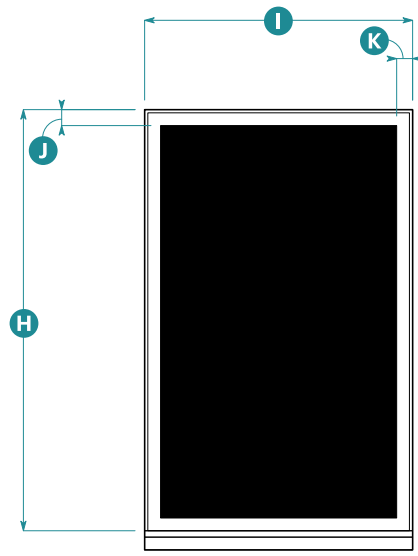
Upper Floor Typical Window Elevation



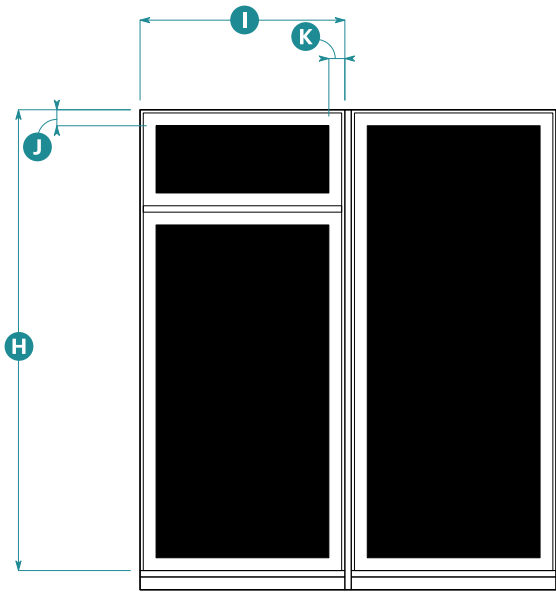
Ground Floor Typical Window Elevation



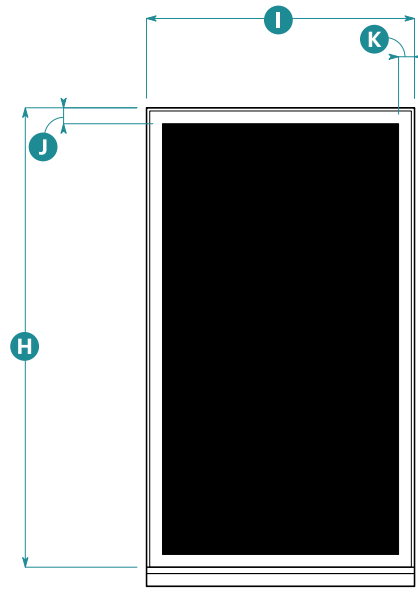
*Upper Floor Ganged Window Elevation*



*Upper Floor Picture Window Elevation*



*Ground Floor Ganged Window Elevation*

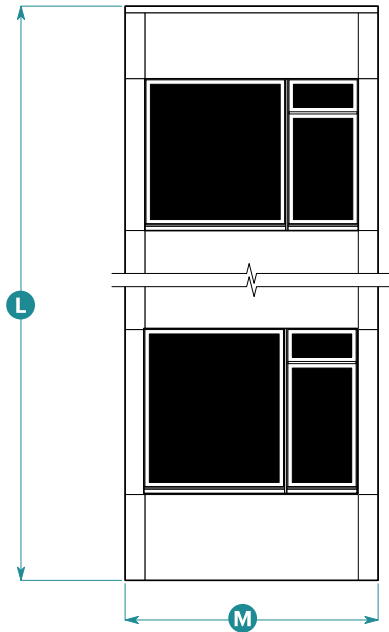


*Ground Floor Picture Window Elevation*

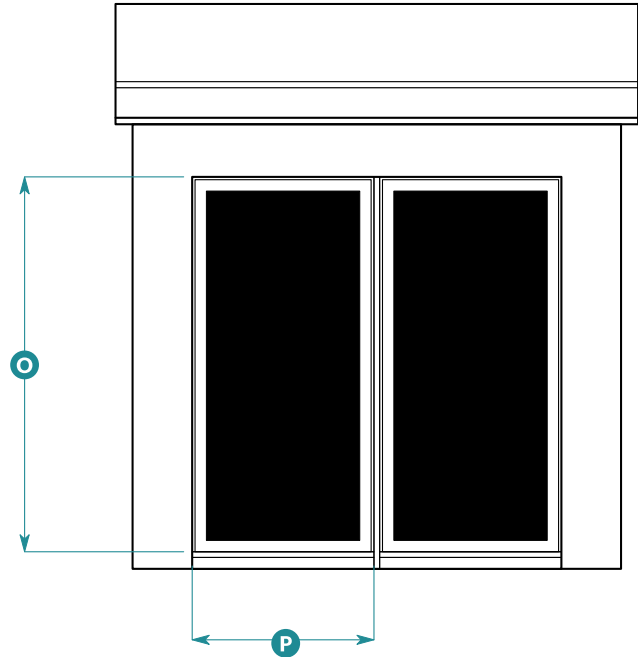




Bay Window Plan



Bay Window Elevation



Dormer Elevation

**10. Bay Windows**

**Form**

Type Square<sup>4</sup>

**Size**

Height L

On buildings with heights up to 3 stories 2 stories max.

Width 6'0" min.; 12'0" max. M

Depth 1'0" min.; 3'0" max. N

**Additional Standards**

Multi-story bay window form shall be vertically continuous.  
 Continuous horizontal articulation on building shall wrap bay form.

<sup>4</sup>Corner bay may be turned on side to be rotated 45 degrees from building corner.

**11. Dormers**

**Roof Form**

Type Shed

Pitch 2:12 min.; 6:12 max.

**Window**

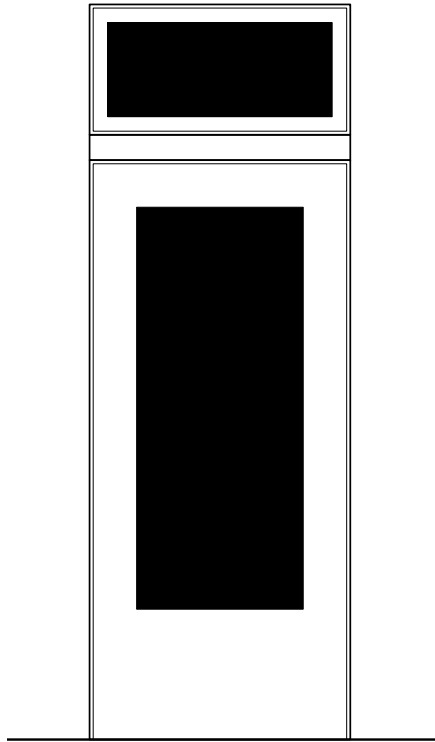
Proportion, Height 2.0 min.

O to Width P

Width 2'6" min. P

Dormers allowed only for buildings with half stories.

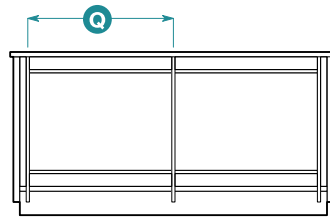
See Subsections 6 (Rake), 7 (Eave), and 9 (Windows) for additional standards.



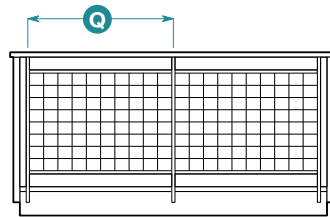
Entry Door Elevation

12. Entry Doors	
Surround <sup>5</sup>	
Head Width	4" min.
Jamb Width	4" min.
Additional Elements	
Transom	Allowed
Pediment	Not Allowed

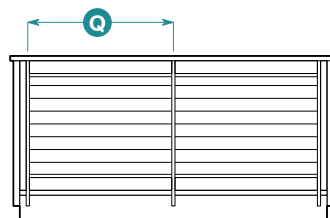
<sup>5</sup>Surround required for doors only on buildings or parts of buildings with lap siding.



Type 1  
Panel Guardrail



Type 2  
Mesh Guardrail

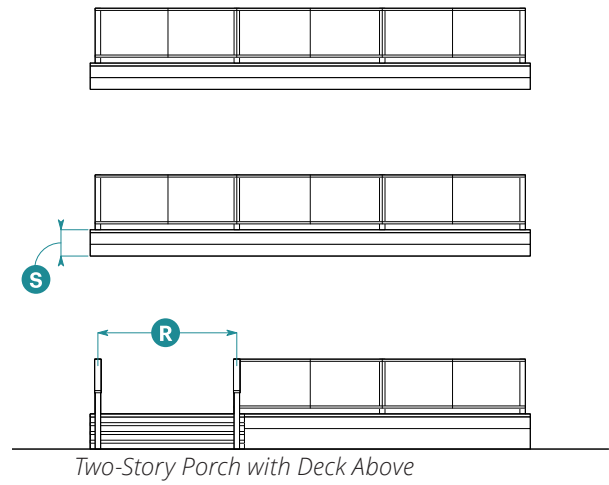
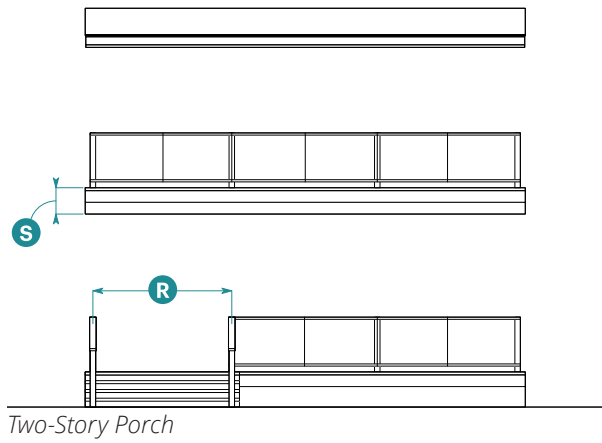
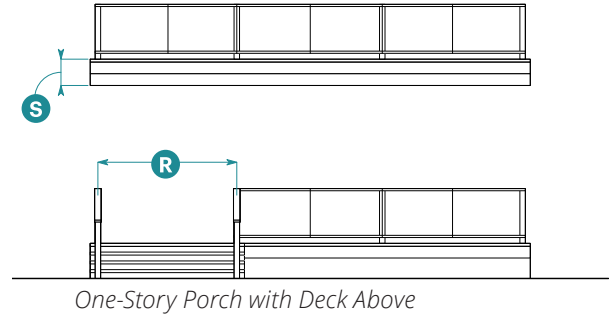
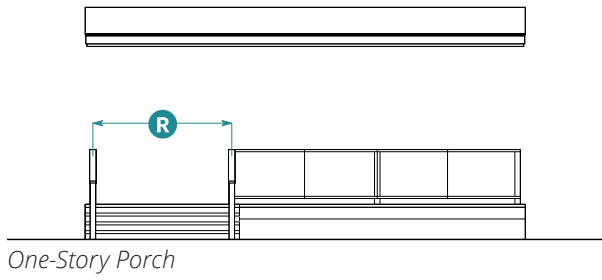


Type 3  
Horizontal Guardrail

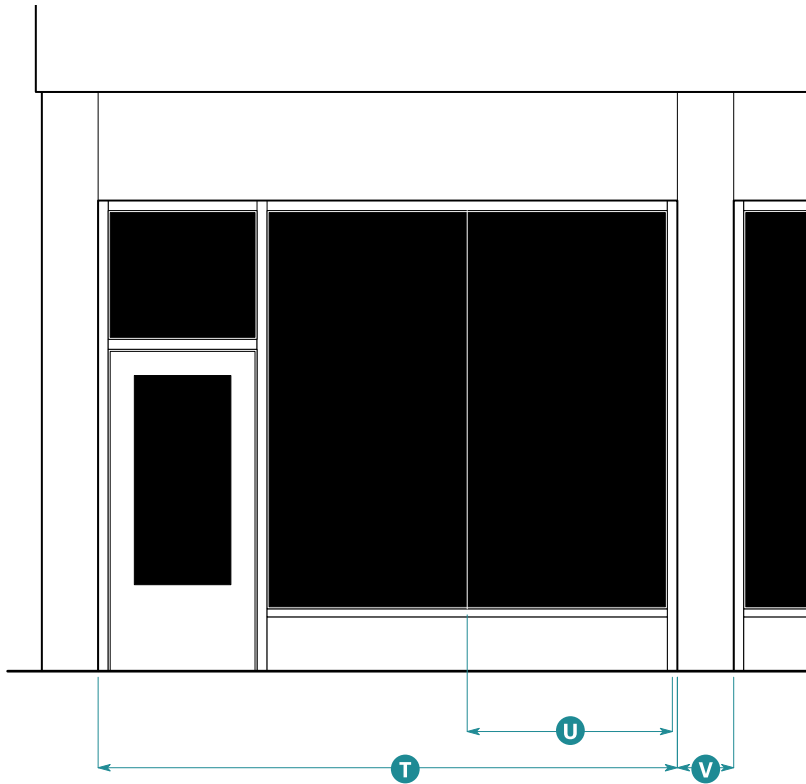
Balcony Front Elevation

13. Balconies	
Allowed Materials	
Type 1 - Panel Guardrail	
Post	Metal
Baluster	Metal panel
Handrail	Metal, glass
Fascia	Metal, composite wood, wood
Type 2 - Mesh Guardrail	
Post and Handrail	Metal
Baluster	Metal mesh
Fascia	Metal, composite wood, wood
Type 3 - Horizontal Guardrail	
Post and Handrail	Metal
Baluster	Metal, steel cable
Fascia	Metal, composite wood, wood
Size	
Overall Balcony Width	10'0" max.
Width Between Posts	3' min.

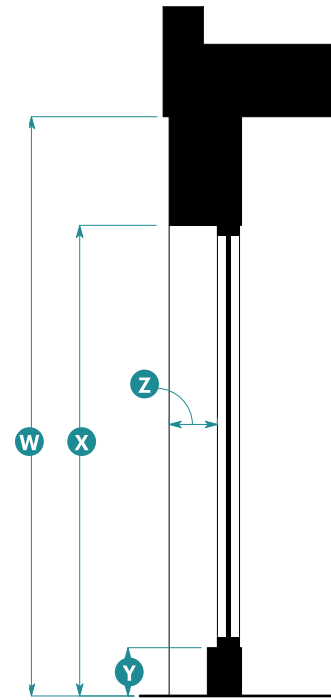




14. Porches	
Columns	
Shape	Cantilevered (no columns) or Pilotis
Diameter	4" max.
Spacing	8'0" max. on center <span style="float: right;">R</span>
Entablature	
Height of Entablature Supporting Deck	
Overall	10" min. <span style="float: right;">S</span>



Storefront Elevation



Storefront Section

**15. Storefronts**

**Width**

Storefront Module	10'0" min.; 15'0" max.	T
Display Window	3'0" min.; 4'0" max.	U
Distance Between Storefront Modules	1'0" min.; 2'0" max.	V

**Height**

Overall	12'0" min.	W
Head Height	11'0" min.	X
Base	8" min.; 2'0" max.	Y

**Horizontal Recess**

Depth	6" min.; 3'0" max.	Z
-------	--------------------	---

Base shall be continuous, unless divided by pilaster, and align with base height of building (if any).

<b>16. Materials</b>	
<b>Element</b>	<b>Allowed Materials</b>
<b>Wall</b>	
Wall Cladding	Lap siding, composite wood, wood, fiber cement, stucco, metal panel
<b>Base or Foundation</b>	
Base or Foundation	Brick, concrete, stone, stucco, composite wood, wood, fiber cement
<b>Roof and Roof Elements</b>	
Roofing	Asphalt shingles, wood shingles, standing seam metal
Rake and Eave	Composite wood, wood, steel
Gutter	Metal box
<b>Windows, Bay Windows, and Entry Doors</b>	
Entry Door	Wood, aluminum, fiberglass, composite wood
Window Frames	Wood, aluminum clad wood, aluminum, fiberglass
Glazing	Clear glass; shall not be tinted, mirrored, or colored
<b>Balconies</b>	
See Subsection 13 (Balconies) for allowed materials.	
<b>Porches</b>	
Columns	Composite wood, wood, fiberglass, metal
Railing	Composite wood, wood, metal
<b>Storefronts</b>	
Storefront	Composite wood, wood, metal
Storefront Base	Stucco, concrete

**22.08.060 Craftsman**



*General note: The images above and the descriptions in Subsections 1 and 2 below are intended to provide a brief overview of the architectural style and are descriptive, not regulatory.*

**1. Description of Style**

The Craftsman style emerged in the American west inspired by the English Arts and Crafts movement. The Craftsman bungalow house was prevalent from the 1900's to the 1940's. Since that time, it has adapted to multifamily and mixed-use prototypes.

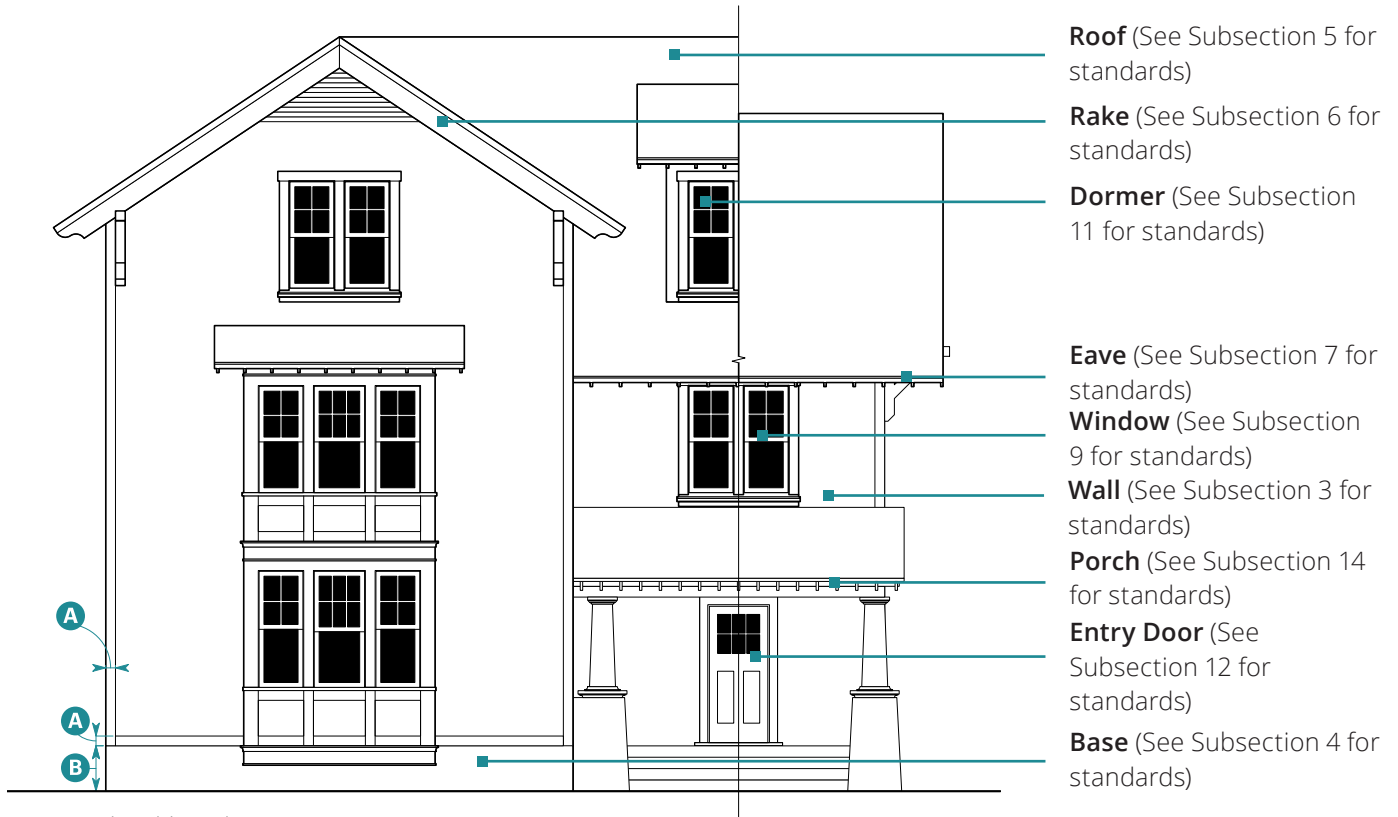
**2. Typical Characteristics**

- Low-pitched roofs with deep eaves and exposed rafter tails
- Horizontally proportioned openings made from ganged vertical windows
- Emphasis on natural materials including wood shingles
- Asymmetrical composition with wall plane broken by projecting gable ends
- Wall plane broken by projecting and/or recessed elements



# Elements of Craftsman Style – Multifamily Prototype

Note: The image below is intended to provide a reference for architectural elements and is illustrative, not regulatory. It is not an exhaustive list of applicable standards.



Prototypical Building Elevation

3. Wall	
Trim <sup>1</sup>	
Width	4" min. <span style="float: right;">A</span>

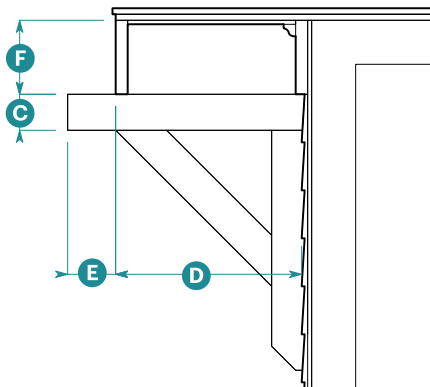
<sup>1</sup>Trim not required on buildings or portions of buildings where stucco is the primary wall material.

4. Base		
Height	1'0" min.; 1/2 story max.	B

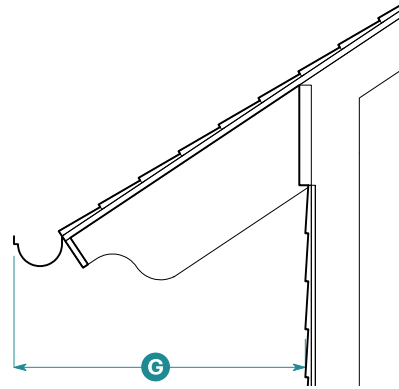
# Elements of Craftsman Style – Mixed-Use Prototype

Note: The image below is intended to provide a reference for architectural elements and is illustrative, not regulatory. It is not an exhaustive list of applicable standards.

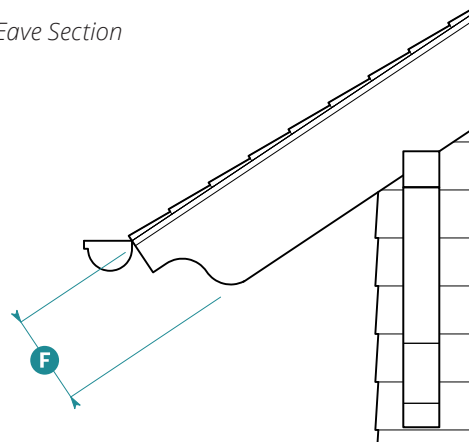




Rake Section



Eave Section



Eave Elevation

5. Building Roof		
Building Roof Standards	Sloped Roof	Flat Roof
<b>Applicable Subsections</b>		
Subsection 6 (Rake)	A	N/A
Subsection 7 (Eave)	A	N/A
Subsection 8 (Parapet)	N/A	A
<b>Form</b>		
Pitch	4:12 min.; 10:12 max.	N/A

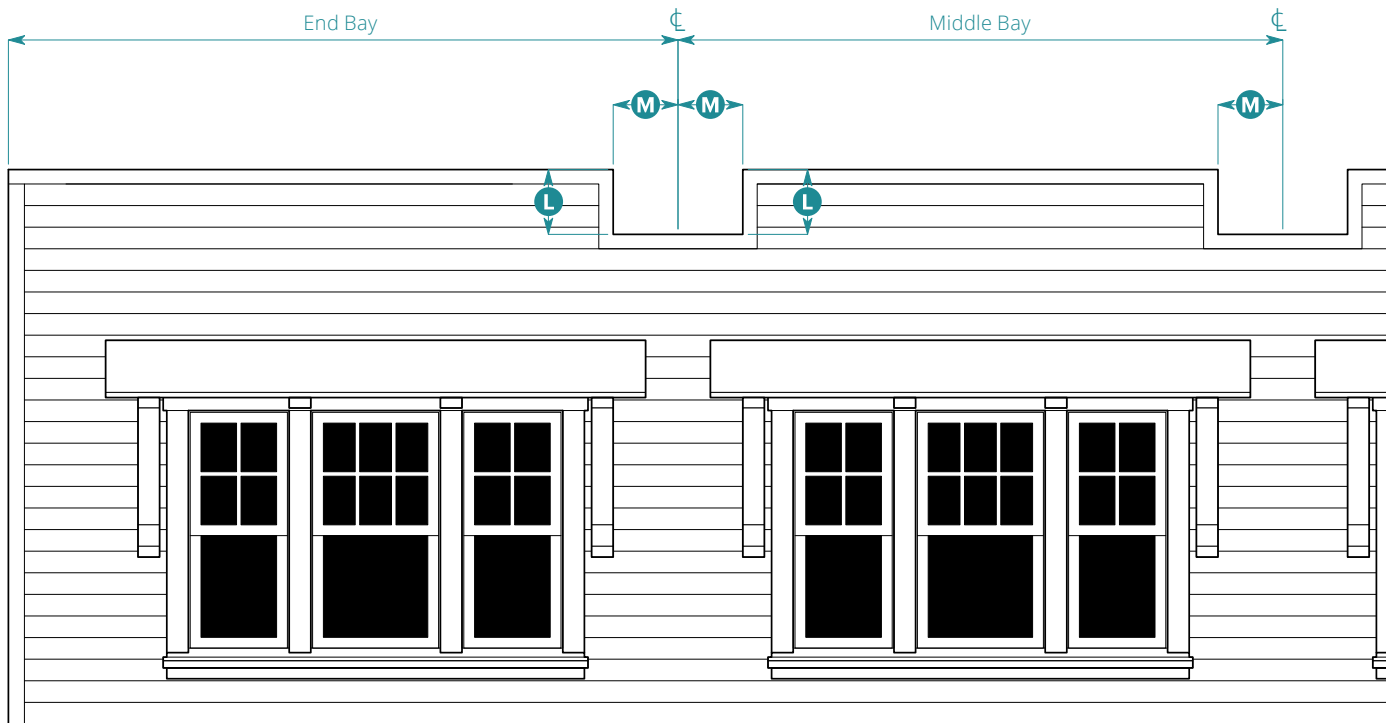
6. Rake		
<b>Height</b>		
Bracket Bracing Member	4" min.	C
<b>Horizontal Projection</b>		
Projection to Fascia	1'8" min. 3'0" max;	D
Bracket Projection Beyond Fascia	No min.; 1'0" max.	E

See Subsection 7 (Eave) for height standards.

**Key** A = Applicable N/A = Not Applicable

7. Eave		
<b>Allowed Types</b>		
Eave Types	Open	
<b>Height</b>		
Fascia	10" min.	F
<b>Horizontal Projection<sup>2</sup></b>		
Overall	2'6" min.	G

<sup>2</sup> Horizontal projection includes gutter.



Parapet Elevation

**8. Parapet**

**Canopy**

Parapet may include canopy.

Eave Height	6" min.	<b>H</b>
Horizontal Projection <sup>3</sup>	3'0" min.	<b>I</b>
Required Support Elements	Brackets	
Bracket Width	4" min.	<b>J</b>
Roof Pitch	3:12 min.	<b>K</b>

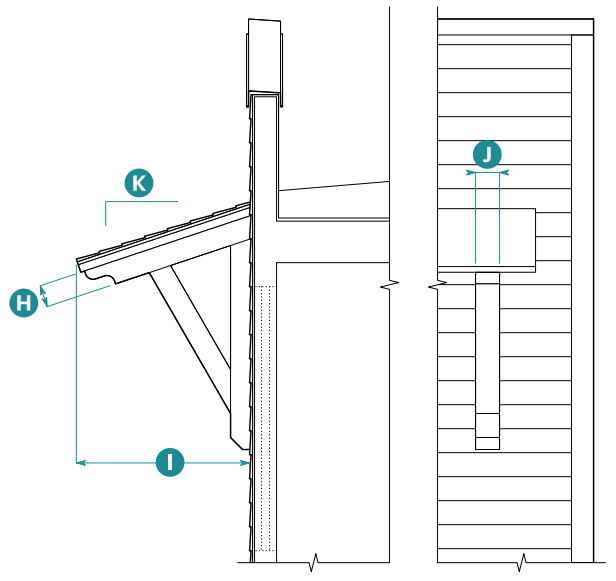
**Crenellation**

Parapet shall be crenellated.

Crenel Height	1'0" min.	<b>L</b>
Width, from Center Line	1'0" min.	<b>M</b>

Crenel may not occur at building corner or end bays.

<sup>3</sup>Horizontal projection includes gutter.



Parapet Section

Parapet Elevation

**9. Windows**

**Opening**

Proportion, Height **N** to Width **O**<sup>4</sup>

Ground Floor	2.0 min.
Upper Floor	1.75 min.
Dormer	See Subsection 11 (Dormers) for standards.

Typical Sizes, Width **O** x Height **N**

Ground Floor, Typical	3'0" x 6'0"
Ground Floor, Ganged	2'4" x 6'0"
Ground Floor, Picture	4'6" x 6'0"
Upper Floor, Typical	3'0" x 5'6"
Upper Floor, Ganged	2'4" x 5'6"
Upper Floor, Picture	4'6" x 5'6"
Privacy	2'0" x 4'0"

Shape	Square
Operation	Single Hung, Double Hung, Casement

**Window**

Glazing Divisions	6 over 1; 4 over 1; 10 over 1
-------------------	-------------------------------------

Frame Width (Frame + Sash)		
At Rail	2.5" min. ± 1/4"	<b>P</b>
At Stile	2.5" min. ± 1/4"	<b>Q</b>

Trim Widths		
Head	6" min.	<b>R</b>
Jamb	6" min.	<b>S</b>
Apron	3" min.	<b>T</b>

**Window Frame Recess**

Depth	2" min.
-------	---------

**Sill**

Depth	3" min.
-------	---------

**Pediment**

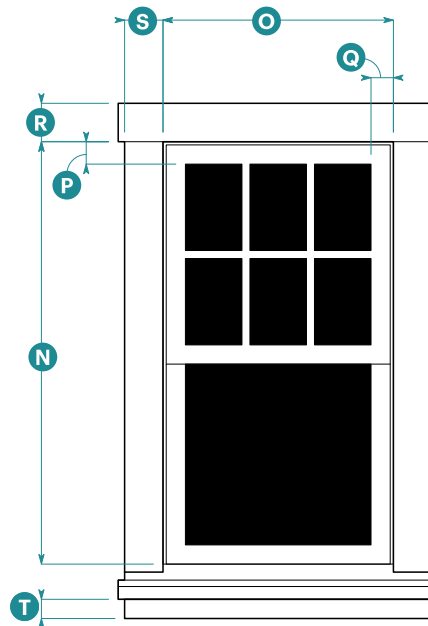
Allowed	No
---------	----

**Mullions**

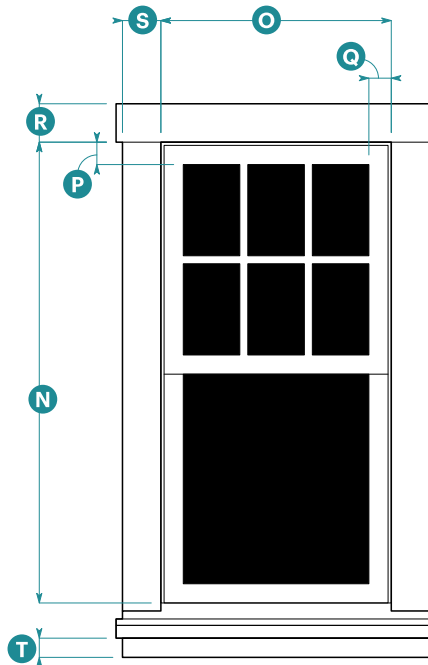
Mullions required between ganged windows.

"Typical" refers to a regular recurring window (i.e., size or lite pattern) on a facade.

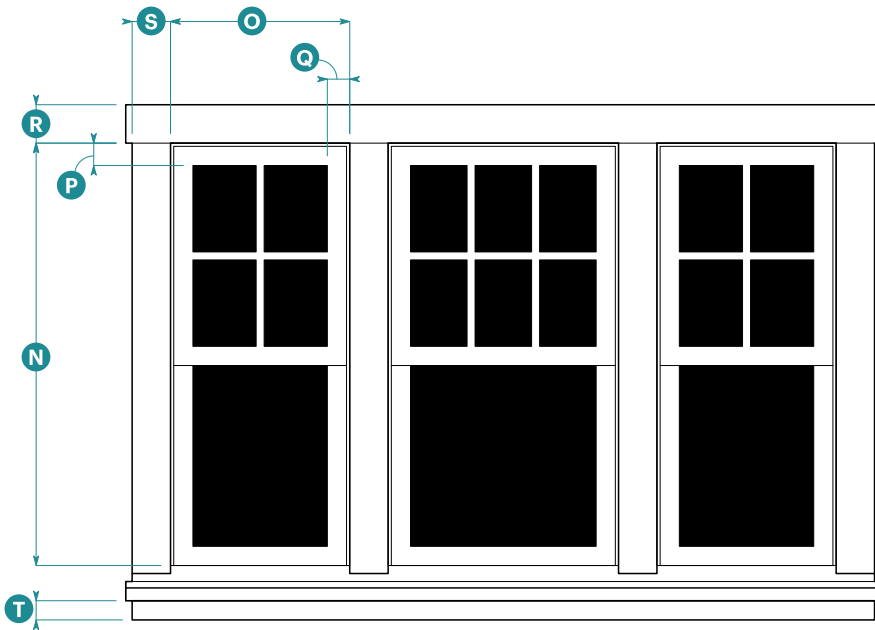
<sup>4</sup>Picture windows shall be wider than typical windows and equal in height to windows on the same floor.



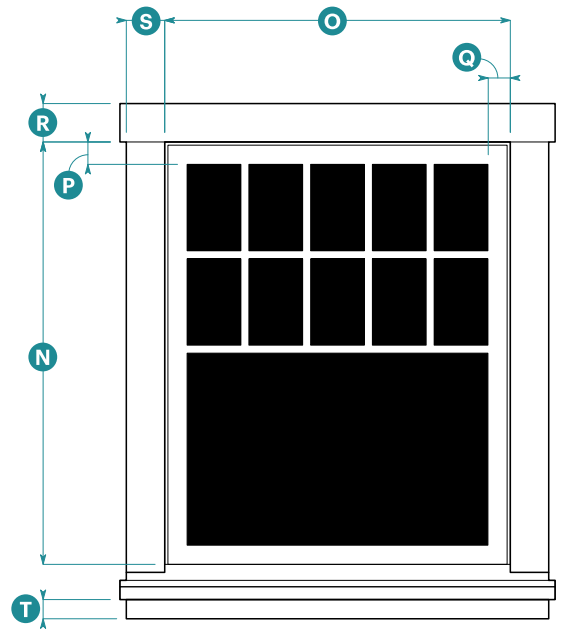
Upper Floor Typical Window Elevation  
6 over 1



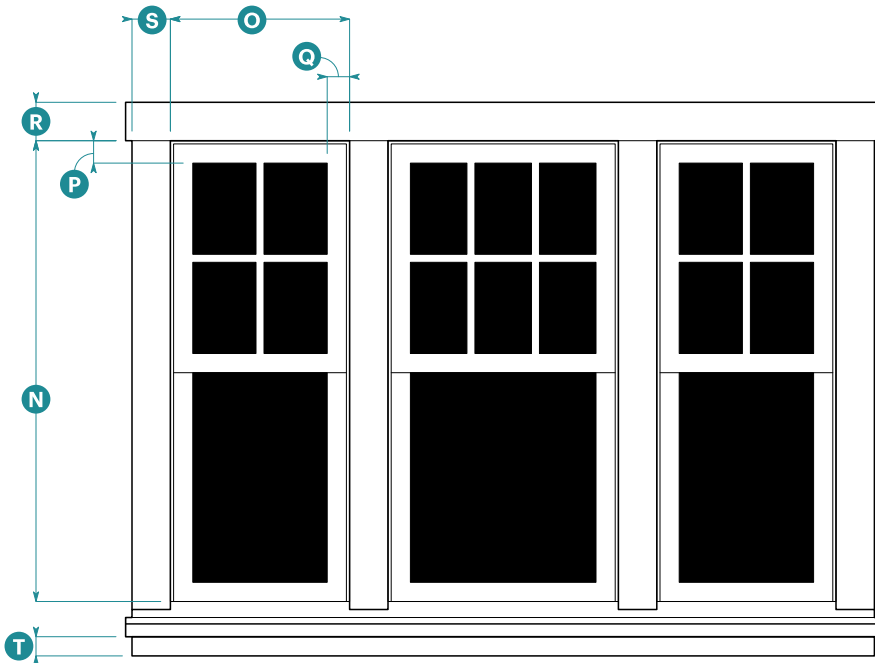
Ground Floor Typical Window Elevation  
6 over 1



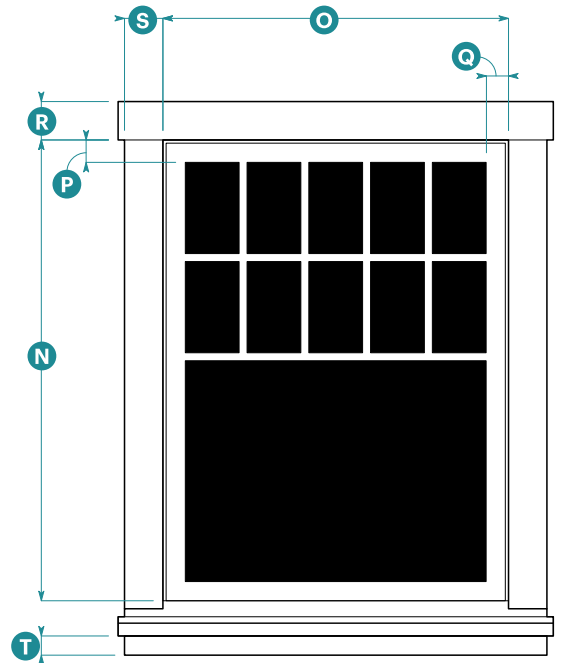
*Upper Floor Ganged Window Elevation  
4 over 1 and 6 over 1*



*Upper Floor Picture Window Elevation  
10 over 1*



*Ground Floor Ganged Window Elevation  
4 over 1 and 6 over 1*

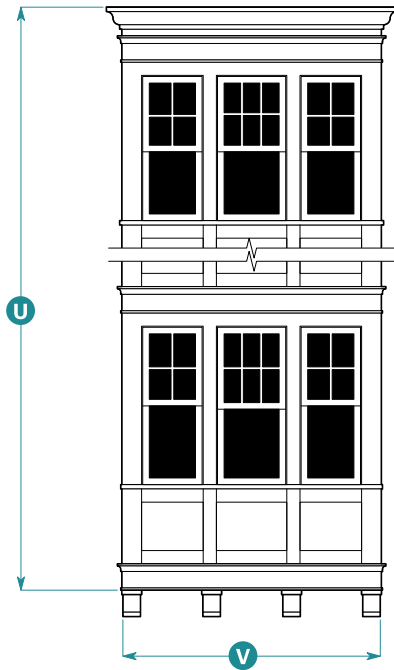


*Ground Floor Picture Window Elevation  
10 over 1*

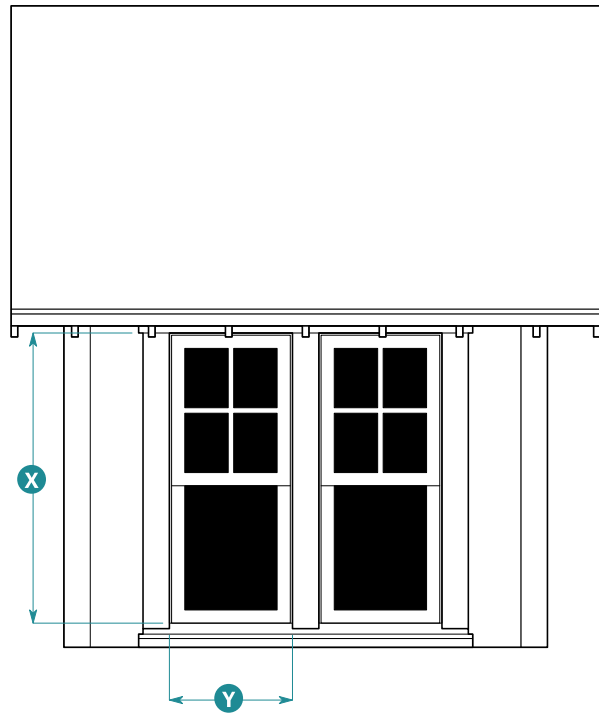




Bay Window Plan



Bay Window Elevation



Dormer Elevation

**10. Bay Windows**

**Form**

Type Square<sup>5</sup>

**Size**

Height U  
 On buildings with heights up to 3 stories 2 stories max.

Width 6'0" min.; 12'0" max. V

Depth 1'0" min.; 3'0" max. W

**Cornice Types**

- Building parapet wraps bay.
- Bay stops below building eave (bay has own cornice).
- Bay returns into building eave (bay never projects above the building eave).

<sup>5</sup>Corner bay may be turned on side to be rotated 45 degrees from building corner.

**10. Bay Windows (Continued)**

**Additional Standards**

- Bay depth not allowed to project beyond eave depth.
- Multi-story bay window form shall be vertically continuous.
- Continuous horizontal articulation on building shall wrap bay form.

**11. Dormers**

**Roof Form**

Type Shed or Gable  
 Pitch 2:12 min.; 5:12 max.

**Horizontal Projection**

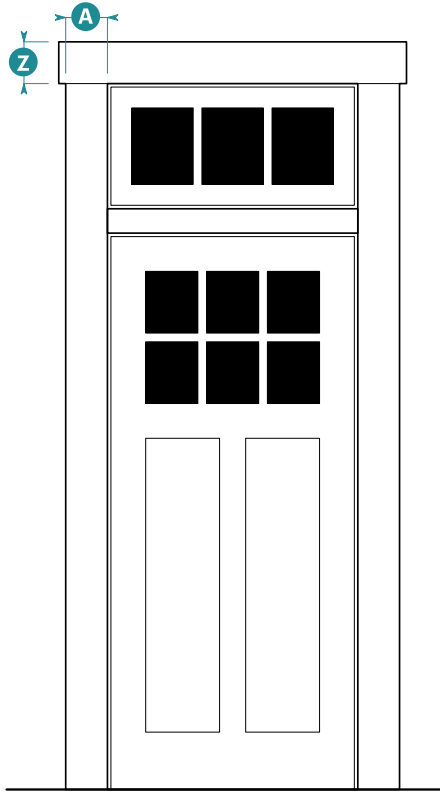
Eave 8" min.  
 Rake 8" min.

**Window**

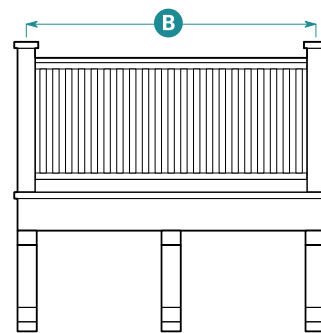
Proportion, Height 1.75 min.  
X to Width Y

- Dormers allowed only for buildings with half stories.
- Pediment not allowed.

See Subsections 6 (Rake), 7 (Eave), and 9 (Windows) for additional standards.



Entry Door Elevation



Balcony Front Elevation

**12. Entry Doors**

**Door**

Number of Panels 2 min.

**Surround**

Head Width 6" min. Z

Jamb Width 4" min. A

**Additional Elements**

Transom Allowed

Pediment Not Allowed

**13. Balconies**

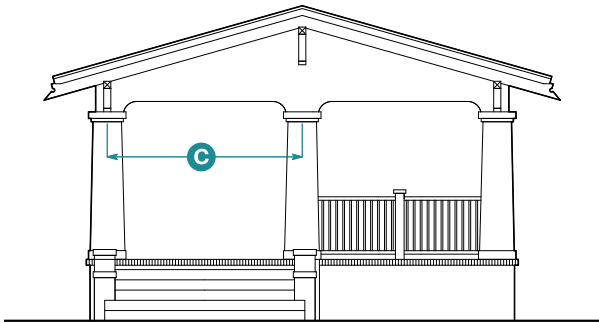
**Allowed Materials**

Post, Baluster, Handrail, and Fascia Metal, composite wood, wood

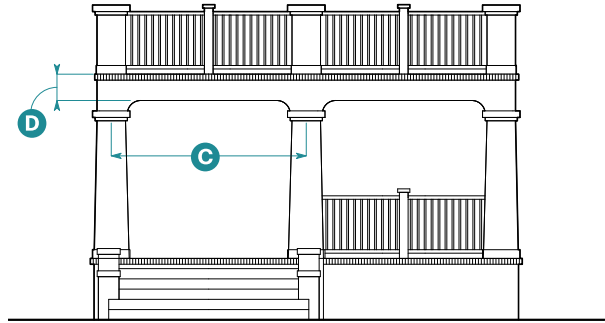
**Size**

Overall Balcony Width 10'0" max.

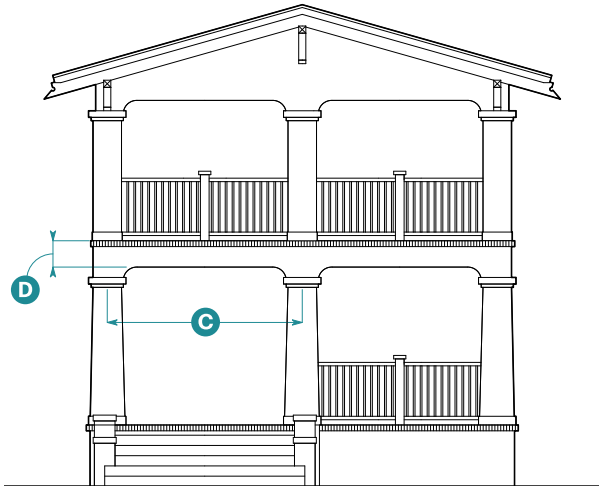
Width Between Posts 3' min. B



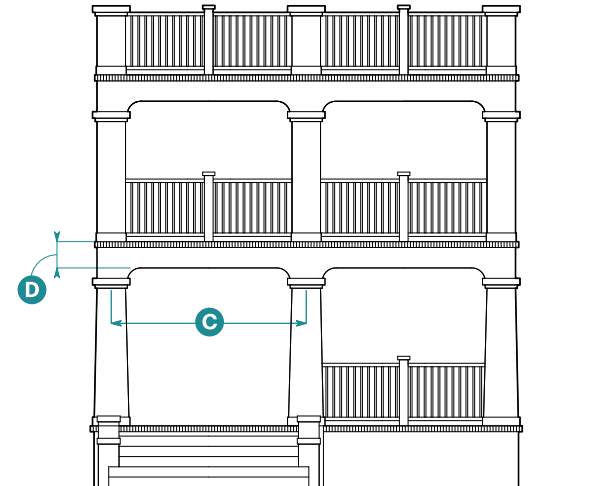
One-Story Porch



One-Story Porch with Deck Above



Two-Story Porch



Two-Story Porch with Deck Above

**14. Porches**

**Columns**

Shape	Square-tapered
Base Width	1'10" min.
Spacing	9'6" min.; 12' max. on center <b>C</b>

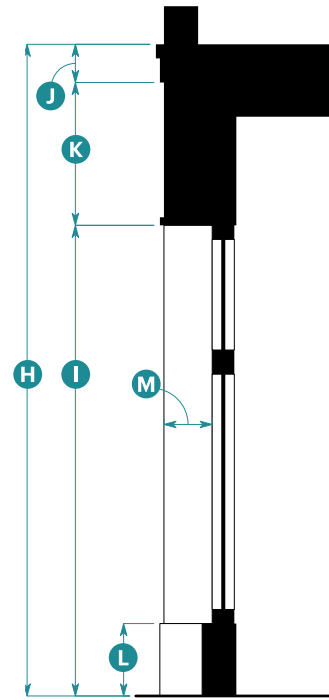
**Entablature**

**Height of Entablature Supporting Deck**

Overall	10" min. <b>D</b>
---------	-------------------



Storefront Elevation



Storefront Section

**15. Storefronts**

**Width**

Storefront Module	10'0" min.; 15'0" max.	<b>E</b>
Display Window	3'0" min.; 4'0" max.	<b>F</b>
Distance Between Storefront Modules	1'0" min.; 2'0" max.	<b>G</b>

**Height**

Overall	13'0" min.	<b>H</b>
Head Height	10'0" min.	<b>I</b>
Cornice	10" min.	<b>J</b>
Signage Band	1'6" min.	<b>K</b>
Base	1'0" min.; 2'0" max.	<b>L</b>

**Horizontal Recess**

Depth	1'0" min.; 2'0" max.	<b>M</b>
-------	----------------------	----------

Base shall be continuous, unless divided by pilaster, and align with base height of building (if any).

Cornice shall be continuous.

<b>16. Materials</b>	
<b>Element</b>	<b>Allowed Materials</b>
<b>Wall</b>	
Wall Cladding	Shingle and lap siding: composite wood, wood, fiber cement; and stucco
<b>Base</b>	
Base or Foundation	Stone, cast stone, painted concrete
<b>Roof and Roof Elements</b>	
Roofing	Asphalt shingles, wood shingles, standing seam metal
Rake and Eave	Composite wood, wood
Cornice	Composite wood, wood
Brackets	Composite wood, wood, fiberglass
Gutter	Metal half-round
<b>Windows, Bay Windows, and Entry Doors</b>	
Trim or Surround	Composite wood, wood, fiber cement
Entry Door	Wood, aluminum, fiberglass, composite
Window Frames	Wood, aluminum-clad wood, aluminum, fiberglass
Glazing	Clear glass; shall not be tinted, mirrored, or colored
<b>Balconies</b>	
See Subsection 13 (Balconies) for allowed materials.	
<b>Porches</b>	
Columns	Composite wood, wood, metal
Railing	Composite wood, wood, metal
<b>Storefronts</b>	
Columns	Composite wood, wood, fiberglass, metal
Storefront Base	Wood panels, brick, stone tile, fiber cement

**22.08.070 East Coast Cottage**



*General note: The images above and the descriptions in Subsections 1 and 2 below are intended to provide a brief overview of the architectural style and are descriptive, not regulatory.*

**1. Description of Style**

East Coast Cottage style buildings are influenced by the shingle style and may take on traditional or contemporary expression. Gabled or gambrel roof forms are used as a major compositional element to emphasize individual bays and create half-story roof forms.

**2. Typical Characteristics**

- Prominent gabled or gambrel roof forms
- Vertically proportioned openings with surround
- Painted trim, often white in color
- Shingle or horizontal lap siding as primary facade materials
- Top story partially within roof with shed dormers



# Elements of East Coast Cottage Style – Multifamily Prototype

Note: The image below is intended to provide a reference for architectural elements and is illustrative, not regulatory. It is not an exhaustive list of applicable standards.



Prototypical Building Elevation

### 3. Wall

No wall standards apply to this style. See Subsection 16 (Materials) for materials standards.

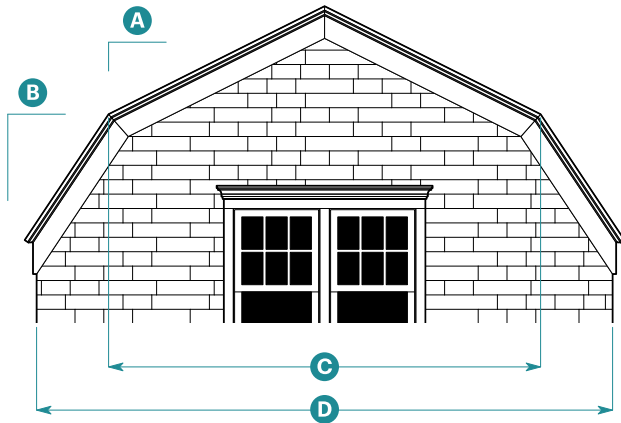
### 4. Base

None required

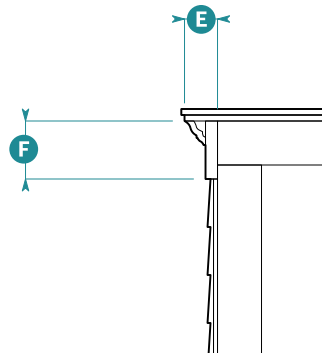
## Elements of East Coast Cottage Style – Mixed-Use Prototype

Note: The image below is intended to provide a reference for architectural elements and is illustrative, not regulatory. It is not an exhaustive list of applicable standards.

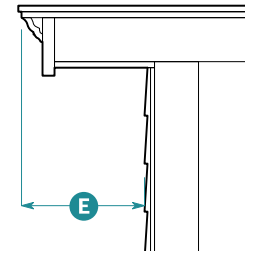




Gambrel Roof Form Elevation



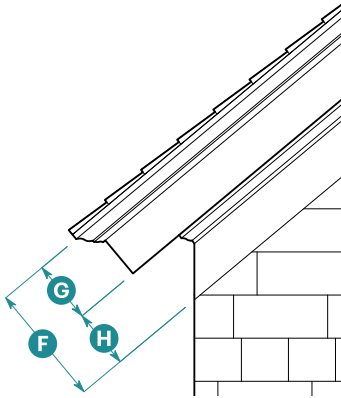
Flush Profile Rake Section



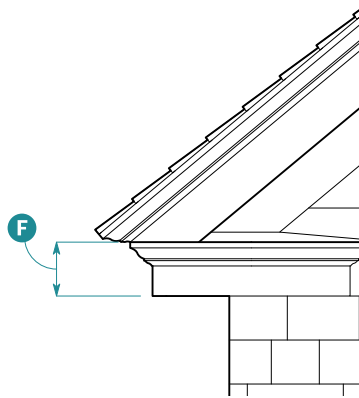
Projecting Profile Rake Section

5. Building Roof		
Building Roof Form		
Allowed Forms	Gable, Gambrel	
<b>Gable</b>		
Pitch	6:12 min., 12:12 max.	
<b>Gambrel</b>		
Pitch		
Top	3:12 min., 9:12 max.	<b>A</b>
Bottom	9:12 min., 24:12 max.	<b>B</b>
Width of Top Pitch	50% min., 75% max. of overall roof width	<b>C</b>

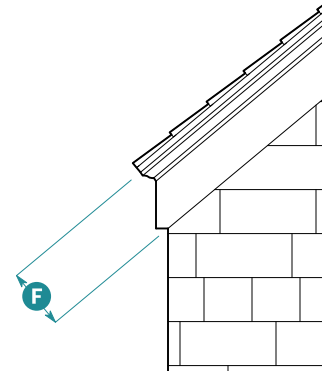
6. Rake		
Standards	Flush Profile	Projecting Profile
Horizontal Projection	No min.; 2" max.	6" min.; 1'0" max. <b>E</b>
See Subsection 7 (Eave) for height standards.		



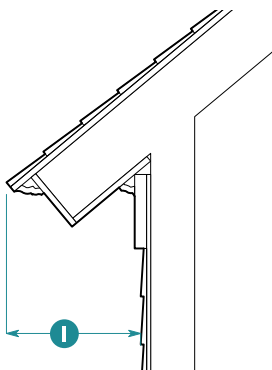
Open Eave Elevation



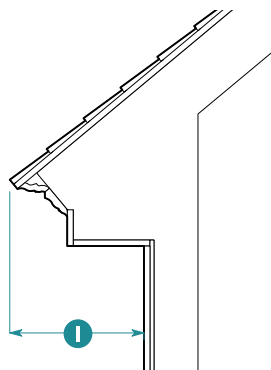
Returned Eave Elevation



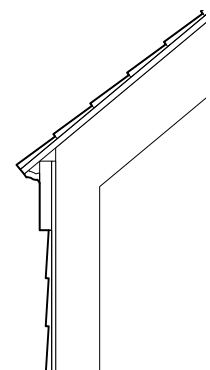
Closed Eave Elevation



Open Eave Section



Returned Eave Section



Closed Eave Section

### 7. Eave

#### Allowed Types

Eave Types Open, Returned, Closed

Standards	Open Eave	Returned Eave	Closed Eave
-----------	-----------	---------------	-------------

#### Height

Overall	1'6" min.	1'6" min.	10" min.	F
Crown Mold and Fascia	10" min.	N/A	N/A	G
Trim Band	8" min.	N/A	N/A	H

#### Horizontal Projection<sup>1</sup>

Overall	1'0" min.	1'0" min.	2" max.	I
---------	-----------	-----------	---------	---

<sup>1</sup>Horizontal projection includes gutter.

### 8. Parapet

No flat roofs are allowed in this style and parapet standards are not applicable. See Subsection 5 (Roof), Subsection 6 (Rake) and Subsection 7 (Eave) for standards applicable to sloped roofs.

**Key** N/A = Not Applicable

**9. Windows**

**Opening**

Proportion, Height <b>J</b> to Width <b>K</b> <sup>2</sup>	
Ground Floor	2.0 min.
Upper Floor	1.75 min.
Dormer	See Subsection 11 (Dormers) for standards.

Typical Sizes, Width **K** x Height **J**

Ground Floor, Typical	3'0" x 6'0"
Ground Floor, Ganged	3'0" x 6'0"
Ground Floor, Picture	4'6" x 6'0"
Upper Floor, Typical	3'0" x 5'6"
Upper Floor, Ganged	3'0" x 5'6"
Upper Floor, Picture	4'6" x 5'6"
Privacy	2'0" x 4'0"

Shape	Square
-------	--------

Operation	Single Hung, Double Hung, Casement
-----------	------------------------------------

**Window**

Glazing Divisions	6 over 1
-------------------	----------

Frame Width (Frame + Sash)

At Rail	2.5" min. ± 1/4"	<b>L</b>
At Stile	2.5" min. ± 1/4"	<b>M</b>

Trim Widths

Head	4" min.	<b>N</b>
Jamb	4" min.	<b>O</b>
Apron	3" min.	<b>P</b>

**Window Frame Recess**

Depth	2" min.
-------	---------

**Sill**

Depth	3" min.
-------	---------

**Pediment**

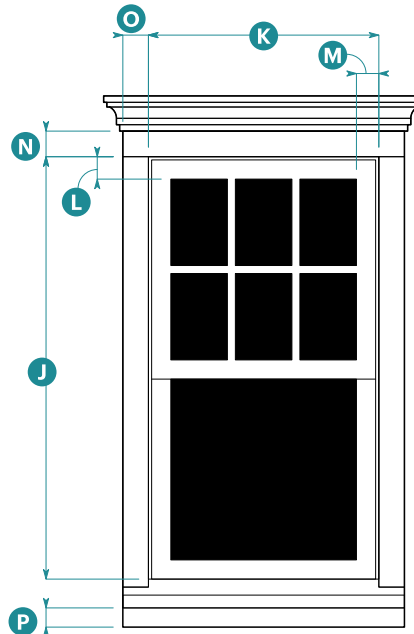
Allowed	No
---------	----

**Mullions**

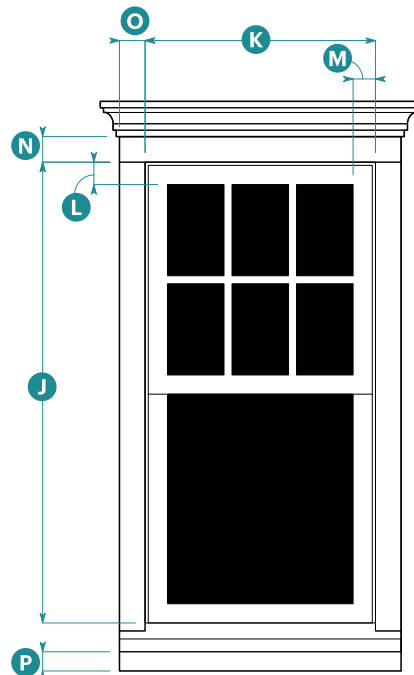
Mullions required between ganged windows.

"Typical" refers to a regular recurring window (i.e., size or lite pattern) on a facade.

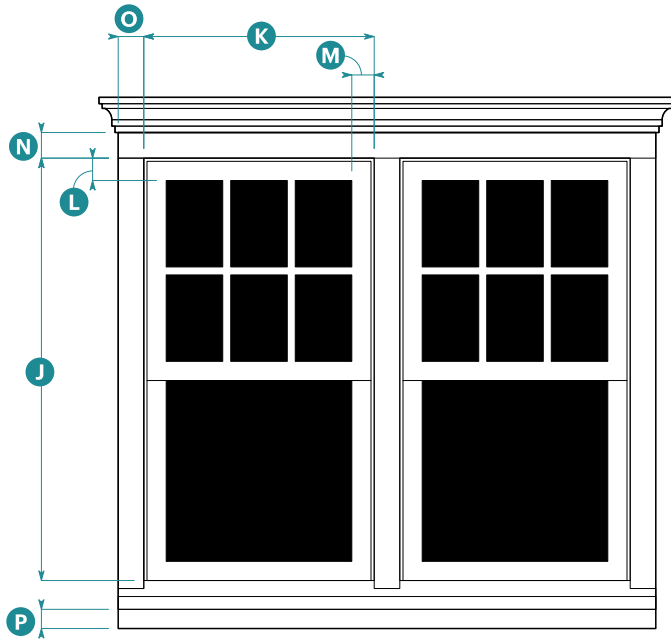
<sup>2</sup>Picture windows shall be wider than typical windows and equal in height to windows on the same floor.



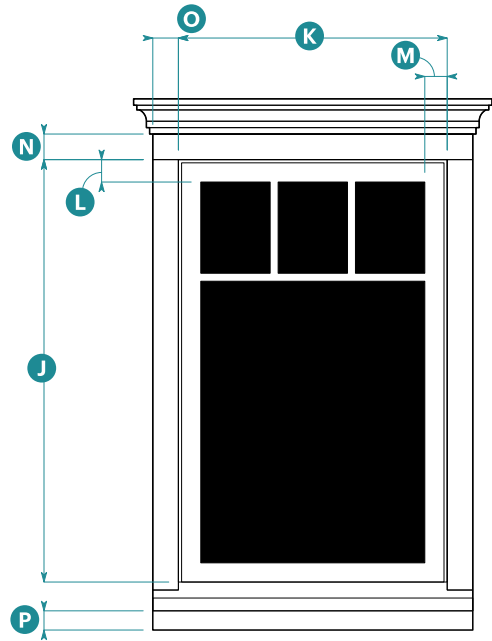
Upper Floor Typical Window Elevation  
6 over 1



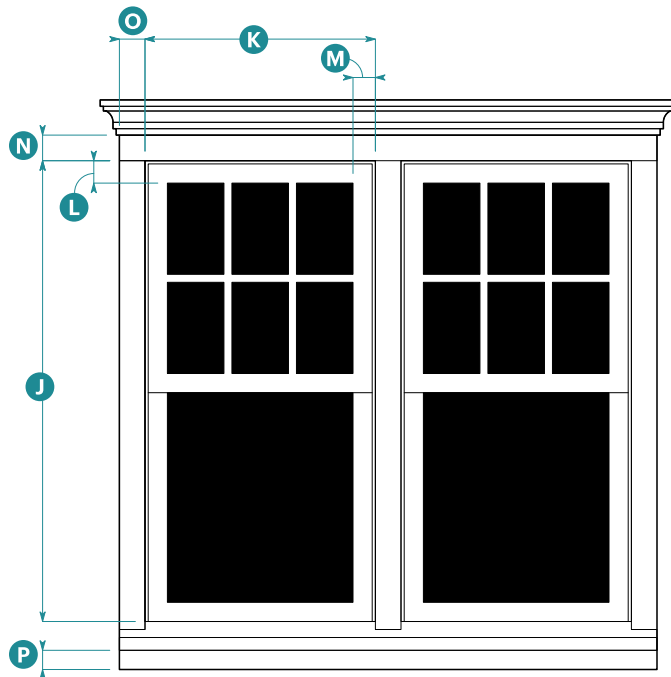
Ground Floor Typical Window Elevation  
6 over 1



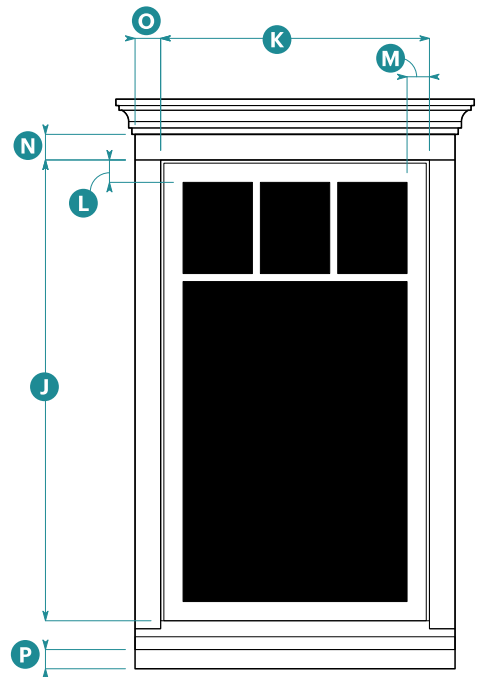
Upper Floor Ganged Window Elevation  
6 over 1



Upper Floor Picture Window Elevation

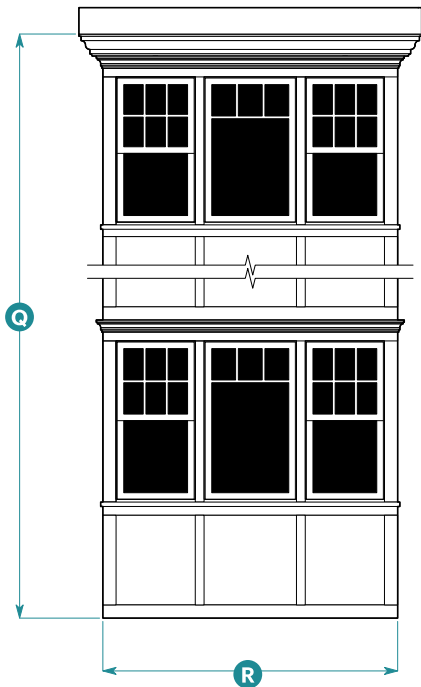


Ground Floor Ganged Window Elevation  
6 over 1

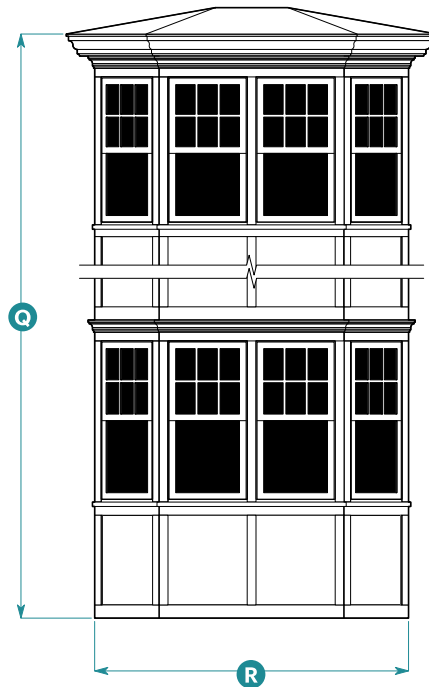


Ground Floor Picture Window Elevation

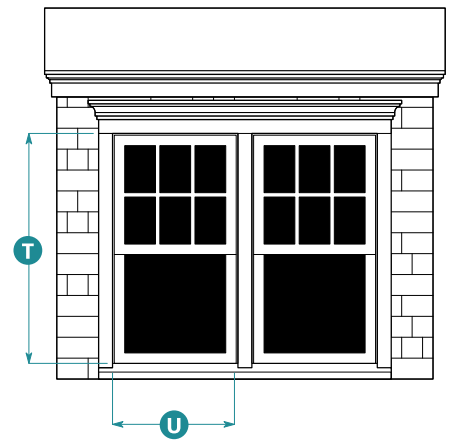




Square Bay Window Elevation



Chamfered Bay Window Elevation



Dormer Elevation

**10. Bay Windows**

**Allowed Types**

Bay Window Types Square,<sup>3</sup> Chamfered

**Chamfered Form Standards**

Interior Angle 30 degrees min.;  
55 degrees max.

Number of Faces 3 or 5

**Size**

Height **Q**

On buildings with heights up to 3 stories 2 stories max.

Width **R**

Depth **S**

**Cornice Types**

Cornice wraps bay.

<sup>3</sup>Corner bay may be turned on side to be rotated 45 degrees from building corner.

**10. Bay Windows (Continued)**

Bay stops below building cornice (bay has own cornice).

Bay returns into building cornice (bay never projects above the building cornice).

**Additional Standards**

Bay depth not allowed to project beyond eave depth.

Multi-story bay window form shall be vertically continuous.

Continuous horizontal articulation on building shall wrap bay form.

**11. Dormers**

**Roof Form**

Type Shed

Pitch 3:12 min.

**Window**

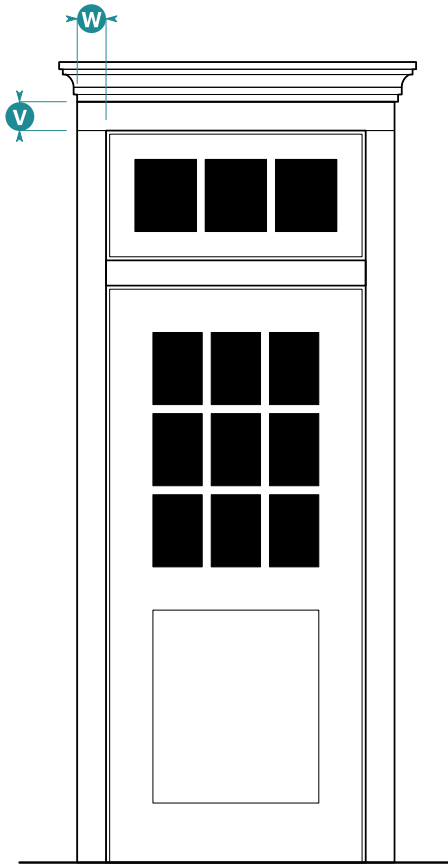
Proportion, Height **T** to 1.75 min.

Width **U**

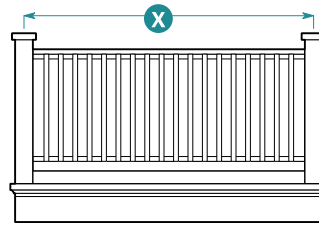
Dormers allowed only for buildings with half stories.

Pediment not allowed.

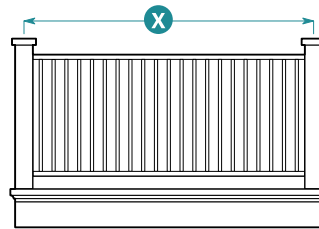
See Subsections 6 (Rake), 7 (Eave), and 9 (Windows) for additional standards.



Entry Door Elevation



Type 1  
Square Guardrail



Type 2  
Metal Guardrail

Balcony Front Elevation

**12. Entry Doors**

**Door**

Number of Panels 2 min.

**Surround**

Head Width 4" min. V

Jamb Width 4" min. W

**Additional Elements**

Transom Allowed

Pediment Allowed

**13. Balconies**

**Allowed Materials**

**Type 1 - Square Guardrail**

Post, Baluster, Handrail, Fascia, and Brackets Metal, composite wood, wood

**Type 2 - Metal Guardrail**

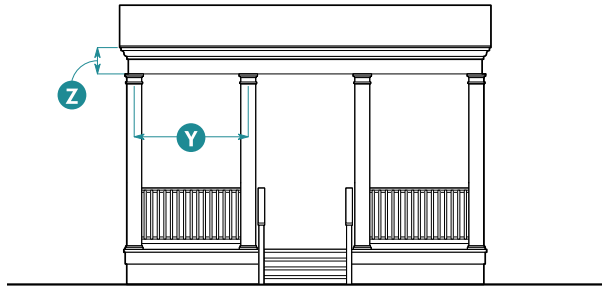
Post, Handrail, Fascia, and Brackets Metal, composite wood, wood

Baluster Metal

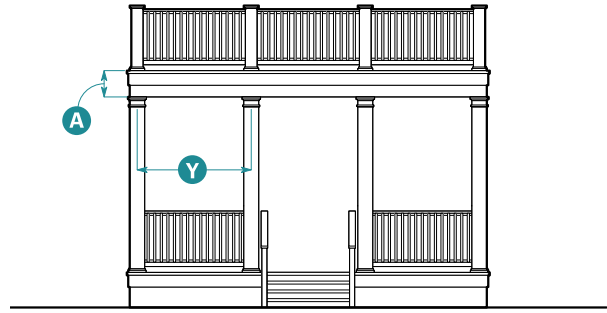
**Size**

Overall Balcony Width 10'0" max.

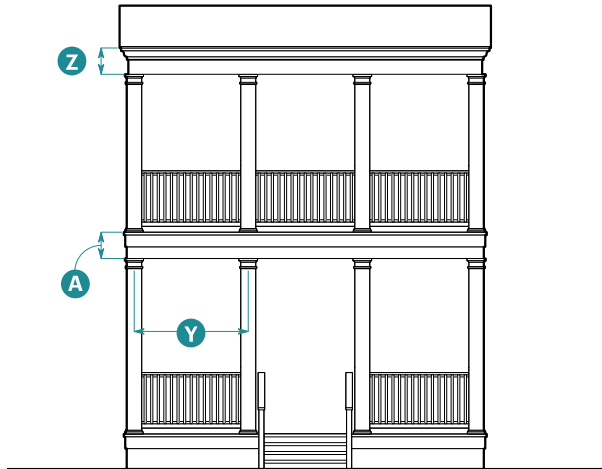
Width Between Posts 3' min. X



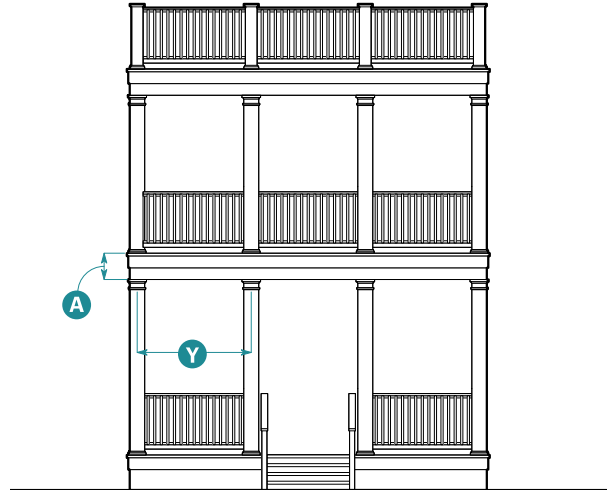
One-Story Porch



One-Story Porch with Deck Above



Two-Story Porch



Two-Story Porch with Deck Above

## 14. Porches

### Columns

Shape Clearly defined capital, base, and shaft;  
square stock with optional detailing

Width 8" min.

Spacing 8'0" max. on center Y

### Entablature

#### Height of Topmost Entablature

Overall 1'6" min. Z

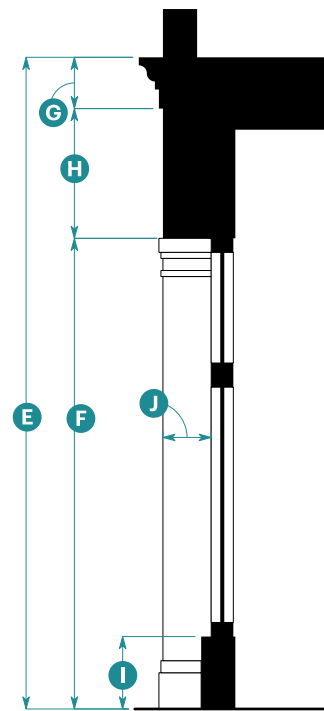
Fascia 10" min.

#### Height of Floor-to-Floor Entablature

Overall 10" min. A



Storefront Elevation



Storefront Section

**15. Storefronts**

**Width**

Storefront Module	10'0" min.; 15'0" max.	<b>B</b>
Display Window	3'0" min.; 4'0" max.	<b>C</b>
Distance Between Storefront Modules	1'0" min.; 2'0" max.	<b>D</b>

**Height**

Overall	13'0" min.	<b>E</b>
Head Height	10'0" min.	<b>F</b>
Cornice	10" min.	<b>G</b>
Signage Band	1'6" min.	<b>H</b>
Base	1'0" min.; 2'0" max.	<b>I</b>

**Horizontal Recess**

Depth	6" min.; 1'0" max.	<b>J</b>
-------	--------------------	----------

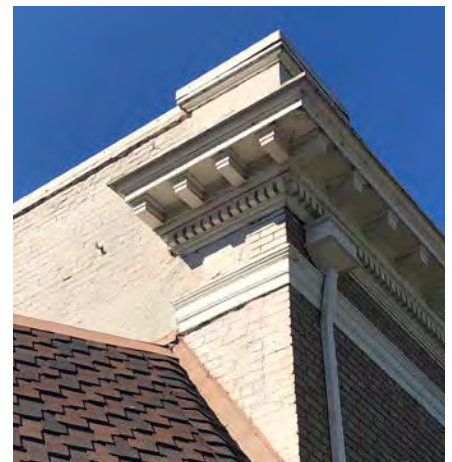
Base shall be continuous, unless divided by pilaster, and align with base height of building (if any).

Cornice shall be continuous.

16. Materials			
Element	Allowed Materials	Required Finishes	Required Colors
<b>Wall</b>			
Wall Cladding	Shingle and lap siding: composite wood, wood, fiber cement; and stucco	Transparent, semi-transparent, or painted	Blacks, greys, browns, or beiges
<b>Base</b>			
Base or Foundation	Stone, cast stone, painted concrete	N/A	N/A
<b>Roof and Roof Elements</b>			
Roofing	Composite (asphalt) shingles, wood shingles, standing seam metal	N/A	
Rake and Eave	Composite wood, wood	N/A	N/A
Cornice	Composite wood, wood	N/A	N/A
Brackets	Composite wood, wood, fiberglass	N/A	N/A
Gutter	Metal half-round	N/A	N/A
<b>Windows, Bay Windows, and Entry Doors</b>			
Trim or Surround	Composite wood, wood, fiber cement	Painted	Whites
Entry Door	Wood, aluminum, fiberglass, composite	N/A	N/A
Window Frames	Wood, aluminum-clad wood, aluminum, fiberglass	N/A	N/A
Glazing	Clear glass; shall not be tinted, mirrored, or colored	N/A	N/A
<b>Balconies</b>			
See Subsection 13 (Balconies) for allowed materials.			
<b>Porches</b>			
Columns	Composite wood, wood, metal	N/A	N/A
Railing	Composite wood, wood, metal	N/A	N/A
<b>Storefronts</b>			
Storefront	Composite wood, wood, fiberglass, metal	N/A	N/A
Storefront Base	Wood panels, brick, fiber cement	N/A	N/A

**Key** N/A = Not Applicable

**22.08.080 Main Street Classical**



General note: The images above and the descriptions in Subsections 1 and 2 below are intended to provide a brief overview of the architectural style and are descriptive, not regulatory.

**1. Description of Style**

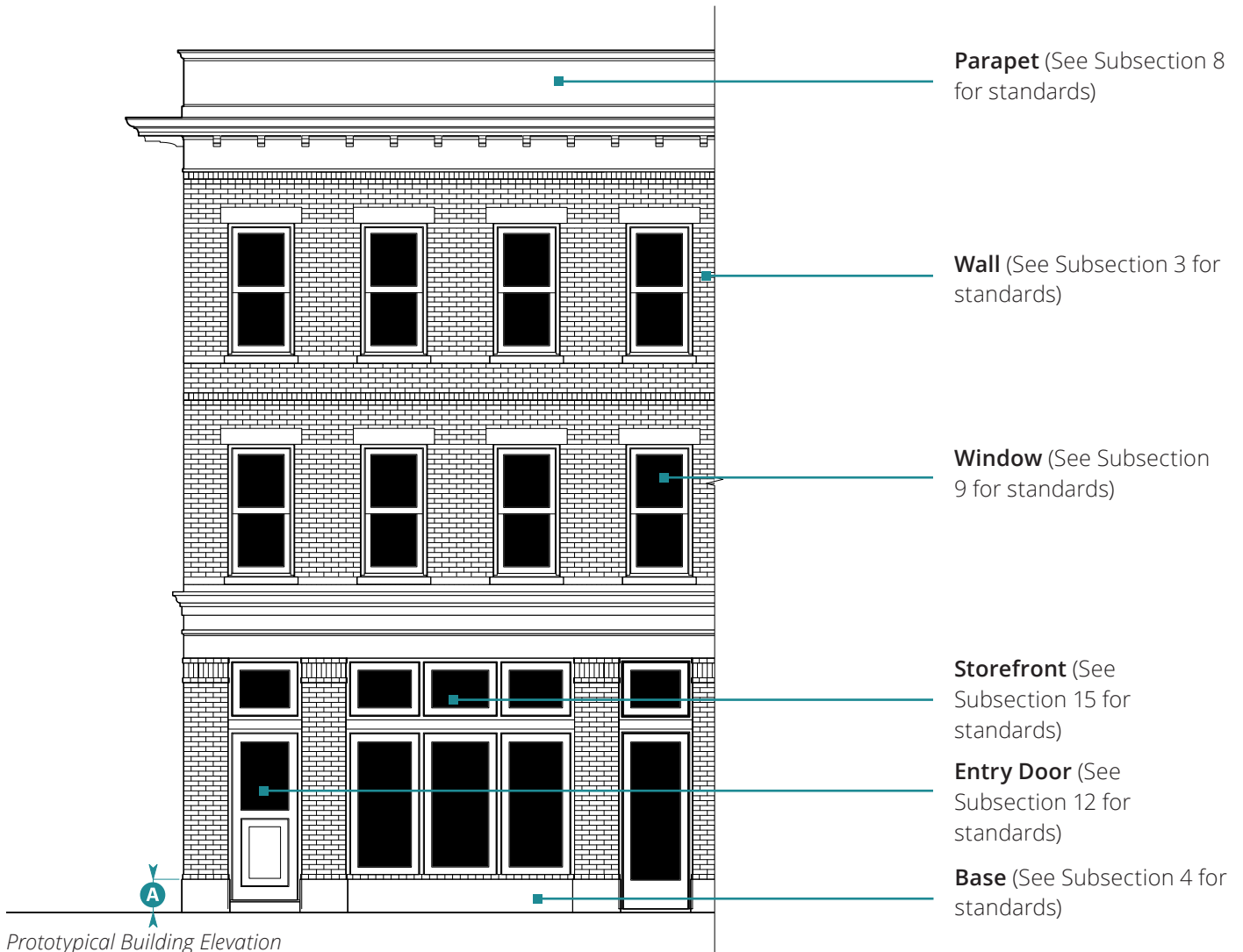
Main Street Classical style buildings combine influences from late 19th century Classical Revival and pre-war American main street architecture. With brick as a primary facade material, facades have a tripartite composition and often introduce ornament in a prominent cornice.

**2. Typical Characteristics**

- Symmetrical facade composition with proportions that imply load-bearing masonry structure
- Prominent cornice with classical detailing and parapet or pedimented roof forms
- Regular pattern of vertically proportioned openings
- Brick and stucco as primary facade materials

# Elements of Main Street Classical Style – Mixed-Use Prototype

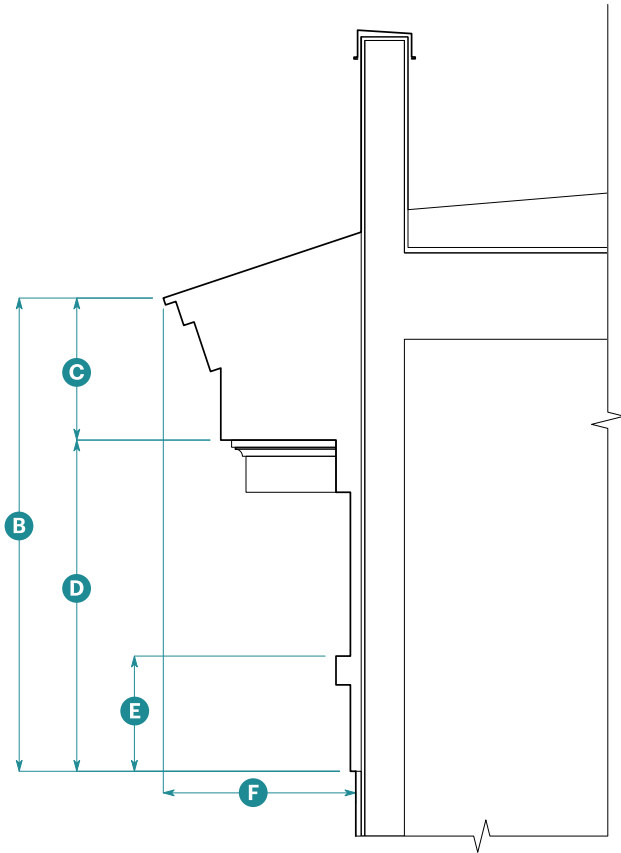
Note: The image below is intended to provide a reference for architectural elements and is illustrative, not regulatory. It is not an exhaustive list of applicable standards.



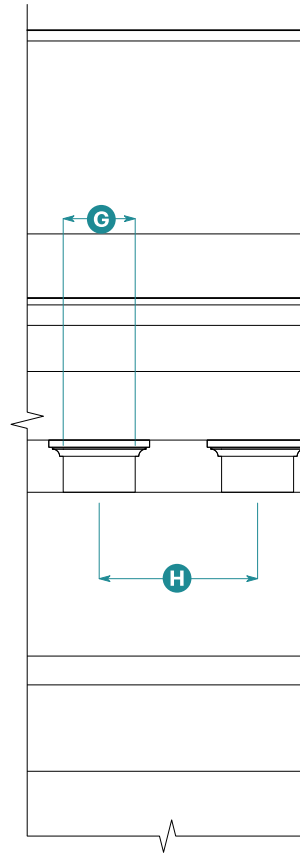
**3. Wall**  
 No wall standards apply to this style. See Subsection 16 (Materials) for materials standards.

**4. Base**  
 Height 1'0" min.; 2'0" max. **A**





Parapet Section



Parapet Elevation

**5. Building Roof**

Form	
Roof Type	Flat

**6. Rake**

Because this style does not allow sloped roofs, rake is not regulated. For wall-roof junction standards, see Subsection 8 (Parapet).

**7. Eave**

Because this style does not allow sloped roofs, eave is not regulated. For wall-roof junction standards, see Subsection 8 (Parapet).

**8. Parapet**

Height		
Overall	5'6" min.	<b>B</b>
Cornice	1'8" min.	<b>C</b>
Fascia		
Overall	3'6" min.	<b>D</b>
Lower Band	1'2" min.	<b>E</b>
Horizontal Projection <sup>1</sup>		
Overall	2'6" min.	<b>F</b>
Continuous cornice required on all street facing facades.		
Required Ornament		
Type	Dentils	
Width	10" min.	<b>G</b>
Spacing	2'0" max. on center	<b>H</b>
Placement	Below cornice at top of fascia	

<sup>1</sup> Horizontal projection includes gutter.

**9. Windows**

**Opening**

Proportion, Height <b>I</b> to Width <b>J</b> <sup>2</sup>	
Ground Floor	2.0 min.
Upper Floor	1.75 min.

Typical Sizes, Width **J** x Height **I**

Ground Floor, Typical	3'0" x 6'6"
Ground Floor, Picture	4'6" x 6'6"
Upper Floor, Typical	3'0" x 5'6"
Upper Floor, Picture	4'6" x 5'6"
Privacy	2'0" x 4'0"

Shape	Square
-------	--------

Operation	Single Hung, Double Hung, Casement
-----------	------------------------------------

**Window**

Glazing Divisions	6 over 9; 6 over 6
-------------------	-----------------------

Frame Width (Frame + Sash)

At Rail	2.5" min. ± 1/4"	<b>K</b>
At Stile	2.5" min. ± 1/4"	<b>L</b>

Molding Widths

Head	2" min.	<b>M</b>
Jamb	2" min.	<b>N</b>

**Window Frame Recess**

Depth	2" min.
-------	---------

**Sill**

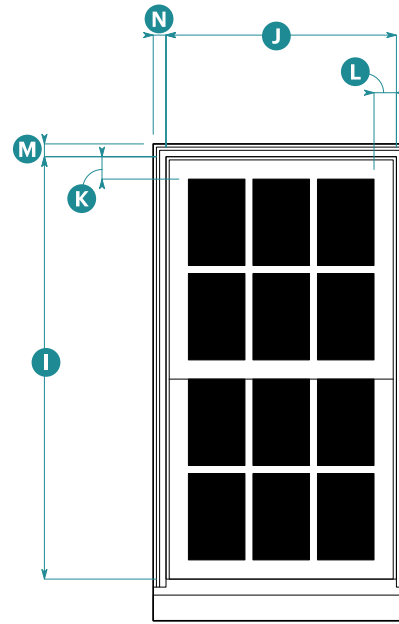
Depth	3" min.
-------	---------

**Pediment**

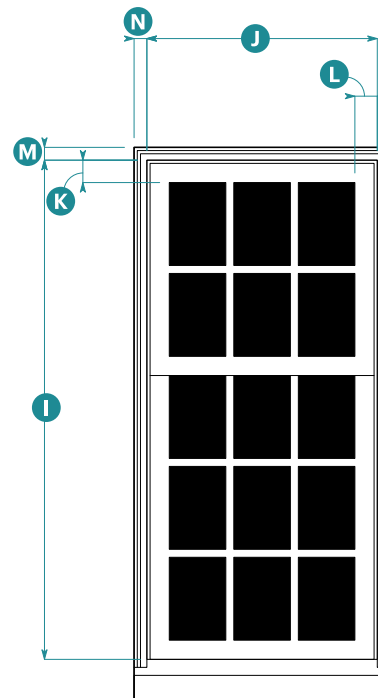
Allowed	Yes
---------	-----

"Typical" refers to a regular recurring window (i.e., size or lite pattern) on a facade.

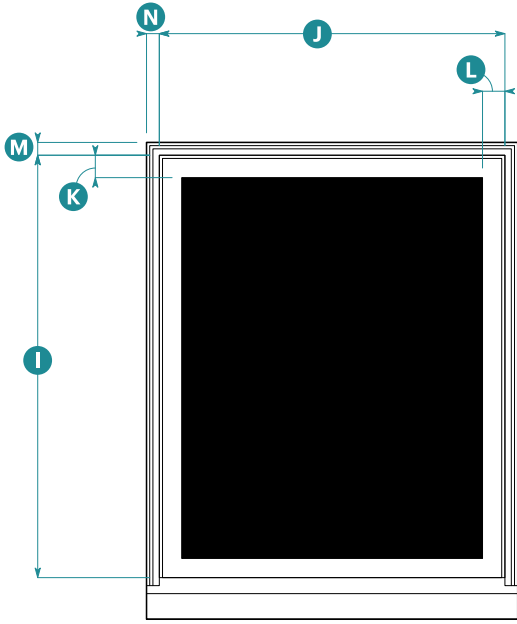
<sup>2</sup>Picture windows shall be wider than typical windows and equal in height to windows on the same floor.



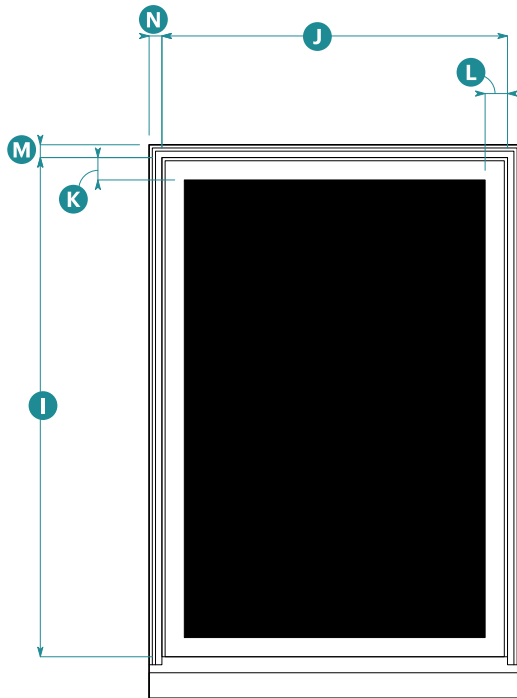
Upper Floor Typical Window Elevation  
6 over 6



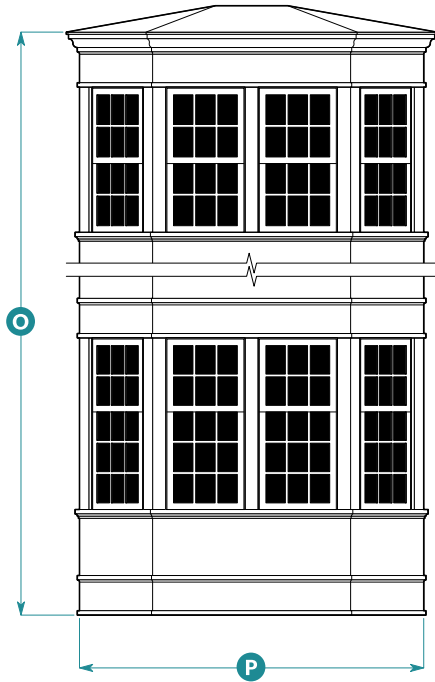
Ground Floor Typical Window Elevation  
6 over 9



*Upper Floor Picture Window Elevation*



*Ground Floor Picture Window Elevation*



**10. Bay Windows**

**Form**

Type	Chamfered
Interior Angle	30 degrees min.; 55 degrees max.
Number of Faces	3 or 5

**Size**

Height		<b>O</b>
On buildings with heights up to 3 stories	2 stories max.	
Width	6'0" min.; 12'0" max.	<b>P</b>
Depth	1'0" min.; 3'0" max.	<b>Q</b>

**Cornice Types**

- Cornice wraps bay.
- Bay stops below building cornice (bay has own cornice).
- Bay returns into building cornice (bay never projects above the building cornice).

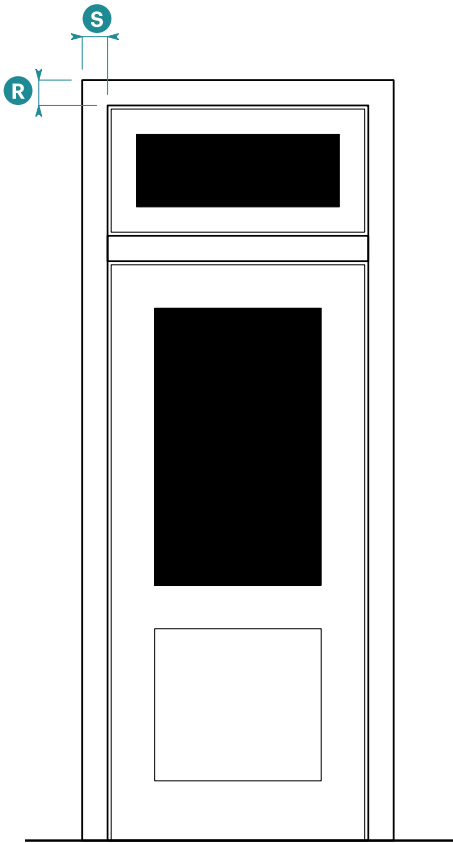
**10. Bay Windows (Continued)**

**Additional Standards**

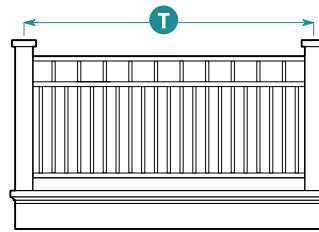
Bay depth not allowed to project beyond cornice depth.  
 Multi-story bay window form shall be vertically continuous.  
 Continuous horizontal articulation on building shall wrap bay form.

**11. Dormers**

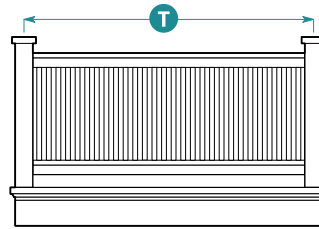
Because this style does not allow sloped roofs, dormers shall not be used.



Entry Door Elevation



Type 1  
Square Guardrail



Type 2  
Decorative Metal Guardrail

Balcony Front Elevation

**12. Entry Doors**

**Door**

Number of Panels 2 min.

**Surround**

Head Width 4" min. R

Jamb Width 4" min. S

**Additional Elements**

Transom Allowed

Pediment Allowed

**13. Balconies**

**Allowed Materials**

**Type 1 - Square Guardrail**

Post, Baluster, Handrail, Metal, composite wood, wood  
Fascia, and Brackets

**Type 2 - Decorative Metal Guardrail**

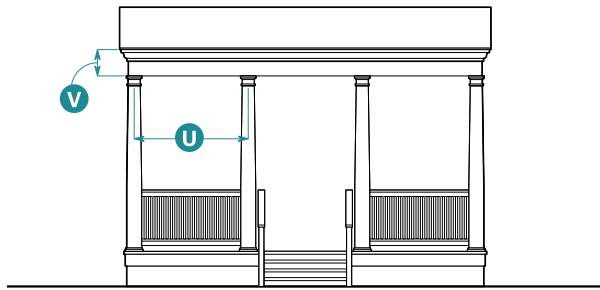
Post, Handrail, Fascia, Metal, composite wood, wood  
and Brackets

Baluster Metal

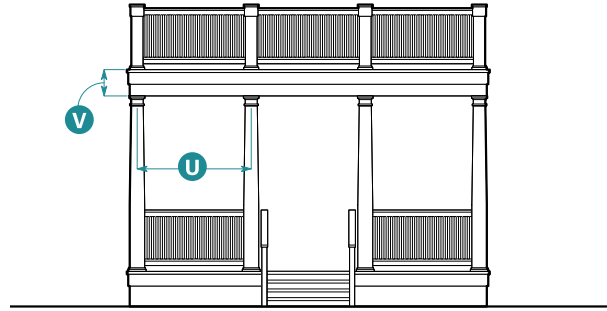
**Size**

Overall Balcony Width 10'0" max.

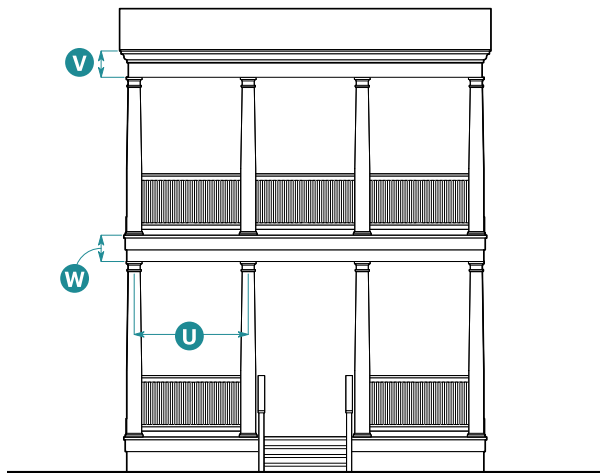
Width Between Posts 3' min. T



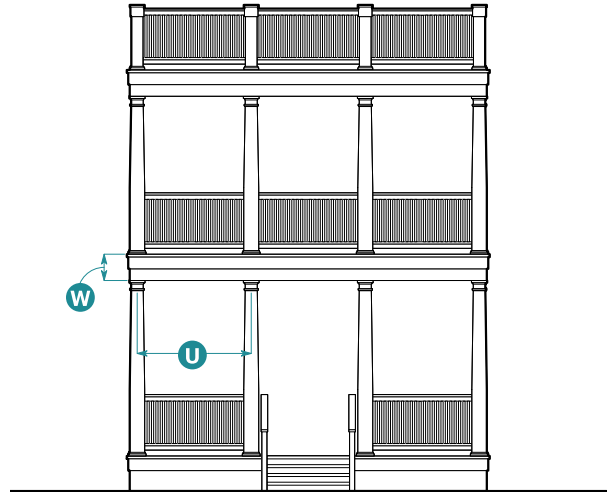
One-Story Porch



One-Story Porch with Deck Above



Two-Story Porch



Two-Story Porch with Deck Above

## 14. Porches

### Columns

Shape Clearly defined capital, base, and shaft; shaft either turned with entasis or square stock with optional detailing

Diameter 8" min.

Spacing 6'6" max. on center **U**

### Entablature

#### Height of Topmost Entablature

Overall 1'6" min. **V**

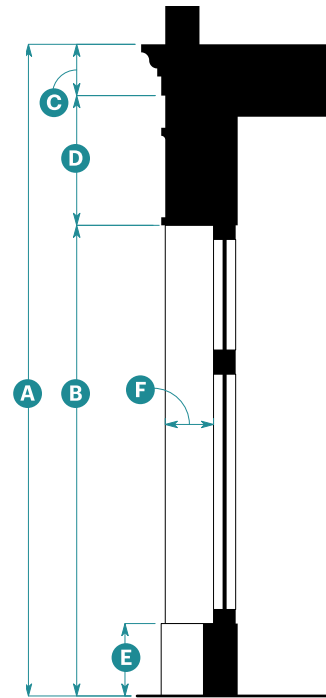
Fascia 10" min.

#### Height of Floor-to-Floor Entablature

Overall 10" min. **W**



Storefront Elevation



Storefront Section

**15. Storefronts**

**Width**

Storefront Module	10'0" min.; 15'0" max.	X
Display Window	3'0" min.; 4'0" max.	Y
Distance Between Storefront Modules	1'6" min.; 2'6" max.	Z

**Height**

Overall	13'0" min.	A
Head Height	10'0" min.	B
Cornice	10" min.	C
Signage Band	1'8" min.	D
Base	1'0" min.; 2'0" max.	E

**Horizontal Recess**

Depth	6" min.; 2'0" max.	F
-------	--------------------	---

Base shall be continuous, unless divided by pilaster, and align with base height of building (if any).

Cornice shall be continuous.



<b>16. Materials</b>	
<b>Element</b>	<b>Allowed Materials</b>
<b>Wall</b>	
Wall Cladding	Brick, stucco
<b>Base</b>	
Base or Foundation	Brick, stone
<b>Windows, Bay Windows, and Entry Doors</b>	
Lintel	Stone, concrete
Entry Door	Wood, aluminum-clad wood, aluminum
Window Frames	Wood, aluminum clad wood, aluminum, fiberglass
Glazing	Clear glass; shall not be tinted, mirrored, or colored
<b>Balconies</b>	
See Subsection 13 (Balconies) for allowed materials.	
<b>Porches</b>	
Columns	Composite wood, wood, cast stone, metal
Railing	Composite wood, wood, metal
<b>Storefronts</b>	
Storefront	Composite wood, wood, metal
Storefront Base	Wood panels, brick, stone tile, fiber cement

22.08.090 Mediterranean



General note: The images above and the descriptions in Subsections 1 and 2 below are intended to provide a brief overview of the architectural style and are descriptive, not regulatory.

**1. Description of Style**

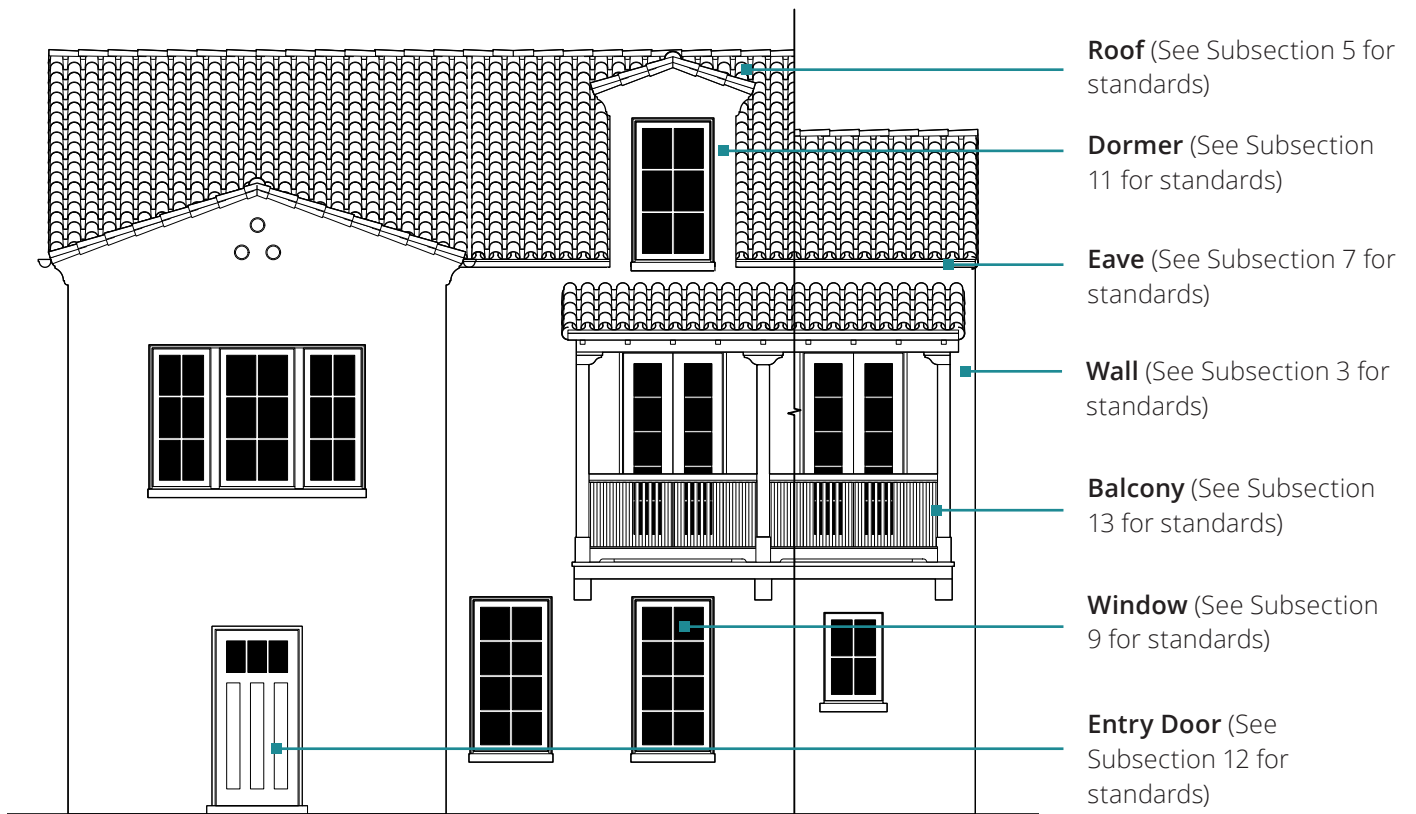
Mediterranean style buildings in Marin County draw from Spanish Colonial, Pueblo, and Spanish Revival influences. These buildings combine austere wall planes with punched, recessed openings for windows.

**2. Typical Characteristics**

- Low-pitched gabled or hipped roofs clad in red tile with open eaves
- Flat, rectilinear wall plane with vertically proportioned punched openings without trim
- Stucco as primary facade material with stucco or wood attached elements

# Elements of Mediterranean Style – Multifamily Prototype

Note: The image below is intended to provide a reference for architectural elements and is illustrative, not regulatory. It is not an exhaustive list of applicable standards.



Prototypical Building Elevation

### 3. Wall

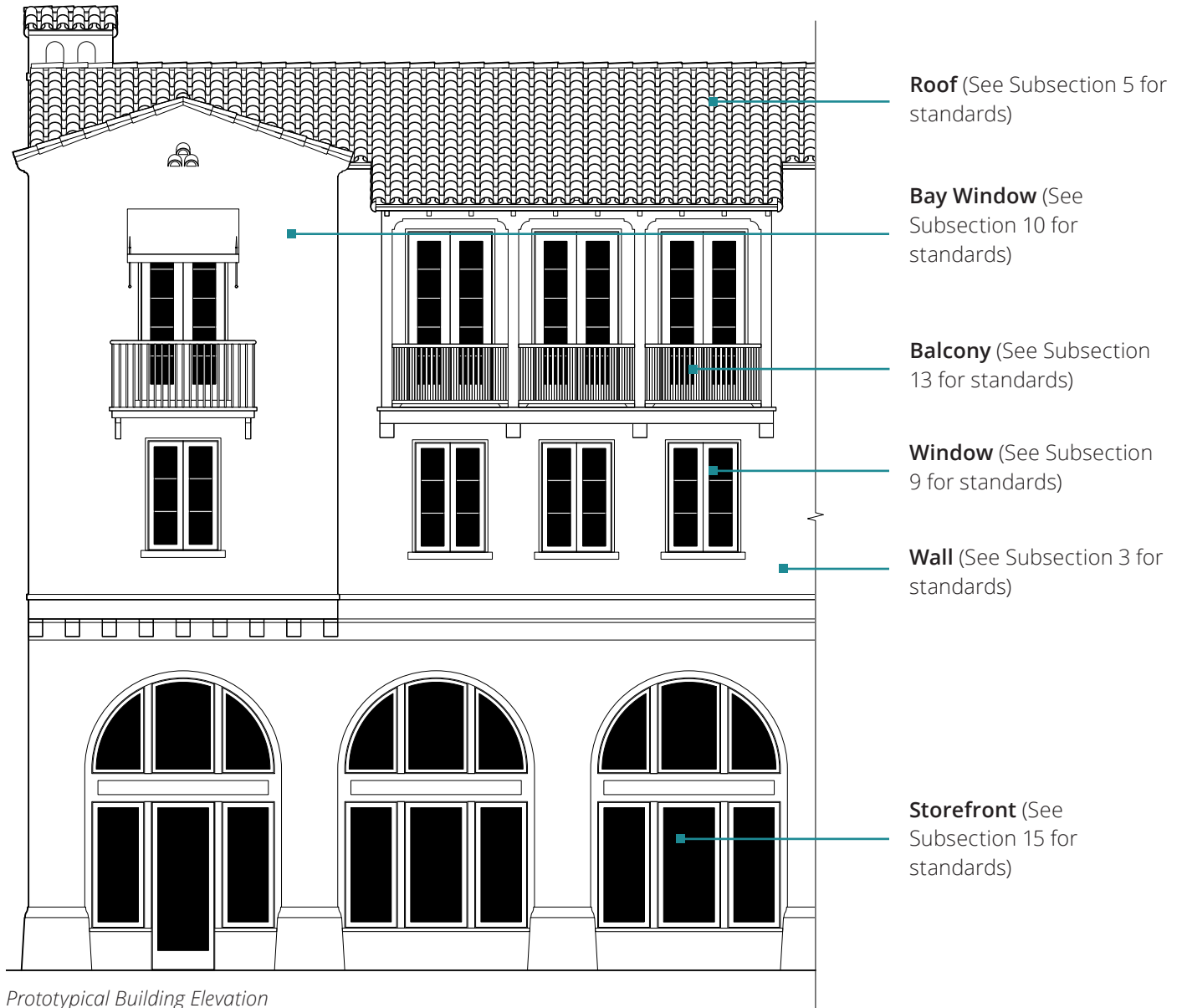
No wall standards apply to this style. See Subsection 16 (Materials) for materials standards.

### 4. Base

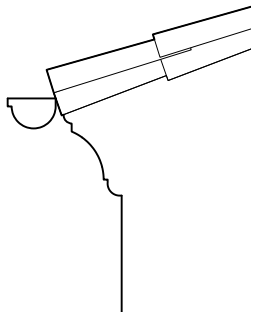
None required

## Elements of Mediterranean Style – Mixed-Use Prototype

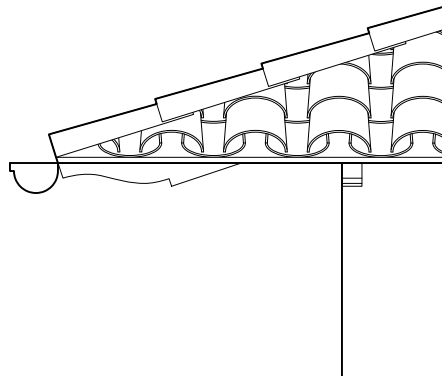
Note: The image below is intended to provide a reference for architectural elements and is illustrative, not regulatory. It is not an exhaustive list of applicable standards.



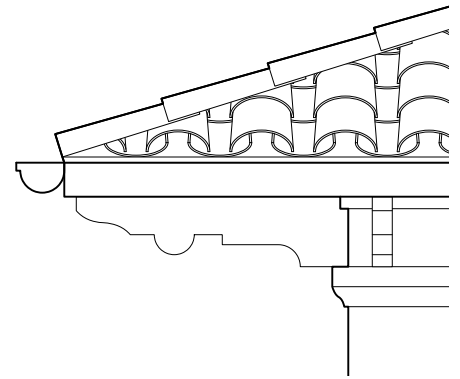
Prototypical Building Elevation



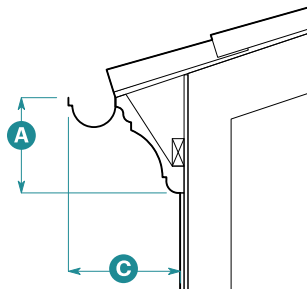
Closed Eave Elevation



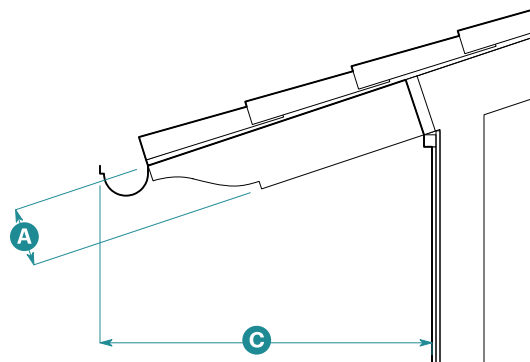
Open Eave Elevation



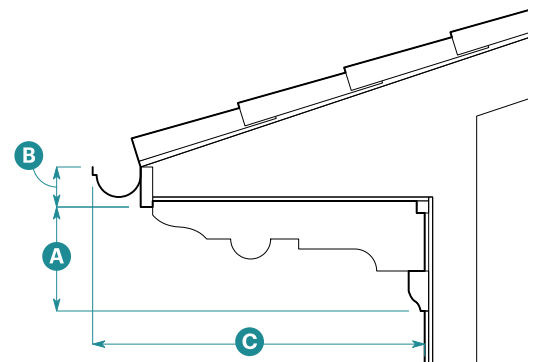
Returned Eave Elevation



Closed Eave Section



Open Eave Section



Returned Eave Section

**5. Building Roof**

Building Roof Standards	Sloped Roof	Flat Roof
<b>Applicable Subsections</b>		
Subsection 6 (Rake)	A	N/A
Subsection 7 (Eave)	A	N/A
Subsection 8 (Parapet)	N/A	A

**Form**

Pitch	4:12 min.; 6:12 max.	N/A
-------	-------------------------	-----

**6. Rake**

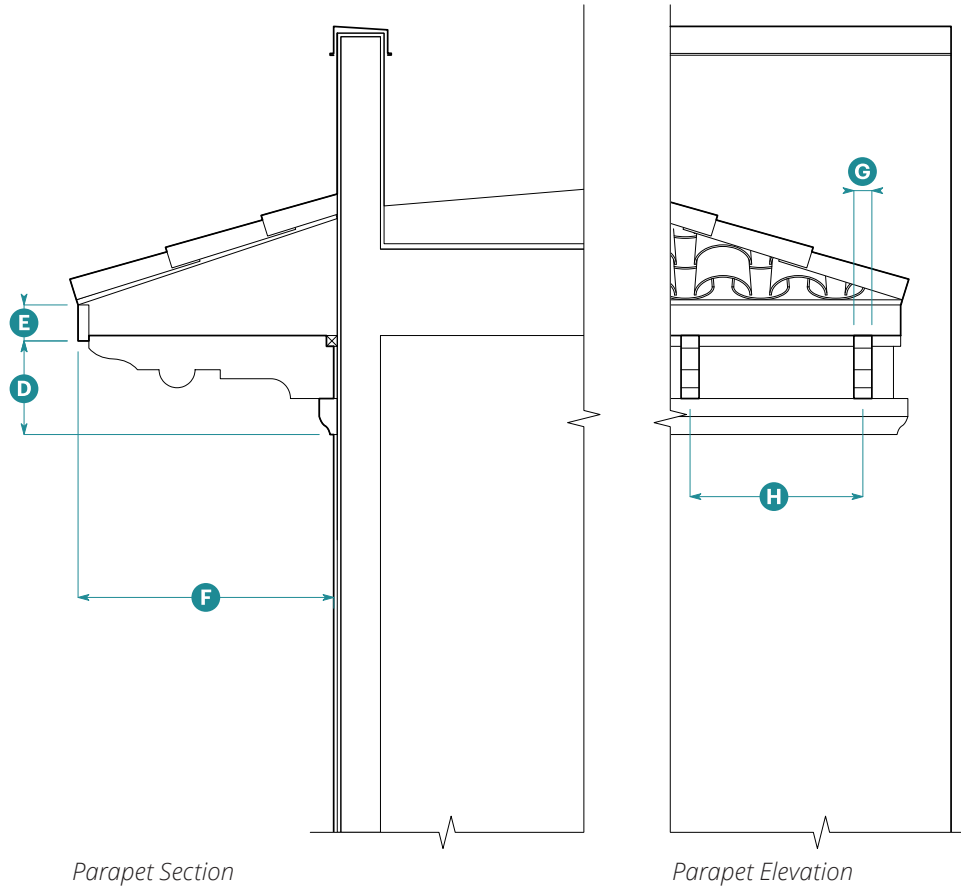
No specialized rake profile

**7. Eave**

Standards	Closed	Open	Returned
<b>Height</b>			
Supporting Element	1'0" min.	8" min.	1'0" min. <b>A</b>
Fascia	None	None	6" min. <b>B</b>
<b>Horizontal Projection<sup>1</sup></b>			
Overall	1'0" min.	3'0" min.	2'6" min. <b>C</b>

<sup>1</sup>Horizontal projection includes gutter.

**Key**                      A = Applicable    N/A = Not Applicable



Parapet Section

Parapet Elevation

**8. Parapet**

**Height**

Supporting Element	1'8" min.	<b>D</b>
--------------------	-----------	----------

Fascia	6" min.	<b>E</b>
--------	---------	----------

**Horizontal Projection<sup>2</sup>**

Overall	2'0" min.	<b>F</b>
---------	-----------	----------

Continuous cornice required on all street facing facades.

**Required Ornament**

Type	Brackets	
------	----------	--

Width	3" min.	<b>G</b>
-------	---------	----------

Spacing	24" max. on center	<b>H</b>
---------	--------------------	----------

Placement	Below fascia	
-----------	--------------	--

<sup>2</sup>Horizontal projection includes gutter.

**9. Windows**

**Opening**

Proportion, Height **I** to Width **J**<sup>3</sup>

Ground Floor	2.0 min.
Upper Floor	1.75 min.
Dormer	See Subsection 11 (Dormers) for standards.

Typical Sizes, Width **J** x Height **I**

Ground Floor, Typical	3'0" x 6'0"
Ground Floor, Ganged	2'4" x 6'0"
Ground Floor, Picture	4'6" x 6'0"
Upper Floor, Typical	3'0" x 5'6"
Upper Floor, Ganged	2'4" x 5'6"
Upper Floor, Picture	4'6" x 5'6"
Privacy	2'0" x 4'0"

Shape	Square, arched
-------	----------------

Operation	Casement
-----------	----------

**Window**

Glazing Divisions	6 parts or 8 parts
-------------------	--------------------

Frame Width (Frame + Sash)

At Rail	2.5" min. ± 1/4"	<b>K</b>
At Stile	2.5" min. ± 1/4"	<b>L</b>

Molding Widths

Head	2" min.	<b>M</b>
Jamb	2" min.	<b>N</b>
Apron	None required	

**Window Frame Recess**

Depth	2" min.
-------	---------

**Sill**

Depth	2" min.
-------	---------

**Pediment**

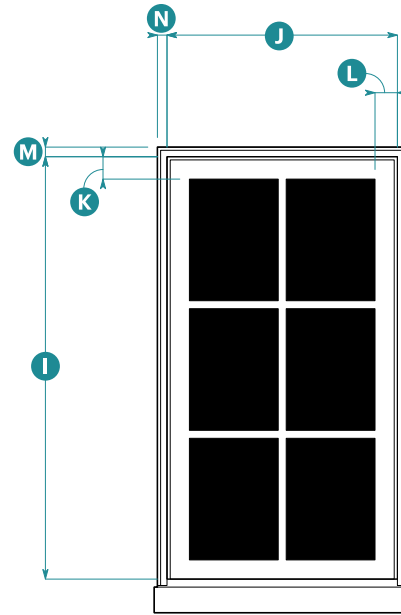
Allowed	No
---------	----

**Mullions**

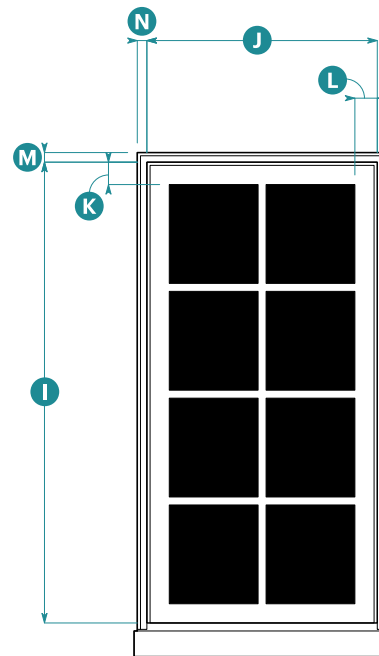
Mullions required between ganged windows.

"Typical" refers to a regular recurring window (i.e., size or lite pattern) on a facade.

<sup>3</sup>Picture windows shall be wider than typical windows and equal in height to windows on the same floor.

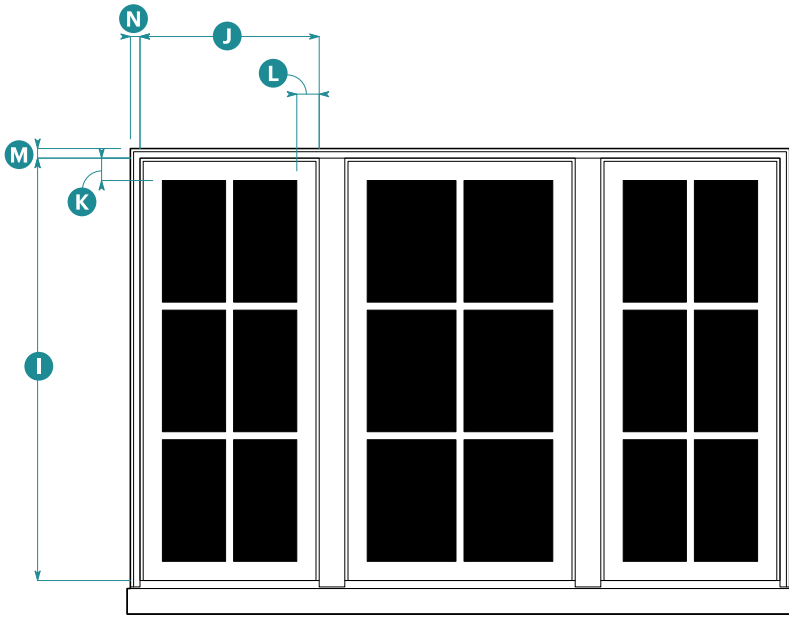


Upper Floor Typical Window Elevation  
6 parts

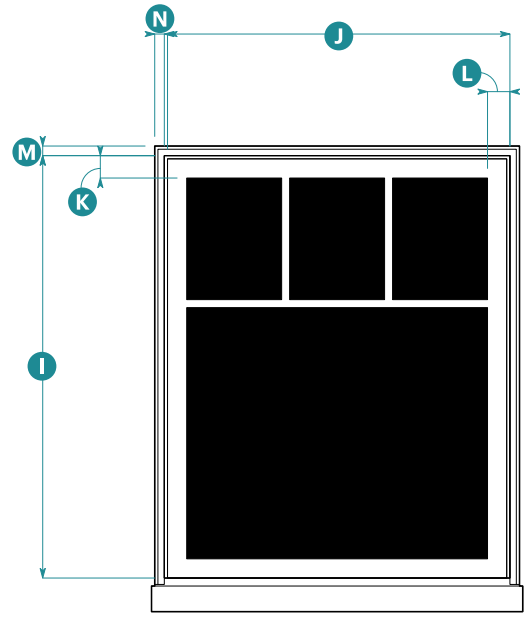


Ground Floor Typical Window Elevation  
8 parts

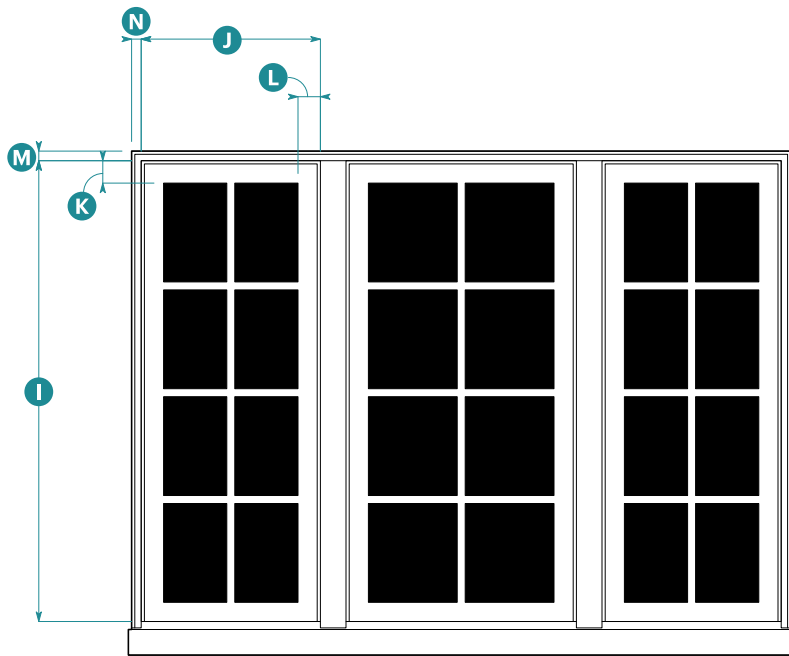




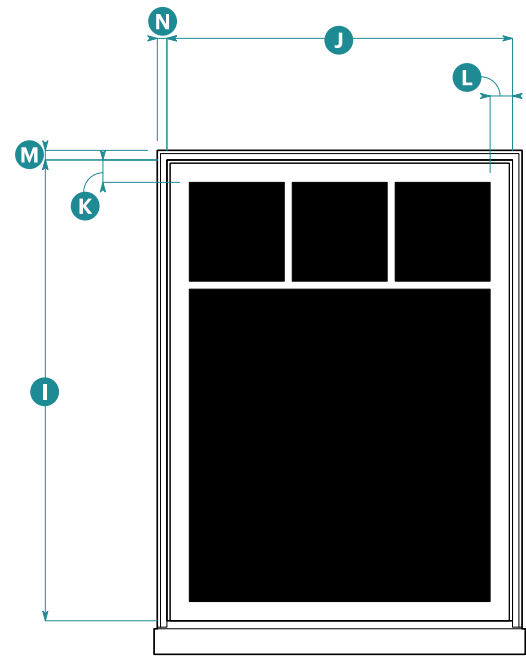
Upper Floor Ganged Window Elevation  
6 parts



Upper Floor Picture Window Elevation



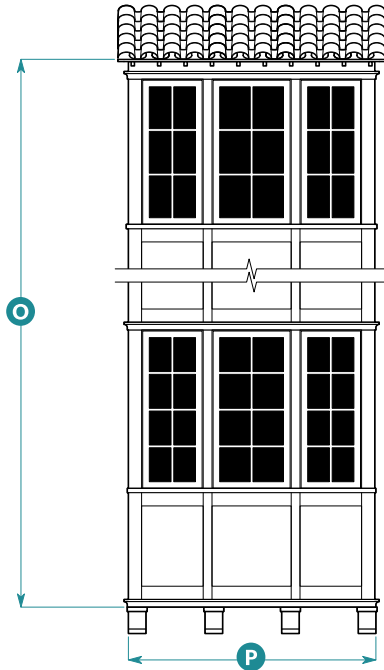
Ground Floor Ganged Window Elevation  
8 parts



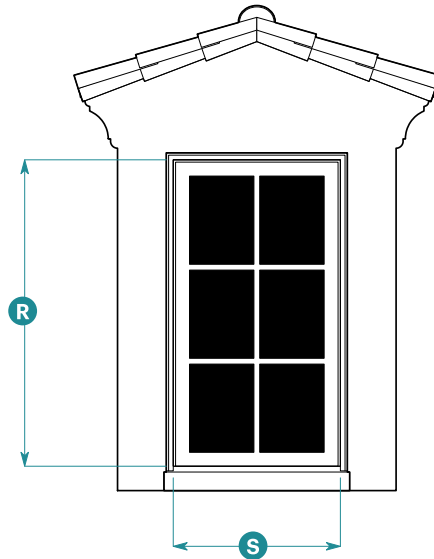
Ground Floor Picture Window Elevation



Bay Window Plan



Bay Window Elevation



Dormer Elevation

**10. Bay Windows**

**Form**

Type Square<sup>4</sup>

**Size**

Height O

On buildings with heights up to 3 stories 2 stories max.

Width P 6'0" min.; 12'0" max.

Depth Q 1'0" min.; 3'0" max.

**Cornice Types**

Building eave wraps bay.

Bay stops below building eave (bay has own cornice).

Bay returns into building eave (bay never projects above the building eave).

<sup>4</sup>Corner bay may be turned on side to be rotated 45 degrees from building corner.

**10. Bay Windows (Continued)**

**Additional Standards**

Bay depth not allowed to project beyond eave depth.

Multi-story bay window form shall be vertically continuous.

Continuous horizontal articulation on building shall wrap bay form.

**11. Dormers**

**Roof Form**

Type Gable

Pitch 4:12 min.; 8:12 max.

**Window**

Proportion, Height 1.75 min.

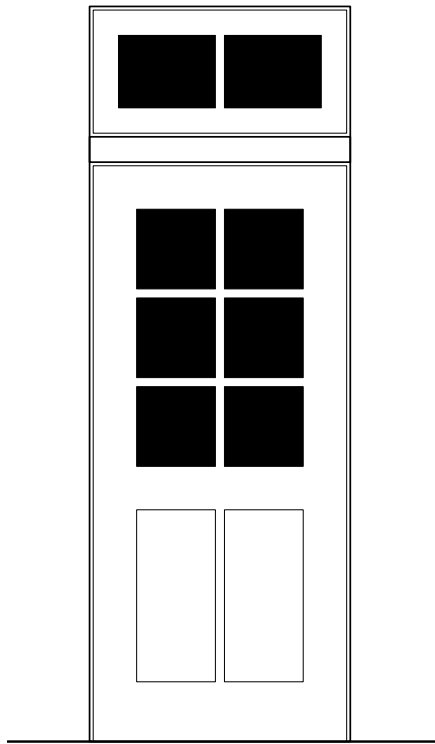
R to Width S

**Pediment**

Allowed No

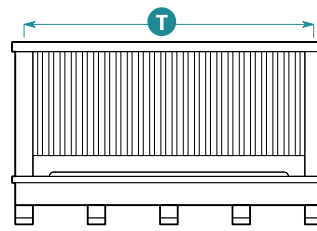
Dormers allowed for buildings with half stories.

See Subsections 6 (Rake), 7 (Eave), and 9 (Windows) for additional standards.

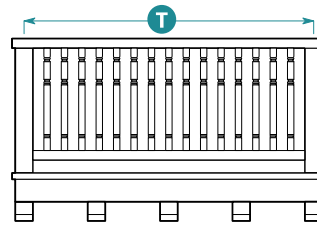


Entry Door Elevation

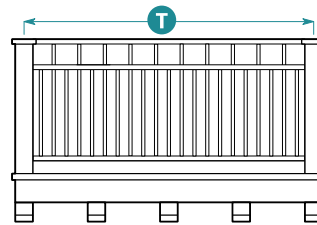
12. Entry Doors	
<b>Door</b>	
Number of Panels	2 min.
<b>Surround</b>	
None required	
<b>Additional Elements</b>	
Transom	Allowed
Pediment	Not Allowed



Type 1  
Square Guardrail



Type 2  
Turned Guardrail

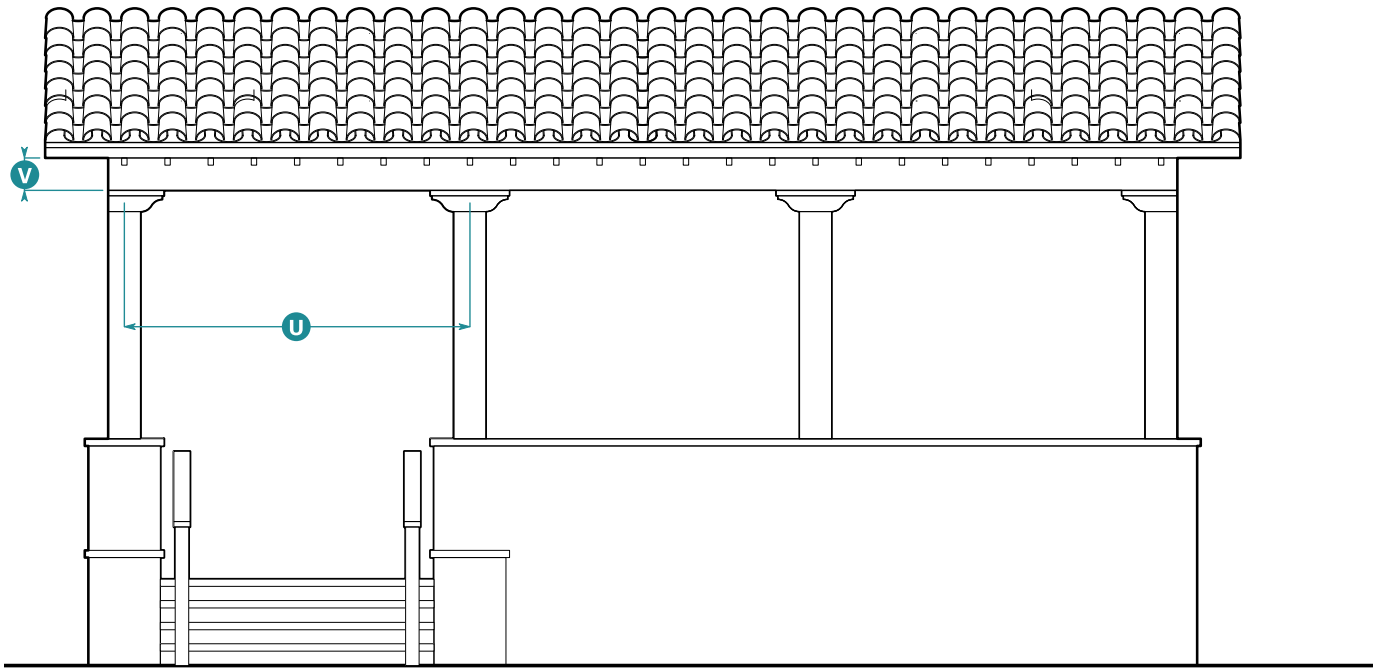


Type 3  
Decorative Metal Guardrail

Balcony Front Elevation

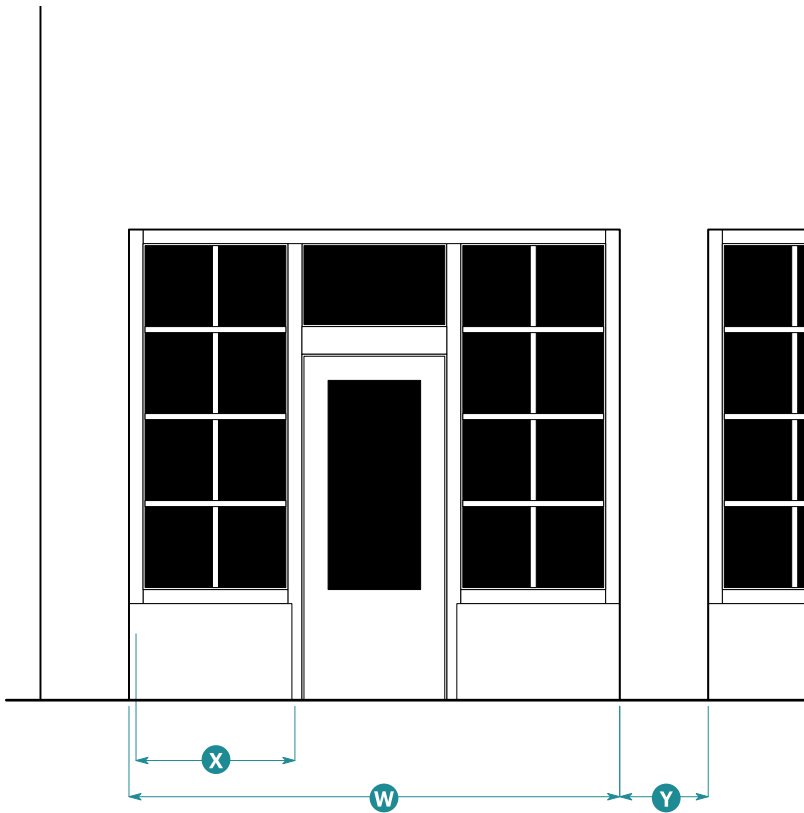
13. Balconies	
<b>Allowed Materials</b>	
<b>Type 1 - Square Guardrail</b>	
Post, Baluster, Handrail, Fascia, and Brackets	Metal, composite wood, wood
<b>Type 2 - Turned Guardrail</b>	
Post, Baluster, Handrail, Fascia, and Brackets	Metal, composite wood, wood
<b>Type 3 - Decorative Metal Guardrail</b>	
Post, Handrail, Fascia, and Brackets	Metal, composite wood, wood
Baluster	Metal
<b>Size</b>	
Overall Balcony Width	10'0" max.
Width Between Posts	3' min.



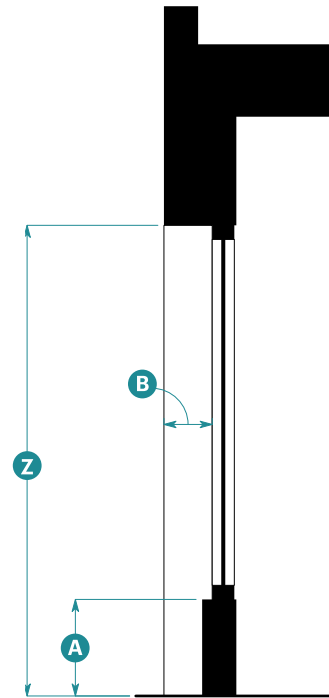


Porch Elevation

14. Porches	
<b>Columns</b>	
Shape	Square or round, with capitals or brackets
Diameter	8" min.
Spacing	9'0" max. on center <span style="float: right;">U</span>
<b>Entablature</b>	
Overall	10" min. <span style="float: right;">V</span>



Storefront Elevation



Storefront Section

**15. Storefronts**

**Width**

Storefront Module	10'0" min.; 15'0" max.	W
Display Window	3'0" min.; 4'0" max.	X
Distance Between Storefront Modules	1'6" min.; 2'6" max.	Y

**Height**

Head Height	11'0" min.	Z
Cornice	None	
Signage Band	None	
Base	1'0" min.; 2'0" max.	A

**Horizontal Recess**

Depth	6" min.; 9" max.	B
-------	------------------	---

Base shall be continuous, unless divided by pilaster, and align with base height of building (if any).

<b>16. Materials</b>	
<b>Element</b>	<b>Allowed Materials</b>
<b>Wall</b>	
Wall Cladding	Stucco
<b>Roof and Roof Elements</b>	
Roofing	Terracotta clay barrel tiles
Rake and Eave	Wood, composite wood, stucco
Cornice	Wood, composite wood, stucco
Brackets	Composite wood, wood, or fiberglass
Gutter	Metal half-round
<b>Windows, Bay Windows, and Entry Doors</b>	
Entry Door	Wood, aluminum, fiberglass, composite
Window Frames	Wood, aluminum-clad wood, aluminum, fiberglass
Sill	Stucco, cast stone
Glazing	Clear glass; shall not be tinted, mirrored, or colored
<b>Balconies</b>	
See Subsection 13 (Balconies) for allowed materials.	
<b>Porches</b>	
Columns	Composite wood, wood, fiberglass, metal
Railing	Wood, wrought iron
<b>Storefronts</b>	
Storefront	Composite wood, wood, metal
Storefront Base	Stucco, tile

# Chapter 9: Specific to Large Sites

---

## Sections:

22.09.010	Purpose
22.09.020	General to Walkable Community Design
22.09.030	Walkable Neighborhood Plan
22.09.040	General to Civic Space

---

## 22.09.010 Purpose

This Chapter establishes standards to create walkable neighborhoods.

1. Development subject to this Chapter is required to create and reinforce walkable neighborhoods with a mix of housing, civic, retail, and service uses within a compact, walkable, and transit-friendly environment.
2. Developments in compliance with this Section shall achieve the following goals:
  - A. Improve the built environment and human habitat;
  - B. Promote development patterns that support safe, effective, and multi-modal transportation options, including auto, pedestrian, bicycle, and transit;
  - C. Reduce vehicle traffic and support transit by providing for a mixture of land uses, highly interconnected block and street network, and compact community form;
  - D. Generate or reinforce neighborhoods with a variety of housing types to serve the needs of a diverse population;
  - E. Promote the health benefits of walkable environments;
  - F. Generate pedestrian-oriented and scaled neighborhoods where the automobile is accommodated but does not dominate the streetscapes;
  - G. Reinforce the unique identity of the City and build upon the local context, climate, and history;
  - H. Realize development based on the patterns of existing walkable neighborhoods; and
  - I. Design that suits specific topographical, environmental, design site layout, and design constraints unique to the design site.

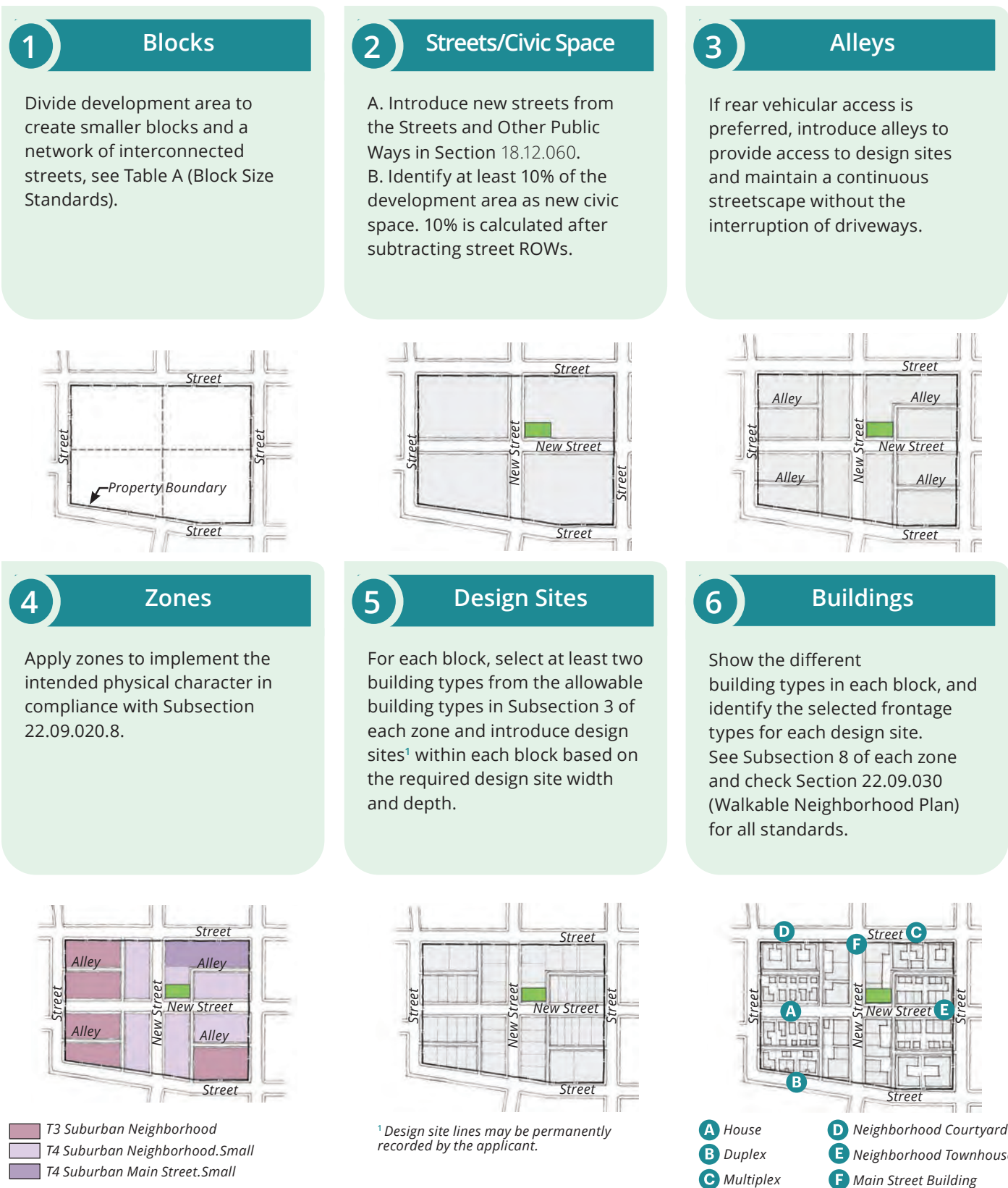


---

## 22.09.020 General to Walkable Community Design

1. Developments of at least two acres or at least 700 feet long or deep shall be designed per the following standards:
  - A. Developments of at least two acres, see Figure 1 [Walkable Neighborhood Plan Design Process Overview for Large Sites (At Least 2 Acres)]
  - B. **Walkable Neighborhood Plan (WNP).** Proposed development is required to include a Walkable Neighborhood Plan (WNP) in compliance with this Subsection that identifies the proposed and existing blocks, civic and open spaces, and streets within 1,500 linear feet of the proposed development. WNP's shall include the information required in Section 22.09.030 (Walkable Neighborhood Plan).
2. **Civic Space Required**
  - A. Civic space shall be provided in compliance with Section 22.09.040 (General to Civic Space).
  - B. A minimum of 10 percent of the total development area, after subtracting street right-of ways, is required.
3. **Streets.** Streets are to be applied to create walkable neighborhoods with redundant routes for vehicular, bicycle, and pedestrian circulation.
  - A. New streets are required to meet the standards in Section 18.12.060 (Streets and Other Public Ways—Minimum Requirements), including maximum slope.
  - B. Required streets, indicated on the Official Zoning Map or Site Development Regulating Plan may be adjusted from their identified location by up to 100 feet in either direction.
  - C. The WNP shall identify the proposed street and block network.
  - D. Streets that pass from one zone to another may transition in their streetscape along the street's edges. For example, while a street within a more intense zone (e.g., T4SMS.S) with retail shops may have wide sidewalks with trees in grates, it may transition to a narrower sidewalk with a planting strip within a less intense zone (e.g., T4SN.S) with lower intensity residential building types.
4. **Alleys**
  - A. Existing alleys may be removed if street access is provided to the design sites on those blocks in compliance with the access standards of the zone.
  - B. Alleys may be added in compliance with Section 18.12.060 (Streets and Other Public Ways—Minimum Requirements) and in compliance with Table A (Block Size Standards).
  - C. Design sites adjoining an alley and/or with a slope greater than six percent may be reduced in depth by up to 10 feet of the required depth. Rear setbacks may be reduced as allowed by Section 22.10.030 (Adjustment to Standards). Front setbacks shall not be reduced.
5. **External Connectivity**
  - A. The arrangement of streets shall provide for the alignment and continuation of existing or proposed streets into adjoining lands where the adjoining lands are undeveloped and intended for future development, or where the adjoining lands are undeveloped and include opportunities for such connections.
  - B. Street rights-of-way shall be extended to or along adjoining property boundaries to provide a roadway connection or street stub for development, in compliance with Table A (Block Size Standards), for each direction (north, south, east, and west) in which development abuts vacant land.

Figure 22.09.020.1: Walkable Neighborhood Plan Design Process Overview for Large Sites (At Least 2 Acres)



- C. Right-of-way stubs shall be identified and include a notation that all stubs are to connect with future streets on adjoining property and be designed to transition in compliance with Section 18.12.060 (Streets and Other Public Ways—Minimum Requirements).
- D. New dead-end streets and cul-de-sacs are not allowed, except when the grade of the new street exceeds 15 percent.

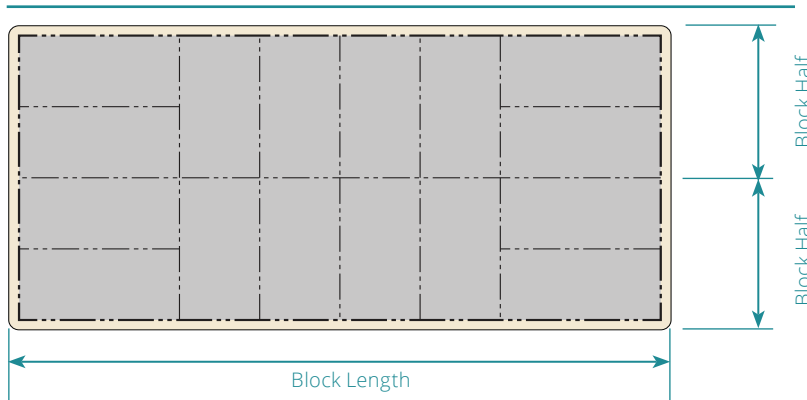
6. **Block Size (New Blocks and Blocks to be Modified)**

- A. Individual block lengths and the total block perimeter shall be in compliance with the standards in Table A (Block Size Standards).
- B. If a block contains multiple zones, the most intense zone is to be used to establish the standards for block size.
- C. Blocks shall be a minimum width to result in two halves of developable design sites in compliance with the design site depth standards for the allowed building types in the zone. A single half is allowed when adjoining an existing half-block.
- D. Blocks may be uniquely shaped in compliance with the standards in Table A (Block Size Standards), and the allowed adjustments in Table 22.10.030.A (Adjustments to Standards for Design Sites Less Than 6% Slopes).

Table 22.09.020.A: Block Size Standards			
Zone	Length	Passage Required <sup>1</sup>	Perimeter Length
T3SN	900' max.	Yes	2,400' max.
T4SN.S	600' max.	Yes	2,000' max.
T4SMS.S	600' max.	Yes	2,000' max.

<sup>1</sup> In compliance with the standards for a Passage in Subsection 22.09.040.11 (Passage)

Figure 22.09.020.2 Block Size



**Key**

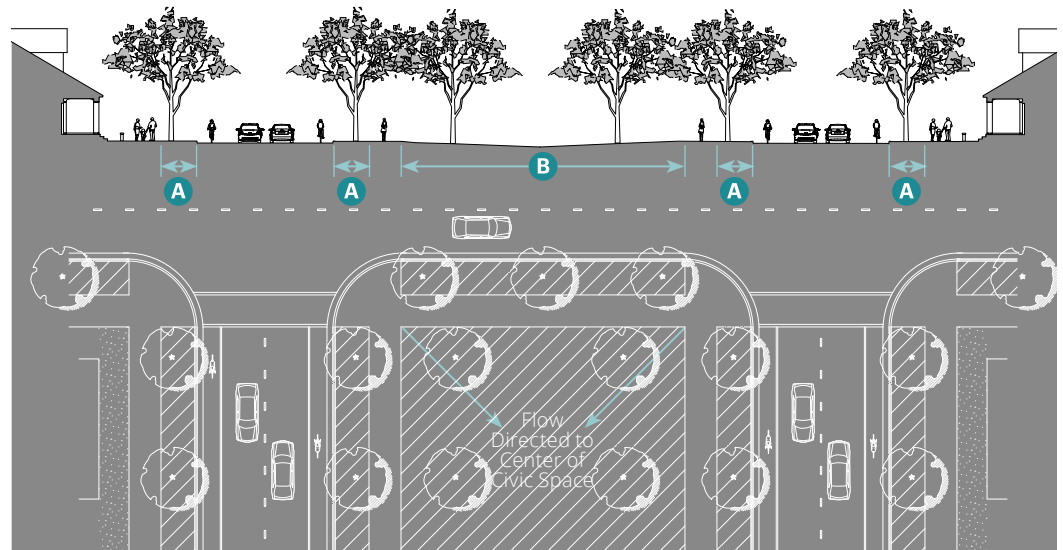
- — — Block Perimeter
- - - - Design Site

7. **Stormwater Management**




A. **Integrated Design**

- (1) Stormwater management is required through a system that is integral to the streetscapes and/or the civic and open space(s) in the development.
- (2) The WNP shall identify the area(s) being proposed for managing stormwater. These areas are required to be a combination of the following:
  - (a) Swale within a planted median;
  - (b) Swale within a continuous tree planter adjacent to the travel lane;
  - (c) Pond or other water body; and/or
  - (d) Areas within an allowed civic space type.
- (3) The area(s) used for stormwater management is to be designed for both seasonal temporary on-site retention of stormwater and as public open space for the neighborhood(s) accessible to the public.
- (4) The stormwater management area(s) may connect with those of adjacent development(s).

**Figure 22.09.020.3 Stormwater Management Diagram**



**Key**

-  Potential Area for Stormwater Management
-  Planted Swale
-  Civic Space Graded to also Accommodate Stormwater

8. **Applying Zones**

- A. **Allocation of Zones.** The WNP shall map the proposed zones on the proposed blocks and any existing blocks in the development in compliance with the following:
  - (1) Sites less than three acres are required to apply one zone, using only the zones established in Chapter 3 (Zones); or
  - (2) Sites greater than three acres and up to 20 acres shall apply at least two zones using only the zones established in Chapter 3 (Zones); or
  - (3) Sites over 20 acres shall apply zones in compliance with the allocation mix standards in Table B (Required Allocation Mix of Zones).
- B. **Organization of Zones.** Zones shall be organized and mapped in a manner that responds appropriately to the various design site conditions. When applying or amending zone boundaries, more intense zones (i.e., T4SMS.S) shall be organized around a neighborhood main street, civic or open space, transit stop, or civic building locations suitable for greater intensities. These areas shall not be located on slopes greater than six percent.
- C. **Transition between Zones.** Transitions between zones shall occur within the block or across alleys along the adjacent prevailing slope.

Table 22.09.020.B: Required Allocation Mix of Zones		
Zone	Minimum % of Land <sup>1</sup>	Maximum % of Land <sup>1</sup>
<b>Walkable Development</b>		
<b>Total to not exceed 100%</b>		
T3SN	None	15%
T4SN.S	10%	40%
T4SMS.S	None	25%
<b>Walkable Development within 1,500 feet of transit stop<sup>2</sup></b>		
<b>Total to not exceed 100%</b>		
T3SN	None	10%
T4SN.S	30%	50%
T4SMS.S	None	30%

<sup>1</sup>Net area after subtracting rights-of-way for streets and open/civic space

<sup>2</sup>A high-frequency transit stop with approximately 15-minutes between arriving buses

---

## 22.09.030 Walkable Neighborhood Plan

### 1. Walkable Neighborhood Plan (WNP) Standards

#### A. **Organization.** Each WNP is required to:

- (1) Identify the zone(s), civic space(s), street and block network, as allowed to be adjusted by Table 22.10.030.A (Adjustments to Standards for Design Sites Less Than 6% Slopes); and
- (2) Be in compliance with the design standards of Section 22.09.020 (General to Walkable Community Design).

### 2. Required Content

#### A. **General.** Each WNP shall include the following information:

- (1) Boundaries of the proposed development;
- (2) Existing and proposed blocks within 1,500 linear feet of the development boundaries;
- (3) Open space not to be developed (if any);
- (4) Civic space, in compliance with Section 22.09.040 (General to Civic Space); and
- (5) Mapping of proposed zones in compliance with Subsection 22.09.020.8.

#### B. **Illustrative Site Plan**

- (1) The proposed physical character of the WNP shall be identified on an Illustrative Plan showing, in plan view, the proposed building types and private frontage types on each block and the proposed public frontage types showing proposed trees and landscaping along streets and in civic space types.
- (2) As individual needs of a development may change over time, the building types specified in the WNP may be substituted with other building types allowed by the zone in compliance with the zone standards.

### 3. Required Mix of Building Types and Private Frontage Types

- A. The WNP shall maintain a mix of at least two different building types and two different private frontage types within each block, using only the types allowed in the zone(s).
- B. The WNP shall maintain a mix of at least two different architectural styles within each block.
- C. The WNP shall show dimensioned block depths for both halves of each block to demonstrate compliance with the minimum design site depth required for the building types in each zone.
- D. The applicant may choose to show the shortest minimum design site depth allowed in each zone with an acknowledgement that the selected depth may not accommodate the full range of building types allowed by the zone.

---

## 22.09.040 General to Civic Space

1. The WNP shall identify open spaces and civic space types in compliance with the following standards and the standards of Table A (Civic Space Types Overview).
2. When hillsides are within the development, the hillside ridge(s) shall be the location for civic and open space.
3. Required civic and open space identified on the Official Zoning Map may be adjusted from its identified location by up to 100 feet in any direction.
4. Public access and visibility is required along public parks, natural open spaces, and civic uses, including creeks and drainages and stormwater management areas, and shall be fronted by:
  - A. Single-loaded frontage streets (those with development on one side and open space on the other);
  - B. Bike and pedestrian paths; or
  - C. Other methods of frontage that provide similar access and visibility to the open space allowed in the zone. Such access may be provided through public easements or other similar methods.
5. **Amount of Civic Space Required.** As required by Subsection 22.09.020.2, development design sites are required to set aside a minimum area of the design site as civic space. One or more civic spaces may be used to meet the required area.
6. **Building Frontage Along or Adjacent to a Civic Space.** The facades on building design sites attached to or across a street from a civic space shall be designed as a "front" on to the civic space, in compliance with Subsection 5 and Subsection 8 of the zone.
7. **Civic Space Types Overview.** This Subsection identifies the allowed civic space types and standards for improvements to existing civic spaces and for construction of new civic spaces. For each civic space type, Subsection 1 and Subsection 3 are regulatory, and Subsection 2 and Subsection 4 are non-regulatory. Allowed civic space types are identified in Table A (Civic Space Types Overview).



**Table 22.09.040.A: Civic Space Types Overview**

		Zones		
		T3	T4	
	Specific Standards	SN	SN.S	SMS.S
Green	22.09.040.8	P	P	X
Plaza	22.09.040.9	X	X	P
Community Garden	22.09.040.10	P	P	P
Passage	22.09.040.11	P	P	P

---

**Key**            P = Allowed            X = Not Allowed

8. Green



**1. Description**

A large space available for unstructured and limited amounts of structured recreation.

**2. General Character**

Formal or informal with integral stormwater management capacity

Primarily planted areas with paths to and between recreation areas and civic buildings

Spatially defined by tree-lined streets and adjacent buildings

**3. Size and Location**

Size 300' x 300' min.

Street required on at least one side of the Green.

Facades on design sites attached to or across a street shall "front" on to the Green.

**4. Typical Uses**

Unstructured passive and active recreation

Civic uses

Temporary commercial uses

9. Plaza



**1. Description**

A community-wide focal point primarily for civic purposes and commercial activities.

**2. General Character**

Formal, urban

Hardscaped and planted areas in formal patterns

Spatially defined by buildings and tree-lined streets

**3. Size and Location**

Size 50' x 50' min.

Street required one of the Plaza's sides.

Facades on design sites attached to or across a street shall "front" on to the Plaza.

**4. Typical Uses**

Civic uses

Commercial uses in support of civic uses

Passive recreation

Accessory Uses < 1,500 gsf



10. Community Garden



**1. Description**

A small-scale space designed as a grouping of garden plots available for small-scale cultivation. Community gardens may be fenced and may include a small accessory structure for storage. Community Gardens may be included within all other civic space types except Playgrounds.

**2. General Character**

- Informal or Formal, urban
- Combination of planted areas and hardscape
- Spatially defined by building frontages and adjacent street trees
- Walkways along edges or across space

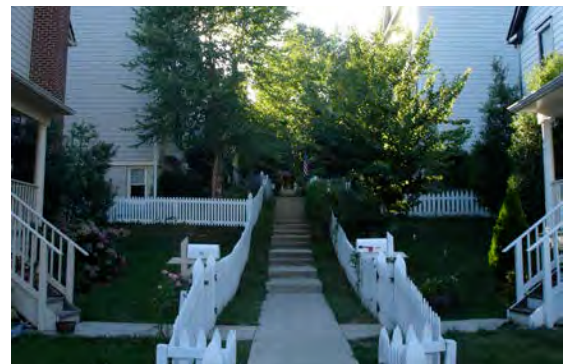
**3. Size and Location**

Size No minimum; within any design site as allowed by the zone

**4. Typical Uses**

- Food production
- Passive recreation

11. Passage



**1. Description**

A pedestrian pathway that extends from the public sidewalk into a civic space and/or across the block to another public sidewalk. The pathway is lined by non-residential shopfronts and/or residential ground floors and pedestrian entries as required by the zone.

**2. General Character**

- Formal, urban
- No accessory structure(s)
- Primarily hardscape with landscape accents
- Spatially defined by building frontages
- Trees and shrubs in containers and/or planters

**3. Size and Location**

- Size 20' min. clear width between or through buildings
- Ground floor facades shall be in compliance with facade zone in Subsection 5 and frontages allowed in Subsection 8 of the zone.
- Dooryards, porches, patios, and sidewalk dining shall not encroach into the minimum required width.

**4. Typical Uses**

- Civic and commercial activity as allowed by the zone
- Ground floor residential as allowed by the zone

*This page intentionally left blank*

# Chapter 10: Administration

---

## Sections:

22.10.010	Purpose
22.10.020	Procedures
22.10.030	Adjustments to Standards

---

## 22.10.010 Purpose

This Chapter is intended to establish procedures for applications eligible for streamlined review consistent with State law (i.e., Senate Bill 35) and for reviewing applications under the Housing Accountability Act. The City is responding to State mandates and including application procedures in the FBC that are compliant with State law but reflect the unique conditions and procedures within the City. The intent of Senate Bill 35 and the Housing Accountability Act is to facilitate and expedite the construction of housing through the application of objective standards and, with Senate Bill 35, ministerial and streamlined approval procedures. These procedures shall be used in conjunction with the objective standards contained in this FBC as applicable.

---

## 22.10.020 Procedures

1. **Procedures for Applications Filed Under** Senate Bill 35
  - A. **Applicability**
    - (1) This Section applies to housing development projects applying for approval under Government Code §65913.4 and replaces the City's procedures for reviewing discretionary applications.
    - (2) This Section shall remain in effect for the same period as Senate Bill 35 provisions contained in Government Code §65913.4. Unless Senate Bill 35 provisions are extended by the State Legislature, this Section shall remain in effect only until January 1, 2026, and as of that date is repealed.
    - (3) The California Environmental Quality Act (CEQA) does not apply to projects eligible under Senate Bill 35.
    - (4) The Department of Housing and Community Development is charged with developing guidelines for implementing Senate Bill 35. These procedures may change if required by changes in those guidelines or in Government Code §65913.4.



- B. **Definitions.** Terms defined in Government Code §65913.4 shall apply to this Section and shall control in the event of a conflict between definitions in this FBC and definitions in Government Code §65913.4.
- C. **Application Filing**
- (1) **Preliminary Application Filing.** An applicant shall file a notice of intent to submit a Senate Bill 35 application in the form of a preliminary application consistent with Government Code §65941.1.
- (a) **Form.** A preliminary application shall be filed on a form provided by the City with the required fee. If the City has not prepared a form, a preliminary application shall be filed on the standardized form adopted by the California Department of Housing and Community Development.
- (b) **Timeline.** Within 180 calendar days after submitting a preliminary application, an applicant shall submit a full Senate Bill 35 application, provided scoping consultation has concluded consistent with Subsection (c), below.
- (c) **Scoping Consultation**
- i. Upon receipt of the preliminary application, the City shall contact the Native American Heritage Commission for assistance in identifying any California Native American tribe that should be noticed. The City shall provide a formal notice of the applicant's intent to submit a full application to each required California Native American tribe within 30 days of preliminary application submittal. The formal notice shall be consistent with Government Code §65913.4(b).
- ii. If, within 30 days of receipt of the formal notice, any California Native American tribe that was formally noticed accepts the invitation to engage in scoping consultation, the City shall commence scoping consultation within 30 days of receiving that response.
- iii. Scoping consultation shall be conducted consistent with Government Code §65913.4(b). If, after scoping consultation is concluded, a development is not eligible for Senate Bill 35 streamlining, the City shall provide written documentation as required by Government Code §65913.4(b) to the applicant and any California Native American tribe that is a party to that scoping consultation.
- (2) **Full Application.** If the development remains eligible to apply under Senate Bill 35 after scoping consultation consistent with Government Code §65913.4(b) has concluded, an applicant may file a full Senate Bill 35 application on a form provided by the City with the required fee.
- D. **Completeness Review.** The City shall review an application for compliance consistent with Subsection 1.E; there shall be no separate or additional timeframe for completeness review. Only the items necessary to determine compliance with the provisions contained in Government Code §65913.4(a) shall be required.

## E. Compliance Review

- (1) **Scope of Review.** The Planning Commission's scope of review is limited to all of the provisions contained in Government Code §65913.4(a) and the objective standards in effect at the time of preliminary application submittal.
- (2) **Review Timeframes and Review Authority**
  - (a) **Consistency Review.** The Director shall determine if the application complies with all of the provisions contained in Government Code §65913.4(a) and applicable objective standards within the following timeframes:
    - i. Within 60 calendar days of application submittal for applications that include 150 or fewer housing units.
    - ii. Within 90 calendar days of application submittal for applications that include 151 or more housing units.
  - (b) **Design Review or Public Oversight.** Any design review or public oversight (i.e., Planning Commission review) to determine if the application complies with all of the provisions contained in Government Code §65913.4(a) and applicable objective standards shall occur within the following timeframes:
    - i. Within 90 calendar days of application submittal for applications that include 150 or fewer housing units.
    - ii. Within 180 calendar days of application submittal for applications that include 151 or more housing units.
- (3) **Compliance Determination**
  - (a) **Compliant Application.** If the application complies with all of the provisions contained in Government Code §65913.4(a) and all applicable objective standards, the City shall complete any design review or public oversight and any subdivision approval within the timeframes listed in Subsection 1.E. Only objective design and subdivision standards may be applied. See Subsection 1.F.
  - (b) **Non-Compliant Application.** If the application does not comply with all of the provisions contained in Government Code §65913.4(a) and all applicable objective standards, the Planning Commission shall make the following determination:
    - i. If the application does not comply with all of the provisions contained in Government Code §65913.4(a) and all applicable objective standards, the Planning Commission shall provide the applicant with written documentation of which standards the development conflicts with and an explanation of the reasons the development conflicts with each standard.
    - ii. Resubmitted Application. If the project was found to be non-compliant, the applicant may resubmit the application for Senate Bill 35 streamlining, and the City shall review it for compliance with all of the provisions contained in Government Code §65913.4(a) and all applicable objective standards subject to the same timelines in Subsection (2) above.
    - iii. Project Ineligible. If the project is ineligible for Senate Bill 35 streamlined processing, the applicant may elect to submit an application for the applicable discretionary approval.

**F. Decision on Project**

- (1) **Project Approval and Findings.** The Planning Commission shall approve the application if the Planning Commission finds that the proposed development is compliant with all of the provisions contained in Government Code §65913.4(a) and all applicable objective standards, including objective subdivision standards.
- (2) **Conditions of Approval.** The Planning Commission may impose conditions of approval provided those conditions of approval are objective and broadly applicable to development within the City.

**G. Post-decision Procedures**

- (1) **Subsequent Permits.** Any necessary subsequent permits shall be issued on a ministerial basis subject to applicable objective standards. If a public improvement is necessary to implement a development subject to this Section, and that public improvement is located on land owned by the City, the Planning Commission shall process any approvals needed as required by Government Code §65913.4(h)(3).
- (2) **Post-Approval Modifications**
  - (a) **Post-Approval Modification Request.** An applicant or the City may request a modification to an approved development if that request is made prior to the issuance of the final building permit.
  - (b) **Applicability of Objective Standards to Modifications.** The Planning Commission shall only apply objective standards in effect when the original application was submitted, except that objective standards adopted after the date of original submittal may be applied in any of the following instances:
    - i. The total number of residential units or total square footage of construction changes by 15 percent or more; or
    - ii. The total number of residential units or total square footage of construction changes by five percent or more, and it is necessary to subject the development to an objective standard beyond those in effect when the application was submitted in order to mitigate or avoid a specific adverse impact upon public health or safety, for which there is no feasible alternative method to satisfactorily mitigate or avoid.
    - iii. Objective building standards contained in Title 24 may be applied to all modifications.
  - (c) **Post-Approval Modification Review Timeframe and Decision.** The Planning Commission shall determine if the modification is consistent with objective planning standards and issue a decision on the applicant's modification request within 60 days after submittal unless design review is required, in which case a decision shall be made within 90 days.
- (3) **Expiration.** An application approved consistent with this Section shall remain valid for three years; however, an application approval shall not expire if the development includes public investment in housing affordability, beyond tax credits, where 50 percent of the units are affordable to households making at or below 80 percent of the area median income consistent with Government Code §65913.4(f).
- (4) **Extension.** At the discretion of the Planning Commission, a one-year extension may be granted consistent with Government Code §65913.4(f)(3).

*This page intentionally left blank*

2. **Procedures for applications filed consistent with the** Housing Accountability Act
- A. **Applicability**
- (1) This Section applies to housing development projects as defined by Government Code §65589.5(h)(2).
  - (2) This Section shall remain in effect for the same period as provisions contained in the Government Code §65589.5 (Housing Accountability Act). Any provisions that are not extended by the State Legislature shall be repealed as of the date those provisions in the Housing Accountability Act are deemed null and void.
- B. **Definitions.** Terms defined in Government Code §65589.5 shall apply to this Section and shall control in the event of a conflict between definitions in this FBC and definitions in Government Code §65589.5.
- C. **Application Filing**
- (1) **Preliminary Application Filing (Optional).** An applicant may file a preliminary application consistent with Government Code §65941.1.
    - (a) A preliminary application shall be filed on a form provided by the City with the required fee. If the City has not prepared a form, a preliminary application shall be filed on the standardized form adopted by the California Department of Housing and Community Development.
    - (b) Within 180 calendar days after submitting a preliminary application, an applicant shall submit a full application for the housing development.
  - (2) **Full Application.** An applicant may file a full application for a housing development without filing a preliminary application. The full application shall be filed on a form provided by the City with the required fee.
- D. **Conflicting Procedures.** This Section provides additional procedures that shall be followed for applicable projects. If conflicts occur between the City's procedures and the procedures of this Section, this Section shall control.

**E. Completeness Review**

- (1) **Preliminary Application.** If a preliminary application is filed, the preliminary application shall be deemed complete when the preliminary application containing all of the information listed in the preliminary application form is submitted. If all listed information is not provided, the City shall request the missing information from the applicant.
- (2) **Full Application**
  - (a) Once a full application is submitted, the City shall inform the applicant in writing within 30 calendar days of submittal or resubmittal that the application is complete or incomplete and the additional information required consistent with Government Code §65943. Only information requested in the City's application forms can be requested. If the City does not provide written notification within this timeframe, the application shall be deemed complete. The City shall review each resubmittal within the 30-day period and cannot request information that was not listed in the first incompleteness letter.
  - (b) If an applicant receives written notification that the application is incomplete, and a preliminary application was submitted for the housing development, the applicant shall submit the information needed to complete the application within 90 calendar days of receiving the written notification of incompleteness. If the applicant does not submit this information within this timeframe, the preliminary application shall expire and have no further force or effect.
  - (c) If a second determination of incompleteness is provided, the applicant shall be able to appeal the decision to the City Council. The City shall make a decision on the appeal no later than 60 calendar days after receipt of the applicant's written appeal. The initial appeal may be to the Planning Commission, but in that case the City Council shall still make a decision within 60 days. If the decision on the appeal is not made within this timeframe, the application shall be deemed complete.

## F. Compliance Review

### (1) Scope of Review

- (a) **Housing Development with a Preliminary Application Submittal.** A housing development for which a preliminary application was submitted shall only be subject to the ordinances, policies, and standards adopted and in effect when the preliminary application is submitted, except in the following circumstances:
- i. A fee, charge, or other monetary exaction increase resulting from an automatic annual adjustment based on an independently published cost index that is referenced in the ordinance or resolution establishing the fee or monetary exaction.
  - ii. A preponderance of the evidence in the record establishes that subjecting the housing development to an ordinance, policy, or standard beyond those in effect when the preliminary application was submitted is necessary to mitigate or avoid a specific, adverse impact upon the public health or safety, and there is no feasible alternative method to satisfactorily mitigate or avoid the adverse impact.
  - iii. Subjecting the housing development to an ordinance, policy, standard, or any other measure, beyond those in effect when the preliminary application was submitted is necessary to avoid or substantially lessen an impact consistent with CEQA.
  - iv. The housing development has not commenced construction within 2.5 years following the date of the housing development's final approval (as defined in Government Code §65589.5(o)(1)(D)).
  - v. The number of residential units or square footage of construction proposed changes by 20 percent or more, exclusive of any increase resulting from a density bonus, incentive, concession, waiver, or similar provision.
- (b) **Housing Development without a Preliminary Application Submittal.** A housing development shall be subject to objective standards in effect when the application was deemed complete.



(2) **Review Timeframes**

- (a) Applications for housing development containing 150 or fewer units shall be reviewed for compliance with applicable objective standards within 30 calendar days of being deemed complete.
- (b) Applications for housing development containing more than 150 units shall be reviewed for compliance with applicable objective standards within 60 calendar days of being deemed complete.

(3) **Review Authority.** The Review Authority shall be the Planning Commission consistent with the City's procedures for the full application; however, if the Director is not the Review Authority, the Director may serve as the Review Authority, if necessary, to comply with Review Timelines described in Subsection 2.F.

(4) **Compliance Determination**

- (a) The Planning Commission shall identify the specific standard(s) that the project does not comply with and provide an explanation of the reason(s) why the housing development is considered to be inconsistent or non-compliant with identified provisions and shall provide the written determination to the applicant.
- (b) A housing development is considered in compliance with this FBC, and shall not require an amendment to the zoning map, if the housing development complies with objective General Plan standards but the zoning for the housing development site is inconsistent with the General Plan.

(5) **Limited Hearings/Meetings.** If a housing development complies with applicable objective standards, the City shall not conduct more than five public hearings (including continuances), workshops, or similar meetings after the full application is complete in connection with the approval of the housing development consistent with Government Code §65905.5. Meetings required by CEQA are exempt from the limit.

## G. Findings and Decision

### (1) Findings

- (a) If the proposed housing development complies with applicable objective General Plan, zoning, and subdivision standards and criteria, including design review standards, the Planning Commission may only deny the housing development or conditionally approve the housing development at a lower density if the Planning Commission makes written findings supported by a preponderance of the evidence in the record that:
  - i. The housing development would have a specific, adverse impact upon the public health or safety unless the housing development is denied or conditionally approved at a lower density. A "specific, adverse impact" means a "significant, quantifiable, direct, and unavoidable impact, based on identified written public health or safety standards, policies, or conditions as they existed on the date that the project was deemed complete"; and
  - ii. There is no feasible method to satisfactorily mitigate or avoid the adverse impact other than the denial of the housing development or conditional approval of the housing development at a lower density.
- (b) If the housing development includes 20 percent of units affordable to very low or low-income households, 100 percent of units affordable or moderate or middle income households, or an emergency shelter, the Planning Commission shall approve the housing development unless the Planning Commission makes written findings supported by a preponderance of the evidence in the record, as to at least one of the findings in Government Code §65589.5(d).

### (2) Decision Timeframes. The Planning Commission shall approve or deny the housing development within the following applicable period:

- (a) 90 days from Environmental Impact Report certification;
- (b) 60 days from Environmental Impact Report certification for an affordable housing development consistent with Government Code §65950(a)(3);
- (c) 60 days from adoption of a Negative Declaration; or
- (d) 60 days from determination of CEQA exemption.

## H. Post-Decision Procedures. Post-decision procedures for the required permit (full application) shall be followed provided those procedures do not conflict with applicable Government Code sections for housing developments (i.e., Housing Accountability Act, Government Code §65589.5).

*This page intentionally left blank*

Figure 22.10.020.1: Process for Developments Eligible for Senate Bill 35 Streamlining with 150 units or Fewer (Government Code §65913.4)

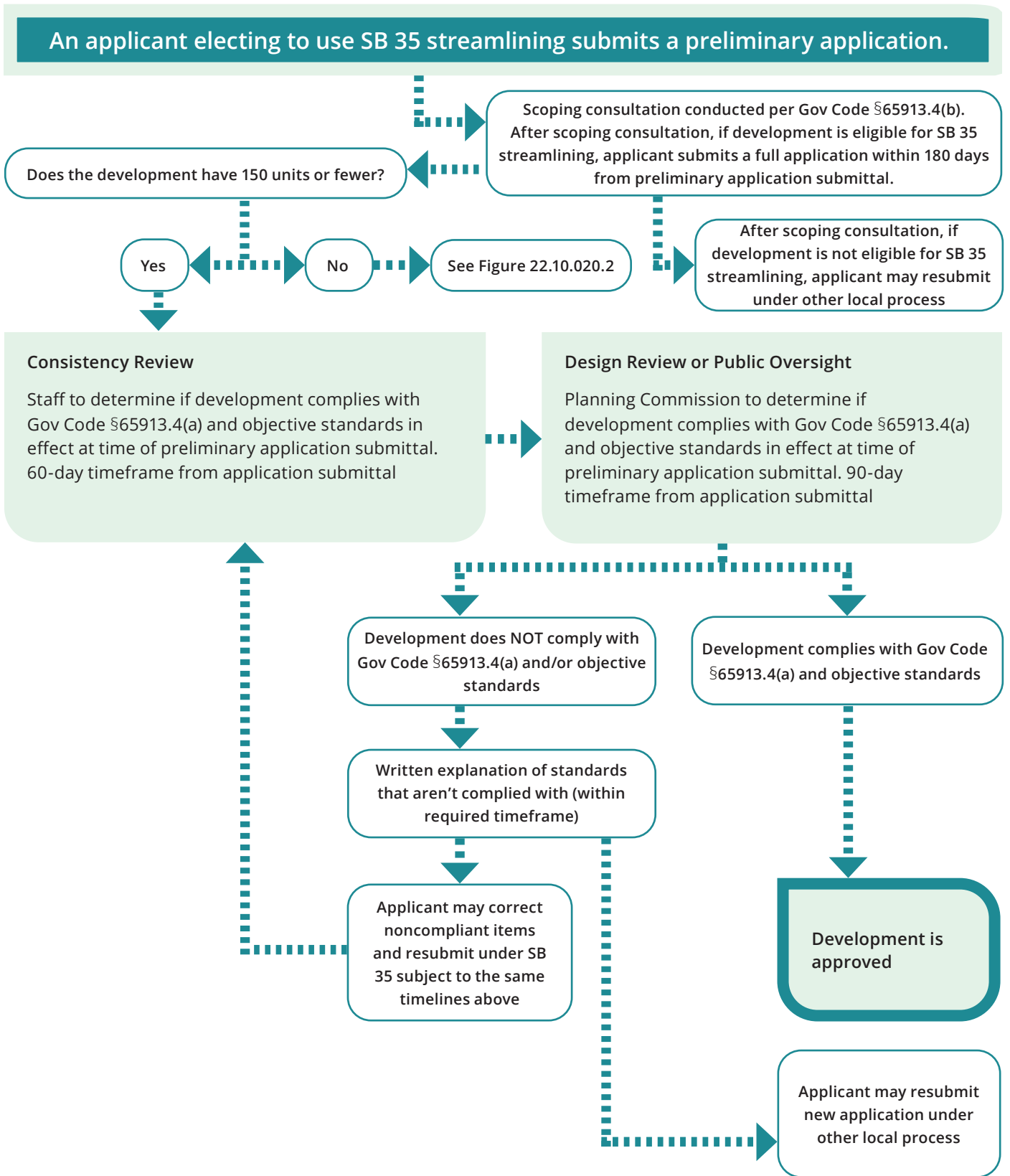


Figure 22.10.020.2: Process for Developments Eligible for Senate Bill 35 Streamlining with 151 units or More (Government Code §65913.4)

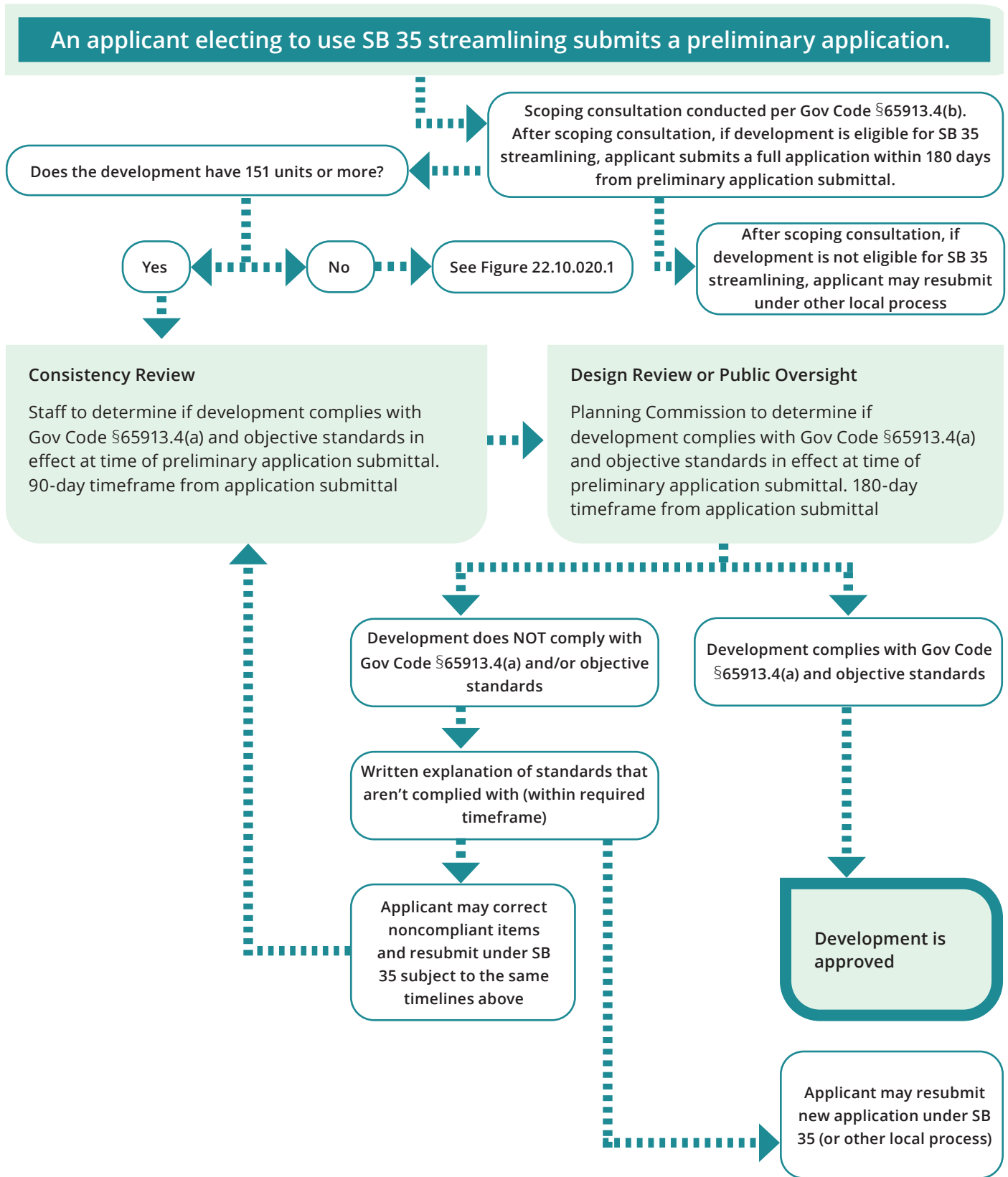
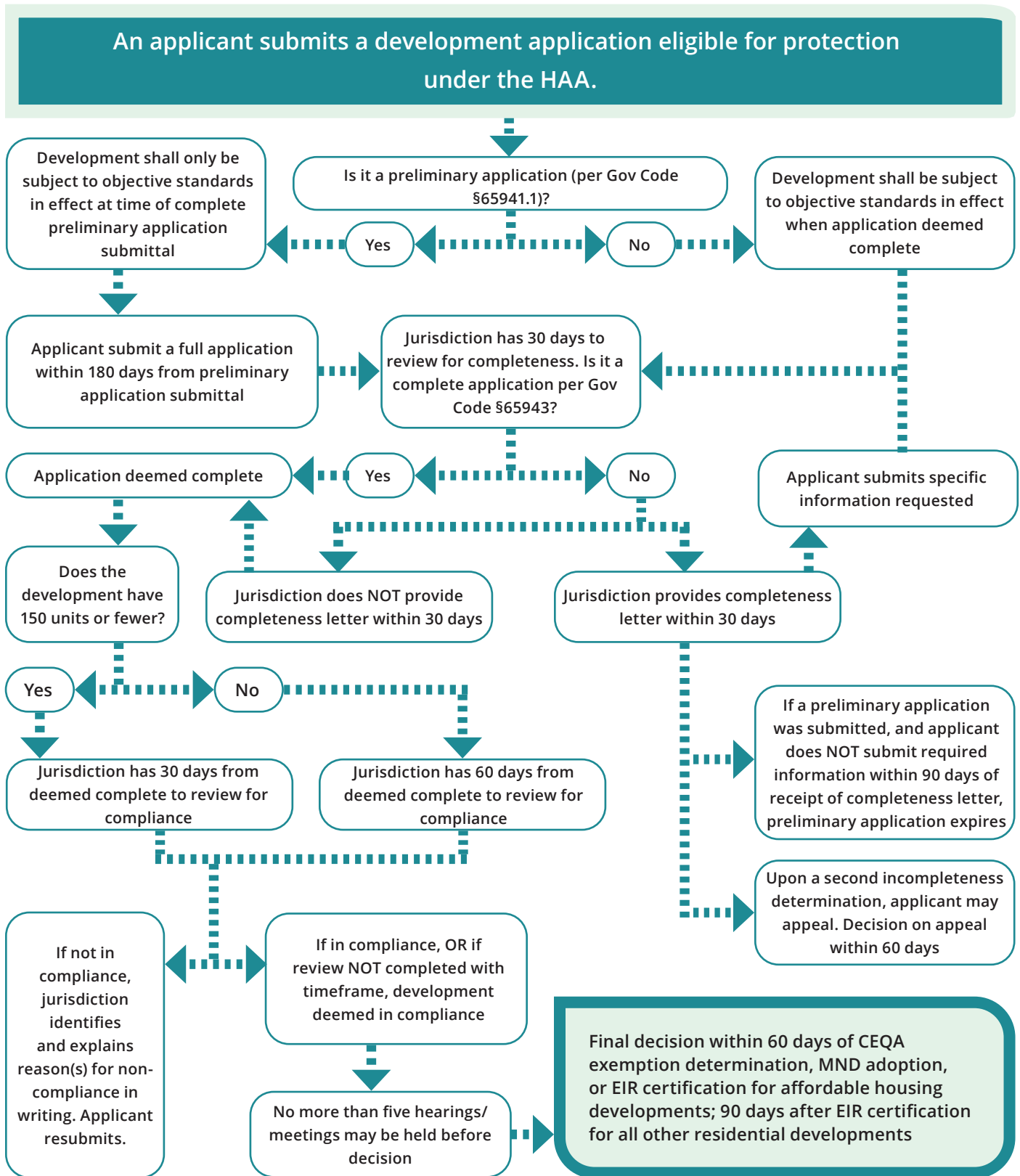


Figure 22.10.020.3: Process for Developments Eligible for Housing Accountability Act (HAA) Protection (Government Code §65589.5)



---

### 22.10.030 Adjustments to Standards

1. **Purpose.** This Section is intended to allow for minor deviations from certain standards in this FBC for specific situations because of the prescriptive nature of the standards. This does not include requests for variances as described in Chapter 19.84 (Variances).
2. **Applicability.** This Section applies to developments subject to Section 22.10.020 (Procedures). The Planning Commission may grant an Adjustment for only the standards identified in Table A (Adjustments to Standards for Design Sites Less Than 6% Slope).
3. **Procedures.** Adjustment requests shall be reviewed and processed as follows:
  - A. If the development for which an Adjustment is requested is being processed consistent with Section 22.10.020 (Procedures), the Adjustment shall be processed concurrently and consistent with the applicable procedures in Section 22.10.020 (Procedures); or
  - B. If the requested amount of deviation exceeds that allowed by this Section, the request does not qualify for an adjustment, and must be revised in compliance with this Section or withdrawn.
  - C. Adjustment requests involving any of the following features (i.e., historic building/feature, tree, rock outcrop, and/or utility infrastructure) shall be accompanied by existing conditions documentation identifying the feature(s).
  - D. Depending on the unique characteristics and dimensions on an individual parcel, it is possible that the full development potential of the zone may not be achievable even after applying the allowed adjustments in this Section.



**Table 22.10.030.A: Adjustments to Standards for Design Sites Less Than 6% Slopes**

<b>Administrative Relief Type</b>	<b>Required Findings</b>	<b>Allowed Administrative Relief</b>	<b>Reference to Standard</b>
<b>1. Design Site Dimensions</b>			
a. <b>Depth or Width</b> Decrease in the minimum required or maximum allowed	i. An existing historic building/feature, tree, rock outcrop, and/or utility infrastructure prevents compliance with the standard. <hr/> ii. An existing or new design site can be developed consistent with the intent of the zone as described in Subsection 1 of the zone.	Up to 10% of the standard	Subsection 3 of the zone
<b>2. Building Setbacks</b>			
a. <b>Front, Side Street, Side or Rear</b> Increase or decrease in the minimum to maximum required setback for a primary building and/or wing(s)	i. An existing historic building/feature, tree, rock outcrop, and/or utility infrastructure prevents compliance with the standard. <hr/> ii. An existing or new design site can be developed consistent with the intent of the zone as described in Subsection 1 of the zone.	Up to 15% of the standard for Front, Side Street or Rear; Up to 25% of the standard for Side	Subsection 5 of the zone
b. <b>Facade within Facade Zone</b> Reduction of the minimum amount of facade required within or abutting the facade zone	i. An existing historic building/feature, tree, rock outcrop, and/or utility infrastructure prevents compliance with the standard. <hr/> ii. An existing or new design site can be developed consistent with the intent of the zone as described in Subsection 1 of the zone. <hr/> iii. The horizontal unbuilt area resulting from this adjustment is landscaped per the standards in Section 22.05.030 (Landscaping and Lighting).	Up to 25% of the standard	Subsection 5 of the zone

Standards for private frontage apply [See Chapter 7 (Specific to Private Frontages)], and any adjustment shall not preclude the application of a private frontage type.

**Table 22.10.030.A: Adjustments to Standards for Design Sites Less Than 6% Slopes (Continued)**

Administrative Relief Type	Required Findings	Allowed Administrative Relief	Reference to Standard
<b>3. Building Footprint</b>			
a. <b>Size of Main Body or Wing(s)</b> Increase in the allowed width or length	i. An existing historic building/feature, tree, rock outcrop, and/or utility infrastructure prevents compliance with the standard. <hr/> ii. An existing or new design site can be developed consistent with the intent of the zone as described in Subsection 1 of the zone. <hr/> iii. The wing(s) is one-story less in height than the main body. <hr/> iv. The building complies with the setbacks of the zone or as allowed to be adjusted by this Section.	Up to 10% of the standard	Subsection 3 of the building type
<b>4. Parking Location</b>			
a. <b>Front or Side Street Setback</b> Reduction in the required parking setback	i. An existing historic building/feature, tree, rock outcrop, and/or utility infrastructure prevents compliance with the standard. <hr/> ii. An existing or new design site can be developed consistent with the intent of the zone as described in Subsection 1 of the zone. <hr/> iii. The driveway is in compliance with the zone standards. <hr/> iv. The ground floor space remains habitable in compliance with the zone standards.	Up to 10% of the standard when the required setback is 20' or more.  Up to 20% of the standard when the required setback is less than 20'.	Subsection 7 of the zone

Standards for private frontage apply [See Chapter 7 (Specific to Private Frontages)], and any adjustment shall not preclude the application of a private frontage type.

*This page intentionally left blank*

# Chapter 11: Definitions

---

## Sections:

22.11.010	Purpose
22.11.020	Definitions
22.11.030	Measurement Methods

---

## 22.11.010 Purpose

This Chapter provides definitions for specialized terms and phrases used in this FBC. All other applicable definitions in Chapter 19.08 (Definitions) of Title 19 (Zoning) apply.

---

## 22.11.020 Definitions

### A. Definitions

**Abutting.** Having a common property line or district boundary, or separated by a private or public street or easement.

**Access or Service Drive.** A public or private way of paving or right-of-way of not more than 30 feet affording means of access to property.

**Access Frontage or Service Road or Street.** A public or private street or right-of-way of not less than minimum standards as specified by the subdivision ordinance of the City affording means of access to property.

**Accessory Dwelling Unit (ADU).** An attached or detached residential dwelling unit which provides complete living facilities for one or more persons, including permanent provisions for living, sleeping, eating, cooking, and sanitation, which is located on the same parcel as a single-unit dwelling.

**Accessory Structure (syn. Accessory Building).** A structure physically detached from, secondary and incidental to, and commonly associated with a primary structure or use on the same site. Accessory structures normally associated with a residential use property include, but are not limited to: garages (unenclosed or enclosed) for the storage of automobiles (including incidental restoration and repair), personal recreational vehicles, and other personal property; studios; workshops; greenhouses (noncommercial); enclosed cabanas and pool houses; and storage sheds. Accessory structures normally associated with a non-residential use property include, but are not limited to: garages (unenclosed or enclosed) for the storage of automobiles and work related vehicles and equipment (including incidental restoration and repair); storage structures; workshops; and studios.

**Accessory Structure, Major (Major Accessory Structure).** An accessory structure with a footprint greater than 120 square feet.

**Accessory Structure, Minor (Minor Accessory Structure).** An accessory structure with a footprint of 120 square feet or less.

**Addition.** The enlargement of an improvement accomplished by appending a new improvement.

**Adjacent.** Sharing a common design site line, or having design site lines separated only by an alley.

**Adjacent Buildings.** Two or more buildings located upon adjacent design sites.

**Affordable to Low-Income or Very-Low-Income Households.** Being of a condition in which sales prices or rental rates for a housing development conform with the current State Law.

**Affordable Housing Development.** A residential development consisting of five or more units, not including any bonus units requested, in which

- a. At least 20 percent of the total units are affordable to low-income households;
- b. At least 10 percent of the total units are affordable to very-low-income households; or
- c. At least 50 percent of the total units are senior housing (Government Code §65915(b) and Civil Code §51.2 and §51.3).

**Agriculture.** The use of the land for purposes including farming, agriculture, horticulture, floriculture, viticulture, and the necessary accessory uses for packing, treating, or storing the produce, provided that any such accessory uses shall be secondary to that of normal agricultural activities. Does not include the raising of animals or fowl for commercial purposes, or sale of any products at retail on premises, unless otherwise specified.

**Alley.** A public or private way to be used primarily for vehicular access to the back or side of a design site of real property that otherwise abuts a street.

**Allowed Use.** Uses that are allowed by right and are not subject to the conditions of approval, mandatory review periods, or expiration periods as required for Use Permits or Minor Use Permits.

**Alter.** To create physical change in the internal arrangement of rooms or the supporting members of a structure, or a change in the external appearance of any structure, not including painting.

**Amusement Center or Facility.** A place of amusement, recreation, or entertainment, involving assemblages of people.

**Ancillary Structure (syn. Ancillary Building).** See "Accessory Structure."

**Animal Shelter.** Any place where animals or birds are kept, bred, groomed, trained or treated for compensation; or any such place where animals or birds are sold.

**Antenna.** Any system of wires, poles, rods, reflecting discs, or similar devices used for the transmission or reception of electromagnetic waves when such system is either external to or attached to the exterior of a structure. Antennas shall include devices having active elements extending in any direction and directional beam-type arrays having elements carried by and disposed from a generally horizontal boom that may be mounted upon and rotated through a vertical mast or tower interconnecting the boom and antenna support, all of which elements are deemed to be a part of the antenna.

**Apartment, Efficiency.** A dwelling unit in a multi-unit building, consisting of not more than one habitable room, excluding the kitchen or kitchenette and sanitary facilities, of a total floor area of not more than 400 square feet.

**Applicant.** Any individual, firm, or any other entity that applies to the City for the applicable permits to undertake any construction or development within the City.

**Architectural Feature.** Exterior building element intended to provide ornamentation to the building massing including, but not limited to: eaves, cornices, bay windows, window and door surrounds, light fixtures, canopies, and balconies.

**Attached Building or Structure.** Any building or structure which is structurally a part of or has a common wall and/or continuous roof with a primary building or structure, except where such connection is a breezeway or walkway incidental to and not a necessary part of the construction of the primary building.

**Auto and Vehicle Sales and Rental.** A retail or wholesale establishment selling and/or renting automobiles; trucks and vans; trailers; motorcycles; and scooters with internal combustion engines (bicycle sales are included under "General Retail"). May also include repair shops and the sales of parts and accessories incidental to vehicle dealerships. Does not include: the sale or rental of trailers, boats, RVs; businesses dealing exclusively in used parts, auto wrecking, and salvage; the sale of auto parts/accessories separate from a vehicle dealership (see "Auto parts sales"); or "Auto service stations," which are separately defined.

**Auto Disassembly or Wrecking.** The dismantling or disassembling of used motor vehicles or trailers, or the storage, sale, or dumping of dismantled, partially dismantled, obsolete, or wrecked vehicles or their parts.

**Auto Parts Sales.** Stores that sell new or re-manufactured automobile parts, tires, and accessories. Establishments that provide installation services are instead included under "Vehicle Services, Auto Repair Garage." Does not include businesses dealing exclusively in used parts, auto wrecking and salvage, or tire recapping establishments, which are found in compliance with "Vehicle Services, Auto Repair Garage."

**Auto Repair.** See "Vehicle Services."

**Auto Repair.**

1. **Auto Repair, Major.** General repair, rebuilding or reconditioning of engines, motor vehicles, or trailers; collision service including body or frame, straightening or repair, overall painting, or paint shop.
2. **Auto Repair, Minor.** Incidental minor repairs to include replacement of parts and service to passenger cars, but not including any operation defined as "automobile repair, major," or any other operation similar thereto.

**Auto Service Station.** A building and/or design site or use having pumps and storage tanks where motor vehicle fuels or lubricating oil, grease, or accessories for motor vehicles are dispensed, sold, or offered for sale at retail only; where deliveries are made directly into motor vehicles, including car washing and incidental accessory retail sales in a convenience market.

**Automated Teller Machine (ATM).** A computerized self-service machine used by bank and financial service patrons for conducting transactions, including deposits, withdrawals, and fund transfers, without contact with financial institution personnel. The machines may be located at or within banks, or in other locations, in compliance with this FBC.

**Average Slope.** The result of dividing the length of a slope by the difference in elevation at the top and bottom of the slope. See Section 22.11.030 (Measurement Methods).

**Awning.** A roof or cover which projects from a wall of a building over a window or door, made of canvas, aluminum, or similar material, which may be fixed in place or be retractable.

## B. Definitions

**Bank, Financial Services.** Financial institutions including: banks and trust companies; credit agencies; holding (but not primarily operating) companies; lending and thrift institutions; other investment companies; securities/commodity contract brokers and dealers; security and commodity exchanges; and vehicle finance (equity) leasing agencies.

**Base Flood Elevation.** As designated by Federal Emergency Management Agency (FEMA), the elevation of surface water resulting from a flood that has a one percent chance of equaling or exceeding that level in any given year.

**Basement.** A story whose floor is more than 12 inches, but not more than half of its story height below the average level of the adjoining finished grade (as distinguished from a "cellar," which is a story more than one-half below such level). A basement, when used as a dwelling, shall not be counted as a story for purposes of height measurement.

**Bathroom.** A room that contains all of the following features: a bathtub or shower, a washbowl, and a toilet.

**Bay.** Any division of a building between vertical lines or planes, especially the entire space included between two adjacent supports.

**Bay Window.** An architectural projection from the building cantilevered from the facade, consisting of one or more stories in height, containing at least 60 percent glass area.

**Bed & Breakfast (B&B).** A use of up to 10 sleeping units, where one unit equals one room, for the rental accommodation of transient guests on an overnight basis.

**Block.** An area of land separated from other areas by adjacent streets, railroads, rights-of-way, public areas, or the subdivision boundary.

**Block Face.** The aggregate of all the building facades on one side of a block. The block face provides the context for establishing architectural harmony.

**Block Length.** The horizontal distance from the right-of-way on one end of the block to the right-of-way on the other end along the same street.

**Block Perimeter.** The aggregate of all sides of a block bounded by the abutting rights-of-way.

**Block-Scale, Building.** A building that is individually as large as a block or individual buildings collectively arranged along a street to form a continuous facade as long as most or all of a block.

**Bonus.** See "Density Bonus."

**Building.** A structure consisting of one or more foundations, floors, walls, and roofs that surround an interior space, and may include exterior appurtenant structures including, but not limited to, porches and decks.

**Buildable Area.** The horizontal area in which a building is allowed to be constructed.

**Building Elevation.** The exterior wall of a building not adjacent to a public right-of-way, the front or side along a private street, or civic space.

**Building Entrance.** A point of pedestrian ingress and egress to the front of a building along the sidewalk of the street immediately adjacent to the building.



**Building, Existing.** See "Structure, Existing."

**Building Facade.** The exterior wall of a building adjacent to a street, the front or side along a private street, or civic space.

1. **Building Facade, Front.** The exterior wall of a building adjacent to a street or civic space.
2. **Building Facade, Side Street.** The exterior wall of a building adjacent to a side street.
3. **Building Facade, Interior Side.** The exterior wall of a building adjacent to the interior design site line(s).
4. **Building Facade, Rear.** The exterior wall of a building opposite the front.

**Building Form.** The overall shape and dimensions of a building.

**Building Frontage.** The facade(s) along the front and side street of the design site.

**Building Frontage, Principal.** The facade along the front of the design site, typically the narrower of sides and identified by an address.

**Building, Primary.** The building that serves as the focal point for all activities related to the principal use of the design site.

**Building, Setback.** See "Setback, Building."

**Business Support Services.** An establishment within a building that provides services to other businesses. Examples of these services include: blueprinting; computer-related services (rental, repair); copying and quick printing services; film processing and photofinishing (retail); and mailing and mail box services. Does not include sales, storage or rental of heavy equipment.

**Building Type.** A structure defined by its combination of configuration, disposition, and function.

**By-Right, Approval.** Approval by administrative staff of certain uses, improvements, and developments not requiring further review and in compliance with all applicable standards.

## C. Definitions

**Cafe.** See "Restaurant, cafe or coffee shop."

**Camping and Picnicking Areas.** This land use is intended for picnicking and camping areas, which may include individual campsites, but where utility hookups for recreational vehicles are typically not provided at campsites.

**Carriage House.** A second permanent dwelling that is accessory to a primary dwelling on the same site. A carriage house provides complete, independent living facilities for one or more persons, including permanent provisions for living, sleeping, eating, cooking, sanitation, and parking, and if attached to the primary dwelling, is provided exterior access separate from the primary dwelling. See Section 22.06.040 (Carriage House).

**Carshare Parking Space.** A parking space required to be dedicated for current or future use by a carshare service through a deed restriction, condition of approval, or license agreement. Such deed restriction, condition of approval, or license agreement shall grant priority use to any carshare service that can make use of the space, although such spaces may be occupied by other vehicles so long as no carshare organization can make use of the dedicated carshare space(s).

**Car wash.** A place where motor vehicles are vacuumed, cleaned, washed, and/or waxed. Does not include the retail sale of motor vehicle fuels.

**Carshare Service.** A service that provides a network of motor vehicles available to rent by members by reservation on an hourly basis or in smaller intervals.

**Catering service.** A businesses that prepares food for consumption on the premises of a client.

**Ceiling Height, Ground Floor.** The height from finished floor to finished ceiling of primary rooms on the ground floor, not including secondary rooms which include, but are not limited to: bathrooms, closets, utility rooms, and storage spaces.

**Ceiling Height, Upper Floor(s).** The height from finished floor to finished ceiling of primary rooms on the floor(s) above the ground floor, not including secondary rooms which include, but are not limited to: bathrooms, closets, utility rooms, and storage spaces.

**Cellar.** That portion of a building between floor and ceiling which is wholly or partly below grade and so located that the vertical distance from grade to the floor below is equal to or greater than the vertical distance from grade to ceiling. A cellar shall not be counted as a story, for the purpose of height standards.

**Center.** Concentration of ground floor shopping, restaurants, and services, with additional offices and housing located above, within a Walkable Urban context.

**Child Day Care.** Facilities for nonmedical care and supervision of minor children for periods of less than 24 hours. This land use includes the following types of facilities, all of which are required to be licensed by the California State Department of Social Services:

1. **Day Care Center.** Commercial or non-profit child day care facilities designed and approved to accommodate 15 or more children. Includes infant centers, preschools, sick-child centers, and school-age day care facilities. These may be operated in conjunction with other approved land uses, or as an independent land use.
2. **Large Family Day Care Home.** A day care facility located in a single-unit residence where an occupant of the residence provides care and supervision for 7 to 14 children. Children under the age of 10 years who reside in the home count as children served by the day care facility.
3. **Small Family Day Care Home.** A day care facility located in a single-unit residence where an occupant of the residence provides care and supervision for either six or fewer children, or eight or fewer children provided that no more than two of the children are under the age of two and at least two of the children are over the age of six. Children under the age of 10 years who reside in the home count as children served by the day care facility.

**Chamfered.** A transitional edge between two faces of an object. Sometimes defined as a form of bevel, it is often created at a 45° angle between two adjoining right-angled faces.

**Chamfered Facade Corner.** An external wall of a building joining two perpendicular exterior walls, typically at a symmetrical, 45 degree angle creating a beveled edge to the building rather than a 90 degree corner.

**Civic.** A term defining not-for-profit organizations that are dedicated to arts, culture, education, religious activities, recreation, government, transit, and public parking facilities.

**Civic Building.** A structure operated by governmental or not-for-profit organizations and limited to civic and related uses.

**Civic Space.** An outdoor area dedicated for public gathering and civic activities. See Section 22.09.040 (General to Civic Space).

**Coffee Shop.** See "Restaurant, cafe or coffee shop."

**Commercial.** A term defining service and retail uses collectively.

**Commercial Amusement Facility.** Establishments providing indoor amusement and entertainment services for a fee or admission charge, including:

1. Bowling alleys;
2. Coin-operated amusement;
3. Dance clubs;
4. Electronic game arcades (video games, pinball, etc.);
5. Gyms and recreation facilities;
6. Ice skating and roller skating; and
7. Pool and billiard rooms.

This use does not include adult oriented businesses, which are separately defined.

**Commercial Recreation Facility.** To include commercial amusement facilities (unlimited capacity amusement parks, arenas, auditoriums, convention centers, or stadiums); golf courses and country clubs; outdoor theaters; private swim clubs; and recreation centers.

1. **Commercial Recreation Facility, Indoor.** Establishments providing indoor amusement and entertainment services for a fee or admission charge, including: bowling alleys; coin-operated amusement arcades; night clubs; electronic game arcades (video games, pinball, etc.); ice skating and roller skating; and pool and billiard rooms as primary uses. Eight or more electronic games or coin-operated amusements in any establishment, or a premises where 50 percent or more of the floor area is occupied by amusement devices, are considered an electronic game arcade as described above; seven or fewer machines are not considered a land use separate from the primary use of the site.
2. **Commercial Recreation Facility, Outdoor.** A facility for various outdoor recreational activities, where a fee is charged for use. Examples include: amusement and theme parks; camping and picnicking areas; go-cart tracks; golf driving ranges; miniature golf courses; and water slides. May also include commercial facilities customarily associated with the above outdoor commercial recreational uses, including bars, restaurants, video game arcades, etc. Does not include golf courses, which are separately defined.

**Common Courtyard.** An entry court, forecourt, or courtyard shared by multiple residential units or commercial spaces.

**Common Open Space.** An entry court, forecourt, courtyard, or other on-site open space shared by multiple residential units or non-residential units.

**Common Space (syn. Common Area).** A portion of a development held in common and/or single ownership, is not reserved for the exclusive use or benefit of an individual tenant or owner, and is available for use by all persons who reside or work in the building or on the design site.

**Communication Equipment Building.** A building housing operating electrical and mechanical equipment necessary for the conduct of a communications business with or without personnel.

**Communications Tower.** Any structure which supports an antenna.

**Community Assembly.** A facility available for public assembly, such as a conference hall, club hall, lodge, performing arts center, amphitheater, or event facility, or for religious worship, such as a church, temple or mosque.

**Community Care Facility.** Residential care facilities for the elderly, alcoholism recovery, and homes for mentally disordered, handicapped, dependent, and neglected children.

**Community Center.** A multi-purpose meeting and recreational facility typically consisting of one or more meeting or multi-purpose rooms, kitchen, and/or outdoor barbecue facilities, that are available for use by various groups for such activities as meetings, parties, receptions, dances, etc.

**Community Garden (Use Type).** Land used for the cultivation by multiple users, of fruits, vegetables, plants, flowers, or herbs.

**Condominium.** An estate in real property consisting of an undivided interest in common in a portion of the property together with a separate interest in space called a unit, the boundaries of which are described on a recorded final map, design site map, or condominium plan. The condominium may be commercial, industrial, residential, or any combination. [Civil Code §783, §1351(f)].

**Condominium Conversion.** The conversion of an existing structure into separately owned commercial, industrial, or mixed-use units.

**Convenience Market.** A market serving neighborhood needs, of less than 5,000 square feet inside, offering a broad selection of goods, but with less than 20 percent of the sales floor area devoted to the display of alcoholic beverages.

**Corner Element.** A physical distinction in a building at the corner of two streets or a street and public space.

**Corner Entry.** An entrance located on the corner of a building.

**Cornice.** The crown molding of a building or element.

**Cottage Court.** See Section 22.06.080 (Cottage Court).

**Council.** The City Council of the City of Belvedere.

**Courtyard (syn. Court).** An unroofed area that is completely or partially enclosed by walls or buildings on at least two sides and often shared by multiple residential units or non-residential units, not including off-street parking.

**Courtyard Building, Neighborhood.** See Section 22.06.110 (Neighborhood Courtyard).

### Coverage

1. **Coverage, Accessory Structures.** The sum of the footprint area of all structures on a design site.
2. **Coverage, Building.** The floor area of the largest story of a building divided by the total design site area.
3. **Coverage, Design Site.** The portion of the design site expressed as a percentage that is covered in buildings or other structures.

**Co-working Space.** A facilitated environment which may contain shared facilities including, but not limited to: conference rooms, reception services, phones, and other business amenities. Work spaces are used by a recognized membership who share the site in order to interact and collaborate with each other as part of a community and to reduce duplicated costs by sharing facilities. The uses shall have externally observable attributes similar to uses allowed in the zone in which that they are located. Equipment is limited to those which do not generate noise or pollutants in excess of what is customary within a typical office environment. Such space located in a research & development building may use equipment consistent with research & development uses. Co-working space may be interchangeably referred to as "incubator space."

**Cul-de-sac.** A street which connects to another public street only at one end and is not planned for later extension.

**Crawl Space.** A shallow unfinished uninhabitable space beneath the floor or under the roof of a building, that provides access to utility, structural, and other building components not readily accessible from the habitable portions of the building.

**Crenel.** A notch between two merlons (solid upright section of a crenellated parapet), often found in medieval architecture.

**Crenellated.** Having regularly-spaced, often rectangular gaps, often referring to a parapet or battlement in medieval architecture.

**Crenellation.** The series of regularly-spaced, often rectangular crenels along a parapet.

#### D. Definitions

**Dance Club.** Any dance open to the general public, whether or not a fee is charged for admission, but where such activity is in connection with any commercial activity.

**Dangerous or Objectionable Elements.** Any land or building structure used or occupied in any manner so as to create any dangerous, injurious, noxious, or otherwise objectionable fire, explosive, or other hazard; noise or vibration, smoke, dust, odor, or other form of air pollution; heat, cold, dampness, electrical, or other disturbance; glare; liquid or solid refuse or wastes; or other substance, condition or elements in such manner or in such amount as to adversely affect the surrounding area or adjoining premises.

**Days.** Calendar days unless this FBC specifies otherwise.

**Dedication.** The transfer by a subdivider to a public entity of title to real property or an interest therein, or of an easement or right in real property, the transfer of facilities, the installation of improvements, or any combination of these. [Title 18 (Subdivisions)]

**Defensible Space.** A public, private, or semi-private residential environment whose physical characteristics—building layout and site plan—function to allow inhabitants themselves to become key agents in ensuring their security.

**Density Bonus.** A density increase over the maximum allowable residential density of the zone. See Government Code §65915 for types of bonuses.

**Dentils.** Small, rectangular blocks found under a cornice in classical architecture. A decorative element, dentils bear resemblance to teeth, their namesake.

**Department.** Belvedere's Planning Department.

**Depth, Ground-Floor Space.** The distance from the street-facing facade to the rear interior wall of the ground-floor space available to an allowed use.

**Depth-to-Height Ratio.** The relationship of the depth of a space measured perpendicular to a building divided by the average height of the buildings adjacent to the space.

**Design Site.** A portion of land within a parcel, delineated from other design sites and/or parcels to accommodate no more than one building type. The main purpose of a design site is to allow a parcel large enough to contain more than one building type to contain multiple building types while not requiring the legal subdivision of the parcel into additional parcels.

1. **Design Site, Corner.** A design site located at the intersection of two or more streets, where they intersect at an interior angle of not more than 175 degrees. If the intersection angle is more than 175 degrees, the design site is considered an interior design site.
2. **Design Site, Flag.** A design site not meeting minimum design site frontage standards and where access to a public or private street is provided by means of a long, narrow driveway between abutting design sites.
3. **Design Site, Interior.** A design site abutting only one street.
4. **Design Site, Through.** A design site with two or more frontage lines that do not intersect.

**Design Site Area.** The total square footage or acreage of horizontal area included within the design site lines.

**Design Site Coverage.** See "Coverage."

**Design Site Depth.** The horizontal distance between the front design site line and rear design site line of a design site measured perpendicular to the front design site line.

**Design Site Line.** The perimeter and geometry of a design site demarcating one design site from another.

1. **Design Site Line, Front.** One of the following:
  - a. The frontage line in the case of a design site having a single frontage line;
  - b. The shortest frontage line in the case of a corner design site with two frontage lines, neither of which are adjacent to a thoroughfare or a design site with independent frontage;
  - c. The frontage line generally perceived to be the front design site line in the case of a corner design site with three or more frontage lines, none of which are adjacent to a thoroughfare or a design site with independent frontage;
  - d. The frontage line adjacent to a thoroughfare in the case of a corner design site with two or more frontage lines, one of which is adjacent to a thoroughfare;
  - e. The frontage line adjacent to a design site with independent frontage in the case of a corner design site with two or more frontage lines, one of which is adjacent to a design site with independent frontage; or
  - f. The frontage line adjacent to the front design site line of an adjacent design site in the case of a through design site.
2. **Design Site Line, Rear.** That design site line opposite the front design site line.
3. **Design Site Line, Side.** Design site lines connecting the front and rear design site lines.

**Design Site Width.** The horizontal distance between the design site lines measured perpendicular to the front design site line.

**Detached.** Separate or unconnected.

**Development Site.** The parcel(s) or portion(s) thereof on which proposed structures and improvements are to be constructed.

**Diligently Pursued.** Continued with constant or appropriate effort.

**Director.** Director of Planning and Building, an appointed representative.

**Display.** An item or arrangement of items indoors that is not attached to a window, door or wall.

**Disposition, Formal.** Composed in a formal arrangement, in a regular, classical, and typically symmetrical manner.

**Disposition, Informal.** Composed in an informal character with a mix of formal and natural characteristics.

**Disposition, Natural.** A preservation of the existing natural condition or a composition of elements arranged as they would appear in nature, with irregular shapes and asymmetry.

**Distance Between Entries.** The horizontal distance between entrances to a building or buildings, measured parallel to the facade.

**Drive-in Business.** Any business that either by design or operation provides services or products directly to occupants of a motor vehicle, except gasoline service stations.

**Drive-through Service.** Any business that either by design or operation provides services or products directly to occupants of a motor vehicle, except gasoline service stations.

**Driveway.** A vehicular lane within a design site, or shared between two design sites, usually leading to a garage, other parking, or loading area.

**Duplex Side-by-Side.** See Section 22.06.060 (Duplex Side-by-Side).

**Duplex Stacked.** See Section 22.06.070 (Duplex Stacked).

**Dwelling, Group Living (syn. Cohousing).** Dwellings designed for occupancy of groups living together and having a central dining facility.

**Dwelling, Multiple.** A building designed or used for three or more dwelling units.

**Dwelling, Second Unit.** A separate, complete housekeeping unit with a separate entrance, kitchen, sleeping area, and full bathroom facilities, which is an attached or detached extension to an existing single-unit structure.

**Dwelling Unit.** A room or group of internally connected rooms that have sleeping, cooking, eating, and sanitation facilities, but not more than one kitchen, which constitute an independent housekeeping unit, occupied by or intended for one household on a long-term basis.

**Dwelling Unit, Stacked.** A dwelling unit situated immediately above or below another dwelling unit.



## E. Definitions

**Eave.** The edge of the roof that overhangs the face of the adjoining wall. The bottom of the eave can range from exposed rafters (“open eave”) to a finished horizontal surface (“closed eave”).

**Elevated Ground Floor.** A ground floor situated above the grade plane of the adjacent sidewalk.

**Emergency Shelter.** A facility for the temporary overnight shelter operated by a public or non-profit agency. Does not include charitable food distribution, which is not regulated by FBC.

**Encroachment.** Any architectural feature, structure, or structural element—including, but not limited to, a gallery, fence, garden wall, porch, stoop, balcony, bay window, terrace, or deck—that breaks the plane of a vertical or horizontal regulatory limit by extending: into a setback, beyond the build-to-line into the public frontage, or above a height limit.

**Entablature. Syn. Expression Line.** A horizontal, continuous lintel on a classical building supported by columns or a wall, comprising the architrave, frieze, and cornice.

**Entasis.** A slight convex curve in the shaft of a column, introduced to correct the visual illusion of concavity produced by a straight shaft.

**Entry.** An opening, including, but not limited to, a door, passage, or gate, that allows access to a building.

1. **Entry, Primary.** The opening that allows access to a building directly from the sidewalk along the front facade.
2. **Entry, Service.** An entrance located toward or at the rear of the building intended for the delivery of goods and removal of refuse.

**Equestrian Facility.** A commercial facility for horses, donkeys, and/or mules, including: horse ranches; boarding stables; riding schools and academies; horse exhibition facilities (for shows or other competitive events); and barns, stables, corrals, and paddocks, accessory and incidental to these uses. Does not include the simple pasturing of horses, donkeys, and/or mules.

**Established Landscape.** The point in time at which plants have developed roots into the soil adjacent to the root ball.

**Establishment Period.** The first year after installing a plant in a landscape.

**External Employees.** An employee who does not reside at his or her place of employment.

## F. Definitions

**Facade.** See "Building Facade."

**Facade Zone.** The area between the minimum and maximum setback lines along the front of a design site and along the side street of a corner design site where the building facade is required to be placed. The zone standards identify the minimum amount of facade to be placed in the facade zone. See Section 22.11.030 (Measurement Methods).

**Facility.** An improvement, structure, or building that is designed and used for a particular purpose.

**Farm Equipment Sales and Service.** The retail sale, rental, or repair of agricultural machinery, equipment, and supplies for use in: soil preparation and maintenance; the planting and harvesting of crops; and other operations and processes pertaining to farming and ranching. Includes commercial farm equipment sales, rental, and repair; farm and dairy supply and equipment repair; and feed sales.

**Farmworker Housing.** Any attached or detached dwelling unit used to house farm/agricultural workers and their family members, including temporary mobile homes. For the purpose of calculating density, no more than one food preparation area shall be provided for each farmworker housing unit.

**Fast-Food Business.** A restaurant with a drive-through facility providing food service directly to occupants of a motor vehicle.

**Fence.** A structure, made of wood, metal, masonry, or other material, typically used to screen, enclose, or divide open space for a setback or along a design site line.

**Finish Level, Ground Floor.** (Base Flood Elevation plus One Foot). Height difference between the finished floor on the ground floor and the adjacent sidewalk. In the case of a terrace frontage that serves as the public right-of-way, the floor finish level is the height of the walk above the adjacent street. Standards for ground floor finish level for ground floor residential uses do not apply to ground floor lobbies and common areas in multi-unit buildings.

**Financial services.** See "Bank, Financial Services."

**Fitness Facility.** A fitness center, gymnasium, or health and athletic club, which may include any of the following: sauna, spa, or hot tub facilities; indoor tennis, handball, and racquetball; archery and shooting ranges; and other indoor sports activities. Does not include adult entertainment businesses.

**Flex Space.** A room or group of internally connected rooms designed to accommodate an evolution of use over time in response to an evolving market demand. Typically designed to accommodate future commercial uses, while accommodating less intense short-term uses, including, but not limited to, residential or live/work, until the commercial demand has been established.

**Flood Hazard.** The threat of overflow stormwaters having the capability to flood lands or improvements, transport or deposit debris, scour the surface soil, dislodge or damage structures, or erode the banks of channels.

**Floor Area.** The sum of the gross areas of all stories of a building, measured from the exterior faces of the exterior walls. The floor area shall include any building that has a roof and is enclosed so as to provide shelter from the elements on three or more sides.

**Floor to Lot Area Ratio.** The floor area of the building divided by the total design site area.

**Floor Coverage.** See "Coverage."

**Floorplate.** An area measurement in square feet of either the gross or the rentable floor area of a typical floor in a building.

**Floorplate, Commercial.** The square footage area measurement of a floorplate dedicated to commercial uses.

**Floorplate, Non-residential.** The square footage area measurement of a floorplate dedicated to non-residential uses.

**Floorplate, Residential.** The square footage area measurement of a floorplate dedicated to residential uses.

**Flow Rate.** The rate at which water flows through pipes and valves, measured in gallons per minute or cubic feet per second.

**Food Store.** A business establishment principally intended to provide retail food sales and related products and services otherwise allowed within the zone in which the business is located.

**Footprint Area.** The total square footage contained within a footprint.

**Footprint, Building.** The outline of the area of ground covered by the foundations of a building or structure.

**Forecourt.** See Section 22.07.080 (Forecourt).

**Form-Based Zone (syn. Transect Zone).** One of several zones applied to parcel(s) subject to Title 22 (Objective Design and Development Standards). See Belvedere Objective Design Standards Zones Map.

**Fourplex.** See Section 22.06.090 (Fourplex).

**Freestanding Wall.** A wall that is separate from a building and supported by independent means.

**Front.** See "Design Site Line, Front."

**Front Loaded.** (Front Access). Design sites that provide vehicular access from the front of the design site.

**Frontage, Private.** The area between the building facade and the back of the sidewalk abutting a street (public or private) or public open space.

**Frontage, Public.** The area between the on-street parking and the back of the sidewalk.

**Frontage Line.** The design site line(s) of a design site fronting a street (public or private) or a civic space.

**Frontage Type.** A physical element configured to connect the building facade to the back of the sidewalk abutting a street or public open space depending on the intended physical character of the zone.

**Fuel Station, Private.** A private motor fuel dispensing facility exclusively serving the business occupying the subject property and not involving either wholesale or retail sales of motor vehicle fuels to other individuals or businesses.

**Funeral Home.** A room or chapel from which funeral services may be conducted.

**Furniture Area.** An area of space that allows for the placement of furniture without restricting the movement of pedestrians.

## G. Definitions

**Gable.** A vertical wall in the shape of a triangle formed between the cornice or eave and the ridge of the roof.

**Gallery.** See Section 22.07.120 (Gallery).

**Ganged.** Refers to windows designed/found in an array of two or more.

**Garage.** A structure, or part thereof, used or intended to be used for the parking and storage of motor vehicles.

1. **Garage, Private.** A building or portion of a building, in which only motor vehicles used by the tenants of the building or buildings on the premises are stored or kept.
2. **Garage, Public.** A structure or portion thereof, other than a private garage, used for the storage, sale, hire, care, minor or major repair, or refinishing of self-propelled vehicles or trailers; except, that a structure or part thereof used only for storage or display of self-propelled passenger vehicles, but not for transients, and at which automobile fuels and oils are not sold and motor driven vehicles are not equipped, repaired, or hired, shall not be deemed to be a public garage

**General Retail.** Stores and shops selling many lines of merchandise. Examples of these stores and lines of merchandise include: bicycle sales, service, and rental; bookstores, except adult bookstores; apparel and accessories; bakeries; and food stores.

**Glazing.** Openings in a building in which glass is installed.

**Grade.** The finished ground level at any point along the exterior walls of a structure. Where walls are parallel to and within five feet of a sidewalk, alley or other public way, the level above ground shall be measured at the elevation of the sidewalk, alley or public way. Also see "Grade, Finished."

**Grade, Finished.** The final ground surface elevation after the completion of grading or other site preparation related to a proposed development that conforms to an approved Grading Permit or Building Permit. In cases where substantial fill is proposed, "finished grade" shall be established by the Director consistent with design sites in the immediate vicinity and shall not be, nor have been artificially raised to gain additional building height. Also see "Grade."

**Grade, Pre-Development.** The grade of a design site prior to any site improvements related to the proposed development.

**Grading.** Earthwork performed to alter the natural contours of an area.

**Green Building Practices.** A whole-systems approach to the design, construction, and operation of buildings and structures that helps mitigate the environmental, economic, and social impacts of construction, demolition, and renovation. Green building practices including, but not limited to, those described in the LEED™ rating system recognize the relationship between natural and built environments and seek to minimize the use of energy, water, and other natural resources and provide a healthy, productive environment.

**Ground Floor.** The floor of a building located nearest to the level of the ground around the building.

**Gross Floor Area.** The total floor area inside the building envelope, including the external walls, but not including the roof.

**Ground Floor Ceiling Height.** Height from finished floor to finished ceiling of primary rooms on the ground floor, not including secondary rooms including, but not limited to: bathrooms, closets, utility rooms, and storage spaces.

**Gross Parking Area.** The total area of parking space and drive included on a design site.

**Gross Residential Acreage.** The total area, measured in acres, included within the design site lines of a residential development.

**Guest House.** A detached structure accessory to a single dwelling, accommodating living/sleeping quarters, but without kitchen or cooking facilities.

## H. Definitions

**Habitable Space.** The portion of a building that is suitable for human occupancy.

**Hardscape.** Paving, decks, patios, and other hard, non-porous surfaces.

### Height

1. **Height, Number of Stories.** The number of stories in a structure allowed above adjacent finished grade. See "Stories."
2. **Height, Overall.** The vertical distance between adjacent finished grade and the highest part of the structure directly above.
3. **Height, Highest Eave/parapet.** The vertical distance between adjacent finished grade and the highest eave or parapet of the building.

**Height, Above Grade.** See Section 19.08.240 (Height).

**Height Measurement on a Sloping Design Site.** This is addressed in Section 22.11.030 (Measurement Methods).

**High Water-use or Non-drought-Tolerant Plant.** A plant that will require regular irrigation for adequate appearance, growth, and disease resistance.

**Historic Resource.** Any resource that has been designated as historic.

**Historical Structure.** Any building or structure listed on or eligible for listing on the national, state, or local register of historic resources.

### Home Improvement Sales and Services

1. **Major.** Home improvement services that include building materials (lumberyards); building materials and hardware; hardware only; paint, glass, and wallpaper; floor and window coverings; carpentry shop, custom woodworking, or custom furniture; food lockers, rental for individual households; spa and pool sales, supplies, service, and repair; and nursery sales (garden supply).
2. **Medium intensity.** Home improvement services that include hardware, including light building materials; paint, glass, wallpaper, and floor covering; and miscellaneous repair services, including only establishments engaged in the repairing and servicing of household and business equipment, machines, and furnishings.
3. **Minor.** Home improvement services that include building materials and hardware, excluding lumber yards, paint, glass, wallpaper, and floor covering; and miscellaneous repair services, including only establishments engaged in the repairing and servicing of household and business equipment, machines, and furnishings.

**Home Occupations.** Any use conducted entirely within a dwelling and conducted only by the inhabitants thereof, which use is clearly incidental and secondary to the use of the dwelling for dwelling purposes and does not change the character thereof, and is not evidenced beyond the limits of the property by noise, light, smoke, odor, vibration, electrical interference, storage of material or equipment, abnormal human activity, vehicular traffic, or other exterior evidences.

**Hotel or Motel.** Any building or portion thereof containing six or more guest rooms used, designed, or intended to be used, let, or hired out to be occupied by transients.

**House.** See Section 22.06.050 (House).

**House-Scale Building.** A building that is the size of a small-to-large house and detached from other buildings, typically ranging from 24 feet to as large as 80 feet overall, including wings.

#### I. Definitions

**Impervious.** The area of any surface that prevents the infiltration of water into the ground including, but not limited to, roads, parking areas, concrete, and buildings.

**Improved.** An area which has been paved or planted and is permanently maintained as such.

**Improvement.** The product of any modification to a site structure or building, not including maintenance or repairs.

**Infill.** The development of vacant land that was bypassed by earlier waves of development and is now largely surrounded by developed land.

**Irrigation Efficiency.** The measurement of the amount of water beneficially used divided by the amount of water applied. Irrigation efficiency is derived from measurements and estimates of irrigation system, characteristics, and management practices.

**Irrigated Landscape Area.** An entire design site less the building footprint, driveways, non-irrigated portions of parking lots, and other hardscape areas. Landscape areas encompass all portions of a development site to be improved with planting and irrigation. They include water bodies including, but not limited to, fountains, swimming pools, and ponds. Natural open spaces without irrigation systems are not included.

#### J. Definitions

*No specialized terms beginning with the letter J are defined at this time.*

#### K. Definitions

**Kennel.** A commercial facility for the grooming, keeping, boarding, or maintaining of five or more dogs (four months of age or older), or five or more cats except for dogs or cats for sale in pet shops, or in animal hospitals. Includes pet day care.

## L. Definitions

**L-Shaped (syn. Ell).** A horizontal form for the main body of a building or a massing composition, also referred to as an "Ell" which is an extension at a right angle to the length of a building.

**Laboratory.** A facility for testing, experimenting, analysis, and/or research. Examples of this use include medical labs, soils and materials testing labs, and forensic labs.

**Landing.** A level area at the top or bottom of a staircase or between one flight of stairs and another.

**Landscaping.** Flowers, shrubs, trees, or other decorative material of natural origin.

**LEED™ Rating System.** The most recent version of the Leadership in Energy and Environmental Design (LEED™) Commercial Green Building Rating System, or other related LEED™ rating system, approved by the U.S. Green Building Council.

**Limited Sub-Zones.** See Section 22.02.030 (Sub-Zones).

**Lined Building.** A two-part building consisting of an exterior occupiable building specifically designed to mask the interior building, which consists of a parking structure, building with few windows, or a parking lot, from a frontage.

**Liner Building.** An occupiable structure specifically designed to mask a parking lot or a parking structure from a frontage.

**Lintel.** A horizontal architectural member spanning and usually carrying the load above an opening.

**Listed Resource.** See "Historic Resource."

**Live/Work.** An integrated housing unit and working space, occupied and utilized by a single household in a structure, either single-unit dwelling or multiple-unit dwelling, that has been designed or structurally modified to accommodate joint residential occupancy and work activity, and which includes:

1. Complete kitchen space and sanitary facilities; and
2. Working space reserved for and regularly used by one or more occupants of the unit.

**Living Area.** The interior habitable area of a dwelling unit, including basements and attics, but not including garages or any accessory structure.

**Loading Dock(s).** A platform where cargo from vehicles can be loaded or unloaded.

**Loading Spaces, Off-street.** Permanently improved and maintained areas on the design site dedicated to loading and unloading of materials, equipment, and merchandise.

**Lodging.** See "Bed and Breakfast" or "Hotel or Motel."

**Lot.** See "Design Site."

**Low-Water-Use or Extra Drought-Tolerant Plant.** A plant that can survive without irrigation throughout the year once established, although supplemental water may be desirable during drought periods for improved appearance and disease resistance.



## M. Definitions

**Main Body.** The primary massing of a primary building.

**Main Facade.** The front facade of a building.

**Main Street Building.** See Section 22.06.140 (Main Street Building).

**Major.** Having a greater size, scope, effect, characteristic, or quality relative to the other corresponding sizes, scopes, effects, characteristics, or qualities; or being the greater of two or more.

**Maker Shopfront.** See Section 22.07.090 (Maker Shopfront).

**Manufacturing/Processing - Heavy Industrial.** The manufacturing, assembly, processing, storage, or packaging of products involving chemicals, petroleum, and heavy agricultural products or other hazardous materials.

**Manufacturing/Processing - Light Industrial.** Any manufacturing, storage, and distribution that does not include hazardous wastes or resulting large truck usage/parking on the site. The use shall be accomplished entirely inside of the building except for incidental movement of products or materials into and out of the building to a delivery vehicle. Size of an individual light distribution business shall generally be limited to 4,000 square feet of storage (warehouse) area and one truck delivery door.

**Manufacturing/processing - Medium Intensity.** The manufacturing, assembling, processing, storage, or packaging of products, except: manufacturing, assembling, processing, storage, or packaging of chemicals, petroleum, heavy agricultural products, or other hazardous materials; or vehicle-dismantling, scrap, and waste yards. Medium intensity manufacturing and processing includes:

1. The manufacturing of electric and electronic circuits, instruments, and devices including, but not limited to, radio and television, phonographic equipment, calculators, computers, semi-conductors and transistors, and similar uses;
2. The manufacturing, assembly, processing, storage, or packaging of products from previously prepared materials including, but not limited to: cloth plastic, paper, leather, and precious or semi-precious metals or stones; but not including such operations as saw and planing mills, and any manufacturing uses involving primary production of wood, metal, or chemical products from raw materials and similar uses; and
3. The manufacturing of pharmaceutical products.

**Massing.** The overall shape or arrangement of the bulk or volume of a building and structures.

**Median.** A planted or paved area which separates two roadways or divides a portion of a road into two or more lanes.

**Media Production.** Facilities for motion picture, television, video, sound, computer, and other communications and distribution services.

**Medical Services - Doctor Office.** A facility other than a hospital where medical, dental, mental health, surgical, and/or other personal health care services are provided on an outpatient basis. Includes dental, medical, optical, and x-ray laboratory offices. Counseling services by other than medical doctors or psychiatrists are included under "Offices - Professional/Administrative."

**Meeting Facility, Public or Private.** A facility for public or private meetings, including community centers, civic and private auditoriums, Grange halls, union halls, meeting halls for clubs and other membership organizations, etc. Also includes functionally related internal facilities including, but not limited to, kitchens, multi-purpose rooms, and storage. Does not include conference and meeting rooms accessory and incidental to another primary use that are typically used only by on-site employees and clients and occupy less floor area on the site than the offices they support. Does not include commercial entertainment facilities (see "Commercial Amusement Facility") or convention centers (see "Convention Center").

**Metal Products Fabrication.** An establishment engaged in the production and/or assembly of metal parts, including the production of: metal cabinets and enclosures, cans and shipping containers, doors and gates, duct work, forgings and stampings, hardware and tools, plumbing fixtures and products, tanks, towers, and similar products. Examples of these uses include: welding shops; sheet metal shops; plating, stripping, and coating shops; machine shops; saw sharpening; stone cutting and products; glass and glass products; and sheet metal.

**Minor.** Having a lesser size, scope, effect, characteristic, or quality relative to the average size, scope, effect, characteristic, or qualities; or being the lesser of two or more.

**Mixed-Use.** Multiple functions within the same building or the same general area through superimposition or within the same area through adjacency.

**Mobile Home.** A vehicle, other than a motor vehicle, designed and equipped to contain one or more dwelling units to be used without a permanent foundation, and which is in excess of 8 feet in width and in excess of 40 feet in length.

**Mobile Home Park.** Any site that is planned and improved to accommodate two or more mobile homes used for residential purposes; or any site on which two or more mobile home design sites are rented, leased, held out for rent or lease, or were formerly held out for rent or lease and later converted to a subdivision, cooperative, condominium, or other form of resident ownership, to accommodate mobile homes used for residential purposes.

**Moderate Water-Use or Semi-Drought-Tolerant Plant.** A plant that can survive throughout the year with occasional irrigation.

**Mortuary.** A funeral home where deceased are prepared for burial or cremation and funeral services may be conducted. Does not include on-site cremation.

**Multiplex.** See Section 22.06.130 (Multiplex).

**Multi-Unit Building.** A residential, non-residential, or mixed-use building in which there exists three or more separate units with direct exterior access and in which there are appurtenant shared facilities. Distinguishing characteristics of a multi-tenant building or use may, but need not, include common ownership of the real property upon which the building or use is located, common wall construction, and multiple occupant use of a single structure.

## N. Definitions

**Neighborhood Center.** A walkable environment that provides a mix of civic, institutional, and/or commercial uses.

**New Construction.** Structures for which the "start of construction" commenced on or after the effective date of this FBC.

**New Use.** Any purpose for which land or premises, or a building or structure thereon, is improved, occupied, utilized, built, or constructed for said purpose, which has not before existed on said land or premises.

**Night Club.** A facility serving alcoholic beverages for on-site consumption, and providing entertainment, examples of which include live music and/or dancing, comedy, etc.

**Nonconforming Design Site.** A design site that was legally created before the effective date of this FBC and does not comply with the minimum area, depth, width, or other applicable standards of the zone it is located.

**Nonconforming Site Improvement.** A site improvement (e.g., fences, landscaping, parking, walls, etc.) that conformed to the standards of the previous zoning that lawfully existed before the effective date of this FBC and does not conform to the present standards of the zone in which it is located.

**Nonconforming Structure or Building.** A structure or building that lawfully existed before the effective date of this FBC and does not conform to the present standards of the zone in which it is located.

**Nonconforming Use.** A use of a building, structure, or site, or portion thereof, or a building, structure or facility itself, which was lawfully established and maintained but, because of the application of this FBC to it, does not conform to the present standards of the zone in which it is located.

**Non-Street Frontage.** Building facades that do not face a street or civic space.

## O. Definitions

**Office.** This FBC distinguishes between the following types of offices. These do not include medical offices (see “Medical Service - Doctor Office.”).

1. **Office, Business/Service.** An establishment providing direct services to consumers. Examples of this use include employment agencies, insurance agent offices, real estate offices, travel agencies, utility company offices, elected official satellite offices, etc. This use does not include “Financial and Business Institutions,” which are separately defined.
2. **Office, Government.** An administrative, clerical, or public contact and/or service office of a local, state, or federal government agency or service facility. Offices are located on publicly owned land and necessary for the administration of federal, state, county, and city governments or local agencies as defined in the Government Code. Includes post offices, but not bulk mailing distribution centers, which are under “Warehousing and Distribution Facility.”
3. **Office, Professional/Administrative.** An office facility occupied by a business that provides professional services or is engaged in the production of intellectual property. Examples of this use include: accounting, auditing, and bookkeeping services; advertising agencies; attorneys; business associations and chambers of commerce; commercial art and design services; construction contractors (office facilities only); court reporting services; detective agencies and similar services; design services including architecture, engineering, landscape architecture, and urban planning; educational, scientific, and research organizations; financial management and investment counseling; literary and talent agencies; management and public relations services; media postproduction services; photographers and photography studios; political campaign headquarters; secretarial, stenographic, word processing, and temporary clerical employee services; and writers’ and artists’ offices.

**Office Amenity Space.** Non-employee, non-traffic-generating uses that are not easily convertible to employee-generating uses including, but not limited to, exterior covered walkways, lobby atrium, large cafeterias, employee lounge areas, employee fitness areas, and laboratories.

**Off-Site Hazardous Materials Storage Facility.** A facility, as defined in California Health and Safety Code §25117.1, that accepts hazardous wastes that are generated at another location (off-site) and serves more than one producer of hazardous waste.

**Off-Street Parking.** The area(s) located on a design site available for temporary storage of passenger vehicles, including a public or private parking lot where parking is the principal use of the property.

**Open Space.** See “Civic Space.”

**Open Space Easement.** See “Scenic Easement or Open Space Easement.”

**Open Structure.** An accessory structure having a roof constructed of lattice or other roof material which allows light and air to pass through a minimum of 50 percent of the roof surface. Additionally, the sides of an open structure consist only of support posts and decorative or functional elements including, but not limited to, braces and railings such that light and air can pass through a minimum of 75 percent of each side. Open structures include but are not limited to trellises, trellis-like patio covers, and other shade structures. Play structures do not qualify as open structures, but are regulated as minor or major accessory structures.

**Open Sub-Zones.** See Section 22.02.030 (Sub-Zones).

**Oriel Window (syn. Upper Story Bay Window).** A window that projects from the building facade or elevation, located on upper floors and may extend for multiple stories.

**Outdoor Sales Display.** An area where customers are encouraged to examine and/or experience merchandise in their typical configuration and/or manner of use.

**Outdoor Storage Building.** A building used primarily for storage of goods and materials, and uninhabitable.

**Overhead Doors.** Doors constructed in horizontally hinged sections that are equipped with hardware that rolls the sections into an overhead position, clear of the opening.

## P. Definitions

**Parapet.** A low wall along the edge of a roof or the portion of a wall that extends above the roof line.

**Parcel (syn. Lot).** A portion of land separate from others and delineated or described as a single integral unit on a subdivision map or by other map approved in compliance with the Subdivision Map Act (§66410 et seq.).

**Parcel Line Adjustment.** A shift or rotation of an existing parcel line between four or fewer existing, adjoining parcels, where the land taken from one parcel is added to an adjoining parcel and where a greater number of parcels than originally existed are not created, as provided in Section 18.28.010 (Lot Line Adjustments).

**Parcel Map.** A map prepared for the purpose of dividing a legal parcel into four or fewer parcels and prepared in compliance with the provisions of this Title 22 (Objective Design and Development Standards) and the Subdivision Map Act (§66410 et seq.) and in a manner to be recorded in the office of the County Recorder.

**Parcel, Nonconforming.** A legally created parcel which does not conform with current standards for area, width, frontage or other such standards for the zone in which the parcel is located because of annexation or amendments to the title.

**Park and Recreational Area, Public.** Include playgrounds, public gardens, outdoor sports grounds, indoor sports structures within a park area, tot lots, passive park areas, and other areas of use to the general public for recreation or outdoor diversions, not including commercial recreation facilities (see "Commercial Recreation Facility.")

**Parking Driveway Width.** The horizontal measurement of an access driveway to a parking area, measured perpendicular to the direction of travel.

**Parkway.** That portion of a public right-of-way located between the outermost curb-lane driving lane and the farthest edge of the right-of-way.

**Passageway.** A pathway unobstructed clear to the sky and extends from a street to one entrance of the accessory dwelling unit.

**Passive Recreation.** See "Recreation, Passive."

**Path of Travel.** A continuous, unobstructed way of pedestrian passage.

**Patio Cover.** A one story, roofed structure, not more than 12 feet in height above adjacent finished grade, used only for recreational and/or outdoor living purposes, that may be attached or detached as an accessory structure to the primary building.

**Pedestrian Shed.** An area centered on a destination including, but not limited to, a civic space, civic building, or main street. Its size is limited by an average distance that may be traversed at an easy walking pace in a given amount of time from its center to its edge, about 1,500 feet. Pedestrian sheds are used for planning Walkable Urban areas.

**Pedestrian Orientation.** A physical structure or place with design qualities and elements that contribute to an active, inviting, and pleasant place for pedestrians that typically includes most of the following elements:

1. Building facades that are highly articulated at the street level, with interesting uses of material, color, and architectural detailing, located directly behind the sidewalk;
2. Visibility into buildings at the street level;
3. A continuous sidewalk, with a minimum of intrusions into pedestrian right-of-way;
4. Continuity of building facades along the street with few interruptions in the progression of buildings and stores;
5. Signs oriented and scaled to the pedestrian rather than the motorist; and/or
6. Pedestrian orientation may also include: design amenities related to the street level including, but not limited to, awnings, paseos, and arcades; landscaping and street furniture.

**Pedestrian-Oriented Businesses.** General commercial businesses that allow customers to park once and complete multiple transactions and visits on foot in a context that encourages people to walk instead of drive.

**Pediment.** A triangular space that forms the gable of a low-pitched roof and that is usually filled with relief sculpture in classical architecture.

**Pedestrian-Oriented Use.** A land use that is intended to encourage walk-in customers and that generally does not limit the number of customers by requiring appointments or otherwise excluding the general public. A pedestrian oriented use provides spontaneous draw from sidewalk and street due to visual interest, high customer turnover, and/or social interaction.

**Pennant.** Any lightweight flexible plastic, fabric, or other material, whether or not containing a message of any kind, suspended from a rope, wire, or string, in a series of three or more, designed to move in the wind.

**Personal Service Shops.** Establishments providing non-medical services to individuals as a primary use. Examples of these uses include: barber and beauty shops; garment pressing, repair, and alteration; laundering, dry cleaning, laundromats; cleaning pickup stations; shoe repair shops; printing, limited to letterpress and duplication machines; therapeutic massage; vending machines. These uses may also include accessory retail sales of products related to the services provided.

**Pharmacy.** Establishment that sells prescription drugs, over-the-counter medications, and other related products.

**Places of Assembly With Fixed Seating.** Gathering places furnished with permanent seating, including auditoriums, theaters, assembly hall, sports arenas, and stadiums.

**Places of Assembly Without Fixed Seating.** Gathering places not furnished with permanent seating, including dance clubs, exhibition halls, and gymnasiums.

**Planning Commission.** The Belvedere Planning Commission, referred to in this FBC as the Planning Commission.

**Plant Nursery Sales and Garden Supply.** Establishments engaged in the production and sale of ornamental plants and other garden products, grown under cover either in containers or in the soil on the site, or grown outdoors in containers. The outdoor production of ornamental plants in the soil on the site is instead included under "Agriculture."

**Plot Plan.** A plan for an individual residential design site within an approved subdivision. At a minimum, the plot plan shows the design site property lines with metes and bounds; street address; driveways; grading; proposed locations for structures; public and private improvements (e.g., utility service laterals); retaining walls; trees; and measurements to locate these improvements within the design site.

**Podium.** A continuous projecting base or pedestal under a building often occupied by parking.

**Podium Top.** A flat, elevated and open area above a podium that can be used as common area.

**Porch.** A covered shelter projecting in front of the entrance of a building.

1. **Porch, Engaged.** See Section 22.07.050 (Porch Engaged).
2. **Porch, Projecting.** See Section 22.07.040 (Porch Projecting).

**Pre-Development Grade.** The grade of a design site prior to any site improvements related to the proposed development.

**Premises.** An area of land with its appurtenances and buildings which because of its unity of use may be regarded as the smallest conveyable unit.

**Primary Building.** See "Building, Primary."

**Primary Living Space.** A space within the primary building that is designed as a living room, dining room, or bedroom.

**Printing and Processing.** Establishments engaged in heavy print shop, typesetting, lithograph, and silk screening (of printed materials only); graphics and art services; sign company; blueprinting; non-retail photographic processing and printing; and art services.

**Private Open Space.** The area required for each unit in some building types, provided as outdoor yard areas, patios, decks, and balconies, but excluding stairs, entrance decks, and/or landings. Does not include required setbacks.

**Private Street.** Any street not a public street.

**Private Swim Club and Recreation Center.** A private facility for swimming and other recreational activities. A swimming pool shall be any pool, pond, lake, or open tank located within or outside of a building and containing or normally capable of containing water to a depth at any point greater than one and one-half feet.

**Production, Artisanal.** Food and/or products made by hand in small batches that requires skills from a maker/master with a combination of science and art derived from experience.

**Pub.** A business where alcoholic beverages are sold for on-site consumption, which are not part of a larger restaurant. Includes bars, taverns, pubs, and similar establishments where any food service is subordinate to the sale of alcoholic beverages. May also include beer brewing as part of a microbrewery ("brew-pub"), and other beverage tasting facilities.

**Public Assembly.** A gathering of members of the public. See "Community Assembly."

**Public and Quasi-Public.** Includes public, semi-public, and private elementary schools; middle schools; high schools; civic buildings; community buildings and uses; and public utility uses including substations, governmental buildings, churches, museums, art galleries, fire stations, post offices, police stations, reservoirs, libraries, parks, essential services, hospitals, and similar uses, any of which may have additional standards to use set forth herein.



**Public Safety Building.** Buildings for public utility uses including substations, fire stations, police stations, hospitals, and similar uses.

**Public Property.** Any property publicly owned outside of the designated public right-of-way.

**Public Street.** A street for which the right-of-way is owned by or offered for dedication to the public and accepted by the City.

**Public Use.** A use undertaken by a political subdivision.

#### Q. Definitions

*No specialized terms beginning with the letter Q are defined at this time.*

#### R. Definitions

**Rake.** The sloped end portion of a roof. Rakes may be close to, or extend from the building to allow for an overhang. Roof rakes can be exposed or closed.

**Rear.** Opposite of front.

**Rear-Loaded (syn. Rear Access).** Vehicular access from the rear of the design site.

**Recessed Entry.** An entrance to a building that is set back from the facade of the building.

**Reclassification of Land.** An amendment to this Title, which changes the classification of any property from one zone to another zone provided for in compliance with this Title.

**Recreation, Active.** Recreational pursuits usually performed with others and often requiring equipment which required physical alteration to the area in which they are performed. Such areas are intensively used, and include but are not limited to playgrounds; sport courts; baseball/softball and other field sports; and swimming pools.

**Recreational Area.** Areas of active play or recreation including, but not limited to, sports fields, school yards, picnic grounds, or other areas with intense foot traffic.

**Recreation, Indoor.** Establishments providing indoor amusement and entertainment services for a fee or admission charge (e.g., bowling alleys, card rooms, coin-operated amusement arcades, dance halls, electronic game arcades, ice or roller skating, pool and billiard rooms, etc.).

**Recreation, Passive.** Recreational pursuits involving existing natural resources which can be carried out with little alteration or disruption to the area in which they are performed. This includes, but is not limited to such activities as walking; hiking; bicycling; bird and animal watching; and picnicking.

**Recreation, Commercial.** Recreation facilities operated as a business and open to the general public for a fee.

**Recreation, Private, Noncommercial.** Recreation facilities operated by a nonprofit organization and open only to bona fide members of such nonprofit organization.

**Relocation.** The act or process of moving a structure or object from one property to another property or to a different location on the same property.

**Renovation**

1. A structural change to the foundation, roof, floor, or exterior of load-bearing walls of a facility, or the extension of an existing facility to increase its floor area.
2. Alteration of an existing facility including, but not limited to, significantly changing its function, even if such renovation does not include any structural change to the facility.
3. Remodeling of the building interior or exterior.

**Rental Shops - Consumer Goods.** Consumer-oriented rental shops including party furnishings; household tools and appliances; consumer-scale garden equipment; auto-related equipment; etc. Includes vending machine service. Does not include construction equipment rental.

**Repair Service - Equipment, Appliances, etc.** Miscellaneous repair services including only:

1. Business equipment and furnishings repair and service;
2. Household yard equipment and appliance repair and service; and
3. Audio, video and computer repair, and service.

**Research and Development Facility.** A facility for scientific research, and the design, development, and testing of electrical, electronic, magnetic, optical, and computer and telecommunications components in advance of product manufacturing; and the assembly of related products from parts produced off-site, where the manufacturing activity is secondary to the research and development activities. Includes pharmaceutical, chemical, and biotechnology research and development. Does not include laboratories for the testing of soil and other materials. See "Laboratory."

**Residential.** Premises used primarily for human habitation.

**Residential Development.** Any development that consists entirely of dwellings.

**Restaurant, Cafe, or Coffee Shop.** Any room, building, place, or portion thereof intended to provide seated and/or take-out service of food selections prepared on the premises; typically appropriate for a complete breakfast, lunch, or dinner meal; but excluding bakeries, specialty coffee, and similar retail establishments providing incidental seating/table accommodations for the convenience of the retail customer. Does not include fast-food or drive-in facilities. See "Restaurant, Fast Food" and "Drive-in Business."

**Restaurant, Fast Food.** A restaurant with a drive-through facility providing food service directly to occupants of a motor vehicle.

**Review Authority.** The individual or official City body (Director of Planning and Building, Planning Commission, or Belvedere City Council) identified by this FBC as having the responsibility and authority to review, and approve or deny the permit applications described in Chapter 10 (Administration).

**Right-of-Way (ROW).** Land dedicated to transportation purposes and/or use by the general public.

**Roadside Service Establishment.** Service stations, garages, restaurants, motels, hotels, and similar enterprises which provide food, shelter, or necessary automotive services or supplies to travelers.

**Rooming and/or Boarding.** A dwelling or part thereof other than a hotel where meals and/or lodgings are provided, for compensation, for six or more persons unless otherwise specified, not transients.

**Rowhouse.** See Section 22.06.100 (Neighborhood Townhouse).

**Runoff.** Water which is not absorbed by the soil to which it is applied. Runoff usually occurs when water is applied at too great a precipitation rate, when water is applied to saturated soils, or when water is applied to a steep slope.

## S. Definitions

**Sales Floor Area.** The interior building space devoted to the sale of merchandise. Does not include rest rooms, office space, storage space, automobile service areas, or open-air garden sales space.

**Satellite Dish Antenna.** Parabolic or spherical antenna whose purpose is to receive and/or transmit radio communication signals to and/or from satellites.

**Scenic Easement or Open Space Easement.** An easement granted to the public whereby the owner relinquishes or limits the right to construct improvements on the land.

**School.** Public-supported, private, and parochial institutions conducting regular academic instructions at preschool, kindergarten, elementary, secondary, and collegiate levels. Includes the following facilities.

1. **School, Elementary/ Middle/ Secondary.** A public or private academic educational institution, including elementary (kindergarten through 6th grade); middle and junior high schools (7th and 8th grades); secondary and high schools (9th through 12th grades). May also include any of these schools that also provide room and board.
2. **School, Specialty.** A school that provides education or training, including vocational training, in limited subjects. Examples of these schools include:
  - a. Art school;
  - b. Ballet and other dance school;
  - c. Business, secretarial, and vocational school;
  - d. Computers and electronics school;
  - e. Drama school;
  - f. Driver education school;
  - g. Establishments providing courses by mail;
  - h. Language school;
  - i. Martial arts;
  - j. Music school;
  - k. Professional school (law, medicine, etc.); and
  - l. Seminaries/religious ministry training facility.

Does not include pre-schools and child day care facilities. See also the definition of "Studio - Art, Dance, Martial Arts, Music, etc." for smaller-scale facilities offering specialized instruction.

**Second Unit.** See "Dwelling, Second Unit."

**Semi-Public Use.** A use owned or operated by a non-profit organization, private institution, or foundation.

**Semi-Public Utility Building.** A building owned or operated by a non-profit organization, private institution, or foundation, and used to provide utility services to its members or those persons it serves.

**Service Entries.** Building access for service providers.

**Service Facilities.** On-site facilities that support grounds maintenance, landscaping, and minor repair service relative to a primary use.

**Setback.** The distance by which a structure, parking area, or other development feature is separated from a design site line, other structure, or development feature.

1. **Setback, Front.** An area extending across the full width of the design site between the front design site line and the primary structure.
2. **Setback, Rear.** An area extending the full width of the design site between a rear design site line and the primary structure.
3. **Setback, Side.** An area between a side design site line and the primary structure extending between the front and rear setback.

**Setback, Building.** The mandatory clear distance between a design site line and a building.

**Setback, Parking.** The mandatory clear distance between a design site line and parking.

**Setback, Non-Street Frontage.** Any side or rear setback not contiguous to a public right-of-way. Such setback shall be measured laterally from the nearest part of that portion of a primary building facing said side or rear setback toward the nearest point of the design site line.

**Shared Parking.** Any parking spaces assigned to more than one user, where different persons utilizing the spaces are unlikely to need the spaces at the same time of day.

**Shopfront.** See Section 22.07.100 (Shopfront).

**Shopfront Base.** A very low wall, that does not include glass, between the display window(s) of a shopfront and the adjacent sidewalk.

**Sidewalk.** A paved area along a street intended exclusively for pedestrian use and often installed between a street and design site frontages.

**Single-Loaded, Building.** A building containing dwellings and/or commercial units without common hallways for access to the dwellings and/or units.

**Site Plan.** A base sheet that includes the basic information that will appear on all plans including, but not limited to, natural features, roads, buildings, or other structures to remain on-site.

**Special Event.** A temporary use including, but not limited to, art and craft shows and exhibits; carnivals; circuses; fairs; farmers' markets; festivals; flea markets; food events; open-air theaters; outdoor entertainment or sporting events; promotional events; swap meets; and other similar temporary community and entertainment assembly uses. Special events do not include private non-commercial events or parties held at a residence or accessory uses including, but not limited to, garage sales or outdoor displays.

**Special Architectural Elements.** Church spires; belfried cupolas and domes; monuments; corner or entry towers on residential units; and other similar architectural elements.

**Specific Plan.** See California Government Code §65450-65457.

**Stealth Design.** The effect of integrating an element including, but not limited to, a cellular antenna into a building that results in the element not being visible from adjacent public sidewalks and open space.

**Street, Front.** Street located along the front design site line of a parcel.

**Street, Side.** Street located along a design site line of a parcel that is not along the front design site line.

**Stoop.** See Section 22.07.070 (Stoop).

**Storage.** Includes:

1. **Contractor Storage Yard.** Outdoor storage facilities operated by or on behalf of a contractor licensed by the State of California for storage of large equipment, vehicles, and/or other materials commonly used in the individual contractor's type of business. May also include truck terminals and buildings or structures for uses including, but not limited to, repair facilities. Does not include vehicle dismantling yards, scrap, and waste yards. May include an accessory office. A contractor's office located away from a storage facility is included in compliance with the definition of "Office - Business, Service."
2. **Outdoor.** The storage of various materials outside of a structure other than fencing, either as an accessory or primary use.
3. **Self-Storage Facility.** A structure containing generally small, individual compartments, stalls, or lockers rented as individual storage spaces and characterized by low parking demand.

**Storefront.** The majority portion of a shopfront frontage that consists of the display window and/or entrance and its components, including windows, doors, transoms, and sill pane.

**Story.** The portion of a building included between the surface of any floor and the surface of the next floor above it, or if there is no floor above, the space between the floor and the ceiling above. If the finished floor level directly above a basement or cellar is more than six feet above grade for more than 50 percent of the total perimeter, such basement or cellar shall be considered a story.

1. **Story, First.** The lowest story or the ground story of any building, the floor of which is not more than 12 inches below the average contact ground level at the exterior walls of the building.
2. **Story, Half (syn. Attic Story).** A conditioned space that rests primarily underneath the slope of the roof, usually having dormer windows. The half story is identified by the ".5" in the description of maximum height (e.g., 2.5). A half-story is considered a story when its top wall plates, on at least two opposite exterior walls, are four feet or more above the floor of such story.
3. **Story, Mezzanine.** A story which covers one-third or less of the area of the story directly underneath it. A mezzanine story shall be deemed a full story when it covers more than one-third of the area of the story directly underneath said mezzanine story.

**Street.** A public or permanent private thoroughfare which affords a primary means of access to design site(s).

1. **Street, Front.** Street located along the front design site line.
2. **Street, Side.** Street located along a design site line that is not the front design site line

**Street Frontage.** The lineal length of that portion of a design site abutting a street.

**Street Frontage, Principal.** The length of the property line of any one premise parallel to and along the public right-of-way which it borders and which is identified by an officially assigned street address.

**Street Tree.** A tree planted in open spaces, parkways, sidewalk areas, easements, streets, and rights-of-way.

**Studio - Photography, Art, Martial Arts, Music, etc.** A small-scale facility, typically accommodating one group of students at a time, in no more than one instructional space. Larger facilities are included under the definition of "Schools - Specialty." Examples of these facilities include: individual and group instruction and training in the arts, martial arts, music, and photography; and the processing of photographs produced only by users of the studio facilities. Also includes production studios for individual painters, sculptors, photographers, and other artists.

**Supportive Housing.** See "Transitional Housing."

**Swimming Pool, Public or Private.** Any pool, pond, lake or open tank located within or outside of a building, and containing or normally capable of containing water to a depth at any point greater than 1.5 feet.

## T. Definitions

**Tandem Parking.** A parking space deep enough to allow two cars to park, one behind the other.

**Tavern.** See "Pub."

**Terrace.** See Section 22.07.110 (Terrace).

**Theater, Cinema or Performing Arts.** An indoor facility for group entertainment, other than sporting events. Examples of these facilities include: civic theaters, facilities for live theater and concerts, and movie theaters.

**Thoroughfares.** A way for use by vehicular, pedestrian, and bicycle traffic that provides access to design sites and open spaces, and that incorporates vehicular lanes and public frontages.

**Townhouse, Neighborhood.** See Section 22.06.100 (Neighborhood Townhouse).

**Transect.** A cross-section of the environment showing a range of different habitats. The Natural-to-Urban Transect of the human environment is divided into multiple transect zones that describe the physical form and character of a place according to the intensity of its land use and urbanism. See Table P-1E-B (Summary Table of Transects for Natural, Rural, and Walkable Contexts in Belvedere).

**Transect Zone.** See "Form-Based Zone."

**Transitional Housing.** Rental housing operated in compliance with program standards that call for the termination of assistance and recirculation of the assisted unit to another eligible program recipient at some predetermined future point in time, which shall be no less than six months. Includes supportive housing, shelters housing, and single room occupancy hotels and shelter housing.

**Transit Station.** A design site or structure used for the purpose of parking, loading, and unloading freight and passengers from train or bus transportation. May include parking facilities and other commercial amenities to service transit passengers.

**Transit Stop.** A location where buses stop to load and unload passengers. A transit stop may or may not include a shelter or a pullout.

**Transom.** Refers to a window; a window above a door or other window built on and commonly hinged to a transom

**Tripartite.** A method of visually organizing a facade of the building by dividing it up into three sections: the base, middle, and top.

**Turf.** A surface layer of earth containing mowed grass with its roots. Annual bluegrass, Kentucky bluegrass, perennial ryegrass, red fescue, and tall fescue are cool-season grasses. Bermudagrass, kikuyugrass, seashore paspalum, St. Augustinegrass, zoysiagrass, and buffalo grass are warm-season grasses.

**TV and Radio Stations.** Commercial and public communications facilities entirely within buildings, including radio and television broadcasting, and receiving stations and studios.

## U. Definitions

**Understory.** The smaller trees and shrubs below the canopy of large trees.

**Unit.** See "Dwelling Unit."

**Upper Floor.** A floor in a building containing habitable space that is located above the ground floor.

**Urban Agriculture (Crop Production).** Areas in some form of cultivation including, but not limited to, row crops, orchards, or greenhouses that support nearby or on-site food establishment operations.

**Usable Open Space.** Common or private open space, excluding the following:

1. Required front setbacks;
2. Areas devoted to parking, driveways, and maneuvering areas;
3. Open space at grade less than 10 feet in its minimum dimension; and
4. Patios, balconies, or decks less than five feet in their minimum dimension.

**Use.** The purpose for which land, premises, or structure thereon is designed, arranged, or intended, or for which it is or may be occupied or used.

**Use, Accessory.** A subordinate use of a building, structure, or design site that is customarily incidental to a principal use located on the same parcel.

**Use, Principal.** The main or primary use or uses conducted on a design site or located within a building or within a portion of a building which is separated structurally from other uses within the same building, not to include an accessory use as defined herein or a subordinate department of a main or primary use.

**Use, Temporary.** The use of land or premises or a building thereon for a limited period of time which does not change the character of the site, premises, or uses therein.



## V. Definitions

### Vehicle Services.

1. **Vehicle Services, Auto Repair Garage.** Auto service for general repair, rebuilding, or reconditioning of engines, motor vehicles or trailers; towing service; collision service including body or frame, straightening, repair, or overall painting; or paint shop. Includes businesses dealing in used parts; auto wrecking and salvage; and tire recapping establishments.
2. **Vehicle Services, Auto Service Center.** Vehicle services in conjunction with a department store or as part of a shopping center or mall development.

**Veterinary Clinic, Animal Hospital.** Office and indoor medical treatment facilities used by veterinarians, including large- and small-animal veterinary clinics and animal hospitals.

**Visitability.** A basic level of accessibility that enables persons with disabilities to visit others in their dwellings by providing at least one accessible means of egress/ingress for each residential unit.

## W. Definitions

**Walkable Neighborhood Center.** A Walkable Urban environment that provides a concentrated mix of civic, institutional, and/or commercial uses.

**Walkable Neighborhood Plan (WNP).** A development plan for creating Walkable Urban environments with a mix of housing, civic, retail, and service choices within a compact, walkable, and transit-ready environment. See Section 22.09.030 (Walkable Neighborhood Plan).

**Walkable/Walkability.** The condition when an area is highly interconnected to other areas and appeals to pedestrians for recreational walking or for walking to work, transit, errands, shopping, or restaurants.

**Walkway.** A paved way located on one or more design sites, used for pedestrian traffic, and used exclusively by the design site owner(s), their guests, and invitees.

**Wall Plane.** A vertical surface defined by the facades of buildings.

**Warehousing and Distribution Facility.** An establishment engaged in selling merchandise to retailers; to contractors, industrial, commercial, institutional, farm, or professional business users; to other wholesalers; or acting as agents or brokers in buying merchandise for or selling merchandise to such persons or companies. Examples of these establishments include: Agents, merchandise or commodity brokers, and commission merchants; assemblers, buyers, and associations engaged in the cooperative marketing of farm products; merchant wholesalers; and stores primarily selling electrical, plumbing, heating, and air conditioning supplies and equipment. Also includes storage, processing, packaging, and shipping facilities for mail order and electronic commerce retail establishments.

**Water Table, Architectural Feature.** A horizontal projecting string-course of masonry, molding, or a ledge placed so as to divert rainwater from a building.

**Width-to-Height Ratio.** The ratio of the horizontal size of a space measured perpendicularly to the vertical height of a building.

**Winery.**

1. **Boutique.** Winery of 100 to 5,000 cases, including indoor retail sales of processed products produced on-site and related products provided the retail sales portion shall not exceed 20 percent of the facilities building area.
2. **Small.** Winery producing 5,000 to 10,000 cases on design sites greater than 10 acres.
3. **Large.** Wineries larger than a boutique and small winery, including indoor retail sales of processed products produced on-site and related products, provided the retail sales do not exceed a maximum of 20 percent of the building area. Includes winery related uses, including on-site food preparation and sales; restaurant or delicatessen; non-wine-related retail sales; and outdoor facilities for commercial food service or entertainment.

**Wing.** A structure of at least five feet in depth physically attached to, and secondary to, the main body of a primary building.

**X. Definitions**

*No specialized terms beginning with the letter Y are defined at this time.*

**Y. Definitions**

**Yard.** See "Setback."

**Z. Definitions**

**Zero Design Site Line.** A building or structure that is placed on the property line.

**Zone.** See "Transect Zone."

**Zone Map.** The zoning map(s) of the City of Belvedere, California, together with all amendments.

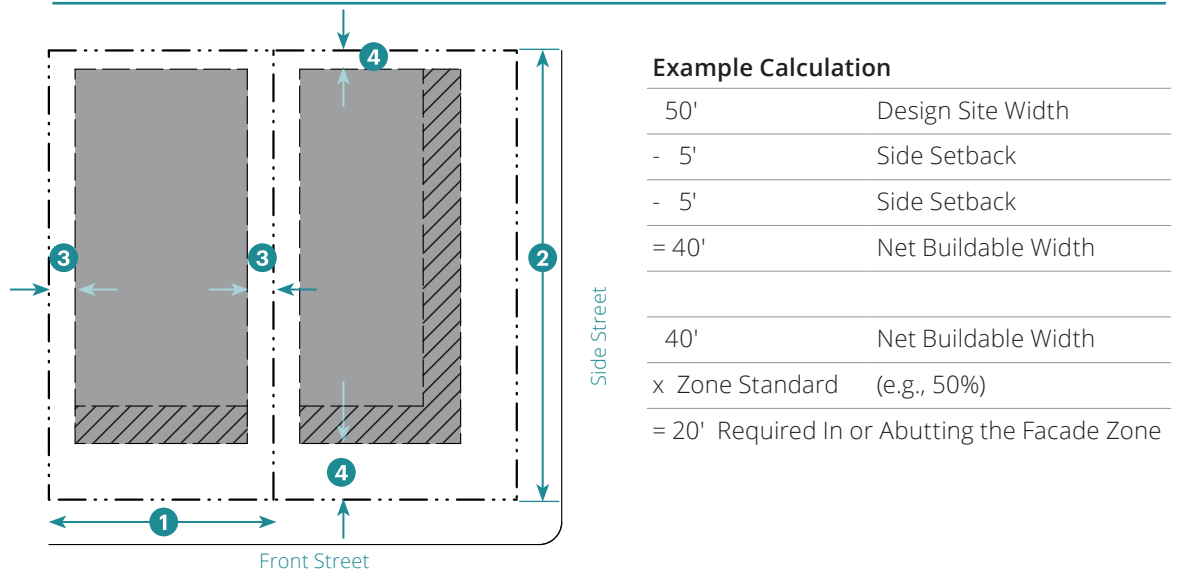
**Zoning Code.** The Zoning Ordinance of the City of Belvedere specified in Title 22 (Objective Design and Development Standards).

**22.11.030 Measurement Methods**

**1. Primary Building within Facade Zone**

- A. **Applicability.** The facade zone standards apply to new primary buildings and their additions along the front and side street of a design site.
- B. **Methodology.** The required amount is expressed in the zone standards as a percentage. The percentage is calculated as follows through an example for the front facade zone. The same approach is to be applied to the side street, using the minimum front and rear building setbacks.
  - (1) Identify the width of design site (e.g., 50 feet) and apply required front and side building setbacks (e.g., 5 feet and 5 feet).
  - (2) Subtract the horizontal length between each side setback and the adjacent side design site line from the total width of the design site. The result is the net buildable width of the design site (e.g., 40 feet).
  - (3) Multiply the required minimum percentage in the zone standards (e.g., 50 percent) by the net buildable width of the design site (e.g., 50 feet).
  - (4) The result is the minimum length, in feet, of building facade that shall be placed in or abutting the facade zone (e.g., 20 feet).
  - (5) See Figure 2 (Applying the Required Amount to the Facade Zone) for examples that are consistent with the intent of this standard.

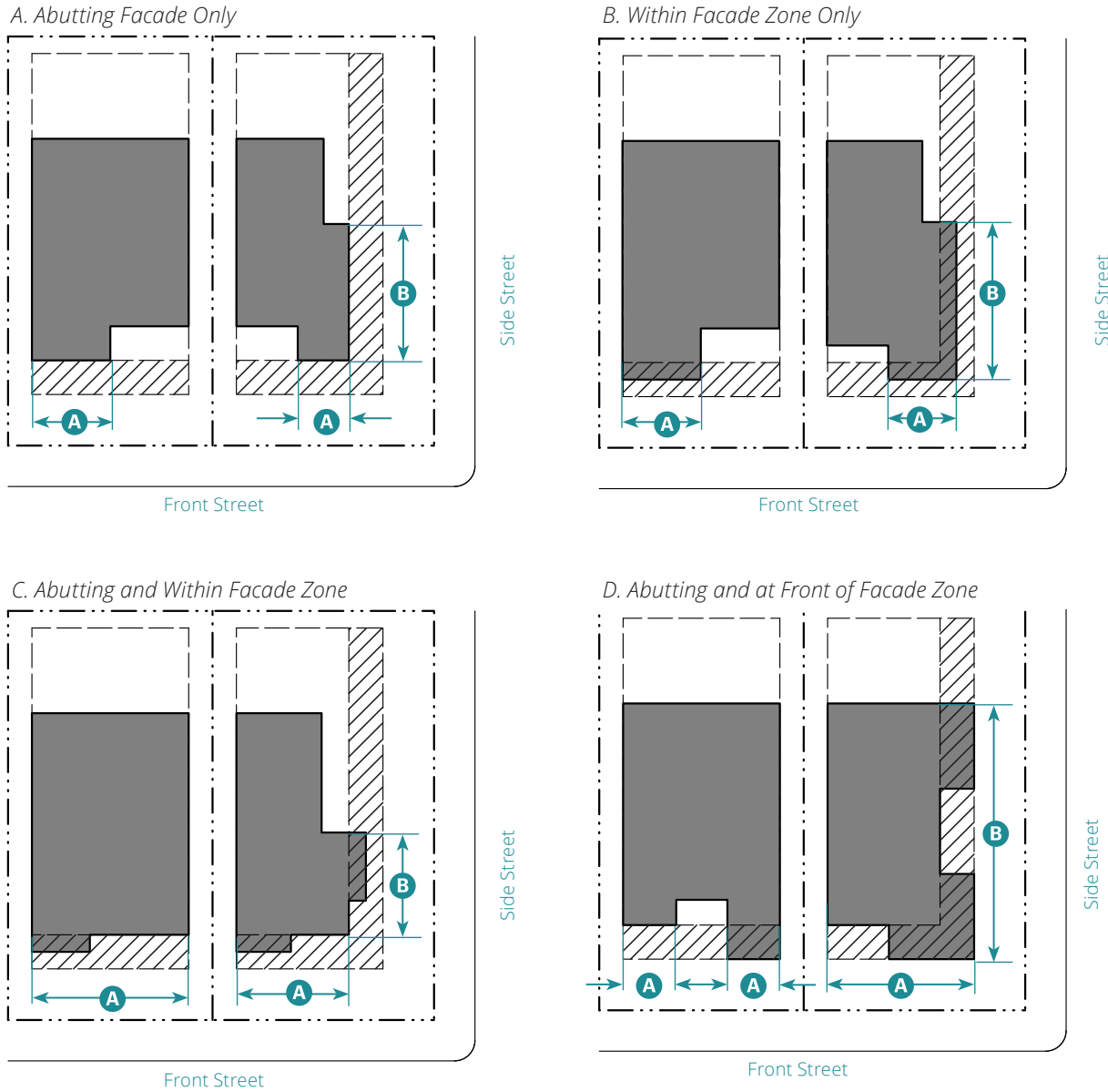
**Figure 22.11.030.1: Determining the Required Amount Subject to the Facade Zone**



**Key**

- ① Width of Design Site
- ② Depth of Design Site
- ③ Setback to be Subtracted from Design Site Width
- ④ Setback to be Subtracted from Design Site Depth

**Figure 22.11.030.2: Applying the Required Amount to the Facade Zone**



**Key**

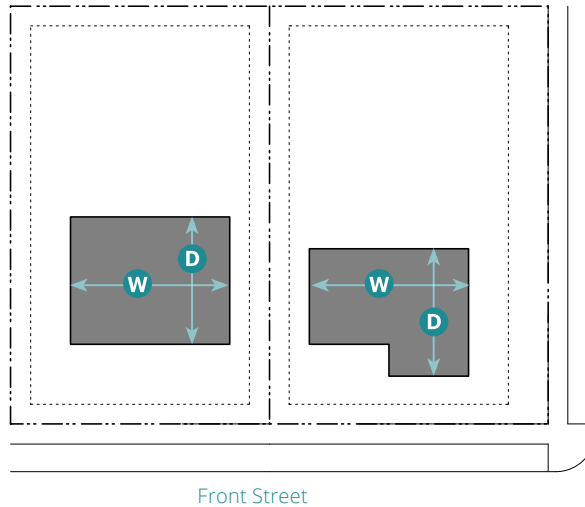
	Front Street	Side Street
///	Facade Zone 50% min. <sup>1</sup>	50% min. <sup>1</sup>
■	Buildable Area <b>A</b>	<b>B</b>

<sup>1</sup>This is an example. See Subsection 5 of the zone for the standard.

2. **Measuring Building Types**

A. **Methodology.** Measurement of width and depth

- (1) **Main Body.** The width and depth of the main body shall be measured as follows:
  - (a) The width shall be parallel to the front.
  - (b) The depth shall be perpendicular to the front.

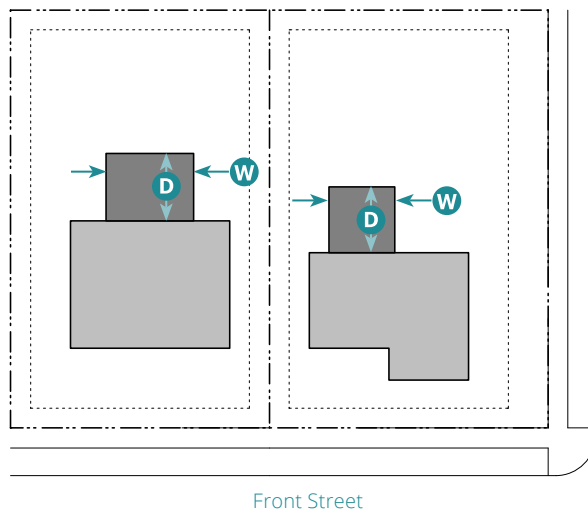


**Figure 22.11.030.3:**  
**Main Body**

**Key**

- W** Width
- D** Depth

- (2) **Wings and Ancillary Structures.** The width and depth of wings and ancillary structures, shall be measured as follows:
  - (a) The width shall be the greater of the two dimensions of the footprint.
  - (b) The depth shall be the lesser of the two dimensions of the footprint.

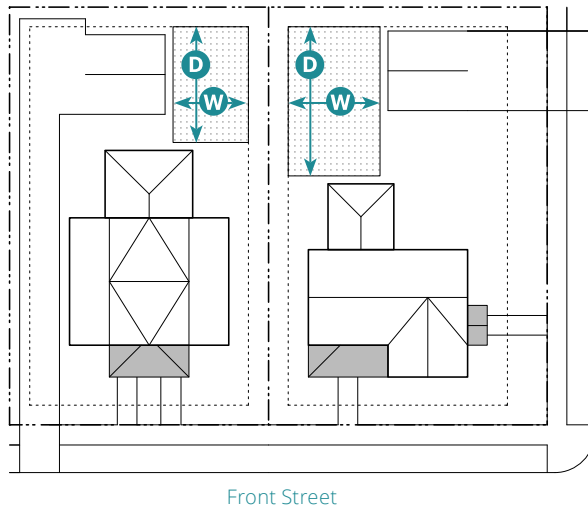


**Figure 22.11.030.4:**  
**Wings and Ancillary Structures**

**Key**

- W** Width
- D** Depth

- (3) **Open Space(s).** The width and depth of open spaces shall be measured as follows:
  - (a) The width shall be parallel to the front
  - (b) The depth shall be perpendicular to the front.



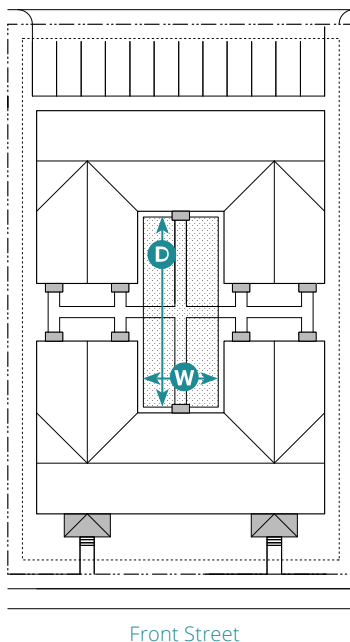
**Figure 22.11.030.5:  
Open Space(s)**

**Key**

- W** Width
- D** Depth

**Courtyard(s).** The width and depth of courtyards shall be measured as follows:

- (c) The width shall be parallel to the front; unless the courtyard is a secondary courtyard accessed directly from a side street.
- (d) If a secondary courtyard is accessed directly from the side street, the width shall be parallel to the side street.
- (e) The depth shall be perpendicular to the width.

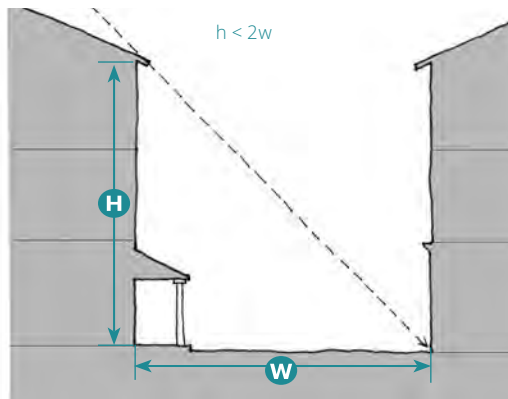


**Figure 22.11.030.6:  
Courtyard(s)**

**Key**

- W** Width
- D** Depth

- (4) **Width-to-Height Ratio.** Measurement of width-to-height ratio and depth-to-height ratio of forecourts.
- (a) The width and depth of forecourts shall be measured per Figure 7 (Width-to-Height Ratio).
  - (b) The height of forecourts shall be a measurement of the vertical plane of the building that defines the forecourt.



**Figure 22.11.030.7:**  
**Width-to-Height Ratio**

**Key**

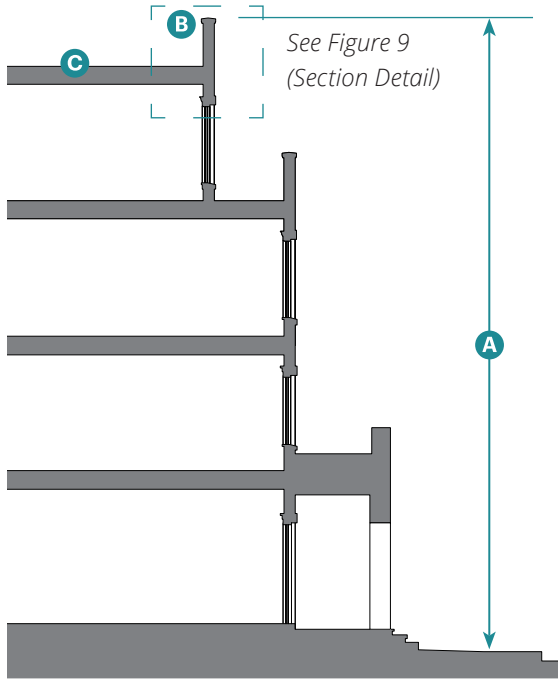
- W** Width
- H** Height



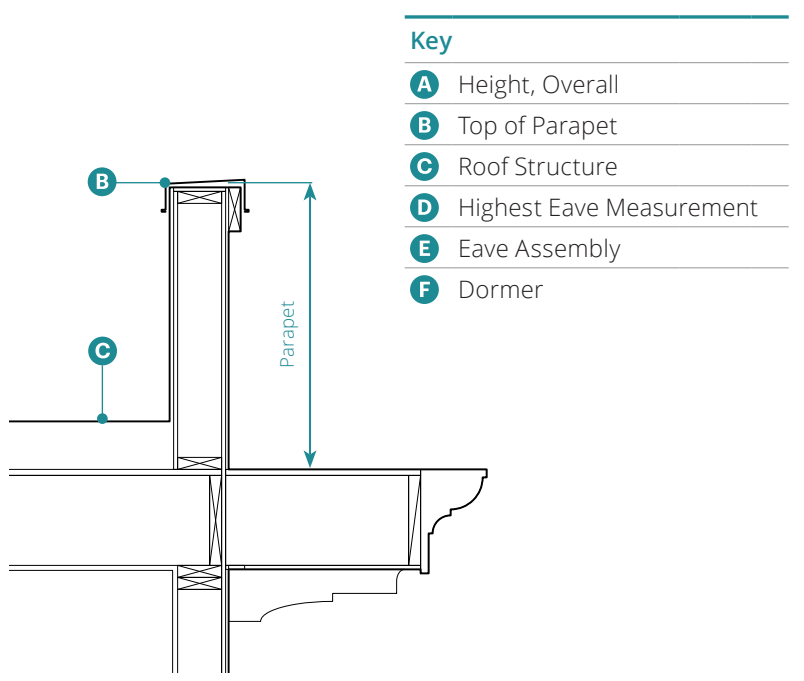
(5) **Highest Eave/Top of Parapet.**

- (a) **Height, Overall.** The vertical distance between adjacent finished grade and the highest part of the structure directly above.
- (b) **Height, Top of Parapet.** The vertical distance between adjacent finished grade and the top of the parapet of the primary building.
- (c) **Height, Highest Eave.** The vertical distance between adjacent finished grade and the highest eave of the primary building.
- (d) **Highest Eave Measurement.** The measurement is to bottom of the eave assembly.
- (e) **Eave.** The edge of the roof that overhangs the face of the adjoining wall. The bottom of the eave can range from exposed rafters to a finished horizontal surface.

**Figure 22.11.030.8: Top of Parapet and Flat Roof**



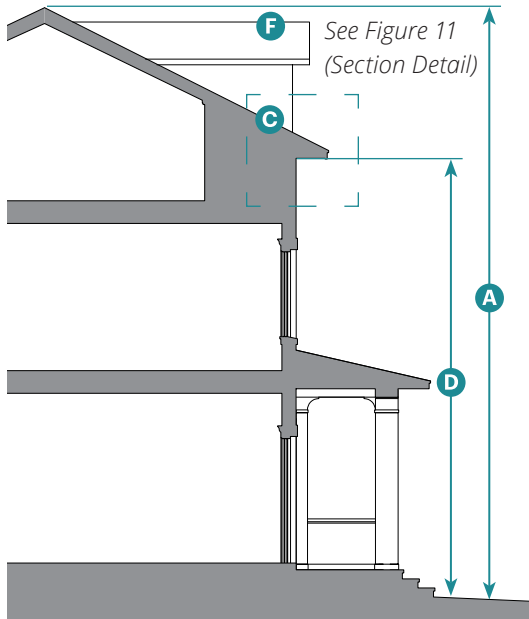
**Figure 22.11.030.9: Section Detail of Top of Parapet and Flat Roof**



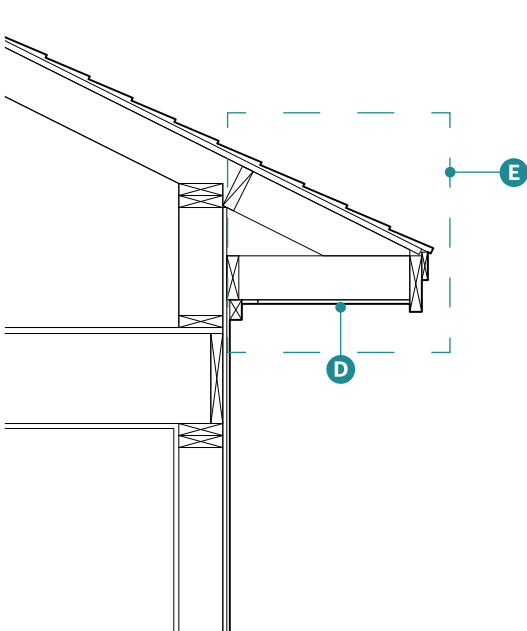
**Key**

- A** Height, Overall
- B** Top of Parapet
- C** Roof Structure
- D** Highest Eave Measurement
- E** Eave Assembly
- F** Dormer

**Figure 22.11.030.10: Highest Eave for Pitched Roof**

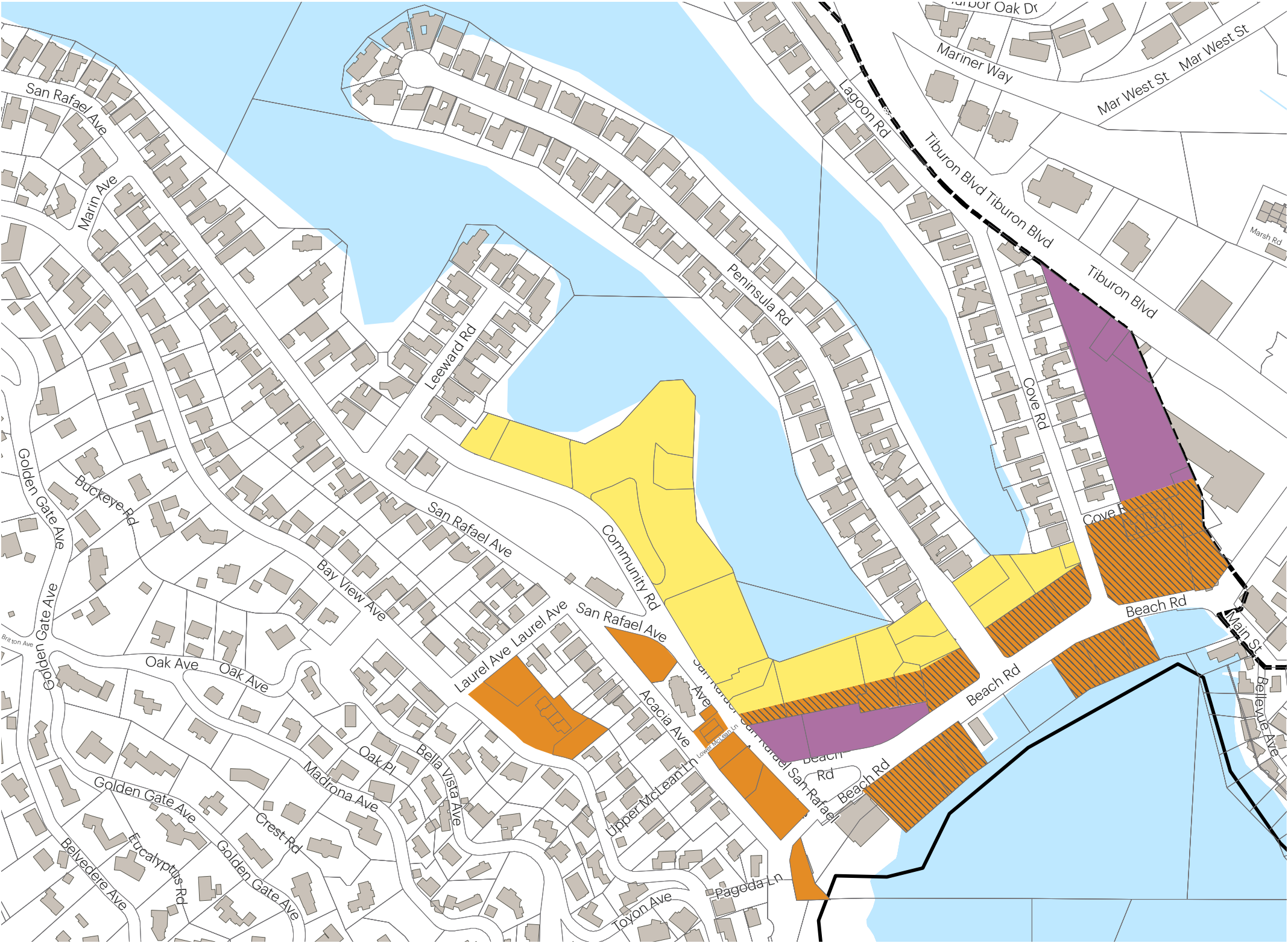


**Figure 22.11.030.11: Section Detail of Highest Eave for Pitched Roof**



*This page intentionally left blank*

# Belvedere Objective Design Standards Zones



Area	ODS Zones
	T3 Suburban Neighborhood
	T4 Suburban Neighborhood.Small
	T4 Suburban Main Street.Small
	Open Sub-zone

