

GENERAL NOTES:

- 1. THE DRAWINGS ARE INTENDED TO ONLY PARTIALLY DESCRIBE THE SCOPE OF WORK FOR THE PROJECT. ANY WORK NOT SHOWN HERE, BUT REQUIRED BY CODE, OR THE SPECIFICATIONS, OR TO MAKE THE WORK COMPLETE, SHALL BE PROVIDED AS PART OF THE WORK.
2. PROJECT SPECIFICATIONS AND SCOPE SHALL TAKE PRECEDENCE OVER THE DRAWN PLANS. IN THE CASE OF DISCREPANCY NOTIFY MAINVUE HOMES FOR CLARIFICATION. IT IS THE INTENT OF THE DOCUMENTS THAT ALL WORK COMPLIES WITH THE INTERNATIONAL RESIDENTIAL CODE, INTERNATIONAL MECHANICAL CODE, INTERNATIONAL ELECTRICAL CODE, INTERNATIONAL ENERGY CODE, INTERNATIONAL FIRE CODE, AND ALL APPLICABLE LOCAL, STATE, AND NATIONAL CODES AND ORDINANCES IN EFFECT AT THE DATE OF PERMIT SUBMITTAL. NOTHING IN THESE DRAWINGS SHALL BE CONSTRUED TO GRANT APPROVAL FOR ANY CODE VIOLATION. ANY ERRORS, OMISSIONS, OR NON-COMPLIANCE WITH GOVERNING CODES SHALL BE BROUGHT TO THE ATTENTION OF MAINVUE HOMES IMMEDIATELY.
4. BEFORE STARTING EACH PORTION OF THE WORK, SUBCONTRACTORS SHALL CAREFULLY STUDY AND COMPARE THE VARIOUS DRAWINGS AND OTHER CONTRACT DOCUMENTS RELATED TO THAT PORTION OF THE WORK, SHALL TAKE FIELD MEASUREMENTS OF ANY EXISTING CONDITIONS RELATED TO THAT PORTION OF THE WORK AND SHALL OBSERVE ANY CONDITIONS AT THE SITE AFFECTING IT. ANY ERRORS, INCONSISTENCIES OR OMISSIONS SHALL BE REPORTED PROMPTLY TO MAINVUE HOMES.
5. DO NOT SCALE THE DRAWINGS. SUBCONTRACTORS SHALL USE DIMENSIONS SHOWN ON THE DRAWINGS AND ACTUAL FIELD MEASUREMENTS. IF DISCREPANCIES ARE FOUND, MAINVUE HOMES SHALL BE NOTIFIED AT ONCE.
6. DIMENSIONS ARE SHOWN TO THE FACE OF FRAMING, FACE OF FRAMING AT EXTERIOR AND INTERIOR WALLS AND FACE OF FRAMING OF ROUGH OPENINGS, UNLESS DETAILED OR NOTED OTHERWISE. REFER TO MAINVUE HOMES IF CLARIFICATION IS NEEDED.
7. REPETITIVE FEATURES NOT INDICATED IN THE DRAWINGS EVERYWHERE THEY OCCUR SHALL BE PROVIDED AS IF DRAWN IN FULL.
8. THE CONTRACT DOCUMENTS ARE COMPLEMENTARY, AND WHAT IS REQUIRED BY ONE SHALL BE AS BINDING AS IF REQUIRED BY ALL. IN CASE OF DISCREPANCY, REFER TO MAINVUE HOMES FOR CLARIFICATION.
9. WORK SHOWN ON THE DRAWINGS IS INTENDED TO ILLUSTRATE THE GENERAL DESIGN INTENT, SCOPE, AND LOCATION OF WORK. ALL WORK NOT SPECIFICALLY DRAWN, BUT REQUIRED FOR A COMPLETE, LEGAL, AND FUNCTIONING SYSTEM, SHALL BE PROVIDED AS PART OF THE WORK.

GENERAL CODE COMPLIANCE NOTES:

ASSUMED DESIGN LOADS

ALL ASSUMED DESIGN LOADS ARE PER 2018 INTERNATIONAL BUILDING CODE (UNLESS NOTED BY ENGINEER)

Table with 2 columns: Load Type and Value. Includes Uniform Snow Load (25 PSF), Seismic Zone Category (D), Weathering (Moderate), Frost Line Depth (18"), Termites Infestation Risk (Slight to Moderate), Risk of Decay (Slight to Moderate), Winter Design Temperature (22° F), Flood Hazard Index (May 12, 1974 - Amended Nov 9 1999), Air Freezing Index (250), Mean Annual Temperature (51° F).

ANCHORED MASONRY VENEER:

MASONRY UNITS (5 INCHES MAX. IN THICKNESS) AND MASONRY VENEER NOT EXCEEDING 5 INCHES IN THICKNESS MAY BE ANCHORED DIRECTLY TO STRUCTURAL MASONRY, CONCRETE OR STUDS IN ONE OF THE FOLLOWING MANNERS:

- 1. ANCHOR TIES SHALL BE CORROSION RESISTANT, AND IF MADE OF SHEET METAL, SHALL HAVE A MINIMUM SIZE OF NO. 22 GAUGE BY 1 INCH OR, IF OF WIRE, SHALL BE A MINIMUM OF NO. 4 GAUGE. ANCHOR TIES SHALL BE SPACED AS TO SUPPORT NOT MORE THAN 2 SQUARE FEET OF WALL AREA BUT NOT MORE THAN 24 INCHES ON CENTER HORIZONTALLY. ANCHOR TIES SHALL BE PROVIDED TO HORIZONTAL JOINT REINFORCEMENT WIRE NO. 4 GAUGE OR EQUIVALENT. THE JOINT REINFORCEMENT SHALL BE CONTINUOUS WITH BUTT SPLICES BETWEEN TIES PERMITTED.
2. WHEN APPLIED OVER STUD CONSTRUCTION, THE STUDS SHALL BE SPACED A MAXIMUM OF 16 INCHES ON CENTERS AND APPROVED PAPER SHALL FIRST BE APPLIED OVER THE SHEATHING OR WIRE BETWEEN STUDS EXCEPT AS OTHERWISE PROVIDED IN THE I.R.C., AND MORTAR SHALL BE SLUSHED INTO THE SPACE BETWEEN FACING AND PAPER.
3. AS AN ALTERNATE, AN AIR SPACE OF AT LEAST 1/4 INCH MAY BE MAINTAINED BETWEEN THE BACKING AND VENEER IN WHICH CASE TEMPORARY SPOT BEDDING MAY BE USED AWAY FROM THE TIES TO ALIGN THE VENEER. SPOT BEDDING AT THE TIES SHALL BE OF CEMENT MORTAR ENTIRELY SURROUNDING THE TIES.

PLUMBING | MECHANICAL | ELECTRICAL INSTALLATION

ALL PLUMBING, MECHANICAL AND ELECTRICAL PERMITS SHALL BE OBTAINED SEPARATELY FROM THE BUILDING PERMIT AS NECESSARY AND SHALL BE APPLIED FOR BY THE APPROPRIATELY LICENSED SUBCONTRACTOR DIRECTLY.

THE MAXIMUM HOT WATER TEMPERATURE DISCHARGING FROM THE BATH TUB AND WHIRLPOOL BATH TUB FILLER SHALL BE LIMITED TO 120° FAHRENHEIT. THE WATER HEATER THERMOSTAT SHALL NOT BE CONSIDERED A CONTROL FOR MEETING THIS PROVISION PER UPC 408.3

GAS-FIRED FURNACES INSTALLED WITHIN THE INTERIOR THERMAL ENVELOPE SHALL BE DIRECT-VENTED OR 92% EFFICIENT, UNLESS INSTALLED IN A ROOM OR SPACE THAT OPENS ONLY INTO A BEDROOM OR BATHROOM, AND SUCH ROOM OR SPACE IS USED FOR NO OTHER PURPOSE AND IS PROVIDED WITH A SOLID WEATHER-STRIPPED DOOR EQUIPPED WITH AN APPROVED SELF-CLOSING DEVICE PER IRC 62406.2. ALL COMBUSTION AIR SHALL BE TAKEN DIRECTLY FROM THE OUTDOORS IN ACCORDANCE WITH SECTION 62407.6, AND SAID ROOM OR SPACE SHALL BE INSULATED PER MEEC.

BLUE 18 AWG TRACER WIRE REQUIRED AT NON-METAL WATER SERVICE PIPING PER UPC 604.10J

NO AIR ADMITTANCE VALVES TO BE INSTALLED IN LIEU OF UPC VENT TERMINATION REQUIREMENTS PER UPC 912J

AIR GAP AND YOLK VENT TO BE INSTALLED AT KITCHEN ISLAND SINK/DISHWASHER LOCATION IN ACCORDANCE WITH UPC 414.3.

GENERAL CODE COMPLIANCE NOTES (CONT.):

2018 IRC

BUILDING SEPARATION REQUIREMENTS (REFERENCE IRC R302)
ONE HOUR WALL IS REQUIRED IF LESS THAN 5' TO PROPERTY LINE. REFERENCE IRC TABLE R302.1 (I)
NO OPENINGS ALLOWED IN WALLS LESS THAN 3' TO PROPERTY LINE
EAVE OVERHANGS (REFERENCE IRC R302.1J)
REFER TO DETAIL 3/D1.0 AND THE EAVE SCHEDULE LOCATED ON A5.0

GARAGE / HOUSE REQUIREMENTS (REF. IRC R302.5 AND Table R302.6)
1/2" REGULAR GYP BOARD SHALL BE INSTALLED ON THE GARAGE SIDE AT WALLS SEPARATING GARAGE AND DWELLING
GARAGE CEILING WHERE DWELLING OCCURS ABOVE REQUIRES INSTALLATION OF 5/8" TYPE "X" GYPSUM BOARD. SUPPORTING STRUCTURE REQ. 1/2" REGULAR GYP BOARD.
DOOR (REF IRC R302.5J) 1-3/8" THICK MIN. SOLID CORE OR 20 MIN. DOOR SHALL BE INSTALLED BETWEEN GARAGE AND DWELLING.

BATHUB AND SHOWER SPACES (REF IRC R307.2)
TUB/SHOWER SURROUND WALLS TO HAVE FIBER-CEMENT BACKER BOARD AND FINISHED WITH A SMOOTH NON-ABSORBENT SURFACE TO A MINIMUM HEIGHT OF 12" ABOVE THE FLOOR. TILE SHOWER PANS ARE REQ'D TO HAVE WATER TEST ON PAN DRAIN PER UPC 408.15

SAFETY GLAZING (REF IRC R308.4)
ALL SIDE-LITES, SLIDING GLASS DOORS AND TUB/SHOWER ENCLOSURES TO COMPLY WITH 5.6. REQ'S.

SKYLIGHTS SHALL COMPLY WITH IRC R308.6

EGRESS WINDOWS (REF IRC R310)
REQUIRED TO BE LOCATED IN ALL BEDROOMS AND SHALL CONFORM TO THE FOLLOWING CRITERIA- MINIMUM NET CLEAR OPENING OF 5.7 SQFT. MIN NET CLEAR HEIGHT SHALL BE 24". MIN NET CLEAR WIDTH SHALL BE 20". MAX FINISHED SILL HEIGHT ABOVE FLOOR SHALL BE 44". WHERE THE SILL OF A WINDOW IS GREATER THAN 12" ABOVE FINISH GRADE OR OTHER SURFACE ON THE EXTERIOR OF THE BUILDING, MINIMUM SILL HEIGHT ABOVE FINISH FLOOR SHALL BE 24" OR BE PROVIDED WITH A WINDOW FALL PREVENTION DEVICE (REF IRC 312.2).

STAIRS (REF IRC R311.7)
BUILT MINIMUMS AND MAXIMUMS: MINIMUM WIDTH IS 36" MAX RISER IS 7-3/4" MIN TREAD RUN IS 10" MIN HEAD CLEARANCE IS 6'-8"
HANDRAIL SHALL BE INSTALL AT BETWEEN 34" TO 38" ABOVE TREAD NOSING. HANDRAIL GRASPING DIMENSION 1-1/4" MIN AND 2" MAX.

DECK / GUARDRAILS (REF IRC R312)
GUARD OR GUARD RAILS ARE REQUIRED FOR WALKING SURFACES 30" ABOVE ADJACENT GRADE OR FLOOR BELOW WITH MINIMUM INSTALLED HEIGHT OF 36" AND MAX OF 4" CLEAR SPACE BETWEEN INTERMEDIATE RAILS.

SMOKE ALARM (REF IRC R314)
MUST BE POWERED BY INTERCONNECTED BUILDING WIRING AND PROVIDED W/BATTERY BACKUP. REQUIRED IN ALL SLEEPING ROOMS, OUTSIDE SLEEPING AREAS IN IMMEDIATE VICINITY OF BEDROOMS, SMOKE ALARMS SHALL BE INSTALLED NOT LESS THAN 3' HORIZ FROM THE DOOR OR OPENING OF A BATHROOM THAT CONTAINS A BATHTUB OR SHOWER UNLESS THIS WOULD PREVENT PLACEMENT OF A SMOKE ALARM AS REQ'D BY SECTION R314.3, AND ON EACH ADDITIONAL STORY CONTAINING HABITABLE SPACE. ALARM MUST BE CLEARLY AUDIBLE IN ALL BEDROOMS.

HEAT DETECTOR/HEAT ALARM (REF IRC R314.2), R314.2.3)
A HEAT DETECTOR OR HEAT ALARM SHALL BE PROVIDED IN NEW ATTACHED GARAGES

CARBON MONOXIDE ALARM (REF IRC R315)
CO ALARM SHALL MEET UL LISTING 2034 COMBO CO-SMOKE ALARM SHALL ALSO MEET UL 217.

CO ALARM TO BE POWERED BY INTERCONNECTED BUILDING WIRING AND PROVIDED W/ BATTERY BACKUP AND INSTALLED PER MFG LISTING. TO BE PROVIDED OUTSIDE OF EACH SEPARATE SLEEPING AREA IN THE IMMEDIATE VICINITY OF THE BEDROOMS.

SITE ADDRESS (REF IRC R314)
BUILDING SHALL BE PROVIDED WITH APPROVED ADDRESS IDENTIFICATION WHERE SIZE AND LOCATION OF NUMBERS IS PER R314J

ROOF VENTILATION (REF IRC R306)
MIN NET FREE VENTILATION AREA SHALL BE 1/300 OF THE VENTED SPACE AND NOT MORE THAN 40% OR LESS THAN 50% OF THE REQ. VENTILATING AREA SHALL BE LOCATED IN THE UPPER PORTION OF THE ATTIC SPACE WITH THE BALANCE SUPPLIED BY EAVE OR CORNICE VENTS.
EAVE BAFFLES PROVIDING MIN 1" CLEARANCE SHALL BE PROVIDED FOR FREE FLOW OF AIR BETWEEN THE INSULATION AND THE ROOF SHEATHING AND THE LOCATION OF THE VENT. CROSS VENTILATION REQUIRED.

ATTIC ACCESS (REF IRC R307)
ATTIC AREAS WITH A VERTICAL HEIGHT OF 30" OR GREATER OVER AN AREA OF 30 S.F. MIN. HAVE HAVE AN ATTIC ACCESS OPENING MINIMUM OF 22" X 30"

GRAIL SPACE VENTILATION (REF IRC R408)
AN APPROVED CLASS I VAPOR RETARDER MATERIAL SHALL BE INSTALLED OVER THE GROUND SURFACE. MINIMUM NET AREA OF VENTILATION OPENINGS SHALL BE NOT LESS THAN 1 S.F. FOR EA 1500 S.F. OF UNDER FLOOR SPACE.
VENTILATION OPENINGS SHALL PROVIDE INSECT AND CORROSION PROTECTION WHERE THE LEAST DIM OF THE COVERING SHALL NOT EXCEED 1/4"
ONE SUCH VENTILATING OPENING SHALL BE WITHIN 3 FEET OF EACH CORNER OF THE BUILDING

MECHANICAL VENTILATION (RC M505)
KITCHENS, BATHROOMS AND LAUNDRY ROOMS SHALL BE SUPPLIED WITH MECHANICAL VENTILATION PER IRC TABLE M505.4
VENT DRYER, OVEN/RANGE AND EXHAUST FANS TO OUTSIDE. DRYER EXHAUST DUCTS SHALL NOT EXCEED A TOTAL COMB. HORIZ. AND VERT. LENGTH OF 35'-0" (REDUCE BY 5'-0" FOR EA 90 DEG ELBOW W/ 4" RADIUS OR 26" FOR EACH 45 DEG ELBOW W/ 4" RADIUS), INCL. TWO 90D. ELBOWS (4" RADIUS). DUCT 5'-0" FOR EA. 90D. ELBOW IN EXCESS OF TWO. ALL EXHAUST DUCTS TO BE INSULATED TO A MIN. OF R-4. ALL VENT TERMINATIONS MUST BE SCREENED W/ 1/4-1/2" METAL MESH.

FIRE AND DRAFT STOPS (REFERENCE IRC R302.1I AND R302.1J)
INSTALL DRAFT STOPS IN FLOOR-CEILING ASSEMBLIES SO THAT CONCEALED SPACE DOES NOT EXCEED 1,000 SQ. FT. FIRE BLOCKS SHALL BE PROVIDED TO CUT OFF ALL CONCEALED DRAFT OPENINGS FROM VERTICAL TO HORIZONTAL SPACES, INCLUDING THE STAIR, TUB, SHWR, FIREPLACE, BALLOON FRAMED WALLS, FURRED WALLS, VOIDS, SOFFITS ETC. PER R302.1I.

FACTORY BUILT FIREPLACE AND CHIMNEY TO BE UL LABELED, SEC.3102.5 UM 912 INSTALL PER MFR'S SPECS. OUTSIDE COMBUSTION AIR REQ'D. (MIN 6 SQ IN) DUCTED DIRECTLY TO FIREBOX W/ OPERABLE OUTSIDE DAMPER, TIGHTLY FITTING FLUE DAMPER AND TIGHT FITTING GLASS OR METAL DOORS OR FLUE DRAFT INDUCTION PAN.

ENERGY CODE REQUIREMENTS

2018 MEEC RESIDENTIAL PROVISIONS: PRESCRIPTIVE REQUIREMENTS (OPT. PER PLAN)

R401.3 A PERMANENT ENERGY COMPLIANCE CERTIFICATE SHALL BE POSTED ON A WALL IN THE SPACE WHERE THE FURNACE IS LOCATED, A UTILITY ROOM OR AN APPROVED LOCATION INSIDE THE BUILDING AND INCLUDE THE FOLLOWING: PREDOMINATE R-VALUES, U-VALUES OF PENETRATION, RESULTS FROM DUCT SYSTEM AND BUILDING ENVELOPE AIR LEAKAGE TESTING, AND EFFICIENCIES OF HTG/COOLING/WATER HEATING EQUIPMENT.

THE BUILDING THERMAL ENVELOPE, PER IRC N101.6, SHALL BE CONSTRUCTED TO BE COMPLIANT WITH MEEC TABLE R402.4.1J

AIR LEAKAGE TESTING (MEEC R402.4.1.2), THE DWELLING UNIT SHALL BE TESTED AND VERIFIED AS HAVING AN AIR LEAKAGE RATE OF NOT EXCEEDING 5 AIR CHANGES PER HOUR. TESTING SHALL BE CONDUCTED WITH A BLOWER DOOR AT A PRESSURE OF 0.2" w.g. (50 PASCALS). DUCTS MUST BE LEAK TESTED IN ACCORDANCE WITH (MSU RS-33) USING MAX DUCT LEAKAGE RATES SPECIFIED. TOTAL LEAKAGE OF THE DUCT SHALL BE MEASURED BY EITHER THE POST-CONSTRUCTION TEST OR ROUGH-IN TEST PER (MEEC R403.3.4) TOTAL LEAKAGE MUST BE LESS THAN OR EQUAL TO 4cfm PER 100 s.f. OF CONDITIONED FLOOR AREA WHEN TESTED AT A PRESSURE DIFFERENTIAL OF 0.1" w.g. (25 PA) ACROSS THE ENTIRE SYSTEM. ALL REGISTERS SHALL BE TAPED OR OTHERWISE SEALED DURING THE TEST. JOINTS AND SEAMS SHALL COMPLY WITH I.R.C. SECTION M610.4. THE AIR LEAKAGE TEST/ BLOWER DOOR TEST IS TO CONTAIN GPS MARKINGS WITH PHOTOS TO CERTIFY THE LOCATION OF THE TEST.

LIGHTING: AT LEAST 90% OF ALL LAMPS (INTERIOR AND EXTERIOR) IN PERMANENTLY INSTALLED LIGHTING FIXTURES SHALL BE HIGH-EFFICACY LAMPS. (MEEC 404.I), HIGH EFFICACY LAMPS ARE DEFINED AS, COMPACT FLUORESCENT LAMPS, T-8 OR SMALLER DIAMETER LINEAR FLUORESCENT LAMPS, OR LAMPS WITH A MINIMUM EFFICIENCY OF 60 LUMENS PER WATT FOR LAMPS OVER 40 WATTS, 50 LUMENS PER WATT FOR LAMPS OVER 15 WATTS AND UP TO 40 WATTS, 40 LUMENS PER WATT FOR LAMPS OF 15 WATTS OR LESS.

HOT WATER TANK SHALL BE LABELED PER ASHRAE STD. NO. 90A-80, MEET THE ENERGY PERFORMANCE REQ'NTS. OF THE 1987 NATIONAL APPLIANCE ENERGY CONSERVATION ACT AND MEEC R403.4.

LIMIT SHOWER FLOW TO 1.75 GALL/ MIN. LIMIT TOILETS TO 1.6 GAL/ FLUSH.

INSULATION AND PENETRATION REQUIREMENTS BY COMPONENT (TABLES R402.1I AND 402.1.3 AND 403.5.3 FOR PIPING)

Table with 2 columns: Component and Requirement. Fenestration U-Factor: 28 (ADJ. PER ENERGY CREDIT BELOW); Skylight U-Factor: 50

Table with 2 columns: Insulation Values and Requirement. Ceilings w/ Attics: R-44; Ceilings Vaulted - Scissor Trusses: R-44; Ceilings Vaulted - Single Rafter: R-38; Walls Above Grade (2x6): R-21 INT; Walls Below Grade (Interior): R-21 INT + T.B.; Walls Below Grade (Exterior): R-10; Floors w/ Unheated Space Below: R-38; Slab on Grade (Where Occurs): R-10, UNDER SLAB (ADJ. PER ENERGY CREDIT BELOW); Ext. Wall Headers: R-10 RIGID AT INSIDE FACE OF HEADER, WHERE HEADERS ARE NOT FULL WIDTH

Table with 2 columns: Mechanical Pipe Insulation and Requirement. Hot Water Pipe (All Locations): R-6 (WRAPPED); Hot Water Pipe (All Locations): R-3 (OK TO BE DISCONTINUOUS THROUGH STRICT. MEMBERS) PER 403.5.3)

2018 MEEC R406.3 - REQ'D CREDITS = 6.0
OPT. 2 (1.0 CREDITS) = HEATING OPTIONS - HEAT PUMP FOR SPACE HEATING
OPT. 1.3 (0.5 CREDITS) = ENERGY OPTIONS - EFFICIENT BUILDING ENVELOPE - UPGRADE WINDOWS TO 0.28 R-38 IN UNHEATED FLOORS AND R-10 UNDER SLAB
OPT. 3.5a (1.5 CREDITS) = ENERGY OPTIONS - SPACE HEATING USING FORCED-AIR DUCTED HEAT PUMP SYSTEM - 11.0 HEFF EFFICIENCY
OPT. 5.5 (2.0 CREDITS) = ENERGY OPTIONS - HYBRID HEAT PUMP TANK WATER HEATER TIER III (NO GAS LINE SHALL BE RUN TO THE LOCATION OF THE WATER HEATER)
OPT. 4.2 (1.0 CREDITS) = ENERGY OPTIONS - LOCATE FURNACE AND ALL DUCTWORK COMPLETELY WITHIN CONDITIONED SPACE THROUGH OPEN-WEB FLOOR SYSTEM

MOISTURE CONTROL

WALLS SEPARATING CONDITIONED SPACES FROM UNCONDITIONED SPACES SHALL HAVE A VAPOR RETARDER INSTALLED ON THE WARM SIDE OF THE WALL USING MIN CLASS II FLOOR RETARDER SUCH AS KRAFT FACED INSULATION.

SEAL, CAULK, GASKET, FLASH OR WEATHER STRIP. AROUND WINDOW AND DOOR FRAMES (PER MFG INSTALLATION SPECIFICATIONS), AT EXTERIOR JOINTS, OPENINGS BTWN WALL AND ROOF AND WALL PANELS, OPENINGS AT UTILITY PENETRATIONS THROUGH WALLS, FLOORS, AND ROOFS, ALL OTHER OPENINGS IN BLDG ENVELOPE.

CATHEDRAL CEILING (NO ATTIC) - VAPOR RETARDER SHALL HAVE A DRY GIP PERM RATE OF 1.0 OR LESS

ALL EXTERIOR DOORS OR ACCESS HATCHES TO ENCLOSED UNHEATED AREAS MUST BE WEATHER STRIPPED.

VENTILATION / AIR QUALITY REQUIREMENTS:

SOURCE SPECIFIC VENTILATION REQUIREMENTS

- BATHROOMS, LAUNDRY ROOMS AND POWDER ROOM FANS TO BE 50 CFM.
KITCHEN EXHAUST FANS TO BE 100 CFM.
EXHAUST FANS SHALL BE FLOW-RATED AT 25 W.G. STATIC PRESSURE

- EXHAUST DUCTS SHALL:
NO DUCTS SHALL BE PRESENT IN UNCONDITIONED SPACE
BE EQUIPPED WITH A BACK-DRAFT DAMPER
TERMINATE OUTSIDE THE BUILDING
COMPLY WITH DUCT LENGTH TABLE M504.2

WHOLE HOUSE VENTILATION REQUIREMENTS

- PER IRC M505.4.1.6, WHOLE HOUSE MECHANICAL VENTILATION SYSTEMS SHALL BE TESTED, BALANCED AND VERIFIED TO PROVIDE THE MINIMUM FLOW RATES REQUIRED BY M505.4.3 AND M505.4.4
A CONTINUOUS WHOLE HOUSE EXHAUST FAN SHALL BE PROVIDED AND SHALL BE SIZED TO PROVIDE THE MINIMUM VENTILATION RATE SPECIFIED IN TABLE M505.4.3(1) WITH VENTILATION QUALITY ADJUSTMENTS AS REQ'D PER M505.4.3.1 AND TABLE M505.4.3(2) FOR AN "UNBALANCED" AND "NOT DISTRIBUTED" SYSTEM
EXHAUST FANS MUST BE FLOW RATED AT 25 W.G. AND MAX. 1.0 SONE RATING.
CONTROLS FOR ALL VENTILATION SYSTEMS SHALL BE READILY ACCESSIBLE BY THE OCCUPANT AND MEET THE CONTROL AND OPERATION REQUIREMENTS OF M505.4.2.
A LABEL SHALL BE AFFIXED TO THE CONTROLS THAT READS "WHOLE HOUSE VENTILATION (SEE OPERATING INSTRUCTIONS)."
INTERIOR DOORS SHALL BE INSTALLED SO AS NOT TO IMPEDE THE MOVEMENT OF FRESH AIR TO ALL HABITABLE ROOMS (1/2" UNDERCUT ABOVE SURFACE OF FINISH FLOOR COVERING UNO.).
AN AIR TRANSFER GRILLE SHALL BE PROVIDED ABOVE OR WITHIN UTILITY ROOM DOOR TO PROVIDE SUFFICIENT MAKE-UP AIR FOR EXHAUST AS REQUIRED
EACH HABITABLE SPACE SHALL BE PROVIDE WITH OUTDOOR AIR INLETS OR OPERABLE WINDOWS. OUTDOOR AIR INLETS SHALL PROVIDE AT LEAST 4 SQUARE INCHES OF NET FREE AREA OPENING FOR EA 10 CFM OF OUTDOOR AIR REQ BY M505.4.3(1). INLETS SHALL BE SCREENED AND SHALL NOT DRAW AIR FROM PROHIBITED LOCATIONS LISTED UNDER I.R.C. M505.4.3

LOTUS 'A'

(62-40-01)

MAINVUE WA, LLC logo and contact information: 121 3rd Ave, Kirkland, WA 98033, Phone: (425) 646-4022, Fax: (425) 646-4024

LOTUS 'A' (62-40-01)
EXTENDED PORCH FOR TRT

COVER SHEET
DESIGN: SU DRAWN: SS
PLAN NO: 62-40-01
SHEET A0.0
22x34 - 1/4" = 1'-0"
11x17 - 1/8" = 1'-0"

© 2023 MainVue Homes, LLC. All rights reserved.









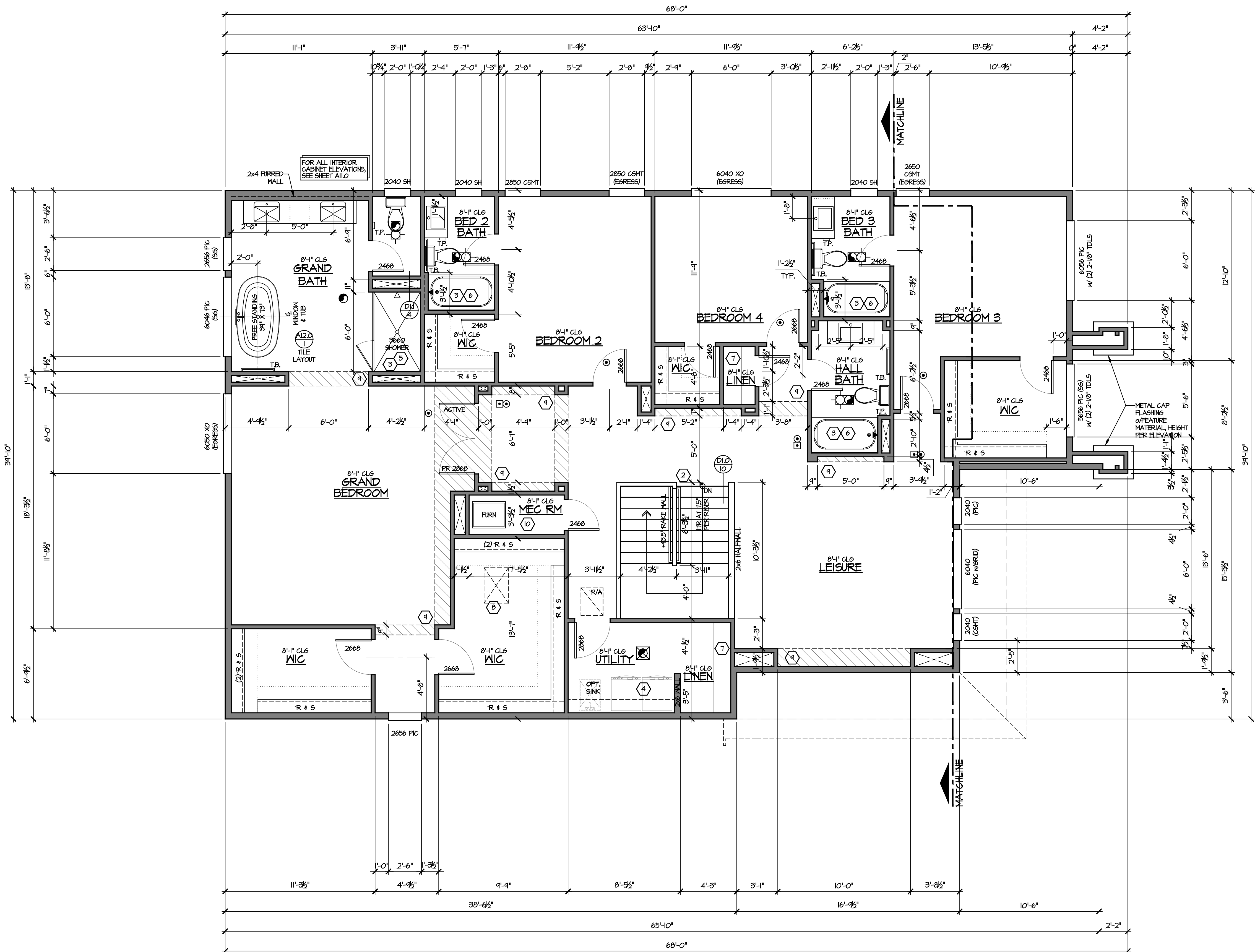

**APPROVED**  
 Plans Reviewed by **SAFEbuilt**  
 For Building Code Compliance  
 Reviewed By:  
 Bobby Thomas CBO, Plans Examiner,  
 Combination Inspector  
 Date:  
**7/20/2023 REV 1**

**KEYNOTES (NOT ALL USED)**

- 1 —
- 2 2x12 HANDRAIL BLK'g AT 36" ABOVE TREAD TO T.O. BLOCK
- 3 PROVIDE VERT FLAT BLK'g NAILER AT EA SIDE OF TUB/SHR
- 4 M & D (ALWAYS INSTALL DRYER TO THE RIGHT OF WASHER ON SITE)
- 5 SHOWER FAN W/ 2x12 BLK'g AT SHOWER BASE, ALL SIDES
- 6 AT TUB/SHR INSERT = FIRE BLK'g AT +12", (3) SIDES, SHR HEAD AT +75"  
 AT SHR INSERT = FIRE BLK'g AT +77", (3) SIDES, SHR HEAD AT +80"
- 7 (4) 16" SHELVES
- 8 22"x32" ATTIC ACCESS
- 9 SOFFIT TO T-4"
- 10 FURNACE PER SPEC. - REFER TO MEC PRESCRIPTIVE ENERGY CODE WORKSHEET FOR TYPE & SIZE REQMTS
- 11 —
- 12 —
- 13 —
- 14 —

**FLOOR PLAN NOTES**

1. ALL PLATE AND HEADER HEIGHTS PER ELEVATIONS, UNO.
2. ALL STAIRS TO HAVE UNIFORM RISERS
3. GLASS ENCLOSURE DOORS TO BE LABELED CATEGORY II
4. PROVIDE MR. BACKER BOARD AT TUBS/SHWRS TO T2" A.F.F.
5. VERIFY ALL WINDOW SIZES AND PATTERNS WITH BUILDER
6. SEE COVER SHEET, A.O.D. FOR HEATING AND ENERGY SPECIFICATIONS AND VENTILATION REQUIREMENTS
7. ENTRY DOOR FROM GARAGE TO BE 20 MIN RATED SOLID CORE WOOD NOT LESS THAN 1-3/8" THICK, EQUIPPED WITH A SELF-CLOSING DEVICE PER IRC R302.5.1
8. PROVIDE STAIRWAY ILLUMINATION PER R303.7
9. UTILITY ROOM ADDITIONAL AIR (15"x14.5" LOVERED VENT)

**SYMBOLS LEGEND**

	50 CFM FAN VENT TO OUTSIDE
	FANLIGHT COMBO W/ 50 CFM FAN VENT TO OUTSIDE
	CONTINUOUS WHOLE HOUSE FAN - 120 CFM MIN. VENT TO OUTSIDE
	SMOKE DETECTOR, INTERCONNECTED AND HARD WIRED W/ BATTERY BACKUP
	CARBON MONOXIDE COMBO DETECTOR, INTERCONNECTED AND HARD WIRED W/ BATTERY BACKUP
	OPEN RAILING TO 36" AFF. ATOP 3" CURB WALL, UNO.
	1/2 HEIGHT WALL TO BE 42" AFF., UNO.
	RECESSED CAN LOCATION (SEE ELECTRICAL)
	VENEER SIDING, SEE ELEVATIONS
	T.O. DOWNEPOUT - SEE PLAN FOR LOCATIONS
	B.O. DOWNEPOUT - SEE PLAN FOR LOCATIONS

<b>UPPER FLOOR PLAN</b>	<b>LOTUS 'A' (62-40-01)</b>	<b>STREXENBACHOPRON NOME RIERE</b>	<b>MAINVUE WA, LLC</b>	<table border="1" style="width: 100%; border-collapse: collapse;"> <tr> <th style="width: 10%;">NO.</th> <th style="width: 10%;">DATE</th> <th style="width: 80%;">DESCRIPTION</th> </tr> <tr> <td style="text-align: center;">1</td> <td style="text-align: center;">07-11-23</td> <td style="text-align: center;">EXTENDED PORCH VERSION FOR TRT-51 (62)</td> </tr> <tr> <td style="text-align: center;">2</td> <td style="text-align: center;">07-11-23</td> <td style="text-align: center;">EXTENDED PORCH VERSION FOR TRT-51 (62)</td> </tr> <tr> <td style="text-align: center;">3</td> <td style="text-align: center;">07-11-23</td> <td style="text-align: center;">EXTENDED PORCH VERSION FOR TRT-51 (62)</td> </tr> </table>	NO.	DATE	DESCRIPTION	1	07-11-23	EXTENDED PORCH VERSION FOR TRT-51 (62)	2	07-11-23	EXTENDED PORCH VERSION FOR TRT-51 (62)	3	07-11-23	EXTENDED PORCH VERSION FOR TRT-51 (62)
NO.	DATE	DESCRIPTION														
1	07-11-23	EXTENDED PORCH VERSION FOR TRT-51 (62)														
2	07-11-23	EXTENDED PORCH VERSION FOR TRT-51 (62)														
3	07-11-23	EXTENDED PORCH VERSION FOR TRT-51 (62)														
<p>DESIGN: SU      DRAWN: SS</p> <p>PLAN No: 62-40-01.02.1 A</p> <p><b>SHEET A4.1</b></p> <p>22x34 - 1/4" = 1'-0" 11x17 - 1/8" = 1'-0"</p>																







APPROVED  
 Plans Reviewed by SAFEbuilt LLC  
 For Building Code Compliance  
 Reviewed By:  
 Bobby Thomas CBO, Plans Examiner,  
 Combination Inspector  
 Date:  
 7/20/2023 REV 1

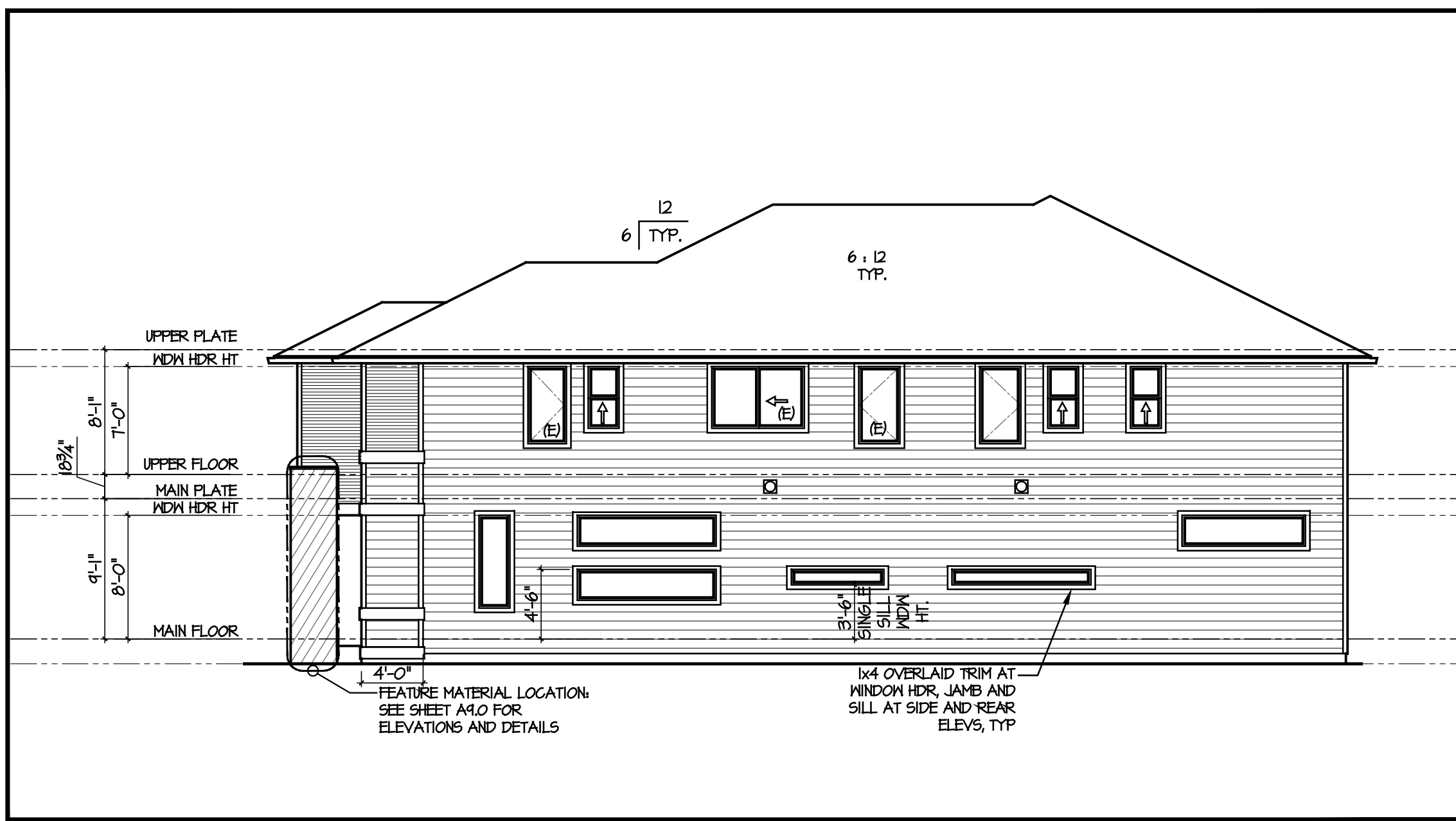

SIDE ELEVATION

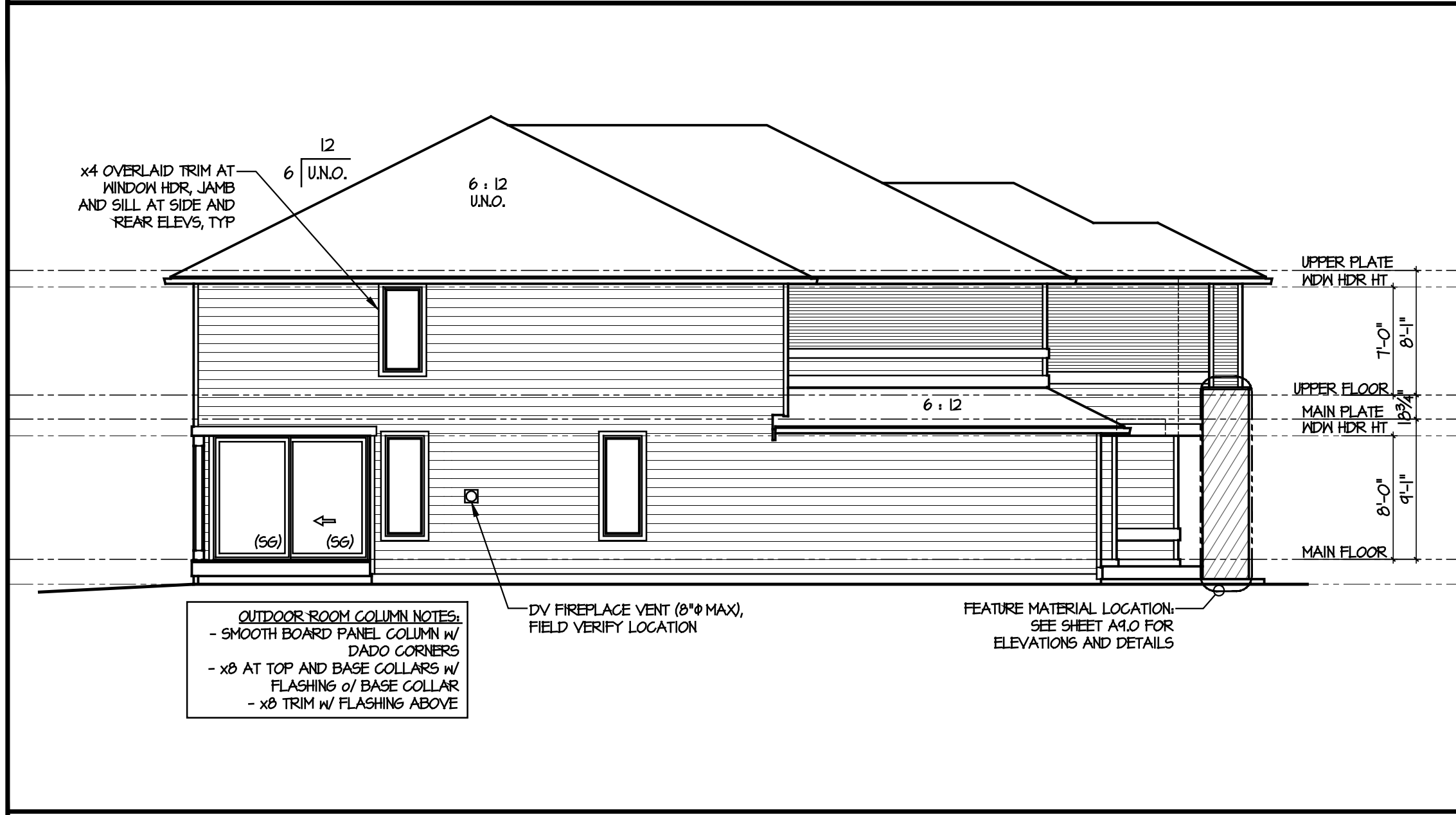

SIDE ELEVATION

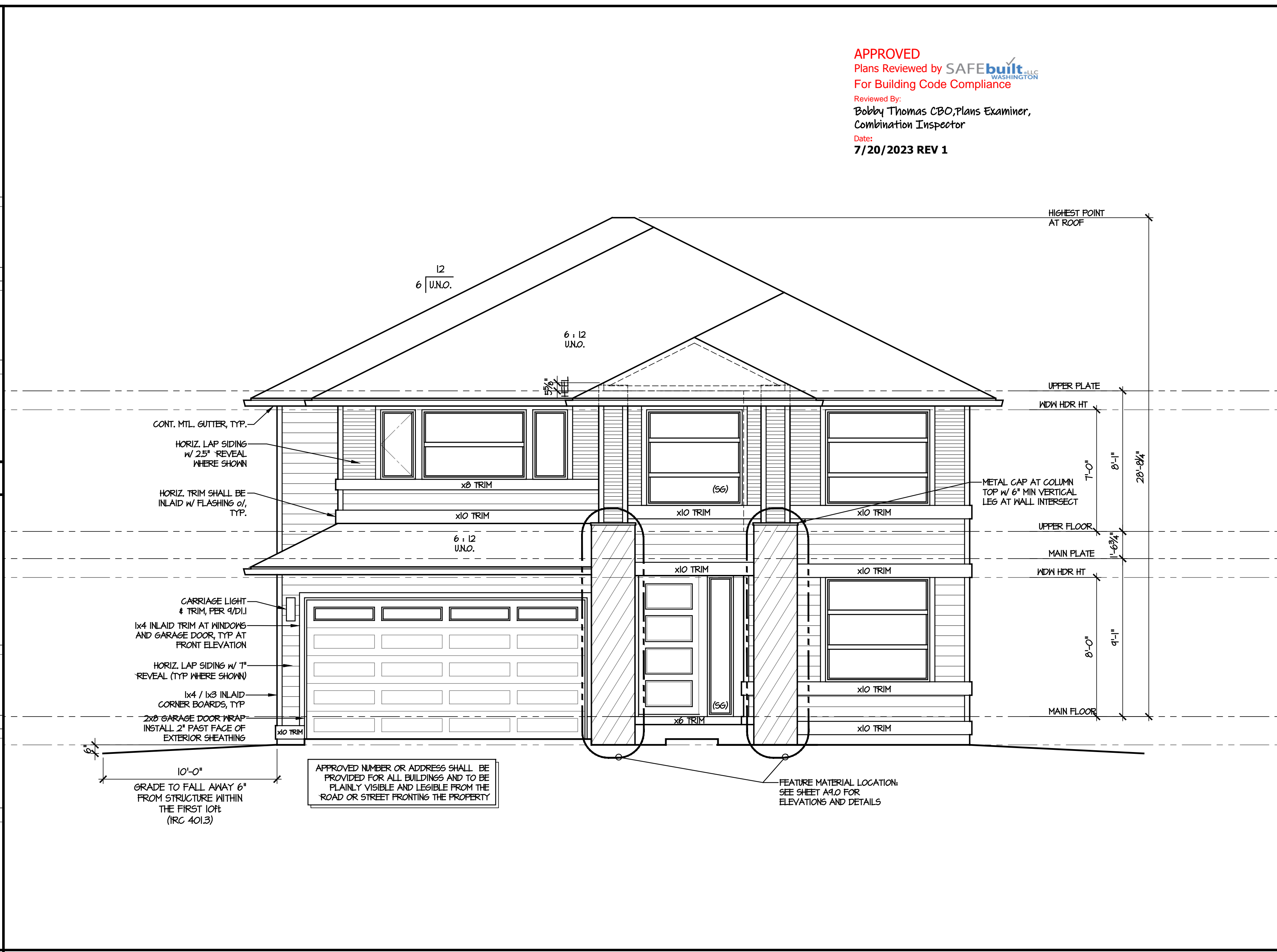

FRONT ELEVATION

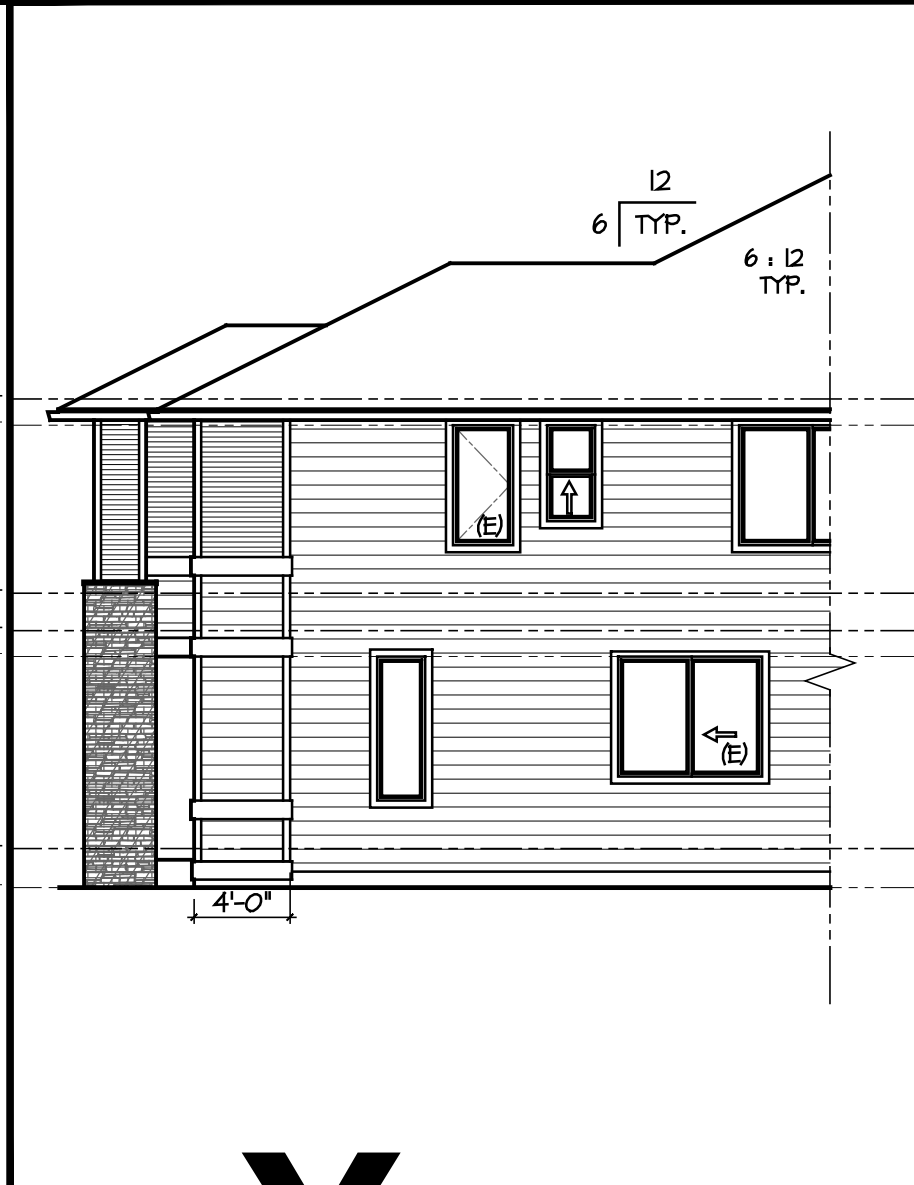

GUEST ROOM ILO MPR

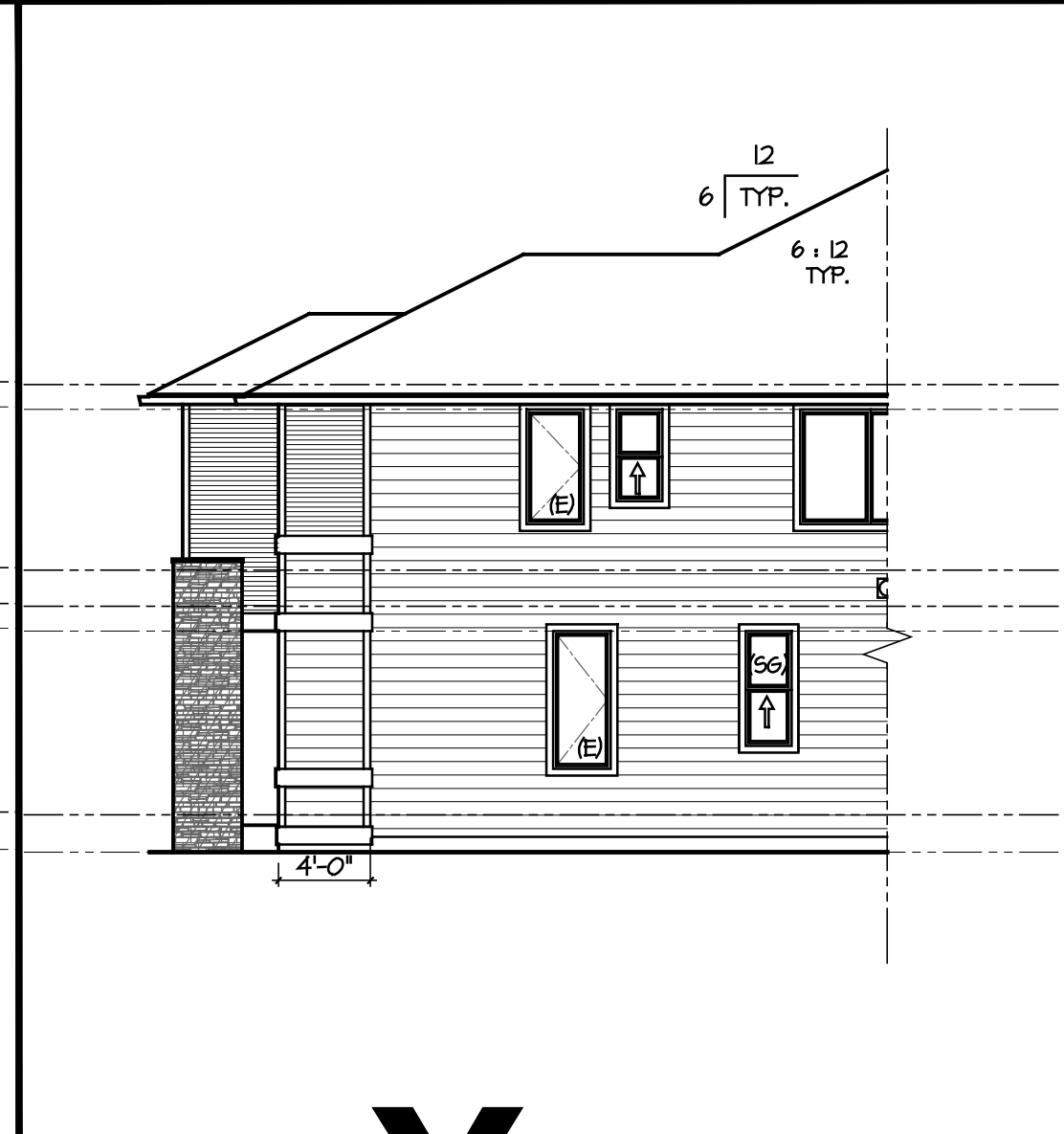

GUEST SUITE NO MPR & H.O.



NOT USED

DESCRIPTION		EXTENDED PORCH VERSION FOR TRT-51 (62)	
DATE	07-11-23		
NO.	1		
DESIGNER		SU	
DRAWN		SS	
PLAN NO.		62-40-01.02.1 A	
SHEET		A6.0	
22x34 - 1/4" = 1'-0"		11x17 - 3/8" = 1'-0"	
© 2023 MainVue Homes, LLC. All rights reserved.			

LOTUS 'A' (62-40-01)  
 EXTENDED PORCH FOR TRT

EXTERIOR ELEVATIONS

DESIGN: SU  
 DRAWN: SS  
 PLAN NO:  
 62-40-01.02.1 A  
 SHEET  
 A6.0  
 22x34 - 1/4" = 1'-0"  
 11x17 - 3/8" = 1'-0"

121 3rd Ave  
 Kirkland, WA 98033  
 Phone: (425) 646-4022  
 Fax: (425) 646-4024

MAINVUE  
 WA, LLC



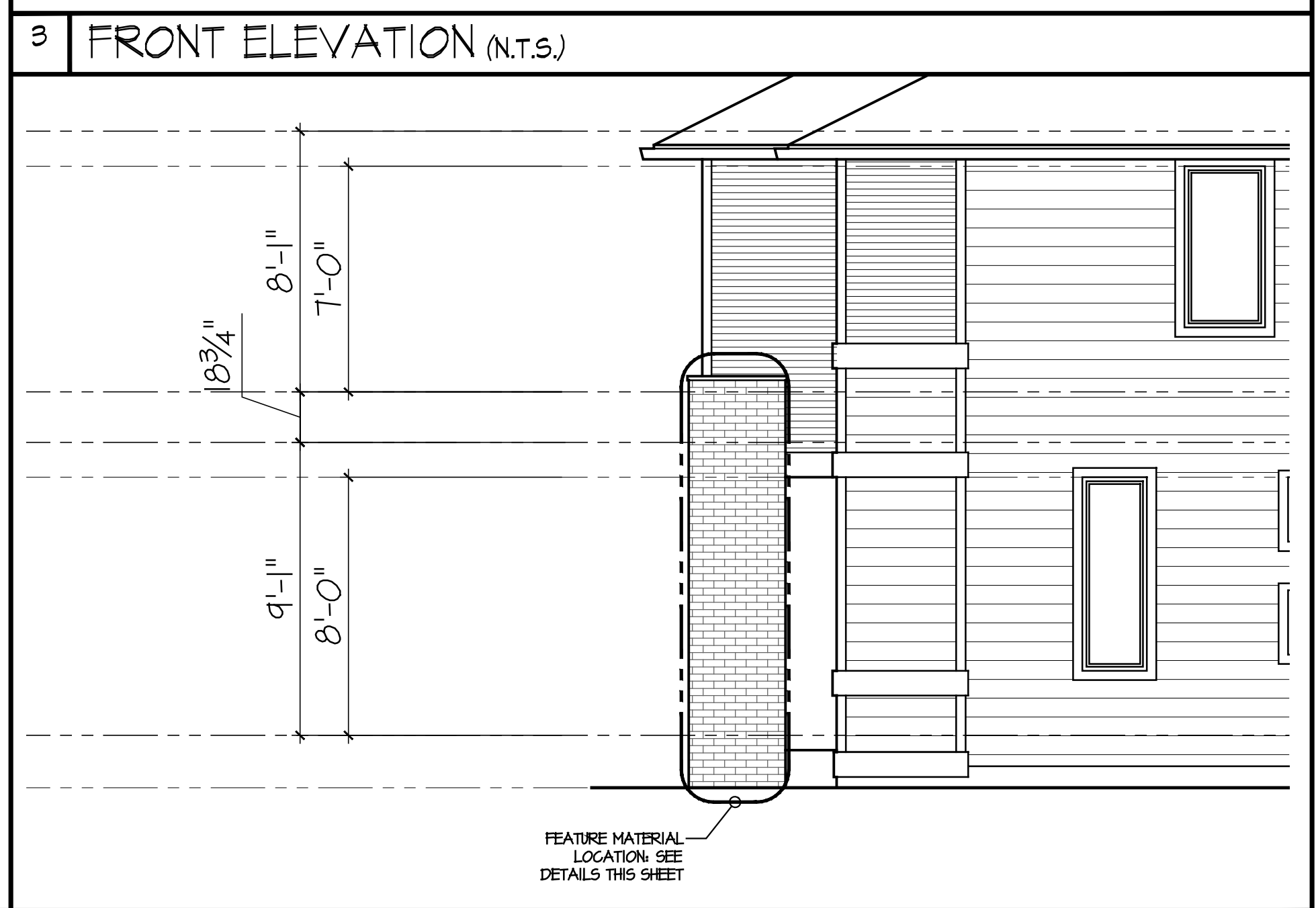
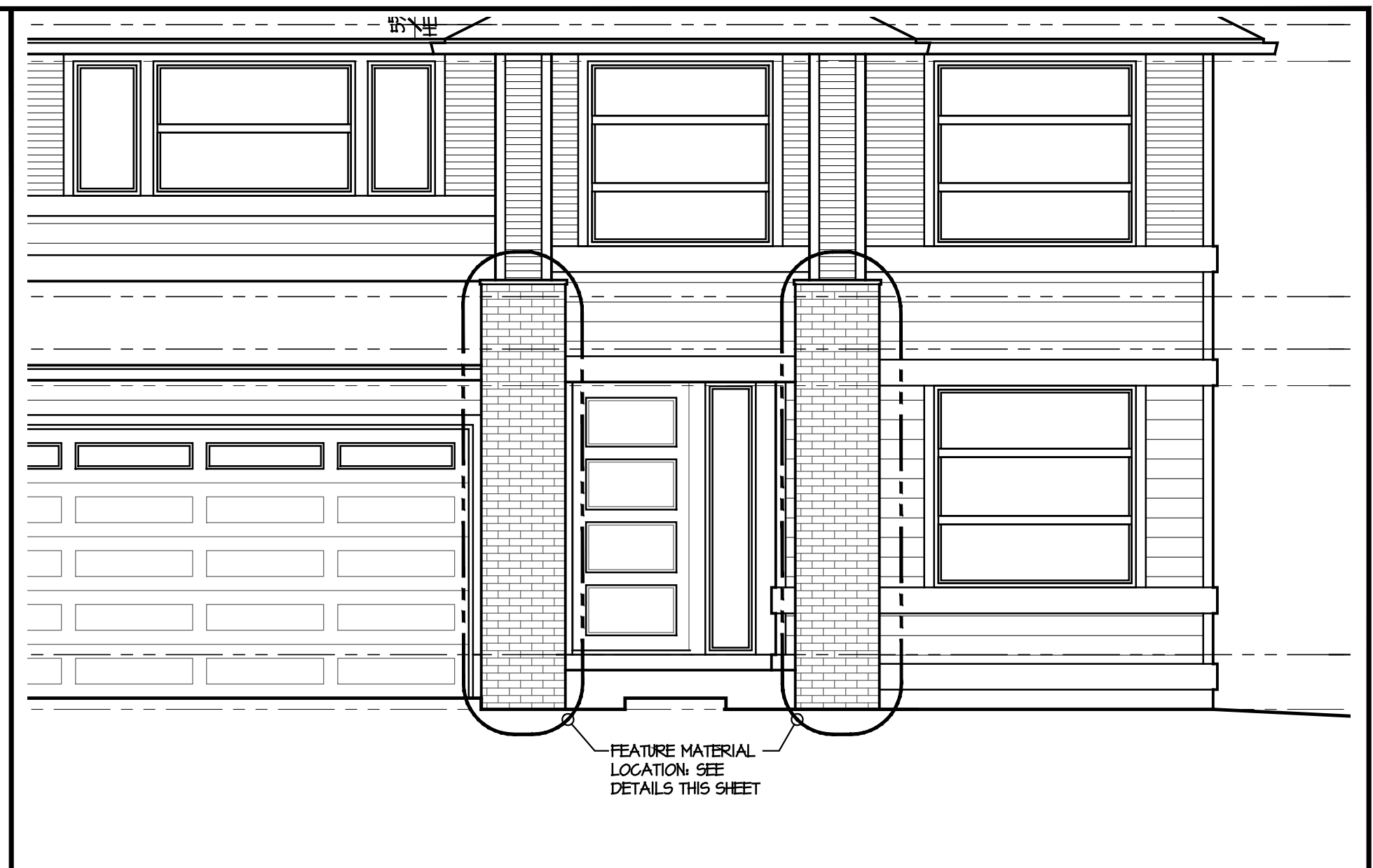
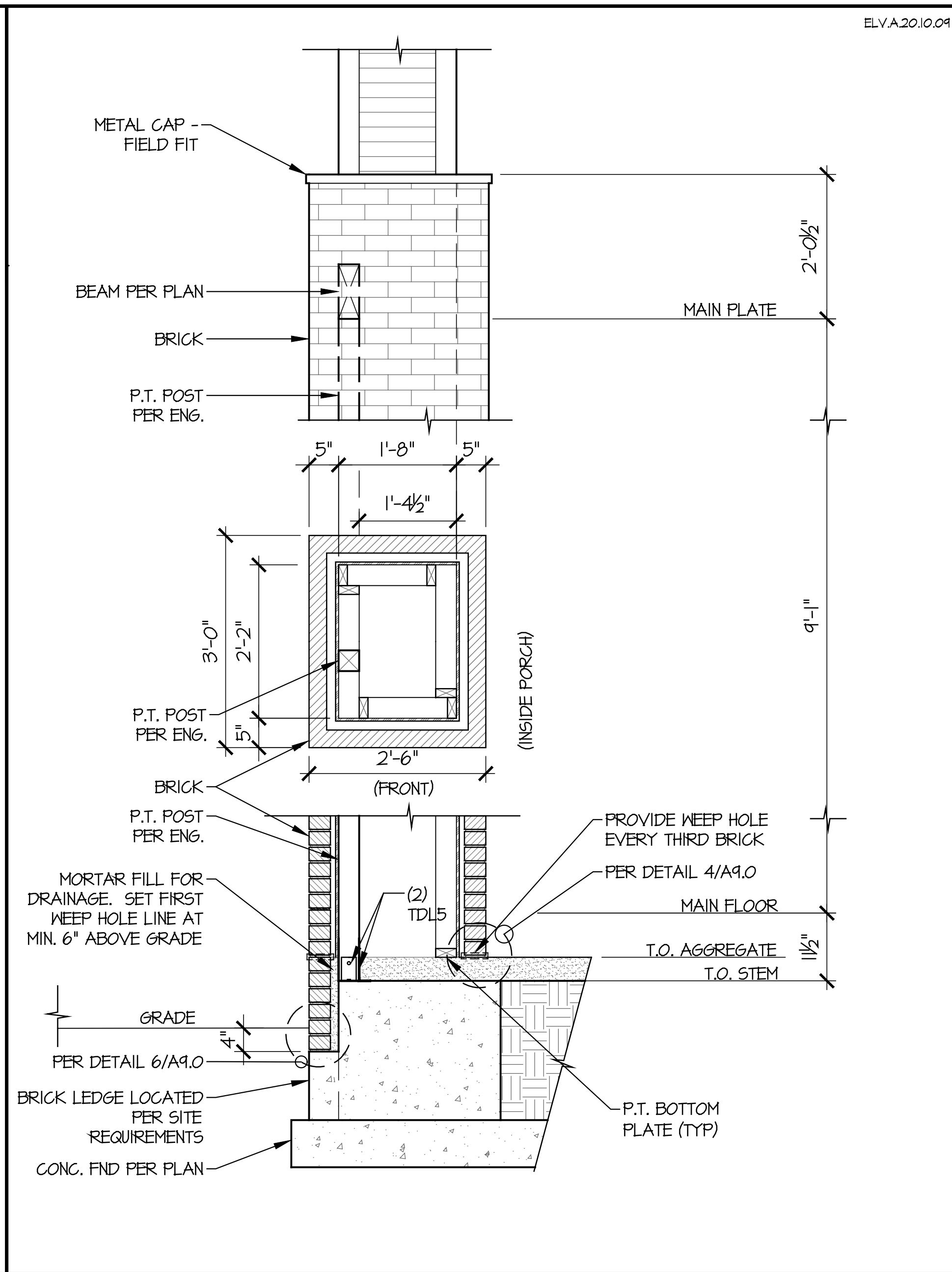

7 NOT USED

5 'A' FEATURE COLUMN SECTION - BRICK

3/4" 2 SIDE ELEVATION (N.T.S.)

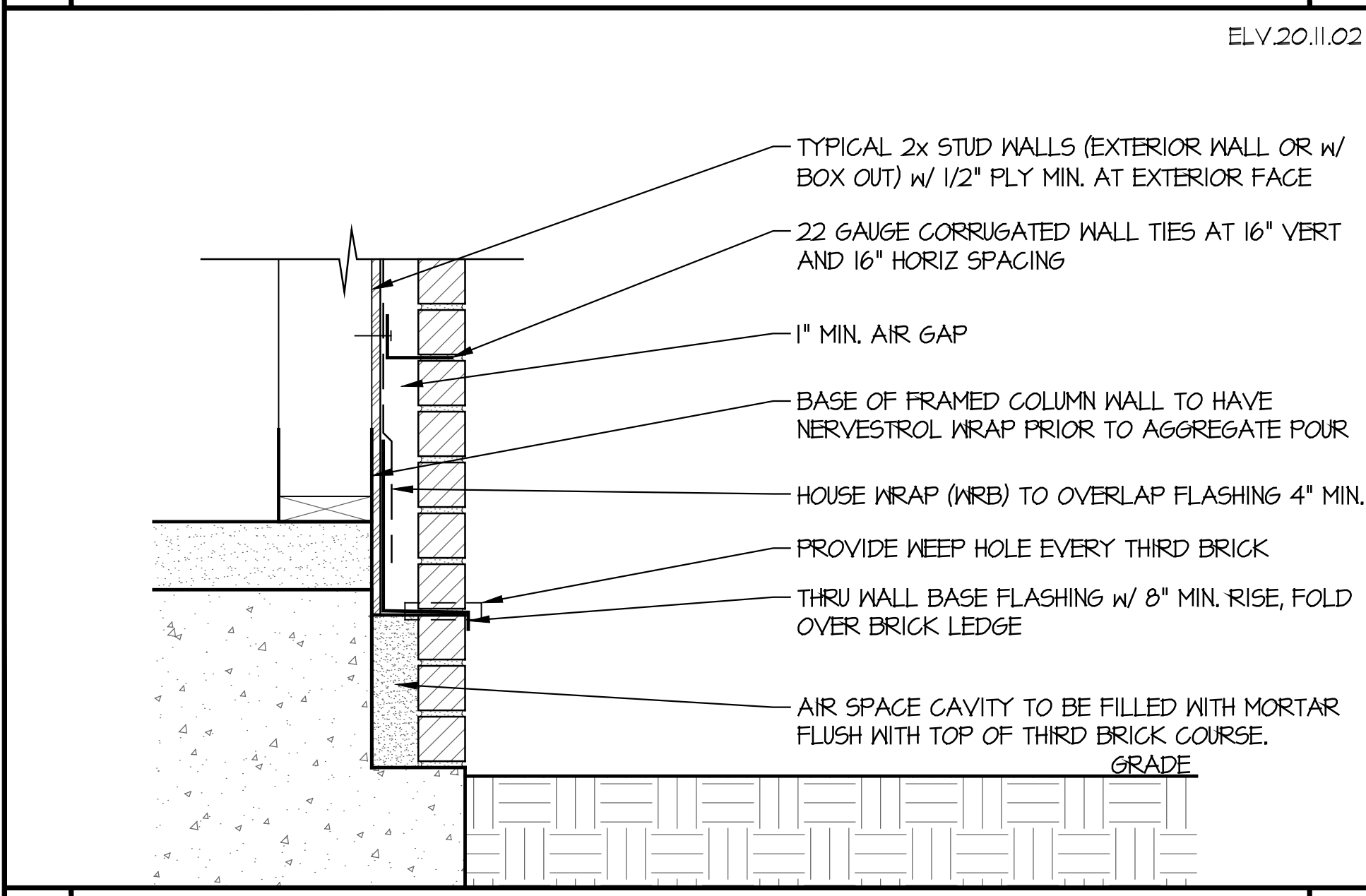

6 DROPPED BRICK LEDGE AT FOUNDATION

1/2" 4 NOT USED

1 SIDE ELEVATION (N.T.S.)

DESCRIPTION		EXTENDED FRONT PORCH VERSION FOR TRT-5I	
DATE	07/11/23		
NO.	1	2	3
121 3rd Ave Kirkland, WA 98033 Phone: (425) 646-4022 Fax: (425) 646-4024			
MAINVUE		WA, LLC	
LOTUS 'A' (62-40-01)			
EXTENDED PORCH FOR TRT			
FEATURE MATERIAL:		BRICK (2)	
DESIGN:	SU	DRAWN:	SS
PLAN No:		62-40-01	
SHEET		A9.0	
22x34 - 1/4" = 1'-0"		11x17 - 1/8" = 1'-0"	



5 NOT USED

4 NOT USED

3 NOT USED

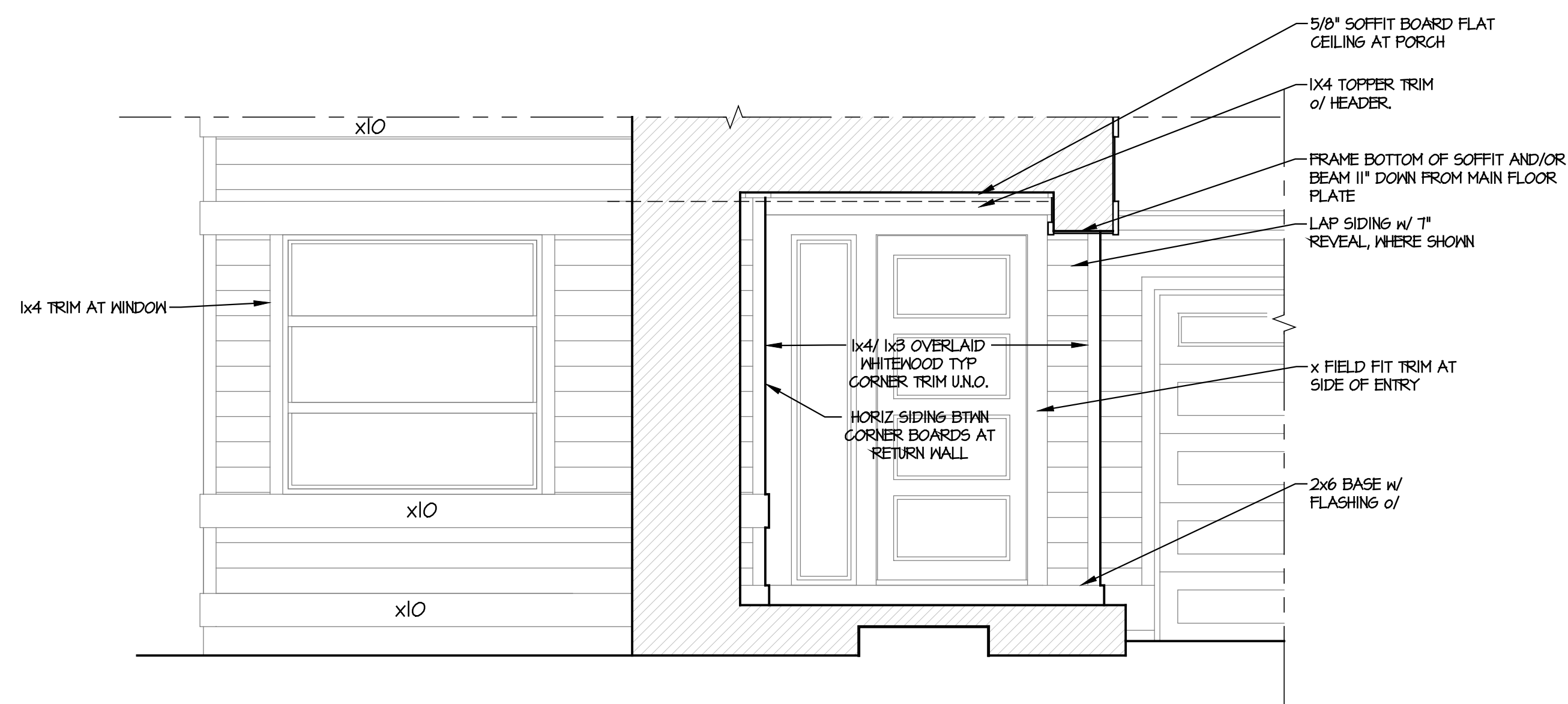

2 HIDDEN PORCH ELEVATION

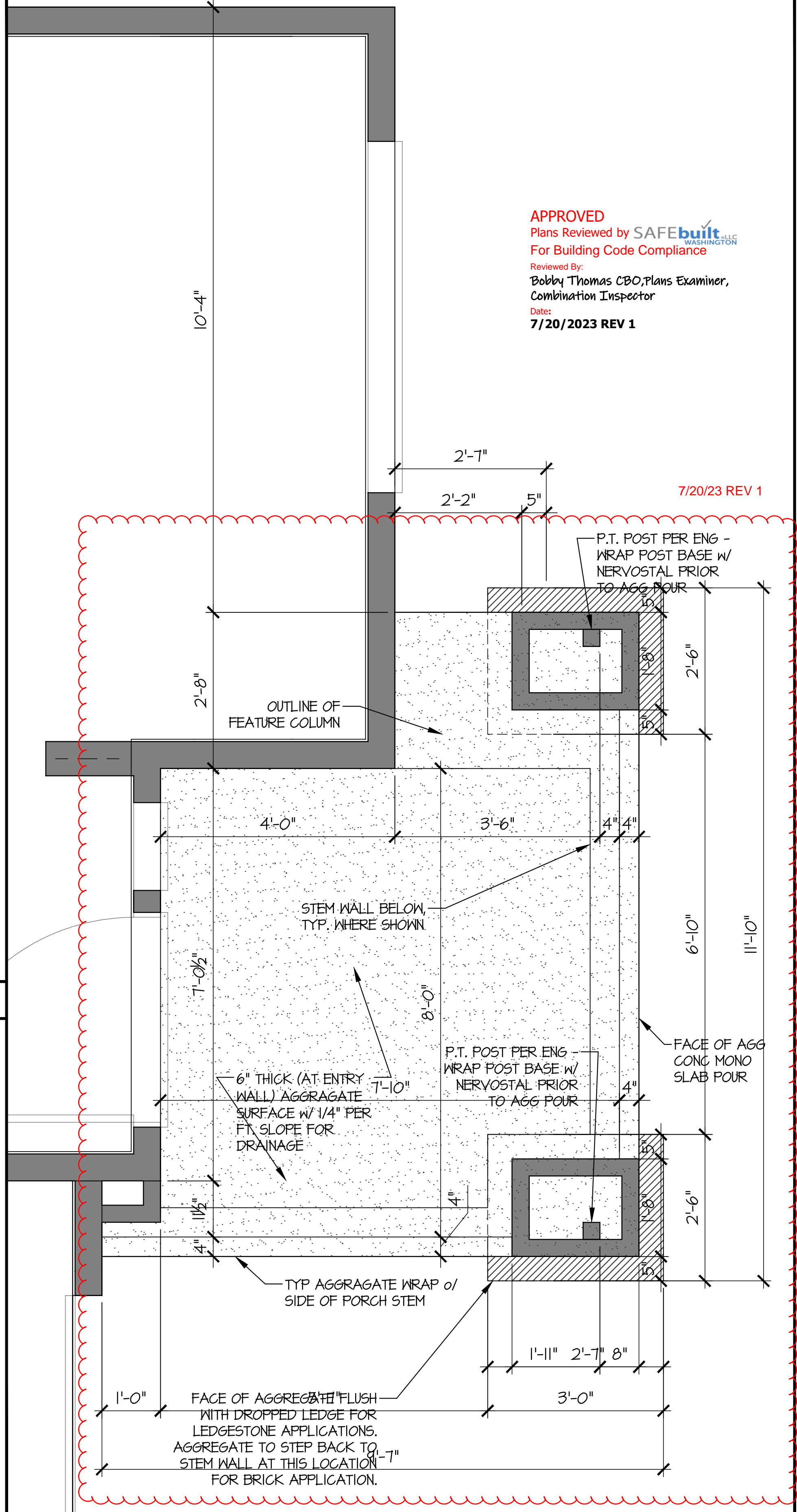

1 PORCH AGGREGATE OVERLAY

APPROVED  
Plans Reviewed by **SAFEbuilt**  
For Building Code Compliance  
Reviewed By:  
Bobby Thomas CBO, Plans Examiner,  
Combination Inspector  
Date:  
7/20/2023 REV 1

No.	DATE	DESCRIPTION
1	07/19/23	EXTENDED FRONT PORCH VERSION FOR TRT-5I
2		
3		
4		

121 3rd Ave  
Kirkland, WA 98033  
Phone: (425) 646-1022  
Fax: (425) 646-4024

**MAINVUE**  
WA, LLC

LOTUS 'A' (62-40-01)  
EXTENDED PORCH FOR TRT

ELEVATION SPECIFIC DETAILS

DESIGN: SU DRAWN: SS  
PLAN No: 62-40-01

SHEET A9.1  
22x34 - 1/4" = 1'-0"  
11x17 - 1/8" = 1'-0"

© 2023 MainVue Homes, LLC. All rights reserved.



ALL DIMENSIONS ARE TO FACE OF FINISH MATERIAL, UNO

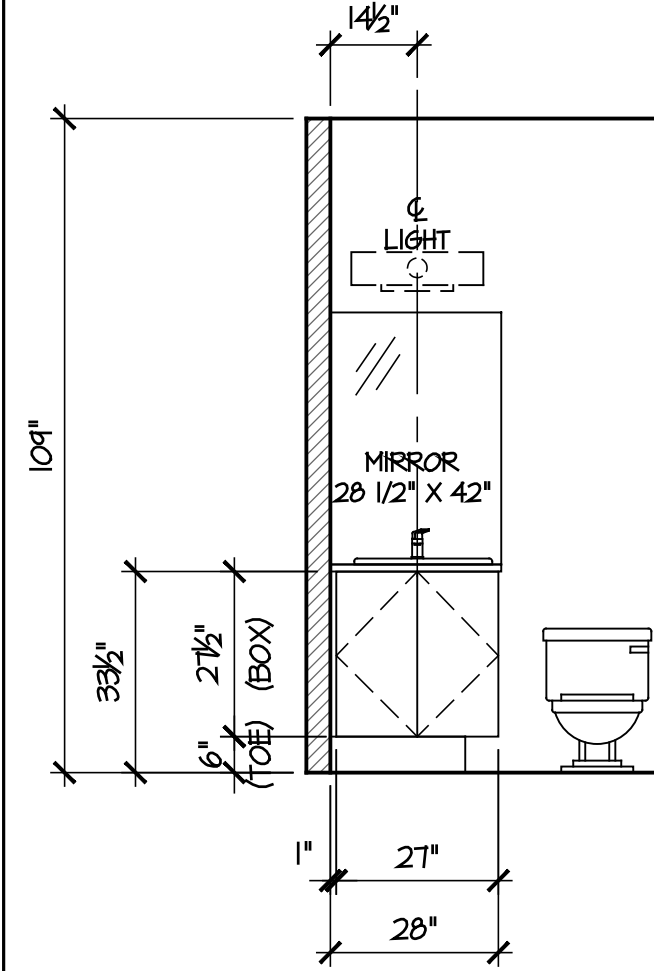
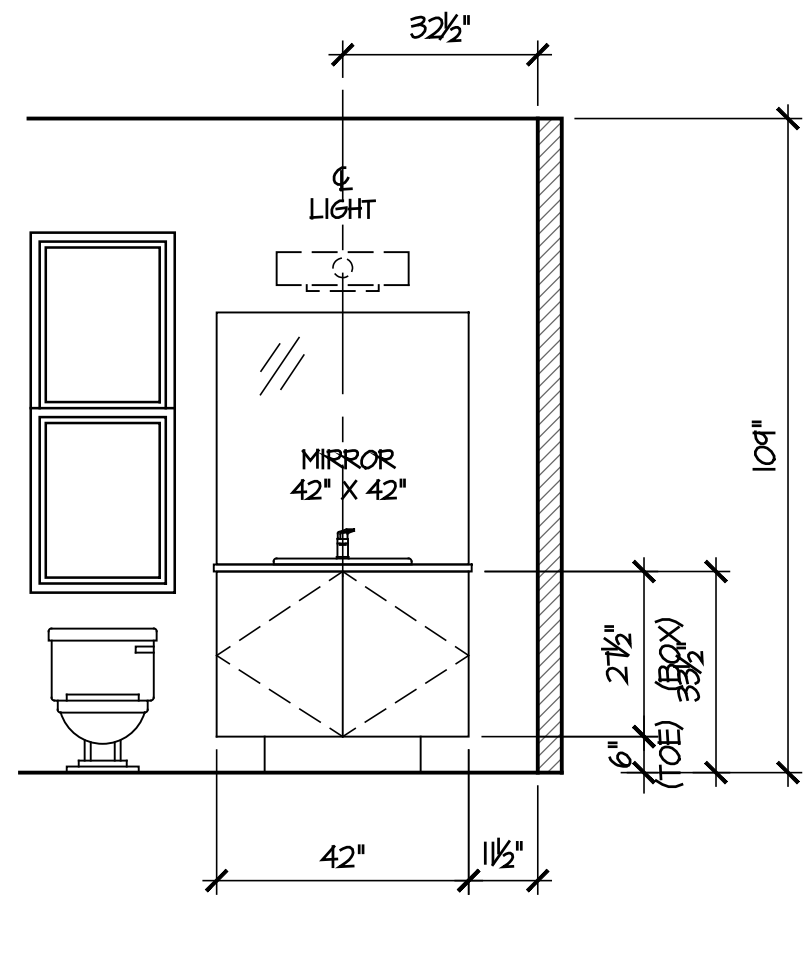
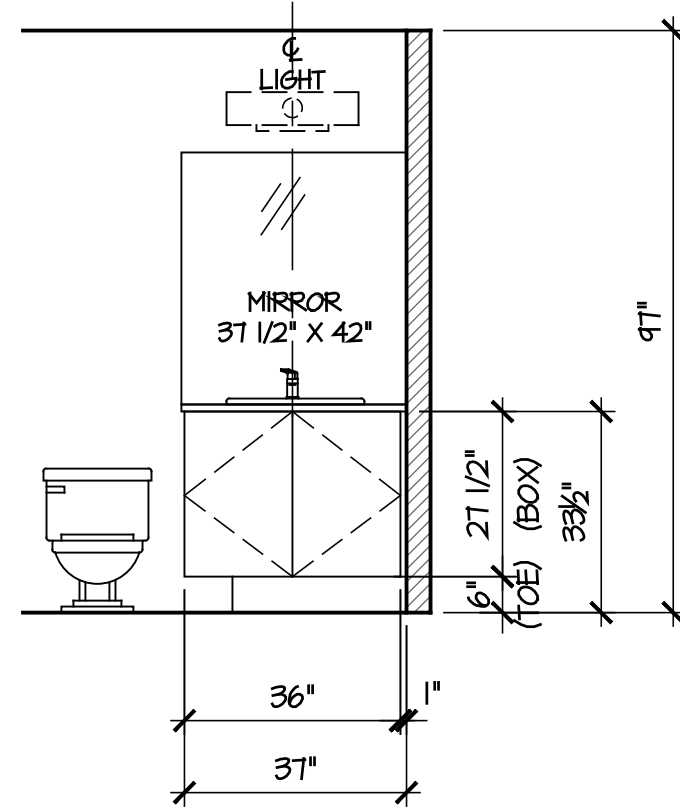
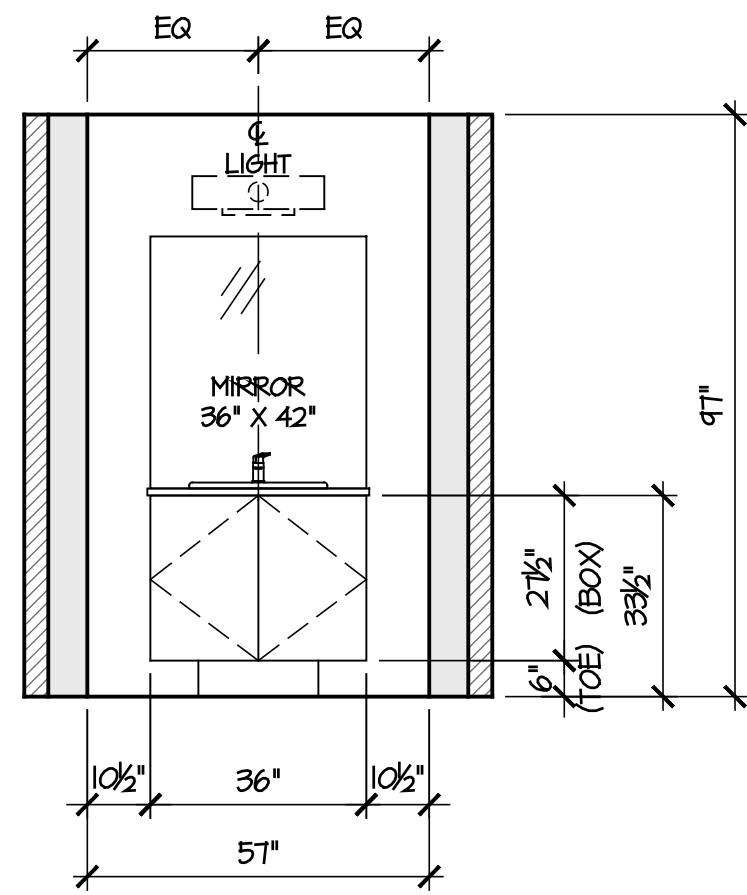

**APPROVED**  
 Plans Reviewed by **SAFEbuilt**  
 For Building Code Compliance  
 Reviewed By:  
 Bobby Thomas CBO, Plans Examiner,  
 Combination Inspector  
 Date:  
**7/20/2023 REV 1**

HALL BATH (N.T.S.) 10

BED 2 / BED 3 BATH (N.T.S.) 11

OPT. MAIN FLOOR GUEST BATH 12

OPTIONAL 3/4 BATH 13

NOT USED 14

NOT USED 15

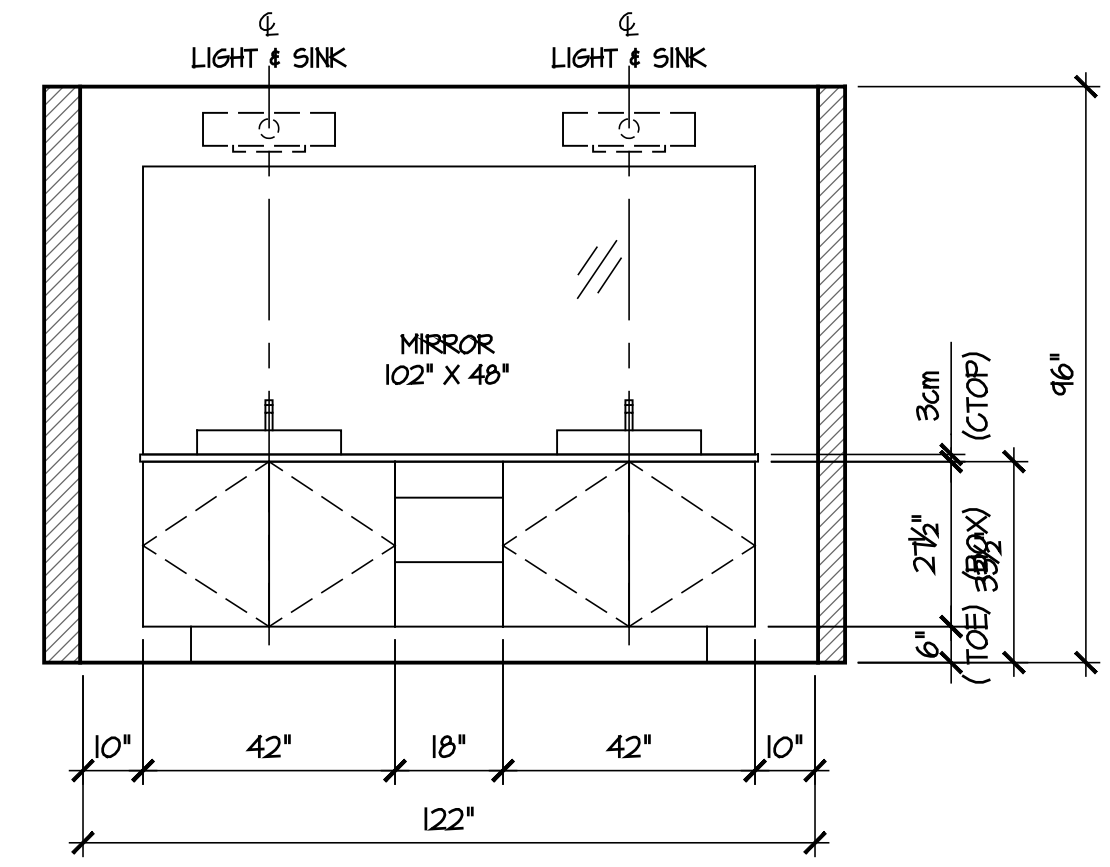
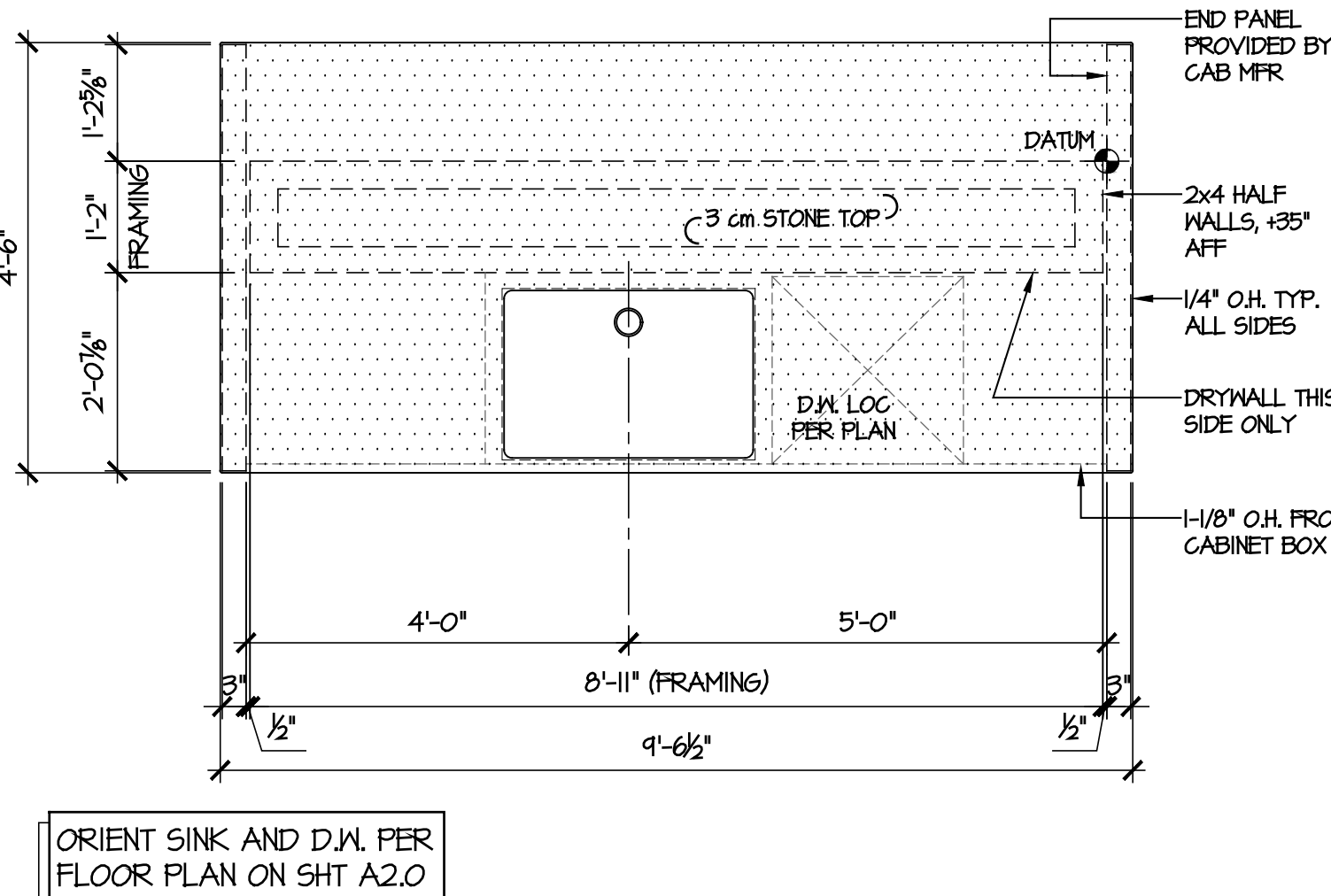
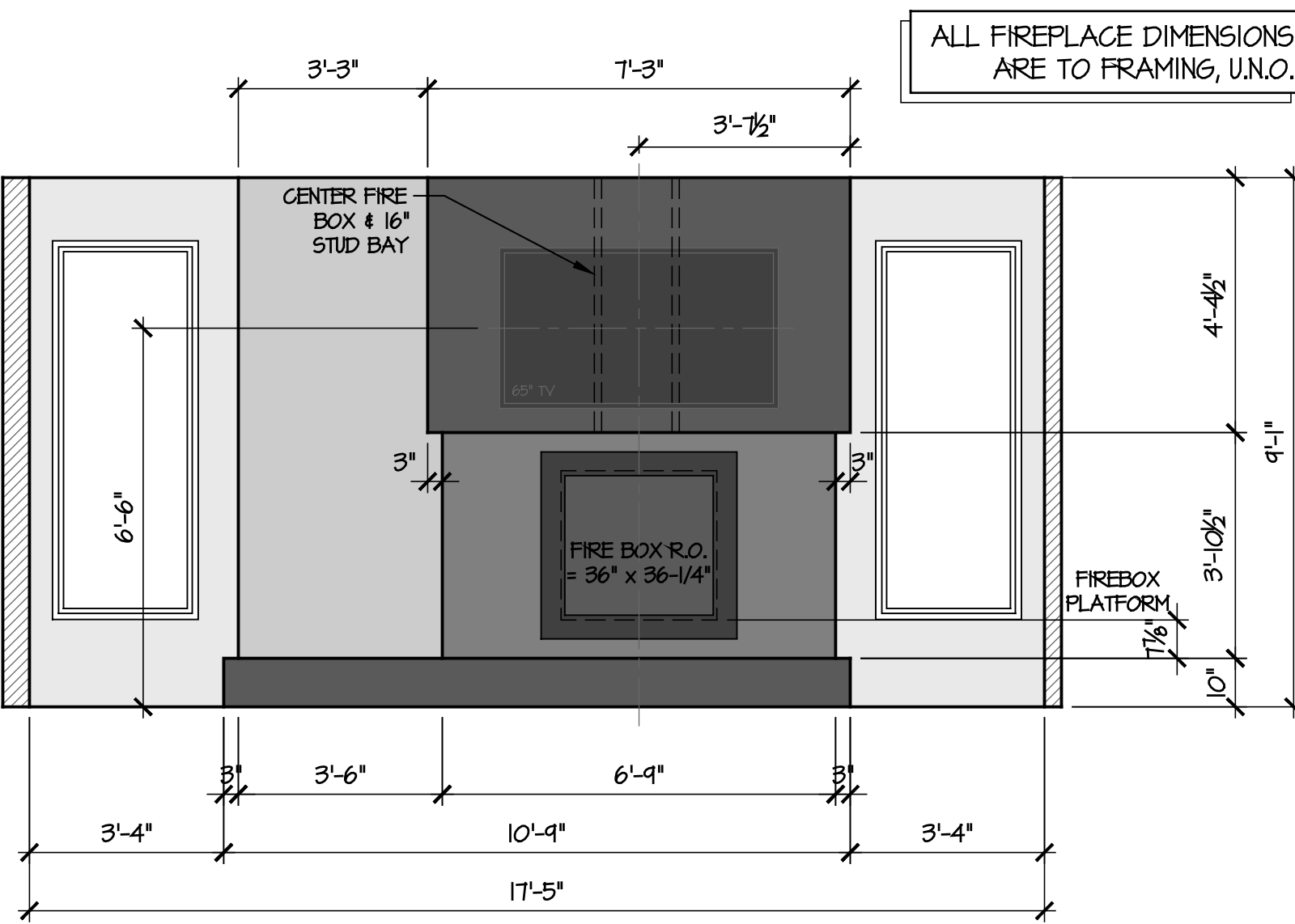
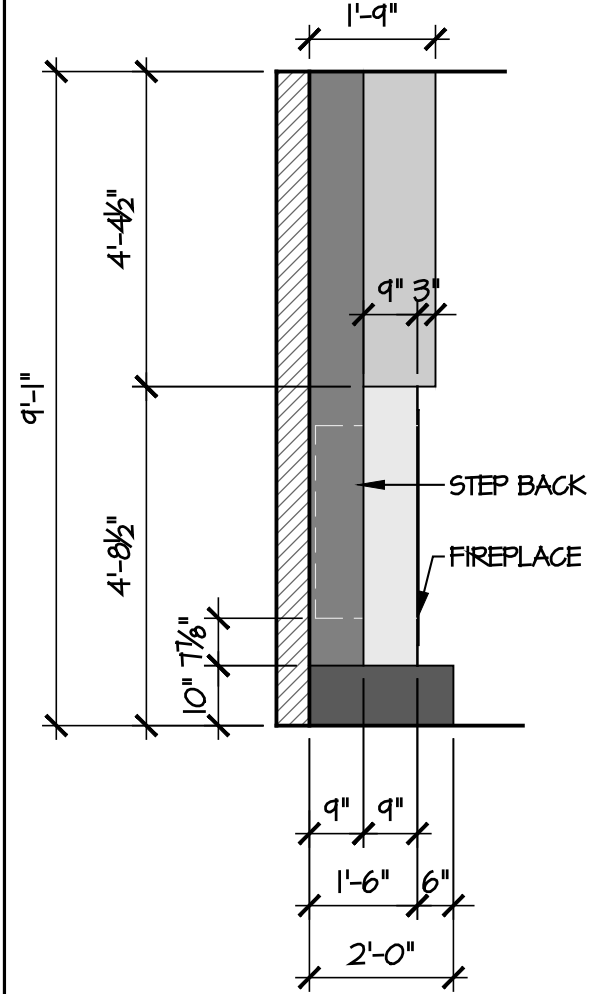
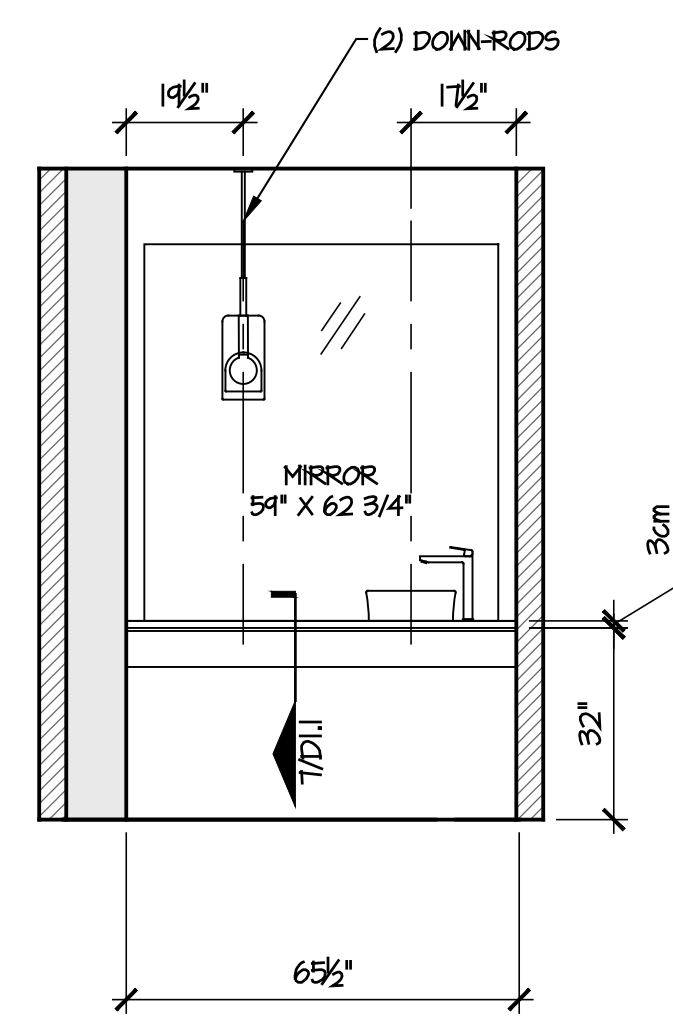

POWDER BATH (N.T.S.) 6

GREAT ROOM FIREPLACE DETAIL (N.T.S.) 7

KITCHEN ISLAND DETAIL (N.T.S.) 8

GRAND BATHROOM (N.T.S.) 9

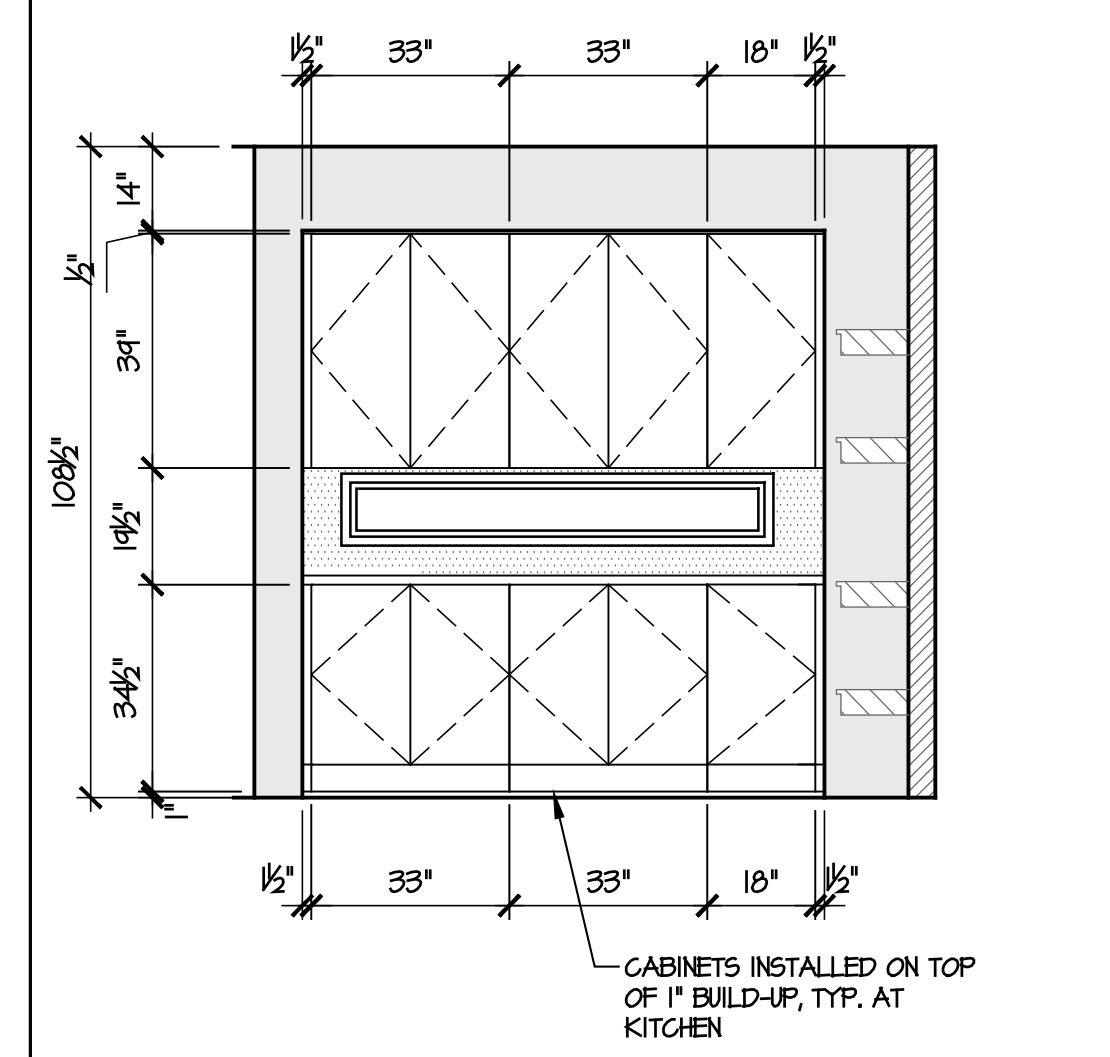
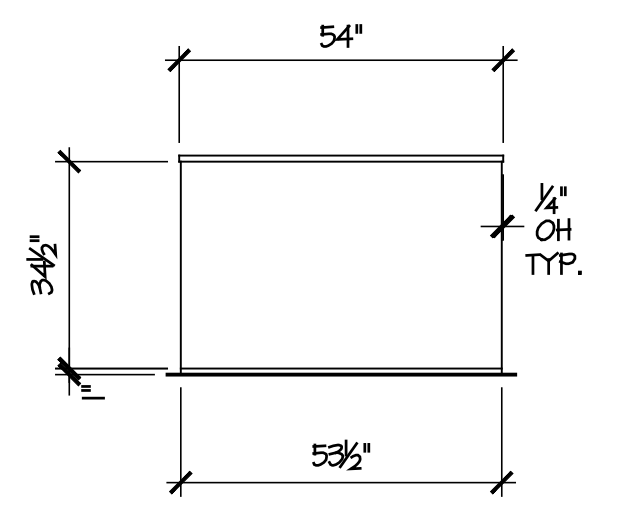
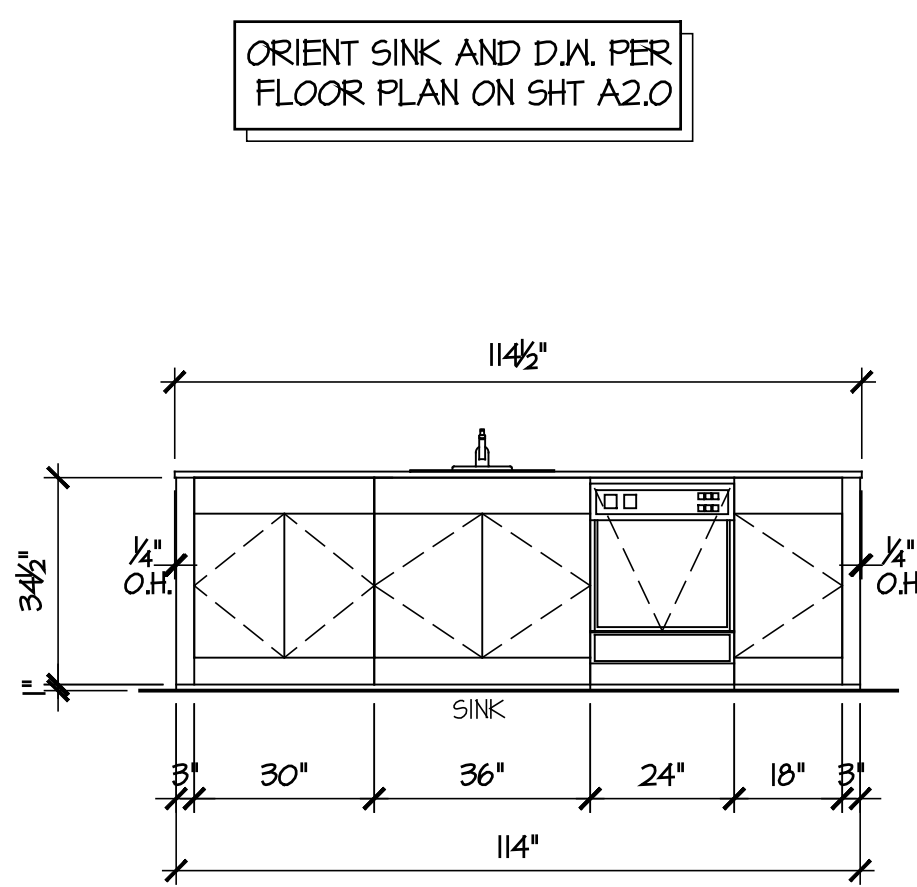
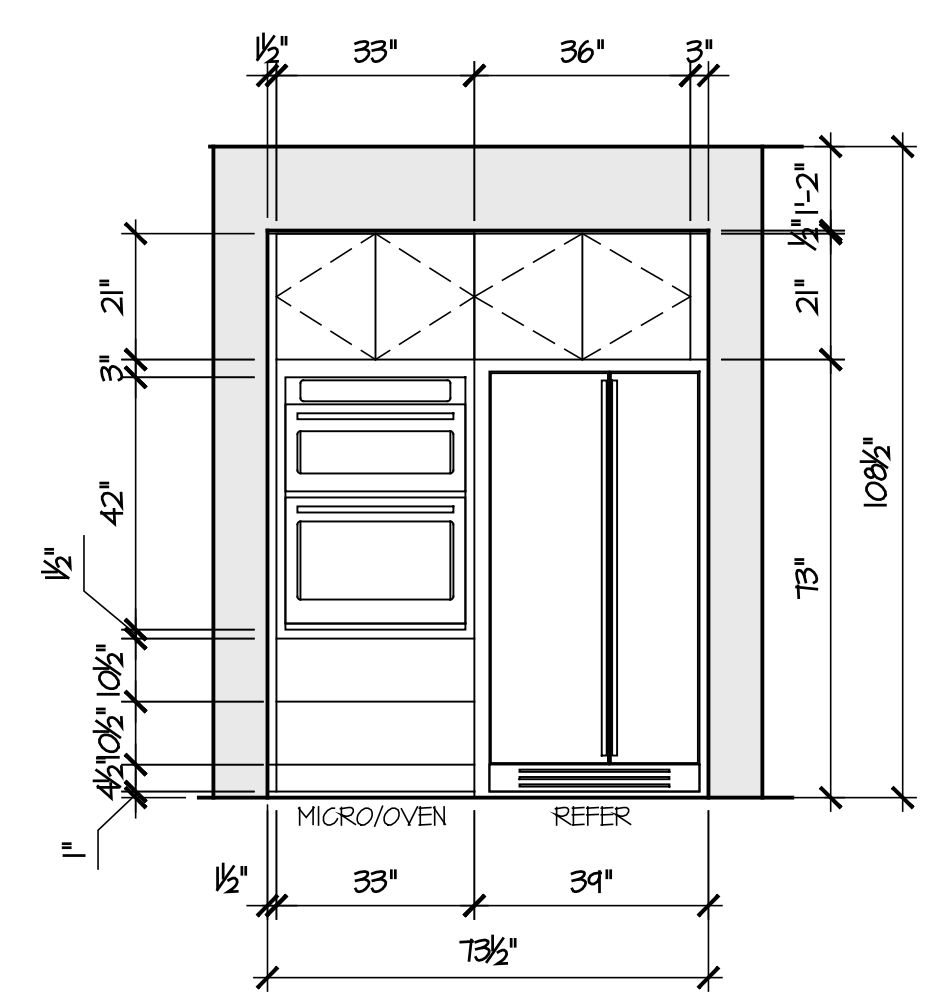
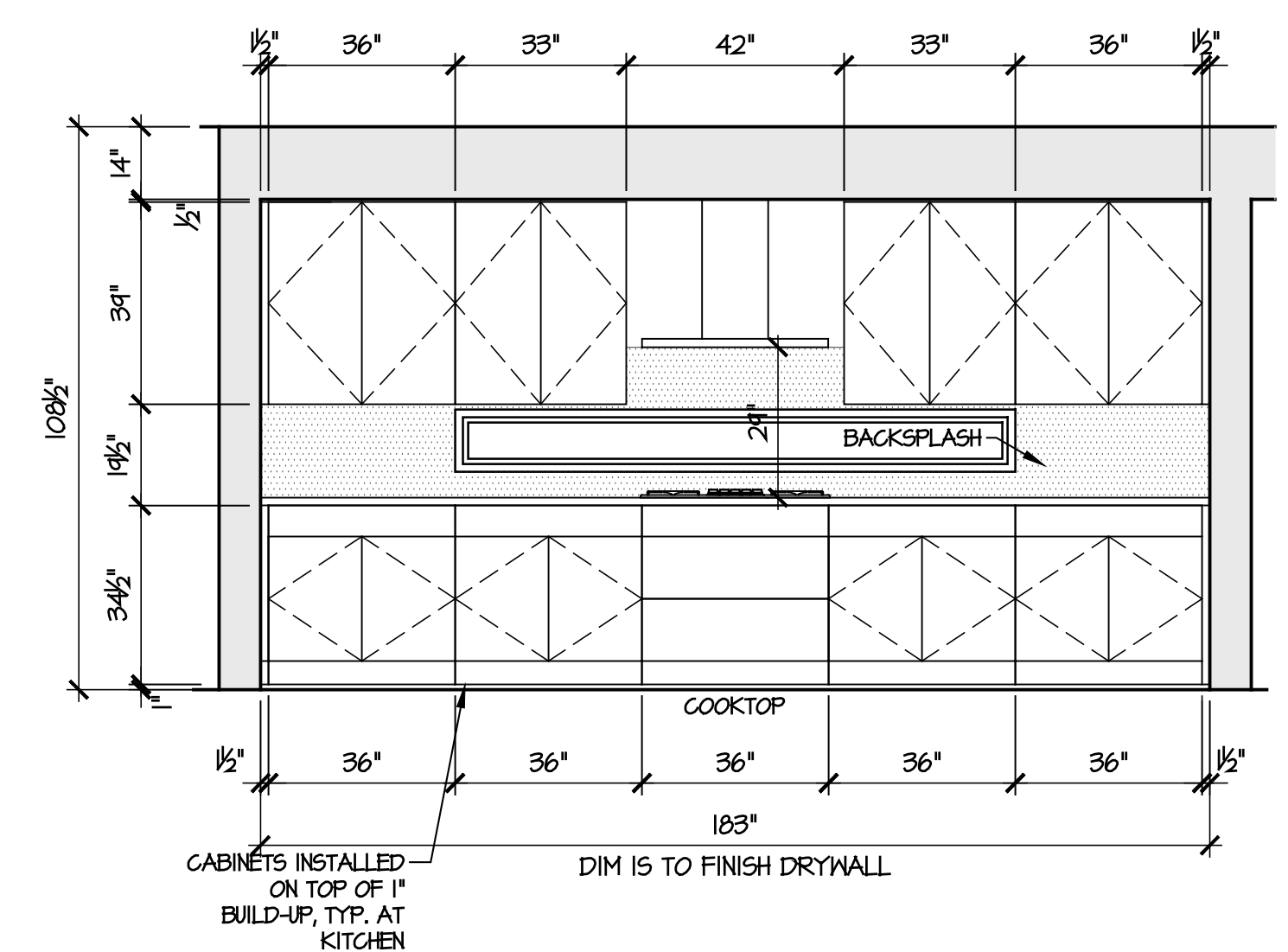

KITCHEN (N.T.S.) 1

KITCHEN (N.T.S.) 2

KITCHEN ISLAND (N.T.S.) 3

KITCHEN ISLAND (N.T.S.) 4

GRAND BUTLER'S PANTRY (N.T.S.) 5

NO.	DATE	DESCRIPTION
1	07/14/20	PERMIT SUBMITTAL (S)

1110 112th Ave NE, Suite 202  
 Bellevue, WA 98004  
 Phone: (425) 646-4022  
 Fax: (425) 646-4024

**MAINVUE**  
 WA, LLC

**LOTUS (62-40-01)**

**INTERIOR ELEVATIONS & DETAILS**

DESIGN: SU DRAWN: JK  
 PLAN No: 62-40-01 XB

**SHEET A11.0**

22x34 - 1/4" = 1'-0"  
 11x17 - 1/8" = 1'-0"

© 2015 Henley Arch Pty, Ltd. All rights reserved.

W:\Seattle\Plan Library\MainVue Plans\Seattle\14\01 Plans\62-40 LOTUS\CAD Files\00 Base Plan\62-40-01 Supplementary Diagrams.dwg, 2/7/2022 3:51:49 PM, Sean Shuttler



W:\Seattle\Plan\_Library\MainVue Plans\62-40 LOTUS\CAD Files\00 Base Plan\62-40-01 Supplementary Diagrams.dwg, 2/7/2022 3:51:50 PM, Sean Shuttler

3 NOT USED (N.T.S.)

2 NOT USED (N.T.S.)

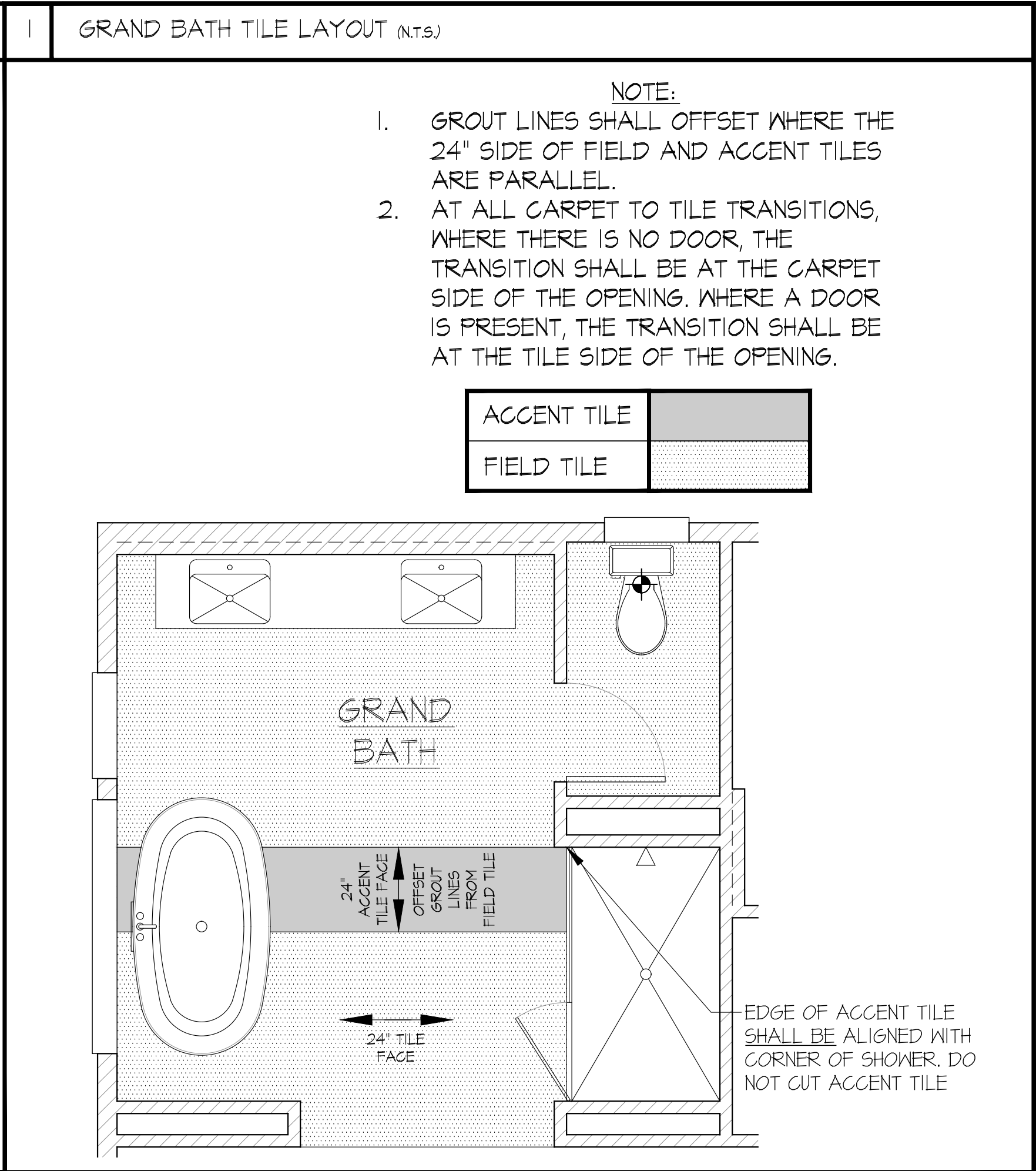

6 NOT USED (N.T.S.)

5 NOT USED (N.T.S.)

4 NOT USED (N.T.S.)

APPROVED  
 Plans Reviewed by **SAFEbuilt** WASHINGTON  
 For Building Code Compliance  
 Reviewed By: **Bobby Thomas** CBO, Plans Examiner,  
 Combination Inspector  
 Date: **7/20/2023 REV 1**

DESCRIPTION	
No.	DATE
1	07-14-20
2	
3	
4	

1110 112th Ave NE, Suite 202  
 Bellevue, WA 98004  
 Phone: (425) 646-4022  
 Fax: (425) 646-4024

**MAINVUE**  
 WA, LLC

LOTUS (62-40-01)

TILE AND PANTRY LAYOUTS

DESIGN:	DRAWN:
SU	JK
PLAN No:	
62-40-01 XB	

SHEET  
**A12.0**

22x34 - 1/4" = 1'-0"  
 11x17 - 3/8" = 1'-0"

© 2015 Henley Arch Pty, Ltd. All rights reserved.



**APPROVED**  
 Plans Reviewed by **SAFEbuilt**  
 For Building Code Compliance  
 Reviewed By:  
**Bobby Thomas CBO, Plans Examiner,**  
 Combination Inspector  
 Date:  
**7/20/2023 REV 1**

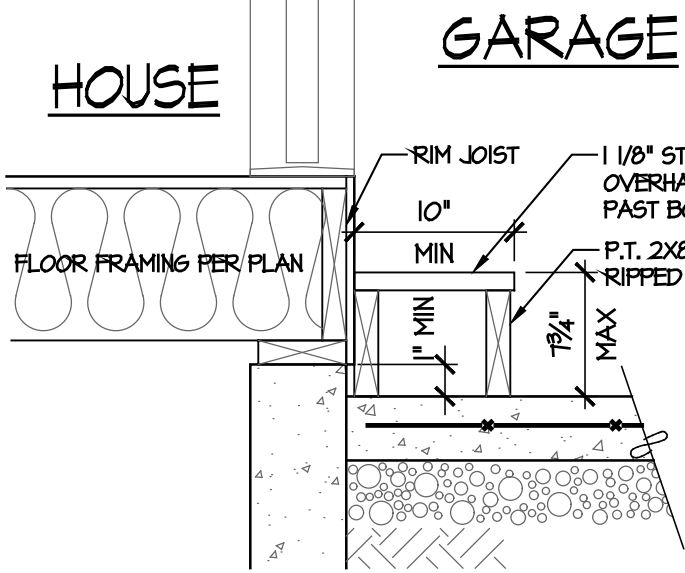

15 GARAGE TO HOUSE STEP DETAIL

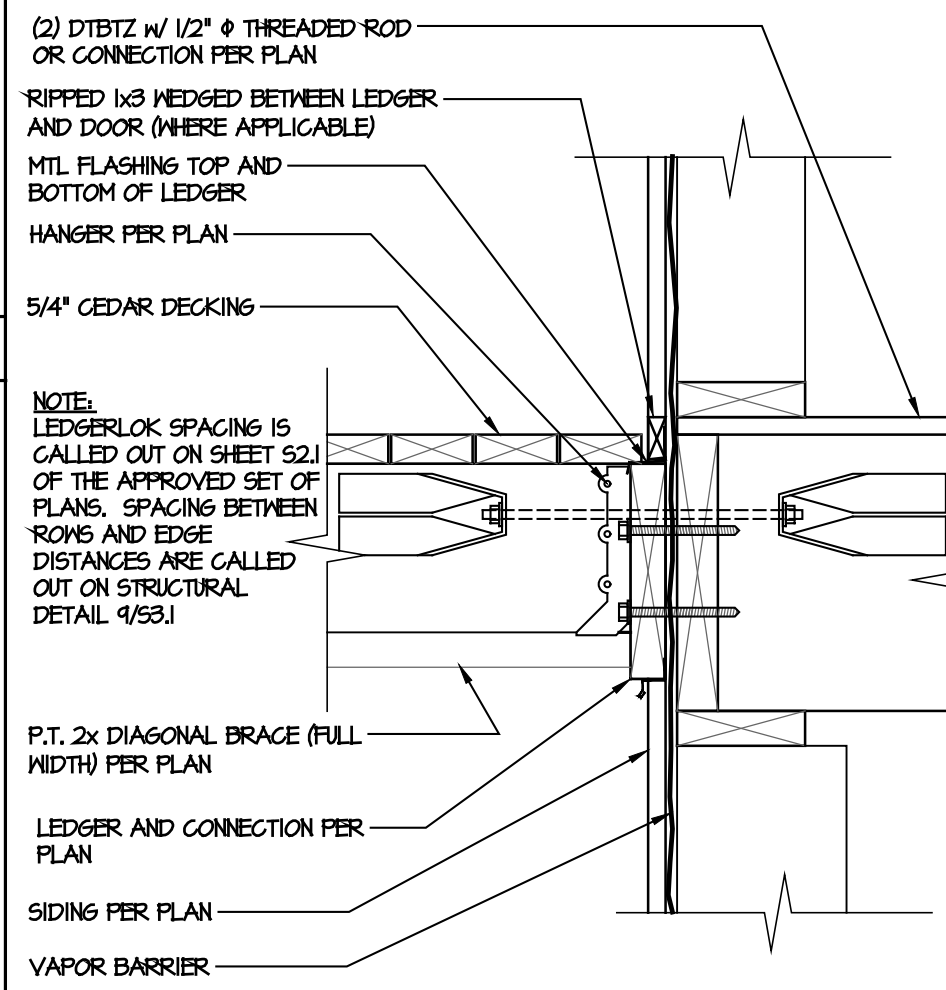

14 DECK DETAIL (LEDGER TO WALL/ DOOR)

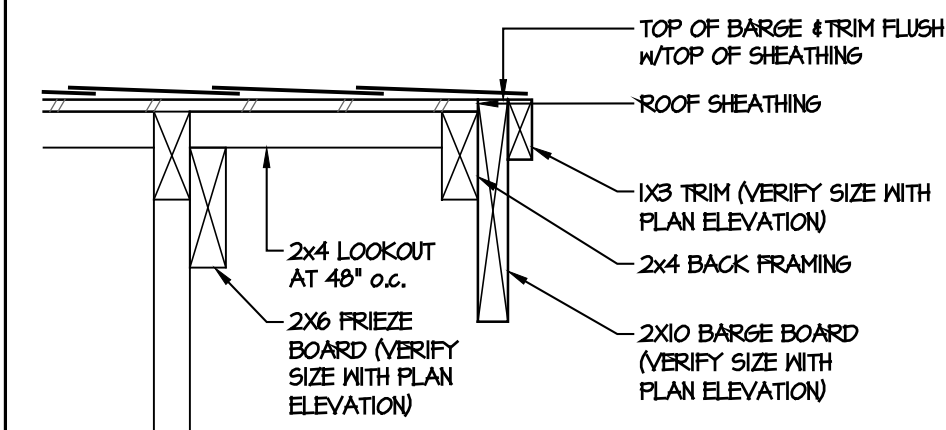

13 BARGE BOARD DETAIL

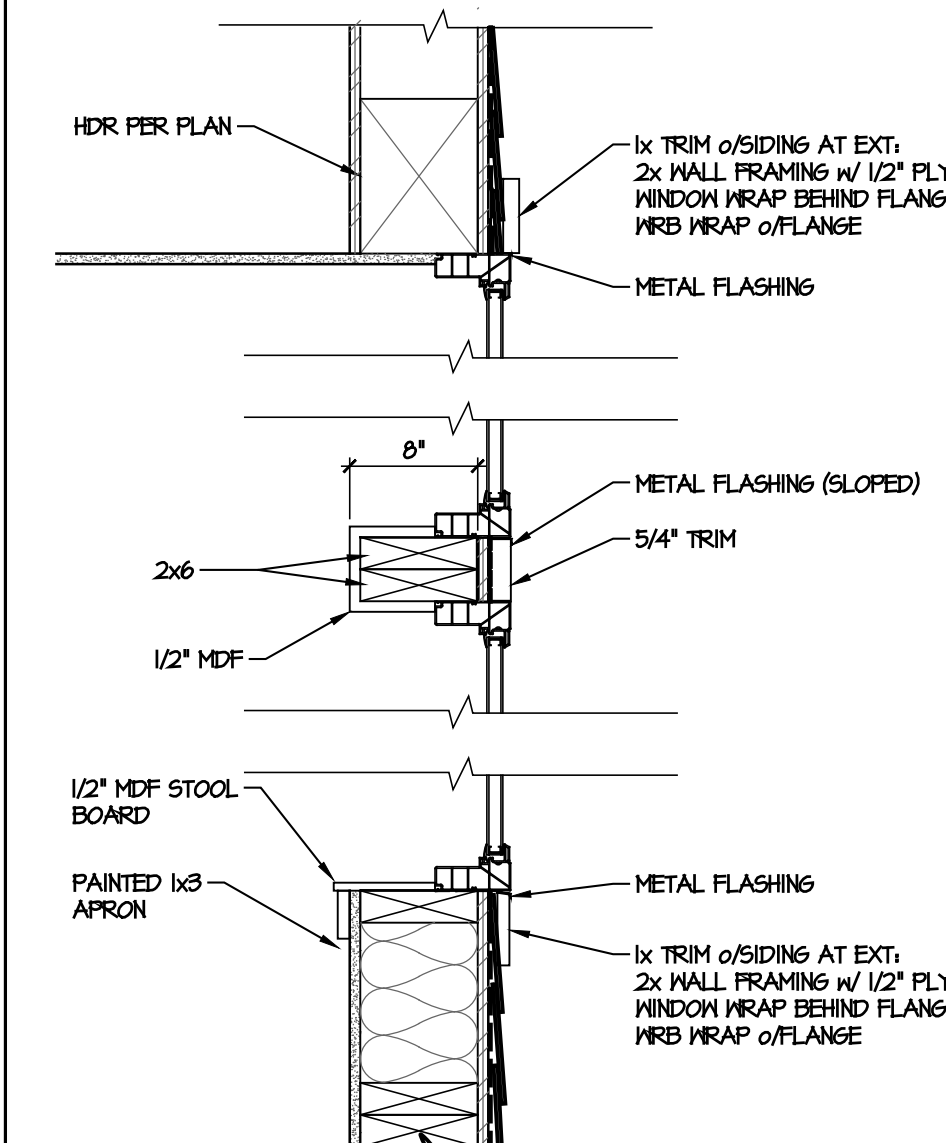

12 2x6 WALL w/TRANSOM

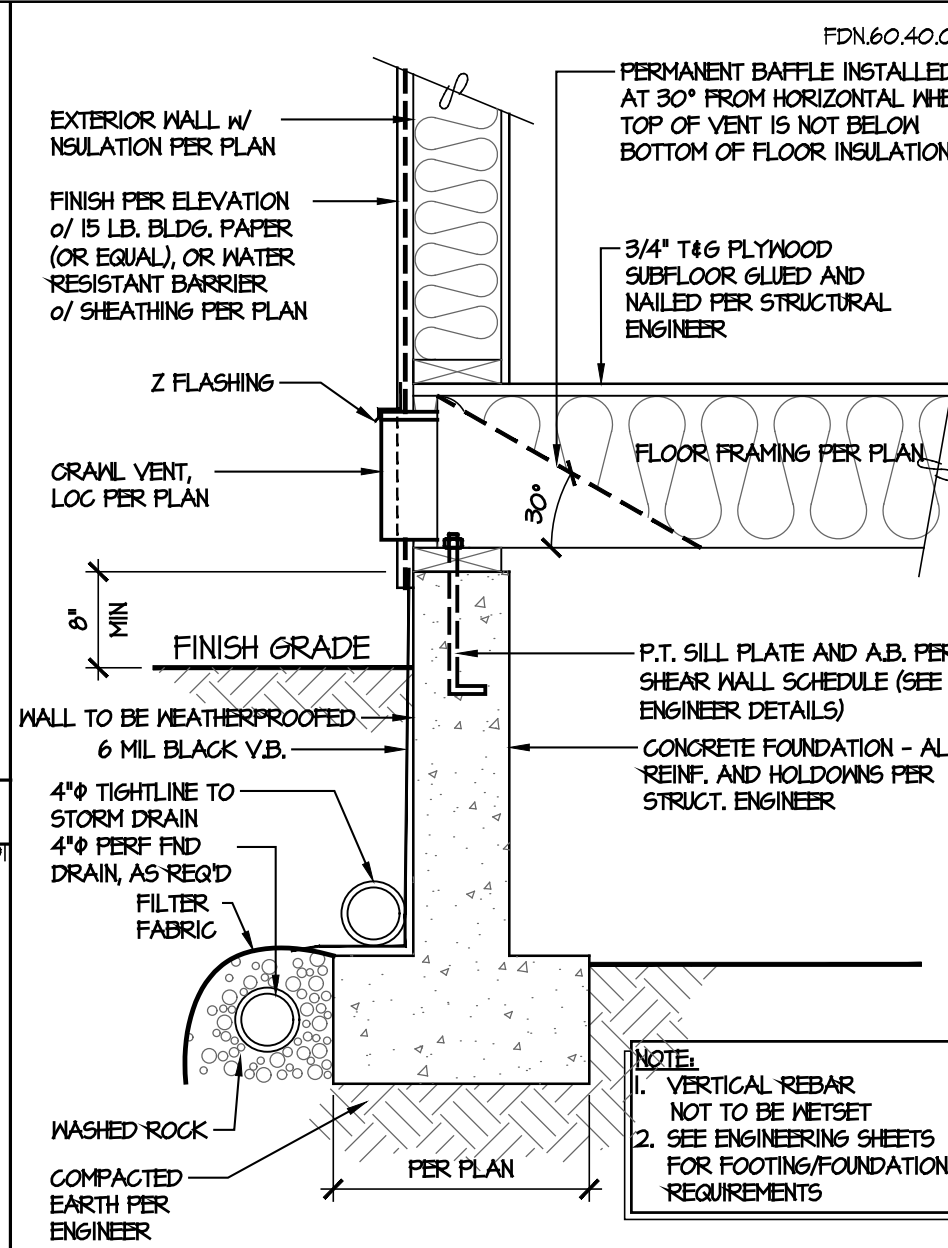

11 TYPICAL 6" FOUNDATION WALL

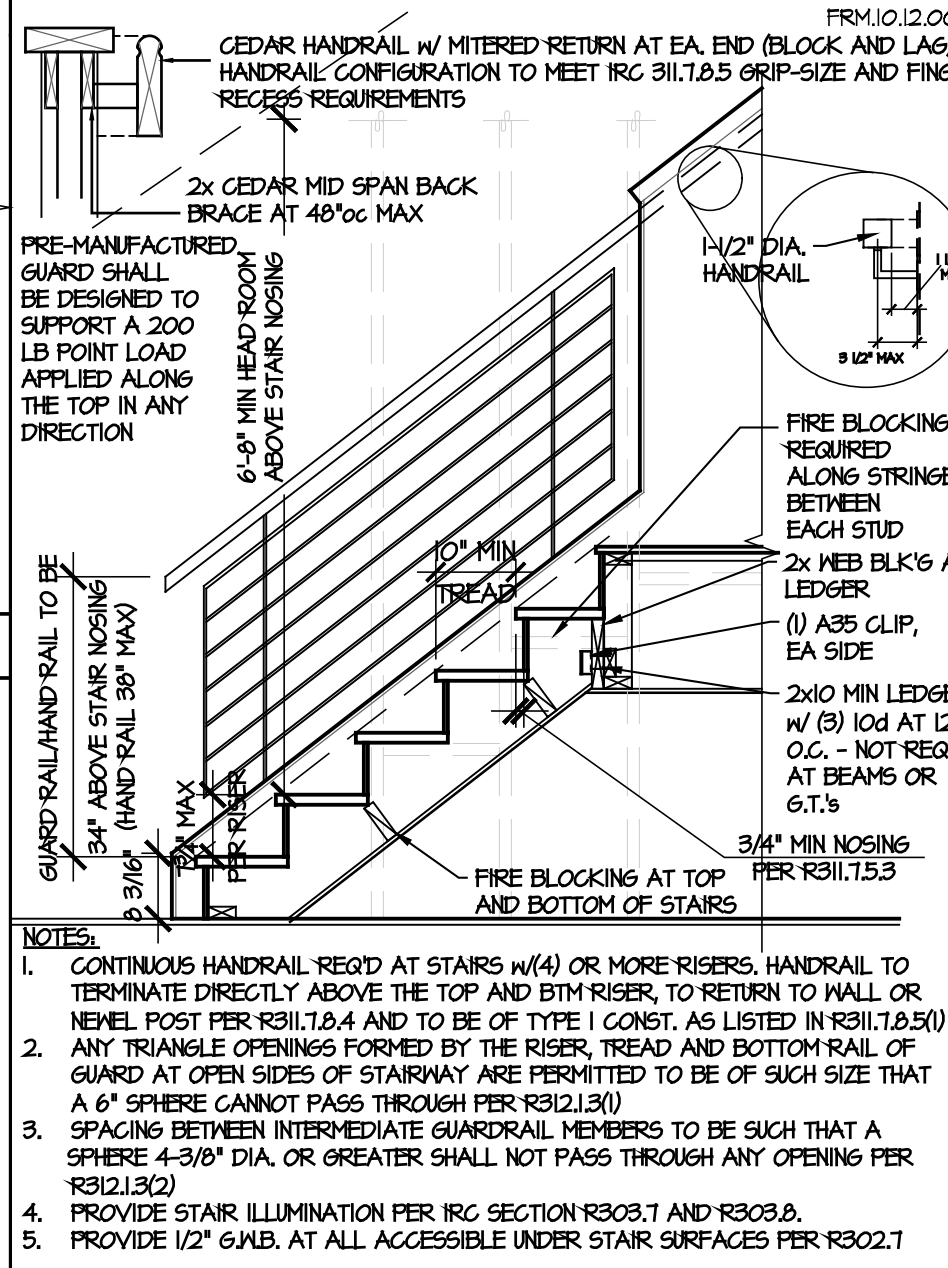

10 TYPICAL INTERIOR STAIRS

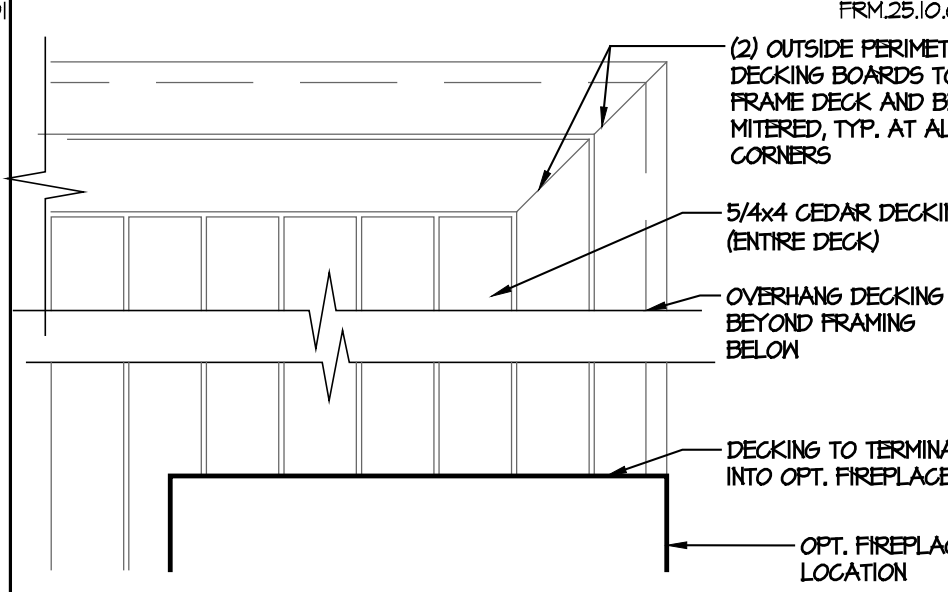

9 PICTURE FRAME DECK

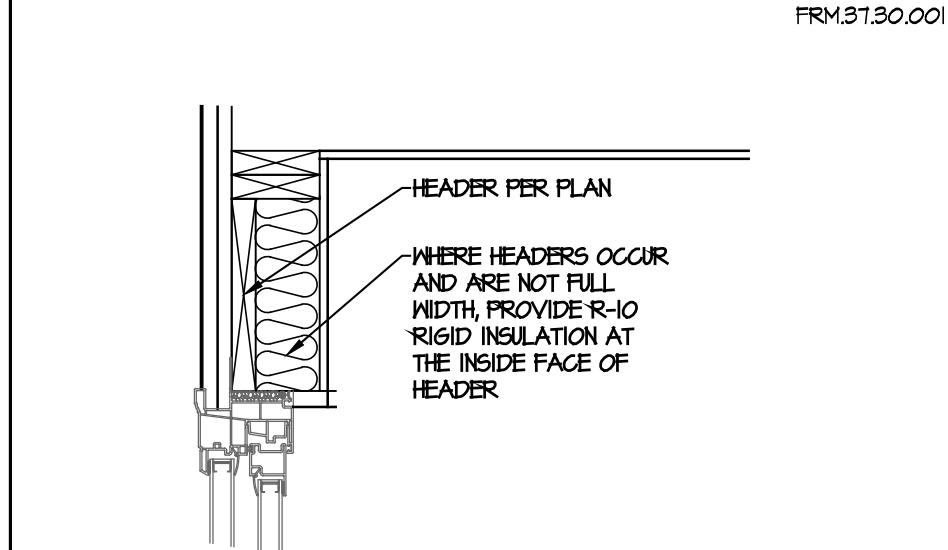

8 INSULATED HEADER

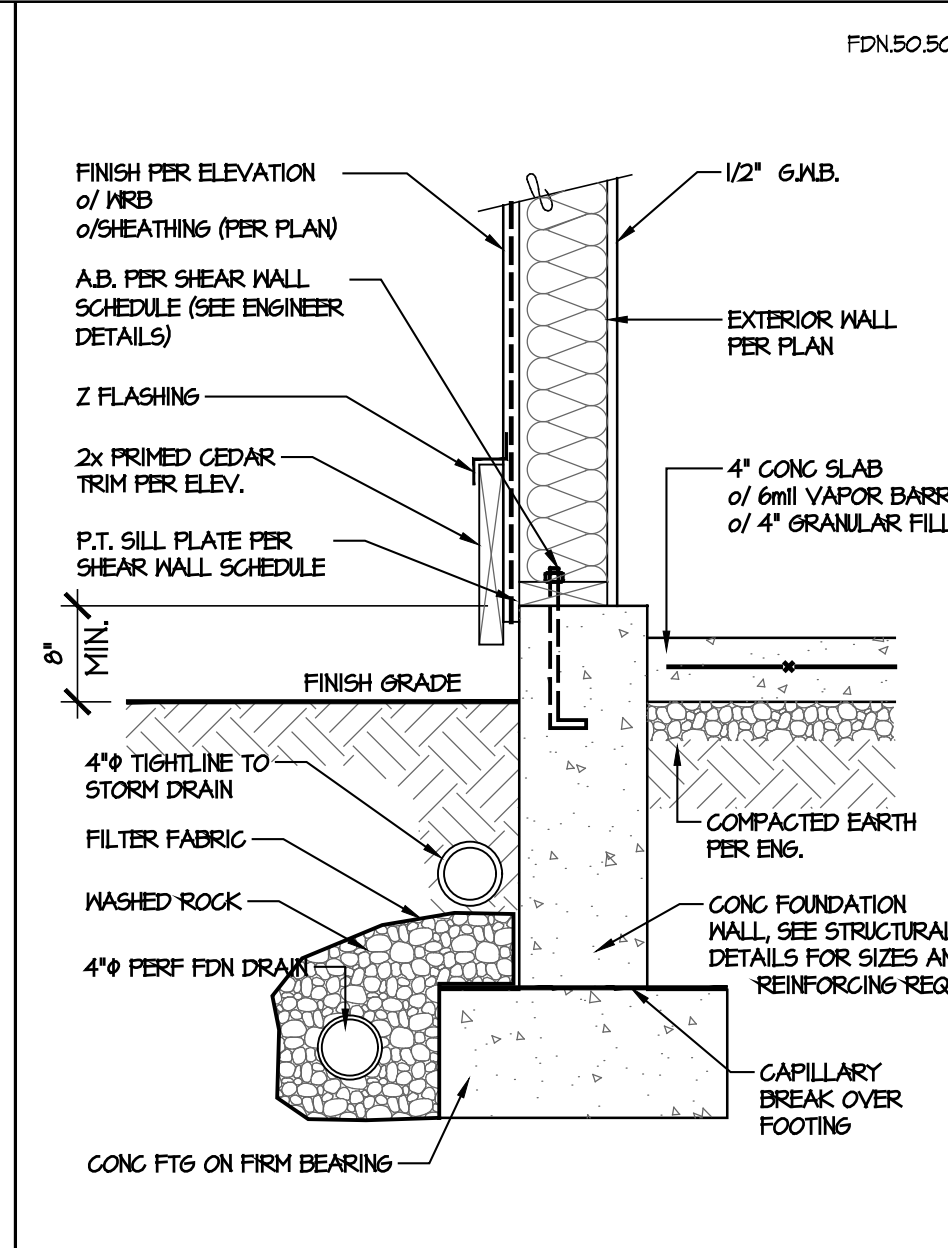

6 FOUNDATION WALL SECTION - GARAGE

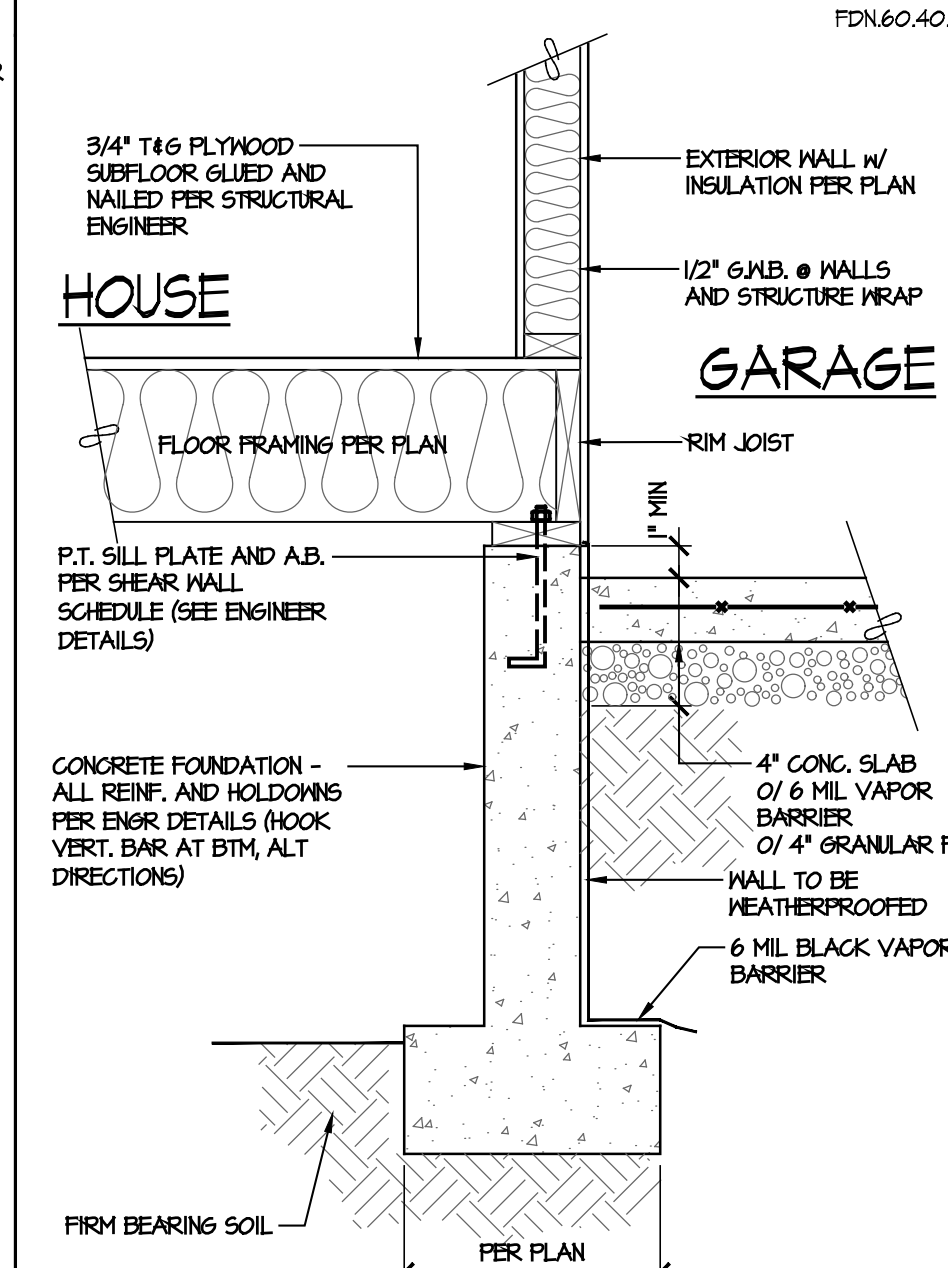

5 FOUNDATION WALL SECTION - HOUSE/GARAGE

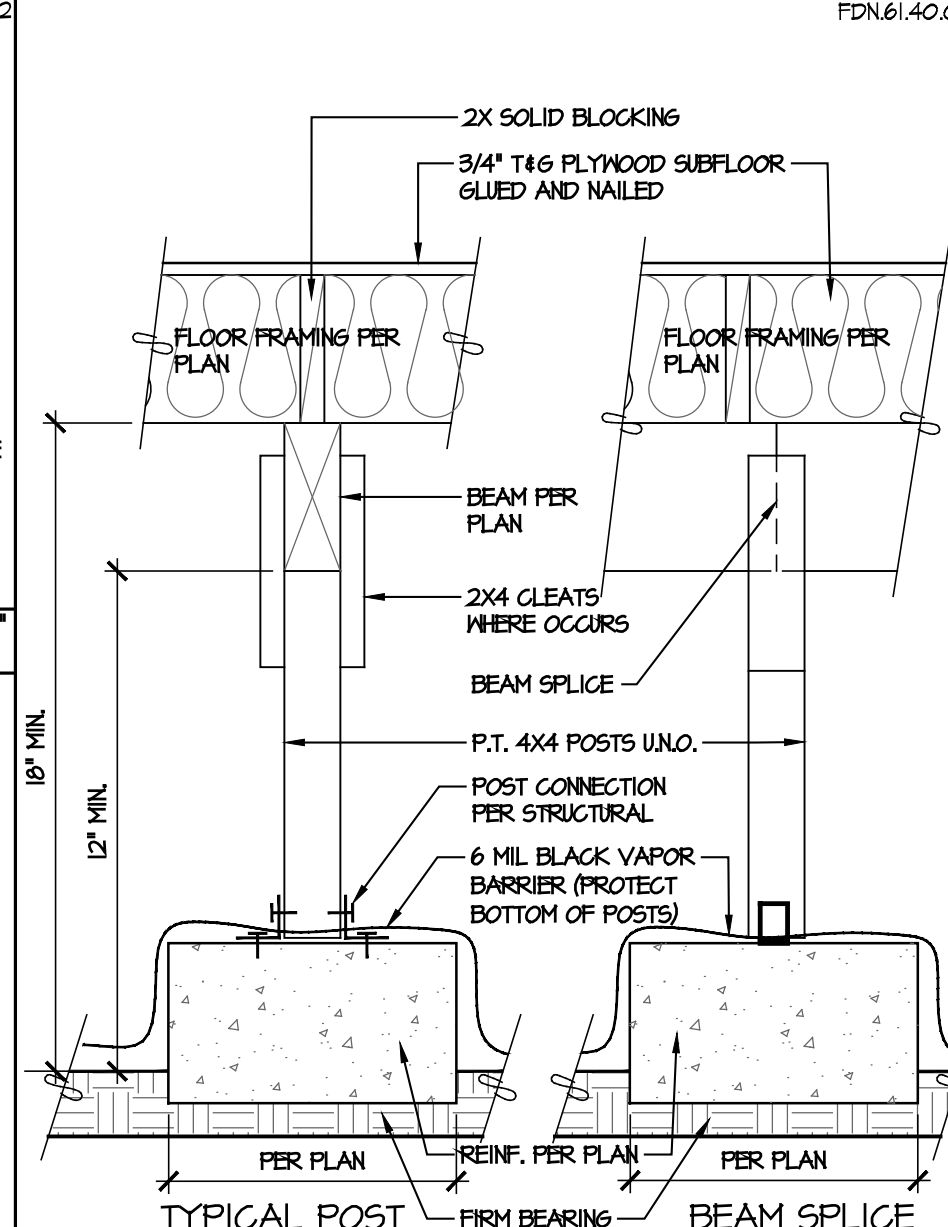

4 TYPICAL ISOLATED FOOTING

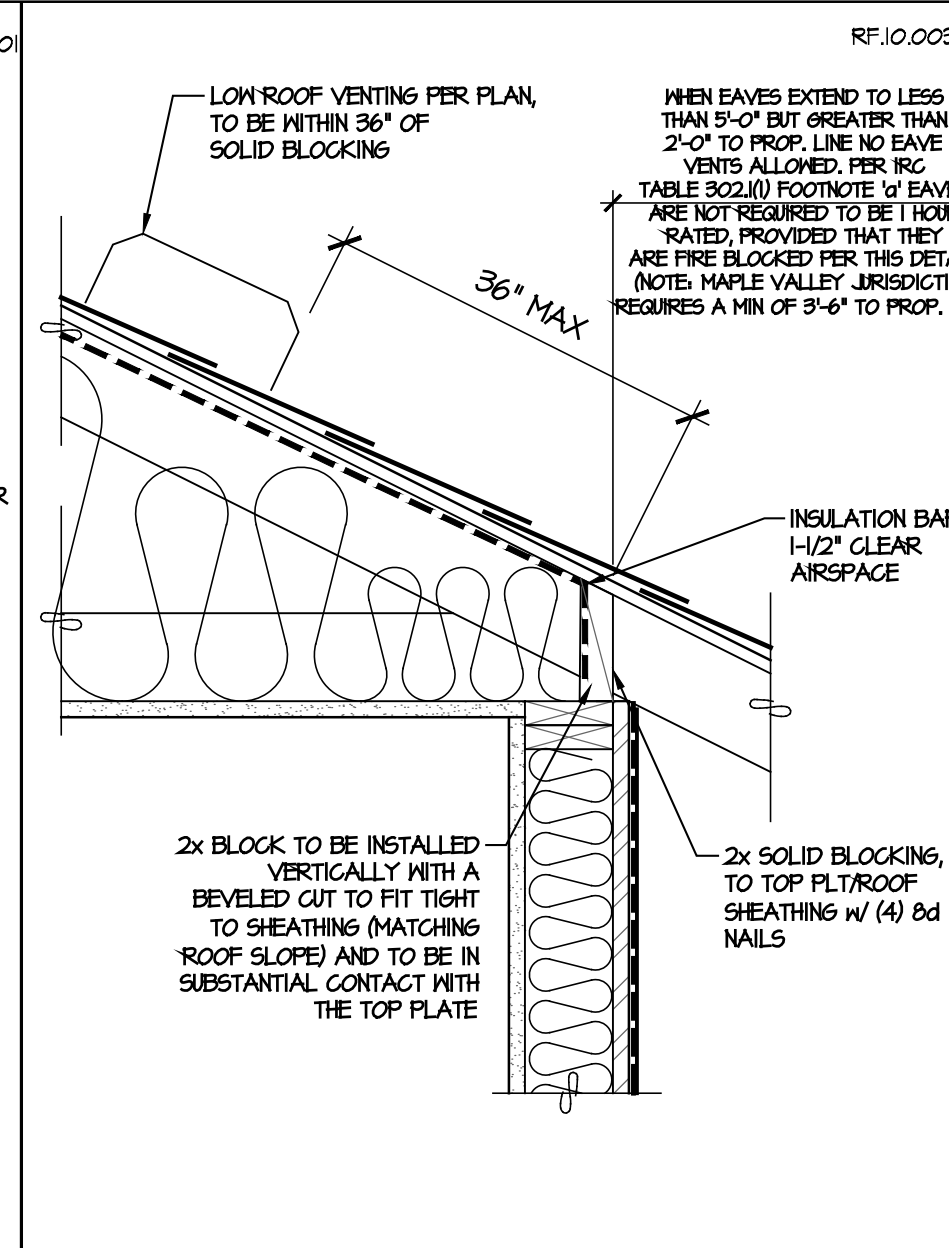

3 FIREBLOCK AT EAVE

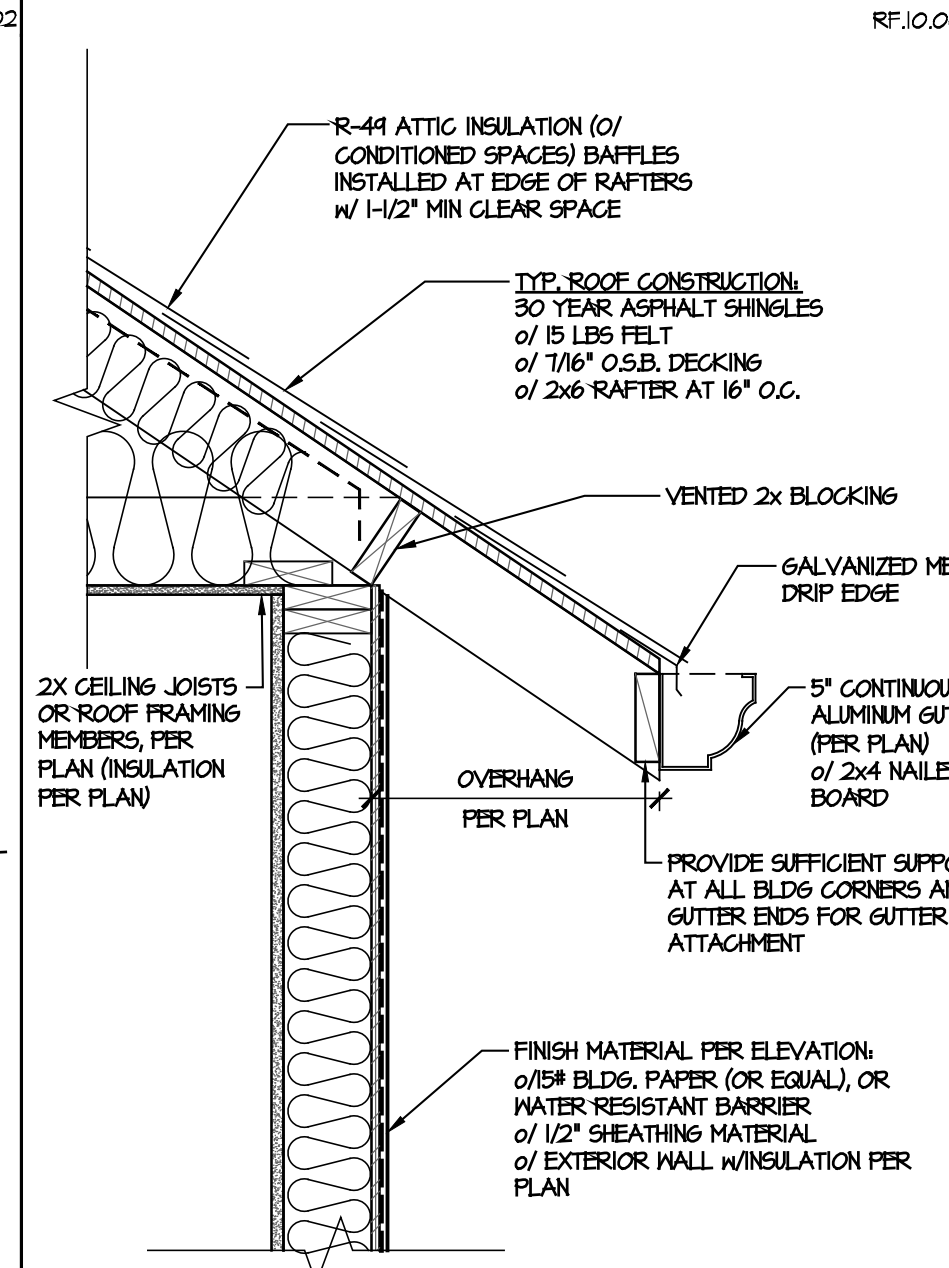

2 TYPICAL ROOF EAVE

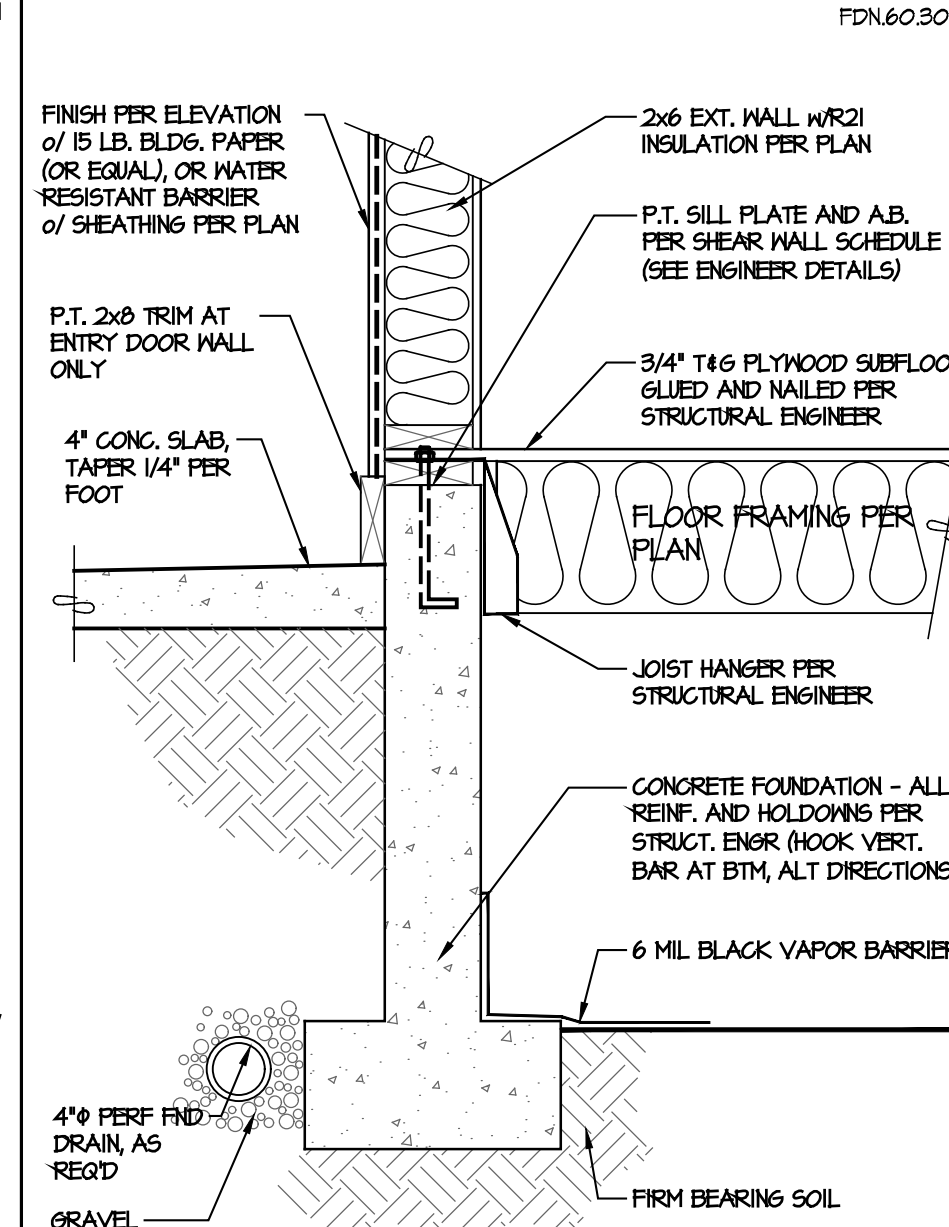

1 PORCH SLAB/FOUNDATION

21 NOT USED

18 NOT USED

20 NOT USED

17 NOT USED

19 NOT USED

16 INT STAIRS - STRINGER TO LANDING

DESCRIPTION	
5 III - UPDATED SHEET	REVISE LAYOUT & DETAILS
DATE: 4/19/16	10/12/16
DATE: 9/29/22	REVISE STAIR DETAIL
No. 1	1
No. 2	1
121 3rd Ave Kirkland, WA 98033 Phone: (425) 646-4024 Fax: (425) 646-4024	
<b>MAINVUE</b> WA, LLC	
<b>STANDARD DETAILS</b>	
<b>MULTI-STORY</b> DETAILS	
DESIGN:	DRAWN:
PLAN No: DETAIL SHEETS	
<b>SHEET</b> <b>D1.0</b>	
22x34 - 1/4" = 1'-0" 11x17 - 1/8" = 1'-0"	







16	12	8		
15	11	7		
14	10	6		
13	9	5		

**APPROVED**  
 Plans Reviewed by **SAFEbuilt**  
 For Building Code Compliance  
 Reviewed By:  
**Bobby Thomas** CBO, Plans Examiner,  
 Combination Inspector  
 Date:  
**7/20/2023 REV 1**

DESCRIPTION	DETAILS - HVAC INSULATION (TD)
DATE	6-20-22
No.	1
No.	1
No.	1
<b>STANDARD DETAILS</b> <b>STANDARD PLAN</b> <b>DETAILS II</b>	
DESIGN:	DRAWN:
PLAN No:	DETAIL SHEETS
<b>SHEET</b> <b>D1.2</b>	
22x34 - 1/2" = 1'-0" 11x17 - 1/8" = 1'-0"	

**MAINVUE**  
**WA, LLC**  
 121 3rd Ave  
 Kirkland, WA 98033  
 Phone: (425) 846-4024  
 Fax: (425) 846-4024



APPROVED  
 Plans Reviewed by SAFEbuilt WASHINGTON  
 For Building Code Compliance  
 Reviewed By:  
 Bobby Thomas CBO, Plans Examiner,  
 Combination Inspector  
 Date:  
 7/20/2023 REV 1

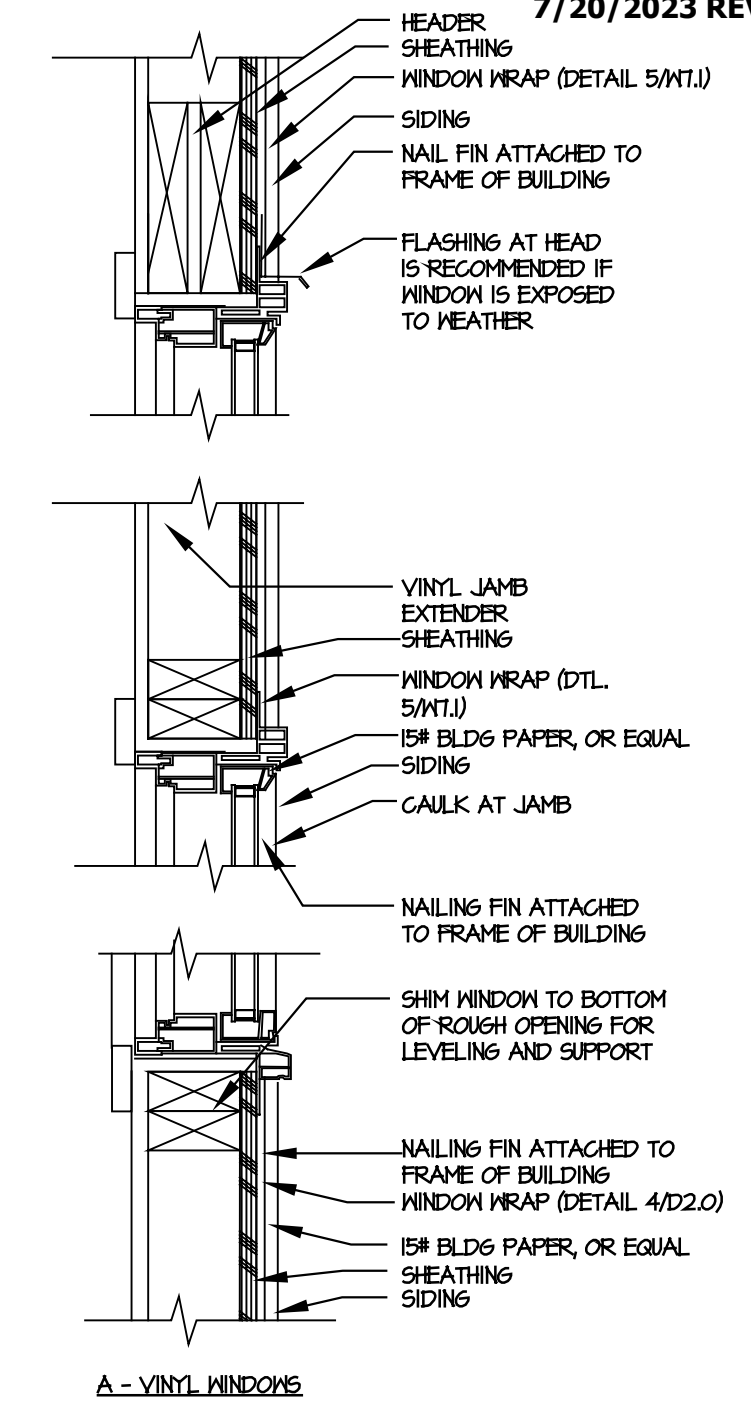
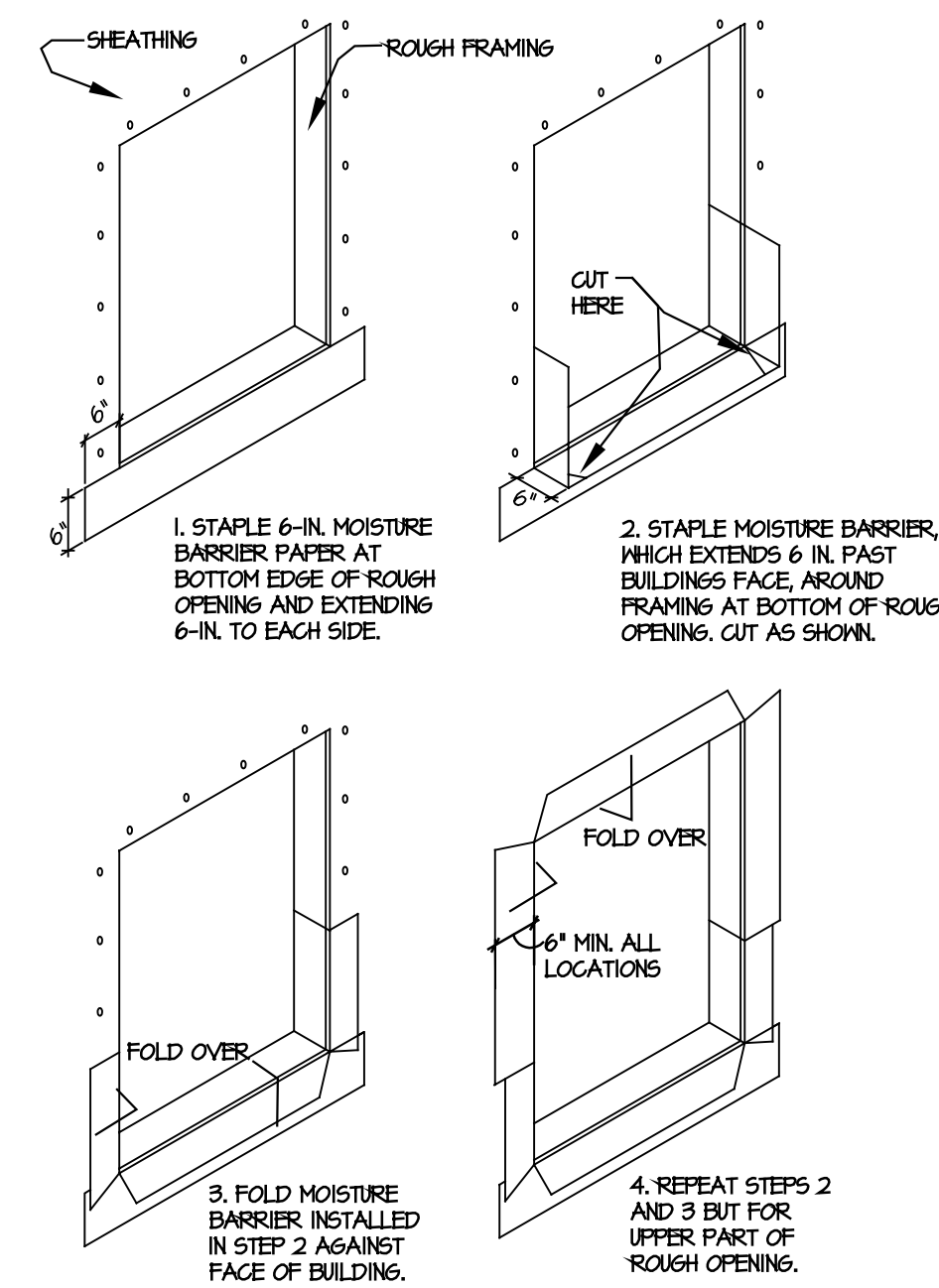

10 NOT USED SCALE: N.T.S.

7 NOT USED SCALE: N.T.S.

4 WINDOW / DOOR ROUGH OPENING SCALE: N.T.S.

2 FLASHING AT EXTERIOR WINDOWS SCALE: N.T.S.

9 NOT USED SCALE: N.T.S.

6 JAMB SCALE: N.T.S.

3 BITUTHENE DOOR PAN SCALE: N.T.S.

1 WINDOW DETAILS SCALE: N.T.S.

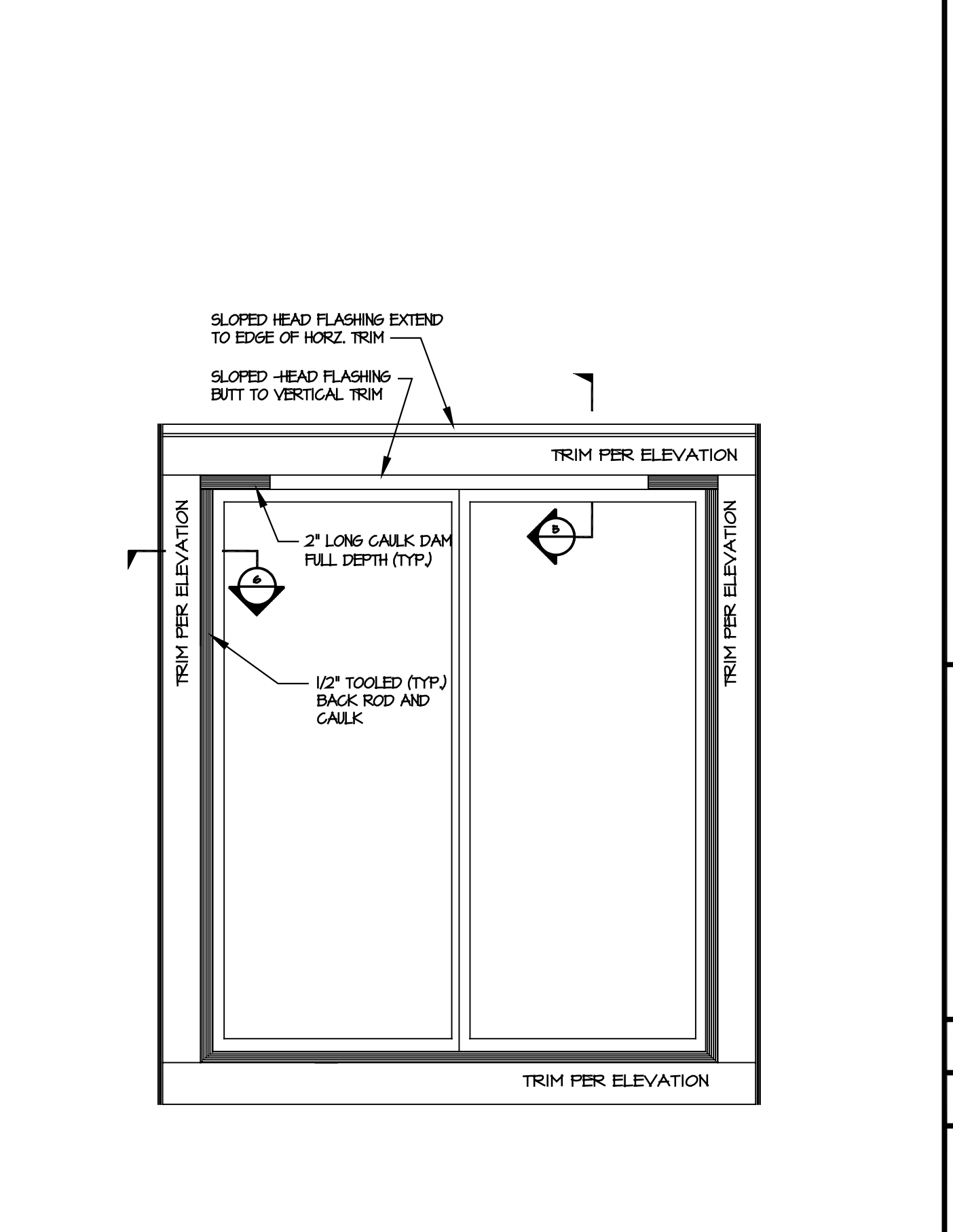
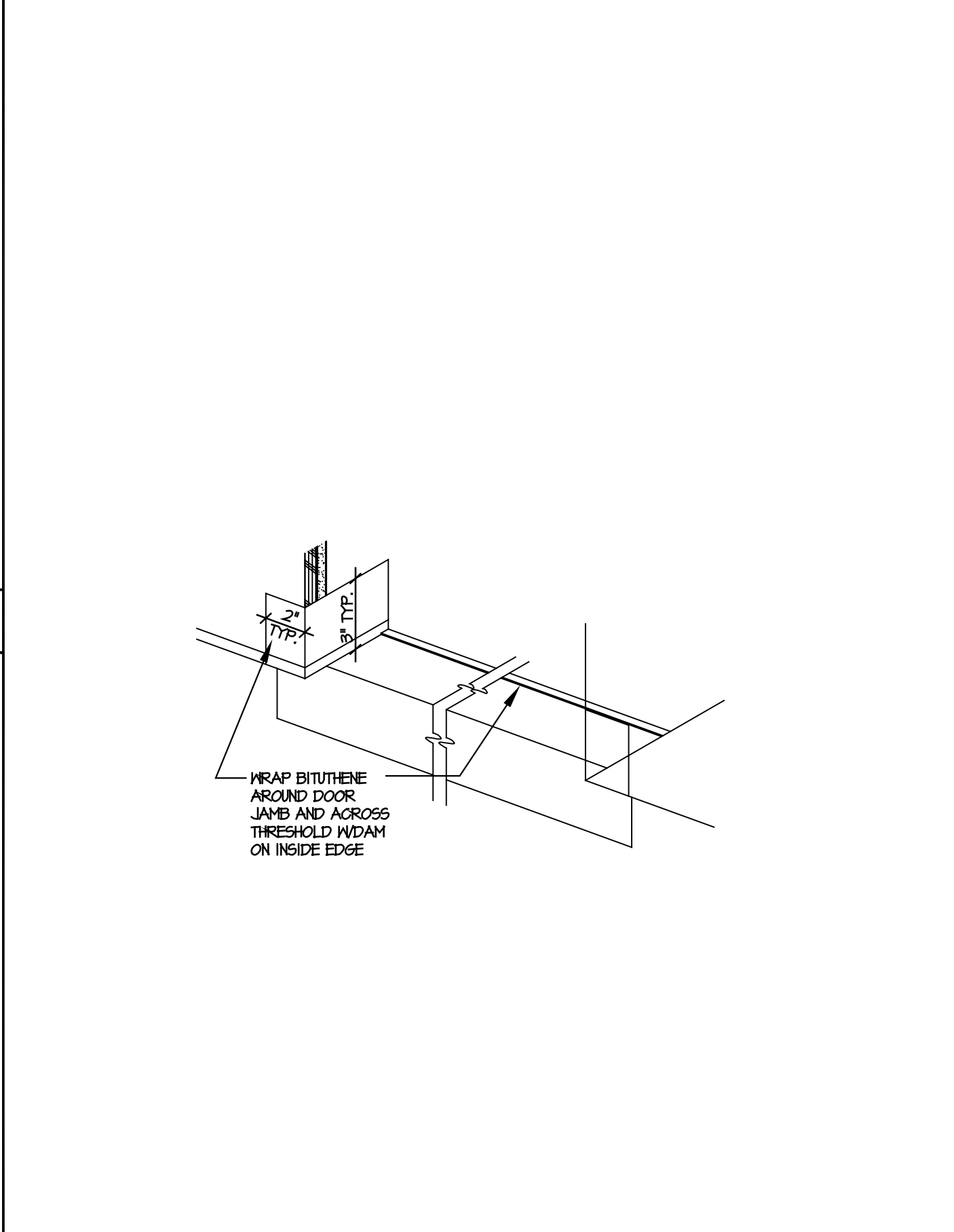
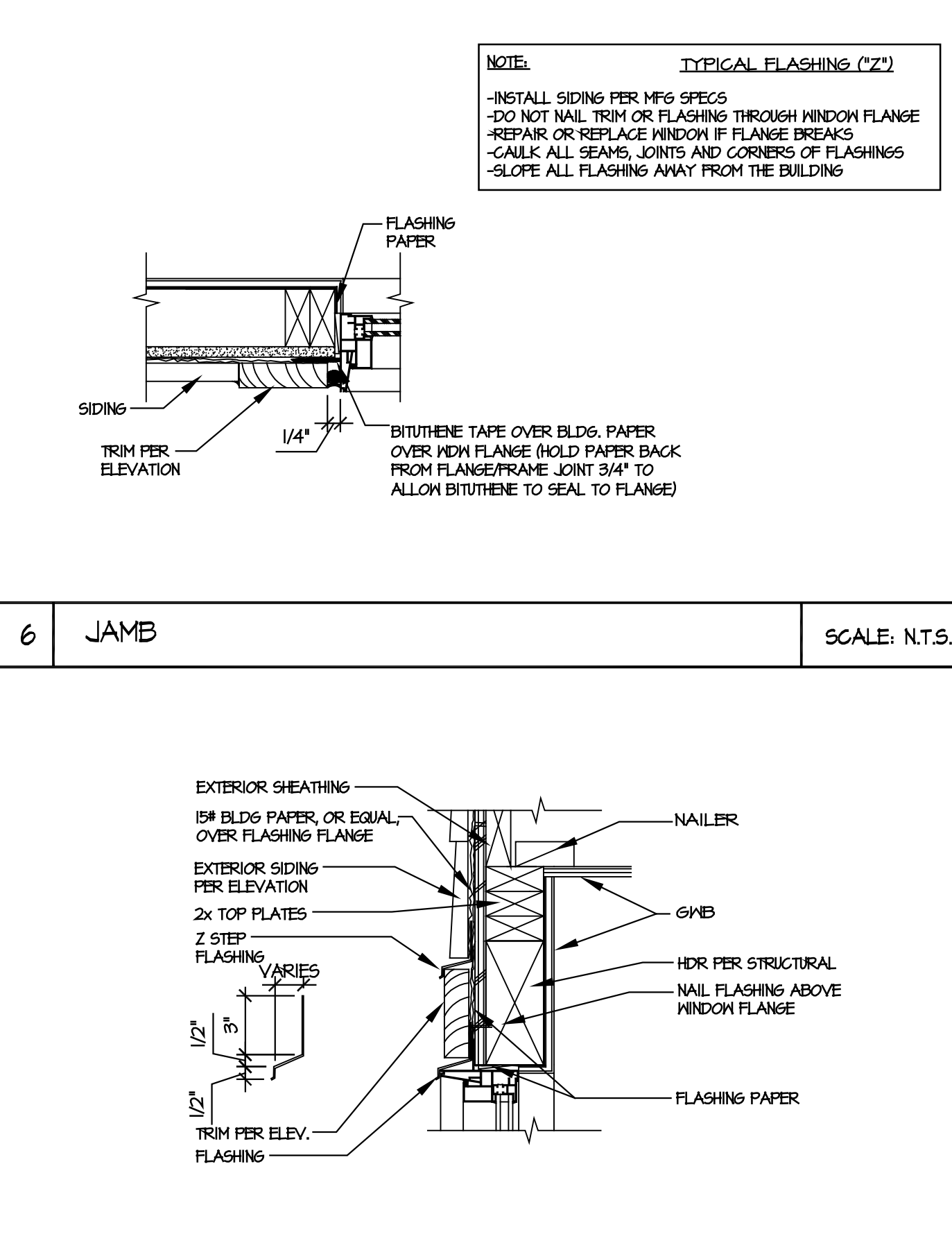
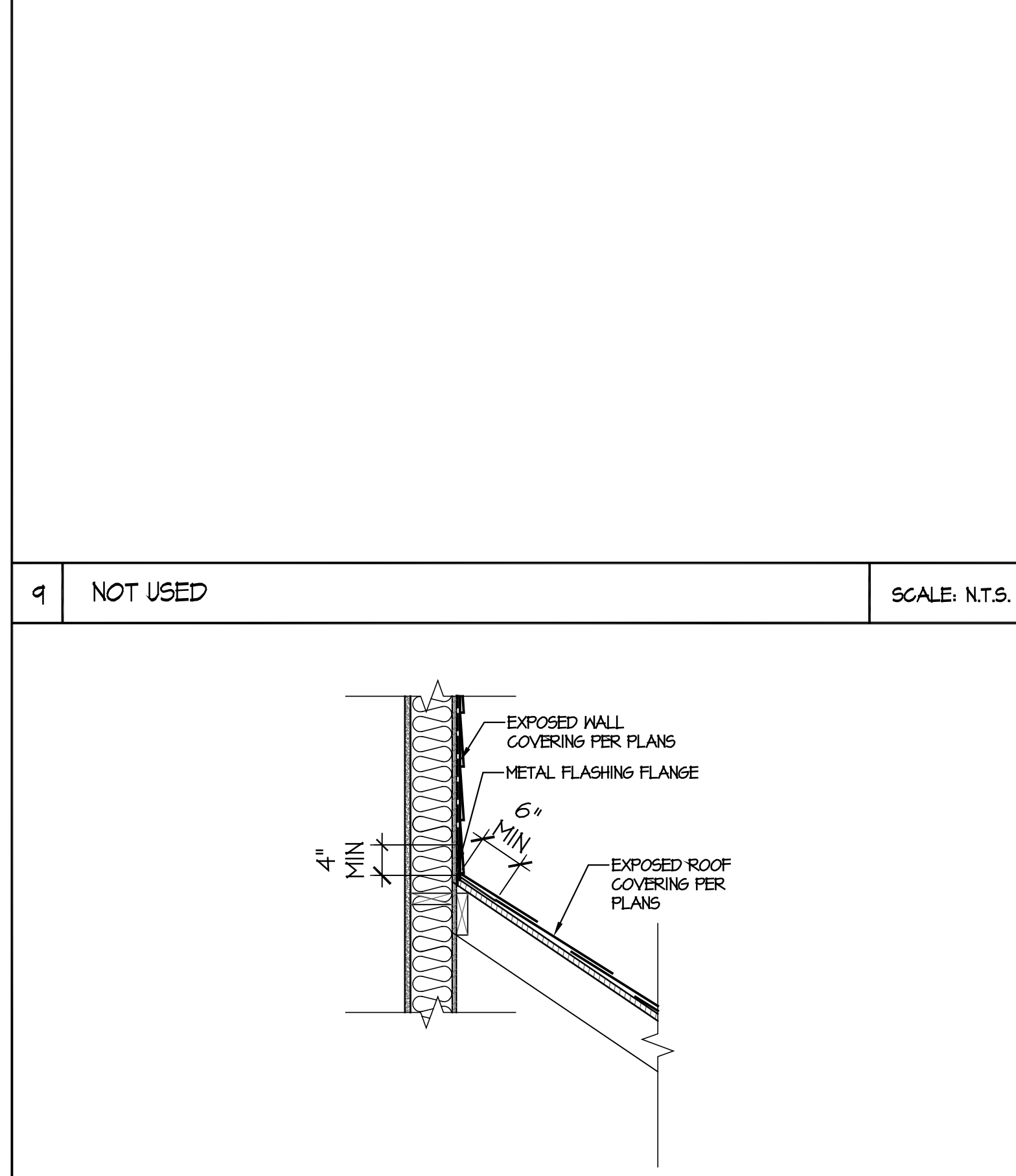

8 TYPICAL ROOF TO WALL FLASHING SCALE: N.T.S.

5 HEAD SCALE: N.T.S.

3 BITUTHENE DOOR PAN SCALE: N.T.S.

1 WINDOW DETAILS SCALE: N.T.S.

No.	DATE	DESCRIPTION

121 3rd Ave  
 Kent, WA 98032  
 Phone: (425) 646-4022  
 Fax: (425) 646-4024

**MAINVUE**  
 WA, LLC

STANDARD DETAILS

WATER INTRUSION DETAILS

DESIGN: JB DRAWN: -  
 PLAN No: D1.1  
**SHEET D2.0**  
 22x34 - 1/8" = 1'-0"  
 11x17 - 1/8" = 1'-0"



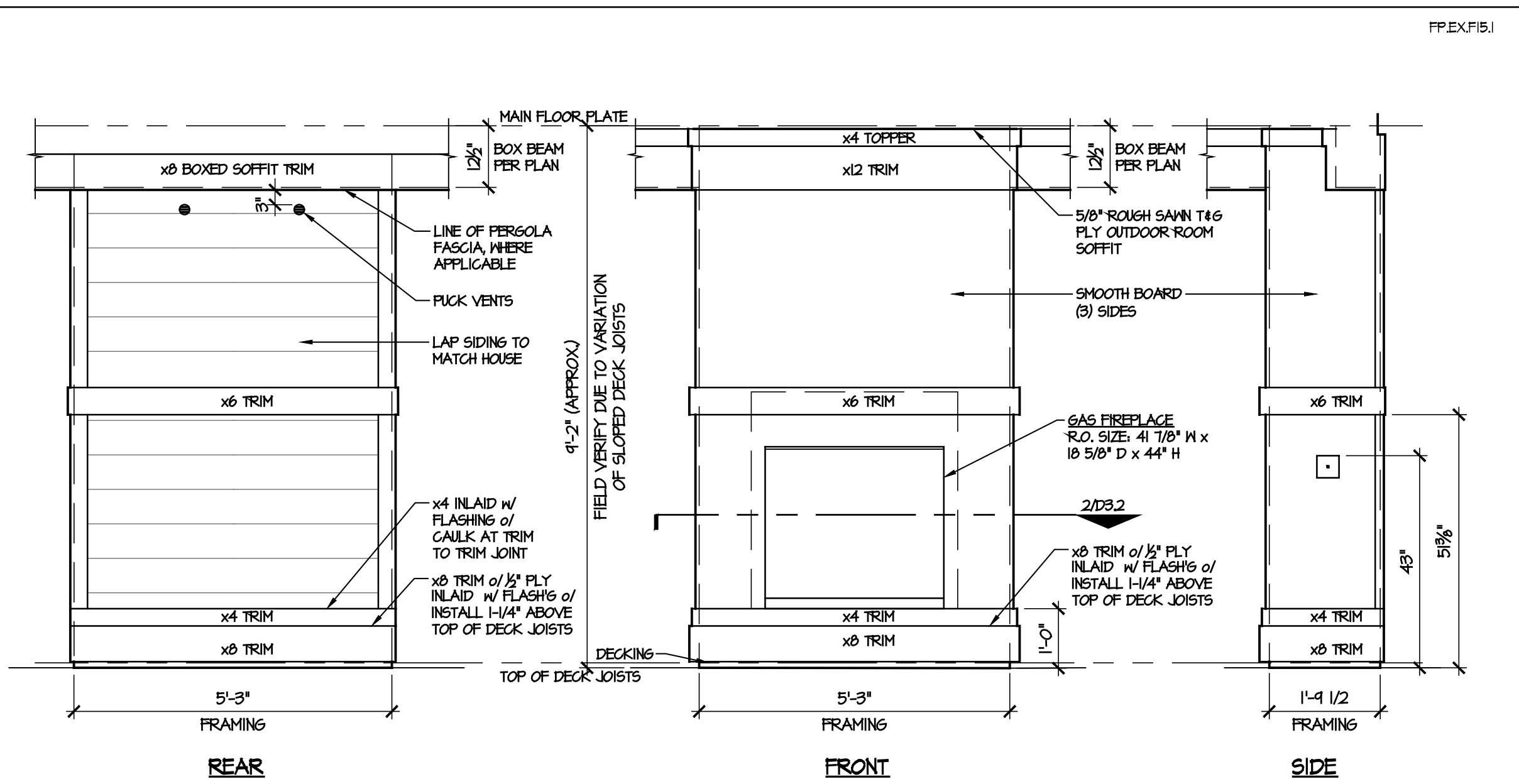

8 SMOOTH BOARD FIREBOX FULL HEIGHT ELEVATION 1/2"

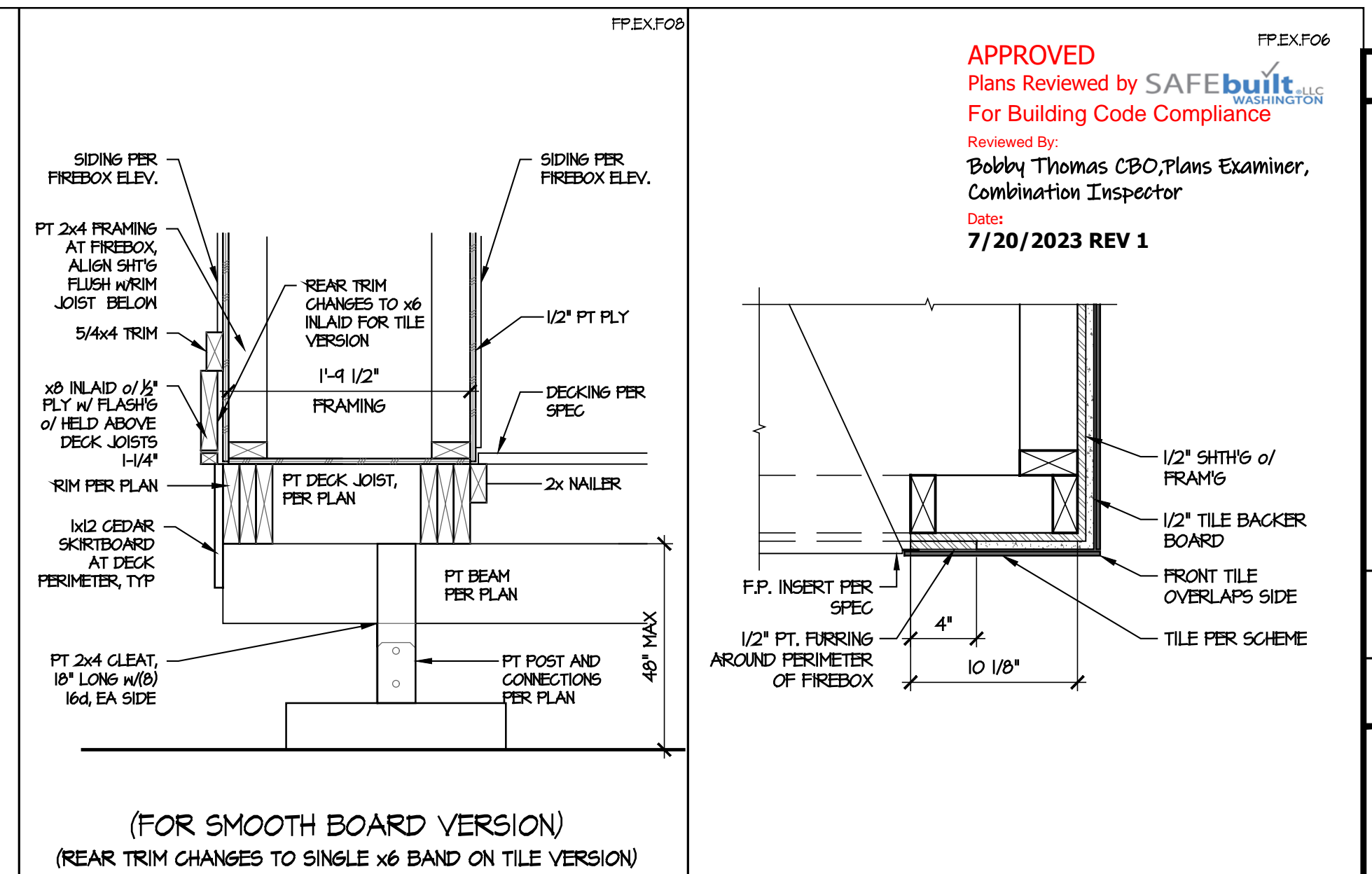

5 PARALLEL FIREBOX DECK FRAMING 1" 3 TILE FIREBOX FURRING DETAIL 1-1/2"

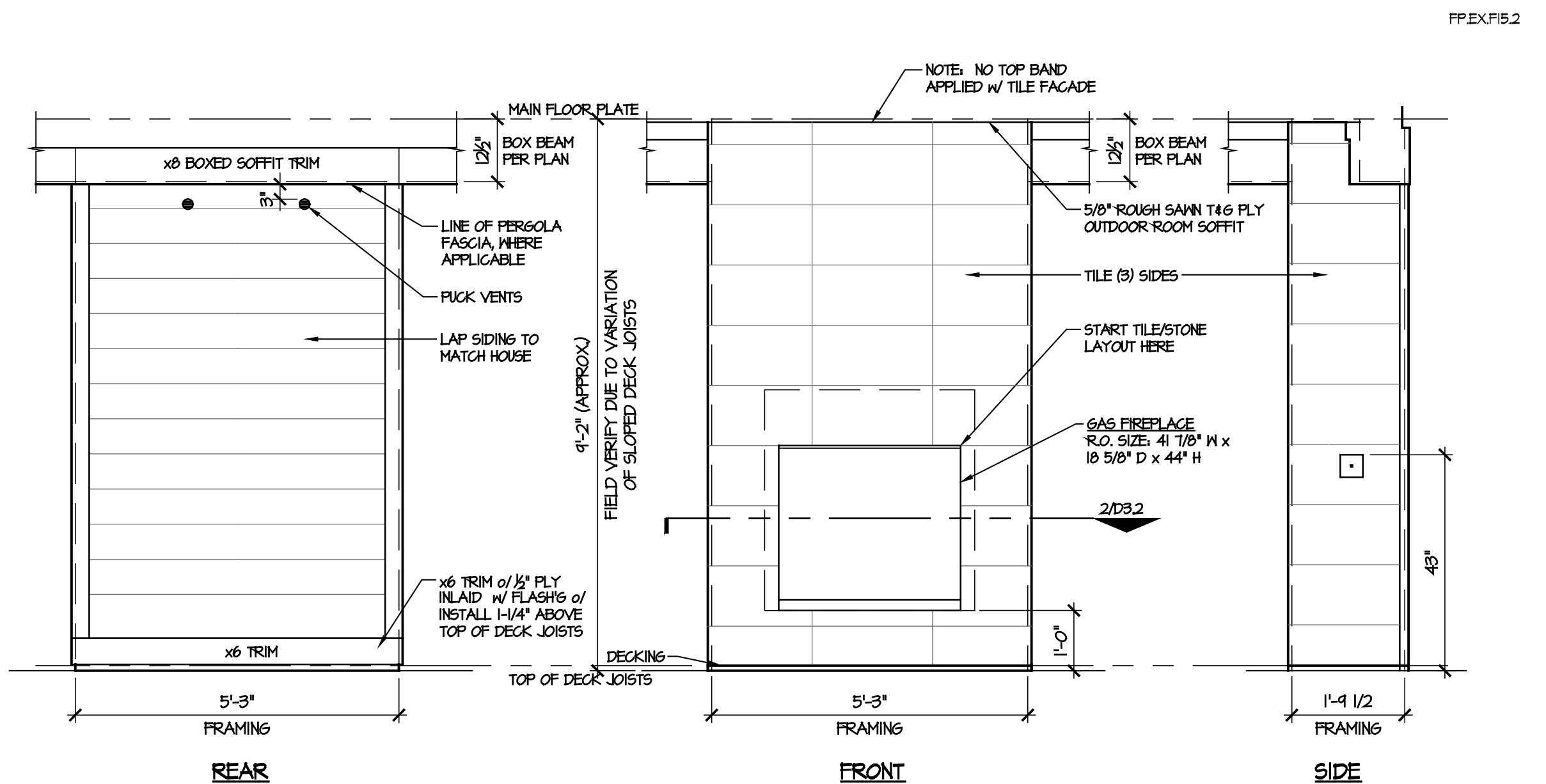

9 TILE FIREBOX FULL HEIGHT ELEVATION 1/2"

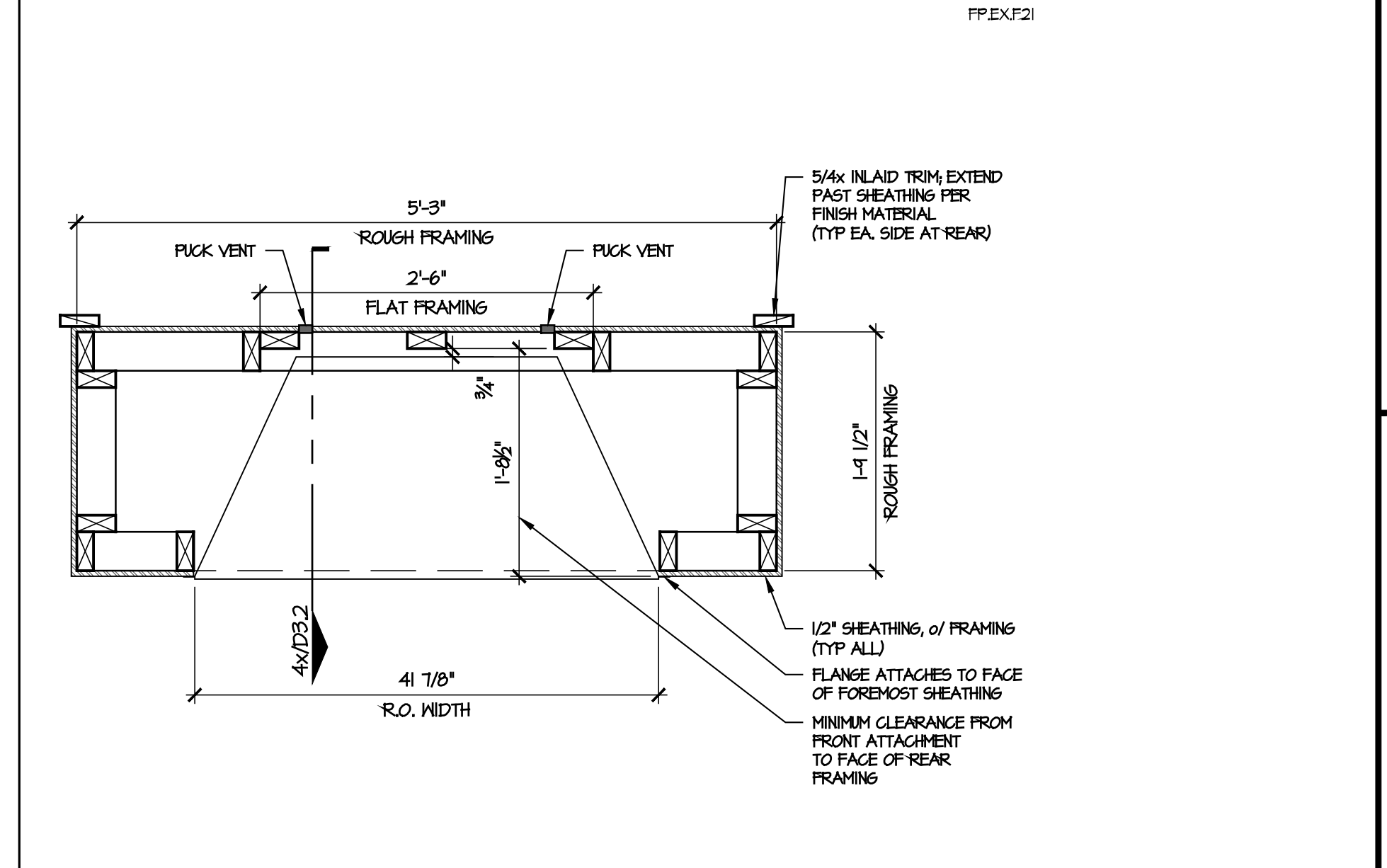

2 FIRE BOX ROUGH FRAMING 1"

FP.EXF01

**FIREPLACE INFORMATION**

NOTE: MATERIAL BEHIND MASONRY TO BE P.T. PLYWOOD TYP U.N.O.

NOTE: FIREPLACE - D.V. F/P TO BEAR STAMP OF U.L. PR I.C.C. TESTING LAB. INSTALL PER MFG SPECS

**OUTDOOR ROOM OPTIONAL FIREPLACE NOTES:**

IGNITOR SWITCH TO BE INSTALLED CENTERED ON THE RIGHT SIDE OF THE FIREPLACE BOX AT 46" A.F.F. TO TOP OF ELEC. BOX.

GENERAL FIREPLACE INFORMATION

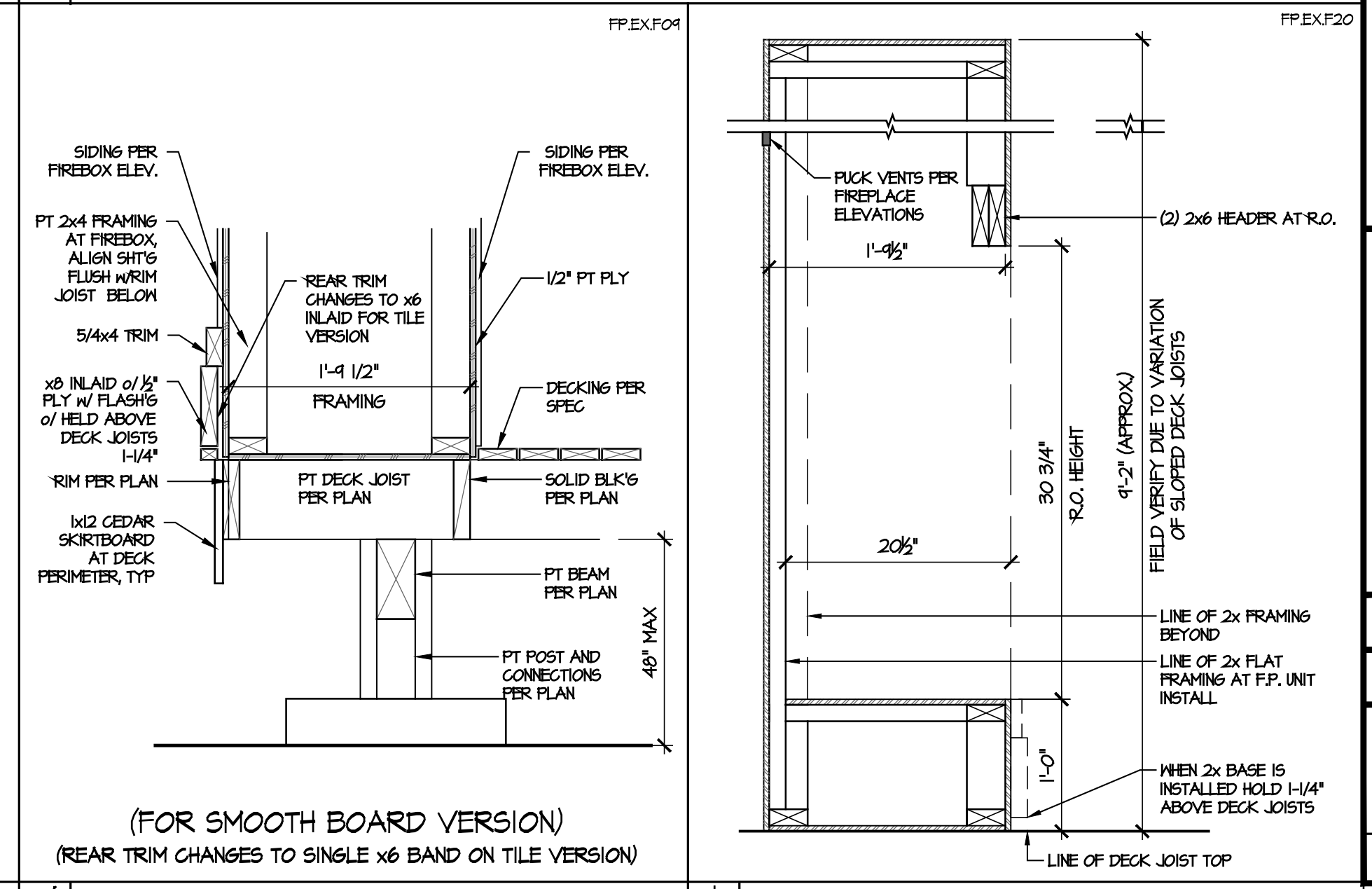

4 PERPENDICULAR FIREBOX DECK FRAMING 1" 1 FIRE BOX ROUGH FRAMING - FULL HT. SECTION 1"

APPROVED  
Plans Reviewed by SAFEbuilt LLC  
For Building Code Compliance  
Reviewed By:  
Bobby Thomas CBO, Plans Examiner,  
Combination Inspector  
Date:  
7/20/2023 REV 1

DESCRIPTION	
NO.	DATE
1	4/20/21
2	5/24/21
3	6/26/21
4	9/12/21

DESCRIPTION	
1	UPDATE DETAILS AND DETAIL SHEET - 05
2	UPDATE DETAILS - 1K
3	UPDATE DETAILS - 1D
4	UPDATE FIREBOX HEIGHT - 1D

121 3rd Ave  
Kirkland, WA 98033  
Phone: (425) 846-4022  
Fax: (425) 846-4024

**MAINVUE**  
WA, LLC

OUTDOOR ROOM OPT. FIREPLACE  
FULL-HEIGHT VERSIONS

DESIGN: SU DRAWN: TD

PLAN No: ...

**SHEET**  
**D3.2**





# GENERAL STRUCTURAL NOTES

THE FOLLOWING APPLY UNLESS SHOWN OTHERWISE ON THE DRAWINGS

## CRITERIA

1. ALL MATERIALS, WORKMANSHIP, DESIGN, AND CONSTRUCTION SHALL CONFORM TO THE DRAWINGS, SPECIFICATIONS, AND THE INTERNATIONAL BUILDING CODE (IBC) (2018 EDITION).

2. DESIGN LOADING CRITERIA

FLOOR LIVE LOAD (RESIDENTIAL)	40 PSF
DECK LIVE LOAD	60 PSF
SNOW	25 PSF
WIND	METHOD - DIRECTIONAL PROCEDURE
	Kz=1.0, Gcpi=0.18, 110 MPH (RISK CATEGORY II), EXPOSURE "B"
EARTHQUAKE	ANALYSIS PROCEDURE: EQUIVALENT LATERAL FORCE PROCEDURE
	LATERAL SYSTEM: LIGHT FRAMED SHEAR WALLS
	SDC D, Ie=1.0, Ss=1.60, S1=0.50, Sds=1.067, Sd1=0.50,
	Cs=0.164, R=6.5,
	SEISMIC DESIGN BASE SHEAR V <sub>sk</sub> =18.8 KIPS

3. STRUCTURAL DRAWINGS SHALL BE USED IN CONJUNCTION WITH ARCHITECTURAL DRAWINGS FOR BIDDING AND CONSTRUCTION. CONTRACTOR SHALL VERIFY DIMENSIONS AND CONDITIONS FOR COMPATIBILITY AND SHALL NOTIFY ARCHITECT OF ANY DISCREPANCIES PRIOR TO CONSTRUCTION.

4. PRIMARY STRUCTURAL ELEMENTS NOT DIMENSIONED ON THE STRUCTURAL PLANS AND DETAILS SHALL BE LOCATED BY THE ARCHITECTURAL PLANS AND DETAILS. VERTICAL DIMENSION CONTROL IS DEFINED BY THE ARCHITECTURAL WALL SECTIONS, BUILDING SECTIONS, AND PLANS. DETAILING AND SHOP DRAWING PRODUCTION FOR STRUCTURAL ELEMENTS WILL REQUIRE DIMENSIONAL INFORMATION CONTAINED IN BOTH ARCHITECTURAL AND STRUCTURAL DRAWINGS.

5. CONTRACTOR SHALL PROVIDE TEMPORARY BRACING FOR THE STRUCTURE AND STRUCTURAL COMPONENTS UNTIL ALL FINAL CONNECTIONS HAVE BEEN COMPLETED IN ACCORDANCE WITH THE PLANS. CONFORM TO ASCE 37-02 "DESIGN LOADS ON STRUCTURES DURING CONSTRUCTION."

6. CONTRACTOR SHALL BE RESPONSIBLE FOR ALL SAFETY PRECAUTIONS AND THE METHODS, TECHNIQUES, SEQUENCES OR PROCEDURES REQUIRED TO PERFORM THE CONTRACTORS WORK. THE STRUCTURAL ENGINEER HAS NO OVERALL SUPERVISORY AUTHORITY OR ACTUAL AND/OR DIRECT RESPONSIBILITY FOR THE SPECIFIC WORKING CONDITIONS AT THE SITE AND/OR FOR ANY HAZARDS RESULTING FROM THE ACTIONS OF ANY TRADE CONTRACTOR. THE STRUCTURAL ENGINEER HAS NO DUTY TO INSPECT, SUPERVISE, NOTE, CORRECT, OR REPORT ANY HEALTH OR SAFETY DEFICIENCIES TO THE OWNER, CONTRACTORS, OR OTHER ENTITIES OR PERSONS AT THE PROJECT SITE.

7. CONTRACTOR-INITIATED CHANGES SHALL BE SUBMITTED IN WRITING TO THE ARCHITECT AND STRUCTURAL ENGINEER FOR APPROVAL PRIOR TO FABRICATION OR CONSTRUCTION. CHANGES SHOWN ON SHOP DRAWINGS ONLY WILL NOT SATISFY THIS REQUIREMENT.

8. DRAWINGS INDICATE GENERAL AND TYPICAL DETAILS OF CONSTRUCTION. WHERE CONDITIONS ARE NOT SPECIFICALLY INDICATED BUT ARE OF SIMILAR CHARACTER TO DETAILS SHOWN, SIMILAR DETAILS OF CONSTRUCTION SHALL BE USED, SUBJECT TO REVIEW AND APPROVAL BY THE ARCHITECT AND THE STRUCTURAL ENGINEER.

9. ALL STRUCTURAL SYSTEMS WHICH ARE TO BE COMPOSED OF COMPONENTS TO BE FIELD ERRECTED SHALL BE SUPERVISED BY THE SUPPLIER DURING MANUFACTURING, DELIVERY, HANDLING, STORAGE, AND ERECTION IN ACCORDANCE WITH INSTRUCTIONS PREPARED BY THE SUPPLIER. MANUFACTURERS INSTALLATION INSTRUCTIONS SHALL BE AVAILABLE ON THE JOB SITE AT THE TIME OF INSPECTION FOR THE INSPECTORS USE AND REFERENCE.

## GEOTECHNICAL

10. ALLOWABLE SOIL PRESSURE AND LATERAL EARTH PRESSURE ARE ASSUMED AND THEREFORE MUST BE VERIFIED BY A QUALIFIED SOILS ENGINEER OR APPROVED BY THE BUILDING OFFICIAL. FOUNDATION DESIGN IS BASED ON THE ASSUMED DESIGN VALUES LISTED BELOW. WHERE APPLICABLE, REFER TO SOILS REPORT IF ASSUMED DESIGN VALUES ARE GREATER THAN THE TYPICAL ASSUMED VALUES OF THE LOCAL JURISDICTION. IF SOILS ARE FOUND TO BE OTHER THAN ASSUMED OR GIVEN IN THE SOILS REPORT, NOTIFY THE STRUCTURAL ENGINEER FOR POSSIBLE FOUNDATION REDESIGN.

FOOTINGS SHALL BEAR ON FIRM, UNDISTURBED EARTH AT LEAST 18" BELOW ADJACENT FINISHED GRADE. FOOTINGS SHALL BE CENTERED BELOW COLUMNS OR WALLS ABOVE. UNO.

BACKFILL BEHIND ALL RETAINING WALLS WITH FREE DRAINING, GRANULAR FILL AND PROVIDE FOR SUBSURFACE DRAINAGE. REFER TO SOILS REPORT, WHERE APPLICABLE.

ALLOWABLE SOIL PRESSURE	2000 PSF
LATERAL EARTH PRESSURE (RESTRAINED/UNRESTRAINED)	50 PCF/35 PCF
COEFFICIENT OF FRICTION	0.35

## CONCRETE

11. CONCRETE SHALL BE MIXED, PROPORTIONED, CONVEYED AND PLACED IN ACCORDANCE WITH ACI 318 AND ACI 301. INCLUDING TESTING PROCEDURES. CONCRETE SHALL ATTAIN A 28-DAY STRENGTH OF F<sub>c</sub> = 3000 PSI. SLUMP OF CONCRETE SHALL NOT EXCEED 6". STRUCTURAL DESIGN IS BASED ON A CONCRETE STRENGTH OF F<sub>c</sub> = 2500 PSI, THEREFORE NO CONCRETE STRENGTH TESTING REQUIRED.

ALL CONCRETE WITH SURFACES EXPOSED TO STANDING WATER SHALL BE AIR-ENTRAINED WITH AN AIR-ENTRAINING AGENT CONFORMING TO ASTM C260, C494, AND C618. TOTAL AIR CONTENT FOR FROST-RESISTANT CONCRETE SHALL BE IN ACCORDANCE WITH ACI 318-14, TABLE 19.3.3.1.

12. REINFORCING STEEL SHALL CONFORM TO ASTM A615 (INCLUDING SUPPLEMENT S1). GRADE 60, F<sub>y</sub> = 60 KSI. EXCEPTIONS: ANY BARS SPECIFICALLY SO NOTED ON THE DRAWINGS SHALL BE GRADE 40, F<sub>y</sub> = 40 KSI. WELDED WIRE FABRIC SHALL CONFORM TO ASTM A1064. SPIRAL REINFORCEMENT SHALL BE DEFORMED WIRE CONFORMING TO ASTM A615, GRADE 60, F<sub>y</sub> = 60 KSI.

13. DETAILING OF REINFORCING STEEL (INCLUDING HOOKS AND BENDS) SHALL BE IN ACCORDANCE WITH ACI 315-99 AND 318-14. LAP ALL CONTINUOUS REINFORCEMENT #6 AND SMALLER 48 BAR DIAMETERS OR 2'-0" MINIMUM. PROVIDE CORNER BARS AT ALL WALL AND FOOTING INTERSECTIONS. LAP CORNER BARS #5 AND SMALLER 48 BAR DIAMETERS OR 2'-0" MINIMUM. LAPS OF LARGER BARS SHALL BE MADE IN ACCORDANCE WITH ACI 318-14, CLASS B. LAP ADJACENT MATS OF WELDED WIRE FABRIC A MINIMUM OF 8' AT SIDES AND ENDS.

NO BARS PARTIALLY EMBEDDED IN HARDENED CONCRETE SHALL BE FIELD BENT UNLESS SPECIFICALLY SO DETAILED OR APPROVED BY THE STRUCTURAL ENGINEER.

14. CONCRETE PROTECTION (COVER) FOR REINFORCING STEEL SHALL BE AS FOLLOWS:

FOOTINGS AND OTHER UNFORMED SURFACES CAST AGAINST AND PERMANENTLY EXPOSED TO EARTH	3"
FORMED SURFACES EXPOSED TO EARTH OR WEATHER (#6 BARS OR LARGER)	2"
FORMED SURFACES EXPOSED TO EARTH OR WEATHER (#5 BARS OR SMALLER)	1-1/2"
COLUMN TIES OR SPIRALS AND BEAM STIRRUPS	1-1/2"
SLABS AND WALLS (INT FACE)	GREATER OF BAR DIAMETER PLUS 1/8" OR 3/4"

## ANCHORAGE

15. EPOXY-GROUTED ITEMS (THREADED RODS OR REINFORCING BAR) SPECIFIED ON THE DRAWINGS SHALL BE INSTALLED USING "SET-XP" EPOXY ADHESIVE AS MANUFACTURED BY THE SIMPSON STRONG TIE COMPANY. INSTALL IN STRICT ACCORDANCE WITH ICC-ES REPORT ESR-2508. SUBSTITUTIONS PROPOSED BY THE CONTRACTOR SHALL BE SUBMITTED FOR REVIEW WITH CURRENT ICC REPORTS INDICATING EQUIVALENT OR GREATER LOAD CAPACITIES. SPECIAL INSPECTION OF INSTALLATION IS REQUIRED. RODS SHALL BE ASTM A36, UNO.

16. HEAVY DUTY THREADED CONCRETE ANCHORS SPECIFIED ON THE DRAWINGS SHALL BE "TITEN HD SCREW ANCHOR" AS MANUFACTURED BY THE SIMPSON STRONG TIE COMPANY. INSTALL IN STRICT ACCORDANCE WITH ICC-ES REPORT ESR-2713, INCLUDING MINIMUM EMBEDMENT AND EDGE DISTANCE REQUIREMENTS. SUBSTITUTIONS PROPOSED BY THE CONTRACTOR SHALL BE SUBMITTED FOR REVIEW WITH ICC REPORTS INDICATING EQUIVALENT OR GREATER LOAD CAPACITIES.

17. EXPANSION BOLTS INTO CONCRETE AND CONCRETE MASONRY UNITS SHALL BE "STRONG-BOLT 2" ANCHORS AS MANUFACTURED BY THE SIMPSON STRONG TIE COMPANY. INSTALL IN STRICT CONFORMANCE TO ICC-ES REPORT ESR-3037, INCLUDING MINIMUM EMBEDMENT AND EDGE DISTANCE REQUIREMENTS. SUBSTITUTIONS PROPOSED BY THE CONTRACTOR SHALL BE SUBMITTED FOR REVIEW WITH CURRENT ICC REPORTS INDICATING EQUIVALENT OR GREATER LOAD CAPACITIES. BOLTS INTO CONCRETE MASONRY OR BRICK MASONRY UNITS SHALL BE INTO FULLY GROUTED CELLS. SPECIAL INSPECTION OF INSTALLATION IS REQUIRED.

## WOOD

18. ALL 2x LUMBER SHALL BE KILN DRIED OR MC-19, AND ALL LUMBER SHALL BE GRADED AND MARKED IN CONFORMANCE WITH WCLIB STANDARD GRADING RULES FOR WEST COAST LUMBER NO 17. FURNISH TO THE FOLLOWING MINIMUM STANDARDS:

JOISTS AND BEAMS	(2x, 3x AND 4x MEMBERS)	HEM-FIR NO 2 OR SPRUCE-PINE-FIR NO 2 MINIMUM BASE VALUE, F <sub>b</sub> = 850 PSI
BEAMS	(6x AND LARGER)	DOUGLAS FIR-LARCH NO 2 MINIMUM BASE VALUE, F <sub>b</sub> = 875 PSI
POSTS	(4x MEMBERS)	HEM-FIR NO 2 OR SPRUCE-PINE-FIR NO 2 MINIMUM BASE VALUE, F <sub>c</sub> = 1100 PSI
	(6x AND LARGER)	DOUGLAS FIR-LARCH NO 2 OR HEM-FIR NO 2 MINIMUM BASE VALUE, F <sub>c</sub> = 575 PSI
STUDS		HEM-FIR STUD GRADE OR SPRUCE-PINE-FIR STUD GRADE MINIMUM BASE VALUE, F <sub>c</sub> = 725 PSI
PLATES AND MISC FRAMING		HEM-FIR NO 2 OR SPRUCE-PINE-FIR NO 2

19. GLUED LAMINATED MEMBERS SHALL BE FABRICATED IN CONFORMANCE WITH ASTM AND ANSI/AITC STANDARDS. EACH MEMBER SHALL BEAR AN AITC OR APA-EWS IDENTIFICATION MARK AND SHALL BE ACCOMPANIED BY AN AITC OR APA-EWS CERTIFICATE OF CONFORMANCE. ALL GLULAM BEAMS SHALL BE DOUGLAS FIR COMBINATION 24F-V4, F<sub>b</sub> = 2400 PSI, F<sub>v</sub> = 265 PSI, E = 1800 KSI, UNO. ALL 24F-V8 GLULAM BEAMS WILL BE SPECIFIED ON PLAN AND SHALL BE DOUGLAS FIR COMBINATION 24F-V8, F<sub>b</sub> = 2400 PSI, F<sub>v</sub> = 265 PSI, E = 1800 KSI. GLUED LAMINATED COLUMNS SHALL BE DOUGLAS FIR COMBINATION 3, L2D GRADE, F<sub>c</sub> = 2300 PSI, F<sub>b</sub> = 2000 PSI, E = 1900 KSI.

20. MANUFACTURED LUMBER, PSL, LVL, AND LSL, SHALL BE MANUFACTURED UNDER A PROCESS APPROVED BY THE NATIONAL RESEARCH BOARD. EACH PIECE SHALL BEAR A STAMP OR STAMPS NOTING THE NAME AND PLANT NUMBER OF THE MANUFACTURER, THE GRADE, THE NATIONAL RESEARCH BOARD NUMBER, AND THE QUALITY CONTROL AGENCY. ALL PSL, LVL, AND LSL LUMBER SHALL BE MANUFACTURED IN ACCORDANCE WITH ICC-ES REPORT ESR-1387 USING DOUGLAS FIR VENEER GLUED WITH A WATERPROOF ADHESIVE MEETING THE REQUIREMENTS OF ASTM D2559 WITH ALL GRAIN PARALLEL WITH THE LENGTH OF THE MEMBER. THE MEMBERS SHALL HAVE THE FOLLOWING MINIMUM PROPERTIES:

PSL (2.0E)	F <sub>b</sub> = 2900 PSI	E = 2000 KSI	F <sub>v</sub> = 290 PSI
LVL (2.0E)	F <sub>b</sub> = 2600 PSI	E = 2000 KSI	F <sub>v</sub> = 285 PSI
LSL (1.55E)	F <sub>b</sub> = 2325 PSI	E = 1550 KSI	F <sub>v</sub> = 310 PSI
PSL COLUMN (1.8E)	F <sub>c</sub> = 2500 PSI	E = 1800 KSI	F <sub>v</sub> = 190 PSI

DESIGN SHOWN ON PLANS IS BASED ON LUMBER MANUFACTURED BY THE TRUS-JOIST CORPORATION. ALTERNATE MANUFACTURERS MAY BE USED SUBJECT TO REVIEW AND APPROVAL BY THE ARCHITECT AND STRUCTURAL ENGINEER. ALTERNATE JOIST HANGERS AND OTHER HARDWARE MAY BE SUBSTITUTED FOR ITEMS SHOWN PROVIDED THEY HAVE CURRENT ICC APPROVAL FOR EQUAL OR GREATER LOAD CAPACITIES. ALL JOIST HANGERS AND OTHER HARDWARE SHALL BE COMPATIBLE IN SIZE WITH MEMBERS PROVIDED.

MANUFACTURED LUMBER PRODUCTS SHALL BE INSTALLED WITH A MOISTURE CONTENT OF 12% OR LESS. THE CONTRACTOR SHALL MAKE PROVISIONS DURING CONSTRUCTION TO PREVENT THE MOISTURE CONTENT OF INSTALLED BEAMS FROM EXCEEDING 12%. EXCESSIVE DEFLECTIONS MAY OCCUR IF MOISTURE CONTENT EXCEEDS THIS VALUE.

21. PREFABRICATED CONNECTOR PLATE WOOD FLOOR TRUSSES SHALL BE DESIGNED BY THE MANUFACTURER IN ACCORDANCE WITH THE "NATIONAL DESIGN STANDARD FOR METAL PLATE-CONNECTED WOOD TRUSS CONSTRUCTION", ANSI/TPI 1 BY THE TRUSS PLATE INSTITUTE FOR THE SPANS AND CONDITIONS SHOWN ON THE PLANS. LOADING SHALL BE AS FOLLOWS:

TOP CHORD LIVE LOAD	40 PSF
TOP CHORD DEAD LOAD	10 PSF
BOTTOM CHORD DEAD LOAD	5 PSF
TOTAL LOAD	55 PSF

REFER TO PLAN FOR ADDITIONAL LOADING. ALL FLOOR TRUSSES SHALL BE DESIGNED FOR A MAXIMUM LIVE LOAD DEFLECTION OF THE SPAN DIVIDED BY 480.

WOOD TRUSSES SHALL UTILIZE APPROVED CONNECTOR PLATES (GANGNAIL OR EQUAL). SUBMIT SHOP DRAWINGS AND DESIGN CALCULATIONS TO THE ARCHITECT AND STRUCTURAL ENGINEER FOR REVIEW PRIOR TO FABRICATION. SUBMITTED DOCUMENTS SHALL BE STAMPED AND SIGNED BY A STRUCTURAL ENGINEER REGISTERED IN THE STATE OF WASHINGTON. PROVIDE FOR SHAPE BEARING POINTS, INTERSECTIONS, ETC. SHOWN ON THE DRAWINGS. PROVIDE ALL TRUSS TO TRUSS AND TRUSS TO GIRDER TRUSS CONNECTION DETAILS AND REQUIRED CONNECTION MATERIALS. PROVIDE FOR ALL TEMPORARY AND PERMANENT TRUSS BRACING AND BRIDGING.

22. PREFABRICATED CONNECTOR PLATE WOOD ROOF TRUSSES SHALL BE DESIGNED BY THE MANUFACTURER IN ACCORDANCE WITH THE "NATIONAL DESIGN STANDARD FOR METAL PLATE-CONNECTED WOOD TRUSS CONSTRUCTION, ANSI/TPI 1" BY THE TRUSS PLATE INSTITUTE FOR THE SPANS AND CONDITIONS SHOWN ON THE PLANS. LOADING SHALL BE AS FOLLOWS:

TOP CHORD LIVE LOAD	25 PSF
TOP CHORD DEAD LOAD	8 PSF
BOTTOM CHORD DEAD LOAD	7 PSF
TOTAL LOAD	40 PSF

WIND UPLIFT (TOP CHORD)	10 PSF
BOTTOM CHORD LIVE LOAD (BOTTOM CHORD LIVE LOAD DOES NOT ACT CONCURRENTLY WITH THE ROOF LIVE LOAD)	10 PSF

TRUSSES SHALL BE DESIGNED TO NOT ALLOW LIMITED STORAGE PER IBC TABLE 1607.1. WEBS SHALL BE CONFIGURED SO THAT ALL OPENINGS ARE SMALLER THAN 24" WIDE x 42" HIGH.

TRUSSES SHALL BEAR AT EXTERIOR WALLS ONLY UNLESS SPECIFICALLY NOTED ON PLANS.

WOOD TRUSSES SHALL UTILIZE APPROVED CONNECTOR PLATES (GANGNAIL OR EQUAL). SUBMIT SHOP DRAWINGS AND DESIGN CALCULATIONS TO THE ARCHITECT AND STRUCTURAL ENGINEER FOR REVIEW PRIOR TO FABRICATION. SUBMITTED DOCUMENTS SHALL BE SIGNED AND STAMPED BY A PROFESSIONAL ENGINEER REGISTERED IN THE STATE OF WASHINGTON. PROVIDE FOR SHAPES, BEARING POINTS, INTERSECTIONS, HIPS, VALLEYS, ETC. SHOWN ON THE DRAWINGS. EXACT COMPOSITION OF SPECIAL HIP, VALLEY, AND INTERSECTION AREAS, USE OF GIRDER TRUSSES, JACK TRUSSES, STEP-DOWN TRUSSES, ROOF OVER-FRAMING, ETC SHALL BE DETERMINED BY THE MANUFACTURER UNLESS SPECIFICALLY INDICATED ON THE PLANS. PROVIDE ALL TRUSS TO TRUSS AND TRUSS TO GIRDER TRUSS CONNECTION DETAILS AND REQUIRED CONNECTION MATERIALS. PROVIDE FOR ALL TEMPORARY AND PERMANENT TRUSS BRACING AND BRIDGING PER IRC SECTION R802.10.3 AND THE TRUSS PLATE INSTITUTES BUILDING COMPONENT SAFETY INFORMATION. MANUFACTURERS INSTALLATION INSTRUCTIONS SHALL BE AVAILABLE ON THE JOB SITE AT THE TIME OF INSPECTION PER IRC SECTION 106.1.2. TRUSS ALTERATIONS SHALL NOT OCCUR WITHOUT THE APPROVAL OF A DESIGN PROFESSIONAL AS INDICATED IN IRC SECTION 802.10.4.

23. PLYWOOD SHEATHING SHALL BE GRADE C-D, EXTERIOR GLUE OR STRUCTURAL II, EXTERIOR GLUE IN CONFORMANCE WITH DOC PS-1 OR PS-2. ORIENTED STRAND BOARD OF EQUIVALENT THICKNESS, EXPOSURE RATING AND PANEL INDEX MAY BE USED IN LIEU OF PLYWOOD.

WALL SHEATHING SHALL BE 7/16" or 1/2" (NOMINAL) WITH SPAN RATING 24/0

FLOOR SHEATHING SHALL BE 3/4" T&G (NOMINAL) WITH SPAN RATING 48/24

ROOF SHEATHING SHALL BE 1/2" or 7/16" (NOMINAL) WITH SPAN RATING 32/16

REFER TO WOOD FRAMING NOTES BELOW FOR TYPICAL NAILING REQUIREMENTS.

24. ALL WOOD IN DIRECT CONTACT WITH CONCRETE OR MASONRY SHALL BE PRESSURE-TREATED WITH AN APPROVED PRESERVATIVE OR (2) LAYERS OF ASPHALT IMPREGNATED BUILDING PAPER SHALL BE PROVIDED BETWEEN UNTREATED WOOD AND CONCRETE OR MASONRY.

25. PRESSURE TREATED WOOD (INCLUDES PRESERVATIVE AND FIRE TREATED) SHALL BE TREATED PER AWP A STANDARDS U1 AND M4. PRESSURE TREATED WOOD FOR ABOVE GROUND USE SHALL BE TREATED TO RETENTION OF 0.25 PCF. WOOD IN CONTINUOUS CONTACT WITH FRESH WATER OR SOIL SHALL BE TREATED TO A RETENTION OF 0.40 PCF. SODIUM BORATE (SBX) TREATED WOOD SHALL NOT BE USED WHERE EXPOSED TO WEATHER. FASTENERS AND TIMBER CONNECTORS WITHOUT AMMONIA IN DIRECT CONTACT WITH ACQ-A TO A RETENTION LEVEL OF 0.40 PCF). CBA-A (UP TO A RETENTION LEVEL OF 0.41 PCF). CBA-B (UP TO A RETENTION LEVEL OF 0.21 PCF). SHALL BE G185 OR A185 HOT DIPPED OR CONTINUOUS HOT-GALVANIZED PER ASTM A653. FASTENERS AND TIMBER CONNECTORS WITH AMMONIA IN DIRECT CONTACT WITH ACQ-A (OVER A RETENTION LEVEL OF 0.40 PCF). CBA-A (OVER A RETENTION LEVEL OF 0.41 PCF). C-A-B (OVER A RETENTION LEVEL OF 0.21 PCF). OR WITH ACZA TREATED WOOD SHALL BE TYPE 304 OR 316 STAINLESS STEEL.

26. TIMBER CONNECTORS CALLED OUT BY LETTERS AND NUMBERS SHALL BE "USP" STRUCTURAL CONNECTORS. AS SPECIFIED IN THEIR 60TH EDITION PRODUCT CATALOG. EQUIVALENT DEVICES BY OTHER MANUFACTURERS MAY BE SUBSTITUTED, PROVIDED THEY HAVE CURRENT ICC APPROVAL FOR EQUAL OR GREATER LOAD CAPACITIES. PROVIDE NUMBER AND SIZE OF FASTENERS AS SPECIFIED BY MANUFACTURER. CONNECTORS SHALL BE INSTALLED IN ACCORDANCE WITH THE MANUFACTURER'S RECOMMENDATIONS.

ALL 2x JOISTS SHALL BE CONNECTED TO FLUSH BEAMS WITH "JUS" OR "JL" SERIES JOIST HANGERS. ALL I-JOISTS SHALL BE CONNECTED TO FLUSH BEAMS WITH "THF" OR "TH" SERIES JOIST HANGERS.

WHERE CONNECTOR STRAPS CONNECT TWO MEMBERS, PLACE ONE-HALF OF THE NAILS OR BOLTS IN EACH MEMBER.

ALL SHIMS SHALL BE SEASONED AND DRIED AND THE SAME GRADE (MINIMUM) AS MEMBERS CONNECTED.

## 27. WOOD FASTENERS

A. NAIL SIZES SPECIFIED ON DRAWINGS ARE BASED ON THE FOLLOWING SPECIFICATIONS:

SIZE	TYPE	LENGTH	DIAMETER
8d	COMMON	2-1/2"	0.131"
10d	GUN	3"	0.131"
12d	GUN	3-1/4"	0.131"

IF CONTRACTOR PROPOSES THE USE OF ALTERNATE NAILS, THEY SHALL SUBMIT NAIL SPECIFICATIONS TO THE STRUCTURAL ENGINEER (PRIOR TO CONSTRUCTION) FOR REVIEW AND APPROVAL.

NAILS - PLYWOOD (APA RATED SHEATHING) FASTENERS TO FRAMING SHALL BE DRIVEN FLUSH TO FACE OF SHEATHING WITH NO COUNTERSINKING PERMITTED.

B. ALL BOLTS IN WOOD MEMBERS SHALL CONFORM TO ASTM A307. PROVIDE WASHERS UNDER THE HEADS AND NUTS OF ALL BOLTS AND LAG BOLTS BEARING ON WOOD. INSTALLATION OF LAG SCREWS SHALL CONFORM TO THE NATIONAL DESIGN SPECIFICATION FOR WOOD CONSTRUCTION (2018 EDITION) WITH A LEAD BORE HOLE OF 60-70% OF THE SHANK DIAMETER. LEAD HOLES ARE NOT REQUIRED FOR 3/8" AND SMALLER LAG SCREWS. BOLT HOLES SHALL BE A MINIMUM OF 1/32" TO A MAXIMUM OF 1/16" LARGER THAN THE BOLT DIAMETER. HOLES SHALL BE ACCURATELY ALIGNED IN MAIN MEMBERS' AND SIDE PLATES/ MEMBERS. BOLTS SHALL NOT BE FORCIBLY DRIVEN.

C. TIMBERLOK AND LEDGERLOK FASTENERS CALLED OUT BY LETTERS AND NUMBERS SHALL BE FASTEN-MASTER STRUCTURAL WOOD SCREWS MANUFACTURED AND INSTALLED IN STRICT ACCORDANCE WITH ICC-ES REPORT ESR-1078. WS SERIES WOOD SCREWS CALLED OUT ON PLAN SHALL BE "USP" WOOD SCREWS, AND INSTALLED IN STRICT ACCORDANCE WITH ICC-ES REPORT ESR-2761 PER THE "USP" STRUCTURAL CONNECTORS CATALOG ABOVE. EQUIVALENT SCREWS BY OTHER MANUFACTURERS MAY BE SUBSTITUTED, PROVIDED THEY HAVE ICC-ES APPROVAL FOR EQUAL OR GREATER LOAD CAPACITIES. LAG SCREWS ARE NOT AN EQUIVALENT SUBSTITUTION.

## 28. WOOD FRAMING NOTES - THE FOLLOWING APPLY UNLESS NOTED OTHERWISE ON THE PLANS:

A. ALL WOOD FRAMING DETAILS NOT SHOWN OTHERWISE SHALL BE CONSTRUCTED TO THE MINIMUM STANDARDS OF THE IBC, THE AITC "TIMBER CONSTRUCTION MANUAL", AND THE AF&PA "NATIONAL DESIGN SPECIFICATION FOR WOOD CONSTRUCTION". MINIMUM NAILING, SHALL CONFORM TO TABLE 2304.10.1. OF THE IBC, UNO. COORDINATE THE SIZE AND LOCATION OF ALL OPENINGS WITH ARCHITECTURAL AND MECHANICAL DRAWINGS.

B. WALL FRAMING: REFER TO ARCHITECTURAL DRAWINGS FOR THE SIZE OF ALL WALLS. ALL STUDS SHALL BE SPACED AT 16"oc, UNO. (2)STUDS MINIMUM SHALL BE PROVIDED AT THE END OF ALL WALLS AND AT EACH SIDE OF ALL OPENINGS, AND AT BEAM OR HEADER BEARING LOCATIONS. (2)2x8 HEADERS SHALL BE PROVIDED OVER ALL OPENINGS IN STRUCTURAL WALLS, UNO. NAIL MULTI-MEMBER HEADERS WITH (2)ROWS 10d AT 12"oc. SOLID BLOCKING FOR WOOD COLUMNS SHALL BE PROVIDED THROUGH FLOORS TO SUPPORTS BELOW. PROVIDE CONTINUOUS SOLID AT MID-HEIGHT OF ALL STUD WALLS OVER 10'-0" IN HEIGHT.

ALL WALLS SHALL HAVE A SINGLE BOTTOM PLATE AND A DOUBLE TOP PLATE. END NAIL TOP PLATE AND BOTTOM PLATE TO EACH STUD WITH (3) 10d NAILS. FACE NAIL DOUBLE TOP PLATES WITH 10d AT 12"oc AND LAP MINIMUM 4'-0" AT JOINTS AND PROVIDE (12) 10d NAILS AT 4"oc EACH SIDE OF JOINT. AT TOP PLATE INTERSECTIONS PROVIDE (3) 10d FACE NAILS.

ALL STUD WALLS SHALL HAVE THEIR LOWER WOOD PLATES ATTACHED TO WOOD FRAMING BELOW WITH (2)ROWS OF 12d NAILS AT 16"oc, OR ATTACHED TO CONCRETE BELOW WITH 5/8" DIAMETER ANCHOR BOLTS AT 4'-0"oc EMBEDDED 7" MINIMUM, UNO. THERE SHALL BE A MINIMUM OF (2)BOLTS PER PLATE SECTION WITH (1)BOLT LOCATED NOT MORE THAN 1/2' OR LESS THAN 4-1/2" FROM EACH END OF THE PLATE SECTION. INDIVIDUAL MEMBERS OF BUILT-UP POSTS SHALL BE NAILED TO EACH OTHER WITH (2)ROWS OF 10d AT 16"oc. UNLESS NOTED OTHERWISE, GYPSUM WALLBOARD SHALL BE FASTENED TO THE INTERIOR SURFACE OF ALL STUDS AND PLATES WITH #6 x 1-1/4" TYPE S OR W SCREWS AT 12"oc. UNLESS NOTED OTHERWISE, 7/16" OR 1/2" (NOMINAL) APA RATED SHEATHING (SPAN RATING 24/0) SHALL BE NAILED TO ALL EXTERIOR SURFACES WITH 8d NAILS AT 6"oc AT PANEL EDGES AND TOP AND BOTTOM PLATES (BLOCK UN-SUPPORTED EDGES) AND TO ALL INTERMEDIATE STUDS AND BLOCKING WITH 8d NAILS AT 12"oc. ALLOW 1/8" SPACING AT ALL PANEL EDGES AND PANEL ENDS.

C. FLOOR AND ROOF FRAMING: PROVIDE DOUBLE JOISTS UNDER ALL PARALLEL PARTITIONS THAT EXTEND OVER MORE THAN HALF THE JOIST LENGTH AND AROUND ALL OPENINGS IN FLOORS OR ROOFS, UNO. PROVIDE SOLID BLOCKING AT ALL BEARING POINTS. TOENAIL TIMBER JOISTS TO SUPPORTS WITH (3) 10d NAILS AND NAIL TJI JOISTS TO SUPPORTS WITH (2) 10d NAILS. ATTACH JOISTS TO BEAMS WITH SIMPSON JOIST HANGERS IN ACCORDANCE WITH NOTES ABOVE. NAIL ALL MULTI-JOIST BEAMS TOGETHER WITH (2)ROWS 10d AT 12"oc. TOENAIL RIM JOIST TO TOP PLATE WITH 10d AT 6"oc. TOENAIL BLOCKING BETWEEN JOISTS TO TOP PLATE WITH (3) 10d NAILS.

UNLESS NOTED OTHERWISE ON THE PLANS, PLYWOOD ROOF AND FLOOR SHEATHING SHALL BE LAID UP WITH GRAIN PERPENDICULAR TO SUPPORTS WITH END JOINTS STAGGERED, AND NAILED AT 6"oc WITH 8d NAILS TO FRAMED PANEL EDGES. STRUTS AND OVER STUD WALLS AS SHOWN ON PLANS AND AT 12"oc TO INTERMEDIATE SUPPORTS. PROVIDE APPROVED PLYWOOD EDGE CLIPS CENTERED BETWEEN JOISTS/TRUSSES AT UNBLOCKED ROOF SHEATHING EDGES. ALL FLOOR SHEATHING EDGES SHALL HAVE APPROVED T&G JOINTS OR SHALL BE SUPPORTED WITH SOLID BLOCKING. ALLOW 1/8" SPACING AT ALL PANEL EDGES AND ENDS OF FLOOR AND ROOF SHEATHING. TOENAIL BLOCKING TO SUPPORTS WITH 10d AT 12"oc, UNO.

## 29. NOTCHES AND HOLES IN WOOD FRAMING:

A. SAWN LUMBER JOISTS AND RAFTERS: NOTCHES AT THE ENDS OF JOISTS SHALL NOT EXCEED 1/4 THE JOIST DEPTH. NOTCHES IN THE TOP OR BOTTOM OF JOISTS SHALL NOT EXCEED 1/6 THE JOIST DEPTH, BE LONGER THAN 1/3 THE JOIST DEPTH, OR BE LOCATED IN THE MIDDLE 1/3 OF THE SPAN. HOLES SHALL NOT BE WITHIN 2" OF THE TOP OR BOTTOM OF THE JOIST AND THE DIAMETER SHALL NOT EXCEED 1/3 THE JOIST DEPTH. SPACING BETWEEN HOLES SHALL BE A MINIMUM OF (2)TIMES THE DIAMETER OF THE LARGEST HOLE OR 2" AND SHALL BE LOCATED A MINIMUM OF 2" FROM ANY NOTCH.

B. EXTERIOR END BEARING WALLS: WOOD STUDS ARE PERMITTED TO BE NOTCHED TO A DEPTH NOT EXCEEDING 1/4 OF ITS WIDTH. A HOLE NOT GREATER IN DIAMETER THAN 40% OF THE STUD WIDTH IS PERMITTED IN WOOD STUDS. HOLES SHALL NOT BE WITHIN 5/8" TO THE EDGE OF THE STUD. SPACING BETWEEN HOLES SHALL BE A MINIMUM OF (2)TIMES THE DIAMETER OF THE LARGEST HOLE OR 2" AND SHALL NOT BE LOCATED AT THE SAME SECTION AS A NOTCH.

C. CUTS, NOTCHES, AND HOLES IN MANUFACTURED LUMBER, PREFABRICATED PLYWOOD WEB JOISTS, AND PREFABRICATED TRUSSES ARE PROHIBITED EXCEPT WHERE NOTED ON STRUCTURAL PLANS OR PERMITTED BY MANUFACTURER'S RECOMMENDATIONS.

30. ELECTRICAL, MECHANICAL, PLUMBING, AND DRAINAGE SYSTEMS SHALL BE DESIGNED TO ACCOMMODATE THE DIFFERENTIAL SHRINKAGE OR MOVEMENT OF THE WOOD STRUCTURE (3/8" PER FLOOR).

31. DEFLECTION OF CANTILEVERS SHALL BE CLOSELY MONITORED BY THE CONTRACTOR DURING CONSTRUCTION. CONTRACTOR TO VERIFY AND ENSURE ALL POST CAPS AND POST BEARING CONDITIONS ARE INSTALLED IN STRICT CONFORMANCE TO THE STRUCTURAL PLANS. CANTILEVERS IN WOOD FRAMING CAN DEFLECT UP TO 1/8" PER FOOT (I.E. 4" CANTILEVER MAY DEFLECT 1/2"). IF DEFLECTION EXCEEDS 1/8" PER FOOT NOTIFY STRUCTURAL ENGINEER IMMEDIATELY. BEFORE FINISHES ARE INSTALLED, FLOORS AT OR ABOVE CANTILEVERS MAY REQUIRE LEVELING COMPOUND AND SOFFITS FURRED TO MAKE THEM LEVEL.

## ABBREVIATIONS

±	PLUS OR MINUS	GL	GLUE LAMINATED	OSB	ORIENTED STRAND BOARD
Ø	DIAMETER	GR	GRADE	PLF	POUNDS PER LINEAR FOOT
AB	ANCHOR BOLT	GR	GRADE	PLF	POUNDS PER LINEAR FOOT
ADDL	ADDITIONAL	GT	GIRDER TRUSS		
ALT	ALTERNATE	GWB	GYPSUM WALLBOARD	PLY	PLYWOOD
APPROX	APPROXIMATE	HD	HOLDOWN	PREFAB	PREFABRICATED
ARCH	ARCHITECT, ARCHITECTURAL	HR	HEADER	PSF	POUNDS PER SQUARE FOOT
BLKG	BLOCKING	HGR	HANGER	PSI	POUNDS PER SQUARE INCH
BM	BEAM	HM	HIP MASTER		
BOE	BOTTOM OF EXCAVATION	HORIZ	HORIZONTAL	PSL	PARALLEL STRAND LUMBER
BOT	BOTTOM	HT	HEIGHT		
C	CENTERLINE	IBC	INTERNATIONAL BUILDING CODE	PT	PRESSURE TREATED LUMBER
CLR	CLEARANCE	INT	INTERIOR	REINF	REINFORCING
CONT	CONTINUOUS	IRC	INTERNATIONAL RESIDENTIAL CODE	REQD	REQUIRED
DBL	DOUBLE			SOG	SLAB ON GRADE
DF	DOUGLAS FIR	JST	JOIST	SQ	SQUARE
DP	DEEP. DEPTH	K	KIPS (1000 LBS)	STD	STANDARD
DN	DOWN	KP	KING POST	SW	SHEARWALL
DS	DRAG STRUT	L	LENGTH	T&G	TONGUE AND GROOVE
DWGS	DRAWINGS	LBS	POUNDS	THRD	THREADED
(E)	EXISTING	LONG	LONGITUDINAL	TPL	TRIPLE
EA	EACH	LSL	LAMINATED	TRANSV	TRANSVERSE
EMBED	EMBEDMENT			TYP	TYPICAL
EQ	EQUAL	LVL	LAMINATED VENEER LUMBER	UNO	UNLESS NOTED OTHERWISE
EQUIV	EQUIVALENT				







**APPROVED**  
Plans Reviewed by **SAFEbuilt**  
For Building Code Compliance

Reviewed By:  
**Bobby Thomas** CBO, Plans Examiner,  
Combination Inspector

Date:  
**7/20/2023 REV 1**



PROJECT NO 0135.2020.12.0306  
PROJECT MANAGER RAF  
DRAWN JSD  
ENGINEER NATE MOORE  
206.602.9537  
NATEM@MALSAM-TSANG.COM

REV	DESCRIPTION	DATE
1	PERMIT SET	7.6.23

ARCH MAINVUE HOMES  
425.646.4022

**UPPER FLOOR FRAMING PLAN**

**S2.2**

SCALE - 1/4" = 1'-0"

**FLOOR TRUSS LOADING**

- TRUSS MANUFACTURER TO DESIGN FOR A 1100 LBS POINT LOAD AT WINDOW TRIMMER ABOVE
- NOT USED
- NOT USED
- TRUSS MANUFACTURER TO DESIGN FOR A 440 LBS/FT LINE LOAD AT END OF CANTILEVERED TRUSSES FOR ROOF AND WALL ABOVE AND FOR ROOF LOAD
- TRUSS MANUFACTURER TO DESIGN TRUSS OR LINE OF TRUSS BLKG TO TRANSFER 375 PLF LATERALLY FROM TOP TO BOTTOM CHORD
- TRUSS MANUFACTURER TO DESIGN TRUSS OR LINE OF TRUSS BLKG TO TRANSFER 230 PLF LATERALLY FROM TOP TO BOTTOM CHORD
- TRUSS MANUFACTURER TO DESIGN TRUSS OR LINE OF TRUSS BLKG TO TRANSFER 100 PLF LATERALLY FROM TOP TO BOTTOM CHORD

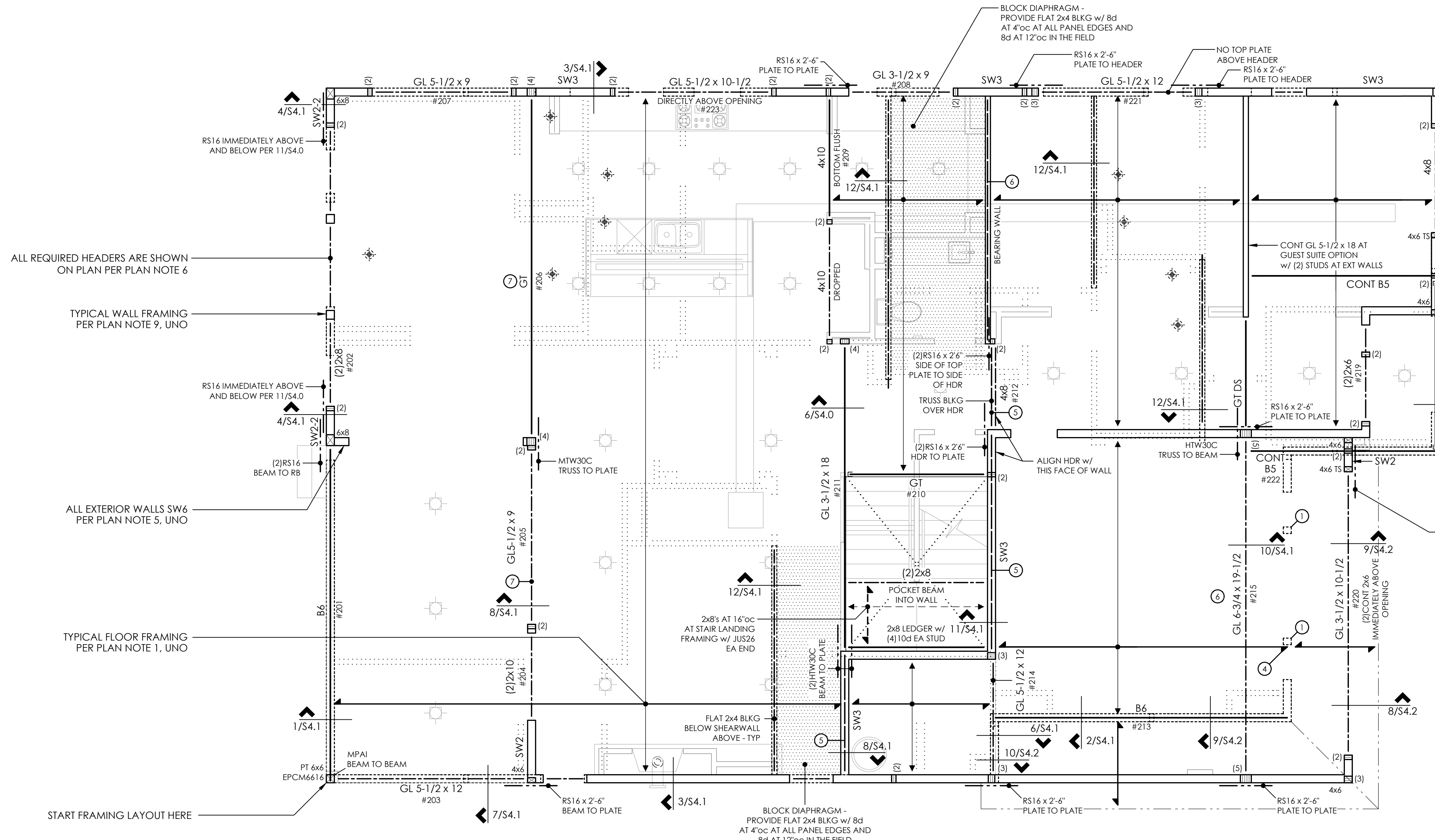

ALL REQUIRED HEADERS ARE SHOWN ON PLAN PER PLAN NOTE 6

TYPICAL WALL FRAMING PER PLAN NOTE 9, UNO

RS16 IMMEDIATELY ABOVE AND BELOW PER 11/S4.0

ALL EXTERIOR WALLS SW6 PER PLAN NOTE 5, UNO

TYPICAL FLOOR FRAMING PER PLAN NOTE 1, UNO

START FRAMING LAYOUT HERE

**PLAN NOTES**

- TYPICAL FLOOR FRAMING CONSISTS OF 3/4" T&G APA RATED SHEATHING (SPAN RATING 48/24) OVER PRE-MANUFACTURED TRUSSES AT 19.2"oc. UNO. TRUSSES TO BE A MIN DEPTH OF 18"
- GLUE AND NAIL FLOOR SHEATHING w/ 8d AT 6"oc AT FRAMED PANEL EDGES AND OVER SHEARWALLS AND AT 12"oc IN FIELD, UNO.
- TYPICAL ROOF FRAMING CONSISTS OF 7/16" or 1/2" APA RATED SHEATHING (SPAN RATING 32/16) OVER PRE-MANUFACTURED TRUSSES AT 24"oc. UNO. PROVIDE TIMBERLOK TLOK06 SCREWS EACH END OF ALL TRUSSES, AND EACH PLY OF ALL MULTIPLE TRUSSES, UNO. REFER TO ARCH DRAWINGS FOR TRUSS PROFILE. TRUSSES SHALL BEAR AT EXTERIOR WALLS ONLY, UNO. ALL OVERFRAMING SHALL BE PER TRUSS MANUFACTURER. GABLE END TRUSSES SHALL BE DESIGNED TO SPAN OPENINGS.
- NAIL ROOF SHEATHING w/ 8d AT 6"oc AT FRAMED PANEL EDGES AND OVER SHEARWALLS, AND AT 12"oc IN THE FIELD, UNO.
- "SW\_" INDICATES SHEARWALL BELOW FRAMING SHOWN. REFER TO SHEARWALL SCHEDULE ON 4/S4.0 FOR ADDITIONAL INFORMATION. ALL EXTERIOR WALLS ARE SW6, UNO.
- ALL REQUIRED HEADERS ARE SHOWN ON PLAN AND SHALL BE (2)2x8, UNO. REFER TO DETAIL 8/S4.0 FOR ADDITIONAL REQUIREMENTS.
- PROVIDE (2)BEARING (TRIMMER) STUDS AT EACH END OF ALL HEADERS, BEAMS, AND GIRDER TRUSSES OVER 6'-0" IN LENGTH, UNO.
- WHERE POSTS OCCUR, PROVIDE SOLID VERTICAL GRAIN BLOCKING THRU FLOOR TO MATCHING SUPPORTS BELOW, UNO.
- TYPICAL WALL FRAMING CONSISTS OF 2x6's AT 16"oc AT EXTERIOR WALLS AND 2x4's or 2x6's AT 16"oc AT INTERIOR WALLS PER ARCH DRAWINGS, UNO.
- PLUMBING DROPS AND RECESSED LIGHTING LOCATIONS PROVIDED BY ARCHITECT AND DIMENSIONS SHALL BE VERIFIED.
- REFER TO SHEET S4.0 FOR TYPICAL WOOD FRAMING DETAILS.
- REFER TO GENERAL STRUCTURAL NOTES SHEET S1.0 FOR ADDITIONAL REQUIREMENTS.
- DO NOT SCALE DRAWINGS. REFER TO ARCH DRAWINGS FOR ALL DIMENSIONS.

**LEGEND**

- STRUCTURAL WALL BELOW
- STRUCTURAL WALL ABOVE
- SPAN AND EXTENTS
- HEADER/BEAM BELOW FRAMING - TYP
- (X) NUMBER OF BUILT UP STUDS
- PLUMBING PENETRATION ABOVE
- KS KING STUD
- TS TRIMMER STUD
- RB RIBBON BOARD
- DS DRAG STRUT - NAIL THRU SHEATHING w/ 8d AT 4'oc INTO ENTIRE LENGTH OF MEMBER
- RECESSED LIGHTING
- BLOCK DIAPHRAGM - PROVIDE FLAT 2x4 BLKG w/ 8d AT 4'oc AT ALL PANEL EDGES AND 8d AT 12'oc IN THE FIELD

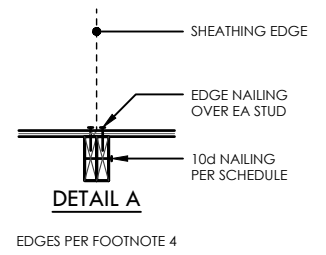

**SHEARWALL SCHEDULE**

MARK	SHEATHING	PANEL EDGE NAILING	TOP PLATE CONNECTION		BASE PLATE CONNECTION	
			I-JOIST	RIM/BEAM	AT WOOD	AT CONCRETE
SW6	1/2" PLY or 7/16" OSB	8d AT 6"oc	10d AT 6"oc	MPA1 AT 30"oc	12d AT 6"oc	5/8" AB AT 48"oc
SW4	1/2" PLY or 7/16" OSB	8d AT 4"oc	10d AT 4"oc	MPA1 AT 18"oc	12d AT 4"oc	5/8" AB AT 42"oc
SW3	1/2" PLY or 7/16" OSB	8d AT 3"oc	(2)ROWS 10d AT 6"oc	MPA1 AT 16"oc	(2)ROWS 12d AT 6"oc	5/8" AB AT 36"oc
SW2	1/2" PLY or 7/16" OSB	8d AT 2"oc	(2)ROWS 10d AT 4"oc	MPA1 AT 12"oc	(2)ROWS 12d AT 4"oc	5/8" AB AT 24"oc
SW3-Q	1/2" PLY or 7/16" OSB EA SIDE	8d AT 3"oc EA SIDE	N/A	MPA1 AT 8"oc	(2)ROWS 12d AT 3"oc	5/8" AB AT 18"oc
SW2-Q	1/2" PLY or 7/16" OSB EA SIDE	8d AT 2"oc EA SIDE	N/A	MPA1 AT 6"oc	(3)ROWS 12d AT 3"oc	5/8" AB AT 12"oc

- BLOCK PANEL EDGES WITH 2x4 LAID FLAT AND NAIL PANELS TO INTERMEDIATE SUPPORTS WITH 8d AT 12"oc.
- 8d NAILS SHALL BE 0.131"Ø x 2-1/2". 10d NAILS SHALL BE 0.131"Ø x 3". AND 12d NAILS SHALL BE 0.131"Ø x 3-1/4".
- EMBED ANCHOR BOLTS AT LEAST 7". ALL BOLTS SHALL HAVE 3" x 3" x 0.229" PLATE WASHERS, THE PLATE WASHER SHALL EXTEND TO WITHIN 1/2" OF THE EDGE OF THE BOTTOM PLATE ON THE SIDE(S) w/ SHEATHING. AT 2x6 SW3-2 AND SW2-2 WALLS, PROVIDE 4-1/2" x 3" x 0.229" PLATE WASHERS CENTERED ON PLATE.
- 3x STUDS OR DBL STUDS NAILED TOGETHER w/ 10d NAILING ARE REQD AT ABUTTING PANEL EDGES WHERE PANEL EDGE NAIL SPACING IS 3"oc OR LESS. REFER TO DETAIL A, WHERE 3x STUDS ARE USED. STAGGER NAILS AT ADJOINING PANEL EDGES. ABUTTING PANEL EDGES SHALL BE OFFSET EACH SIDE OF DOUBLE-SIDED SHEARWALLS.
- TWO STUDS MINIMUM OR POST PER PLAN ARE REQUIRED AT EACH END OF ALL SHEARWALLS AND ALL END STUDS SHALL RECEIVE PANEL EDGE NAILING.
- ALL EXTERIOR WALLS SHALL BE SW6, UNLESS NOTED OTHERWISE.
- NAILS SHALL NOT BE SPACED LESS THAN 3/8" FROM EDGES OF SHEATHING. SHEATHING NAILS SHALL BE DRIVEN SO THEIR HEADS ARE FLUSH WITH SHEATHING (NOT COUNTERSUNK).
- MPA1s INSTALLED OVER SHEATHING WITH 8d (0.131"Ø x 2-1/2") NAILS MAY BE SUBSTITUTED FOR MPA1s AT CONTRACTORS OPTION.

**FLUSH BEAM SCHEDULE**

MARK	SIZE	BRG STUDS	HANGER
B1	GL 3-1/2 x 12	2	HD410
B2	GL 5-1/2 x 12	3	THDH610
B3	GL 3-1/2 x 15	2	HD412
B4	GL 5-1/2 x 15	3	THDH612
B5	GL 3-1/2 x 18	2	THDH414
B6	GL 5-1/2 x 18	3	THDH614
B7	GL 6-3/4 x 18	4	THDH614

- ALL GLULAM BEAMS ARE 24F-V4, UNO
- PROVIDE INVERTED FLANGE (IF) HANGERS WHERE REQUIRED, UNO



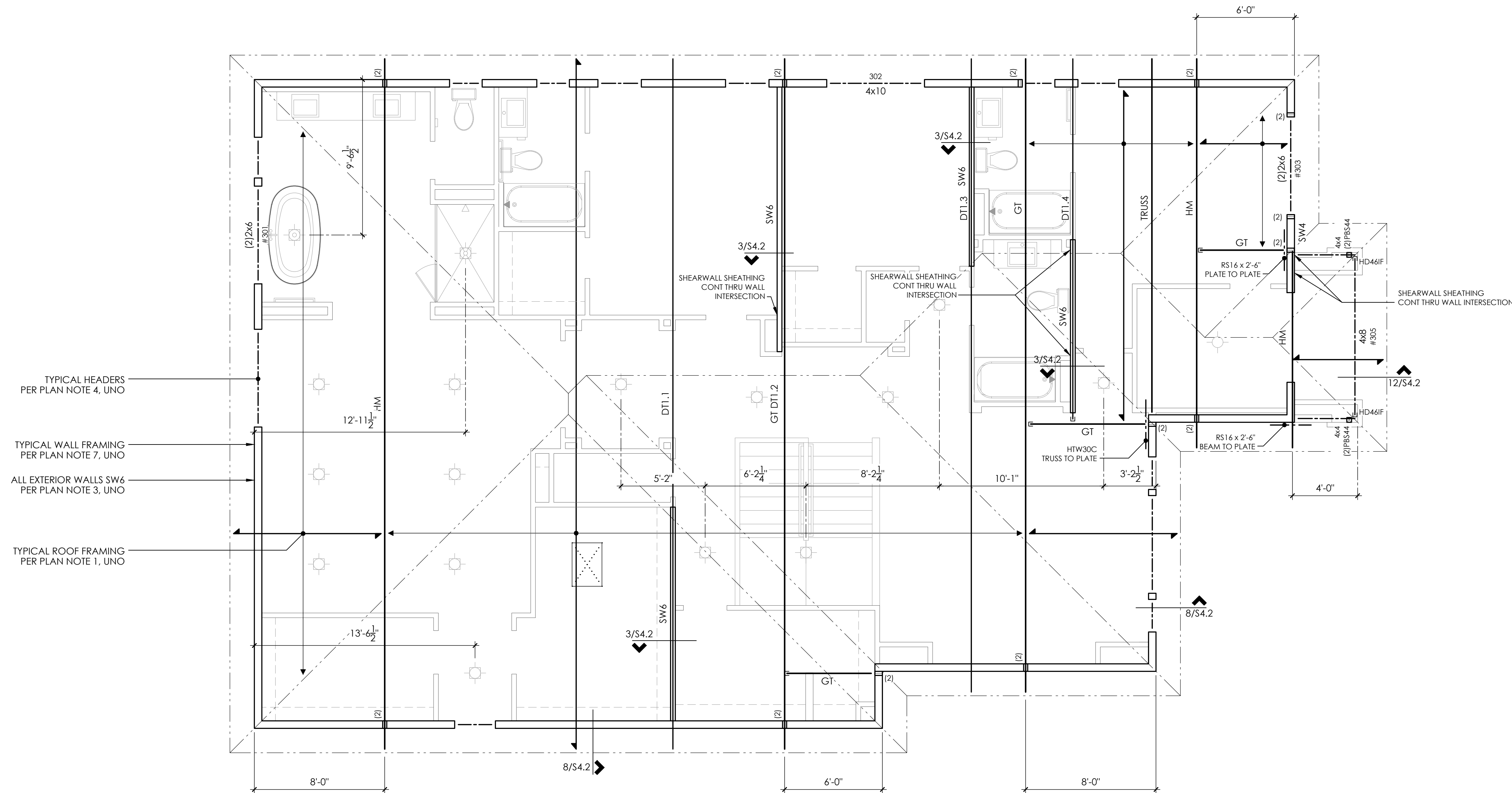

- TYPICAL HEADERS PER PLAN NOTE 4, UNO
- TYPICAL WALL FRAMING PER PLAN NOTE 7, UNO
- ALL EXTERIOR WALLS SW6 PER PLAN NOTE 3, UNO
- TYPICAL ROOF FRAMING PER PLAN NOTE 1, UNO

**PLAN NOTES**

1. TYPICAL ROOF FRAMING CONSISTS OF 7/16" or 1/2" APA RATED SHEATHING (SPAN RATING 32/16) OVER PRE-MANUFACTURED TRUSSES AT 24"oc, UNO. PROVIDE TIMBERLOK TLOK06 SCREWS EACH END OF ALL TRUSSES, AND EACH PLY OF ALL MULTIPLE TRUSSES, UNO. REFER TO ARCH DRAWINGS FOR TRUSS PROFILE. TRUSSES SHALL BEAR AT EXTERIOR WALLS ONLY, UNO. ALL OVERFRAMING SHALL BE PER TRUSS MANUFACTURER. GABLE END TRUSSES SHALL BE DESIGNED TO SPAN OPENINGS.
2. NAIL ROOF SHEATHING w/ 8d AT 6" oc AT FRAMED PANEL EDGES AND OVER SHEARWALLS, AND AT 12"oc IN FIELD, UNO.
3. "SW\_" INDICATES SHEARWALL BELOW FRAMING SHOWN. REFER TO SHEARWALL SCHEDULE ON 4/S4.0 FOR ADDITIONAL INFORMATION. ALL EXTERIOR WALLS ARE SW6, UNO.
4. ALL HEADERS SHALL BE (2)2x6, UNO. REFER TO DETAIL 8/S4.0 FOR ADDITIONAL REQUIREMENTS.
5. PROVIDE (2)BEARING (TRIMMER) STUDS AT EACH END OF ALL HEADERS, BEAMS, AND GIRDER TRUSSES OVER 6'-0" IN LENGTH, UNO.
6. WHERE POSTS OCCUR, PROVIDE SOLID VERTICAL GRAIN BLOCKING THRU FLOOR TO MATCHING SUPPORTS BELOW, UNO.
7. TYPICAL WALL FRAMING CONSISTS OF 2x6's AT 16"oc AT EXTERIOR WALLS AND 2x4's or 2x6's AT 16"oc AT INTERIOR WALLS PER ARCH DRAWINGS, UNO.
8. RECESSED LIGHTING AND ATTIC ACCESS LOCATIONS ARE PROVIDED BY ARCHITECT AND DIMENSIONS SHALL BE VERIFIED.
9. REFER TO SHEET S4.0 FOR TYPICAL WOOD FRAMING DETAILS.
10. REFER TO GENERAL STRUCTURAL NOTES SHEET S1.0 FOR ADDITIONAL REQUIREMENTS.
11. DO NOT SCALE DRAWINGS. REFER TO ARCH DRAWINGS FOR ALL DIMENSIONS.
12. PROVIDE FOR ALL TEMPORARY AND PERMANENT TRUSS BRACING AND BRIDGING PER IRC R802.10.3 AND THE TRUSS PLATE INSTITUTES BUILDING COMPONENT SAFETY INFORMATION.

**LEGEND**

- STRUCTURAL WALL BELOW
- SPAN AND EXTENTS
- HEADER/BEAM BELOW FRAMING - TYP
- (X) NUMBER OF BUILT UP STUDS
- GT GIRDER TRUSS
- HM HIP MASTER
- KS FULL HEIGHT KING STUD w/ MPA1 TOP AND BOTTOM
- TS TRIMMER STUD
- RECESSED LIGHTING

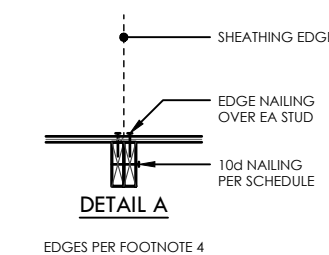

**SHEARWALL SCHEDULE**

MARK	SHEATHING	PANEL EDGE NAILING	TOP PLATE CONNECTION		BASE PLATE CONNECTION	
			I-JOIST	RIM/BEAM	AT WOOD	AT CONCRETE
SW6	1/2" PLY or 7/16" OSB	8d AT 6"oc	10d AT 6"oc	MPA1 AT 30"oc	12d AT 6"oc	5/8" AB AT 48"oc
SW4	1/2" PLY or 7/16" OSB	8d AT 4"oc	10d AT 4"oc	MPA1 AT 18"oc	12d AT 4"oc	5/8" AB AT 42"oc
SW3	1/2" PLY or 7/16" OSB	8d AT 3"oc	(2)ROWS 10d AT 6"oc	MPA1 AT 16"oc	(2)ROWS 12d AT 6"oc	5/8" AB AT 36"oc
SW2	1/2" PLY or 7/16" OSB	8d AT 2"oc	(2)ROWS 10d AT 4"oc	MPA1 AT 12"oc	(2)ROWS 12d AT 4"oc	5/8" AB AT 24"oc
SW3-2	1/2" PLY or 7/16" OSB EA SIDE	8d AT 3"oc EA SIDE	N/A	MPA1 AT 8"oc	(2)ROWS 12d AT 3"oc	5/8" AB AT 18"oc
SW2-2	1/2" PLY or 7/16" OSB EA SIDE	8d AT 2"oc EA SIDE	N/A	MPA1 AT 6"oc	(3)ROWS 12d AT 3"oc	5/8" AB AT 12"oc

- 1. BLOCK PANEL EDGES WITH 2x4 LAID FLAT AND NAIL PANELS TO INTERMEDIATE SUPPORTS WITH 8d AT 12"oc.
- 2. 8d NAILS SHALL BE 0.131"Ø x 2-1/2"; 10d NAILS SHALL BE 0.131"Ø x 3"; AND 12d NAILS SHALL BE 0.131"Ø x 3-1/4".
- 3. EMBED ANCHOR BOLTS AT LEAST 7". ALL BOLTS SHALL HAVE 3" x 3" x 0.229" PLATE WASHERS. THE PLATE WASHER SHALL EXTEND TO WITHIN 1/2" OF THE EDGE OF THE BOTTOM PLATE ON THE SIDE(S) w/ SHEATHING. AT 2x6 SW3-2 AND SW2-2 WALLS, PROVIDE 4-1/2" x 3" x 0.229" PLATE WASHERS CENTERED ON PLATE.
- 4. 3x STUDS OR DBL STUDS NAILED TOGETHER w/ 10d NAILING ARE REQD AT ABUTTING PANEL EDGES WHERE PANEL EDGE NAIL SPACING IS 3"oc OR LESS. REFER TO DETAIL A. WHERE 3x STUDS ARE USED, STAGGER NAILS AT ADJOINING PANEL EDGES. ABUTTING PANEL EDGES SHALL BE OFFSET EACH SIDE OF DOUBLE-SIDED SHEARWALLS.
- 5. TWO STUDS MINIMUM OR POST PER PLAN ARE REQUIRED AT EACH END OF ALL SHEARWALLS AND ALL END STUDS SHALL RECEIVE PANEL EDGE NAILING.
- 6. ALL EXTERIOR WALLS SHALL BE SW6, UNLESS NOTED OTHERWISE.
- 7. NAILS SHALL NOT BE SPACED LESS THAN 3/8" FROM EDGES OF SHEATHING. SHEATHING NAILS SHALL BE DRIVEN SO THEIR HEADS ARE FLUSH WITH SHEATHING (NOT COUNTERSUNK).
- 8. MPA1'S INSTALLED OVER SHEATHING WITH 8d (0.131"Ø x 2-1/2") NAILS MAY BE SUBSTITUTED FOR MPA1'S AT CONTRACTORS OPTION.

**ROOF FRAMING PLAN**

UPPER FLOOR WALLS SHOWN SOLID

**DRAG TRUSS SCHEDULE**

MARK	LOAD TRANSFER
DT1.1	1.5 KIPS
DT1.2	1.8 KIPS
DT1.3	1.2 KIPS
DT1.4	1.2 KIPS

- 1. TRUSS MFR TO DESIGN TRUSS TO TRANSFER LISTED LOAD FROM TOP TO BOT CHORD
- 2. NAIL THRU SHEATHING w/ 8d AT 4"oc INTO ENTIRE LENGTH OF MEMBER
- 3. DRAG TRUSSES ARE NOT REQUIRED DIRECTLY ABOVE SHEARWALLS, UNO
- 4. ADDITIONAL R7A EA END OF DRAG TRUSS

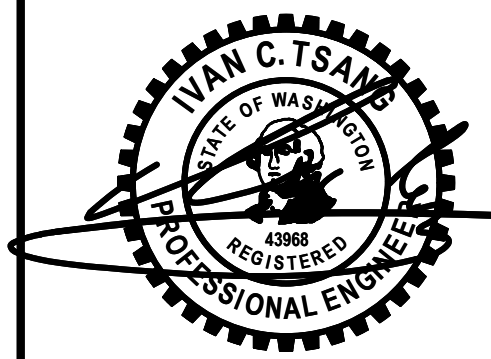

PROJECT NO 0135.2020.12.0306  
PROJECT MANAGER RAF  
DRAWN JSD  
ENGINEER NATE MOORE  
NATEM@MALSAM-TSANG.COM

REV	DESCRIPTION	DATE
PERMIT SET		7.6.23

ARCH MAINVUE HOMES  
425.646.4022

**ROOF FRAMING PLAN**

**S2.3**  
SCALE - 1/4" = 1'-0"

**APPROVED**  
Plans Reviewed by **SAFEbuilt**  
For Building Code Compliance  
Reviewed By: **Bobby Thomas** CBO, Plans Examiner,  
Combination Inspector  
Date: **7/20/2023 REV 1**



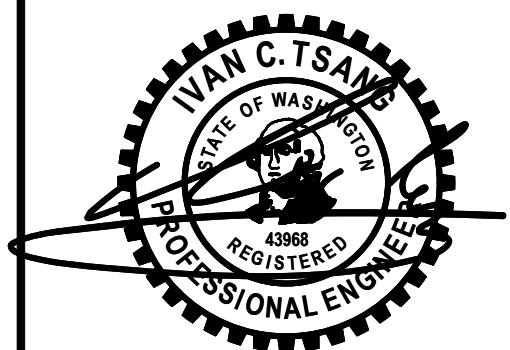

PROJECT NO 0135.2020.12.0306  
PROJECT MANAGER RAF  
DRAWN JSD  
ENGINEER NATE MOORE  
206.602.9537  
NATEM@MALSAM-TSANG.COM

REV	DESCRIPTION	DATE
PERMIT SET		7.6.23

ARCH MAINVUE HOMES  
425.646.4022

TYPICAL CONCRETE  
DETAILS

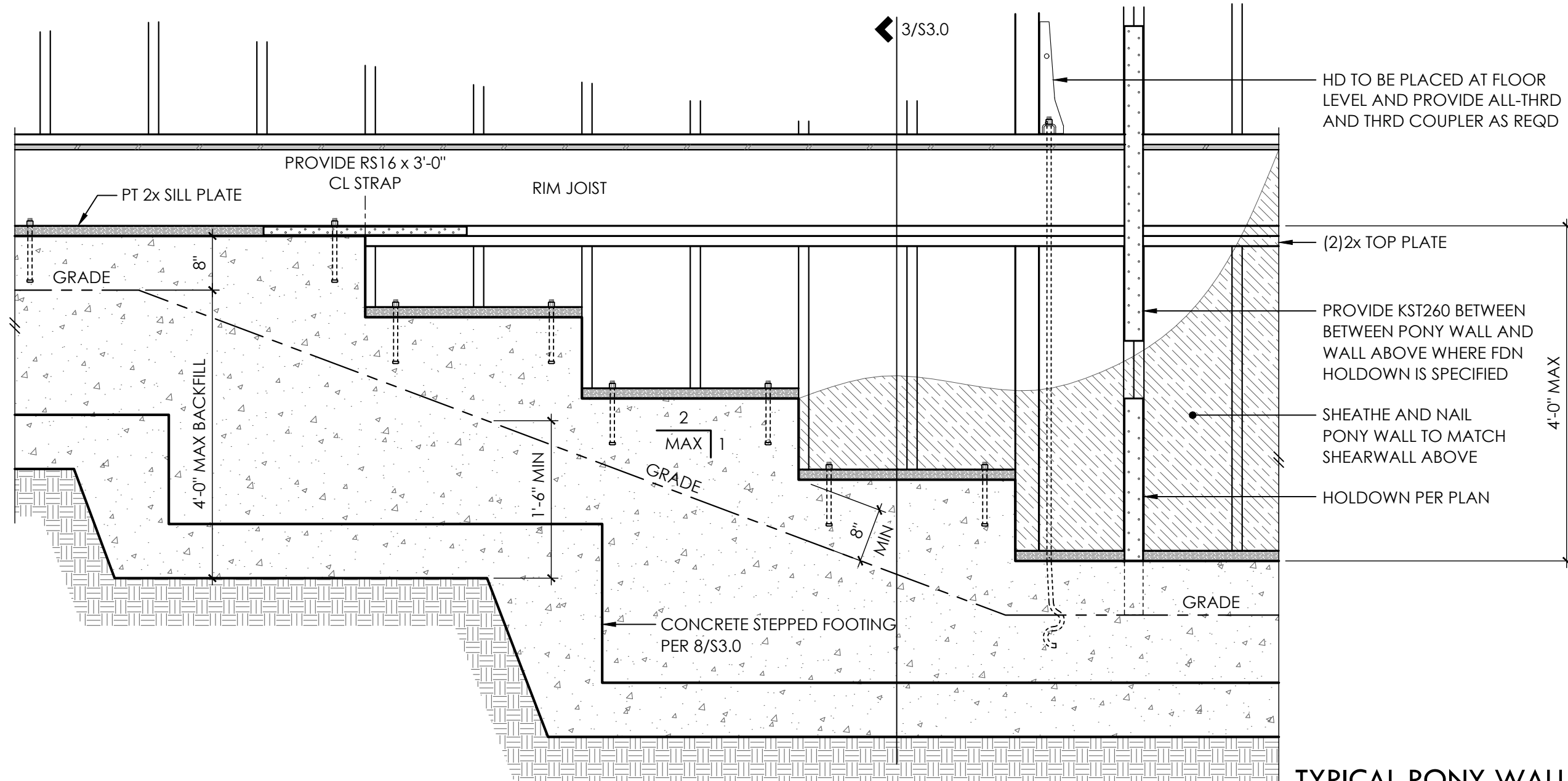

TYPICAL PONY WALLS 2

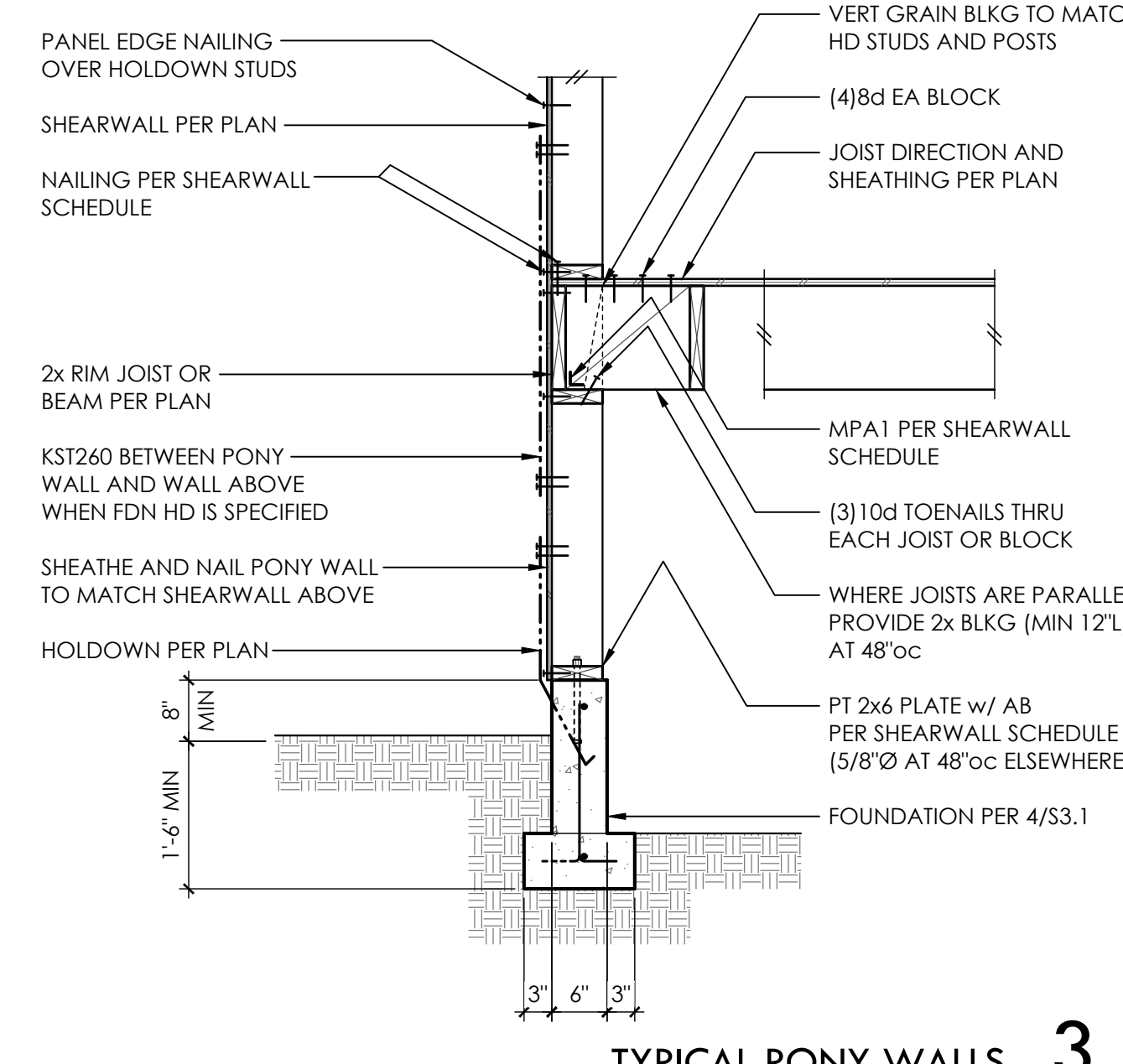

TYPICAL PONY WALLS 3

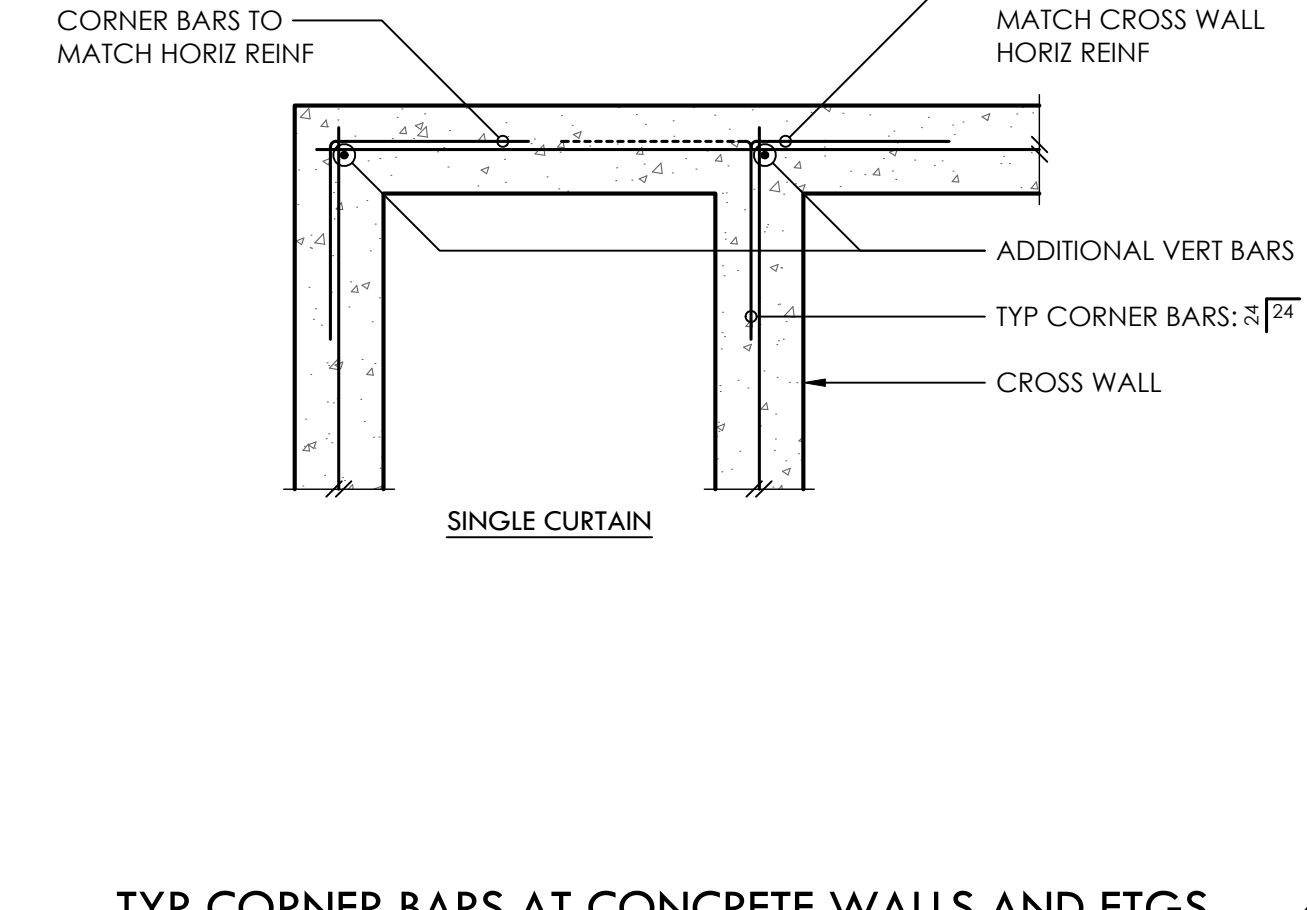

TYP CORNER BARS AT CONCRETE WALLS AND FTGS 4

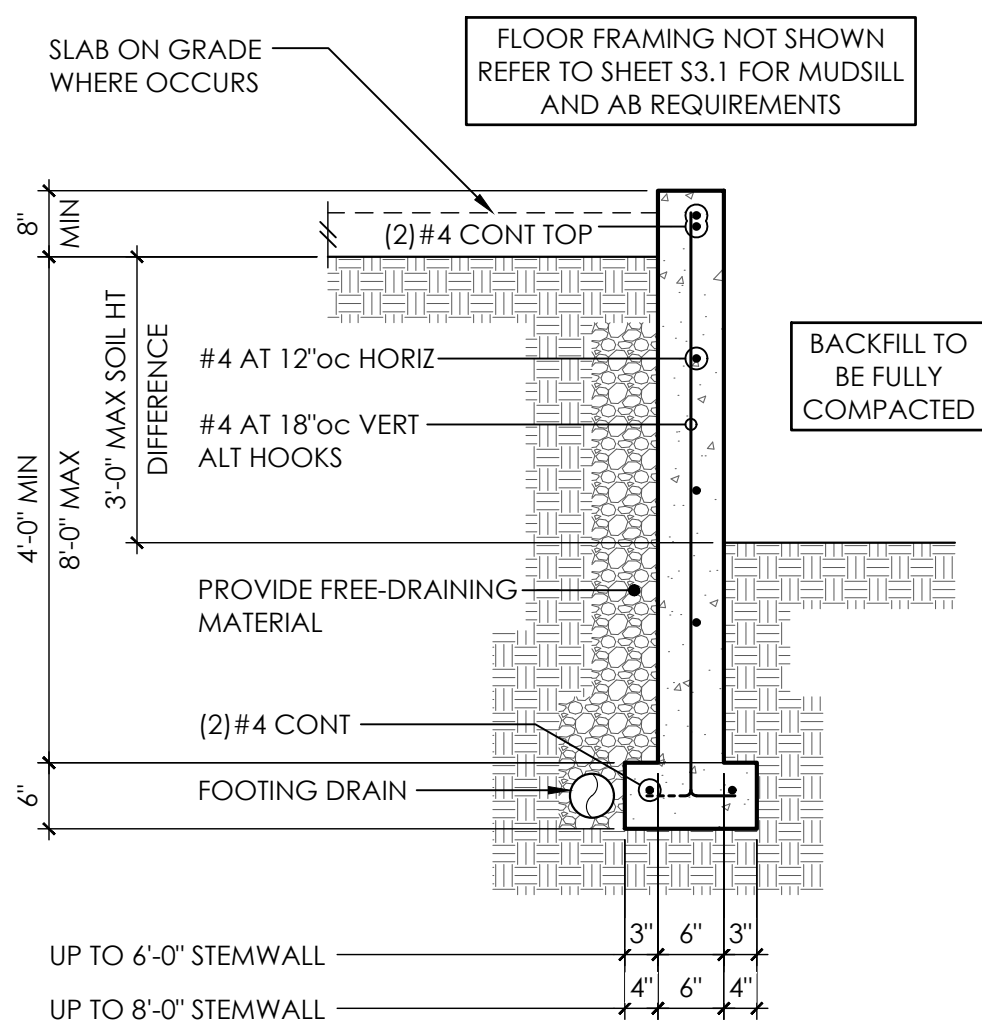

5

TYPICAL DEEP FOOTING 6

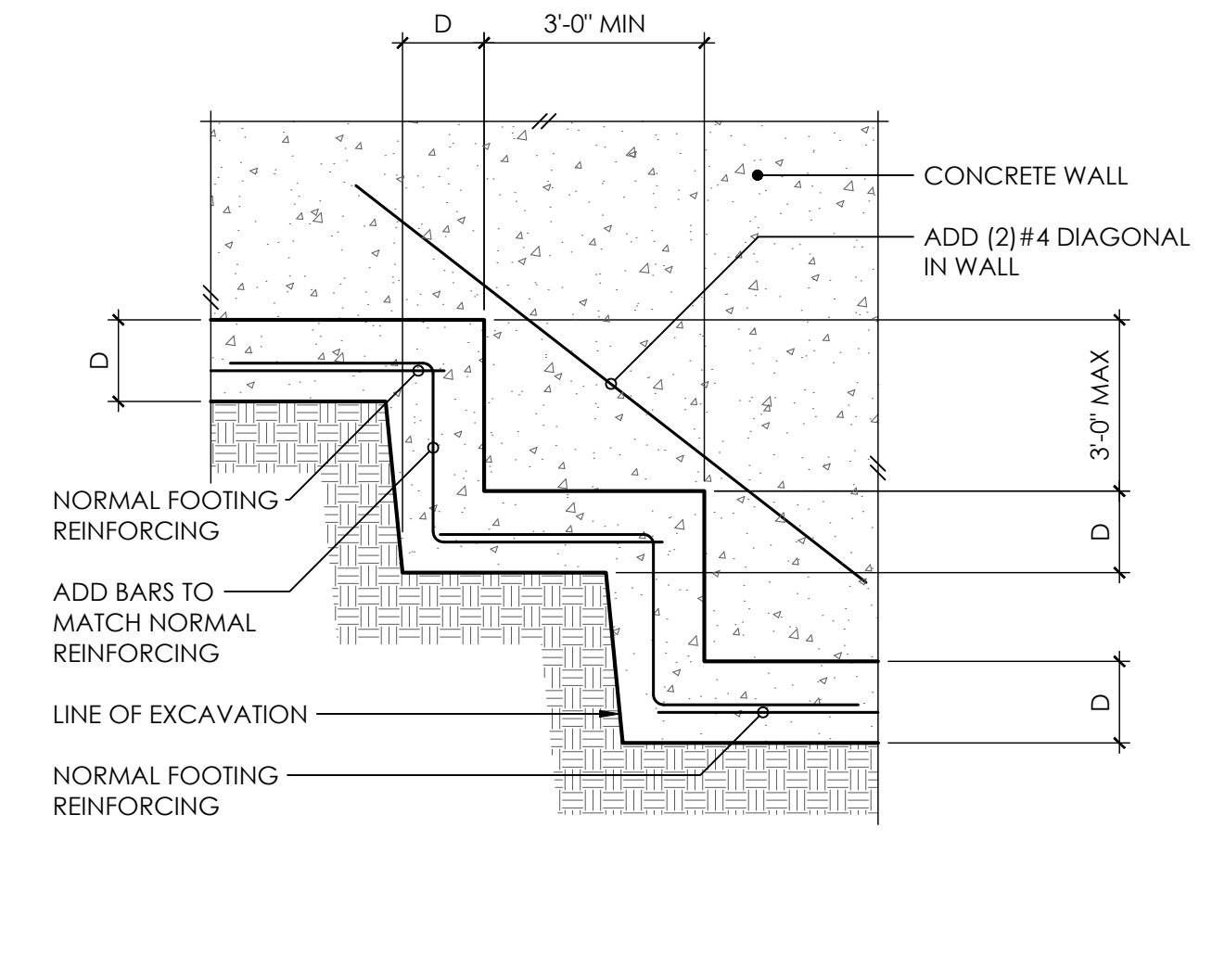

TYPICAL STEPPED FOOTING 7

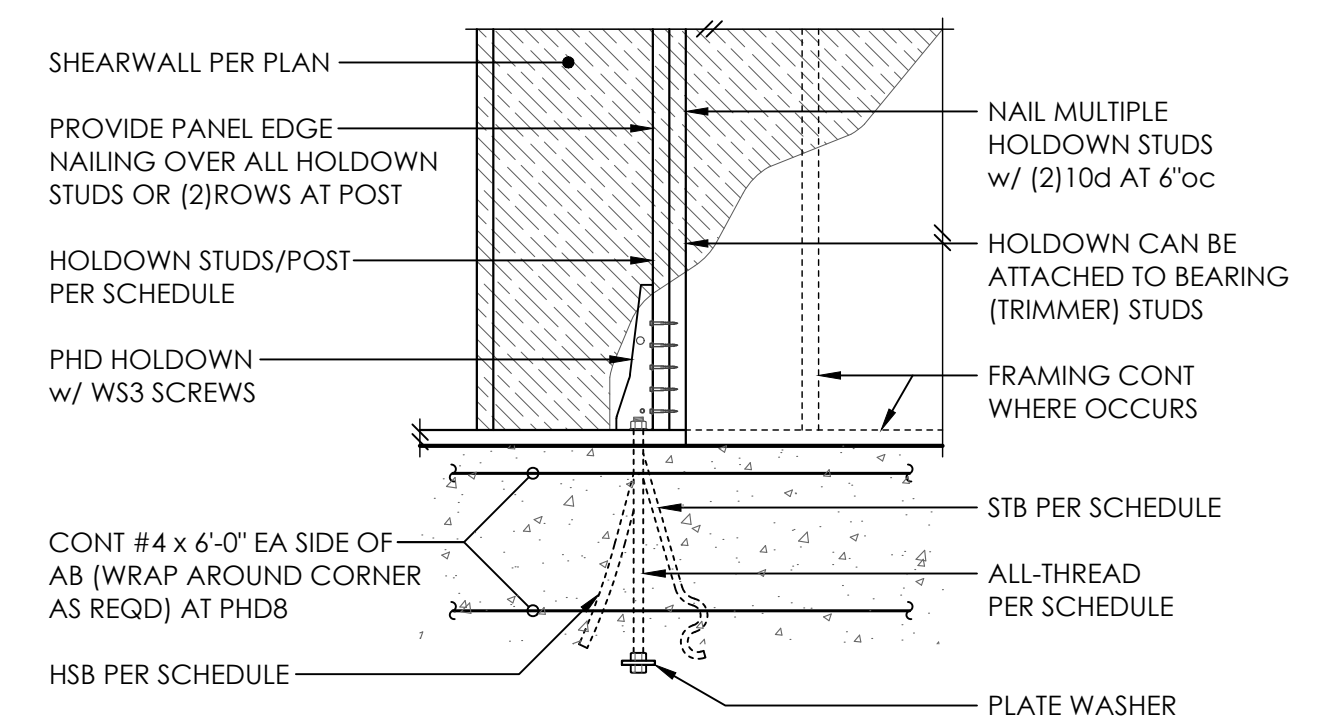

**PHD HOLDOWN SCHEDULE**

PLAN MARK	AT STEMWALL		AT FOOTING		HD POST	
	AB	EMBED	ALL-THREAD	WASHER	EMBED	4x WALL 6x WALL
PHD2A	5/8"Ø - STB16	12-13/16"	5/8"Ø	1-3/4"SQ x 1/2	9"	(2)2x4 (2)2x6
PHD4A	5/8"Ø - STB20	14-13/16"	5/8"Ø	1-3/4"SQ x 1/2	9"	(2)2x4 (2)2x6
PHD5A	5/8"Ø - STB24	20-13/16"	5/8"Ø	1-3/4"SQ x 1/2	9"	(2)2x4 (2)2x6
PHD8	3/4"Ø - HSB24	19-1/2"	7/8"Ø	2-1/2"SQ x 1/2	12"	4x6 6x6

- ⊙ A307 ALL-THREAD w/ PLATE WASHER PER SCHEDULE AND DOUBLE NUT BOTTOM
- ⊙ MINIMUM SIZE OF POST UNO ON FRAMING PLANS
- ⊙ PROVIDE (2)VERTICAL #4 w/ STANDARD HOOK INTO FOOTINGS AT EACH HSB

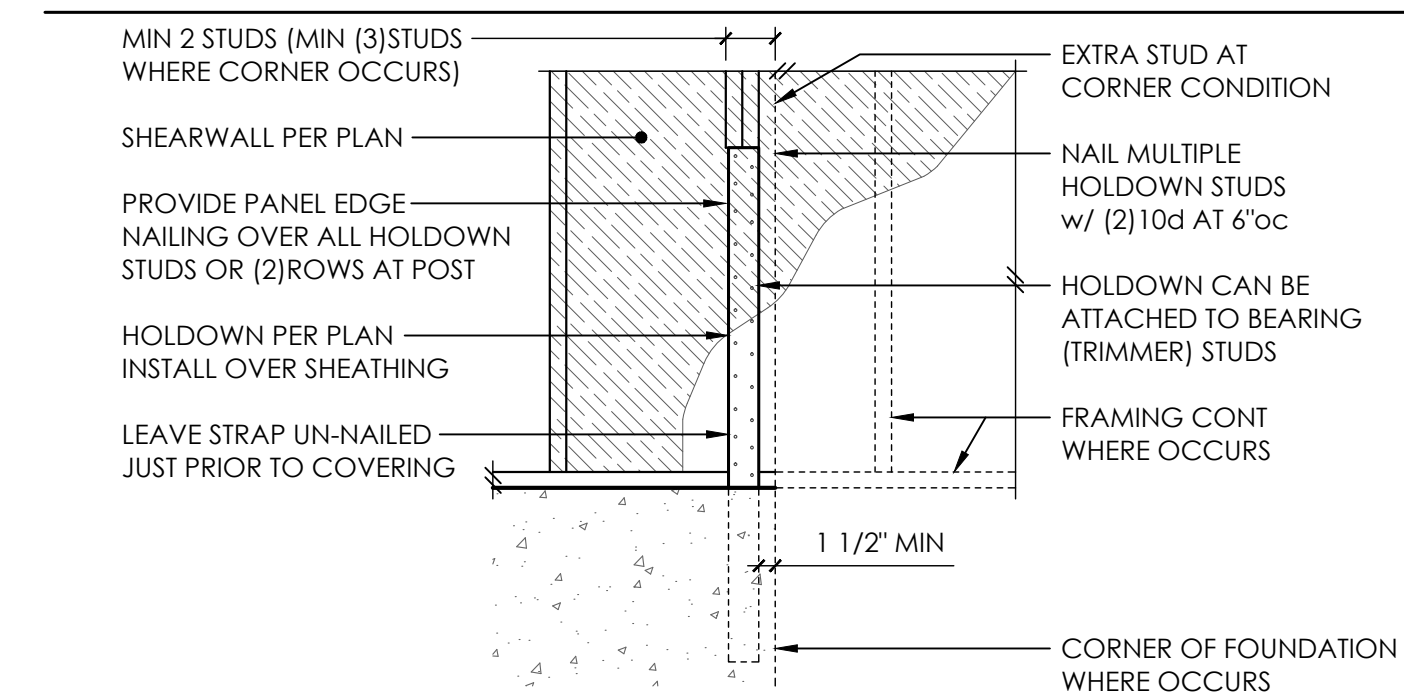

**STAD HOLDOWN SCHEDULE**

PLAN MARK	NAILS	HD POST
STAD8(RJ)	(24) 16d SINKERS	DBL STUD
STAD10(RJ)	(28) 16d SINKERS	DBL STUD
STAD14(RJ)	(38) 16d SINKERS	DBL STUD

- ⊙ 16d SINKERS = 0.148"Ø x 3-1/4"
- ⊙ MINIMUM SIZE OF POST UNO ON FRAMING PLANS



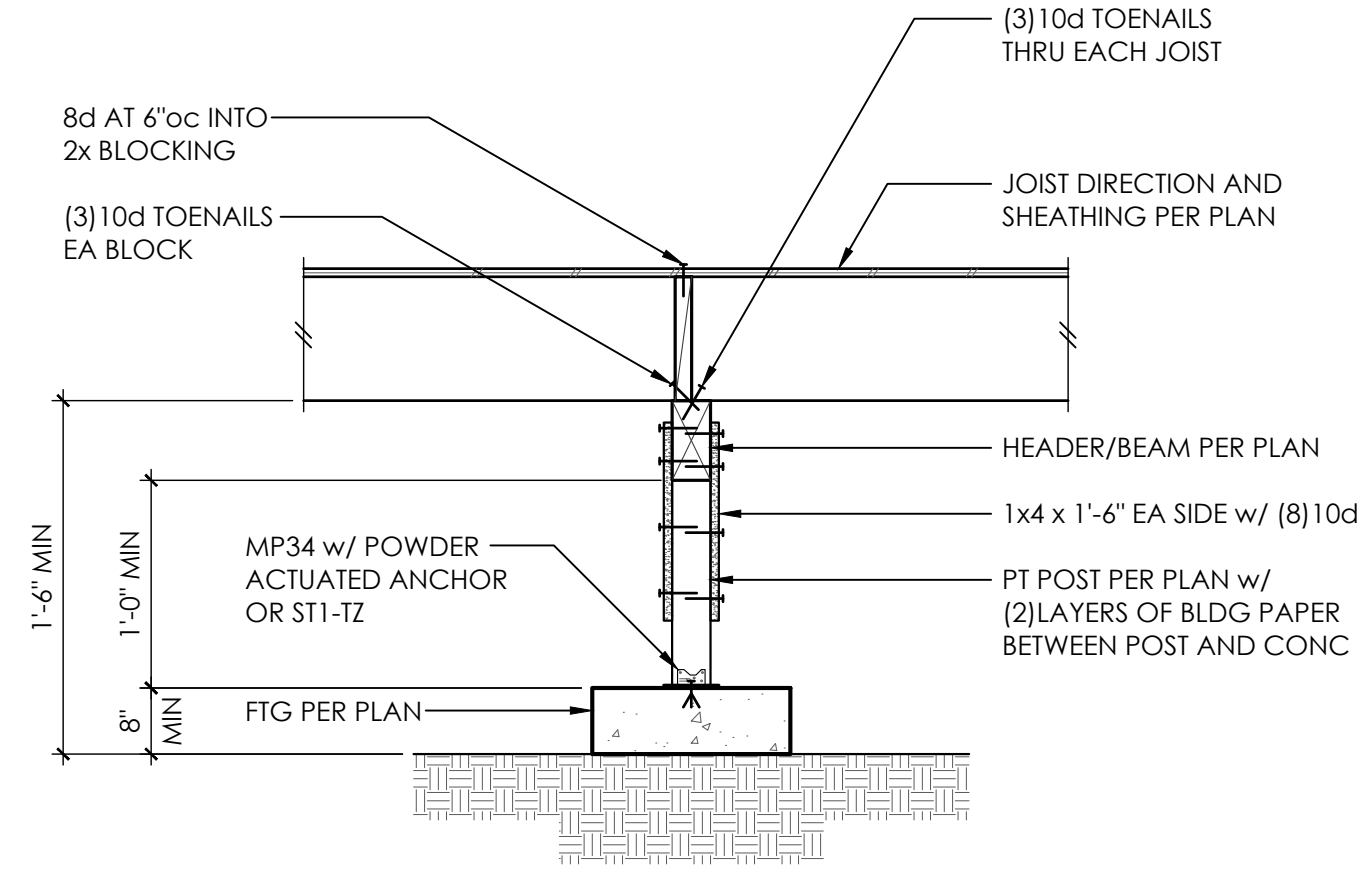

1

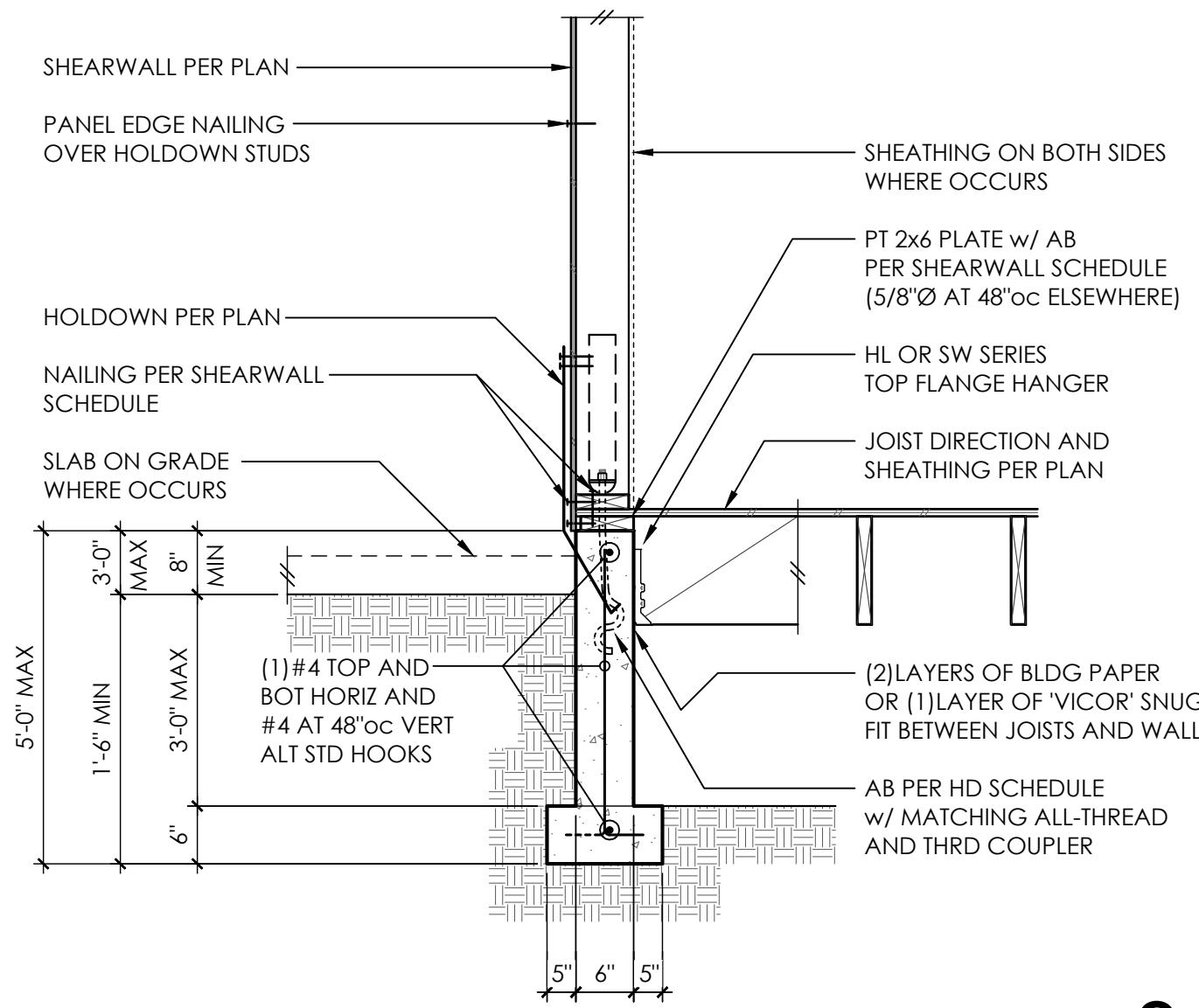

2

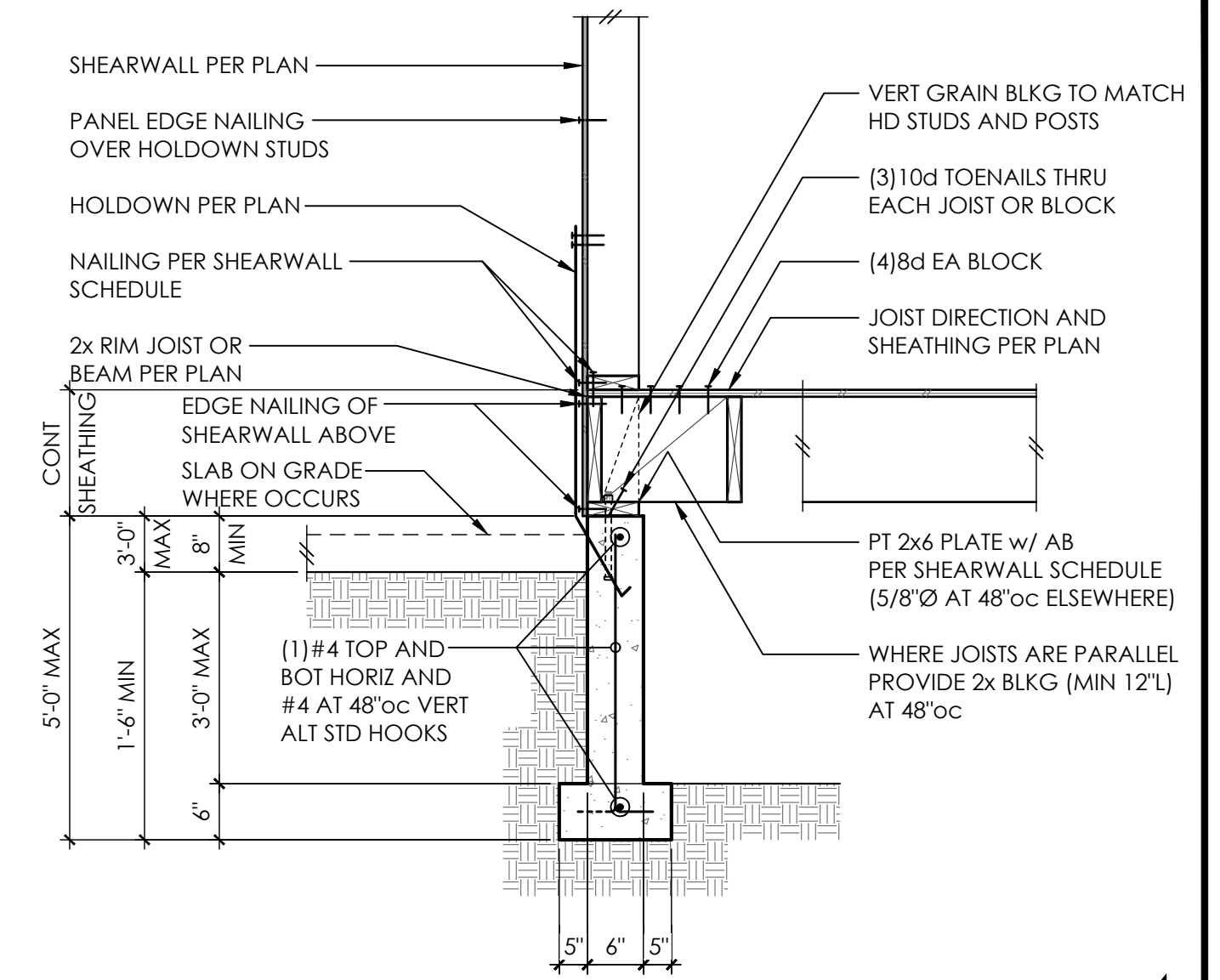

3

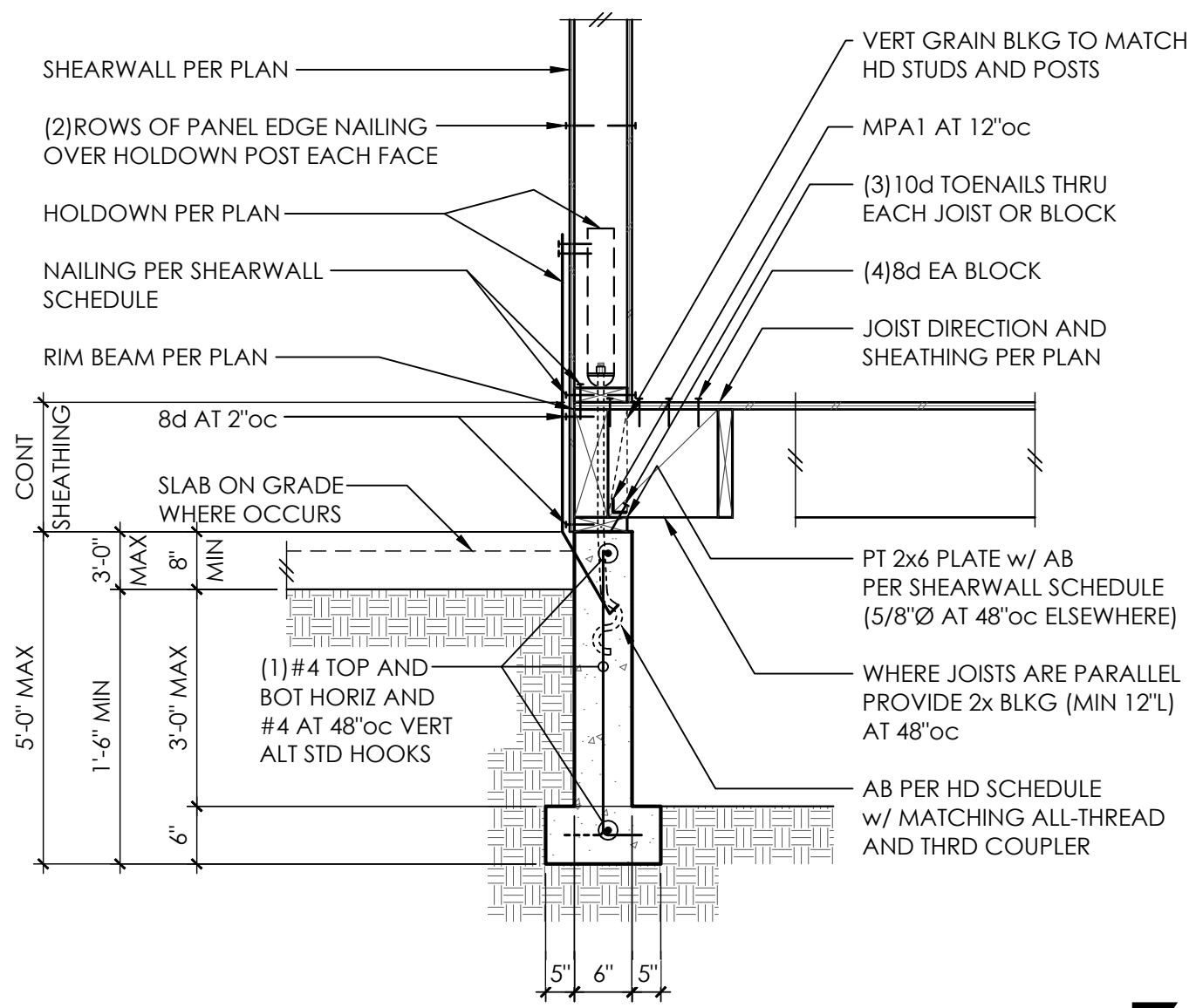

4

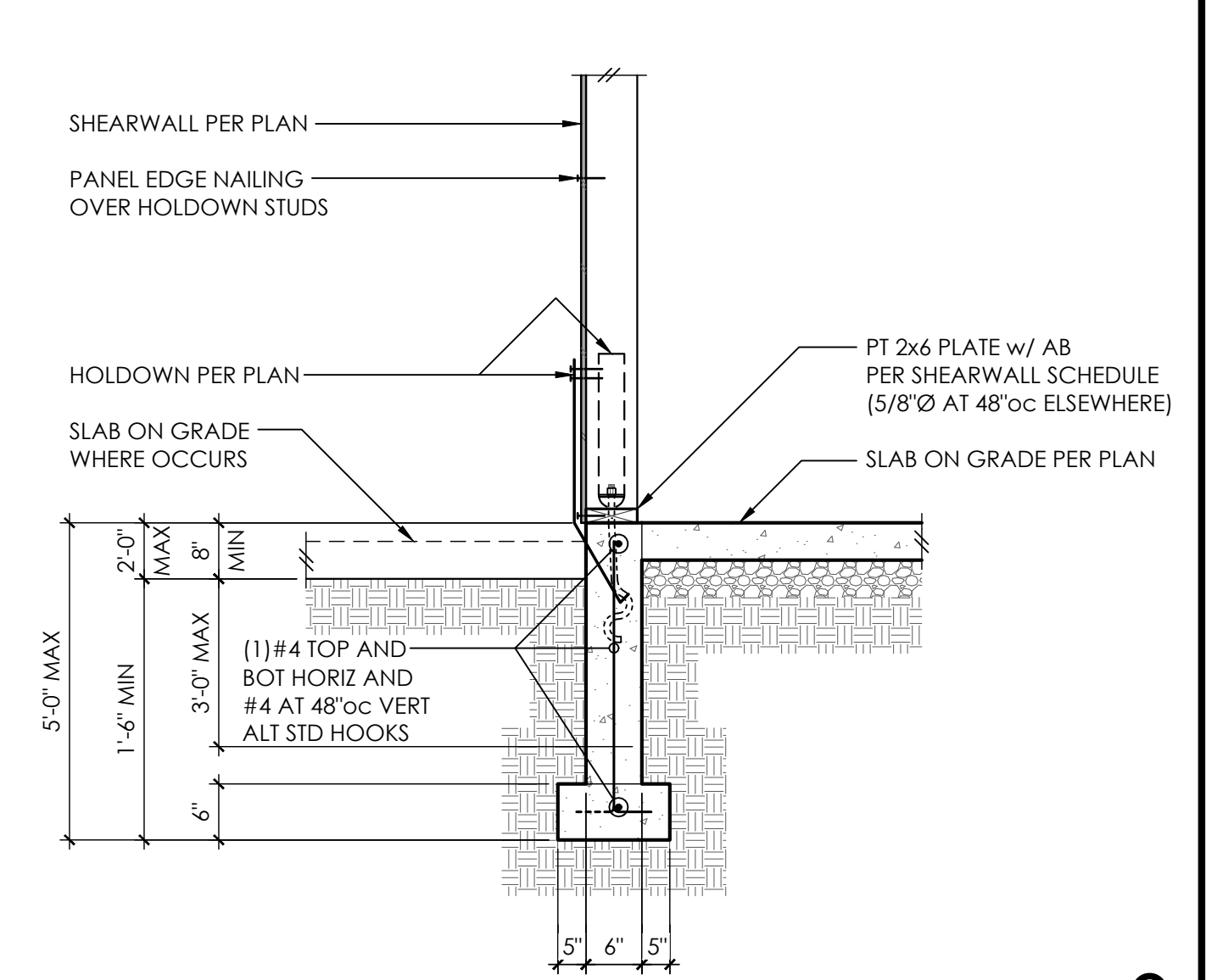

5

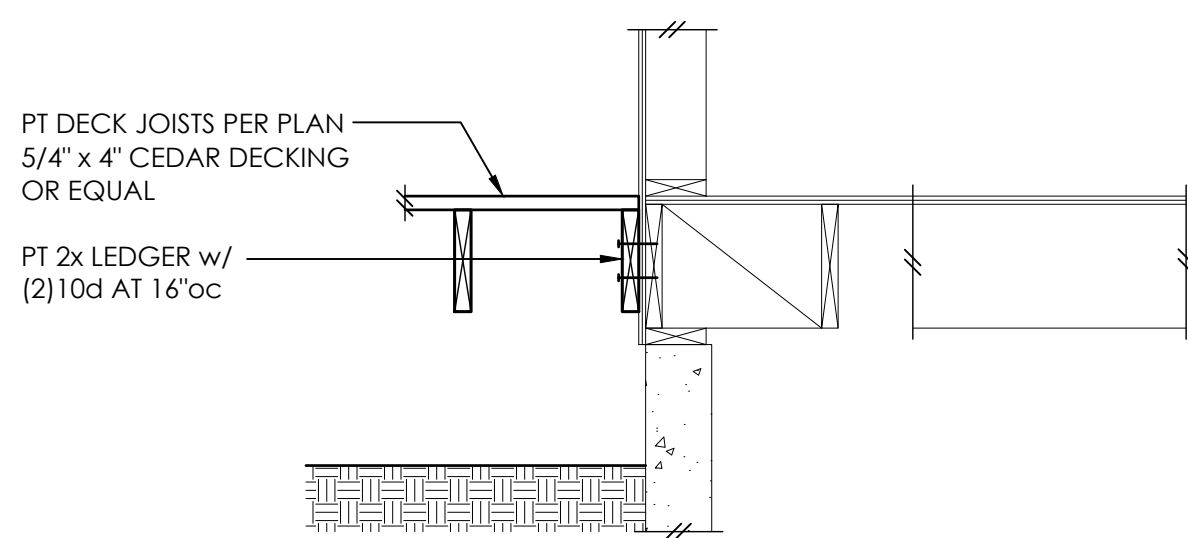

DECK JOISTS PARALLEL TO RIM

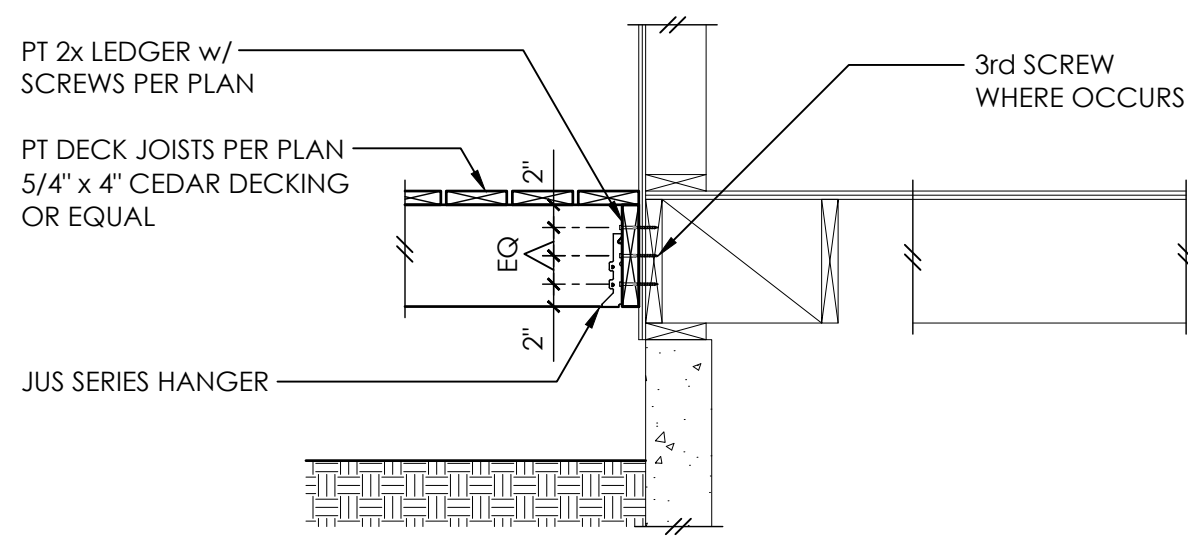

DECK JOISTS PERPENDICULAR TO RIM

6

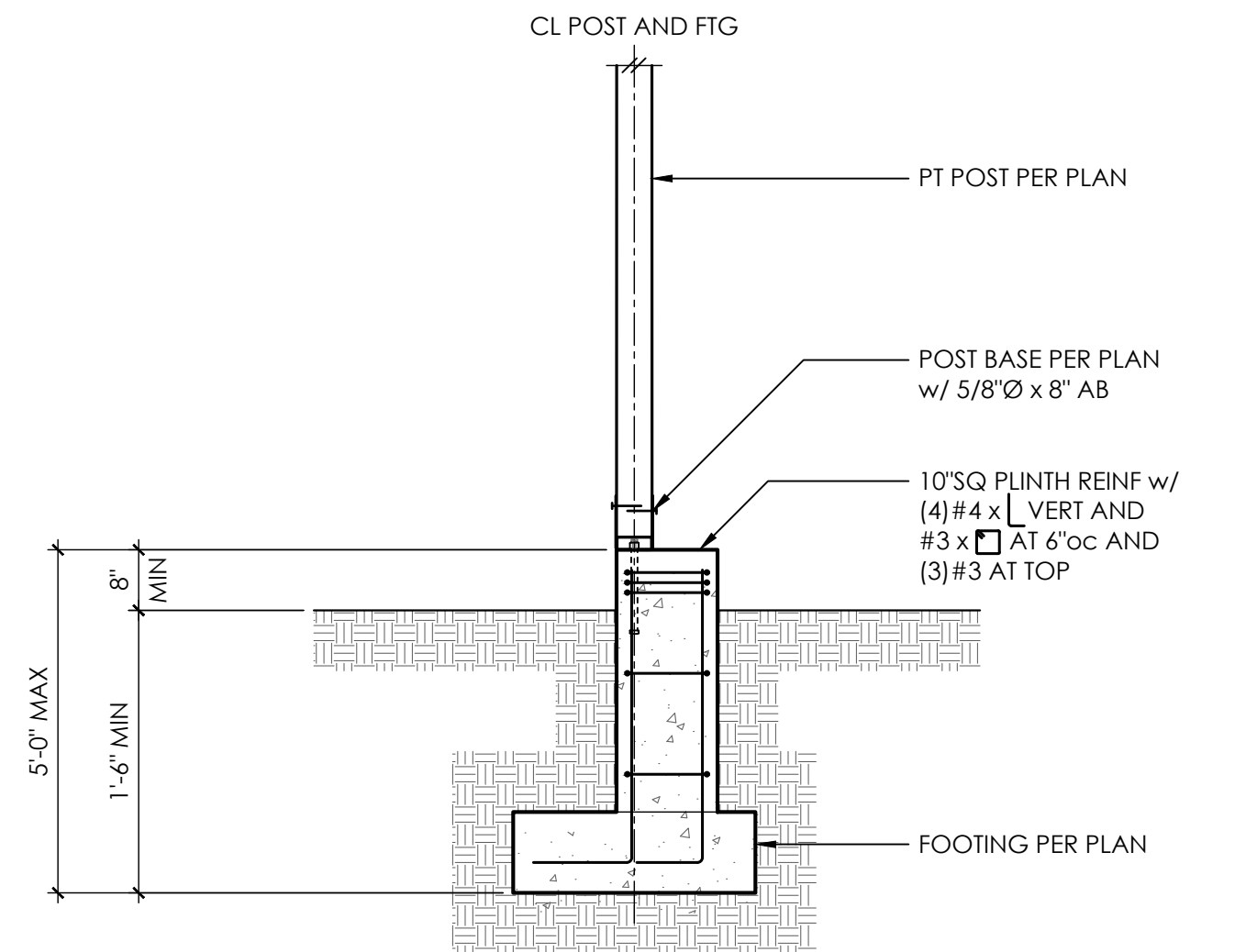

7

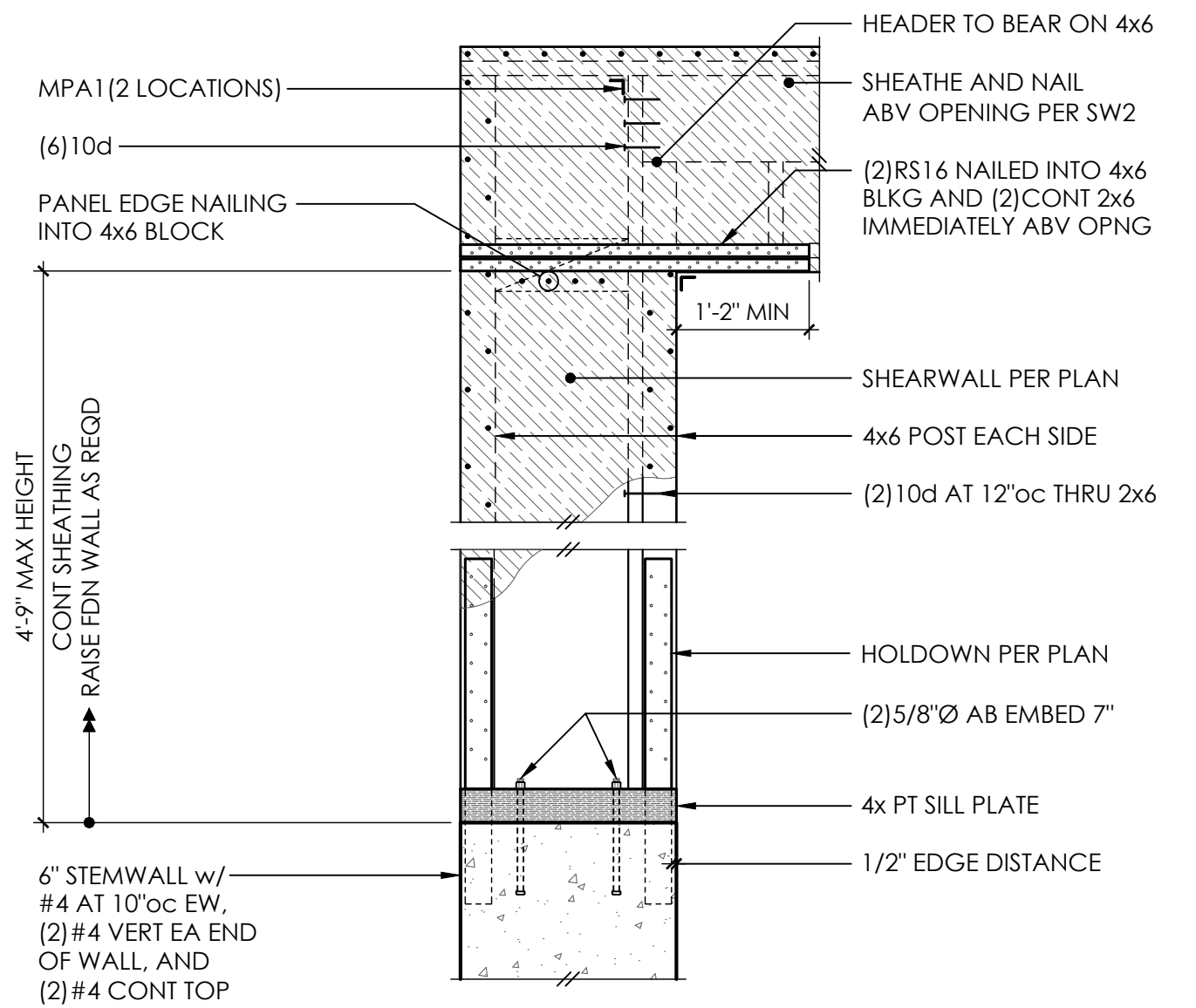

8

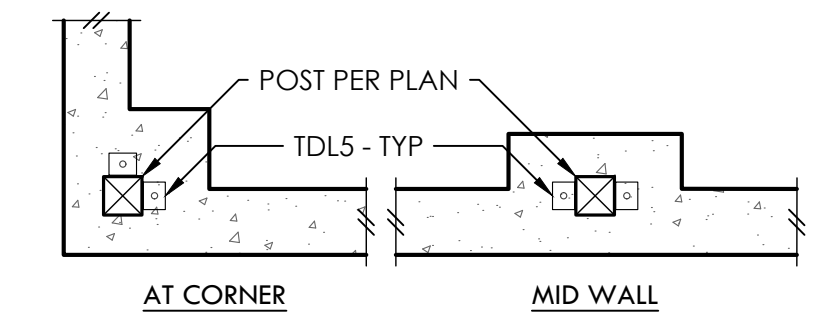

PLAN VIEW

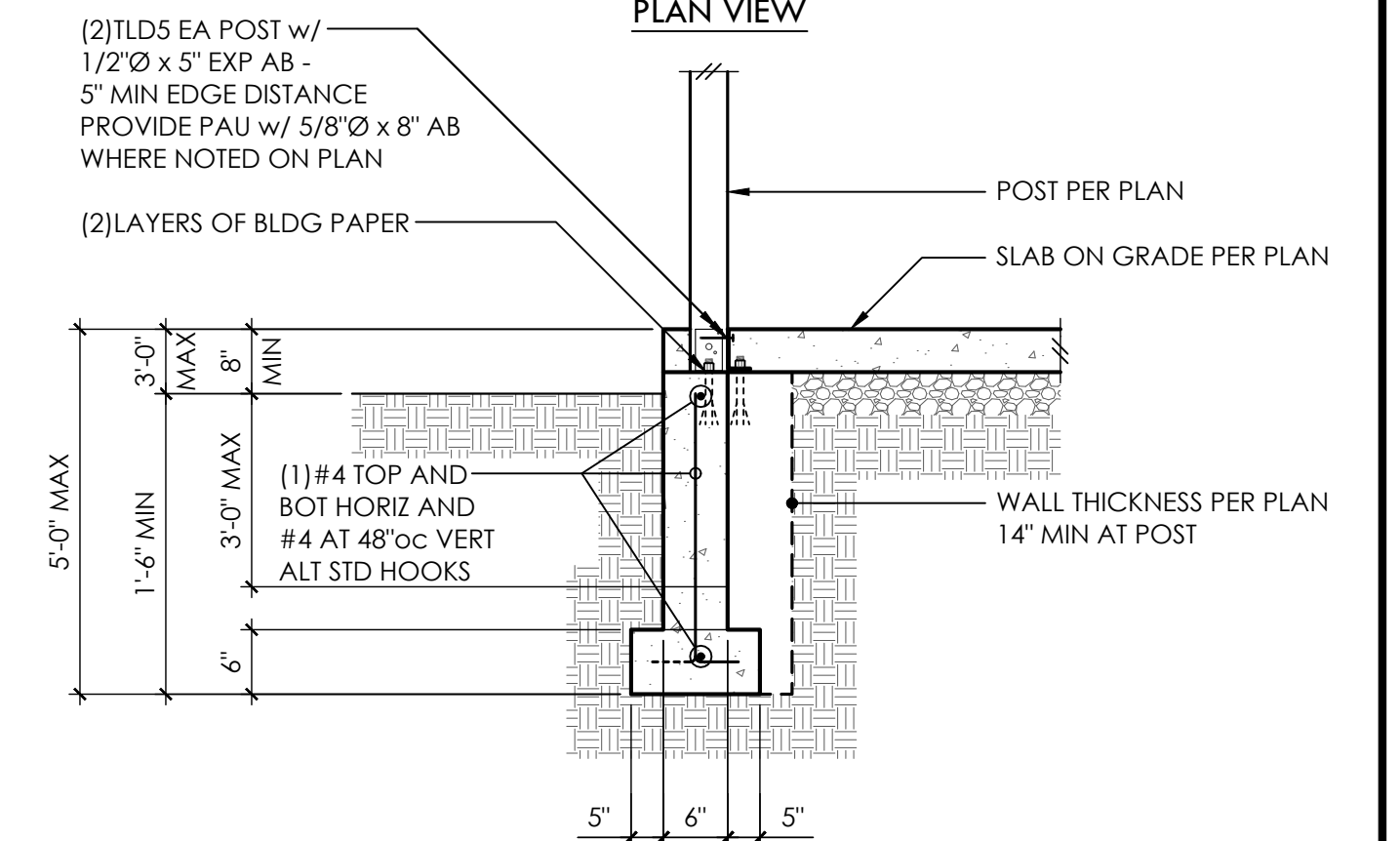

9

APPROVED  
Plans Reviewed by SAFEbuilt LLC  
For Building Code Compliance  
Reviewed By:  
Bobby Thomas CBO, Plans Examiner,  
Combination Inspector  
Date:  
7/20/2023 REV 1



PROJECT NO 0135.2020.12.0306  
PROJECT MANAGER RAF  
DRAWN JSD  
ENGINEER NATE MOORE  
206.602.9537  
NATEM@MALSAM-TSANG.COM

REV	DESCRIPTION	DATE
PERMIT SET		7.6.23

ARCH MAINVUE HOMES  
425.646.4022

CONCRETE DETAILS



**APPROVED**  
Plans Reviewed by **SAFEbuilt** LLC  
For Building Code Compliance  
Reviewed By: **Bobby Thomas CBO**, Plans Examiner,  
Combination Inspector  
Date: **7/20/2023 REV 1**

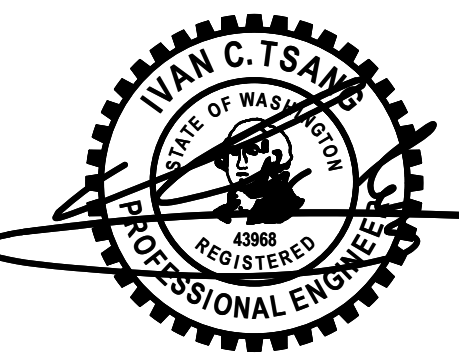

PROJECT NO	0135.2020.12.0306	PROJECT MANAGER	RAF
DRAWN	JSD	ENGINEER	NATE MOORE
			206.602.9537
			NATEM@MALSAM-TSANG.COM
REV	DESCRIPTION	DATE	
	PERMIT SET	7.6.23	
ARCH	MAINVUE HOMES		425.646.4022

**TYPICAL WOOD FRAMING DETAILS**

**SHEARWALL SCHEDULE**

MARK	SHEATHING	PANEL EDGE NAILING	TOP PLATE CONNECTION		BASE PLATE CONNECTION	
			I-JOIST	RIM/B EAM	AT WOOD	AT CONCRETE
SW6	1/2" PLY or 7/16" OSB	8d AT 6"oc	10d AT 6"oc	MPA1 AT 30"oc	12d AT 6"oc	5/8" AB AT 48"oc
SW4	1/2" PLY or 7/16" OSB	8d AT 4"oc	10d AT 4"oc	MPA1 AT 18"oc	12d AT 4"oc	5/8" AB AT 42"oc
SW3	1/2" PLY or 7/16" OSB	8d AT 3"oc	(2)ROWS 10d AT 6"oc	MPA1 AT 16"oc	(2)ROWS 12d AT 6"oc	5/8" AB AT 36"oc
SW2	1/2" PLY or 7/16" OSB	8d AT 2"oc	(2)ROWS 10d AT 4"oc	MPA1 AT 12"oc	(2)ROWS 12d AT 4"oc	5/8" AB AT 24"oc
SW3-2	1/2" PLY or 7/16" OSB EA SIDE	8d AT 3"oc EA SIDE	N/A	MPA1 AT 8"oc	(2)ROWS 12d AT 3"oc	5/8" AB AT 18"oc
SW2-2	1/2" PLY or 7/16" OSB EA SIDE	8d AT 2"oc EA SIDE	N/A	MPA1 AT 6"oc	(3)ROWS 12d AT 3"oc	5/8" AB AT 12"oc

- 1 BLOCK PANEL EDGES WITH 2x4 LAID FLAT AND NAIL PANELS TO INTERMEDIATE SUPPORTS WITH 8d AT 12"oc.
- 2 8d NAILS SHALL BE 0.131"Ø x 2-1/2", 10d NAILS SHALL BE 0.131"Ø x 3", AND 12d NAILS SHALL BE 0.131"Ø x 3-1/4".
- 3 EMBED ANCHOR BOLTS AT LEAST 7". ALL BOLTS SHALL HAVE 3" x 3" x 0.229" PLATE WASHERS. THE PLATE WASHER SHALL EXTEND TO WITHIN 1/2" OF THE EDGE OF THE BOTTOM PLATE ON THE SIDE(S) w/ SHEATHING. AT 2x6 SW3-2 AND SW2-2 WALLS, PROVIDE 4-1/2" x 3" x 0.229" PLATE WASHERS CENTERED ON PLATE.
- 4 3x STUDS OR DBL STUDS NAILED TOGETHER w/ 10d NAILING ARE REQD AT ABUTTING PANEL EDGES WHERE PANEL EDGE NAIL SPACING IS 3"oc OR LESS. REFER TO DETAIL A. WHERE 3x STUDS ARE USED, STAGGER NAILS AT ADJOINING PANEL EDGES. ABUTTING PANEL EDGES SHALL BE OFFSET EACH SIDE OF DOUBLE-SIDED SHEARWALLS.
- 5 TWO STUDS MINIMUM OR POST PER PLAN ARE REQUIRED AT EACH END OF ALL SHEARWALLS AND ALL END STUDS SHALL RECEIVE PANEL EDGE NAILING.
- 6 ALL EXTERIOR WALLS SHALL BE SW6, UNLESS NOTED OTHERWISE.
- 7 NAILS SHALL NOT BE SPACED LESS THAN 3/8" FROM EDGES OF SHEATHING. SHEATHING NAILS SHALL BE DRIVEN SO THEIR HEADS ARE FLUSH WITH SHEATHING (NOT COUNTERSUNK).
- 8 MP4s INSTALLED OVER SHEATHING WITH 8d (0.131"Ø x 2-1/2") NAILS MAY BE SUBSTITUTED FOR MPA1s AT CONTRACTORS OPTION.

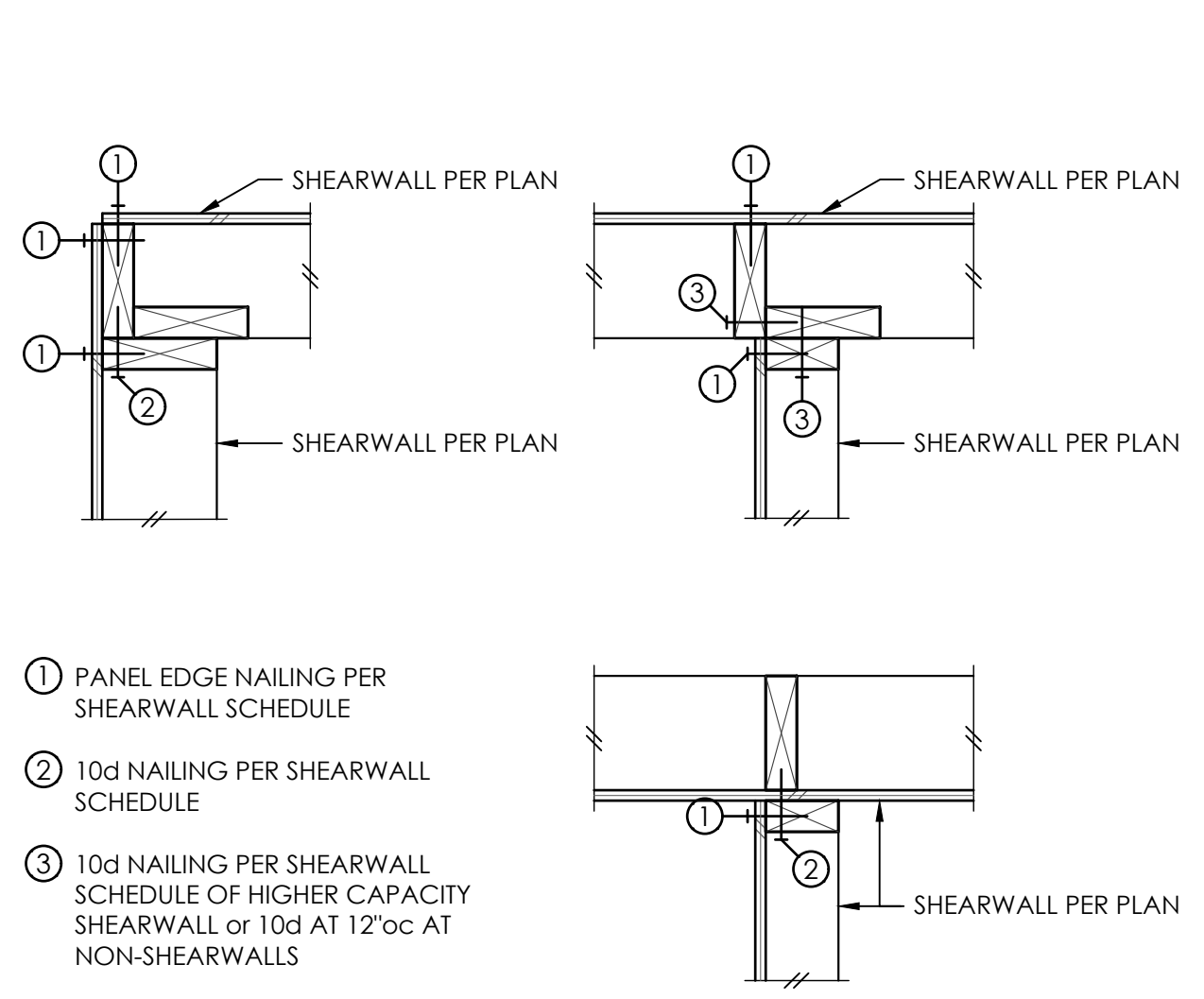

SCALE 1-1/2" = 1'-0"  
**TYPICAL SHEARWALL INTERSECTIONS**

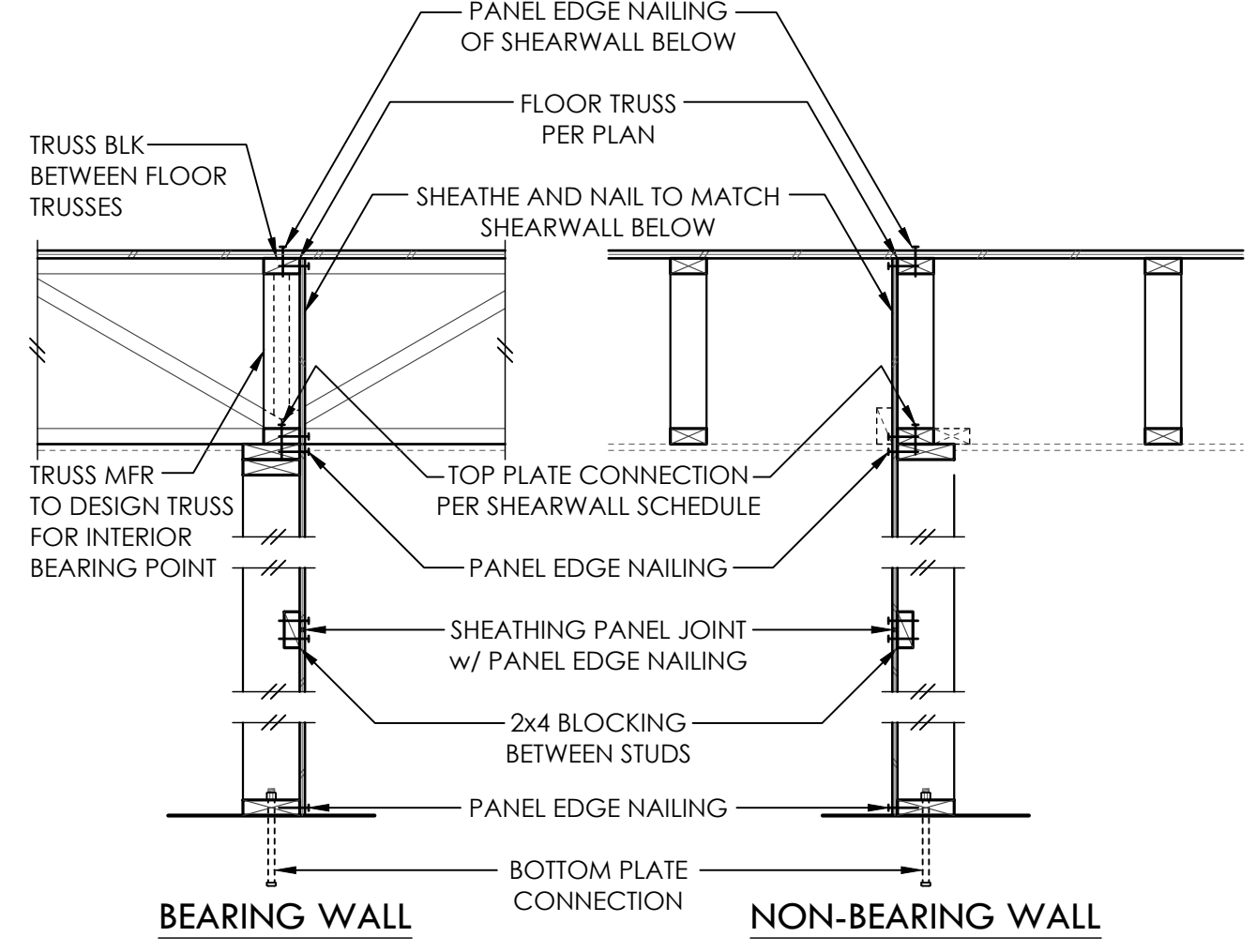

**NOTE:**  
SEE SHEARWALL SCHEDULE FOR ALL NAILING AND CONNECTIONS, NOT OTHERWISE NOTED

**TYPICAL SHEARWALL CONSTRUCTION**

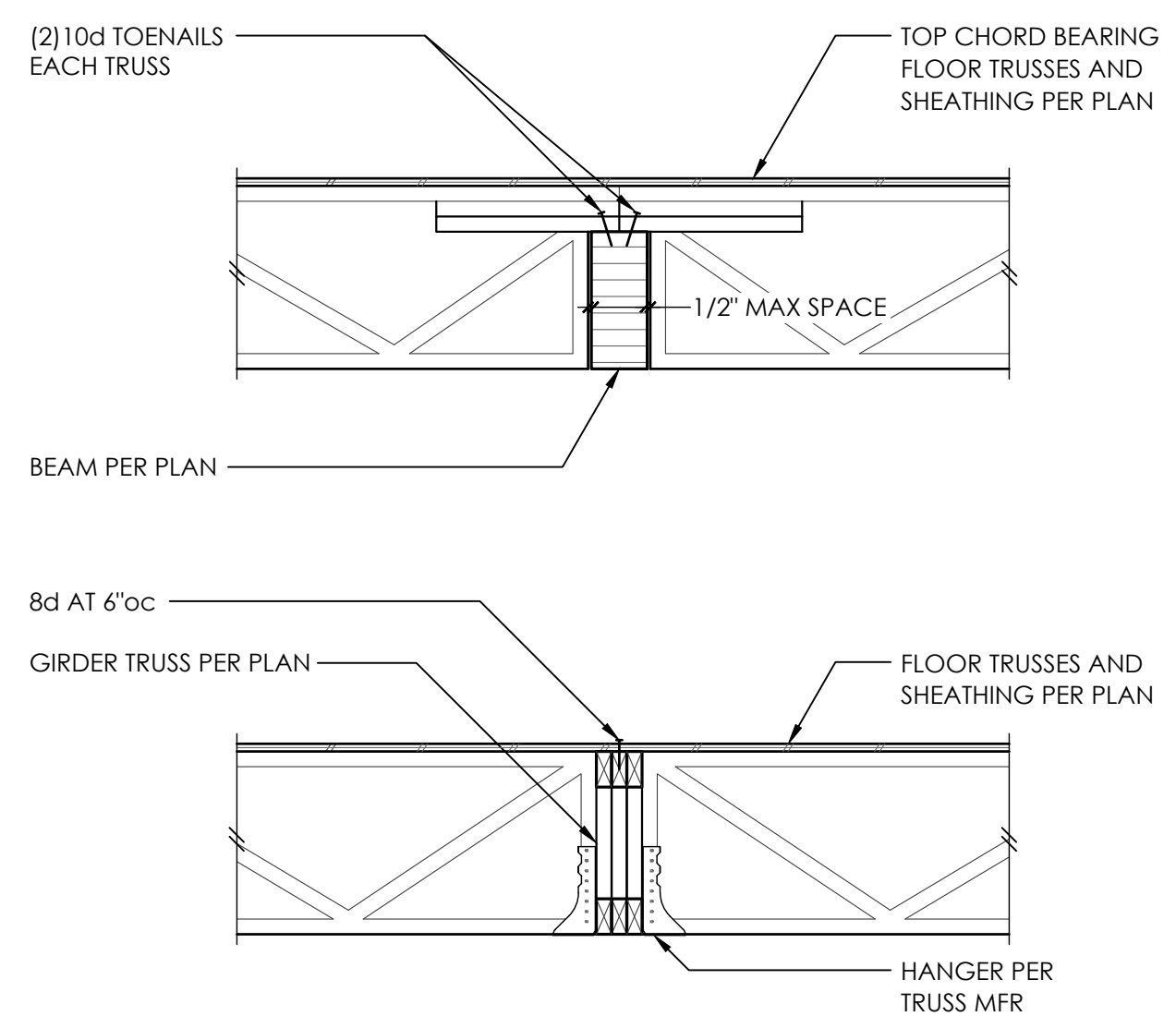
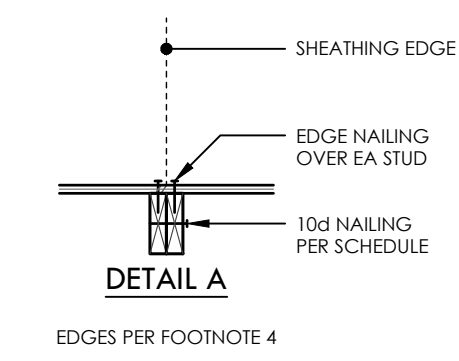

**5 TYPICAL BOTTOM FLUSH BEAM AND GIRDER TRUSS**

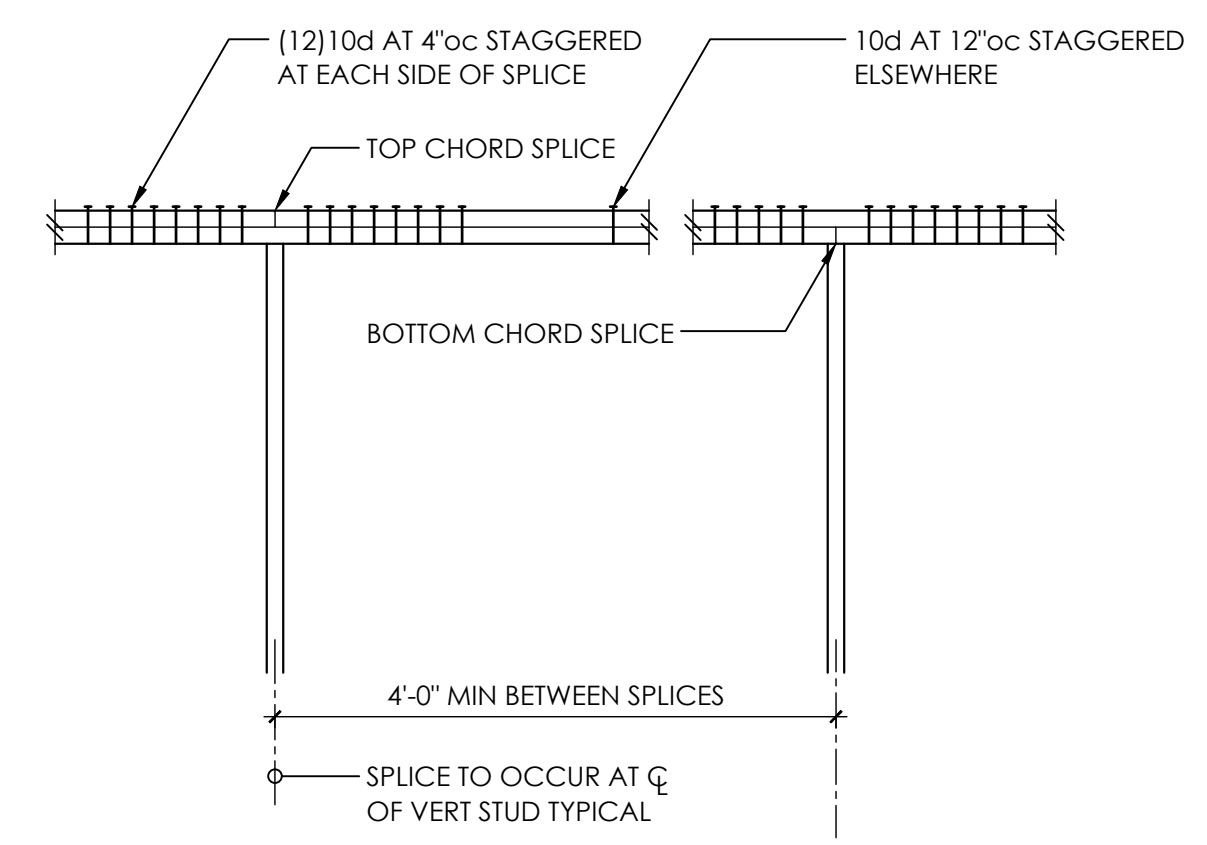

- NOTE:**
- NAILING AT TOP PLATE SPLICES MAY BE ELIMINATED w/ RS16 x 30"
  - WHERE VERTICAL PENETRATIONS THRU PLATE EXCEED 1" FOR A 4x WALL OR 3" FOR A 6x WALL - PROVIDE RS16 x 30" AT TOP PLATE
  - MINIMUM EDGE DISTANCE FOR VERTICAL PENETRATIONS THRU TOP PLATE IS 1-1/4"

**TYPICAL TOP PLATE SPLICE**

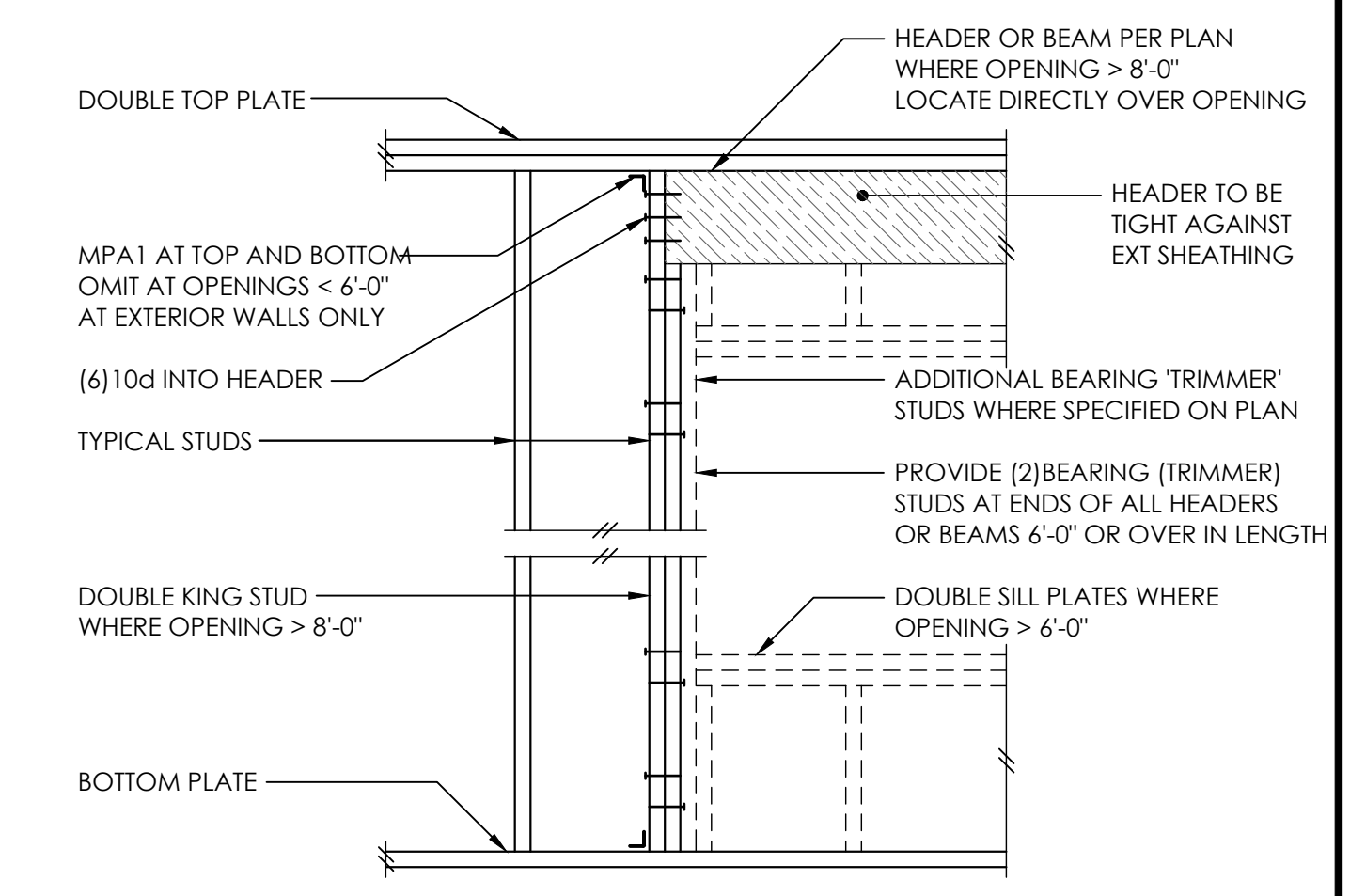

**TYPICAL HEADER SUPPORT**

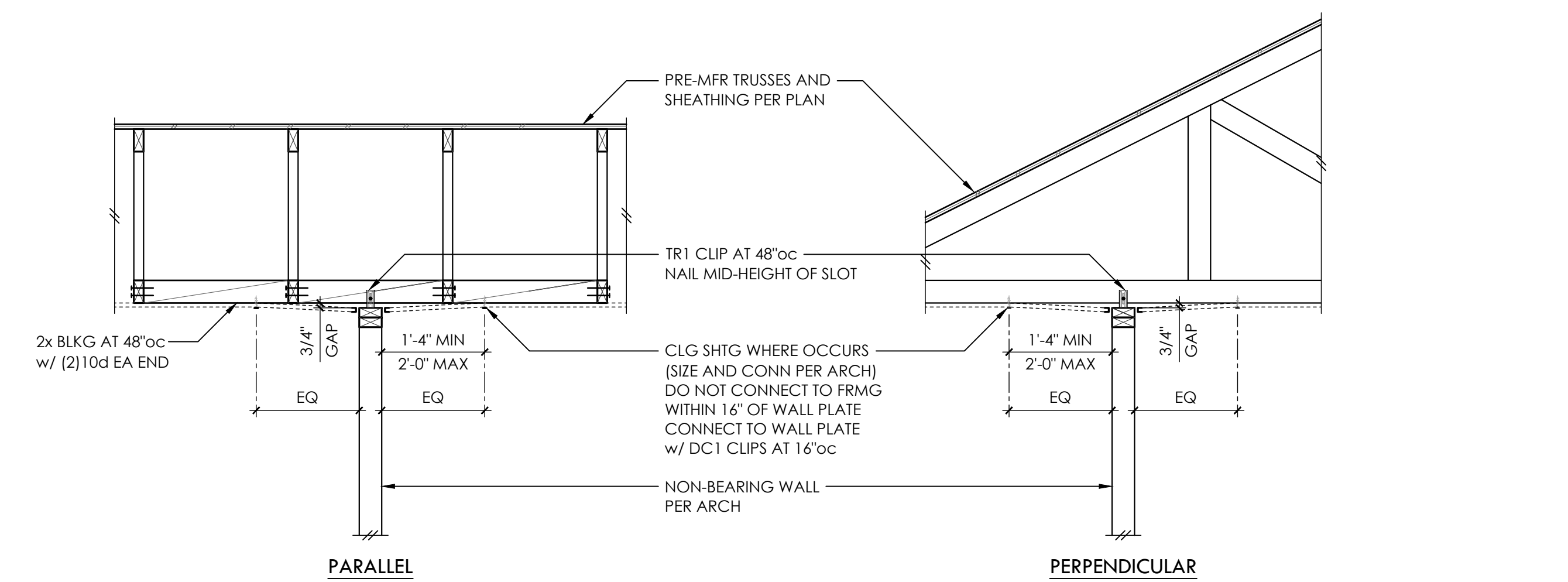

**TYPICAL NON-STRUCTURAL WALL TO ROOF TRUSSES**

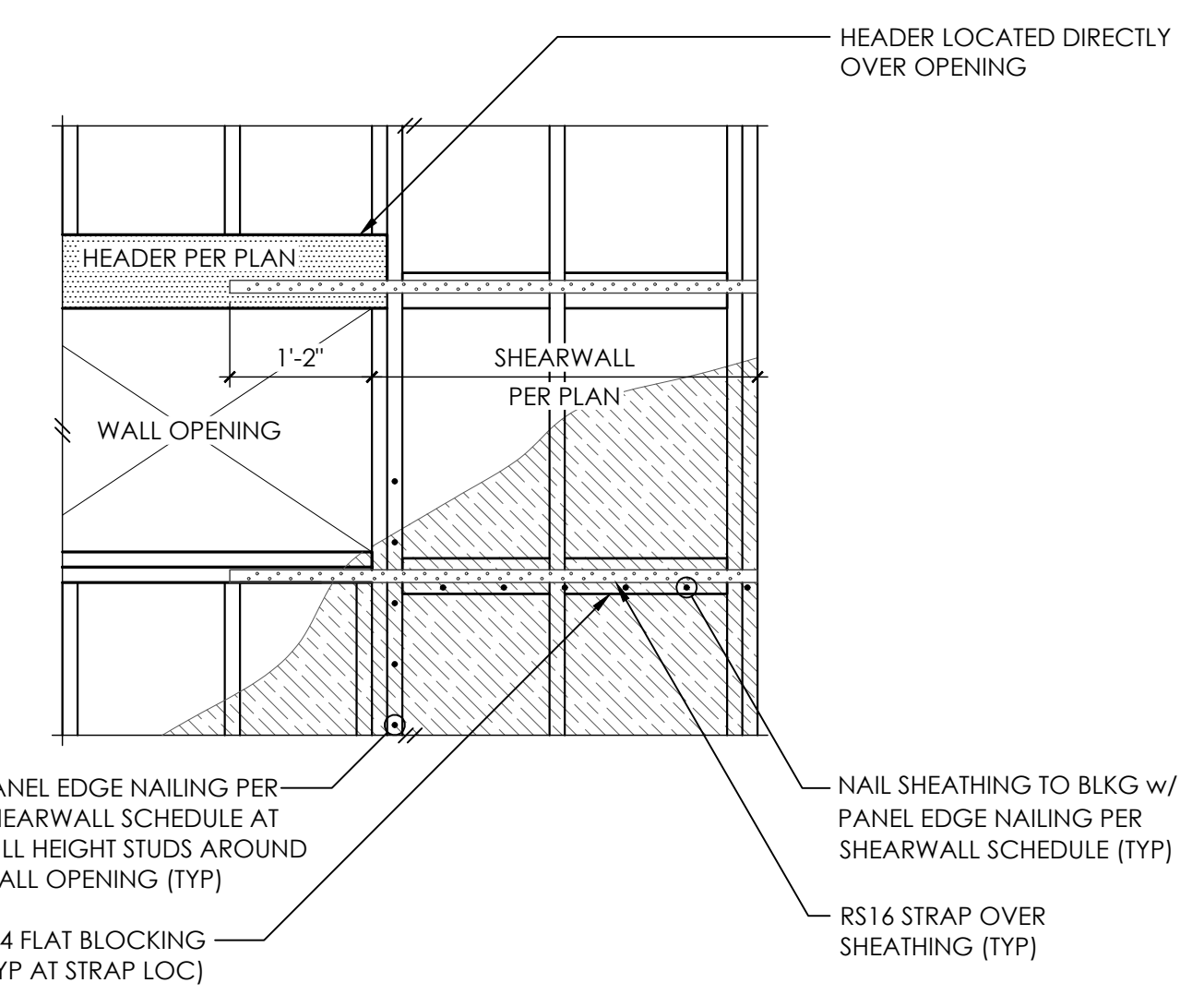

**11**

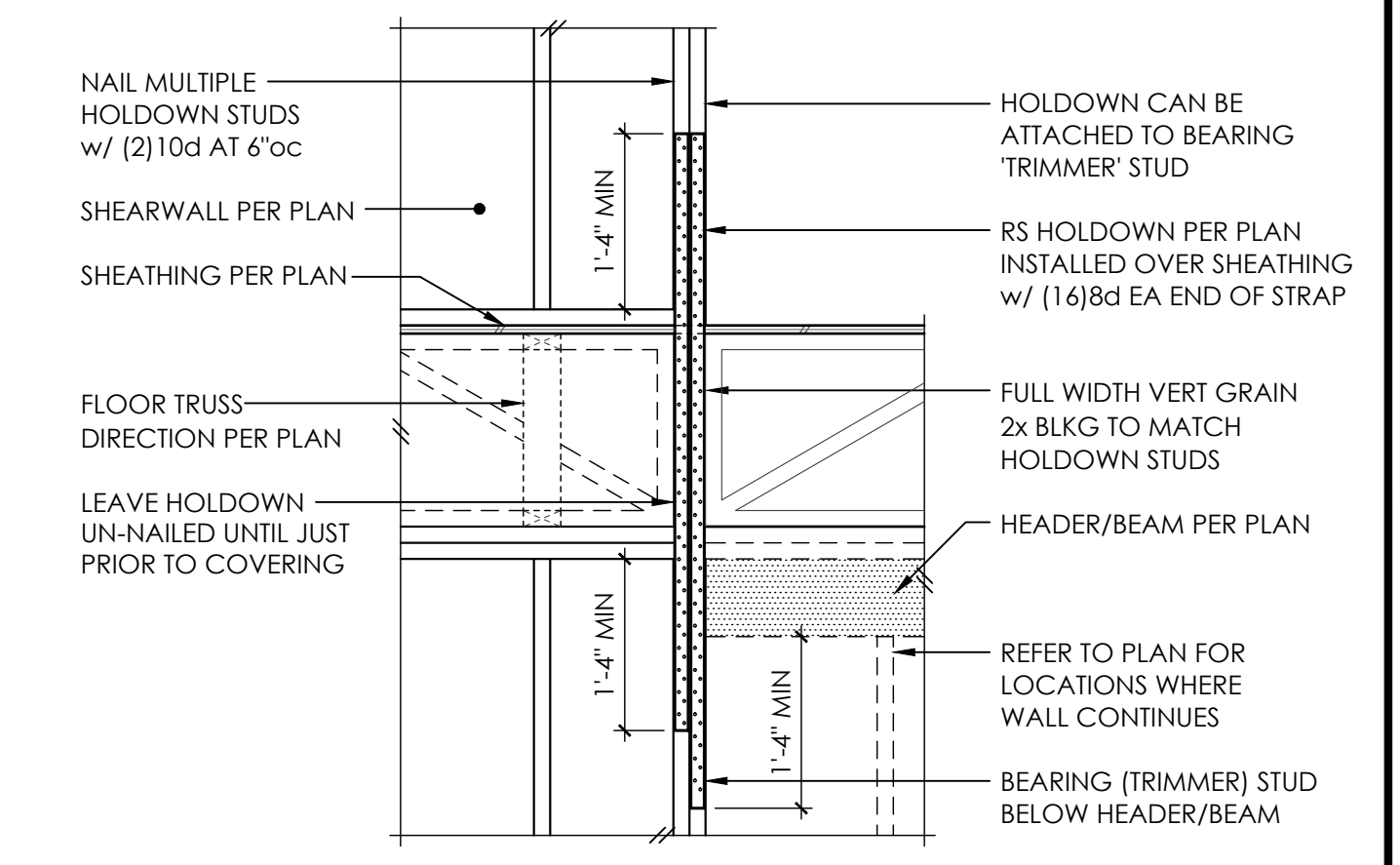

**TYPICAL RS16 HOLDDOWN**

**12**



**APPROVED**  
Plans Reviewed by **SAFEbuilt**  
For Building Code Compliance  
Reviewed By:  
**Bobby Thomas CBO, Plans Examiner,**  
Combination Inspector  
Date:  
**7/20/2023 REV 1**

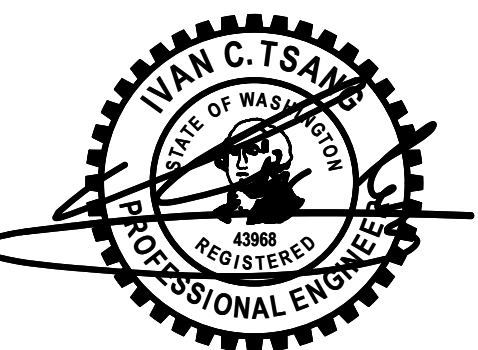

PROJECT NO 0135.2020.12.0306  
PROJECT MANAGER RAF  
DRAWN JSD  
ENGINEER NATE MOORE  
206.602.9537  
NATEM@MALSAM-TSANG.COM

REV	DESCRIPTION	DATE
	PERMIT SET	7.6.23

ARCH MAINVUE HOMES  
425.646.4022

**WOOD FRAMING  
DETAILS**

**S4.1**  
SCALE - NTS

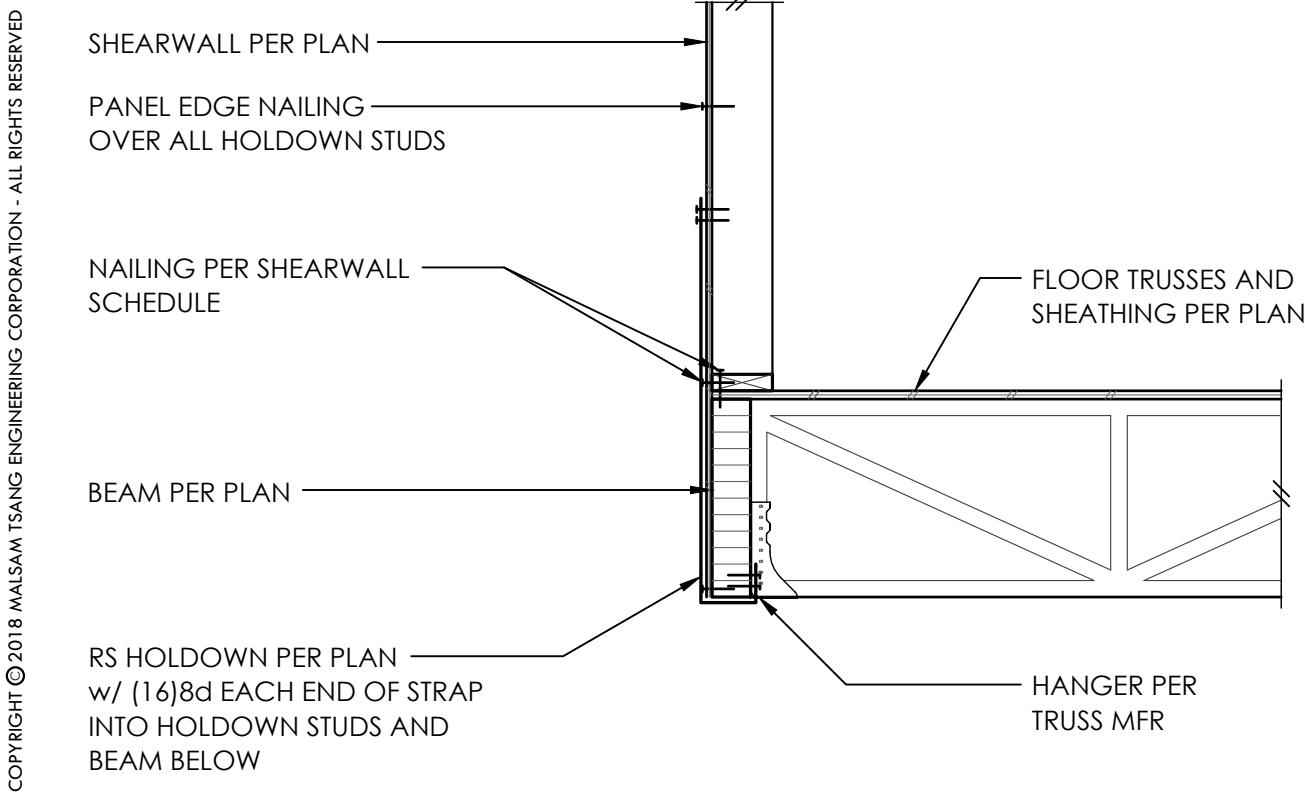

1

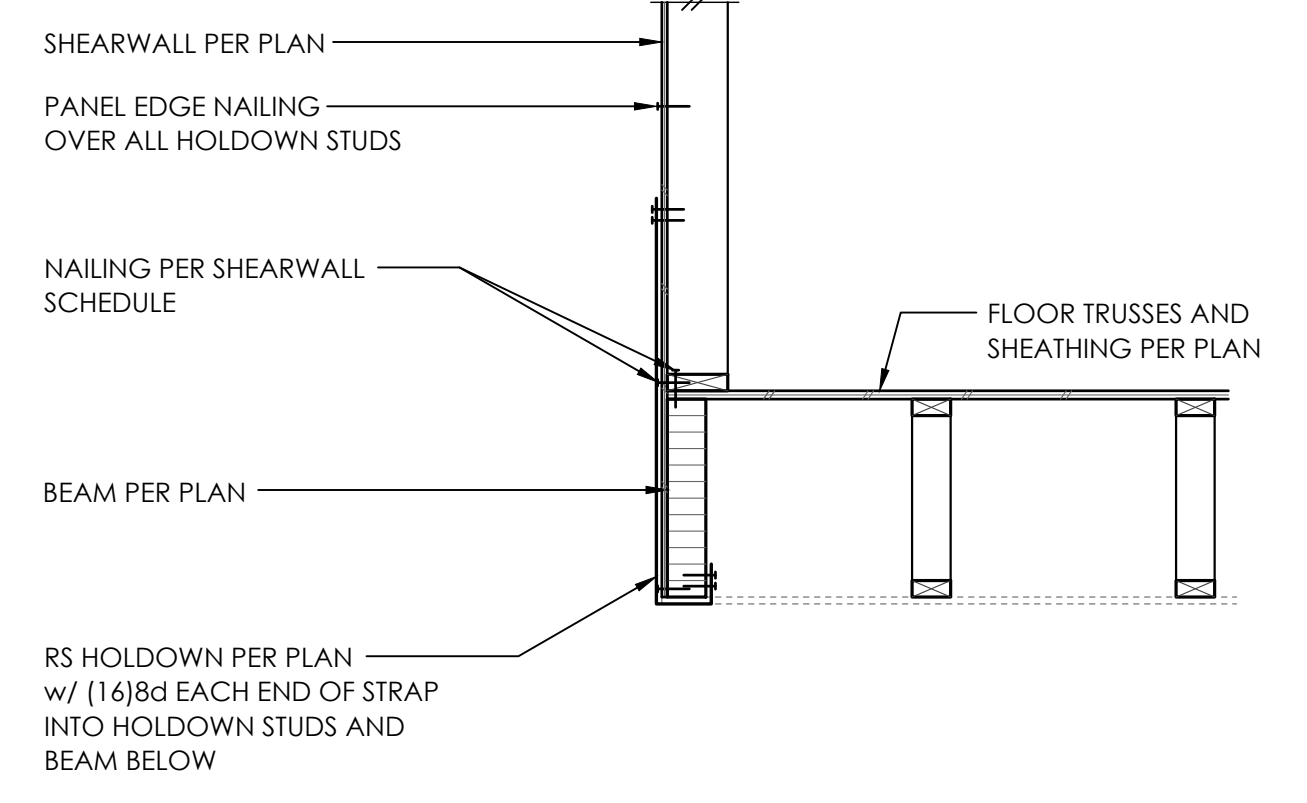

2

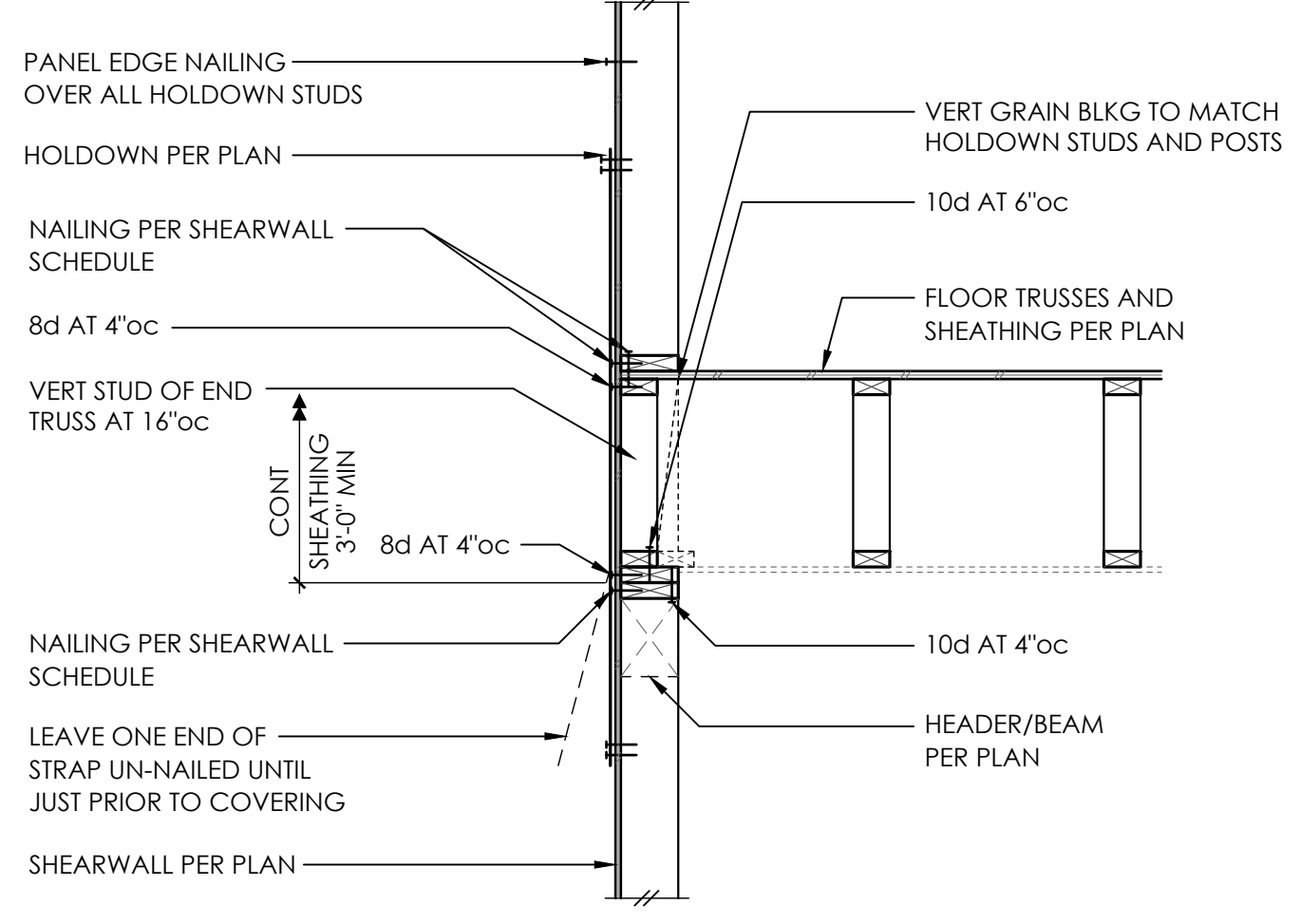

3

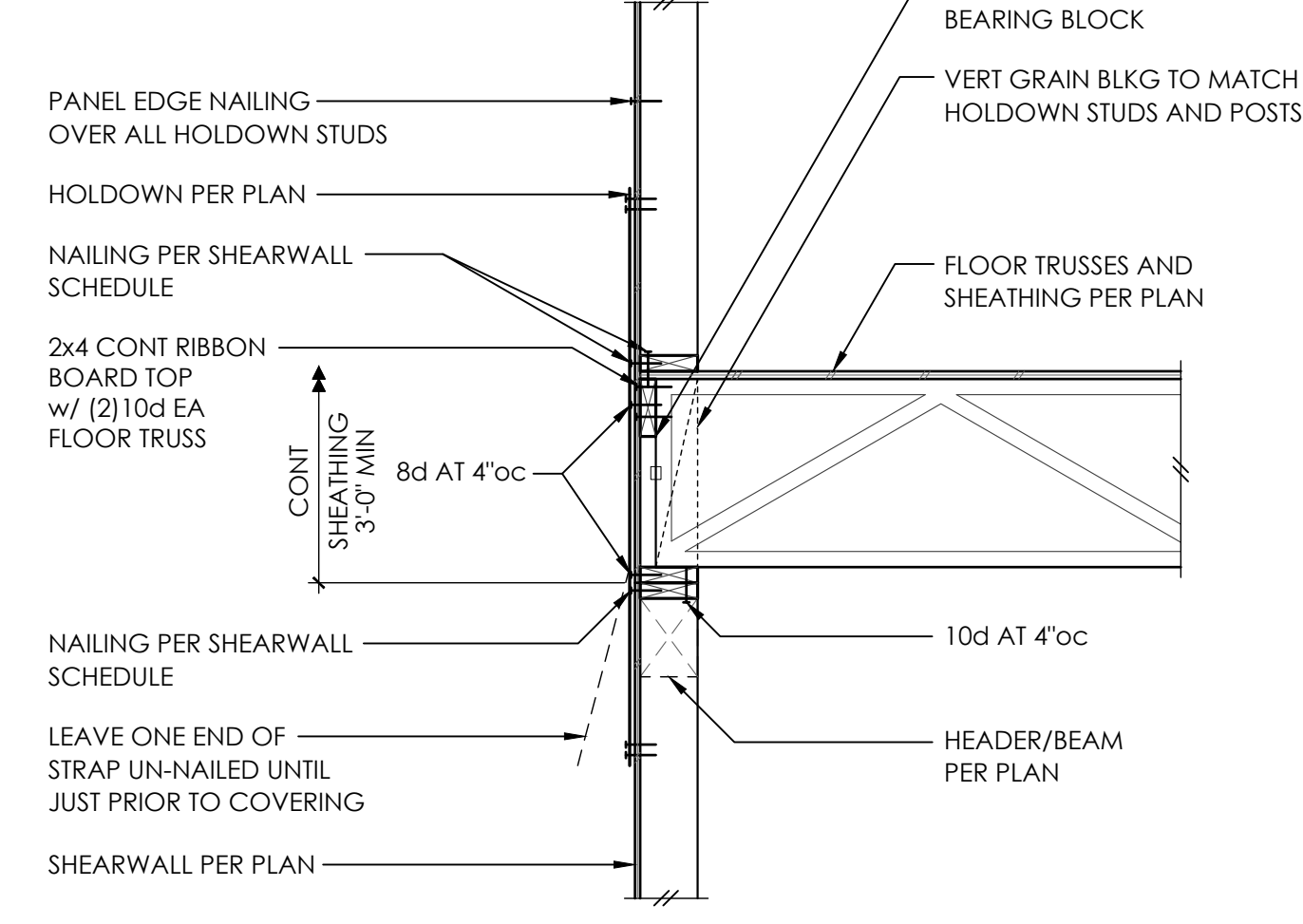

4

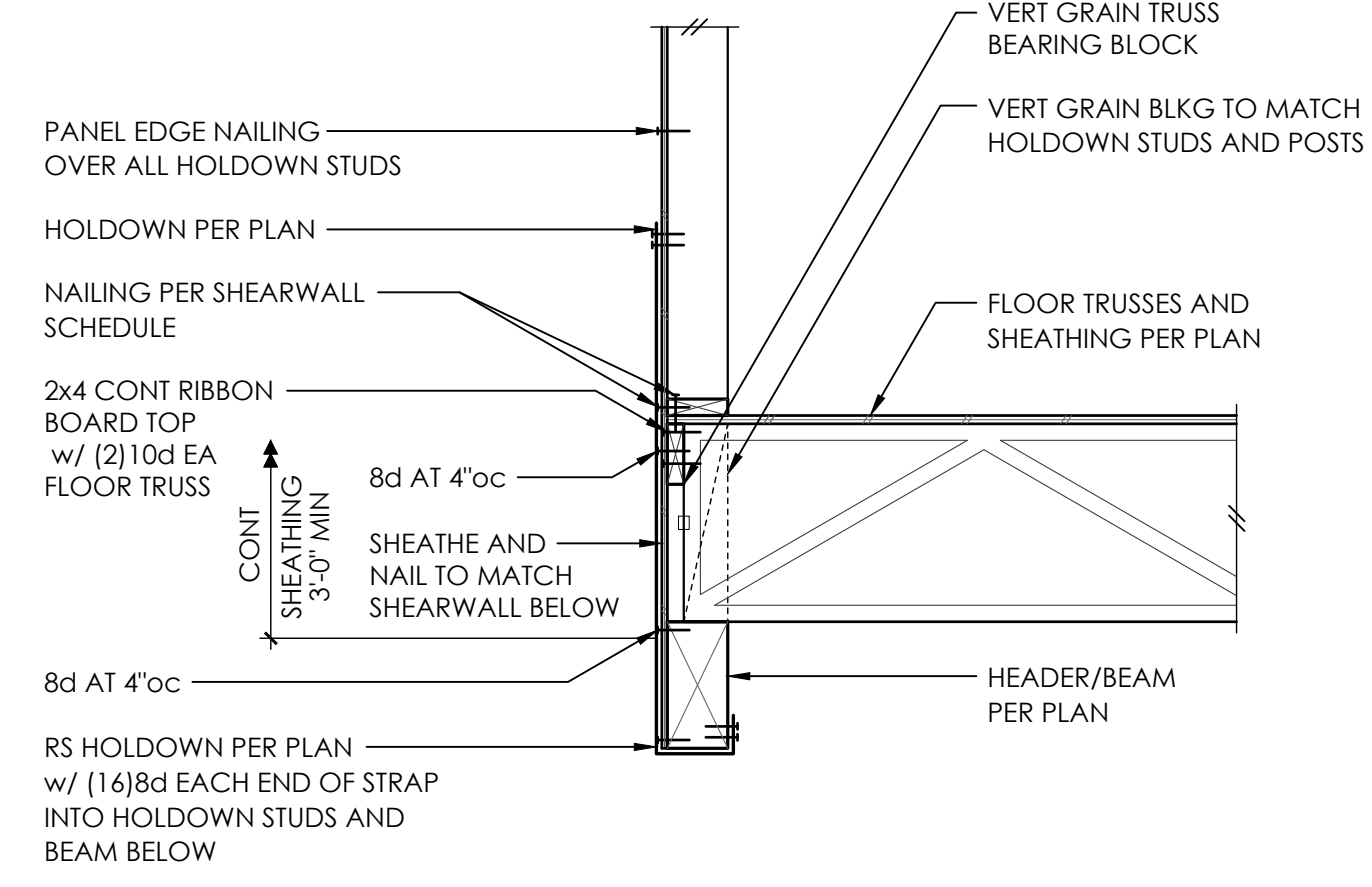

5

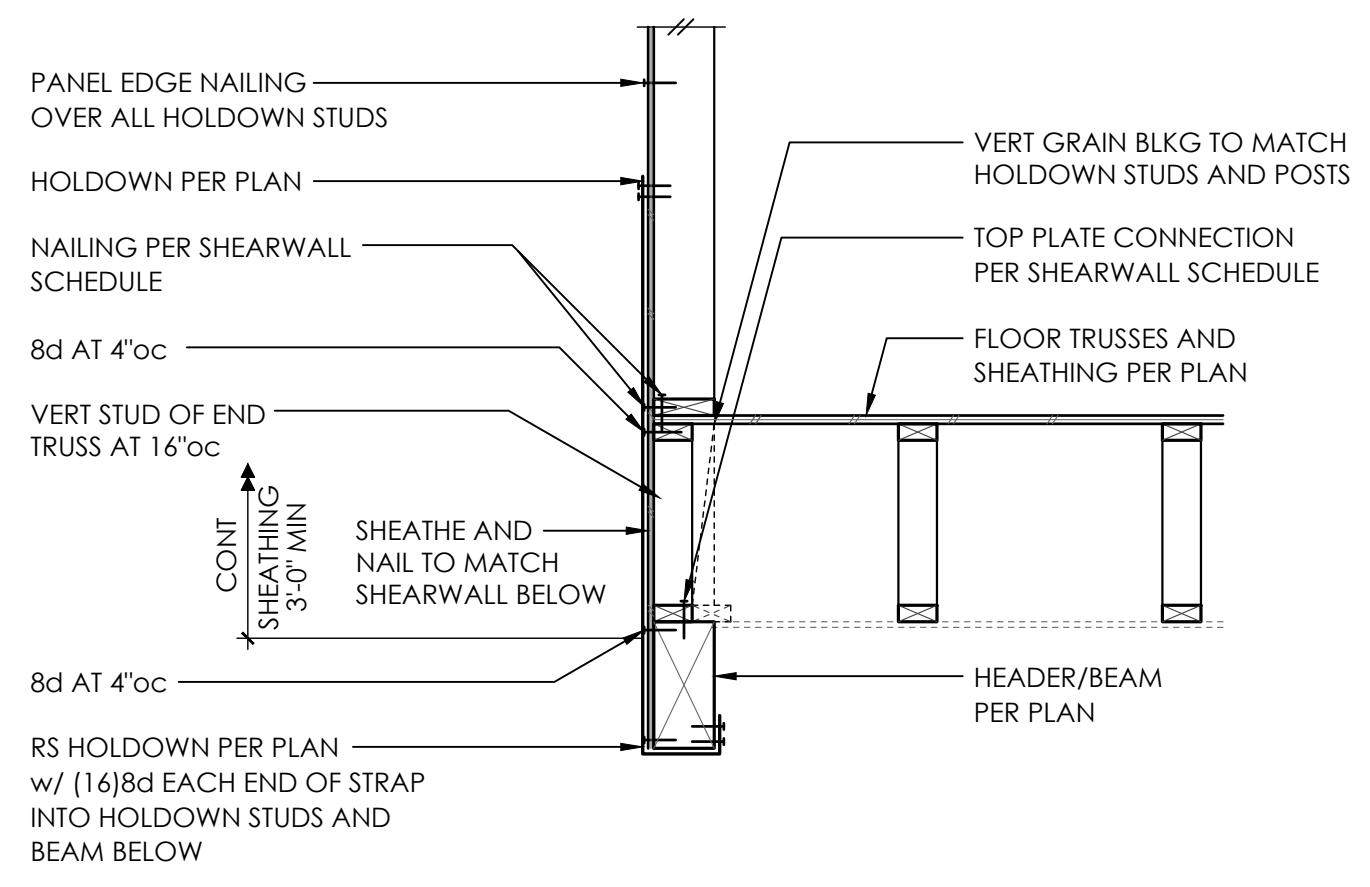

6

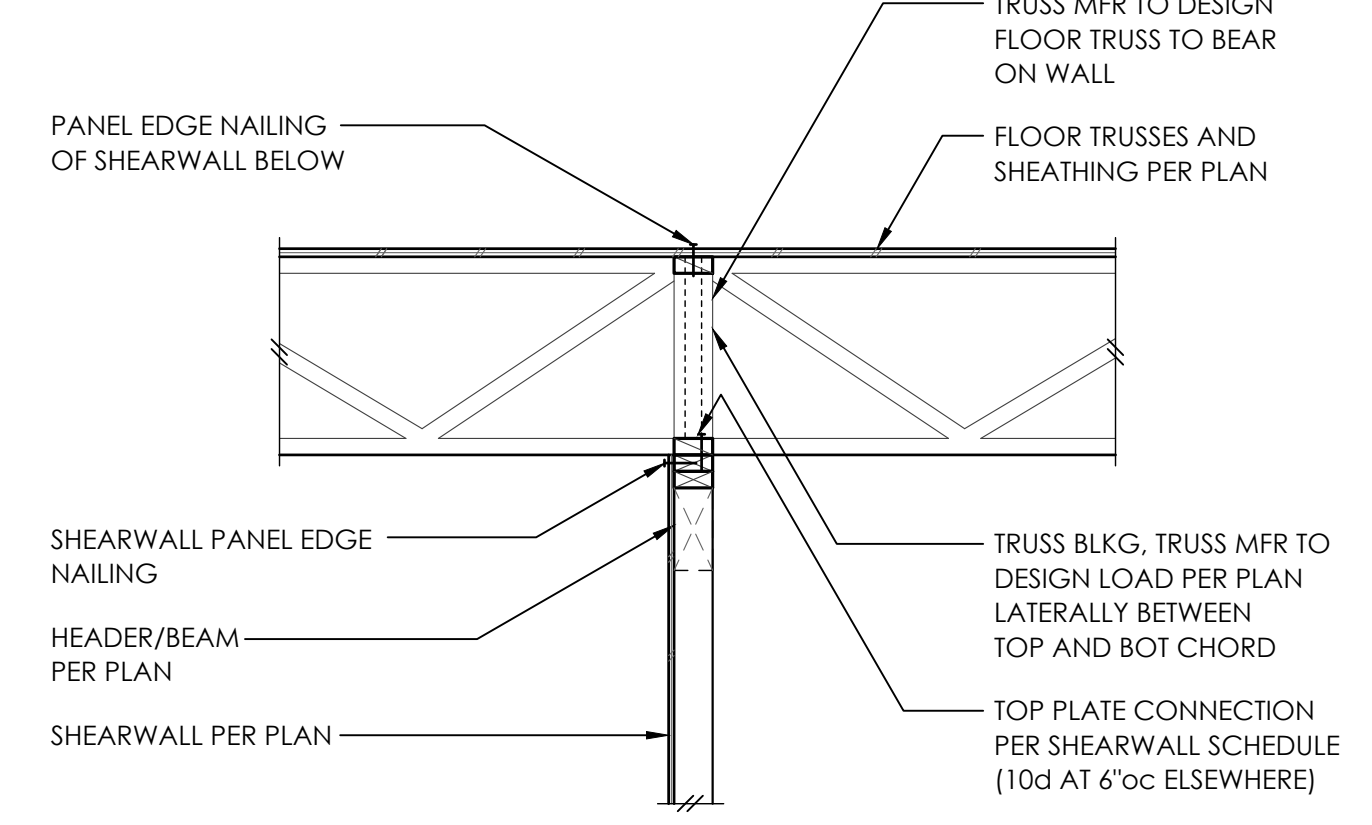

7

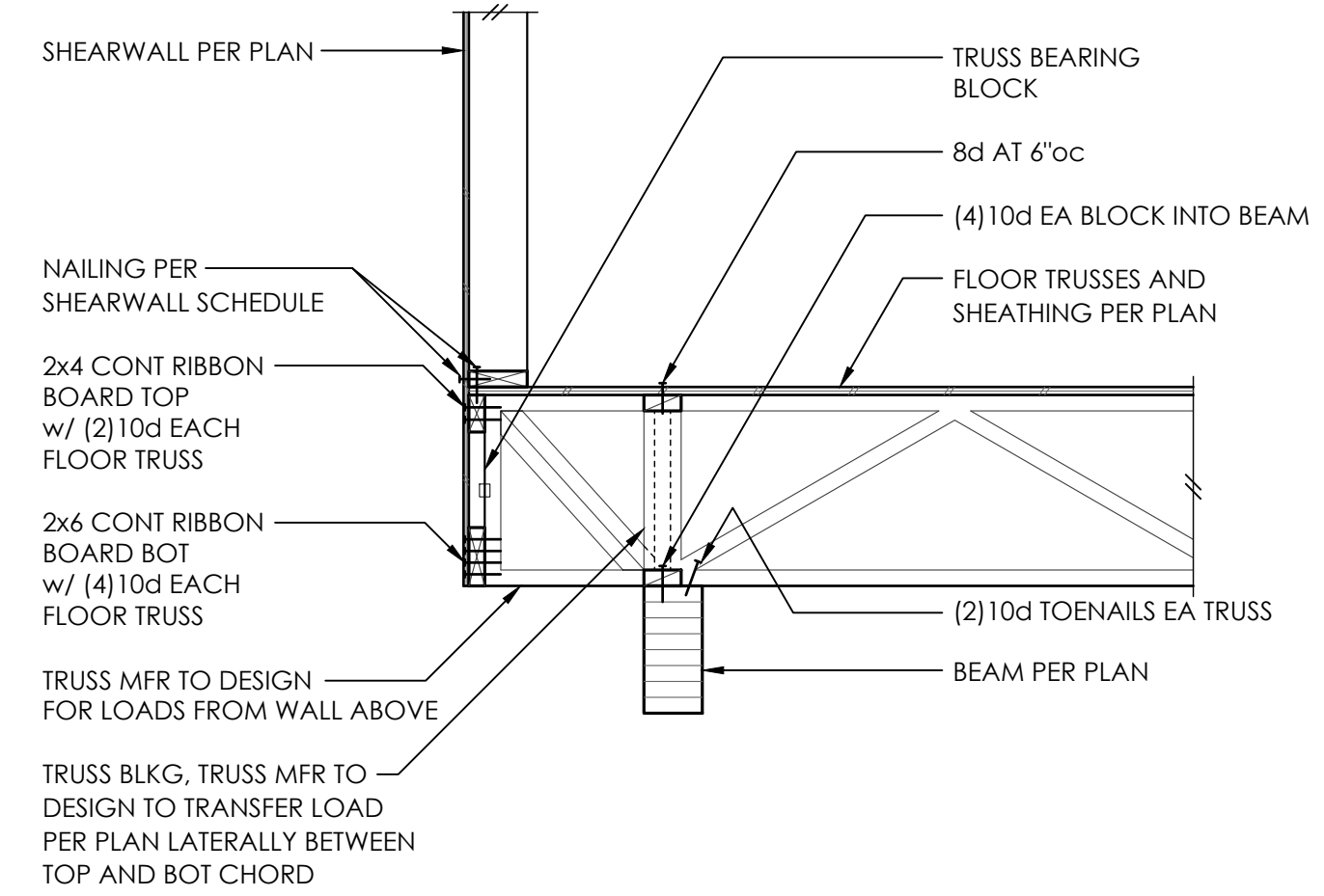

8

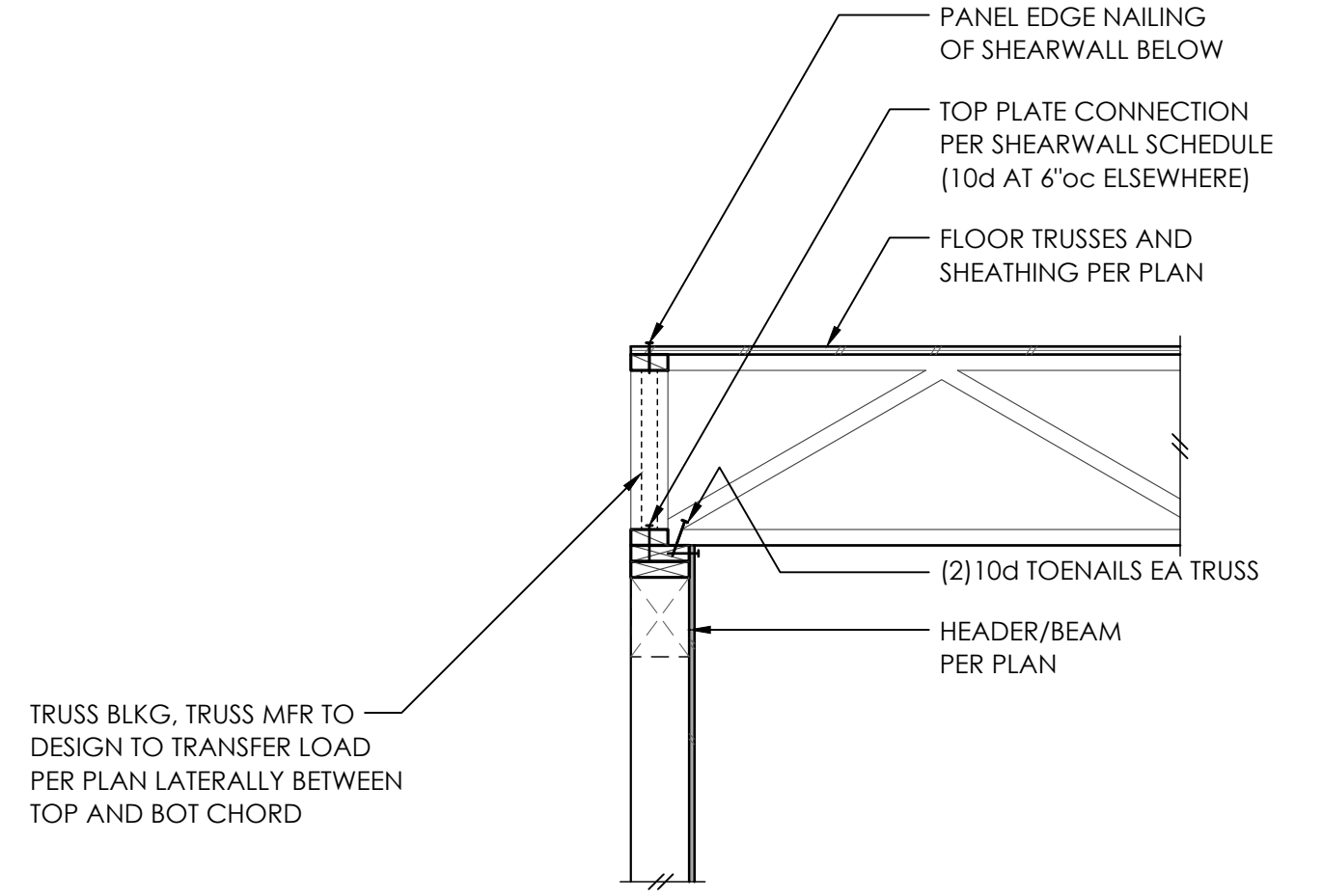

9

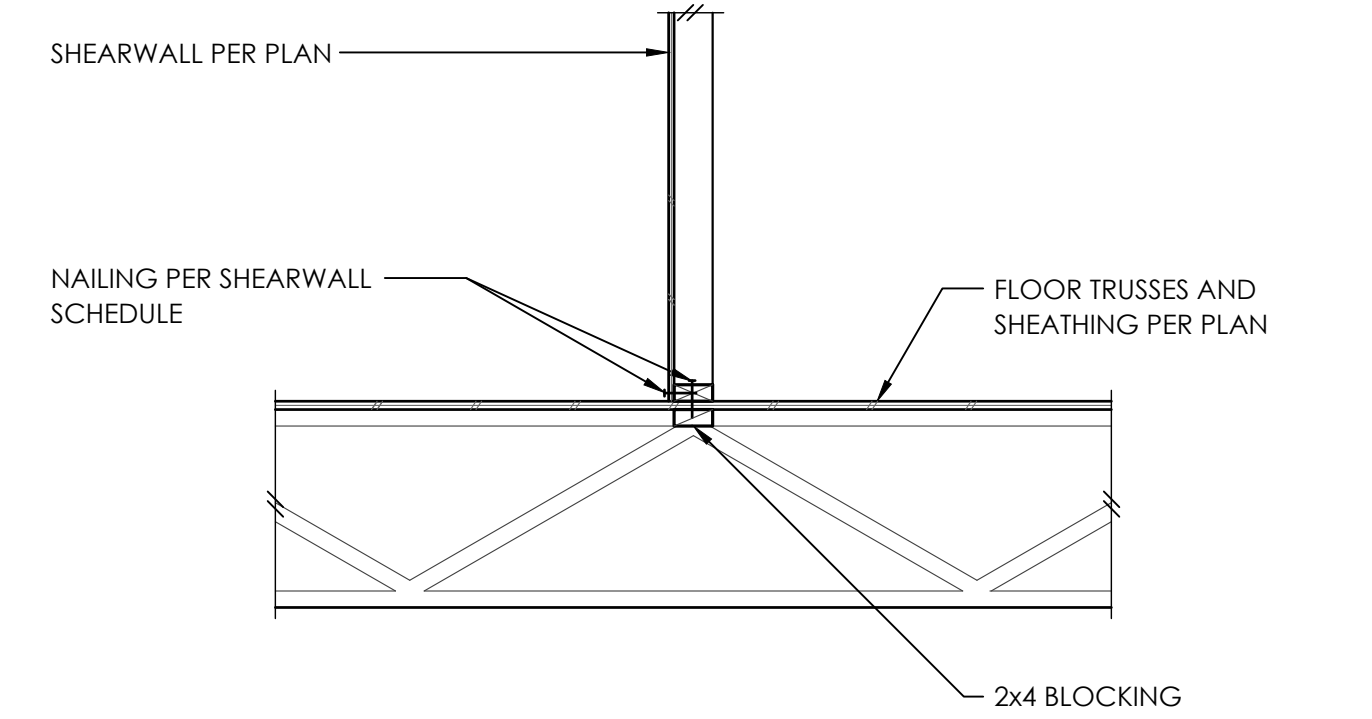

10

Plotted by: lomatthod  
Printed Date: Jul 06, 2023 - 4:43pm

11

12



**APPROVED**  
Plans Reviewed by **SAFEbuilt**  
WASHINGTON  
For Building Code Compliance  
Reviewed By:  
**Bobby Thomas CBO, Plans Examiner,**  
Combination Inspector  
Date:  
**7/20/2023 REV 1**

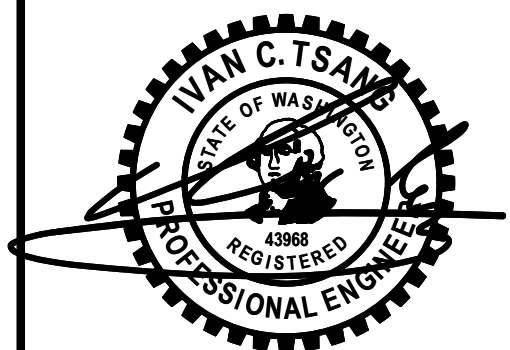

PROJECT NO 0135.2020.12.0306  
PROJECT MANAGER RAF  
DRAWN JSD  
ENGINEER NATE MOORE  
206.602.9537  
NATEM@MALSAM-TSANG.COM

REV	DESCRIPTION	DATE
PERMIT SET		7.6.23

ARCH MAINVUE HOMES  
425.646.4022

**WOOD FRAMING  
DETAILS**

**S4.2**  
SCALE - NTS

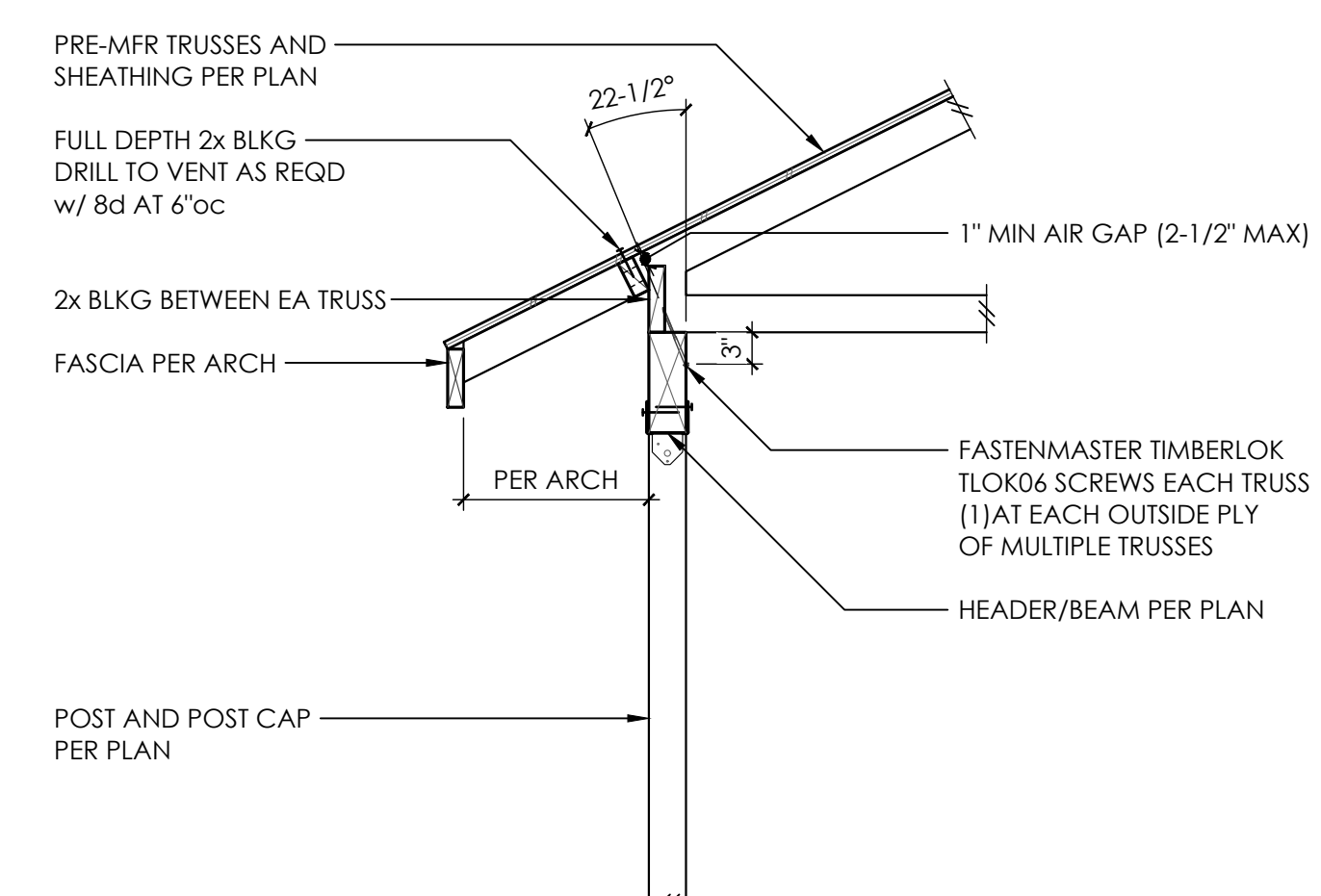
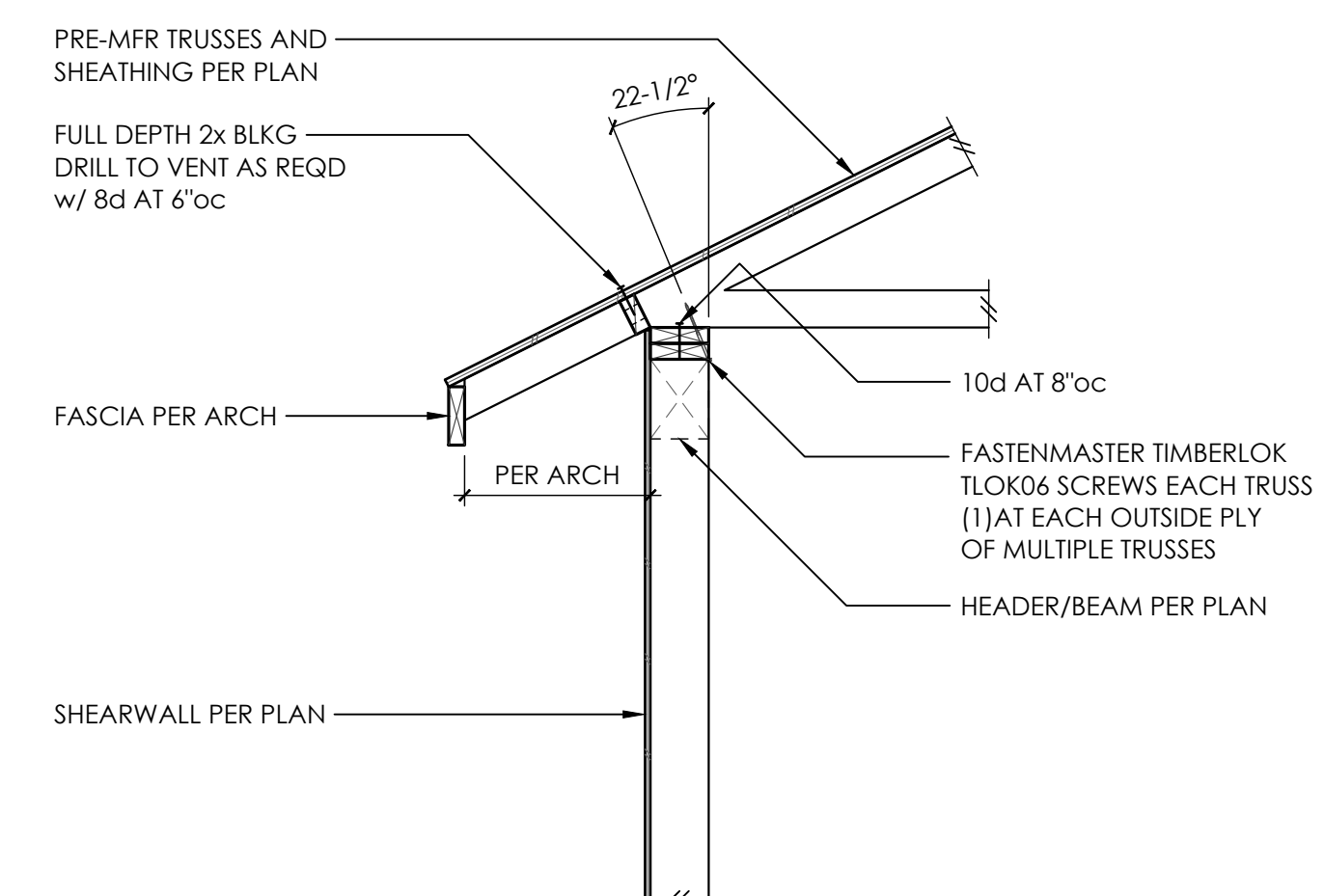
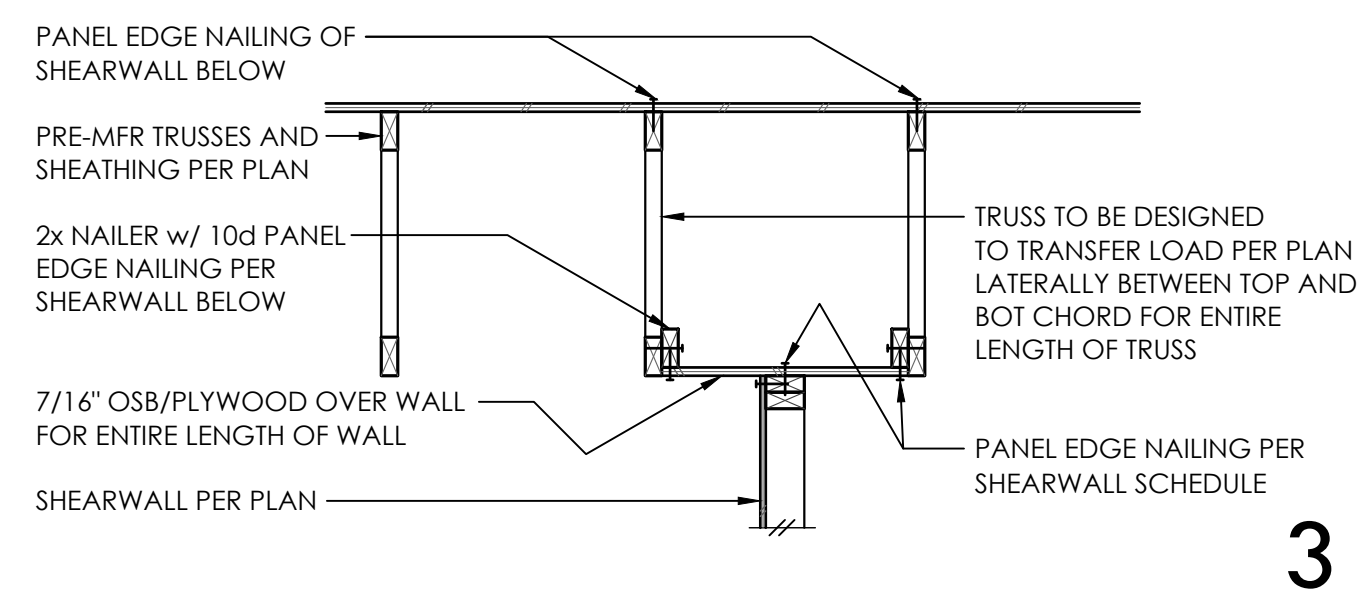
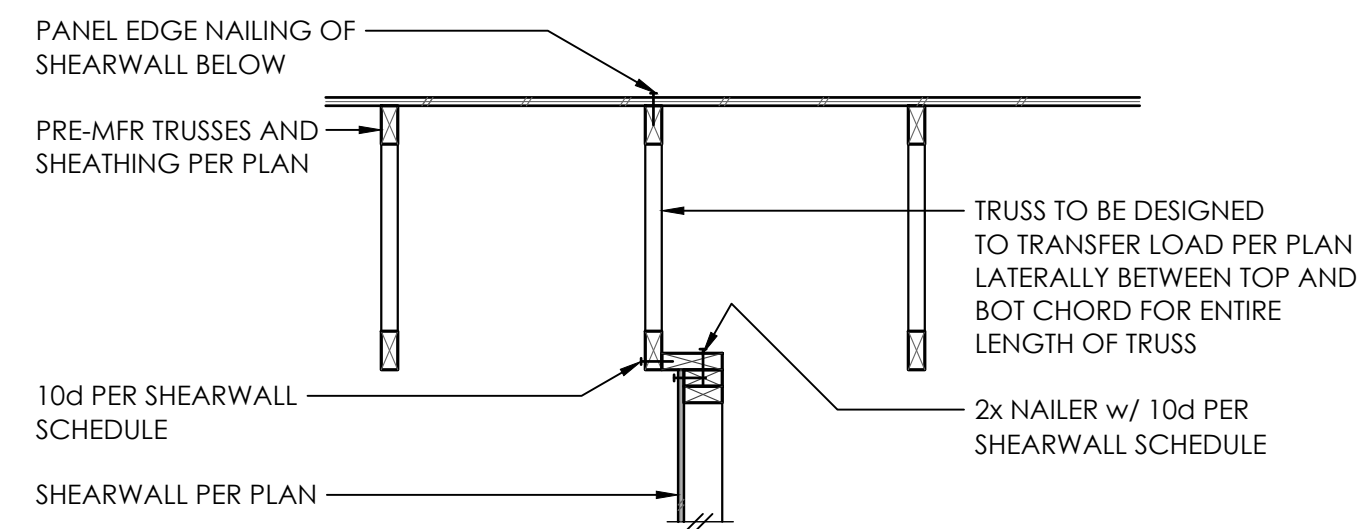

1

2

3

4

5

6

7

8

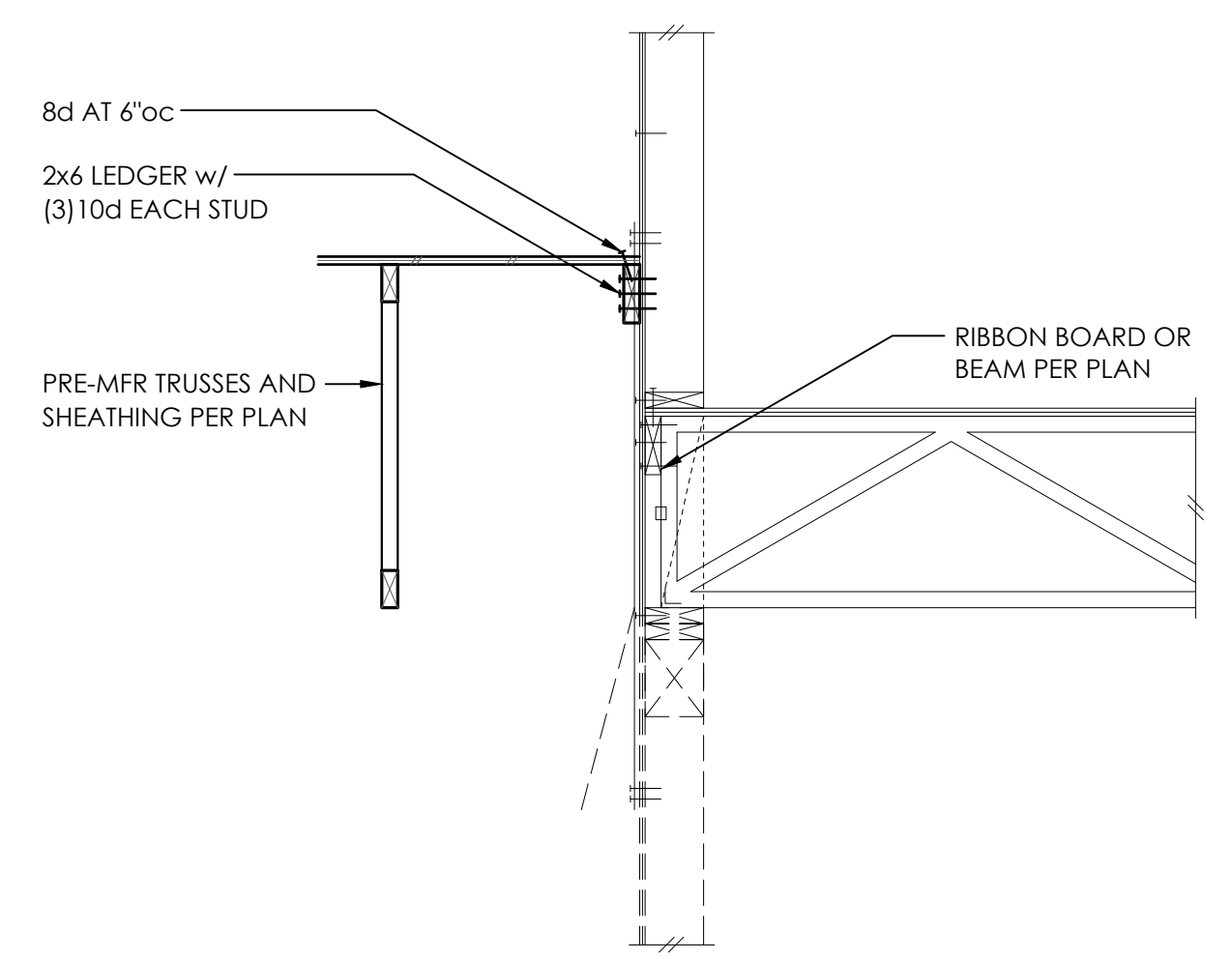
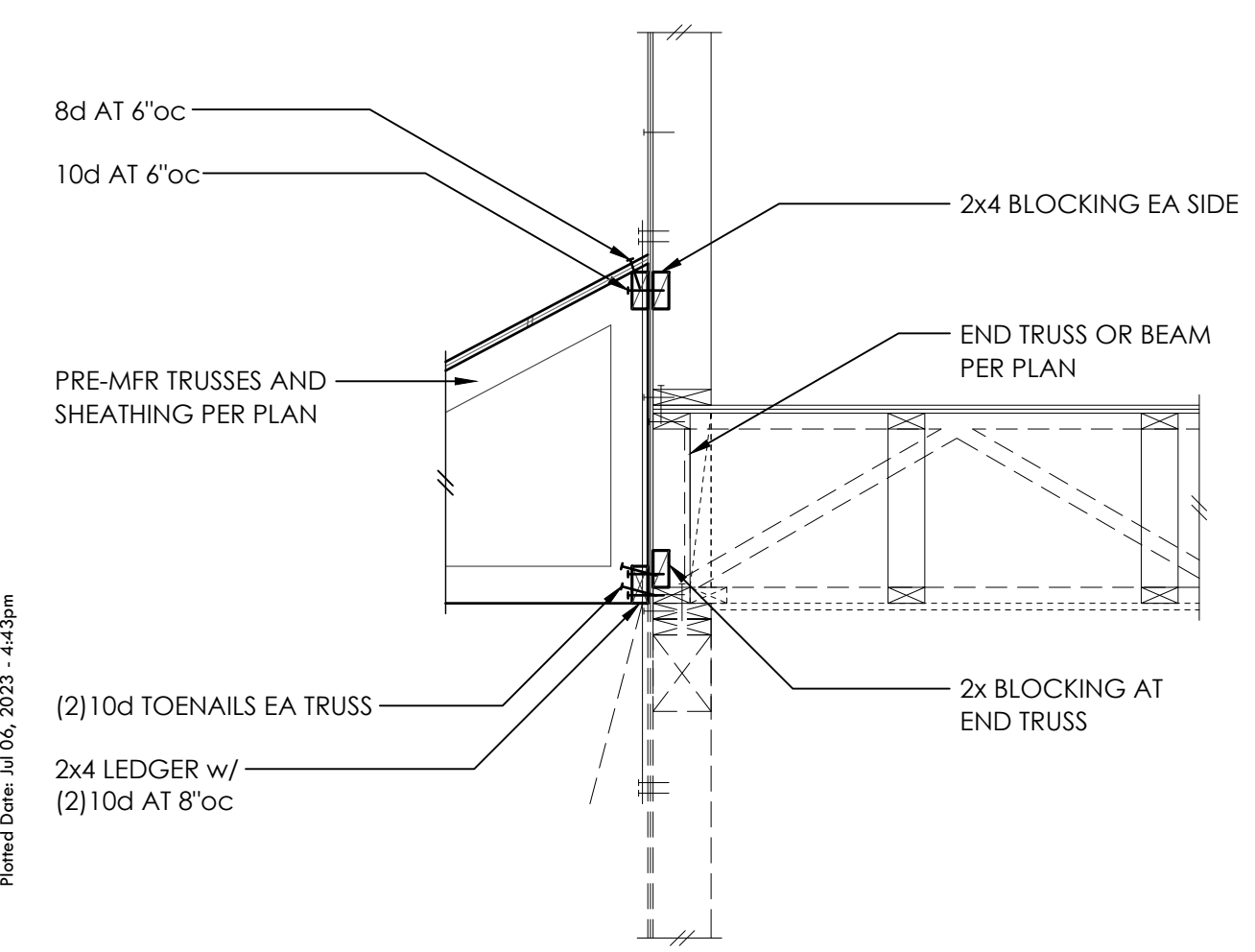

Plotted by: lromano  
Printed Date: Jul 06, 2023 - 4:43pm

9

10

11

12