

## FOOTING OPTION "A"

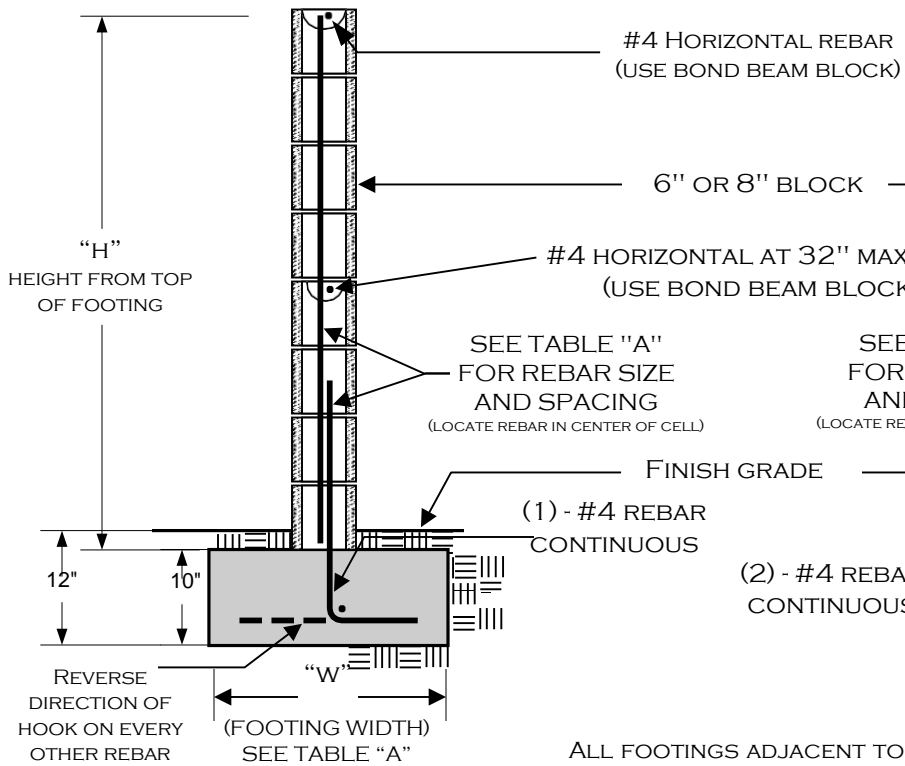

"H"	"W"	VERTICAL REINFORCEMENT
3'	17"	#4 @ 48" O.C.
4'	20"	#4 @ 48" O.C.
5'	23"	#4 @ 48" O.C.
6'	29"	#4 @ 24" O.C.

ALL FOOTINGS ADJACENT TO SLOPES TO BE AT LEAST 5' TO DAYLIGHT AS SHOWN BELOW.

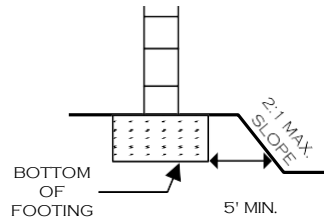

## FOOTING OPTION "B"

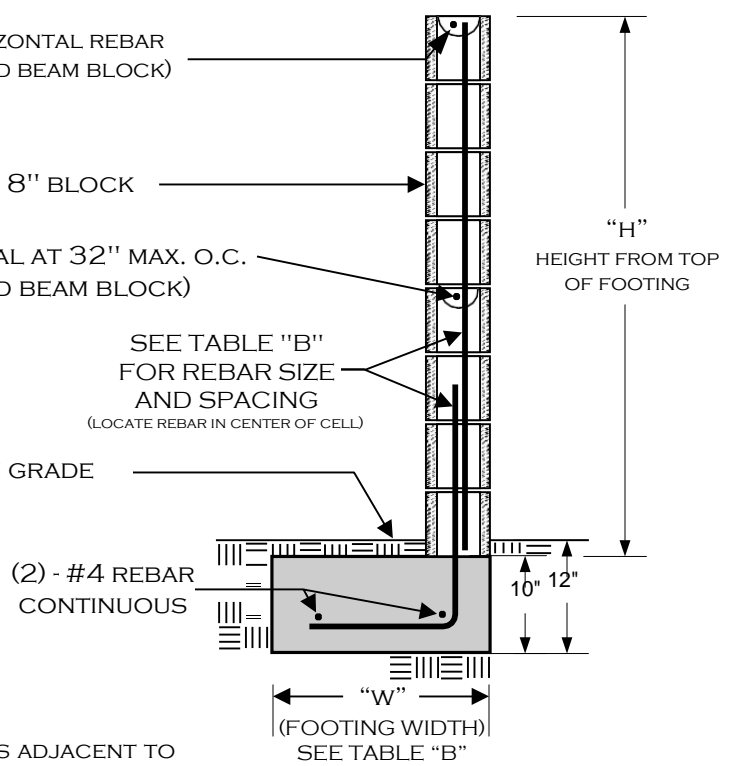

"H"	"W"	VERTICAL REINFORCEMENT
3'	19"	#4 @ 48" O.C.
4'	22"	#4 @ 48" O.C.
5'	29"	#4 @ 48" O.C.
6'	34"	#4 @ 24" O.C.

### NOTES:

- 1) THIS DESIGN DOES **NOT** ALLOW GRADE DIFFERENTIALS OF MORE THAN 6" ON OPPOSING SIDES OF THE WALL. THIS IS **NOT** A RETAINING WALL.
- 2) FENCE HEIGHTS ARE REGULATED — CONSULT ZONING REGULATIONS BEFORE BEGINNING CONSTRUCTION.
- 3) NO WATER COURSE OR NATURAL DRAINAGE SHALL BE OBSTRUCTED.
- 4) GROUT **ONLY** THE CELLS CONTAINING REBAR. THIS WALL IS **NOT** DESIGNED FOR ALL CELLS TO BE GROUTED.
- 5) ALL REBAR TO BE ASTM SPEC. A615, GRADE 40 MINIMUM.
- 6) ALL REBAR LAP SPLICES TO BE 24" MINIMUM.
- 7) ALL MASONRY UNITS TO BE ASTM C-90 GRADE N.
- 8) REBAR TO BE CENTERED IN MASONRY CELLS.

CHECK WITH THE BUILDING DEPARTMENT TO VERIFY IF A BUILDING PERMIT IS REQUIRED.

WHEN A PERMIT IS REQUIRED, THE FOLLOWING INSPECTIONS ARE REQUIRED:

- 1) **FOOTING**; EXCAVATION TRENCH CLEAN WITH STEEL IN PLACE AND SUPPORTED 3" ABOVE AND AWAY FROM THE SURROUNDING EARTH/DIRT.
- 2) **REBAR/PRE-GROUT**; BOND BEAM REBAR AND VERTICAL REBAR IN PLACE - INSPECTION PRIOR TO PLACING GROUT.
- 3) **FINAL**; AFTER GROUT IS PLACED - PRIOR TO ANY DECORATIVE CAP PLACEMENT.

\*SEE PAGE 2 FOR ADDITIONAL INFORMATION\*

### DISCLAIMER:

ALTERNATE DESIGNS MAY BE POSSIBLE WHEN PROVIDED WITH AN ENGINEERED ANALYSIS. USE OF THIS STANDARD DESIGN IS AT THE USER'S RISK AND CARRIES NO IMPLIED OR INFERRED GUARANTEE AGAINST FAILURE OR DEFECTS.

WESTERN RIVERSIDE COUNTY CODE UNIFORMITY PROGRAM			
	<b>CITY OF DESERT HOT SPRINGS</b>		
	<b>BUILDING DEPARTMENT</b>		
FREESTANDING BLOCK WALL			
(760) 329-6411		65950 PIERSON BLVD. DESERT HOT SPRINGS, CA 92240	
		11/08/17	RCLMNGDNWALLFNL.VSD
		PAGE 1 OF 2	

# REBAR PLACEMENT ILLUSTRATION

FOOTING OPTION B

(TYPICAL)  
ALL REBAR SPLICES  
24" MIN. OVERLAP

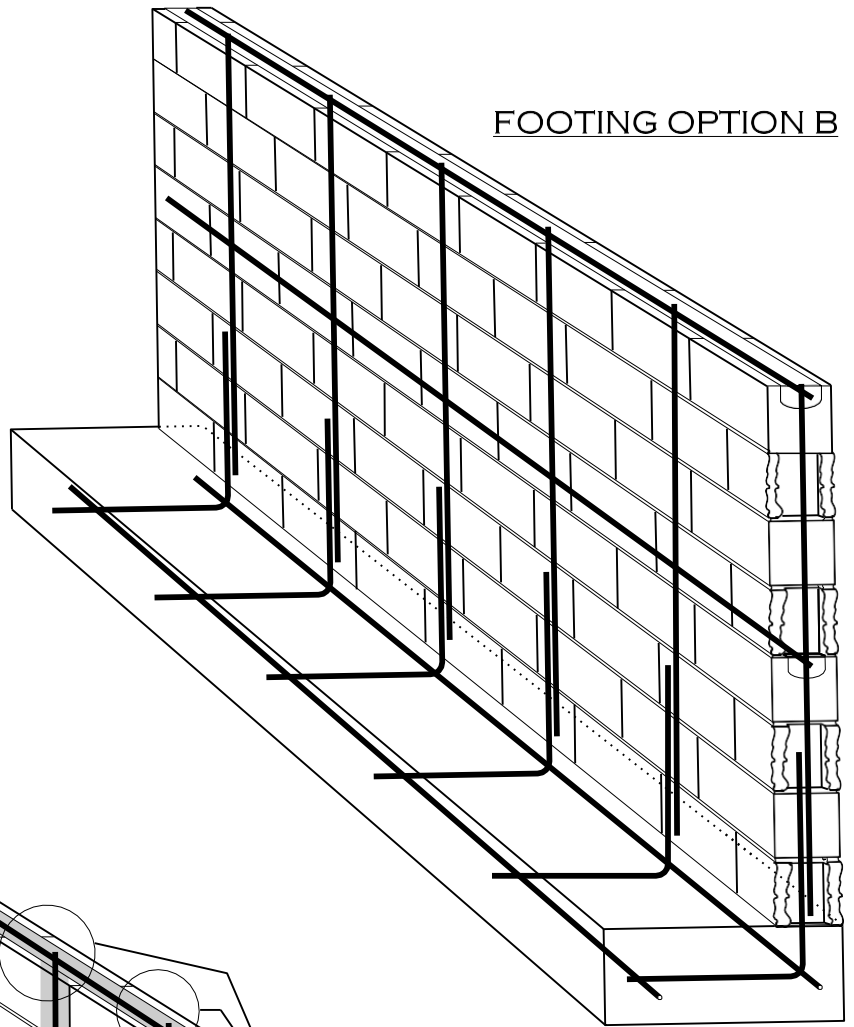

(TYPICAL)  
ONLY CELLS AND BOND BEAM  
COURSES WITH REBAR TO BE  
GROUTED  
(DO NOT SOLID GROUT ENTIRE WALL - USE  
GROUT STOP MESH AS APPROPRIATE)

FOOTING OPTION A

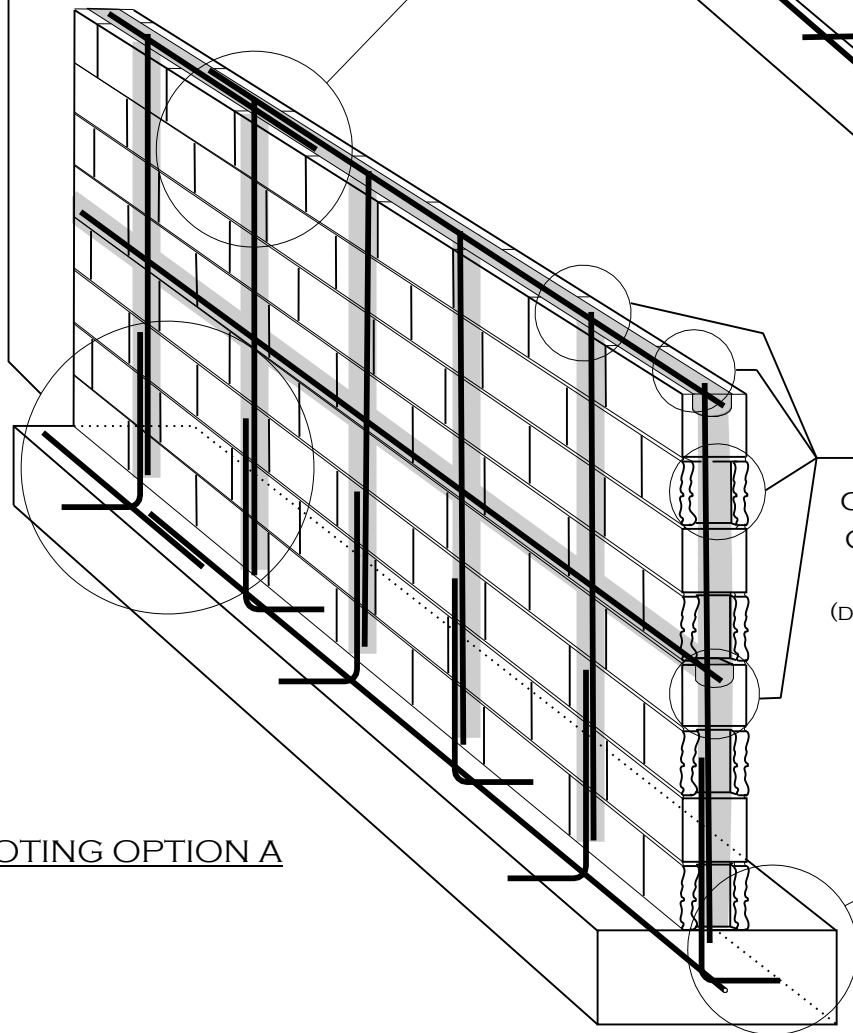

(TYPICAL)  
ALL REBAR SHALL HAVE A  
MINIMUM OF 3" CONCRETE  
COVER AT FOOTINGS

## DESIGN PARAMETERS:

ACTIVE SOIL PRESSURE (PSF) = 30  
 PASSIVE SOIL BEARING (PSF) = 150  
 COEFFICIENT OF FRICTION = 0.25  
 ALLOWABLE SOIL BEARING (PSF) = 1500  
 WIND = 80 MPH, EXPOSURE C  
 SEISMIC:  
 NA=1.3, NV=1.6, Z=0.4, SOIL PROFILE=SD