

# REQUEST FOR PROPOSAL

**Date:** September 14th, 2023

**Type of Work:** Commercial Beautification Program-Construction Repairs

**Project Name:** 2023 Commercial Beautification Program

## **Introduction:**

The City of Desert Hot Springs is seeking qualified contractor to undertake the Commercial Beautification Program, which aims to enhance the aesthetics and overall appeal of commercial properties within the city. This program involves a range of construction and improvement work, including building trash enclosures, painting exteriors, stucco repairs, adobe repairs, installation of new signs, demolition work, masonry, electrical, parking lot asphalt repairs, parking lot striping, landscaping, and other minor commercial construction repairs as needed. The successful contractor will be responsible for completing the scope of work at various locations specified in the exhibit provided. The one contractor will be responsible for the scope of work per location.

## **Point of Contact:**

All communications regarding this RFP should be directed to the following point of contact:

**Name:** Erick Becerril

**Title:** Community Programs Manager

**Email:** Ebecerril@cityofdhs.org

## **Scope of Work:**

The scope of work includes but is not limited to the following:

- Building trash enclosures (per location)
- Painting exterior of buildings (per square foot cost/per project)
- Stucco repairs (per location)
- Adobe repairs (per location)
- Installation of new signs (per location)
- Demolition work (per location)
- Masonry (per location)
- Electrical work (per location)
- Parking lot asphalt repairs (per location)

- Parking lot striping
- Landscaping
- Other minor commercial construction repairs as needed

Please refer to "Exhibit A" for a detailed breakdown of the scope of work at each location.

- 13440 Palm Dr. (Bella Sushi)
- 13180 Palm Dr. (All Star Burger)
- 12525 Palm Dr. (Shopping Center)
- 12235 Palm Dr. (Super Liquor)
- 12347 Palm Dr. (Escapade Tavern)
- 66240 Pierson Blvd. (New Bar)
- 66184 Pierson Blvd. (The Spread)

### **Labor Laws, Prevailing Wages**

- A. All work or services performed within the State of California pursuant to this Agreement by Contractor, Contractor's employees and independent contractors, or Contractor's subcontractors and its subcontractors' employees and independent contractors shall be performed by individuals lawfully permitted to perform such work or services in the State of California and/or the United States of America pursuant to all applicable State and/or Federal labor laws, rules and regulations including, but not limited to, any State or Federal law, rule or regulation prohibiting the employment of undocumented workers or any other person not lawfully permitted to perform said work or services in the State of California or the United States of America.
- B. Contractor represents that it is an equal opportunity employer and shall not discriminate against any subcontractor, employee, or applicant ("person") for employment because of race, denial of family and medical care leave, religious creed (including religious dress and grooming practices), color; national origin (including language use restrictions), ancestry, physical disability or mental disability (including HIV and Aids), medical condition (cancer and genetic characteristics), genetic information, military or veteran status, marital status, gender, gender identity, gender expression, sex (which includes pregnancy, childbirth, breastfeeding and medical conditions related to pregnancy, childbirth or breastfeeding), age or sexual orientation. Unless otherwise permitted under the law, Contractor shall not refuse to hire or employ any such person or refuse to select any such person for a training program leading to employment, or bar or discharge any such person from employment or from a training program leading to employment, or otherwise discriminate against any

such person in compensation or in terms, conditions, or privileges of employment.

- C. Contractor and all of Contractor's subcontractors, if any, shall pay each employee engaged in all applicable trades or occupation not less than the prevailing hourly wage rate for work of a similar character in the locality in which the public work is performed, and not less than the general prevailing rate of per diem wages for holiday and overtime work. In accordance with the provisions of Section 1770 of the California Labor Code ("Labor Code"), the Director of Department of Industrial Relations of the State of California has determined the general prevailing rates of wages and employer payments for health and welfare, pension, vacation, travel time, and subsistence pay as provided for in Labor Code Section 1773.8, apprenticeship or other training programs authorized by Labor Code Section 3093 and similar purposes applicable to the work to be done. Said wages are available through the California Department of Industrial Relations' Internet website at <http://www.dir.ca.gov/dlsr/PWD/index.htm> and are on file at City Hall, as provided in Section 1773.2 of the Labor Code. Said rates shall be posted at the Project site where work is to be performed, in accordance with Labor Code Section 1773.2. Contractor shall access a copy of the wage rate determination and shall make all subcontractors, if any, aware of the determination. As the wage determination for each craft reflects an expiration date, it shall be the Contractor's responsibility to ensure that the prevailing wage rates of concern are current and paid. Subject to the safe harbor provisions of Labor Code Section 1775, Contractor shall forfeit to the City an amount not to exceed two hundred dollars (\$200) for each calendar day or portion thereof, as set by the Labor Commissioner in accordance with the terms of Labor Code section 1775, for each laborer, workmen or mechanics employed that is paid less than the general prevailing rate of wages herein referred to and stipulated for any work done under the proposed contract, by him, or by any subcontractor under him, in violation of the provisions of the Labor Code, and in particular, Sections 1770 to 1781 inclusive. Contractor and any and all or its subcontractors shall forfeit to the City twenty-five dollars (\$25) for each worker employed in the performance of this Agreement for each calendar day during which the worker is required or permitted to work more than eight (8) hours in any one calendar day and forty (40) hours in any one calendar week in violation of the provisions of Section 1813 of the Labor Code. In the event the total cost of the Project is thirty thousand dollars (\$30,000.00) or more, Contractor shall further comply with provisions set forth in Labor Code Section 1777.5 pertaining to employment of properly registered apprentices, including without limitation the obligation to (i) pay employed apprentices the prevailing rate of per diem wages for apprentices in the trade to which he or she is registered and shall be employed only at the work of craft or trade to which he or she is registered; (ii)

- D. employ apprentices in at least the ratio as set forth in said section; (iii) submit contract award information to an applicable apprenticeship program; and (iv) contribute to California Apprenticeship Council.
- E. Contractor and all subcontractors hired to perform any work under the Project shall keep accurate payroll records, including the name, address, social security number, work classification, straight time and overtime hours worked each day and week, and the actual per diem wages paid to each worker, in accordance with Section 1776 of the Labor Code. Payroll records shall be on forms provided by the Division of Labor Standards Enforcement ("DLSE") or in a manner containing the same information as the forms provided by the DLSE. Failure to comply with the above may result in monetary penalties to the Contractor or affected subcontractor. Payroll records shall be verified by written declaration made under penalty of perjury, that the information contained in the records is true and correct. Contractor and any and all subcontractors shall make a certified copy of all payroll records available for inspection by DLSE, the City or any member of the public and otherwise provide certified copies of such records to any of the foregoing within ten (10) days of Contractor's and subcontractor's receipt of written request therefor. Failure to comply with the above may result in monetary penalties, in accordance with Labor Code Section 1776(d) and (h).
- F. Notwithstanding anything else to the contrary, Contractor hereby acknowledges that all contractors and subcontractors must be registered with the Department of Industrial Relations ("Department") pursuant to Labor Code Section 1725.5 in order to be qualified to bid on, be listed in a bid proposal, subject to the requirements of Section 4104 of the Public Contract Code, or engage in the performance of any public work contract, including this Agreement, that is subject to the payment of prevailing wages. The Project is subject to compliance monitoring and enforcement by the Department of Industrial Relations. In accordance with Section 3700 of the Labor Code, Contractor must secure payment of compensation to all Contractor's employees. Contractor represents and warrants that Contractor is registered with the Department in the manner prescribed by the Department and has paid the requisite application fee, as required by Labor Code Section 1725.5. Moreover, prior to Contractor entering into any contracts with any subcontractor, Contractor shall obtain proof that all such subcontractors have also registered with the Department in accordance with Section 1725.5.

**Proposal Submission:**

Interested contractors are requested to submit their proposals no later than two weeks from the date of this RFP. Proposals must be submitted electronically by October 16, 2023 to the point of contact mentioned above. Late submissions will not be accepted. Only submissions with all proposal requirements will be deemed as acceptable bids.

**Proposal Requirements:**

The proposal should include the following information:

- a. Cover Letter: A brief cover letter introducing your company and summarizing your understanding of the project requirements.
- b. Company Profile: A comprehensive overview of your company, including its history, qualifications, experience, and expertise in similar projects. Please provide relevant references.
- c. Cost Estimate: A breakdown of the estimated costs for each component of the scope of work, including materials, labor, equipment, and any additional charges per property.
- d. Insurance and Licensing: Proof of appropriate insurance coverage and valid licenses required to perform the work in the City of Desert Hot Springs.
- e. Project Schedule: A proposed timeline for the completion of the project, including key milestones and deliverables.
- f. References: Contact information for at least three references from previous clients for similar projects.

**Evaluation Criteria:**

Proposals will be evaluated based on the following criteria:

- Experience and qualifications of the contractor and key personnel
- Understanding of the project requirements
- Proposed approach and methodology
- Cost-effectiveness
- Compliance with insurance and licensing requirement
- Ability to meet project timelines
- References from previous client
- Compliance with all of the terms of this proposal

**Important Dates:**

- RFP Issuance Date: September 14, 2023
- Deadline for project questions: September 29, 2023
- Proposal Submission Deadline: October 16, 2023
- Evaluation Period: Following the submission deadline
- Contract Award: Expected within two weeks after the evaluation period

**General Information:**

- a. The City of Desert Hot Springs reserves the right, at any point during this RFP process, to accept or reject any or all proposals received as a result of this RFP.
- b. All costs incurred by contractors in the preparation and submission of their proposals shall be the responsibility of the contractor and will not be reimbursed by the City.
- c. The City of Desert Hot Springs may request additional information or clarifications from any or all proposers during the evaluation period.
- d. The selected contractor will be required to enter into a formal agreement with the City of Desert Hot Springs, outlining the terms and conditions of the project.
- e. The contractor shall be responsible for obtaining any necessary permits, licenses, or approvals required to perform the work in accordance with local regulations.
- f. The City of Desert Hot Springs is committed to promoting diversity, inclusion, and equal opportunity. Minority-owned, women-owned, and disadvantaged business enterprises are encouraged to submit proposals.
- g. The City of Desert Hot Springs reserves the right to visit and inspect any locations specified in the exhibit to verify the accuracy of the proposals.
- h. Any intellectual property developed or created as part of the project shall become the property of the City of Desert Hot Springs.
- i. All information provided by the City of Desert Hot Springs, including the exhibit, is for informational purposes only and may not be used for any other purpose without written permission.
- j. Any changes or amendments to the RFP will be communicated to all interested parties who have obtained the RFP documents from the City of Desert Hot Springs.
- k. The City of Desert Hot Springs shall not be liable for any costs or damages incurred by contractors in connection with the preparation or submission of proposals.

- l. By submitting a proposal, the contractor acknowledges and agrees to the terms and conditions outlined in this RFP.
- m. The City of Desert Hot Springs may, at its discretion, cancel or reissue this RFP at any time without incurring any liability to the proposers.

**Proposals Due Date and Time:** October 16, 2023 at 2:00pm.

**Proposal Submitted to:** Submit proposal via email to [ebecerril@cityofdhs.org](mailto:ebecerril@cityofdhs.org), or drop off in person at:

Attention: Erick Becerril  
11999 Palm Dr.  
Desert Hot Springs CA,

If you have any questions, please feel free to contact me at (760)329-6411 ext. 116, or via email at [ebecerril@cityofdhs.org](mailto:ebecerril@cityofdhs.org).

Sincerely,  
Erick Becerril  
Community Programs Manager

**CONSTRUCTION AGREEMENT  
BY AND BETWEEN  
THE CITY OF DESERT HOT SPRINGS  
AND**

---

THIS PUBLIC WORKS CONSTRUCTION AGREEMENT ("Agreement") is made and entered into this \_\_\_\_ day of \_\_\_\_\_, 20\_\_\_\_, by and between the City of Desert Hot Springs, a municipal corporation located in the County of Riverside, State of California, hereinafter referred to as "City," and \_\_\_\_\_, a \_\_\_\_\_, hereinafter referred to as "Contractor."

**RECITALS**

**WHEREAS**, the City desires to retain Contractor, on an independent contractor basis, to perform [INSERT BRIEF DESCRIPTION OF SERVICES] as more particularly described below; and

**WHEREAS**, Contractor represents that it is fully qualified to perform such services by virtue of its experience and the training, education and expertise of its principals and employees.

**NOW THEREFORE, IN CONSIDERATION OF THE MUTUAL PROMISES AND RELEASES CONTAINED HEREIN, AND FOR OTHER GOOD AND VALUABLE CONSIDERATION, RECEIPT OF WHICH IS HEREBY ACKNOWLEDGED, THE PARTIES AGREE AS FOLLOWS:**

**AGREEMENT**

**1. Incorporation by Reference**

The foregoing recitals are hereby expressly made a part of this Agreement as though fully set forth herein.

**2. Project Information.**

- Location: \_\_\_\_\_ as depicted in Contractor's proposal dated \_\_\_\_\_, 20\_\_\_\_, and attached hereto and incorporated herein as Exhibit "A" ("Scope of Services" or sometimes "Project"). In the event any conflict exists between this Agreement minus the Scope of Services, on the one hand, and the Scope of Services, on the other hand, the former shall supersede.
- Project description, including significant materials to be used and equipment to be installed: \_\_\_\_\_, in the City of Desert Hot Springs, California, as set forth in the Scope of Services.



- License classification applicable to Project: \_\_\_\_\_
- Approximate start date: \_\_\_\_\_
- Approximate completion date: \_\_\_\_\_
- Substantial completion of work evidenced by: Inspection and approval by City Staff.
- It is expressly agreed that except for extensions of time duly granted by the City, in writing, time shall be of the essence.

### 3. **Contractor Information**

- Address: \_\_\_\_\_
- License Number: \_\_\_\_\_

### 4. **Insurance Coverage**

a. Contractor shall procure and maintain at its own expense, until completion of performance and acceptance by the City, commercial general liability insurance of not less than One Million Dollars (\$1,000,000) combined single limit per occurrence, and Two Million Dollars (\$2,000,000) in the aggregate, for bodily injury, personal injury, death, loss or damage resulting from the wrongful or negligent acts by the Contractor or its officers, employees, servants, volunteers and agents and independent contractors. Contractor shall provide insurance on an occurrence, not claims-made basis. Contractor acknowledges and agrees that, for purposes of clarification with the intention of avoiding gaps in coverage with any umbrella or excess insurance, personal and advertising injury coverage shall be triggered by an "offense" while bodily injury and property damage coverage shall be triggered by an "occurrence" during the policy period.

b. Contractor shall further procure and maintain at its own expense, until completion of performance and acceptance by the City, commercial vehicle liability insurance covering personal injury and property damage, of not less than Two Million Dollars (\$2,000,000) combined single limit per occurrence, and Two Million Dollars in the aggregate (\$2,000,000), covering any vehicle utilized by Contractor or its officers, employees, servants, volunteers and agents and independent contractors in performing the services required by this Agreement.

c. Unless Contractor has no employees and is exempt from worker's compensation requirements, Contractor shall further procure and maintain at its expense, until completion of performance and acceptance by the City, workers' compensation insurance providing coverage as required by the California State Workers' Compensation Law. If any class of employees employed by the Contractor pursuant to this Agreement is not protected by the California State Workers' Compensation Law, Contractor shall

provide adequate insurance for the protection of such employees to the satisfaction of the City. Contractor agrees to waive its statutory immunity under any workers' compensation or similar statute, as respecting the City, and to require any and all subcontractors and any other person or entity involved in the Project to do the same.

Worker's Compensation Insurance:

- Contractor has no employees and is exempt from workers' compensation requirements.
- Contractor carries workers' compensation insurance for all employees.

d. All policies required by this section shall be secured from insurers authorized to do business in the State of California with an "A" policyholder's rating or better and a financial rating of at least Class VII, in accordance with the current Best's Ratings.

e. Contractor agrees to require that all parties, including but not limited to subcontractors, architects, engineers or others with whom Contractor enters into contracts or whom Contractor hires or retains pursuant to or in any way related to the performance of this Agreement, provide the insurance coverage required herein, at minimum, and name as additional insureds the parties to this Agreement. Contractor agrees to monitor and review all such coverage and assumes all responsibility for ensuring that such coverage is provided in conformity with the requirements of this Section.

f. In the event this Agreement is terminated for any reason prior to the completion of all obligations and requirements of this Agreement, Contractor agrees to maintain all coverages required herein until the City provides written authorization to terminate the coverages following the City's review and determination that all liability posed under this Agreement as to the party providing insurance has been eliminated.

g. Contractor agrees and acknowledges that if it fails to obtain all of the insurance required in this Agreement in accordance with the requirements herein, or to obtain and ensure that the coverage required herein is maintained by any subcontractors or others involved in any way with the Project, Contractor shall be responsible for any losses, claims, suits, damages, defense obligations, or liability of any kind or nature attributable to the City, and/or their officers, employees, servants, volunteers, agents and independent contractors.

## **5. Insurance Documentation**

a. Contractor shall provide certificates of insurance with original endorsements to the City as evidence of the insurance coverage required herein. Certificates of such insurance shall be filed with the City on or before commencement of performance of this Agreement. Contractor shall ensure that the most current certification of insurance shall be delivered to the City at all times until completion of performance and acceptance by the City.

b. Notwithstanding any inconsistent statement in any required insurance policies or any subsequent endorsements attached thereto, the comprehensive general liability and commercial vehicle liability policies shall bear endorsements whereby it is provided that the City, and its officers, employees, servants, volunteers, agents and independent contractors are named as additional insureds. Additional insureds shall be entitled to the full benefit of all insurance policies in the same manner and to the same extent as any other insureds and there shall be no limitation to the benefits conferred upon them other than policy limits to coverages.

c. Contractor shall require the carriers of all required insurance policies to waive all rights of subrogation against the City, and their officers, employees, servants, volunteers, agents and independent contractors.

d. Each policy required herein must be endorsed to provide that the policy shall not be cancelled or non-renewed by either party, or reduced in coverage or limits (except by paid claims) unless the insurer has provided the City with at least thirty (30) days prior written notice of said cancellation, non-renewal, or reduction, with the exception that only ten (10) days prior written notice shall be required in the event of cancellation for nonpayment of premium.

e. All insurance policies required to be provided by Contractor or any other party must be endorsed to provide that the policies shall apply on a primary and noncontributing basis in relation to any insurance or self-insurance, primary or excess, maintained or available to the City, and their officers, employees, servants, volunteers, agents and independent contractors.

## **6. Security**

a. Contractor shall, concurrently with the execution hereof and to the extent not already completed, furnish a payment bond at no expense to the City, in substantially the same form as that attached hereto and made part hereof as Exhibit "B," in an amount equal to \_\_\_\_\_ Dollars and No Cents (\$ \_\_\_\_\_), as security of the payment of all persons performing labor and furnishing materials in connection with this Agreement. To be acceptable, the surety company must be authorized to do business and have an agent for service of process in California, be on the accredited list of the United States Treasury Department, and have an "A" policyholder's rating and a financial rating of Class V, or better, in accordance with the current Best's Rating.

b. Contractor shall, concurrently with the execution hereof and to the extent not already completed, furnish a performance bond at no expense to the City, in substantially the same form as that attached hereto and made part hereof as Exhibit "C," or deposit an amount with the City equal to \_\_\_\_\_ Dollars and No Cents (\$ \_\_\_\_\_), as security for the faithful performance of this Agreement. To be acceptable, the surety company must be authorized to do business and have an agent for service of process in California, be on the accredited list of the United States Treasury

Department, and have an "A" policyholder's rating and a financial rating of Class V, or better, in accordance with the current Best's Rating.

c. The surety on any and all bonds and the form thereof shall be satisfactory to the City Attorney.

## **7. Compensation; Payments**

a. Contractor shall be paid compensation not to exceed \_\_\_\_\_ Dollars and No Cents (\$\_\_\_\_\_) for the services rendered by Contractor pursuant to this Agreement, including profit, labor and materials.

b. Contractor shall invoice the City for the performance of the services under this Agreement in the amount agreed upon by the parties herein. Subject to the retention provisions below, Contractor shall be paid the amount specified in the invoice within 30 days of receipt by the City, provided that the services reflected in the invoice were performed to the reasonable satisfaction of the City in accordance with the terms of this Agreement.

c. Pursuant to Public Contract Code section 9203, the City shall retain no less than five percent of the compensation to be paid to Contractor which shall be released to the Contractor no later than sixty (60) days from the date of the City's acceptance of the work pursuant to this Agreement.

## **8. Extra Work and Change Orders**

Extra work and change orders shall become a part of this Agreement once the extra work or change order is approved in writing and signed by the City and Contractor, prior to the commencement of any extra work or change in work covered by the change order. The City's form change order shall be used for both extra work and a change in work. The change order must describe the scope of the extra work or change in work, and the cost to be added or subtracted from this Agreement. The City shall not require Contractor to perform any extra work or a change in work without written authorization. A change order shall not be enforceable against the City unless the change order complies with this provision.

## **9. Term**

Contractor will perform the services set forth in the Scope of Services and in any approved change orders pursuant to section 1 of this Agreement, the term of which shall commence as of \_\_\_\_\_, and shall expire one year following the City's acceptance of the work pursuant to this Agreement.

## **10. Independent Contractor**

Contractor shall at all times during the term of this Agreement perform the services described in this Agreement as an independent contractor, and hereby waives any claims for any compensation or benefits afforded to City employees and not to independent contractors.

**11. Civil Code Section 1542 Waiver**

a. Contractor expressly waives any and all rights and benefits conferred upon it by the provisions of section 1542 of the California Civil Code which reads as follows:

“A general release does not extend to claims that the creditor or releasing party does not know or suspect to exist in his or her favor at the time of executing the release and that, if known by him or her, would have materially affected his or her settlement with the debtor or released party.”

b. This waiver shall be effective as a bar to any and all actions, fees, damages, losses, claims, liabilities and demands of whatsoever character, nature and kind that are known or unknown, or suspected or unsuspected, including, without limitation, claims of entitlements under the California Public Employees' Retirement System (CalPERS) that are only afforded to employees and not independent contractors. Contractor further represents and warrants that it understands this waiver and that if it does not understand this waiver, it shall seek the advice of a qualified attorney before executing this Agreement.

\_\_\_\_\_  
Initials

**12. Acceptance of Work**

Acceptance of the work shall be by action of the City Council or its designee. Neither the acceptance nor prior inspections or failure to inspect shall constitute a waiver by the City of any defects in the work. From and after acceptance, the work shall be owned and operated by the City. As a condition to acceptance, Contractor shall certify to the City in writing that all of the work has been performed in strict conformity with this Agreement and that all costs have been paid, satisfactory to the City, guaranteeing such performance.

**13. Warranty**

a. In addition to Contractor's other obligations under this Agreement, Contractor warrants all work and materials to be of good quality and fit for the purpose and intended use. Contractor shall also repair, replace and restore any other work which is displaced in correcting defective work as well as other portions of the work which the City by reason of such defects reasonably suspects may also be defective. In the event of a failure to commence with the compliance of above-mentioned conditions within seven calendar days after being notified in writing or failure to diligently pursue such compliance to completion, the City is hereby authorized to proceed to have the defects repaired and

made good at the expense of Contractor who hereby agrees to pay the cost and charges therefor immediately on demand.

b. If, in the opinion of the City, nonconforming work creates a dangerous condition or requires immediate correction or repair to prevent further loss to the City or to prevent interruption of operations, the City shall attempt to give the Contractor notice. If Contractor cannot be contacted or does not comply with the City's request for correction within a reasonable time as determined by the City, the City may proceed to make such correction or provide such repair. The costs of such correction or repair shall be charged against Contractor, who agrees to make payment for said costs upon demand. Corrective action by the City will not relieve Contractor or Contractor's sureties or insurers of the guarantees and indemnities of this Agreement.

c. This section does not in any way limit the City's remedies available under the law, or the guarantee on any items for which a longer guarantee is specified or on any items for which a manufacturer or supplier gives a longer guarantee period. Contractor agrees to act as a co-guarantor with such manufacturer or supplier and shall furnish the City all appropriate guarantees or warranty certificates upon completion of the project. No manufacturer's guarantee period shall in any way limit the liability of Contractor or Contractor's sureties and insurers under the indemnity or insurance provisions of this Agreement.

#### **14. Indemnification**

a. To the furthest extent allowed by law including California Civil Code section 2782, Contractor shall indemnify, hold harmless and defend the City and each of its officers, officials, employees, agents and volunteers from any and all loss, liability, fines, penalties, forfeitures, costs and damages (whether in contract, tort, or strict liability, including but not limited to personal injury, death at any time and property damage) incurred by City, Contractor, or any other person, and from any and all claims, demands and actions in law or equity (including attorney's fees and litigation expenses), arising or alleged to have arisen directly or indirectly from this Contract. Contractor's obligations under the preceding sentence shall apply regardless of whether City or any of its officers, officials, employees, agents or volunteers are passively negligent, but shall not apply to any loss, liability, fines, penalties, forfeitures, costs or damages caused by the active or sole negligence, or the willful misconduct, of City or any of its officers, officials, employees, agents or volunteers.

If Contractor should subcontract all or any portion of the work to be performed under this Contract, Contractor shall require each subcontractor to indemnify, hold harmless and defend the City and each of its officers, officials, employees, agents and volunteers in accordance with the terms of the preceding paragraph.

This section shall survive termination or expiration of this Contract.

## **15. Default**

a. Failure or delay by any party to this Agreement to perform any material term or provision of this Agreement shall constitute a default under this Agreement; provided however, that if the party who is otherwise claimed to be in default by the other party commences to cure, correct or remedy the alleged default within fifteen days after receipt of written notice specifying such default and shall diligently complete such cure, correction or remedy, such party shall not be deemed to be in default hereunder.

b. The party which may claim that a default has occurred shall give written notice of default to the party in default, specifying the alleged default. Delay in giving such notice shall not constitute a waiver of any default nor shall it change the time of default; provided, however, the injured party shall have no right to exercise any remedy for a default hereunder without delivering the written default notice, as specified herein.

c. Any failure or delay by a party in asserting any of its rights or remedies as to any default shall not operate as a waiver of any default or of any rights or remedies associated with a default.

d. In the event that a default of any party to this Agreement may remain uncured for more than fifteen days following written notice, as provided above, a "breach" shall be deemed to have occurred. In the event of a breach, the injured party shall be entitled to seek any appropriate remedy or damages by initiating legal proceedings.

## **16. Licenses, Certifications and Permits**

Contractor represents that it has obtained and will maintain at all times during the term of this Agreement all professional and/or business licenses, certifications and/or permits necessary for performing the services described in this Agreement.

## **17. Labor Laws, Prevailing Wages**

a. All work or services performed within the State of California pursuant to this Agreement by Contractor, Contractor's employees and independent contractors, or Contractor's subcontractors and its subcontractors' employees and independent contractors shall be performed by individuals lawfully permitted to perform such work or services in the State of California and/or the United States of America pursuant to all applicable State and/or Federal labor laws, rules and regulations including, but not limited to, any State or Federal law, rule or regulation prohibiting the employment of undocumented workers or any other person not lawfully permitted to perform said work or services in the State of California or the United States of America.

b. Contractor represents that it is an equal opportunity employer and shall not discriminate against any subcontractor, employee, or applicant ("person") for employment because of race, religious creed, color, national origin, ancestry, physical disability, mental disability, medical condition, marital status, sex, age or sexual orientation. Unless otherwise permitted under the law, Contractor shall not refuse to hire or employ any such

person or refuse to select any such person for a training program leading to employment, or bar or discharge any such person from employment or from a training program leading to employment, or otherwise discriminate against any such person in compensation or in terms, conditions, or privileges of employment.

c. Contractor and Contractor's subcontractors, if any, are aware of the requirements of California Labor Code Sections 1720 et seq. and 1770 et seq., which require the payment of prevailing wage rates and the performance of other requirements on certain public works and maintenance projects. Contractor and all of Contractor's subcontractors, if any, shall pay each employee engaged in all applicable trades or occupation not less than the prevailing hourly wage rate for work of a similar character in the locality in which the public work is performed, and not less than the general prevailing rate of per diem wages for holiday and overtime work. In accordance with the provisions of Section 1770 of the California Labor Code ("Labor Code"), the Director of Department of Industrial Relations of the State of California has determined the general prevailing rates of wages and employer payments for health and welfare, pension, vacation, travel time, and subsistence pay as provided for in Labor Code Section 1773.8, apprenticeship or other training programs authorized by Labor Code Section 3093 and similar purposes applicable to the work to be done. Said wages are available through the California Department of Industrial Relations' Internet website at <http://www.dir.ca.gov/dlsr/PWD/index.htm> and are on file at City Hall, as provided in Section 1773.2 of the Labor Code. Said rates shall be posted at the Project site where work is to be performed, in accordance with Labor Code Section 1773.2. Contractor shall access a copy of the wage rate determination and shall make all subcontractors, if any, aware of the determination. As the wage determination for each craft reflects an expiration date, it shall be the Contractor's responsibility to ensure that the prevailing wage rates of concern are current and paid. Subject to the safe harbor provisions of Labor Code Section 1775, Contractor shall forfeit to the City an amount not to exceed two hundred dollars (\$200) for each calendar day or portion thereof, as set by the Labor Commissioner in accordance with the terms of Labor Code section 1775, for each laborer, workmen or mechanics employed that is paid less than the general prevailing rate of wages herein referred to and stipulated for any work done under the proposed contract, by him, or by any subcontractor under him, in violation of the provisions of the Labor Code, and in particular, Sections 1770 to 1781 inclusive. Contractor and any and all or its subcontractors shall forfeit to the City twenty-five dollars (\$25) for each worker employed in the performance of this Agreement for each calendar day during which the worker is required or permitted to work more than eight (8) hours in any one calendar day and forty (40) hours in any one calendar week in violation of the provisions of Section 1813 of the Labor Code.

d. Contractor and all subcontractors hired to perform any work under the Project shall keep accurate payroll records, including the name, address, social security number, work classification, straight time and overtime hours worked each day and week, and the actual per diem wages paid to each worker, in accordance with Section 1776 of the Labor Code. Payroll records shall be on forms provided by the Division of Labor Standards Enforcement ("DLSE") or in a manner containing the same information as the



forms provided by the DLSE. Failure to comply with the above may result in monetary penalties to the Contractor or affected subcontractor. Payroll records shall be verified by written declaration made under penalty of perjury, that the information contained in the records is true and correct. Contractor and any and all subcontractors shall make a certified copy of all payroll records available for inspection by DLSE, the City or any member of the public and otherwise provide certified copies of such records to any of the foregoing within ten (10) days of Contractor's and subcontractor's receipt of written request therefor. Failure to comply with the above may result in monetary penalties, in accordance with Labor Code Section 1776(d) and (h).

e. Notwithstanding anything else to the contrary, Contractor hereby acknowledges that all contractors must be registered with the Department of Industrial Relations ("Department") pursuant to Labor Code Section 1725.5 in order to be qualified to bid on, be listed in a bid proposal, subject to the requirements of Section 4104 of the Public Contract Code, or engage in the performance of any public work contract, including this Agreement, that is subject to the payment of prevailing wages. Contractor represents and warrants that Contractor is registered with the Department in the manner prescribed by the Department and has paid the requisite application fee, as required by Labor Code Section 1725.5. Moreover, prior to Contractor entering into any contracts with any subcontractor, Contractor shall obtain proof that all such subcontractors have also registered with the Department in accordance with Section 1725.5.

**18. Notices**

a. Any notice to be provided pursuant to this Agreement shall be in writing, and all such notices shall be delivered by personal service or by deposit in the United States mail, certified or registered, return receipt requested, with postage prepaid, and addressed to the parties as follows:

To the City:                   City Manager  
                                      City of Desert Hot Springs  
                                      11999 Palm Dr.  
                                      Desert Hot Springs, CA 92240  
                                      Telephone: (760) 329-6411  
                                      Facsimile: (760) 288-3129

To Contractor:               \_\_\_\_\_

                                      \_\_\_\_\_

                                      \_\_\_\_\_

                                      \_\_\_\_\_

                                      \_\_\_\_\_

                                      \_\_\_\_\_

b. Notices, payments and other documents shall be deemed delivered upon receipt by personal service or as of the second (2nd) day after deposit in the United States mail.

## 19. General Conditions

a. Severability. If any one or more of the sentences, clauses, paragraphs or sections contained herein is declared invalid, void or unenforceable by a court of competent jurisdiction, the same shall be deemed severable from the remainder of this Agreement and shall not affect, impair or invalidate any of the remaining sentences, clauses, paragraphs or sections contained herein.

b. Governing Law. The validity of this Agreement and any of its terms or provisions, as well as the rights and duties of the parties under this Agreement, shall be construed pursuant to and in accordance with California law.

c. Cumulative Remedies. Except with respect to rights and remedies expressly declared to be exclusive in this Agreement, the rights and remedies of the parties are cumulative and the exercise by either party of one or more of such rights or remedies shall not preclude the exercise by it, at the same or different times, of any other rights or remedies for the same default of any other default by the other party.

d. Venue. All proceedings involving disputes over the terms, provisions, covenants or conditions contained in this Agreement and all proceedings involving any enforcement action related to this Agreement shall be initiated and conducted in the applicable court or forum in Riverside County, California.

e. Litigation Expenses and Attorneys Fees. In the event any action, suit or proceeding is brought for the enforcement of, or the declaration of any right or obligation pursuant to this Agreement or as a result of any alleged breach of any provision of this Agreement, the prevailing party in such suit or proceeding shall be entitled to recover its costs and expenses, including reasonable attorney's fees, from the losing party, and any judgment or decree rendered in such a proceeding shall include an award thereof.

f. Counterparts. This Agreement may be executed in counterparts, each of which shall be deemed to be an original.

g. Entire Agreement. This Agreement contains all of the covenants and agreements between the parties with respect to the subject matter of this Agreement, and supersedes any and all other agreements, either oral or written, between the City and Contractor. Each party to this Agreement acknowledges that no representations, inducements, promises, or agreements have been made by or on behalf of any party except those covenants and agreements embodied in this Agreement. No agreement, statement, or promise not contained in this Agreement shall be valid or binding.

h. Conflicts of Interest. Contractor covenants that it does not have any interest, nor shall it acquire an interest, directly or indirectly, which would conflict in any manner with the performance of Contractor's services under this Agreement. In the event the City officially determines that Contractor must disclose its financial interests by

completing and filing a Fair Political Practices Commission Form 700, Statement of Economic Interests, Contractor shall file the subject Form 700 with City Hall, as specified under the Notice provisions of this Agreement, pursuant to the written instructions provided by the City.

i. Termination. This Agreement may be terminated by the City immediately for cause. The City may terminate this Agreement without cause upon thirty (30) days' written notice of termination. Upon termination, Contractor shall be entitled to compensation for services performed up to the effective date of termination.

**[REMAINDER OF THIS PAGE INTENTIONALLY LEFT BLANK]**

**IN WITNESS WHEREOF**, the parties hereto have caused this Agreement to be executed as of the date first written above.

**CITY OF DESERT HOT SPRINGS**

\_\_\_\_\_

\_\_\_\_\_  
Doria Wilms, Interim City Manager

\_\_\_\_\_  
By Its: \_\_\_\_\_

**ATTEST:**

\_\_\_\_\_  
Jerryl Soriano, CMC, City Clerk

**APPROVED AS TO FORM:**

\_\_\_\_\_  
Jennifer A. Mizrahi, City Attorney

**EXHIBIT "A"**

**SCOPE OF SERVICES**

**SEE ATTACHED PROPOSAL  
DATED SEPTEMBER 14, 2023**

# Exhibit A

## City of Desert Hot Springs Commercial Beautification

### Bid Proposal Form Bella Sushi (13440 Palm Dr.)

Bid Proposal Form for Bella Sushi

- a. Landscaping: \_\_\_\_\_
- b. Trash Enclosure: \_\_\_\_\_

Contractor Name: \_\_\_\_\_

Contractor Title: \_\_\_\_\_

Contractor Signature: \_\_\_\_\_

Date: \_\_\_\_\_

1. Trash Enclosure:

- Per standard city detail.



2. Landscaping:

- Trim or remove overgrown vegetation at the north/east empty lot.



# City of Desert Hot Springs Commercial Beautification

## Bid Proposal Form

### All Star Burger (13180 Palm Dr.)

Bid Proposal Form for All Star Burger

a. Trash Enclosure: \_\_\_\_\_

Contractor Name: \_\_\_\_\_

Contractor Title: \_\_\_\_\_

Contractor Signature: \_\_\_\_\_

Date: \_\_\_\_\_

1. Trash Enclosures:

- Per standard city detail.



# City of Desert Hot Springs Commercial Beautification

## Bid Proposal Form

### Shopping Center (12525 Palm Dr.)

Bid Proposal Form for Shopping Center

- a. Parking lot repairs: \_\_\_\_\_
- b. Monument Sign: \_\_\_\_\_

Contractor Name: \_\_\_\_\_

Contractor Title: \_\_\_\_\_

Contractor Signature: \_\_\_\_\_

Date: \_\_\_\_\_

#### 1. Parking Areas:

- The parking lot requires repairs for potholes, cracks, or other damages. It is recommended to repair and re-stripe the parking lot to clearly mark parking spaces.



#### 2. Signage and Branding:

- It is recommended to repair or replace the existing monument sign.





# City of Desert Hot Springs Commercial Beautification

## Bid Proposal From Super Liquor (12235 Palm Dr.)

Bid Proposal Form for Super Liquor

- a. Exterior Façade: \_\_\_\_\_
- b. Exterior Paint: \_\_\_\_\_
- c. Exterior sign: \_\_\_\_\_
- d. Relocation of exterior window/door grates: \_\_\_\_\_

Contractor Name: \_\_\_\_\_

Contractor Title: \_\_\_\_\_

Contractor Signature: \_\_\_\_\_

Date: \_\_\_\_\_

### 1. Exterior Façade:

- Needs exterior stucco repairs throughout. The temporary chain-link fence with barbwire will need to be removed/replaced with with material approved by planning dept.



### 2. Exterior paint:

- Patch exterior and paint all of exterior.

### 3. Exterior Sign:

- New exterior signage..

### 4. Relocation of exterior window/door grates:

- The relocation of the exterior metal grates on windows is recommend being placed inside of the building in order to reduce blight.



# City of Desert Hot Springs Commercial Beautification

## Bid Proposal Form

### Escapade Tavern (12347 Palm Dr.)

Bid Proposal Form for Escapade Tavern

- a. Exterior Facade: \_\_\_\_\_
- b. Exterior Paint: \_\_\_\_\_
- c. Trash Enclosure: \_\_\_\_\_
- d. Landscaping: \_\_\_\_\_

Contractor Name: \_\_\_\_\_

Contractor Title: \_\_\_\_\_

Contractor Signature: \_\_\_\_\_

Date: \_\_\_\_\_

1. Exterior Facade:

- Repair exterior and prep for paint.



2. Paint:

- The exterior paint is faded, peeling, or significantly damaged.



3. Trash Enclosure:

- Per standard city detail.

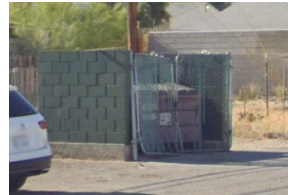

4. Landscaping:

- Trim and clean up exterior landscaping.



5. Exterior Signage:

- Replace exterior signage.

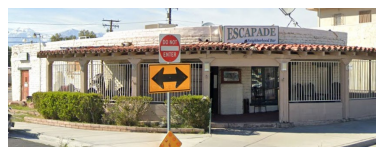

# City of Desert Hot Springs Commercial Beautification

## Bid Proposal Form

### New Bar (66240 Pierson Blvd.)

Bid Proposal Form for New Bar

a. Trash Enclosure: \_\_\_\_\_

b. Exterior Sign: \_\_\_\_\_

Contractor Name: \_\_\_\_\_

Contractor Title: \_\_\_\_\_

Contractor Signature: \_\_\_\_\_

Date: \_\_\_\_\_

1. Trash Enclosures:

- Per standard city detail.

2. Exterior Signage:

- New exterior signage for Bar.



# City of Desert Hot Springs Commercial Beautification

## Bid Proposal Form

### The Spread (66184 Pierson Blvd.)

Bid Proposal Form for New Bar

a. Exterior Sign: \_\_\_\_\_

Contractor Name: \_\_\_\_\_

Contractor Title: \_\_\_\_\_

Contractor Signature: \_\_\_\_\_

Date: \_\_\_\_\_

1. Exterior Signage:

- New exterior signage.





**TRASH ENCLOSURE CONSTRUCTION STANDARDS**

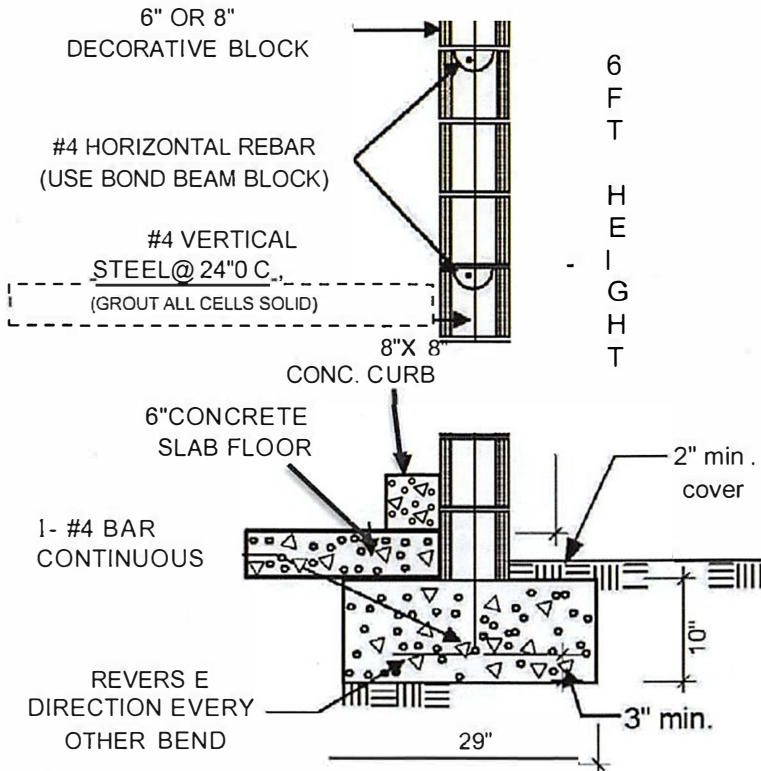

**BLOCK ENCLOSURE DETAIL "A"**

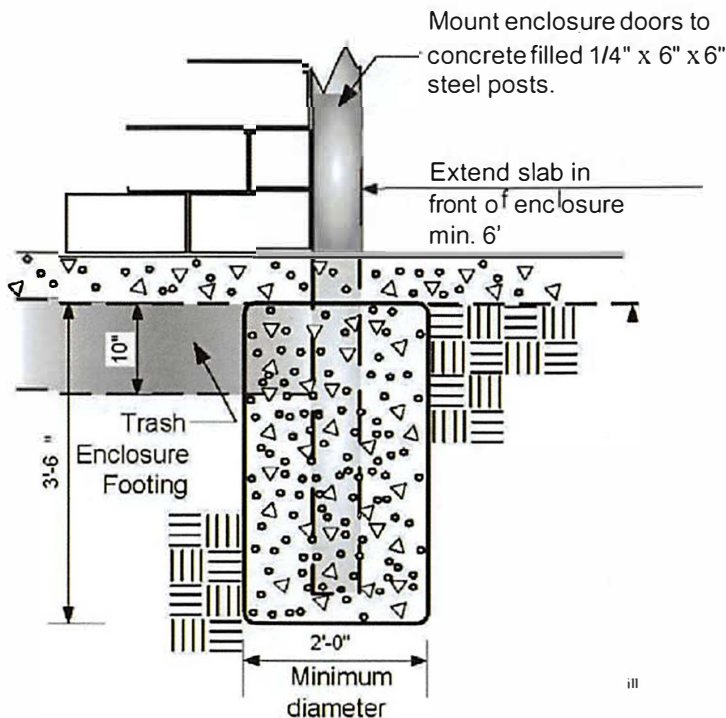

**DOOR FOOTING DETAIL "B"**

- 1.) Walls are to be of decorative block, masonry, or similar materials. (Not precision block)
- 2.) Gates are to be solid and painted to match.
- 3.) Accessible pedestrian access is required if in multi-family areas. See page (4) for these requirements.
- 4.) Double swing gates shall have the swivel spots outside of the opening area of the enclosure. Swivel points shall be attached to concrete filled steel posts/columns at ends of walls.
- 5.) Enclosure shall be on a level pad at ground level. The area between the pad and the pick up area shall be paved area 6" deep for the width of the enclosure and shall not exceed a grade of 2 percent.
- 6.) Enclosures shall be configured, at a minimum of 7'-6" deep with a 6' high decorative wall and a sight obscuring gate. (Specific design criteria refer to Exhibit A or B)
- 7.) 8" x 8" concrete curb around perimeter of enclosure.
- 8.) Maximum wall and gate height to be 6'-0"
- 9.) Trash enclosure shall have a trellis above the gates and enclosure to prevent unauthorized trash dumping into the bins. Said trellis shall be made of steel and painted to match the building trim colors to accentuate the enclosure.
- 10.) TOTAL Enclosure height (including block wall and trellis shall be no more than 8'-0".
- 11.) (3) bays may be required dependent on amount of green waste produced – Per California AB 1826 (See Page 3 for dimensions)

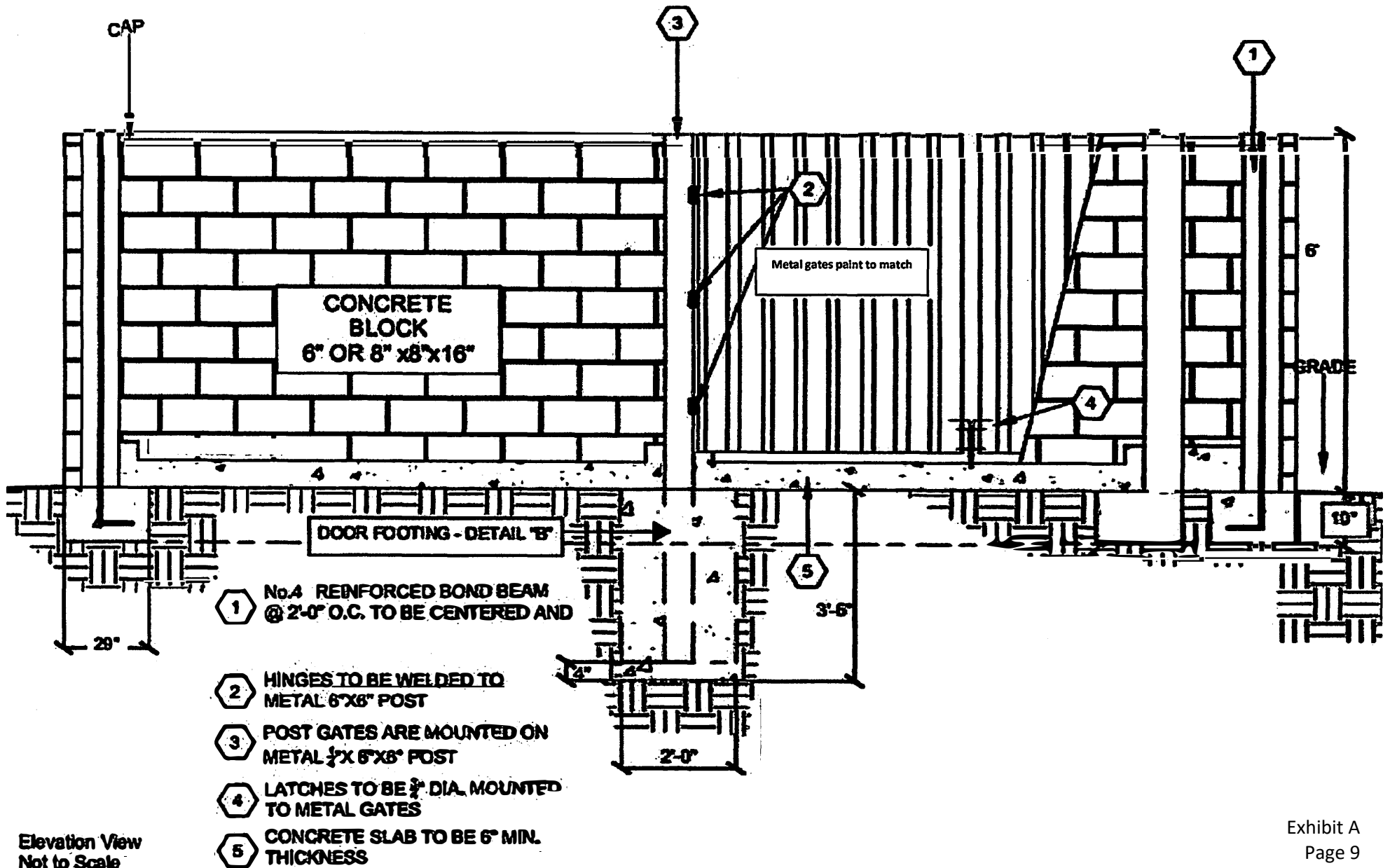

Elevation View  
Not to Scale

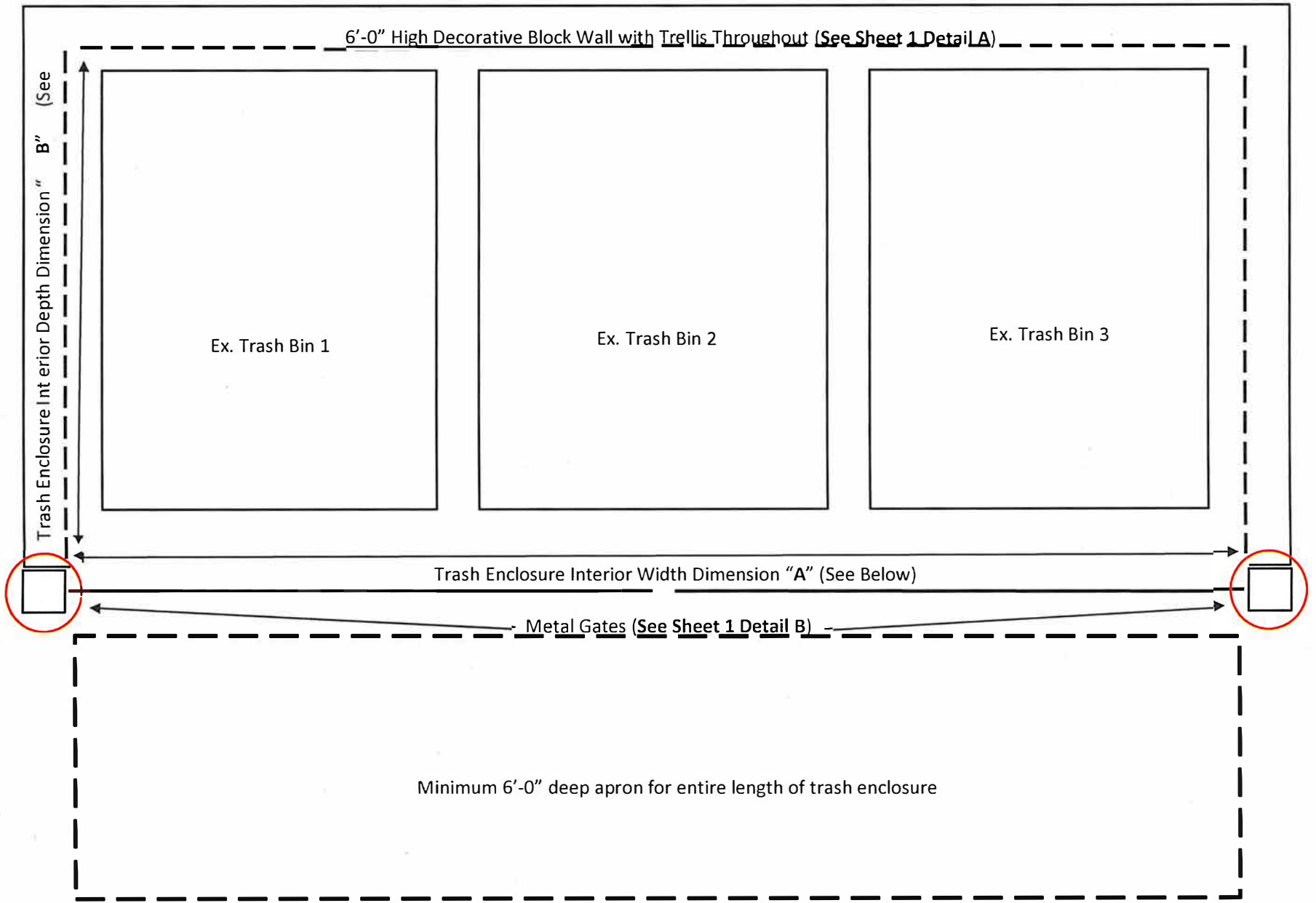

Dimensions for 2 CU. YARD bin:  
 "A" – Width: 11'-0"  
 "B" – Depth: 7'-9"

Dimensions for 3 CU. YARD bin:  
 "A" – Width: 14'-0"  
 "B" – Depth: 7'-9"

Dimensions for 4 CU. YARD bin:  
 "A" – Width: 16'-0"  
 "B" – Depth: 7'-9"

# Accessible Pedestrian Path of Travel Details

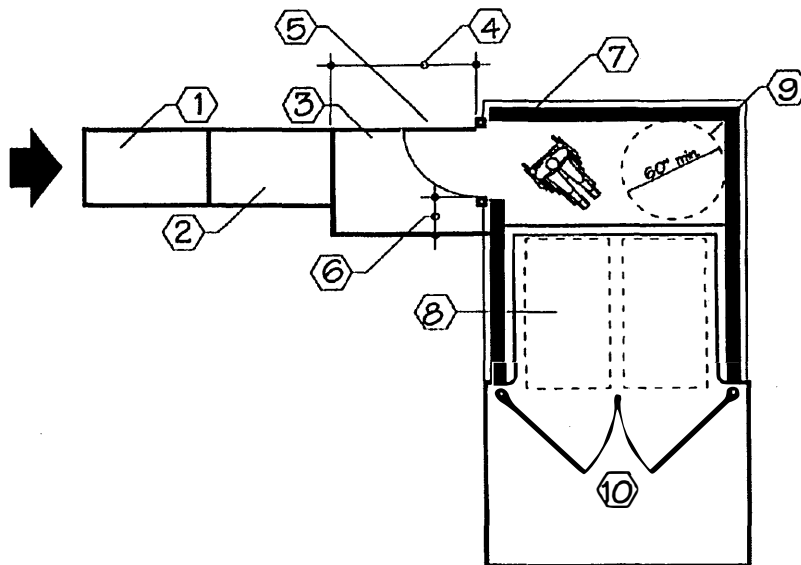
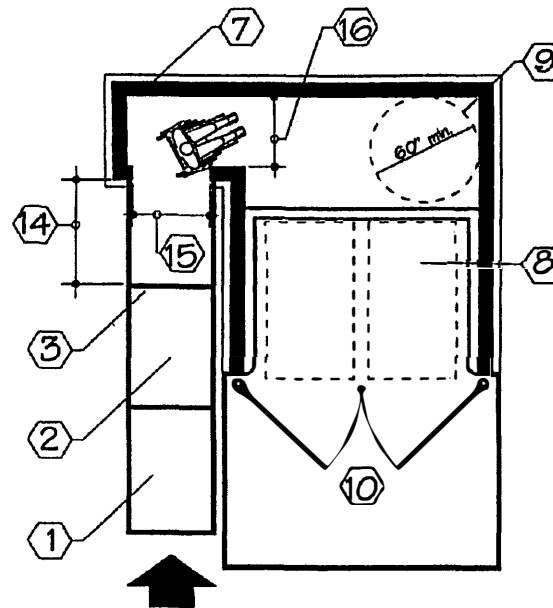
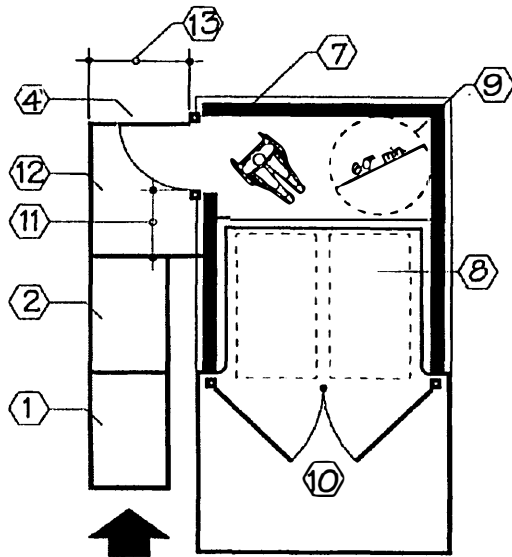

## KEYNOTES

- |  |   |
|--|---|
| 1. Landing @ lower level (min. 6'-0" L.).        | 9. Wheelchair turning circle (min. 60" dia.). |
| 2. Min. 48" wide ramp @ max. 1:12 (8.33%) slope. | 10. Solid sheet metal gates.(Factory Finish)  |
| 3. Landing @ upper level (min. 5'-0" L.) .       | 11. Min. 42" strike-edge clearance.           |
| 4. Solid sheet metal gate width +42" min.        | 12. Level landing.                            |
| 5. Solid sheet metal gate.                       | 13. Min. 5'-0".                               |
| 6. Min. 2'-0" strike-edge clearance.             | 14. Min. 5'-0".                               |
| 7. Decorative block/Tilt Up enclosure walls.     | 15. Min. 42" clear.                           |
| 8. Trash bins.                                   | 16. Min. 48" clear.                           |

## GENERAL NOTES

1. Trash enclosures shall be located in area accessible to trash vehicles. The numbers and locations shall be subject to Community Development Department review and approval.





**EXHIBIT "B"**

**PAYMENT BOND**

We, \_\_\_\_\_, as \_\_\_\_\_ Principal, \_\_\_\_\_ and \_\_\_\_\_, as Surety, jointly and severally, firmly bind ourselves, our heirs, representatives, successors and assigns, as set forth herein, to the City of Desert Hot Springs ("CITY") and those for whose benefit this bond insures in the sum of \_\_\_\_\_ **U.S. Dollars and No Cents (\$\_\_\_\_\_)**. CITY and Principal have entered into an agreement, or are about to enter into the agreement attached hereto and incorporated by reference, for the construction of improvements for the property referenced in said agreement. Surety herein approves of the terms and conditions of said agreement and binds itself to faithfully perform the obligations of Principal therein if Principal fails to so perform. Surety acknowledges that the agreement herein referenced shall be that document as executed by CITY and Principal. If Principal or any of Principal's contractors or subcontractors, fails to pay any of the persons named in Section 9000 *et seq.* of the California Civil Code employed in the performance of the agreement for materials furnished or for labor thereon of any kind, or for amounts due under the Unemployment Insurance Code with respect to such work or labor, then Surety shall pay the same in an amount not exceeding the sum specified above, and also shall pay, in case suit is brought upon this bond, such reasonable attorneys' fees as shall be fixed by the court.

Surety agrees that it shall pay the amounts due the persons above named and diligently perform the agreement upon Principal's default after notice and within the time specified in the agreement. If Surety fails to perform within the times specified in the agreement, Surety shall promptly on demand deposit with CITY such amount as CITY may reasonably estimate as the cost of completing all of Principal's obligations. Surety's obligation for payment herein shall extend, notwithstanding any controversy between Principal and CITY regarding Principal's failure under the agreement. Principal and Surety agree that any payment by Surety pursuant to this paragraph should be conclusively presumed between the parties herein to relieve, as demanded, Surety's obligation herein and shall be deemed proper payment as between Principal and Surety.

This bond shall insure to the benefit of any and all of the persons named in Section 9000 *et seq.* of the California Civil Code so as to give a right of action to them or their assigns in any suit brought upon this bond.

Surety agrees that no change, extension of time, alteration, or addition to the terms of the agreement, or the work to be performed thereunder, or the plans and specifications, or any matters unknown to Surety which might affect Surety's risk, shall in any way affect its obligation on this bond, and it does hereby waive notice thereof.

Principal and Surety agree that should CITY become a party to any action on this bond, that each will also pay CITY'S reasonable attorneys' fees incurred therein in addition to the above sums.

# CITY OF



# DESERT HOT SPRINGS

OFFICE OF THE CITY MANAGER

11-999 Palm Drive • Desert Hot Springs • CA • 92240  
(760) 329-6411 • www.cityofdhs.org

Executed this \_\_\_\_\_ day of \_\_\_\_\_, 20\_\_.

Seal of Corporation

By \_\_\_\_\_  
Authorized Representative of Principal  
Title \_\_\_\_\_

**(ATTACH ACKNOWLEDGEMENT)**

By \_\_\_\_\_  
Authorized Representative of Principal  
Title \_\_\_\_\_

Any claims under this bond may be addressed to: (check one)

Surety's agent for service  
of process in California:

( ) \_\_\_\_\_  
Surety Company

\_\_\_\_\_  
Name

\_\_\_\_\_  
Street Number

\_\_\_\_\_  
Street Number

\_\_\_\_\_  
City and State

\_\_\_\_\_  
City and State

\_\_\_\_\_  
Telephone Number

\_\_\_\_\_  
Telephone Number

By \_\_\_\_\_  
Attorney in Fact or other  
Representative

**(ATTACH ACKNOWLEDGEMENT OF AUTHORIZED REPRESENTATIVE)**

( ) \_\_\_\_\_  
Company Agent

APPROVED AS TO FORM:

\_\_\_\_\_  
Street Number

\_\_\_\_\_  
City and State

\_\_\_\_\_  
City Attorney

Furnish the name, address and phone number of the company agent as well as the surety company.

Sureties must be authorized to do business in and have an agent for service of process in California and be on the accredited list of the United States Treasury Department (their bonds will be limited to such amounts as would be acceptable to the Treasury Department), and otherwise meet the requirements of the agreement.



**EXHIBIT "C"**

**PERFORMANCE BOND**

We, \_\_\_\_\_, as Principal, and \_\_\_\_\_, as Surety, jointly and severally, firmly bind ourselves, our heirs, representatives, successors and assigns, as set forth herein, to the City of Desert Hot Springs ("CITY") for payment of the penal sum of \_\_\_\_\_ **U.S. Dollars and No Cents (\$\_\_\_\_\_)**. CITY and Principal have entered into an agreement, or are about to enter into the agreement attached hereto and incorporated by reference, for the construction of improvements for the property referenced in said agreement. Surety herein approves of the terms and conditions of said agreement and binds itself to faithfully perform the obligations of Principal therein if Principal fails to so perform. Surety acknowledges that the agreement herein referenced shall be that document as executed by CITY and Principal.

THE CONDITION OF THIS OBLIGATION IS SUCH that if the Principal shall in all things stand to and abide by, and well and truly keep and perform all of the covenants, conditions, and provisions in said agreement, and any alteration thereof made as therein provided, on Principal's part to be kept and performed at the time and in the manner therein specified, and shall indemnify and save harmless the CITY, CITY'S engineer, and their consultants, and each of their officials, directors, officers, employees and agents, as therein stipulated, then this obligation shall become null and void; otherwise, it shall be and remain in full force and effect.

Surety agrees that should it fail to take over and diligently perform the agreement upon Principal's default after notice and within the time specified in the agreement, Surety will promptly on demand deposit with CITY such amount as CITY may reasonably estimate as the cost of completing all of Principal's obligations. Surety's obligation for payment herein shall extend, notwithstanding any controversy between Principal and CITY regarding Principal's failure under the agreement should be conclusively presumed between the parties herein to relieve, as demanded, Surety's obligations herein and shall be deemed proper payment as between Principal and Surety.

Surety agrees that no change, extension of time, alteration, or addition to the terms of the agreement, or the work to be performed thereunder or the plans and specifications, or any matters unknown to Surety which may affect Surety's risk shall in any wise affect its obligation on this bond, and it does thereby waive notice thereof.

Principal and Surety agree that if the CITY is required to engage the services of an attorney in connection with the enforcement of this bond, each shall pay CITY'S reasonable attorneys' fees incurred, with or without suit, in addition to the above sum.



Executed this \_\_\_\_\_ day of \_\_\_\_\_, 20\_\_.

Seal of Corporation

By \_\_\_\_\_  
Authorized Representative of Principal  
Title \_\_\_\_\_

By \_\_\_\_\_  
Authorized Representative of Principal  
Title \_\_\_\_\_

**(ATTACH ACKNOWLEDGEMENT OF AUTHORIZED REPRESENTATIVES)**

Any claims under this bond may be addressed to: (check one)

Surety's agent for service  
of process in California:

( ) \_\_\_\_\_  
Surety Company

\_\_\_\_\_  
Name

\_\_\_\_\_  
Street Number

\_\_\_\_\_  
Street Number

\_\_\_\_\_  
City and State

\_\_\_\_\_  
City and State

\_\_\_\_\_  
Telephone Number

\_\_\_\_\_  
Telephone Number

By \_\_\_\_\_  
Attorney in Fact or other  
Representative

**(ATTACH ACKNOWLEDGEMENT OF AUTHORIZED REPRESENTATIVE)**

( ) \_\_\_\_\_  
Company Agent

\_\_\_\_\_  
Street Number

APPROVED AS TO FORM:

\_\_\_\_\_  
City and State

\_\_\_\_\_  
City Attorney

\_\_\_\_\_  
Telephone

Furnish the name, address and phone number of the company agent as well as the surety company.

Sureties must be authorized to do business in and have an agent for service of process in California and be on the accredited list of the United States Treasury Department (their bonds will be limited to such amounts as would be acceptable to the Treasury Department), and otherwise meet the requirements of the agreement.

**CITY OF**



**DESERT HOT SPRINGS**

---

OFFICE OF THE CITY MANAGER

11-999 Palm Drive • Desert Hot Springs • CA • 92240  
(760) 329-6411 • [www.cityofdhs.org](http://www.cityofdhs.org)

**[REMAINDER OF THIS PAGE INTENTIONALLY LEFT BLANK]**