



**REGULAR MEETING OF THE CITY COUNCIL
CITY OF JACKSON, MISSISSIPPI**

June 27, 2017

AGENDA

6:00 PM

CALL TO ORDER BY THE PRESIDENT

INVOCATION

1. **REVEREND BETTY HAMPTON OF SANDERS CHAPEL CME CHURCH**

PUBLIC HEARING

INTRODUCTIONS

PUBLIC COMMENTS

CONSENT AGENDA

2. **NOTE: "ALL MATTERS LISTED UNDER THE CONSENT AGENDA ARE CONSIDERED TO BE ROUTINE BY THE CITY COUNCIL AND WILL BE ENACTED BY ONE MOTION IN THE FORM LISTED BELOW. THERE WILL BE NO SEPARATE DISCUSSION OF THESE ITEMS. IF DISCUSSION IS DESIRED, THAT ITEM WILL BE REMOVED FROM THE CONSENT AGENDA AND CONSIDERED SEPARATELY."**
3. **ORDER ACCEPTING PAYMENT OF \$11,408.00 FROM LIBERTY MUTUAL INSURANCE COMPANY ON BEHALF OF ITS INSURED (UPS-BRIAN GATES) AS A PROPERTY DAMAGE SETTLEMENT. (JOINER, YARBER)**

INTRODUCTION OF ORDINANCES

ADOPTION OF ORDINANCE

4. **ORDINANCE OF THE CITY OF JACKSON, MISSISSIPPI ADOPTING THE 2015 EDITION OF THE INTERNATIONAL PROPERTY MAINTENANCE CODE, REGULATING AND GOVERNING THE CONDITIONS AND MAINTENANCE OF ALL PROPERTY, BUILDINGS AND STRUCTURES; BY PROVIDING THE STANDARDS FOR SUPPLIED UTILITIES AND FACILITIES AND OTHER PHYSICAL THINGS AND CONDITIONS ESSENTIAL TO ENSURE THAT STRUCTURES ARE SAFE, SANITARY AND FIT FOR OCCUPATION AND USE; AND THE CONDEMNATION OF BUILDINGS AND STRUCTURES UNFIT FOR HUMAN OCCUPANCY AND FEES THEREOF, AMENDING 26-511 ET SEQ., OF THE JACKSON, MISSISSIPPI CODE OF ORDINANCES AND REPEALING 2003-47(2) OF**

THE CITY OF JACKSON, MISSISSIPPI AND ALL OTHER ORDINANCES OR PARTS OF LAWS IN CONFLICT THEREWITH. (HENDRIX, BARRETT-SIMON)

5. **ORDINANCE OF THE CITY COUNCIL OF JACKSON, MISSISSIPPI AMENDING SECTION 66-44 OF THE CODE OF ORDINANCES OF JACKSON, MISSISSIPPI TO REVISE PROCEDURES FOR PROVIDING NOTICE, HEARING, ASSESSING COSTS AND PENALTIES AND TO ENACT CRIMINAL PENALTIES FOR REPEATED VIOLATIONS RESULTING IN THE CLEANING OF PROPERTY CONSIDERED TO CONSTITUTE A MENACE TO PUBLIC HEALTH, SAFETY, AND WELFARE. (HENDRIX, BARRETT-SIMON, STAMPS)**

REGULAR AGENDA

6. **CLAIMS (DAY, YARBER)**
7. **PAYROLL (DAY, YARBER)**
8. **ORDER AUTHORIZING THE SELL OF A 1992 E-ONE LADDER FIRE TRUCK TO THE HINDS COUNTY BOARD OF SUPERVISORS FOR THE RAYMOND VOLUNTEER FIRE DEPARTMENT. (ALL WARDS) (SIMPSON, YARBER)**
9. **ORDER AUTHORIZING THE MAYOR'S SUBMISSION AND ACCEPTANCE OF THE FUNDING OPPORTUNITY ANNOUNCEMENT AND STAKEHOLDER INPUT GRANT PROGRAM ADMINSTRATED BY MISSISSIPPI OFFICE OF HOMELAND SECURITY. (VANCE, YARBER)**
10. **ORDER AUTHORIZING THE MAYOR TO ENTER INTO A TWELVE MONTH AGREEMENT WITH SCHINDLER ELEVATOR CORPORATION FOR ELEVATOR MAINTENANCE TO BE USED BY JATRAN AT THE JATRAN ADMINISTRATIVE/MAINTENANCE FACILITY COMMENCING MAY 1, 2017. (ALL WARDS) (JEFFERSON, YARBER)**
11. **ORDER AUTHORIZING THE MAYOR TO EXECUTE A MEMORANDUM OF UNDERSTANDING BETWEEN THE CITY OF JACKSON, MISSISSIPPI, AND MISSISSIPPI ROAD MAP TO HEALTH EQUITY AND URBAN LEAGUE, INCORPORATED, FOR THE LEASE AND MANAGEMENT OF THE CITY'S GROVE PARK MUNICIPAL GOLF COURSE. (JONES, YARBER)**
12. **ORDER RATIFYING A CONTRACT WITH HEMPHILL CONSTRUCTION COMPANY FOR THE LONGWOOD DRIVE EMERGENCY WATER & SEWER REPAIR, CITY PROJECT NO. 17B0501.601. (WARD 6) (SMASH, YARBER)**
13. **ORDER AUTHORIZING THE MAYOR TO EXECUTE A PRELIMINARY ENGINEERING SERVICES CONTRACT WITH WAGGONER ENGINEERING, INC., FOR THE STATE STREET RESURFACING PROJECT (FORTIFICATION STREET TO WOODROW WILSON AVENUE), FEDERAL AID PROJECT NO. STP-6928-00(013) LPA/107548, CITY PROJECT NO. 17B4001. (WARD 7) (SMASH, YARBER)**
14. **ORDER AUTHORIZING ACCEPTANCE AND DONATION OF PERMANENT EASEMENTS BETWEEN THE CITY OF JACKSON AND THE STATE OF MISSISSIPPI FOR THE LEFLEUR EAST TRAIL. (SMASH, YARBER)**

15. **ORDER AUTHORIZING THE MAYOR TO EXECUTE SUPPLEMENTAL AGREEMENT #1 TO THE CONTRACT OF HEMPHILL CONSTRUCTION COMPANY, INC. FOR THE TRAFFIC CALMING PROJECT, FEDERAL AID PROJECT NUMBER TCSP-0250-00(046)/103924, CITY PROJECT 31500. (ALL WARDS) (SMASH, YARBER)**
16. **ORDER ACCEPTING THE BID OF W. E. BLAIN & SONS, INC. FOR CONSTRUCTION OF TERRY ROAD RESURFACING PROJECT, FEDERAL AID PROJECT NUMBER STP-7286-00(003)/106995, CITY PROJECT NUMBER 14B4002, AND AUTHORIZING THE MAYOR TO EXECUTE A CONTRACT WITH SAID COMPANY SUBJECT TO THE CONCURRENCE OF THE MISSISSIPPI TRANSPORTATION COMMISSION. (WARDS 6&7) (SMASH, YARBER)**
17. **ORDER RATIFYING A CONTRACT WITH UTILITY CONSTRUCTORS, INC., FOR THE WEST STREET EMERGENCY SEWER REPAIR, CITY PROJECT NO. 17B0502.701. (WARD 7) (SMASH, YARBER)**
18. **ORDER AUTHORIZING THE MAYOR TO EXECUTE A PRELIMINARY ENGINEERING SERVICES CONTRACT WITH MICHAEL BAKER INTERNATIONAL, FOR THE WOODROW WILSON AVENUE RESURFACING FROM MILL STREET TO I-55, FEDERAL AID PROJECT NO. STP-7281-00(004) LPA/107549-701000, CITY PROJECT NO. 17B4003.701. (WARD 7) (SMASH, YARBER)**
19. **ORDER AUTHORIZING THE MAYOR TO EXECUTE A PRELIMINARY ENGINEERING SERVICES CONTRACT WITH STANTEC CONSULTING SERVICES, INC., FOR THE MCDOWELL ROAD OVER CANEY CREEK BRIDGE REPLACEMENT, FEDERAL AID PROJECT NO. STP-8280-00(003) LPA/107540-701000, CITY PROJECT NO. 17B4502.901. (WARDS 5 & 6) (SMASH, YARBER)**
20. **ORDER AUTHORIZING THE PAYMENT TO EMPIRE TRUCK SALES LLC, FOR THE REPAIR OF VACTOR COMBINATION SEWER CLEANER TRUCK. (SMASH, YARBER)**
21. **ORDER AUTHORIZING THE MAYOR TO EXECUTE ANY AND ALL DOCUMENTS FOR THE CORPS OF ENGINEERS SECTION 592 PROGRAM AGREEMENT. (SMASH, YARBER)**
22. **ORDER ACCEPTING AN ENGINEERING SERVICES AGREEMENT WITH CORNERSTONE ENGINEERING, LLC, FOR THE CABANISS CIRCLE STREET AND DRAINAGE IMPROVEMENT PROJECT, CITY PROJECT NUMBER 17B5003.401. (WARD 4) (SMASH, YARBER)**
23. **ORDER REVISING THE FISCAL YEAR 2016-2017 BUDGET OF THE DEPARTMENT OF PUBLIC WORKS. (ALL WARDS) (SMASH, YARBER)**
24. **ORDER REVISING THE FISCAL YEAR 2016-2017 BUDGET OF THE DEPARTMENT OF PUBLIC WORKS. (ALL WARDS) (SMASH, YARBER)**
25. **ORDER AUTHORIZING THE MAYOR TO EXECUTE A MEMORANDUM OF UNDERSTANDING WITH THE GREATER EASTOVER FOUNDATION. (WARD 1) (SMASH, YARBER)**
26. **ORDER AUTHORIZING THE DONATION OF A MATCHING CONTRIBUTION OF \$6,000 TO GENERAL MISSIONARY BAPTIST STATE**

CONVENTION YOUNG PEOPLES DEPARTMENT IN SUPPORT OF THE DEVELOPMENT, PROMOTION AND COORDINATION OF THE ARTS WITHIN THE CITY AND AUTHORIZING THE MAYOR TO EXECUTE A CONTRACT WITH THE ORGANIZATION. (STOKES)

27. **RESOLUTION OF THE CITY COUNCIL OF JACKSON, MISSISSIPPI IN SUPPORT OF RECOGNIZING COUNCILWOMAN MARGARET BARRETT SIMON FOR UNSELFISH DEDICATION AND DILIGENCE IN SERVICE TO OUR CITY, STATE AND NATION. (STOKES)**
28. **RESOLUTION OF THE CITY COUNCIL OF JACKSON, MISSISSIPPI IN SUPPORT OF RECOGNIZING COUNCIL PRESIDENT TYRONE HENDRIX FOR VIBRANT LEADERSHIP AND SERVICE. (STOKES)**
29. **RESOLUTION OF THE CITY COUNCIL OF JACKSON, MISSISSIPPI ENCOURAGING THE CORPORATE OFFICES OF SAVE-A-LOT GROCERY STORE TO RECONSIDER PERMANENTLY CLOSING ITS NAKOMA DRIVE LOCATION. (PRIESTER)**
30. **ORDER OF THE CITY COUNCIL OF JACKSON, MISSISSIPPI REVISING FISCAL YEAR 2016-2017 BUDGET TO FUND A PART-TIME POSITION IN THE OFFICE OF THE CITY CLERK. (STAMPS)**
31. **ORDER REVISING THE FISCAL YEAR 2016-2017 BUDGET OF THE DEPARTMENT OF PARKS AND RECREATION. (WARDS 3, 4) (JONES, YARBER)**

DISCUSSION

32. **DISCUSSION: 2017 MUNICIPAL ELECTION CONTRACT WITH HINDS COUNTY (HENDRIX)**
33. **DISCUSSION: WATER/SEWER REVENUE UPDATE (HENDRIX)**
34. **DISCUSSION: JACKSON ZOO (STOKES)**
35. **DISCUSSION: WATER BILLS (STOKES)**
36. **DISCUSSION: MUNICIPAL TAX COLLECTIONS (STAMPS)**
37. **DISCUSSION: CODE ENFORCEMENT (STAMPS)**

PRESENTATION

38. **PRESENTATION: PRESENTATION TO MAYOR AND COUNCIL RECOGNIZING THE CITY'S HELP AND SUPPORT IN MAKING AN AWARD WINNING DEVELOPMENT POSSIBLE. (YARBER)**
39. **PRESENTATION: WARD 4 PRESENTATION (STAMPS)**
40. **PRESENTATION: WARD SIX PRESENTATION (HENDRIX)**

PROCLAMATION

41. **PROCLAMATION PROCLAIMING JUNE 2017 BE DECLARED NATIONAL SAFETY MONTH IN THE CITY OF JACKSON, MS (YARBER)**
42. **PROCLAMATION RECOGNIZING COMEDIAN RITA B. OF JACKSON, MS FOR HER ACCOMPLISHMENTS, SHARING HER GIFT OF LAUGHTER AS WELL AS POSITIVE REPRESENTATION OF OUR GREAT CITY. (YARBER)**

RESOLUTIONS

43. RESOLUTION OF THE CITY COUNCIL OF JACKSON, MISSISSIPPI HONORING AND COMMENIDNG MR. ALLEN ANTHONY JONES AS AN INCOMPARABLE DIRECTOR OF PARKS AND RECREATION UPON HIS RETIREMENT. (STOKES)
44. RESOLUTION OF THE CITY COUNCIL OF JACKSON, MISSISSIPPI HONORING AND COMMENDING MR. LOUIS ARMSTRONG, A DEDICATED AND INNOVATIVE SERVANT, UPON HIS RETIREMENT. (STOKES)

REPORT FROM MEMBERS, MAYOR, DEPARTMENT DIRECTORS

ANNOUNCEMENTS

ADJOURNMENT

AGENDA ITEMS IN COMMITTEE

ALL ITEMS IN COMMITTEE

FINANCE

1. Order of the City Council of Jackson, Mississippi authorizing an across the board pay raises for City employees for FY 2014-2015. (Cooper-Stokes) (07/01/14)
2. Ordinance establishing responsible banking and community reinvestment practices within the City of Jackson. (Stamps) (08/12/14)
3. Order of the City Council of Jackson, Mississippi authorizing the retention of professional services to assist with the budget preparation for FY2016. (Stokes) (08/25/15)
4. Order revising unrestricted general fund reserve policy. (Stokes) (06/14/16)
5. Order of the City Council of Jackson, Mississippi authorizing the placement of two million dollars from the fund balance of the City budget to be transferred to the City of Jackson Police Department's budget. (Stokes) (11/1/16)

ECONOMIC/DEVELOPMENT

1. Discussion: Joint Economic strategies for the Metrocenter by the City of Jackson and Hinds County (Tillman) (11/10/14)
2. Discussion: Costco (Yarber) (06/02/15)
3. Discussion: The Landmark Building (Yarber) (06/02/15)
4. Discussion: Farish Street (Yarber) (06/02/15)
5. Ordinance of the City Council of Jackson, Mississippi establishing the Business Development Fund within the city of Jackson. (Hendrix) (10/08/15)
6. Discussion: Black on Black Crime (Stamps) (04/04/17)

EDUCATION

1. Resolution of the City Council of Jackson, Mississippi in opposition to locating charter schools in public schools that are currently in operation. (Cooper-Stokes) (04/08/14)

LEGISLATIVE

1. Agenda Item #31 on 03/25/14 Regular Council Agenda regarding 2% sales tax applying to Jackson Convention center debt. (03/24/14) Work Session discussion
2. Discussion: Motorcycle safety and awareness (Cooper-Stokes) 09/09/14

ALL ITEMS IN COMMITTEE

PLANNING

1. Ordinance amending and re-enacting a City of Jackson Curfew Ordinance, Chapter 86, Article II, of the Code of Ordinances City of Jackson, Mississippi to establish a curfew applicable to juveniles to within the City of Jackson. (Stokes) (7/26/11)
2. Ordinance of the City Council of Jackson, Mississippi renaming Amite Street (from Gallatin Street to Robinson Street) to Dr. John M. Perkins Drive. (Stokes) (8/24/10)
3. Ordinance of the City Council of Jackson, Mississippi renaming of Cleary Street (from Dalton Street to the Dead End) to Rev. Dr. Emmett C. Burns, Jr. Drive. (Stokes) (9/6/11)
4. Ordinance of the City Council of Jackson, Mississippi establishing the honorary renaming of Medgar Evers Blvd. (from Ridgeway Street to Martin Luther King, Jr. Drive) to Reverend Curtis W. Houston Drive. (Cooper-Stokes) (7/10/12)
5. Ordinance of the City Council of Jackson, Mississippi requiring sprinkler systems in buildings housing flammable materials. (Cooper-Stokes) (9/4/12)
6. Ordinance of the City Council of Jackson, Mississippi establishing the renaming of Flag Chapel Rd. (from Northside Drive to Cynthia Road) to Nathaniel Booker Road. (Bluntson) (05/28/13)
7. Resolution of the City Council of Jackson, Mississippi encouraging the enhanced use of cell phone towers in the City. (Cooper-Stokes) (01/14/14)
8. Ordinance amending the 2008 amendment to the Capital City Smoke-Free Air Ordinance of 2003, codified as Chapter 86, Article VI, of the Code of Ordinances, City of Jackson, Mississippi. (Whitwell) (01/14/14)
9. A Resolution authorizing the Mayor or his designee to enter into a marketing agreement with Utility Service Partners Private Label, Inc. DBA Service Line Warranties of America, to license the use of the City of Jackson trademark in conjunction with marketing communications to the City of Jackson residents about warranty plans for the repair of water and sewer lines on residential property, to receive trademark licensing fees, and for other purposes. (Stamps) (02/27/14)
10. Ordinance of the City Council of Jackson, Mississippi to rename two streets: Gun Street for Albert Barber, Jr. and Hume Street for Jason Murphy, two teenage African American males who were double homicide victims in the City of Jackson in July 2013. (Cooper-Stokes) (3/11/14)
11. Discussion Item: City Land Bank Operations (Stamps) (3/25/14)
12. Ordinance of the City Council of Jackson, Mississippi renaming Battlefield Park in honor of the late Jackson Mayor Chokwe Lumumba. (Cooper-Stokes) (08/14/14) & (11/18/14)
13. Ordinance of the City Council of Jackson, Mississippi regulating the operation of drones in the city limits and requiring the registration of drones. (Cooper-Stokes) (09/09/14)
14. Ordinance of the City Council of Jackson, Mississippi requiring no-touch temperature checks of passengers arriving at City-owned airports. (Cooper-Stokes) (10/30/14)

ALL ITEMS IN COMMITTEE

15. Ordinance of the City Council of Jackson, Mississippi requiring the closure of nuisance nightclubs. (Cooper-Stokes) (11/4/14)
16. Ordinance of the City Council of Jackson, Mississippi requiring security personnel at convenience stores during hours of operation. (Cooper-Stokes) (11/4/14)
17. Discussion: Parking meters and parking in downtown Jackson (Priester) (02/24/15)
18. Ordinance of the City Council of Jackson, Mississippi renaming Gymnasium Drive (from Bullard Street to Dead end) to James Rice, Jr. Drive. (Stokes) (10/06/15)
19. Ordinance of the City Council of Jackson, Mississippi regulating public accommodations for restroom facilities. (Stokes) (11/03/15)
20. Ordinance of the City Council of Jackson, Mississippi renaming Flag Chapel Road (from Clinton Boulevard to Northside Drive) to President Barack Obama Drive. (Stamps) (01/12/16)
21. Ordinance of the City Council Of Jackson, Mississippi establishing the renaming of Valley Street from Highway 80 to Raymond to Rev. Dr. R. L. T. Smith Drive. (Stokes) (02/09/16)
22. Ordinance of the City Council of Jackson Mississippi regulating the annual water sampling of Municipal water for the detection of contaminants of lead or copper. (Hendrix, Stamps) (02/09/16)
23. Ordinance of the City of Jackson, Mississippi amending Chapter 126 of the Jackson Municipal Code of Ordinances to modernize the regulation of vehicles for hire of the City of Jackson, Mississippi. (Priester) (03/10/16)
24. Ordinance of the City Council of Jackson, Mississippi naming the downtown Jatran Bus Transfer Station in honor of Mrs. Rosa Parks. (Stokes) (04/19/16)
25. Ordinance of the City Council of Jackson, Mississippi renaming Morris Street (from Jefferson Street to Commerce Street to Corrice Collins Drive). (Stokes) (04/19/16)
26. Order authorizing a one year moratorium on certain new business licenses in the City of Jackson. (Stamps) (05/03/16)
27. Ordinance of the City Council of Jackson, Mississippi renaming Tombigbee Street (from Congress Street to West Street) to Travis E. Knight Drive. (Stokes) (07/12/16)
28. Ordinance of the City Council of Jackson, Mississippi renaming a portion of Ridgeway Street (from Bailey Avenue to the Dead End) to Doug L. Anderson Street. (Stokes) (08/23/16)
29. Order requesting the City Council review and vote to approve the sign variance request for Jackson Public Schools to erect a 726 sq. ft. Led Billboard within a SUD zone which does not allow billboards. (Jefferson, Yarber) (09/06/16)
30. Order requesting the City Council review and vote to deny the sign variance request for Jackson Public Schools to erect a 726 sq. ft. Led Billboard within a SUD zone which does not allow billboards. (Jefferson, Yarber) (09/06/16)

ALL ITEMS IN COMMITTEE

31. Order requesting the City Council review and vote to approve the sign variance request for Jackson Public Schools to erect a three sided/faced LED Billboard within a SUD zone which does not allow three sided/faced billboards. (Jefferson, Yarber) (09/06/16)
32. Order requesting the City Council review and vote to deny the sign variance request for Jackson Public Schools to erect a three sided/faced LED Billboard within a SUD zone which does not allow three sided/faced billboards. (Jefferson, Yarber) (09/06/16)
33. Order of the City Council of Jackson, Mississippi authorizing payment to Lori Swanier for claim number 9555 in an amount not to exceed four hundred sixty-one dollars. (Stokes) (10/04/16)
34. Order authorizing the Mayor to retain Attorney Terris C. Harris for legal services for the City of Jackson, Mississippi against Siemens Industry, Inc. and possibly others. (Stokes) (10/04/16)
35. Ordinance of the City Council of Jackson, Mississippi requiring security personnel at convenience stores during hours of operations from 12:00 a.m. to 6:00 a.m. (Stokes) (10/18/16)
36. Ordinance of the City Council of Jackson, Mississippi establishing the renaming of Vardaman Street (from Bailey Avenue to Bailey Avenue Extension) to Al Joyner Way. (Stokes) (11/1/16)
37. Order rescinding the ordinance of the City Council of Jackson, Mississippi renaming Langley Avenue (from Silas Brown Street to Winter Street) to Dr. Raymond O. Biard Drive. (Stamps) (11/1/16)
38. Ordinance of the City Council of Jackson, Mississippi establishing a five dollar per room rental fee for hourly motel rentals. (Stokes) (11/15/16)
39. Ordinance of the City Council of Jackson, Mississippi establishing the renaming of Pearl Street (from Dalton Street to Prentiss Street) to Coach Paul Covington Drive. (Stokes) (11/29/16)
40. Ordinance of the City Council of Jackson, Mississippi renaming Bailey Avenue (from Bailey Avenue Extension to Woodrow Wilson) to Tommie Hathorn Way. (Stokes) (12/27/16)
41. Order requesting the City Council review and vote to approve the sign variance request for Circle K to erect a 224 sq. ft. ground sign at 35 feet in height in the high street overlay district which allows monument signs to only be 25 sq. ft. in size with a maximum height of 6 feet. (Jefferson, Yarber) (01/10/17)
42. Order requesting the City Council review and vote to deny the sign variance request for Circle K to erect a 224 sq. ft. ground sign at 35 feet in height in the high street overlay district which allows monument signs to only be 25 sq. ft. in size with a maximum height of 6 feet. (Jefferson, Yarber) (01/10/17)
43. Ordinance of the City Council of Jackson, Mississippi to regulate security at apartments with 25 or more rental units. (Stokes) (02/21/17)
44. Ordinance of the City Council of Jackson, Mississippi naming Road of Remembrance Park as Alfredteen Brown Harrison Park. (Stokes) (03/07/17)
45. Ordinance amending Chapter 102 – Signs, Article II. Sign regulations, Section 102-32, Prohibited signs, of the Code of Ordinances of the City of Jackson, Mississippi to prohibit any outdoor sign that contains any message or depiction of a sexually explicit nature. (Stamps) (03/07/17)

ALL ITEMS IN COMMITTEE

46. Ordinance amending sections of Chapter 62 of the Code of Ordinances City of Jackson, Mississippi, governing Flood Damage Prevention and for related purposes. (Smash, Yarber) (03/21/17)
47. Ordinance of the City Council of Jackson, Mississippi renaming Pear Street to Reverend Jesse Sutton, Jr. Street. (Stamps) (04/04/17)
48. Ordinance of the City Council of Jackson, Mississippi renaming Carnes Street (from Palmyra Street to Martin Luther King, Jr., Dr.) to Reverend Alvin Burton, Sr. Street. (Stokes) (04/18/17)
49. Ordinance of the City Council of Jackson, Mississippi renaming Cohea Street (from Palmyra Street to Lamar Street) to Corporal Allen Harper, Jr. Street. (Stokes) (04/18/17)
50. Ordinance of the City Council of Jackson, Mississippi renaming Todd Street (from Palmyra Street to Martin Luther King, Jr. Dr.) to Andre Lamont Jones Street. (Stokes) (04/18/17)
51. Order declaring parcel 73-26 surplus property and authorizing disposal of same to River Place, LLC for development of housing. (Jefferson, Yarber) (06/13/17)
52. Order declaring parcel 72-56 surplus property and authorizing disposal of same to River Place, LLC for development of housing. (Jefferson, Yarber) (06/13/17)
53. Order declaring parcel 72-37 surplus property and authorizing disposal of same to River Place, LLC for development of housing. (Jefferson, Yarber) (06/13/17)
54. Order declaring parcel 73-29-1 surplus property and authorizing disposal of same to River Place, LLC for development of housing. (Jefferson, Yarber) (06/13/17)
55. Order declaring parcel 72-58 surplus property and authorizing disposal of same to River Place, LLC for development of housing. (Jefferson, Yarber) (06/13/17)
56. Order declaring parcel 72-52 surplus property and authorizing disposal of same to River Place, LLC for development of housing. (Jefferson, Yarber) (06/13/17)
57. Order declaring parcel 72-55 surplus property and authorizing disposal of same to River Place, LLC for development of housing. (Jefferson, Yarber) (06/13/17)
58. Order declaring parcel 73-22 surplus property and authorizing disposal of same to River Place, LLC for development of housing. (Jefferson, Yarber) (06/13/17)

RULES

1. Ordinance of the City Council of Jackson, Mississippi prohibiting high speed chases from outside jurisdictions into the city limits of Jackson, Mississippi. (Stokes) (04/21/15)
2. Ordinance of the City Council of Jackson, Mississippi prohibiting the sale/purchase of synthetic marijuana, aka... kush, spice, k2, etc. (Stokes) (04/21/15)

ALL ITEMS IN COMMITTEE

3. Ordinance of the City of Jackson, Mississippi on the procedures for erection of public access gates for neighborhoods. (Jefferson, Yarber) (10/18/16)
4. Order repealing the ordinance of the City of Jackson, Mississippi amending procedures for the erection of public access gates to neighborhoods, codified as chapter 110-28, Article I of the Code of Ordinances, City of Jackson, Mississippi in its entirety. (Jefferson, Yarber) (10/18/16)
5. Ordinance of the City of Jackson, Mississippi amending section 110-28 of the City of Jackson, Mississippi Code of Ordinances procedures for the erection of public access gates to neighborhoods. (Foote) (02/21/17)

GOVERNMENT OPERATIONS

1. Discussion: Minority participation (Stokes) (06/02/15)
2. Discussion: 21st Century policing (Stamps) (06/02/15)
3. Discussion: EBO (Yarber) (06/02/15)
4. Ordinance of the City Council of Jackson, Mississippi amending Chapter 2 Administration, Article Iv, Departments, Section 2-336, of the Code Of Ordinances of the City of Jackson, Mississippi to delete Constituent Services and Information as a department and to remove Youth Court as a principal function of police. (Stamps) (09/06/16)
5. Ordinance amending Section 2-325 of the Jackson Code of Ordinances to include qualifications for the position of Chief Administrative Officer. (Stamps) (11/1/16)

Updated: 08/25/2015; 08/26/2015; 09/09/15; 09/23/15; 10/08/15; 10/27/15; 11/04/15; 11/17/15; 12/01/15; 12/16/15; 01/13/16; 02/02/2016; 02/17/16; 03/11/16; 04/11/16; 04/19/16; 05/04/16; 05/10/16;05/18/16; 05/31/16; 06/06/16; 06/14/16; 07/13/16; 08/11/16; 08/24/16; 09/08/16; 09/28/16; 10/07/16; 11/1/16; 11/2/16; 11/9/16; 11/15/16; 11/21/16; 12/22/16; 12/28/16; 01/11/17; 02/07/17; 03/13/17; 03/20/17; 04/05/17; 06/09/17; 06/13/17



CITY OF JACKSON, MISSISSIPPI
AGENDA ITEM DETAIL

REVEREND BETTY HAMPTON OF SANDERS CHAPEL CME CHURCH

- 1. **Brief Description/Purpose:** REVEREND BETTY HAMPTON OF SANDERS CHAPEL CME CHURCH
- 2. **Public Policy Initiative:**
- 3. **Who will be affected?**
- 4. **Benefits:**
- 5. **Schedule:**
- 6. **Location:**
- 7. **Action implementd by:**
- 8. **COST:**
- 9. **Source of Funding:**
- 10. **EBO Participation:**

Contract Information- if applicabile

Vendor Name:

Department Contact:

Contract Value:

Contract Start Date:

Contract End Date:

ATTACHMENTS:

Description	Upload Date	Type
No Attachments Available		



CITY OF JACKSON, MISSISSIPPI
AGENDA ITEM DETAIL

NOTE: "ALL MATTERS LISTED UNDER THE CONSENT AGENDA ARE CONSIDERED TO BE ROUTINE BY THE CITY COUNCIL AND WILL BE ENACTED BY ONE MOTION IN THE FORM LISTED BELOW. THERE WILL BE NO SEPARATE DISCUSSION OF THESE ITEMS. IF DISCUSSION IS DESIRED, THAT ITEM WILL BE REMOVED FROM THE CONSENT AGENDA AND CONSIDERED SEPARATELY."

NOTE: "ALL MATTERS LISTED UNDER THE CONSENT AGENDA ARE CONSIDERED TO BE ROUTINE BY THE CITY COUNCIL AND WILL BE ENACTED BY ONE MOTION IN THE FORM LISTED BELOW. THERE WILL BE NO SEPARATE DISCUSSION OF THESE ITEMS. IF DISCUSSION IS DESIRED, THAT ITEM WILL BE REMOVED FROM THE CONSENT AGENDA AND CONSIDERED SEPARATELY."

- 1. **Brief Description/Purpose:**
- 2. **Public Policy Initiative:**
- 3. **Who will be affected?**
- 4. **Benefits:**
- 5. **Schedule:**
- 6. **Location:**
- 7. **Action implementd by:**
- 8. **COST:**
- 9. **Source of Funding:**
- 10. **EBO Participation:**

Contract Information- if applicable

Vendor Name:

Department Contact:

Contract Value:

Contract Start Date:



CITY OF JACKSON, MISSISSIPPI
AGENDA ITEM DETAIL

ORDER ACCEPTING PAYMENT OF \$11,408.00 FROM LIBERTY MUTUAL INSURANCE COMPANY ON BEHALF OF ITS INSURED (UPS-BRIAN GATES) AS A PROPERTY DAMAGE SETTLEMENT. (JOINER, YARBER)

- 1. **Brief Description/Purpose:** IT IS HEREBY ORDERED by the City Council for the City of Jackson, Mississippi, that the City Attorney or designee, be authorized to execute all necessary documents and accept payment in the amount of \$11,408.00 as a property damage settlement for damage sustained to the City of Jackson property on March 23, 2017.
- 2. **Public Policy Initiative:** Not Applicable
- 3. **Who will be affected?** CITY OF JACKSON
- 4. **Benefits:** N/A
- 5. **Schedule:** N/A
- 6. **Location:** N/A
- 7. **Action implementd by:** OFFICE OF THE CITY ATTORNEY
- 8. **COST:** N/A
- 9. **Source of Funding:** GENERAL FUND
- 10. **EBO Participation:**

Contract Information- if applicable

Vendor Name:

Department Contact:

Contract Value:

Contract Start Date:

Contract End Date:

Office of the City Attorney

455 East Capitol Street
Post Office Box 2779
Jackson, Mississippi 39207-2779
Telephone: (601) 960-1799
Facsimile: (601) 960-1756

OFFICE OF THE CITY ATTORNEY

This **ORDER ACCEPTING PAYMENT OF \$11,408.00 FROM LIBERTY MUTUAL INSURANCE COMPANY ON BEHALF OF ITS INSURED (UPS-BRIAN GATES) AS A PROPERTY DAMAGE SETTLEMENT** is legally sufficient for placement in NOVUS Agenda.



Monica D. Joiner, City Attorney

DATE

OFFICE OF THE CITY ATTORNEY
6/12/17

OFFICE OF THE CITY ATTORNEY
6/12/17 BB

ORDER ACCEPTING PAYMENT OF \$11,408.00 FROM LIBERTY MUTUAL INSURANCE COMPANY ON BEHALF OF ITS INSURED (UPS-BRIAN GATES) AS A PROPERTY DAMAGE SETTLEMENT.

IT IS HEREBY ORDERED by the City Council for the City of Jackson, Mississippi, that the City Attorney or designee, be authorized to execute all necessary documents and accept payment in the amount of \$11,408.00 as a property damage settlement for damage sustained to the City of Jackson property on March 23, 2017.

APPROVED FOR AGENDA:

City Attorney
Risk Manager
CAO
Mayor's Office

Initials	Date
<u> 20 /</u>	<u> 6-8-17 </u>
_____	_____
_____	_____

Item # _____
Agenda Date: 27 JUNE 2017
By: Yarber, Joiner, Poullard

06/08/2017
(tbp)

CITY COUNCIL AGENDA ITEM 10 POINT DATA SHEET

06/08/2017
DATE

POINTS		COMMENTS								
1.	1. Brief Description/Purpose	ORDER ACCEPTING PAYMENT OF \$11,408.00 FROM LIBERTY MUTUAL INSURANCE COMPANY ON BEHALF OF ITS INSURED (UPS-BRIAN GATES) AS A PROPERTY DAMAGE SETTLEMENT								
2.	Public Policy Initiative 2. Crime Prevention 3. Changes in City Government 4. Neighborhood Enhancement 5. Economic Development 6. Infrastructure and Transportation 7. Quality of Life	N/A								
3.	Who will be affected	City of Jackson								
4.	Benefits	N/A								
5.	Schedule (beginning date)	N/A								
6.	Location: ▪ WARD ▪ CITYWIDE (yes or no) (area) ▪ Project limits if applicable	N/A								
7.	Action implemented by: ▪ City Department <input checked="" type="checkbox"/> ▪ Consultant <input type="checkbox"/>	Office of the City Attorney								
8.	COST	N/A								
9.	Source of Funding ▪ General Fund <input type="checkbox"/> ▪ Grant <input type="checkbox"/> ▪ Bond <input type="checkbox"/> ▪ Other <input type="checkbox"/>	GENERAL FUND								
10.	EBO participation	ABE	_____ %	WAIVER	yes	___	no	___	N/A	<u> X </u>
		AABE	_____ %	WAIVER	yes	___	no	___	N/A	<u> X </u>
		WBE	_____ %	WAIVER	yes	___	no	___	N/A	<u> X </u>
		HBE	_____ %	WAIVER	yes	___	no	___	N/A	<u> X </u>
		NABE	_____ %	WAIVER	yes	___	no	___	N/A	<u> X </u>

COPY



RECEIVED

PER-500

APR 12 2017

THE CITY OF JACKSON, MISSISSIPPI
GENERAL PURPOSE ACCIDENT / LOSS REPORT RISK MANAGEMENT

SECTION I. TO BE COMPLETED BY SUPERVISORY PERSONNEL

For City vehicle accident/loss use Per-26 (Accident/loss Report involving City vehicle.)
For injuries to City employees use Per-24 (Report of personal injury.)

POLICE / CITY CASE NO.

2017-04536D

Rev'd Copy
4/15/17

CITY INFORMATION	1. CITY DEPARTMENT AND DIVISION <i>Public Works / Traffic</i>		2. TELEPHONE <i>601-960-1757</i>	3. DATE OF ACCIDENT/LOSS <i>3/23/17</i>	4. TIME OF ACCIDENT/LOSS <i>5:16 pm</i>
	5. NAME OF PERSON PREPARING REPORT <i>Nathan Lighter</i>		6. JOB TITLE <i>Traffic Superintendent</i>		7. TELEPHONE <i>601-960-1761</i>
PARTY RESPONSIBLE FOR DAMAGE	8. DESCRIBE ANY DAMAGE TO CITY PROPERTY INVOLVED <i>Master arm upright structure hit, and pedestrian signal broken.</i>				
	9. DESCRIBE ANY DAMAGE TO CITY PROPERTY (ALSO, NOTE WHETHER DAMAGE WAS HEAVY/MODERATE/LIGHT) <i>Heavy</i>				
INJURIES OTHER THAN EMPLOYEE	10. NAME OF PERSON WHO DAMAGED CITY PROPERTY <i>Brian Gates</i>		11. ADDRESS <i>136 Mockingbird Ln Ripley, MS</i>		12. TELEPHONE <i>662-587-0324</i>
	13. PLACE OF EMPLOYMENT <i>United Parcel Service</i>		14. ADDRESS		15. TELEPHONE
	16. NAME AND ADDRESS OF INSURANCE COMPANY <i>Mississippi Auto Liability Ins / AS2-C21-004175-336</i>				
WITNESSES	18. NAME	19. AGE	20. ADDRESS	21. TELEPHONE	22. DESCRIPTION OF INJURY
	23. NAME	24. ADDRESS	25. TELEPHONE	26. LOCATION AT TIME OF ACCIDENT/LOSS	
ACCIDENT/LOSS DESCRIPTION	27. LOCATION OF ACCIDENT/LOSS'S NAME OF NEAREST INTERSECTION <i>State St. @ Pascagoula St / Jackson MS</i>			28. WEATHER CONDITIONS <i>Good</i>	
	29. DESCRIBE HOW ACCIDENT/LOSS OCCURRED. USE ADDITIONAL PAPER IF NEEDED. <i>Driver struck mast arm structure with traffic signal, ped signal and street light attached.</i>				

(CONTINUE ON BACK)

Rec'd
Miss

PER-500

#313 Already in system 4/4/17
Top

The City of Jackson, Mississippi General Purpose Accident Report

DO NOT WRITE IN THE
SPACE FOR PERSONNEL
USE ONLY

POLICE / CITY CASE NO.

COPY (4/12/17)

For City vehicle accidents use Per-26 (Accident Report involving City vehicle)
For injuries to City Employees use Per-24 (Report of personal injury)

2017-045360

CITY INFORMATION	1. CITY DEPARTMENT AND DIVISION Department of Public Works / Infrastructure Management		2. TELEPHONE 960-1168	3. DATE OF ACCIDENT 3/23/2017	4. TIME OF ACCIDENT 5:16PM
	5. NAME OF PERSON PREPARING REPORT Leroy Lee		6. JOB CLASSIFICATION Infrastructure Manager		7. TELEPHONE 960-1168
	8. DESCRIBE CITY PROPERTY INVOLVED pedestrian signal (electric box), cross-walk sign post, and the street light				
	9. DESCRIBE ANY DAMAGE TO CITY PROPERTY (ALSO, NOTE WHETHER DAMAGE WAS HEAVY/MODERATE/LIGHT) Damage to pedestrian signal (electric box), cross-walk sign post, and the street light (damage was light)				
PARTY RESPONSIBLE	10. NAME OF PERSON WHO DAMAGED CITY PROPERTY Brian Gates		11. ADDRESS 136 Mockingbird Ln/Ripley, MS		12. TELEPHONE 662-587-0324
	13. PLACE OF EMPLOYMENT UPS Truck (US DOT 021800)		14. ADDRESS Jackson, MS		15. TELEPHONE 601-968-3636
	16. NAME OF INSURANCE COMPANY Liberty Mutual Insurance	17. TELEPHONE	18. NAME OF INSURANCE AGENT		19. TELEPHONE
OTHER THAN EMPLOYEE	20. NAME N/A		21. AGE	22. ADDRESS	23. TELEPHONE
	24. INJURY				
WITNESSES	25. NAME Leroy Lee		26. ADDRESS 200 S. President Jackson, MS		27. TELEPHONE 601-960-1168
	28. LOCATION AT TIME OF ACCIDENT at the intersection of State Street and Pascagoula Street				
	29. LOCATION OF ACCIDENT/NAME OF NEAREST INTERSECTING STREET State Street and Pascagoula Street				
ACCIDENT DESCRIPTION	30. WEATHER CONDITIONS dry streets				
	31. DESCRIBE HOW ACCIDENT OCCURRED USE ADDITIONAL PAPER IF NEEDED UPS 18-wheeler truck, traveling southbound on State Street and, upon turning left onto Pascagoula Street, caused damage to the pedestrian signal (electric box), cross-walk sign post, and the street light. The Jackson Police Department was contacted and an officer arrived on the scene and generated a police report.				
	See attached pictures and Vehicle Crash Report Form (2017-045360)				
32. PREPARER'S SIGNATURE <i>Georgia Swins</i>		33. DATE 3.27.17	34. DIVISION OR DEPARTMENT HEAD'S SIGNATURE <i>[Signature]</i>		35. DATE 27.MAR.17

NOTE: DEPARTMENT HEAD IS RESPONSIBLE FOR FORWARDING ORIGINAL AND TWO DUPLICATE COPIES OF COMPLETED REPORT TO PERSONNEL DEPARTMENT WITHIN 24 HOURS AFTER RECEIVING NOTIFICATION OF DAMAGE TO CITY PROPERTY.

NO 4/13/17

LEWIS ELECTRIC, INC.

QUOTE

P.O. BOX 320337
FLOWOOD, MS 39232-0337
601-932-0101 / 601-709-0866 (FAX)
FED ID #64-0823637

DATE	QUOTE #
3/31/2017	17033101

PROJECT NAME/LOCATION
STATE STREET @ PASCAGOULA
JACKSON MS

QTY	DESCRIPTION	UNIT	PRICE	TOTAL
10.00	Replace Traffic Signal Shaft on Existing Foundation; Reuse Signal Heads, Arm, and Wire	LS	\$ 11,408.00	\$ 11,408.00
TOTAL ITEMS:				\$ 11,408.00

NOTES:

1.00 Lewis Electric is a certified WBE Contractor

Daniel Steadham

Daniel Steadham / Estimator
601-580-2391 / 601-932-0101



CITY OF JACKSON
CLAIMS/RISK MANAGEMENT DIVISION
REVENUE TRANSMITTAL FORM

DATE: 5/31/17

RECEIVED FROM: Liberty Mutual Insurance (UPS)
Insurance Company 9 Claimant 9 Bank 9 Overpayment 9 Other 9

Comments: CLAIM # 11380 D/L: 3/23/17 Vehicle # N/A
Division#: 001 451 10 6316

- 9 COUNCIL ORDER
- 9 REIMBURSEMENT/REFUND
- 9 LIABILITY

Financial Data:

Check# 50-937/213 \$ 11,408.00
Check# _____ \$ _____
Check# _____ \$ _____

TOTAL DEPOSIT\$ 11,408.00

<u>Account Number (s)</u>	<u>Description of Payment</u>	<u>Amount Paid</u>
<u>001 5795</u>	<u>DAMAGES TO STREET LIGHT</u>	<u>\$11,408.00</u>
_____	_____	_____
_____	_____	_____

Prepared by: *MacDarrell Poullard*

VERIFY THE AUTHENTICITY OF THIS MULTI-TONE SECURITY DOCUMENT. CHECK BACKGROUND AREA CHANGES COLOR GRADUALLY FROM TOP TO BOTTOM.

AHE * 000072
2000 WESTWOOD DRIVE
WAUSAU, WI 54401



B. CODE
002

50-937/213
CHECK NUMBER
40321989

PAY ► **\$11408.00****

<u>DATE OF CHECK</u>	<u>PAYMENT IDENTIFICATION</u>
05/25/17	AB949-318589-01

VOID IF NOT PRESENTED WITHIN 6 MONTHS OF DATE OF CHECK

JPMORGAN CHASE BANK, N.A./SYRACUSE, NEW YORK

PAY TO THE ORDER OF

CITY OF JACKSON
218 S. PRESIDENT ST, PO BOX 17
JACKSON, MS 39205-0017

OFFICE NO.
949

NOT VALID IN EXCESS OF \$11,408*

CLAIM OFFICE ADDRESS
 2000 WESTWOOD DRIVE
 WAUSAU, WI 54401
 CONTACT: TANAEL, K
 PHONE: 1-847-645-9233



ECK NUMBER	CHECK DATE
40321989	05/25/17
CHECK AMOUNT	BLOCK NUMBER
\$11408.00	000072

ACCIDENT DATE: 03/23/17
 INSURED: UNITED PARCEL SERVICE INC.

CLAIM NO. AB949-318589-01
 POLICY NO. AS2C210041755337044

CLAIMANT:
 CITY OF JACKSON

INSURED OPERATOR:

COV TYPE	PROVIDER	SERVICE FROM - THRU	CHARGE CODE	ADJUST CODE	PAID AMOUNT
LIPD		03/23/17 - 03/23/17			11408.00

PAYMENT SENT TO:
 CITY OF JACKSON

COPY OF PAYMENT EXPLANATION TO:

SUB TOTAL 1 11408.00
 DEDUCTIBLE 0.00
 SUB TOTAL 2 11408.00
 WITHHOLDING TAX 0.00
 CHECK AMOUNT 11408.00

LIAB: LIABILITY - PROP DAMAGE

COVERAGE TYPES

ADJUSTMENT CODE NOTES

RECEIVED

MAY 30 2017

RISK MANAGEMENT DIVISION

EOB NOTES
 FULL/FINAL SETTLEMENT OF DAMAGES TO TRAFFIC SIGNAL SHAFT
 STATE STREET @ PASCAGOULA STREET

CAREFULLY DETACH CHECK BEFORE DEPOSITING - RETAIN STATEMENT FOR YOUR RECORDS



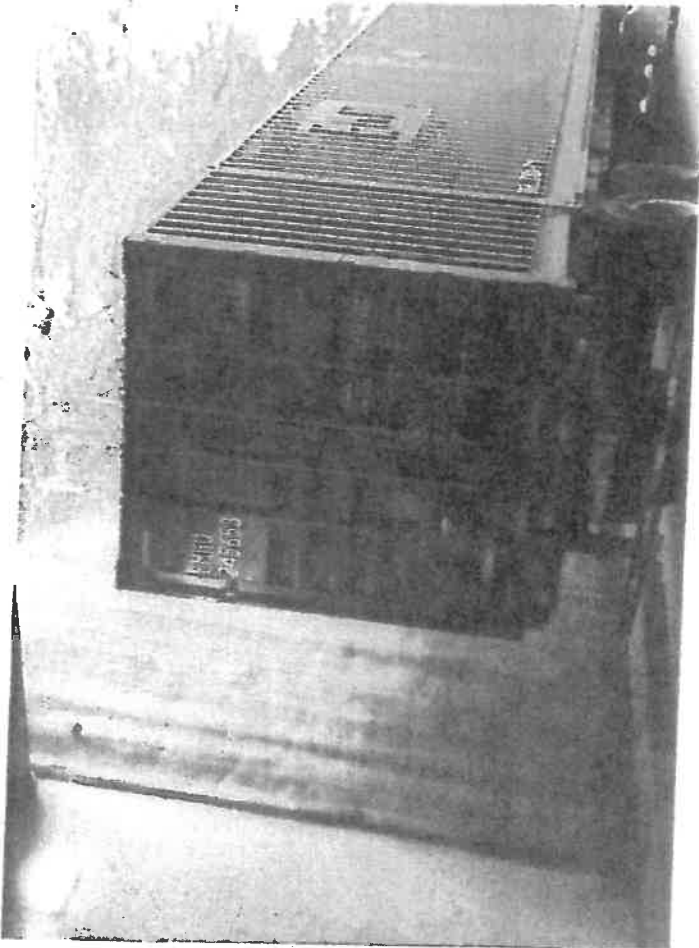

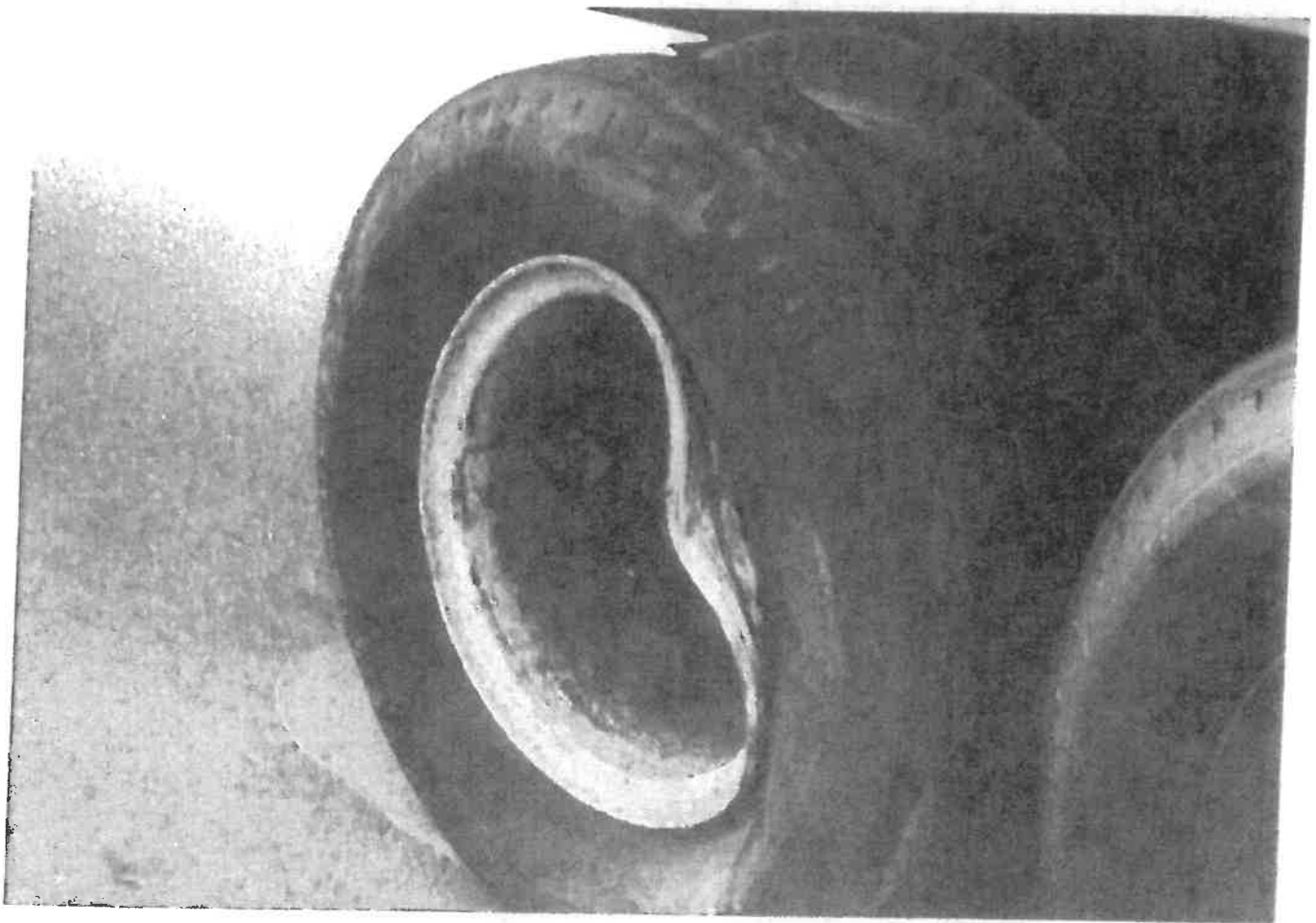

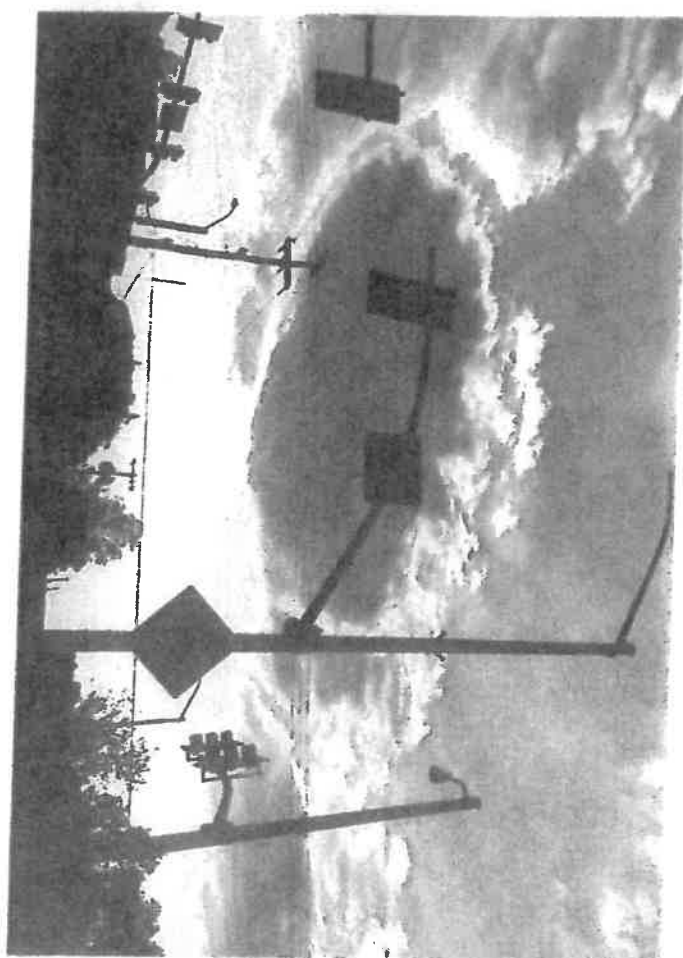
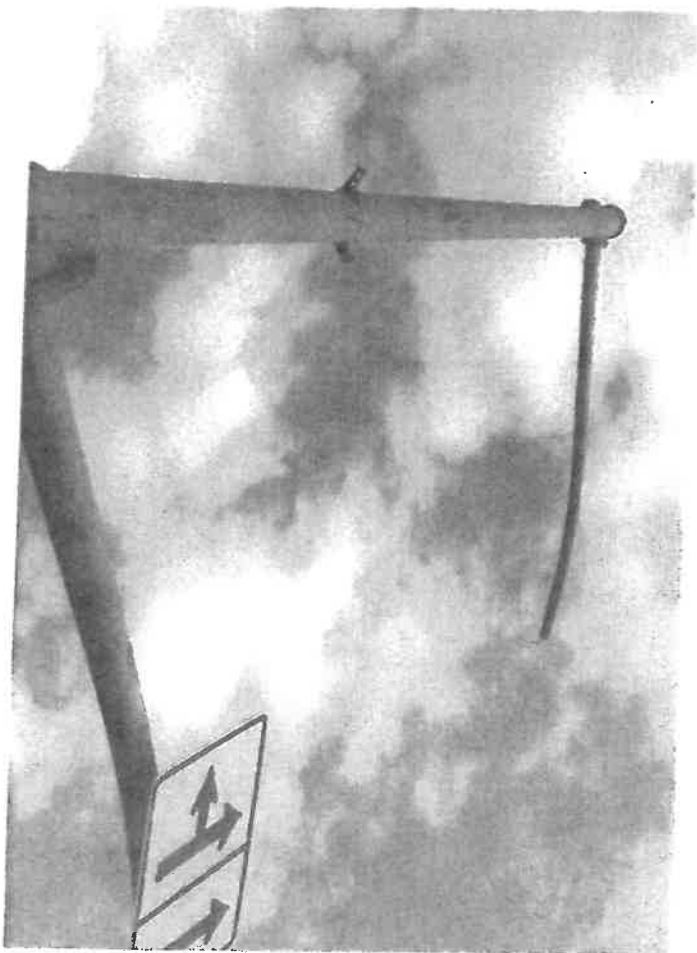
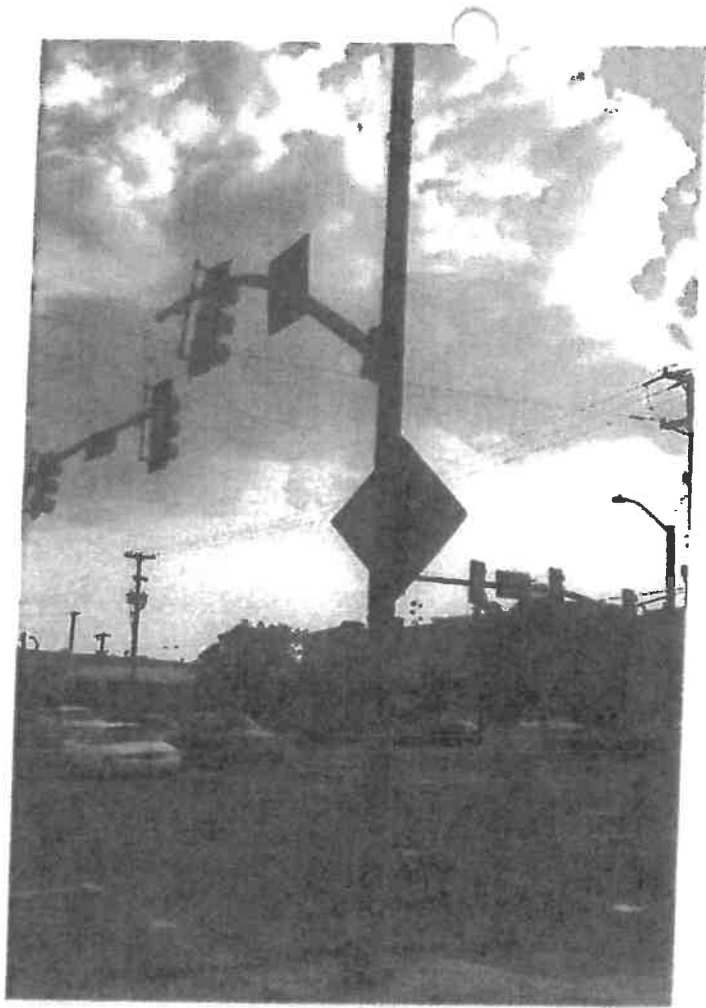

ORDINANCE OF THE CITY OF JACKSON, MISSISSIPPI ADOPTING THE 2015 EDITION OF THE INTERNATIONAL PROPERTY MAINTENANCE CODE, REGULATING AND GOVERNING THE CONDITIONS AND MAINTENANCE OF ALL PROPERTY, BUILDINGS AND STRUCTURES; BY PROVIDING THE STANDARDS FOR SUPPLIED UTILITIES AND FACILITIES AND OTHER PHYSICAL THINGS AND CONDITIONS ESSENTIAL TO ENSURE THAT STRUCTURES ARE SAFE, SANITARY AND FIT FOR OCCUPATION AND USE; AND THE CONDEMNATION OF BUILDINGS AND STRUCTURES UNFIT FOR HUMAN OCCUPANCY AND FEES THEREOF, AMENDING 26-511 ET SEQ., OF THE JACKSON, MISSISSIPPI CODE OF ORDINANCES AND REPEALING 2003-47(2) OF THE CITY OF JACKSON, MISSISSIPPI AND ALL OTHER ORDINANCES OR PARTS OF LAWS IN CONFLICT THEREWITH.

BE IT ORDAINED BY THE CITY COUNCIL OF JACKSON, MISSISSIPPI:

SECTION 1. That a certain document, three (3) copies of which are on file in Office of the City Clerk of the City of Jackson, Mississippi, being marked and designated as the International Property Maintenance Code, 2015 edition, as published by the International Code Council, be and is hereby adopted as the Property Maintenance Code of the City of Jackson, in the State of Mississippi, for regulating and governing the conditions and maintenance of all property, buildings and structure, by providing the standards for supplied utilities and facilities and other physical things and conditions essential to ensure that structures are safe, sanitary and fit for occupation and use; and the condemnation of buildings and structures unfit for human occupancy and use, and the demolition of such existing structures as herein provided, providing for the issuance of permits and collection of fees thereof; and each and all of the regulations, provisions, penalties, conditions and terms of said Property Maintenance Code on file in the Office of the City Clerk of the City of Jackson, Mississippi and hereby referred to, adopted, and made part hereof, as if fully set out in this ordinance, with the additions, insertions, deletions and changes, if any, prescribed in Section 2 of this ordinance.

SECTION 2. The following sections are hereby revised:

Section 101.1 Insert: [Name of Jurisdiction] City of Jackson, Mississippi

Section 103.1, 103.2, and 103.3 shall be omitted.

Section 103.5 Insert: [Appropriate Schedule] in accordance with the fees identified by Ordinances of the City of Jackson or other such fee schedule as may be adopted by resolution or in accordance with fines assessed by the judge.

Section 104.4 Right of entry. shall read as follows: The code official is authorized to enter the structure or premises at reasonable time to inspect subject to constitutional restrictions on unreasonable searches and seizures. Should entry be refused or not obtained, the code official is authorized to pursue recourse as provided by law.

Section 106.4. Violation penalties: shall read as follows: Any person, individual, corporation, company, partnership, association or any other entity failing to comply with this code or any of the requirements thereof or otherwise violating this code or any of the provisions shall, after notice and a reasonable time to correct said violation(s), pay a fine not exceeding One Thousand Dollars (\$1,000) or imprisonment not exceeding 90 days, or both, and each day thereafter that said violation(s) remain uncorrected shall constitute a separate offense punishable by a separate fine pursuant to Sections 21-13-1 and 21-17-5, Mississippi Code of 1972, or other statutes. The City shall impose for said violation(s) all other penalties and have access to any other remedies available under the law to correct the condition giving rise to the violations of this code.

Section 108.2.1 Authority to disconnect *water* utilities. shall read as follows: The code official shall have the authority to authorize disconnection of *water* utility service to the building, structure or system regulated by the code and the referenced codes and standards set forth in Section 102.7 in case of emergency where necessary to eliminate an immediate hazard to life or property or where such utility connection has been made without approval. The code official shall notify the serving utility and, whenever possible, the owner or owner's authorized agent and occupant of the building, structure or service system of the decision to disconnect prior to taking such action. If not notified prior to disconnection the owner, owner's authorized agent or occupant of the building structure or service system shall be notified in writing as soon as practical thereafter.

Sections 111.2, 111.2.1, 111.2.2, 111.2.3, 11.2.4, 111.2.5, and 111.3 shall be omitted.

Section 112.4 Insert: [Dollar Amount in Two Locations] double the amount of the original fee or no more than the maximum amount allowed by law.

Section 201.3 Terms defined in other codes shall read as follows: When terms are not defined in this code and are defined in the *International Building Code, International Fire Code, International Mechanical Code, International Plumbing Code, International Residential Code, Official Zoning Ordinance of the City of Jackson, Mississippi, or City of Jackson, Mississippi Code of Ordinances*, such terms shall have the meanings ascribed to them as stated in those codes.

Section 301.4 Nuisance. is hereby added and shall read as follows: The existence of any condition(s) on buildings, accessory structures, or property, which has an adverse impact on the safety, health, environment, aesthetics or property values of properties in the near vicinity as a result of being visible from outside the property, is declared to be a nuisance. Any property that is damaged or destroyed by fire or acts of nature shall be demolished or repairs must begin with three months of the damage or destruction.

Section 301.5 Hazardous Materials. is hereby added and shall read as follows: It shall be unlawful for any owner or tenant to store hazardous materials that constitute a fire or environmental hazard, or are detrimental to human life, health, or safety. Any other condition existing on or in a building, accessory structure, or property that is determined to be a safety or health hazard whether or not visible from outside the property shall be unlawful.

Section 301.6 Accumulations. is hereby added and shall read as follows: It shall be unlawful for any owner to store any item such as, but not limited to, washers, dryers, refrigerators, ovens, freezers, lawn mowers, string trimmers, edgers, tillers, rakes, shovels, other gardening supplies, toys, recliners, ice chests, boxes, crates, storage bins, storage tubs, file cabinets, grills, kennels, barrels, drums, cans, bottles, wood, metal, plastic, rags, paper, tires, auto parts; unused, inoperable, worn-out or discarded appliances or other household items; scrap iron, tin, and other metal not neatly piled, or anything whatsoever that is or may become a hazard to public health and safety, or that may harbor insect, rodent or vermin infestation on a porch, breezeway, balcony, front yard or side yard if the porch, breezeway, balcony, front yard or side yard is visible from any street.

Section 301.7 Garage or Carports. is hereby added and shall read as follows: All materials, equipment, or other items of personal property shall not be stored inside a carport to the extent that such storage prevents the use of a carport for the parking of the number of motor vehicles for which the carport is designed.

Section 302.4 Insert: [Height in Inches] 18 inches

Section 302.4.1 Vegetation Exemptions. is hereby added and shall read as follows: Vegetation planted and maintained for landscaping purposes or for erosion control shall be exempt from the requirements of this section. Vegetation located beyond fifty feet (50') from the back of curb or edge of pavement on a lot over one acre that is in a natural state shall be exempt from the requirements of this section.

Section 302.4.2 Vegetation on unimproved cleared lot. is hereby added and shall read as follows: Vegetation located on an unimproved, cleared lot shall be maintained to prohibit vegetation 48 inches in height.

Section 302.7 Accessory structures. shall read as follows: All accessory structures, including detached garage, fences and walls, shall be maintained, structurally sound, and in good repair. Fences and walls should be free from loose, missing, broken or rotting materials and shall have braces and supports attached or fastened in accordance with common buildings practices.

Section 302.7.1 Mailboxes. is hereby added and shall read as follows: All mailboxes shall be maintained structurally sound and in good repair, to include the box, post, and all attachments.

Section 304.13 Window, skylight and door frames. Every window, skylight, door and frame shall be kept in sound condition, good repair and weather light. No windows, doors, or building exteriors shall be covered with but not limited to, aluminum foil, cardboard, plywood, or plastic, except during construction or pending repairs not exceeding thirty (30) days. Existing screens on doors or windows shall not be torn or in need of repair or replacement.

Section 304.1.1 is hereby omitted.

Section 304.14 Insert: [Dates in Two Locations] January to December

Section 305.1.1 is hereby omitted.

Section 306.1.1 is hereby omitted.

Section 404.5 Overcrowding shall read as follows: The number of persons occupying a dwelling unit shall not create conditions that, in the opinion of the code official, endanger the life, health, safety or welfare of the occupants or neighbors. No boarding house, residential care facility, half-way house, hospice, shelter, single room occupancy hotel, or rooming house shall exceed twelve (12) persons.

Section 404.5.1 is hereby omitted.

Section 404.5.2 is hereby omitted.

Section 602.3 Insert: [Dates in Two Locations] October to March

SECTION 3. That ordinance No. 2003-47(2) of the Jackson, Mississippi Code of Ordinances entitled International Property Maintenance Code, 2003 edition, and all other ordinances or parts of ordinances in conflict herewith are hereby repealed.

SECTION 4. That if any section, subsection, sentence, clause or phrase of this legislation is, for any reason, held to be unconstitutional, such decision shall not affect the validity of the remaining portions of this ordinance. The governing authorities of the City of Jackson, Mississippi hereby declare that it would have passed this law, and each section, subsection, clause or phrase thereof, irrespective of the fact that any one or more sections, subsections, sentences, clauses or phrases be declared unconstitutional.

SECTION 5. That nothing in this legislation or in the Property Maintenance Code hereby adopted shall be construed to affect any suit or proceeding impending in any court, or any rights acquired, or liability incurred, or any causes of action acquired or existing, under any act or ordinance hereby repealed as cited in Section 3 of this law; nor shall any just or legal right or remedy of any character be lost, impaired or affected by this legislation.

SECTION 6. That the City Clerk of Jackson, Mississippi is hereby ordered and directed to cause this legislation to be published.

SECTION 7. That this law and the rules, regulations, provisions, requirements, orders and matters established and adopted hereby shall take effect and be in full force and effect 30 days from and after the date of its final passage and adoption.

Item #: _____
Agenda Date: June 27, 2017
By: Tyrone C. Hendrix
Margaret Barrett-Simon

IPMC®

2015

INTERNATIONAL CODES®

INTERNATIONAL
Property Maintenance
Code®

A Member of the International
Code Family®

2015 IPMC[®]

INTERNATIONAL
Property Maintenance Code[®]

CODE ALERT!

Subscribe now to receive critical code updates. Signup is easy!
www.iccsafe.org/2015alert



2015 International Property Maintenance Code®

First Printing: May 2014

ISBN: 978-1-60983-484-5 (soft-cover edition)

COPYRIGHT © 2014
by
INTERNATIONAL CODE COUNCIL, INC.

Date of First Publication: May 30, 2014

ALL RIGHTS RESERVED. This 2015 *International Property Maintenance Code*® is a copyrighted work owned by the International Code Council, Inc. Without advance written permission from the copyright owner, no part of this book may be reproduced, distributed or transmitted in any form or by any means, including, without limitation, electronic, optical or mechanical means (by way of example, and not limitation, photocopying or recording by or in an information storage retrieval system). For information on permission to copy material exceeding fair use, please contact: Publications, 4051 West Flossmoor Road, Country Club Hills, IL 60478. Phone 1-888-ICC-SAFE (422-7233).

Trademarks: “International Code Council,” the “International Code Council” logo and the “International Property Maintenance Code” are trademarks of the International Code Council, Inc.

PRINTED IN THE U.S.A.

PREFACE

Introduction

Internationally, code officials recognize the need for a modern, up-to-date property maintenance code governing the maintenance of existing buildings. The *International Property Maintenance Code*®, in this 2015 edition, is designed to meet this need through model code regulations that contain clear and specific property maintenance requirements with required property improvement provisions.

This 2015 edition is fully compatible with all of the *International Codes*® (I-Codes®) published by the International Code Council (ICC)®, including the *International Building Code*®, *International Energy Conservation Code*®, *International Existing Building Code*®, *International Fire Code*®, *International Fuel Gas Code*®, *International Green Construction Code*®, *International Mechanical Code*®, *ICC Performance Code*®, *International Plumbing Code*®, *International Private Sewage Disposal Code*®, *International Residential Code*®, *International Swimming Pool and Spa Code*™, *International Wildland-Urban Interface Code*® and *International Zoning Code*®.

The *International Property Maintenance Code* requirements provide many benefits, among which is the model code development process that offers an international forum for code officials and other interested parties to discuss performance and prescriptive code requirements. This forum provides an excellent arena to debate proposed revisions. This model code also encourages international consistency in the application of provisions.

Development

The first edition of the *International Property Maintenance Code* (1998) was the culmination of an effort initiated in 1996 by a code development committee appointed by ICC and consisting of representatives of the three statutory members of the International Code Council at that time, including: Building Officials and Code Administrators International, Inc. (BOCA), International Conference of Building Officials (ICBO) and Southern Building Code Congress International (SBCCI). The committee drafted a comprehensive set of regulations for existing buildings that was consistent with the existing model property maintenance codes at the time. This 2015 edition presents the code as originally issued, with changes reflected through the previous 2012 edition and further changes developed through the ICC Code Development Process through 2013. A new edition of the code is promulgated every 3 years.

This code is founded on principles intended to establish provisions consistent with the scope of a property maintenance code that adequately protects public health, safety and welfare; provisions that do not unnecessarily increase construction costs; provisions that do not restrict the use of new materials, products or methods of construction; and provisions that do not give preferential treatment to particular types or classes of materials, products or methods of construction.

Adoption

The International Code Council maintains a copyright in all of its codes and standards. Maintaining copyright allows ICC to fund its mission through sales of books, in both print and electronic formats. The *International Property Maintenance Code* is designed for adoption and use by jurisdictions that recognize and acknowledge the ICC's copyright in the code, and further acknowledge the substantial shared value of the public/private partnership for code development between jurisdictions and the ICC.

The ICC also recognizes the need for jurisdictions to make laws available to the public. All ICC codes and ICC standards, along with the laws of many jurisdictions, are available for free in a non-downloadable form on the ICC's website. Jurisdictions should contact the ICC at adoptions@icc-safe.org to learn how to adopt and distribute laws based on the *International Property Maintenance Code* in a manner that provides necessary access, while maintaining the ICC's copyright.

Maintenance

The *International Property Maintenance Code* is kept up to date through the review of proposed changes submitted by code enforcing officials, industry representatives, design professionals and other interested parties. Proposed changes are carefully considered through an open code development process in which all interested and affected parties may participate.

The contents of this work are subject to change through both the code development cycles and the governmental body that enacts the code into law. For more information regarding the code development process, contact the Codes and Standards Development Department of the International Code Council.

While the development procedure of the *International Property Maintenance Code* ensures the highest degree of care, the ICC, its members and those participating in the development of this code do not accept any liability resulting from compliance or noncompliance with the provisions because the ICC does not have the power or authority to police or enforce compliance with the contents of this code. Only the governmental body that enacts the code into law has such authority.

Code Development Committee Responsibilities (Letter Designations in Front of Section Numbers)

In each code development cycle, proposed changes to this code are considered at the Committee Action Hearings by the International Property Maintenance/Zoning Code Development Committee, whose action constitutes a recommendation to the voting membership for final action on the proposed changes. Proposed changes to a code section having a number beginning with a letter in brackets are considered by a different code development committee. For example, proposed changes to code sections that have the letter [F] in front of them (e.g., [F] 704.1) are considered by the International Fire Code Development Committee at the Committee Action Hearings.

The content of sections in this code that begin with a letter designation is maintained by another code development committee in accordance with the following:

- [A] = Administrative Code Development Committee;
- [F] = International Fire Code Development Committee;
- [P] = International Plumbing Code Development Committee;
- [BE] = IBC – Means of Egress Code Development Committee; and
- [BG] = IBC – General Code Development Committee.

For the development of the 2018 edition of the I-Codes, there will be three groups of code development committees and they will meet in separate years. Note that these are tentative groupings.

Group A Codes (Heard in 2015, Code Change Proposals Deadline: January 12, 2015)	Group B Codes (Heard in 2016, Code Change Proposals Deadline: January 11, 2016)	Group C Codes (Heard in 2017, Code Change Proposals Deadline: January 11, 2017)
International Building Code – Fire Safety (Chapters 7, 8, 9, 14, 26) – Means of Egress (Chapters 10, 11, Appendix E) – General (Chapters 2-6, 12, 27-33, Appendices A, B, C, D, K)	Administrative Provisions (Chapter 1 of all codes except IRC and IECC, administrative updates to currently referenced standards, and designated definitions)	International Green Construction Code
International Fuel Gas Code	International Building Code – Structural (Chapters 15-25, Appendices F, G, H, I, J, L, M)	
International Existing Building Code	International Energy Conservation Code	
International Mechanical Code	International Fire Code	
International Plumbing Code	International Residential Code – IRC-B (Chapters 1-10, Appendices E, F, H, J, K, L M, O, R, S, T, U)	
International Private Sewage Disposal Code	International Wildland-Urban Interface Code	
International Property Maintenance Code		
International Residential Code – IRC-Mechanical (Chapters 12-24) – IRC-Plumbing (Chapter 25-33, Appendices G, I, N, P)		
International Swimming Pool and Spa Code		
International Zoning Code		

Note: Proposed changes to the ICC Performance Code will be heard by the Code Development Committee noted in brackets [] in the text of the code.

Code change proposals submitted for code sections that have a letter designation in front of them will be heard by the respective committee responsible for such code sections. Because different committees hold code development hearings in different years, it is possible that some proposals for this code will be heard by committees in both the 2015 (Group A) and the 2016 (Group B) code development cycles.

For instance, every section of Chapter 1 of this code is designated as the responsibility of the Administrative Code Development Committee, and that committee is part of the Group B portion of the hearings. This committee will hold its code development hearings in 2016 to consider all code change proposals for Chapter 1 of this code and proposals for Chapter 1 of all I-Codes except the *International Energy Conservation Code*, *International Residential Code* and *ICC Performance Code*. Therefore, any proposals received for Chapter 1 of this code will be assigned to the Administrative Code Development Committee for consideration in 2016.

It is very important that anyone submitting code change proposals understand which code development committee is responsible for the section of the code that is the subject of the code change proposal. For further information on the code development committee responsibilities, please visit the ICC website at www.iccsafe.org/scoping.

Marginal Markings

Solid vertical lines in the margins within the body of the code indicate a technical change from the requirements of the 2012 edition. Deletion indicators in the form of an arrow (➡) are provided in the margin where an entire section, paragraph, exception or table has been deleted or an item in a list of items or a table has been deleted.

A single asterisk [*] placed in the margin indicates that text or a table has been relocated within the code. A double asterisk [**] placed in the margin indicates that the text or table immediately

following it has been relocated there from elsewhere in the code. The following table indicates such relocations in the 2015 edition of the *International Property Maintenance Code*.

2015 LOCATION	2012 LOCATION
None	None

Italicized Terms

Selected terms set forth in Chapter 2, Definitions, are italicized where they appear in code text. Such terms are not italicized where the definition set forth in Chapter 2 does not impart the intended meaning in the use of the term. The terms selected have definitions that the user should read carefully to facilitate better understanding of the code.

EFFECTIVE USE OF THE INTERNATIONAL PROPERTY MAINTENANCE CODE

The *International Property Maintenance Code* (IPMC) is a model code that regulates the minimum maintenance requirements for existing buildings.

The IPMC is a maintenance document intended to establish minimum maintenance standards for basic equipment, light, ventilation, heating, sanitation and fire safety. Responsibility is fixed among owners, operators and occupants for code compliance. The IPMC provides for the regulation and safe use of existing structures in the interest of the social and economic welfare of the community.

Arrangement and Format of the 2015 IPMC

Before applying the requirements of the IPMC it is beneficial to understand its arrangement and format. The IPMC, like other codes published by ICC, is arranged and organized to follow sequential steps that generally occur during an inspection. The IPMC is divided into eight different parts:

Chapters	Subjects
1	Administration
2	Definitions
3	General Requirements
4	Light, Ventilation and Occupancy Limitations
5	Plumbing Facilities and Fixture Requirements
6	Mechanical and Electrical Requirements
7	Fire Safety Requirements
8	Referenced Standards

The following is a chapter-by-chapter synopsis of the scope and intent of the provisions of the *International Property Maintenance Code*:

Chapter 1 Scope and Administration. This chapter contains provisions for the application, enforcement and administration of subsequent requirements of the code. In addition to establishing the scope of the code, Chapter 1 identifies which buildings and structures come under its purview. Chapter 1 is largely concerned with maintaining “due process of law” in enforcing the property maintenance criteria contained in the body of the code. Only through careful observation of the administrative provisions can the building official reasonably expect to demonstrate that “equal protection under the law” has been provided.

Chapter 2 Definitions. All terms that are defined in the code are listed alphabetically in Chapter 2. While a defined term may be used in one chapter or another, the meaning provided in Chapter 2 is applicable throughout the code.

Where understanding of a term’s definition is especially key to or necessary for understanding of a particular code provision, the term is shown in italics wherever it appears in the code. This is true only for those terms that have a meaning that is unique to the code. In other words, the generally understood meaning of a term or phrase might not be sufficient or consistent with the meaning prescribed by the code; therefore, it is essential that the code-defined meaning be known.

Guidance is provided regarding tense, gender and plurality of defined terms as well as terms not defined in this code.

Chapter 3 General Requirements. Chapter 3, “General Requirements,” is broad in scope. It includes a variety of requirements for the exterior property areas as well as the interior and exterior elements of the structure. This chapter provides requirements that are intended to maintain a minimum level of safety and sanitation for both the general public and the occupants of a structure, and to maintain a building’s structural and weather-resistance performance. Chapter 3 provides specific criteria for regulating the installation and maintenance of specific building components; maintenance requirements for vacant structures and land; requirements regulating the safety, sanitation and appearance of the interior and exterior of structures and all exterior property areas; accessory structures; vehicle storage regulations and establishes who is responsible for complying with the chapter’s provisions. This chapter also contains the requirements for swimming pools, spas and hot tubs and the requirements for protective barriers and gates in these barriers. Chapter 3 establishes the responsible parties for exterminating insects and rodents, and maintaining sanitary conditions in all types of occupancies.

Chapter 4 Light, Ventilation and Occupancy Limitations. The purpose of Chapter 4 is to set forth these requirements in the code and to establish the minimum environment for occupiable and habitable buildings, by establishing the minimum criteria for light and ventilation and identifies occupancy limitations including minimum room width and area, minimum ceiling height and restrictions to prevent overcrowding. This chapter also provides for alternative arrangements of windows and other devices to comply with the requirements for light and ventilation and prohibits certain room arrangements and occupancy uses.

Chapter 5 Plumbing Facilities and Fixture Requirements. Chapter 5 establishes the minimum criteria for the installation, maintenance and location of plumbing systems and facilities, including the water supply system, water heating appliances, sewage disposal system and related plumbing fixtures.

Sanitary and clean conditions in occupied buildings are dependent upon certain basic plumbing principles, including providing potable water to a building, providing the basic fixtures to effectively utilize that water and properly removing waste from the building. Chapter 5 establishes the minimum criteria to verify that these principles are maintained throughout the life of a building.

Chapter 6 Mechanical and Electrical Requirements. The purpose of Chapter 6 is to establish minimum performance requirements for heating, electrical and mechanical facilities and to establish minimum standards for the safety of these facilities.

This chapter establishes minimum criteria for the installation and maintenance of the following: heating and air-conditioning equipment, appliances and their supporting systems; water heating equipment, appliances and systems; cooking equipment and appliances; ventilation and exhaust equipment; gas and liquid fuel distribution piping and components; fireplaces and solid fuel-burning appliances; chimneys and vents; electrical services; lighting fixtures; electrical receptacle outlets; electrical distribution system equipment, devices and wiring; and elevators, escalators and dumb-waiters.

Chapter 7 Fire Safety Requirements. The purpose of Chapter 7 is to address those fire hazards that arise as the result of a building’s occupancy. It also provides minimum requirements for fire safety issues that are most likely to arise in older buildings.

This chapter contains requirements for means of egress in existing buildings, including path of travel, required egress width, means of egress doors and emergency escape openings.

Chapter 7 establishes the minimum requirements for fire safety facilities and fire protection systems, as these are essential fire safety systems.

Chapter 8 Referenced Standards. The code contains numerous references to standards that are used to regulate materials and methods of construction. Chapter 8 contains a comprehensive list of all standards that are referenced in the code. The standards are part of the code to the extent of the reference to the standard. Compliance with the referenced standard is necessary for compliance with this code. By providing specifically adopted standards, the construction and installation requirements necessary for compliance with the code can be readily determined. The basis for code compliance is, therefore, established and available on an equal basis to the code official, contractor, designer and owner.

Chapter 8 is organized in a manner that makes it easy to locate specific standards. It lists all of the referenced standards, alphabetically, by acronym of the promulgating agency of the standard. Each agency's standards are then listed in either alphabetical or numeric order based upon the standard identification. The list also contains the title of the standard; the edition (date) of the standard referenced; any addenda included as part of the ICC adoption; and the section or sections of this code that reference the standard.

LEGISLATION

Jurisdictions wishing to adopt the 2015 *International Property Maintenance Code* as an enforceable regulation governing existing structures and premises should ensure that certain factual information is included in the adopting legislation at the time adoption is being considered by the appropriate governmental body. The following sample adoption legislation addresses several key elements, including the information required for insertion into the code text.

SAMPLE LEGISLATION FOR ADOPTION OF THE INTERNATIONAL PROPERTY MAINTENANCE CODE ORDINANCE NO. _____

A[N] [ORDINANCE/STATUTE/REGULATION] of the [JURISDICTION] adopting the 2015 edition of the *International Property Maintenance Code*, regulating and governing the conditions and maintenance of all property, buildings and structures; by providing the standards for supplied utilities and facilities and other physical things and conditions essential to ensure that structures are safe, sanitary and fit for occupation and use; and the condemnation of buildings and structures unfit for human occupancy and use, and the demolition of such existing structures in the [JURISDICTION]; providing for the issuance of permits and collection of fees therefor; repealing [ORDINANCE/STATUTE/REGULATION] No. _____ of the [JURISDICTION] and all other ordinances or parts of laws in conflict therewith.

The [GOVERNING BODY] of the [JURISDICTION] does ordain as follows:

Section 1. That a certain document, three (3) copies of which are on file in the office of the [TITLE OF JURISDICTION'S KEEPER OF RECORDS] of [NAME OF JURISDICTION], being marked and designated as the *International Property Maintenance Code*, 2015 edition, as published by the International Code Council, be and is hereby adopted as the Property Maintenance Code of the [JURISDICTION], in the State of [STATE NAME] for regulating and governing the conditions and maintenance of all property, buildings and structures; by providing the standards for supplied utilities and facilities and other physical things and conditions essential to ensure that structures are safe, sanitary and fit for occupation and use; and the condemnation of buildings and structures unfit for human occupancy and use, and the demolition of such existing structures as herein provided; providing for the issuance of permits and collection of fees therefor; and each and all of the regulations, provisions, penalties, conditions and terms of said Property Maintenance Code on file in the office of the [JURISDICTION] are hereby referred to, adopted, and made a part hereof, as if fully set out in this legislation, with the additions, insertions, deletions and changes, if any, prescribed in Section 2 of this ordinance.

Section 2. The following sections are hereby revised:

Section 101.1. Insert: [NAME OF JURISDICTION]

Section 103.5. Insert: [APPROPRIATE SCHEDULE]

Section 112.4. Insert: [DOLLAR AMOUNT IN TWO LOCATIONS]

Section 302.4. Insert: [HEIGHT IN INCHES]

Section 304.14. Insert: [DATES IN TWO LOCATIONS]

Section 602.3. Insert: [DATES IN TWO LOCATIONS]

Section 602.4. Insert: [DATES IN TWO LOCATIONS]

Section 3. That [ORDINANCE/STATUTE/REGULATION] No. _____ of [JURISDICTION] entitled [FILL IN HERE THE COMPLETE TITLE OF THE LEGISLATION OR LAWS IN EFFECT AT THE PRESENT TIME SO THAT THEY WILL BE REPEALED BY DEFINITE MENTION] and all other ordinances or parts of laws in conflict herewith are hereby repealed.

Section 4. That if any section, subsection, sentence, clause or phrase of this legislation is, for any reason, held to be unconstitutional, such decision shall not affect the validity of the remaining portions of this ordinance. The [GOVERNING BODY] hereby declares that it would have passed this law, and each section, subsection, clause or phrase thereof, irrespective of the fact that any one or more sections, subsections, sentences, clauses and phrases be declared unconstitutional.

Section 5. That nothing in this legislation or in the Property Maintenance Code hereby adopted shall be construed to affect any suit or proceeding impending in any court, or any rights acquired, or liability incurred, or any cause or causes of action acquired

or existing, under any act or ordinance hereby repealed as cited in Section 3 of this law; nor shall any just or legal right or remedy of any character be lost, impaired or affected by this legislation.

Section 6. That the [JURISDICTION'S KEEPER OF RECORDS] is hereby ordered and directed to cause this legislation to be published. (An additional provision may be required to direct the number of times the legislation is to be published and to specify that it is to be in a newspaper in general circulation. Posting may also be required.)

Section 7. That this law and the rules, regulations, provisions, requirements, orders and matters established and adopted hereby shall take effect and be in full force and effect [TIME PERIOD] from and after the date of its final passage and adoption.

TABLE OF CONTENTS

<p>CHAPTER 1 SCOPE AND ADMINISTRATION 1</p> <p>PART 1—SCOPE AND APPLICATION. 1</p> <p>Section</p> <p>101 General 1</p> <p>102 Applicability 1</p> <p>PART 2—ADMINISTRATION AND ENFORCEMENT 2</p> <p>Section</p> <p>103 Department of Property Maintenance Inspection 2</p> <p>104 Duties and Powers of the Code Official 2</p> <p>105 Approval 2</p> <p>106 Violations 3</p> <p>107 Notices and Orders 3</p> <p>108 Unsafe Structures and Equipment 4</p> <p>109 Emergency Measures 5</p> <p>110 Demolition 6</p> <p>111 Means of Appeal 6</p> <p>112 Stop Work Order 7</p> <p>CHAPTER 2 DEFINITIONS 9</p> <p>Section</p> <p>201 General 9</p> <p>202 General Definitions 9</p> <p>CHAPTER 3 GENERAL REQUIREMENTS. 11</p> <p>Section</p> <p>301 General 11</p> <p>302 Exterior Property Areas 11</p> <p>303 Swimming Pools, Spas and Hot Tubs 11</p> <p>304 Exterior Structure 12</p> <p>305 Interior Structure 13</p> <p>306 Component Serviceability 14</p> <p>307 Handrails and Guardrails 15</p> <p>308 Rubbish and Garbage 15</p> <p>309 Pest Elimination 15</p> <p>CHAPTER 4 LIGHT, VENTILATION AND OCCUPANCY LIMITATIONS 17</p> <p>Section</p> <p>401 General 17</p>	<p>402 Light 17</p> <p>403 Ventilation 17</p> <p>404 Occupancy Limitations 17</p> <p>CHAPTER 5 PLUMBING FACILITIES AND FIXTURE REQUIREMENTS 19</p> <p>Section</p> <p>501 General 19</p> <p>502 Required Facilities 19</p> <p>503 Toilet Rooms 19</p> <p>504 Plumbing Systems and Fixtures 19</p> <p>505 Water System 19</p> <p>506 Sanitary Drainage System 20</p> <p>507 Storm Drainage 20</p> <p>CHAPTER 6 MECHANICAL AND ELECTRICAL REQUIREMENTS. 21</p> <p>Section</p> <p>601 General 21</p> <p>602 Heating Facilities 21</p> <p>603 Mechanical Equipment 21</p> <p>604 Electrical Facilities 21</p> <p>605 Electrical Equipment 22</p> <p>606 Elevators, Escalators and Dumbwaiters 22</p> <p>607 Duct Systems 23</p> <p>CHAPTER 7 FIRE SAFETY REQUIREMENTS . . . 25</p> <p>Section</p> <p>701 General 25</p> <p>702 Means of Egress 25</p> <p>703 Fire-resistance Ratings 25</p> <p>704 Fire Protection Systems 25</p> <p>CHAPTER 8 REFERENCED STANDARDS. 27</p> <p>APPENDIX A BOARDING STANDARD. 29</p> <p>Section</p> <p>A101 General 29</p> <p>A102 Materials 29</p> <p>A103 Installation 29</p> <p>A104 Referenced Standard 29</p> <p>INDEX. 31</p>
---	---

CHAPTER 1

SCOPE AND ADMINISTRATION

PART 1 — SCOPE AND APPLICATION

SECTION 101 GENERAL

[A] **101.1 Title.** These regulations shall be known as the *International Property Maintenance Code* of [NAME OF JURISDICTION], hereinafter referred to as “this code.”

[A] **101.2 Scope.** The provisions of this code shall apply to all existing residential and nonresidential structures and all existing *premises* and constitute minimum requirements and standards for *premises*, structures, equipment and facilities for light, *ventilation*, space, heating, sanitation, protection from the elements, a reasonable level of safety from fire and other hazards, and for a reasonable level of sanitary maintenance; the responsibility of *owners*, an owner’s authorized agent, *operators* and *occupants*; the *occupancy* of existing structures and *premises*, and for administration, enforcement and penalties.

[A] **101.3 Intent.** This code shall be construed to secure its expressed intent, which is to ensure public health, safety and welfare insofar as they are affected by the continued *occupancy* and maintenance of structures and *premises*. Existing structures and *premises* that do not comply with these provisions shall be altered or repaired to provide a minimum level of health and safety as required herein.

[A] **101.4 Severability.** If a section, subsection, sentence, clause or phrase of this code is, for any reason, held to be unconstitutional, such decision shall not affect the validity of the remaining portions of this code.

SECTION 102 APPLICABILITY

[A] **102.1 General.** Where there is a conflict between a general requirement and a specific requirement, the specific requirement shall govern. Where differences occur between provisions of this code and the referenced standards, the provisions of this code shall apply. Where, in a specific case, different sections of this code specify different requirements, the most restrictive shall govern.

[A] **102.2 Maintenance.** Equipment, systems, devices and safeguards required by this code or a previous regulation or code under which the structure or *premises* was constructed, altered or repaired shall be maintained in good working order. No *owner*, owner’s authorized agent, *operator* or *occupant* shall cause any service, facility, equipment or utility that is required under this section to be removed from, shut off from or discontinued for any occupied dwelling, except for such temporary interruption as necessary while repairs or alterations are in progress. The requirements of this code are not

intended to provide the basis for removal or abrogation of fire protection and safety systems and devices in existing structures. Except as otherwise specified herein, the *owner* or the *owner’s* authorized agent shall be responsible for the maintenance of buildings, structures and *premises*.

[A] **102.3 Application of other codes.** Repairs, additions or alterations to a structure, or changes of *occupancy*, shall be done in accordance with the procedures and provisions of the *International Building Code*, *International Existing Building Code*, *International Energy Conservation Code*, *International Fire Code*, *International Fuel Gas Code*, *International Mechanical Code*, *International Residential Code*, *International Plumbing Code* and NFPA 70. Nothing in this code shall be construed to cancel, modify or set aside any provision of the *International Zoning Code*.

[A] **102.4 Existing remedies.** The provisions in this code shall not be construed to abolish or impair existing remedies of the jurisdiction or its officers or agencies relating to the removal or demolition of any structure that is dangerous, unsafe and insanitary.

[A] **102.5 Workmanship.** Repairs, maintenance work, alterations or installations that are caused directly or indirectly by the enforcement of this code shall be executed and installed in a *workmanlike* manner and installed in accordance with the manufacturer’s instructions.

[A] **102.6 Historic buildings.** The provisions of this code shall not be mandatory for existing buildings or structures designated as historic buildings where such buildings or structures are judged by the *code official* to be safe and in the public interest of health, safety and welfare.

[A] **102.7 Referenced codes and standards.** The codes and standards referenced in this code shall be those that are listed in Chapter 8 and considered part of the requirements of this code to the prescribed extent of each such reference and as further regulated in Sections 102.7.1 and 102.7.2.

Exception: Where enforcement of a code provision would violate the conditions of the listing of the equipment or appliance, the conditions of the listing shall apply.

[A] **102.7.1 Conflicts.** Where conflicts occur between provisions of this code and the referenced standards, the provisions of this code shall apply.

[A] **102.7.2 Provisions in referenced codes and standards.** Where the extent of the reference to a referenced code or standard includes subject matter that is within the scope of this code, the provisions of this code, as applicable, shall take precedence over the provisions in the referenced code or standard.

[A] **102.8 Requirements not covered by code.** Requirements necessary for the strength, stability or proper operation of an existing fixture, structure or equipment, or for the pub-

SCOPE AND ADMINISTRATION

lic safety, health and general welfare, not specifically covered by this code, shall be determined by the *code official*.

[A] **102.9 Application of references.** References to chapter or section numbers, or to provisions not specifically identified by number, shall be construed to refer to such chapter, section or provision of this code.

[A] **102.10 Other laws.** The provisions of this code shall not be deemed to nullify any provisions of local, state or federal law.

PART 2 — ADMINISTRATION AND ENFORCEMENT

SECTION 103 DEPARTMENT OF PROPERTY MAINTENANCE INSPECTION

[A] **103.1 General.** The department of property maintenance inspection is hereby created and the executive official in charge thereof shall be known as the *code official*.

[A] **103.2 Appointment.** The *code official* shall be appointed by the chief appointing authority of the jurisdiction.

[A] **103.3 Deputies.** In accordance with the prescribed procedures of this jurisdiction and with the concurrence of the appointing authority, the *code official* shall have the authority to appoint a deputy(s). Such employees shall have powers as delegated by the *code official*.

[A] **103.4 Liability.** The *code official*, member of the board of appeals or employee charged with the enforcement of this code, while acting for the jurisdiction, in good faith and without malice in the discharge of the duties required by this code or other pertinent law or ordinance, shall not thereby be rendered civilly or criminally liable personally, and is hereby relieved from all personal liability for any damage accruing to persons or property as a result of an act or by reason of an act or omission in the discharge of official duties.

[A] **103.4.1 Legal defense.** Any suit or criminal complaint instituted against any officer or employee because of an act performed by that officer or employee in the lawful discharge of duties and under the provisions of this code shall be defended by the legal representative of the jurisdiction until the final termination of the proceedings. The code official or any subordinate shall not be liable for costs in an action, suit or proceeding that is instituted in pursuance of the provisions of this code.

[A] **103.5 Fees.** The fees for activities and services performed by the department in carrying out its responsibilities under this code shall be as indicated in the following schedule.

[JURISDICTION TO INSERT APPROPRIATE SCHEDULE.]

SECTION 104 DUTIES AND POWERS OF THE CODE OFFICIAL

[A] **104.1 General.** The *code official* is hereby authorized and directed to enforce the provisions of this code. The *code official* shall have the authority to render interpretations of this code and to adopt policies and procedures in order to

clarify the application of its provisions. Such interpretations, policies and procedures shall be in compliance with the intent and purpose of this code. Such policies and procedures shall not have the effect of waiving requirements specifically provided for in this code.

[A] **104.2 Inspections.** The *code official* shall make all of the required inspections, or shall accept reports of inspection by *approved* agencies or individuals. Reports of such inspections shall be in writing and be certified by a responsible officer of such *approved* agency or by the responsible individual. The *code official* is authorized to engage such expert opinion as deemed necessary to report upon unusual technical issues that arise, subject to the approval of the appointing authority.

[A] **104.3 Right of entry.** Where it is necessary to make an inspection to enforce the provisions of this code, or whenever the *code official* has reasonable cause to believe that there exists in a *structure* or upon a *premises* a condition in violation of this code, the *code official* is authorized to enter the structure or *premises* at reasonable times to inspect or perform the duties imposed by this code, provided that if such *structure* or *premises* is occupied the *code official* shall present credentials to the *occupant* and request entry. If such structure or *premises* is unoccupied, the *code official* shall first make a reasonable effort to locate the *owner*, *owner's* authorized agent or other person having charge or control of the *structure* or *premises* and request entry. If entry is refused, the *code official* shall have recourse to the remedies provided by law to secure entry.

[A] **104.4 Identification.** The *code official* shall carry proper identification when inspecting *structures* or *premises* in the performance of duties under this code.

[A] **104.5 Notices and orders.** The *code official* shall issue all necessary notices or orders to ensure compliance with this code.

[A] **104.6 Department records.** The *code official* shall keep official records of all business and activities of the department specified in the provisions of this code. Such records shall be retained in the official records for the period required for retention of public records.

SECTION 105 APPROVAL

[A] **105.1 Modifications.** Whenever there are practical difficulties involved in carrying out the provisions of this code, the *code official* shall have the authority to grant modifications for individual cases upon application of the *owner* or *owner's* authorized agent, provided the *code official* shall first find that special individual reason makes the strict letter of this code impractical, the modification is in compliance with the intent and purpose of this code and that such modification does not lessen health, life and fire safety requirements. The details of action granting modifications shall be recorded and entered in the department files.

[A] **105.2 Alternative materials, methods and equipment.** The provisions of this code are not intended to prevent the installation of any material or to prohibit any method of construction not specifically prescribed by this code, provided

that any such alternative has been *approved*. An alternative material or method of construction shall be *approved* where the *code official* finds that the proposed design is satisfactory and complies with the intent of the provisions of this code, and that the material, method or work offered is, for the purpose intended, at least the equivalent of that prescribed in this code in quality, strength, effectiveness, fire resistance, durability and safety. Where the alternative material, design or method of construction is not *approved*, the *code official* shall respond in writing, stating the reasons the alternative was not *approved*.

[A] 105.3 Required testing. Whenever there is insufficient evidence of compliance with the provisions of this code or evidence that a material or method does not conform to the requirements of this code, or in order to substantiate claims for alternative materials or methods, the *code official* shall have the authority to require tests to be made as evidence of compliance at no expense to the jurisdiction.

[A] 105.3.1 Test methods. Test methods shall be as specified in this code or by other recognized test standards. In the absence of recognized and accepted test methods, the *code official* shall be permitted to approve appropriate testing procedures performed by an *approved agency*.

[A] 105.3.2 Test reports. Reports of tests shall be retained by the *code official* for the period required for retention of public records.

[A] 105.4 Used material and equipment. The use of used materials that meet the requirements of this code for new materials is permitted. Materials, equipment and devices shall not be reused unless such elements are in good repair or have been reconditioned and tested where necessary, placed in good and proper working condition and *approved* by the *code official*.

[A] 105.5 Approved materials and equipment. Materials, equipment and devices *approved* by the *code official* shall be constructed and installed in accordance with such approval.

[A] 105.6 Research reports. Supporting data, where necessary to assist in the approval of materials or assemblies not specifically provided for in this code, shall consist of valid research reports from *approved sources*.

SECTION 106 VIOLATIONS

[A] 106.1 Unlawful acts. It shall be unlawful for a person, firm or corporation to be in conflict with or in violation of any of the provisions of this code.

[A] 106.2 Notice of violation. The *code official* shall serve a notice of violation or order in accordance with Section 107.

[A] 106.3 Prosecution of violation. Any person failing to comply with a notice of violation or order served in accordance with Section 107 shall be deemed guilty of a misdemeanor or civil infraction as determined by the local municipality, and the violation shall be deemed a *strict liability offense*. If the notice of violation is not complied with, the *code official* shall institute the appropriate proceeding at law or in equity to restrain, correct or abate such violation, or to

require the removal or termination of the unlawful *occupancy* of the structure in violation of the provisions of this code or of the order or direction made pursuant thereto. Any action taken by the authority having jurisdiction on such *premises* shall be charged against the real estate upon which the structure is located and shall be a lien upon such real estate.

[A] 106.4 Violation penalties. Any person who shall violate a provision of this code, or fail to comply therewith, or with any of the requirements thereof, shall be prosecuted within the limits provided by state or local laws. Each day that a violation continues after due notice has been served shall be deemed a separate offense.

[A] 106.5 Abatement of violation. The imposition of the penalties herein prescribed shall not preclude the legal officer of the jurisdiction from instituting appropriate action to restrain, correct or abate a violation, or to prevent illegal *occupancy* of a building, structure or *premises*, or to stop an illegal act, conduct, business or utilization of the building, structure or *premises*.

SECTION 107 NOTICES AND ORDERS

[A] 107.1 Notice to person responsible. Whenever the *code official* determines that there has been a violation of this code or has grounds to believe that a violation has occurred, notice shall be given in the manner prescribed in Sections 107.2 and 107.3 to the person responsible for the violation as specified in this code. Notices for condemnation procedures shall also comply with Section 108.3.

[A] 107.2 Form. Such notice prescribed in Section 107.1 shall be in accordance with all of the following:

1. Be in writing.
2. Include a description of the real estate sufficient for identification.
3. Include a statement of the violation or violations and why the notice is being issued.
4. Include a correction order allowing a reasonable time to make the repairs and improvements required to bring the *dwelling unit* or structure into compliance with the provisions of this code.
5. Inform the property *owner* or owner's authorized agent of the right to appeal.
6. Include a statement of the right to file a lien in accordance with Section 106.3.

[A] 107.3 Method of service. Such notice shall be deemed to be properly served if a copy thereof is:

1. Delivered personally;
2. Sent by certified or first-class mail addressed to the last known address; or
3. If the notice is returned showing that the letter was not delivered, a copy thereof shall be posted in a conspicuous place in or about the structure affected by such notice.

[A] **107.4 Unauthorized tampering.** Signs, tags or seals posted or affixed by the *code official* shall not be mutilated, destroyed or tampered with, or removed without authorization from the *code official*.

[A] **107.5 Penalties.** Penalties for noncompliance with orders and notices shall be as set forth in Section 106.4.

[A] **107.6 Transfer of ownership.** It shall be unlawful for the *owner* of any *dwelling unit* or structure who has received a compliance order or upon whom a notice of violation has been served to sell, transfer, mortgage, lease or otherwise dispose of such *dwelling unit* or structure to another until the provisions of the compliance order or notice of violation have been complied with, or until such *owner* or the *owner's* authorized agent shall first furnish the grantee, transferee, mortgagee or lessee a true copy of any compliance order or notice of violation issued by the *code official* and shall furnish to the *code official* a signed and notarized statement from the grantee, transferee, mortgagee or lessee, acknowledging the receipt of such compliance order or notice of violation and fully accepting the responsibility without condition for making the corrections or repairs required by such compliance order or notice of violation.

SECTION 108

UNSAFE STRUCTURES AND EQUIPMENT

[A] **108.1 General.** When a structure or equipment is found by the *code official* to be unsafe, or when a structure is found unfit for human *occupancy*, or is found unlawful, such structure shall be *condemned* pursuant to the provisions of this code.

[A] **108.1.1 Unsafe structures.** An unsafe structure is one that is found to be dangerous to the life, health, property or safety of the public or the *occupants* of the structure by not providing minimum safeguards to protect or warn *occupants* in the event of fire, or because such structure contains unsafe equipment or is so damaged, decayed, dilapidated, structurally unsafe or of such faulty construction or unstable foundation, that partial or complete collapse is possible.

[A] **108.1.2 Unsafe equipment.** Unsafe equipment includes any boiler, heating equipment, elevator, moving stairway, electrical wiring or device, flammable liquid containers or other equipment on the *premises* or within the structure which is in such disrepair or condition that such equipment is a hazard to life, health, property or safety of the public or *occupants* of the *premises* or structure.

[A] **108.1.3 Structure unfit for human occupancy.** A structure is unfit for human *occupancy* whenever the *code official* finds that such structure is unsafe, unlawful or, because of the degree to which the structure is in disrepair or lacks maintenance, is insanitary, vermin or rat infested, contains filth and contamination, or lacks *ventilation*, illumination, sanitary or heating facilities or other essential equipment required by this code, or because the location of the structure constitutes a hazard to the *occupants* of the structure or to the public.

[A] **108.1.4 Unlawful structure.** An unlawful structure is one found in whole or in part to be occupied by more persons than permitted under this code, or was erected, altered or occupied contrary to law.

[A] **108.1.5 Dangerous structure or premises.** For the purpose of this code, any structure or *premises* that has any or all of the conditions or defects described below shall be considered dangerous:

1. Any door, aisle, passageway, stairway, exit or other means of egress that does not conform to the *approved* building or fire code of the jurisdiction as related to the requirements for existing buildings.
2. The walking surface of any aisle, passageway, stairway, exit or other means of egress is so warped, worn loose, torn or otherwise unsafe as to not provide safe and adequate means of egress.
3. Any portion of a building, structure or appurtenance that has been damaged by fire, earthquake, wind, flood, *deterioration*, *neglect*, abandonment, vandalism or by any other cause to such an extent that it is likely to partially or completely collapse, or to become *detached* or dislodged.
4. Any portion of a building, or any member, appurtenance or ornamentation on the exterior thereof that is not of sufficient strength or stability, or is not so *anchored*, attached or fastened in place so as to be capable of resisting natural or artificial loads of one and one-half the original designed value.
5. The building or structure, or part of the building or structure, because of dilapidation, *deterioration*, decay, faulty construction, the removal or movement of some portion of the ground necessary for the support, or for any other reason, is likely to partially or completely collapse, or some portion of the foundation or underpinning of the building or structure is likely to fail or give way.
6. The building or structure, or any portion thereof, is clearly unsafe for its use and *occupancy*.
7. The building or structure is *neglected*, damaged, dilapidated, unsecured or abandoned so as to become an attractive nuisance to children who might play in the building or structure to their danger, becomes a harbor for vagrants, criminals or immoral persons, or enables persons to resort to the building or structure for committing a nuisance or an unlawful act.
8. Any building or structure has been constructed, exists or is maintained in violation of any specific requirement or prohibition applicable to such building or structure provided by the *approved* building or fire code of the jurisdiction, or of any law or ordinance to such an extent as to present either a substantial risk of fire, building collapse or any other threat to life and safety.

9. A building or structure, used or intended to be used for dwelling purposes, because of inadequate maintenance, dilapidation, decay, damage, faulty construction or arrangement, inadequate light, *ventilation*, mechanical or plumbing system, or otherwise, is determined by the *code official* to be unsanitary, unfit for human habitation or in such a condition that is likely to cause sickness or disease.
10. Any building or structure, because of a lack of sufficient or proper fire-resistance-rated construction, fire protection systems, electrical system, fuel connections, mechanical system, plumbing system or other cause, is determined by the *code official* to be a threat to life or health.
11. Any portion of a building remains on a site after the demolition or destruction of the building or structure or whenever any building or structure is abandoned so as to constitute such building or portion thereof as an attractive nuisance or hazard to the public.

[A] 108.2 Closing of vacant structures. If the structure is vacant and unfit for human habitation and *occupancy*, and is not in danger of structural collapse, the *code official* is authorized to post a placard of condemnation on the *premises* and order the structure closed up so as not to be an attractive nuisance. Upon failure of the *owner* or *owner's* authorized agent to close up the *premises* within the time specified in the order, the *code official* shall cause the *premises* to be closed and secured through any available public agency or by contract or arrangement by private persons and the cost thereof shall be charged against the real estate upon which the structure is located and shall be a lien upon such real estate and shall be collected by any other legal resource.

[A] 108.2.1 Authority to disconnect service utilities. The *code official* shall have the authority to authorize disconnection of utility service to the building, structure or system regulated by this code and the referenced codes and standards set forth in Section 102.7 in case of emergency where necessary to eliminate an immediate hazard to life or property or where such utility connection has been made without approval. The *code official* shall notify the serving utility and, whenever possible, the *owner* or *owner's* authorized agent and *occupant* of the building, structure or service system of the decision to disconnect prior to taking such action. If not notified prior to disconnection the *owner*, *owner's* authorized agent or *occupant* of the building structure or service system shall be notified in writing as soon as practical thereafter.

[A] 108.3 Notice. Whenever the *code official* has condemned a structure or equipment under the provisions of this section, notice shall be posted in a conspicuous place in or about the structure affected by such notice and served on the *owner*, *owner's* authorized agent or the person or persons responsible for the structure or equipment in accordance with Section 107.3. If the notice pertains to equipment, it shall be placed on the condemned equipment. The notice shall be in the form prescribed in Section 107.2.

[A] 108.4 Placarding. Upon failure of the *owner*, *owner's* authorized agent or person responsible to comply with the notice provisions within the time given, the *code official* shall post on the *premises* or on defective equipment a placard bearing the word "Condemned" and a statement of the penalties provided for occupying the *premises*, operating the equipment or removing the placard.

[A] 108.4.1 Placard removal. The *code official* shall remove the condemnation placard whenever the defect or defects upon which the condemnation and placarding action were based have been eliminated. Any person who defaces or removes a condemnation placard without the approval of the *code official* shall be subject to the penalties provided by this code.

[A] 108.5 Prohibited occupancy. Any occupied structure condemned and placarded by the *code official* shall be vacated as ordered by the *code official*. Any person who shall occupy a placarded *premises* or shall operate placarded equipment, and any *owner*, *owner's* authorized agent or person responsible for the *premises* who shall let anyone occupy a placarded *premises* or operate placarded equipment shall be liable for the penalties provided by this code.

[A] 108.6 Abatement methods. The *owner*, *owner's* authorized agent, *operator* or *occupant* of a building, *premises* or equipment deemed unsafe by the *code official* shall abate or cause to be abated or corrected such unsafe conditions either by repair, rehabilitation, demolition or other *approved* corrective action.

[A] 108.7 Record. The *code official* shall cause a report to be filed on an unsafe condition. The report shall state the *occupancy* of the structure and the nature of the unsafe condition.

SECTION 109 EMERGENCY MEASURES

[A] 109.1 Imminent danger. When, in the opinion of the *code official*, there is *imminent danger* of failure or collapse of a building or structure that endangers life, or when any structure or part of a structure has fallen and life is endangered by the occupation of the structure, or when there is actual or potential danger to the building *occupants* or those in the proximity of any structure because of explosives, explosive fumes or vapors or the presence of toxic fumes, gases or materials, or operation of defective or dangerous equipment, the *code official* is hereby authorized and empowered to order and require the *occupants* to vacate the *premises* forthwith. The *code official* shall cause to be posted at each entrance to such structure a notice reading as follows: "This Structure Is Unsafe and Its *Occupancy* Has Been Prohibited by the *Code Official*." It shall be unlawful for any person to enter such structure except for the purpose of securing the structure, making the required repairs, removing the hazardous condition or of demolishing the same.

[A] 109.2 Temporary safeguards. Notwithstanding other provisions of this code, whenever, in the opinion of the *code official*, there is *imminent danger* due to an unsafe condition, the *code official* shall order the necessary work to be done,

SCOPE AND ADMINISTRATION

including the boarding up of openings, to render such structure temporarily safe whether or not the legal procedure herein described has been instituted; and shall cause such other action to be taken as the *code official* deems necessary to meet such emergency.

[A] 109.3 Closing streets. When necessary for public safety, the *code official* shall temporarily close structures and close, or order the authority having jurisdiction to close, sidewalks, streets, *public ways* and places adjacent to unsafe structures, and prohibit the same from being utilized.

[A] 109.4 Emergency repairs. For the purposes of this section, the *code official* shall employ the necessary labor and materials to perform the required work as expeditiously as possible.

[A] 109.5 Costs of emergency repairs. Costs incurred in the performance of emergency work shall be paid by the jurisdiction. The legal counsel of the jurisdiction shall institute appropriate action against the *owner* of the *premises* or owner's authorized agent where the unsafe structure is or was located for the recovery of such costs.

[A] 109.6 Hearing. Any person ordered to take emergency measures shall comply with such order forthwith. Any affected person shall thereafter, upon petition directed to the appeals board, be afforded a hearing as described in this code.

SECTION 110 DEMOLITION

[A] 110.1 General. The *code official* shall order the *owner* or owner's authorized agent of any *premises* upon which is located any structure, which in the *code official's* or owner's authorized agent judgment after review is so deteriorated or dilapidated or has become so out of repair as to be dangerous, unsafe, insanitary or otherwise unfit for human habitation or occupancy, and such that it is unreasonable to repair the structure, to demolish and remove such structure; or if such structure is capable of being made safe by repairs, to repair and make safe and sanitary, or to board up and hold for future repair or to demolish and remove at the *owner's* option; or where there has been a cessation of normal construction of any structure for a period of more than two years, the *code official* shall order the *owner* or owner's authorized agent to demolish and remove such structure, or board up until future repair. Boarding the building up for future repair shall not extend beyond one year, unless *approved* by the building official.

[A] 110.2 Notices and orders. Notices and orders shall comply with Section 107.

[A] 110.3 Failure to comply. If the *owner* of a *premises* or owner's authorized agent fails to comply with a demolition order within the time prescribed, the *code official* shall cause the structure to be demolished and removed, either through an available public agency or by contract or arrangement with private persons, and the cost of such demolition and removal shall be charged against the real estate upon which the structure is located and shall be a lien upon such real estate.

[A] 110.4 Salvage materials. When any structure has been ordered demolished and removed, the governing body or other designated officer under said contract or arrangement aforesaid shall have the right to sell the salvage and valuable materials. The net proceeds of such sale, after deducting the expenses of such demolition and removal, shall be promptly remitted with a report of such sale or transaction, including the items of expense and the amounts deducted, for the person who is entitled thereto, subject to any order of a court. If such a surplus does not remain to be turned over, the report shall so state.

SECTION 111 MEANS OF APPEAL

[A] 111.1 Application for appeal. Any person directly affected by a decision of the *code official* or a notice or order issued under this code shall have the right to appeal to the board of appeals, provided that a written application for appeal is filed within 20 days after the day the decision, notice or order was served. An application for appeal shall be based on a claim that the true intent of this code or the rules legally adopted thereunder have been incorrectly interpreted, the provisions of this code do not fully apply, or the requirements of this code are adequately satisfied by other means.

[A] 111.2 Membership of board. The board of appeals shall consist of not less than three members who are qualified by experience and training to pass on matters pertaining to property maintenance and who are not employees of the jurisdiction. The *code official* shall be an ex-officio member but shall have no vote on any matter before the board. The board shall be appointed by the chief appointing authority, and shall serve staggered and overlapping terms.

[A] 111.2.1 Alternate members. The chief appointing authority shall appoint not less than two alternate members who shall be called by the board chairman to hear appeals during the absence or disqualification of a member. Alternate members shall possess the qualifications required for board membership.

[A] 111.2.2 Chairman. The board shall annually select one of its members to serve as chairman.

[A] 111.2.3 Disqualification of member. A member shall not hear an appeal in which that member has a personal, professional or financial interest.

[A] 111.2.4 Secretary. The chief administrative officer shall designate a qualified person to serve as secretary to the board. The secretary shall file a detailed record of all proceedings in the office of the chief administrative officer.

[A] 111.2.5 Compensation of members. Compensation of members shall be determined by law.

[A] 111.3 Notice of meeting. The board shall meet upon notice from the chairman, within 20 days of the filing of an appeal, or at stated periodic meetings.

[A] 111.4 Open hearing. Hearings before the board shall be open to the public. The appellant, the appellant's representa-

tive, the *code official* and any person whose interests are affected shall be given an opportunity to be heard. A quorum shall consist of a minimum of two-thirds of the board membership.

[A] **111.4.1 Procedure.** The board shall adopt and make available to the public through the secretary procedures under which a hearing will be conducted. The procedures shall not require compliance with strict rules of evidence, but shall mandate that only relevant information be received.

[A] **111.5 Postponed hearing.** When the full board is not present to hear an appeal, either the appellant or the appellant's representative shall have the right to request a postponement of the hearing.

[A] **111.6 Board decision.** The board shall modify or reverse the decision of the *code official* only by a concurring vote of a majority of the total number of appointed board members.

[A] **111.6.1 Records and copies.** The decision of the board shall be recorded. Copies shall be furnished to the appellant and to the *code official*.

[A] **111.6.2 Administration.** The *code official* shall take immediate action in accordance with the decision of the board.

[A] **111.7 Court review.** Any person, whether or not a previous party of the appeal, shall have the right to apply to the appropriate court for a writ of certiorari to correct errors of law. Application for review shall be made in the manner and time required by law following the filing of the decision in the office of the chief administrative officer.

[A] **111.8 Stays of enforcement.** Appeals of notice and orders (other than *Imminent Danger* notices) shall stay the enforcement of the notice and order until the appeal is heard by the appeals board.

SECTION 112 STOP WORK ORDER

[A] **112.1 Authority.** Whenever the *code official* finds any work regulated by this code being performed in a manner contrary to the provisions of this code or in a dangerous or unsafe manner, the *code official* is authorized to issue a stop work order.

[A] **112.2 Issuance.** A stop work order shall be in writing and shall be given to the *owner* of the property, to the *owner's* authorized agent, or to the person doing the work. Upon issuance of a stop work order, the cited work shall immediately cease. The stop work order shall state the reason for the order and the conditions under which the cited work is authorized to resume.

[A] **112.3 Emergencies.** Where an emergency exists, the *code official* shall not be required to give a written notice prior to stopping the work.

[A] **112.4 Failure to comply.** Any person who shall continue any work after having been served with a stop work order, except such work as that person is directed to perform to

remove a violation or unsafe condition, shall be liable to a fine of not less than [AMOUNT] dollars or more than [AMOUNT] dollars.

CHAPTER 2

DEFINITIONS

SECTION 201 GENERAL

201.1 Scope. Unless otherwise expressly stated, the following terms shall, for the purposes of this code, have the meanings shown in this chapter.

201.2 Interchangeability. Words stated in the present tense include the future; words stated in the masculine gender include the feminine and neuter; the singular number includes the plural and the plural, the singular.

201.3 Terms defined in other codes. Where terms are not defined in this code and are defined in the *International Building Code*, *International Existing Building Code*, *International Fire Code*, *International Fuel Gas Code*, *International Mechanical Code*, *International Plumbing Code*, *International Residential Code*, *International Zoning Code* or NFPA 70, such terms shall have the meanings ascribed to them as stated in those codes.

201.4 Terms not defined. Where terms are not defined through the methods authorized by this section, such terms shall have ordinarily accepted meanings such as the context implies.

201.5 Parts. Whenever the words “*dwelling unit*,” “*dwelling*,” “*premises*,” “*building*,” “*rooming house*,” “*rooming unit*,” “*housekeeping unit*” or “*story*” are stated in this code, they shall be construed as though they were followed by the words “or any part thereof.”

SECTION 202 GENERAL DEFINITIONS

ANCHORED. Secured in a manner that provides positive connection.

[A] APPROVED. Acceptable to the *code official*.

BASEMENT. That portion of a building which is partly or completely below grade.

BATHROOM. A room containing plumbing fixtures including a bathtub or shower.

BEDROOM. Any room or space used or intended to be used for sleeping purposes in either a dwelling or *sleeping unit*.

[A] CODE OFFICIAL. The official who is charged with the administration and enforcement of this code, or any duly authorized representative.

CONDEMN. To adjudge unfit for *occupancy*.

COST OF SUCH DEMOLITION OR EMERGENCY REPAIRS. The costs shall include the actual costs of the demolition or repair of the structure less revenues obtained if salvage was conducted prior to demolition or repair. Costs shall include, but not be limited to, expenses incurred or necessitated related to demolition or emergency repairs, such

as asbestos survey and abatement if necessary; costs of inspectors, testing agencies or experts retained relative to the demolition or emergency repairs; costs of testing; surveys for other materials that are controlled or regulated from being dumped in a landfill; title searches; mailing(s); postings; recording; and attorney fees expended for recovering of the cost of emergency repairs or to obtain or enforce an order of demolition made by a *code official*, the governing body or board of appeals.

DETACHED. When a structural element is physically disconnected from another and that connection is necessary to provide a positive connection.

DETERIORATION. To weaken, disintegrate, corrode, rust or decay and lose effectiveness.

[BG] DWELLING UNIT. A single unit providing complete, independent living facilities for one or more persons, including permanent provisions for living, sleeping, eating, cooking and sanitation.

[Z] EASEMENT. That portion of land or property reserved for present or future use by a person or agency other than the legal fee *owner(s)* of the property. The *easement* shall be permitted to be for use under, on or above a said lot or lots.

EQUIPMENT SUPPORT. Those structural members or assemblies of members or manufactured elements, including braces, frames, lugs, snuggers, hangers or saddles, that transmit gravity load, lateral load and operating load between the equipment and the structure.

EXTERIOR PROPERTY. The open space on the *premises* and on adjoining property under the control of *owners* or *operators* of such *premises*.

GARBAGE. The animal or vegetable waste resulting from the handling, preparation, cooking and consumption of food.

[BE] GUARD. A building component or a system of building components located at or near the open sides of elevated walking surfaces that minimizes the possibility of a fall from the walking surface to a lower level.

[BG] HABITABLE SPACE. Space in a structure for living, sleeping, eating or cooking. *Bathrooms*, *toilet rooms*, closets, halls, storage or utility spaces, and similar areas are not considered *habitable spaces*.

HISTORIC BUILDING. Any building or structure that is one or more of the following:

1. Listed or certified as eligible for listing, by the State Historic Preservation Officer or the Keeper of the National Register of Historic Places, in the National Register of Historic Places.
2. Designated as historic under an applicable state or local law.

DEFINITIONS

3. Certified as a contributing resource within a National Register or state or locally designated historic district.

HOUSEKEEPING UNIT. A room or group of rooms forming a single *habitable space* equipped and intended to be used for living, sleeping, cooking and eating which does not contain, within such a unit, a toilet, lavatory and bathtub or shower.

IMMINENT DANGER. A condition which could cause serious or life-threatening injury or death at any time.

INFESTATION. The presence, within or contiguous to, a structure or *premises* of insects, rats, vermin or other pests.

INOPERABLE MOTOR VEHICLE. A vehicle which cannot be driven upon the public streets for reason including but not limited to being unlicensed, wrecked, abandoned, in a state of disrepair, or incapable of being moved under its own power.

[A] LABELED. Equipment, materials or products to which have been affixed a label, seal, symbol or other identifying mark of a nationally recognized testing laboratory, inspection agency or other organization concerned with product evaluation that maintains periodic inspection of the production of the above-labeled items and whose labeling indicates either that the equipment, material or product meets identified standards or has been tested and found suitable for a specified purpose.

LET FOR OCCUPANCY or LET. To permit, provide or offer possession or *occupancy* of a dwelling, *dwelling unit*, *rooming unit*, building, premise or structure by a person who is or is not the legal *owner* of record thereof, pursuant to a written or unwritten lease, agreement or license, or pursuant to a recorded or unrecorded agreement of contract for the sale of land.

NEGLECT. The lack of proper maintenance for a building or *structure*.

[A] OCCUPANCY. The purpose for which a building or portion thereof is utilized or occupied.

OCCUPANT. Any individual living or sleeping in a building, or having possession of a space within a building.

OPENABLE AREA. That part of a window, skylight or door which is available for unobstructed *ventilation* and which opens directly to the outdoors.

OPERATOR. Any person who has charge, care or control of a structure or *premises* which is let or offered for *occupancy*.

[A] OWNER. Any person, agent, *operator*, firm or corporation having legal or equitable interest in the property; or recorded in the official records of the state, county or municipality as holding title to the property; or otherwise having control of the property, including the guardian of the estate of any such person, and the executor or administrator of the estate of such person if ordered to take possession of real property by a court.

PERSON. An individual, corporation, partnership or any other group acting as a unit.

PEST ELIMINATION. The control and elimination of insects, rodents or other pests by eliminating their harborage places; by removing or making inaccessible materials that serve as their food or water; by other *approved pest elimination* methods.

[A] PREMISES. A lot, plot or parcel of land, *easement* or *public way*, including any structures thereon.

[A] PUBLIC WAY. Any street, alley or similar parcel of land essentially unobstructed from the ground to the sky, which is deeded, dedicated or otherwise permanently appropriated to the public for public use.

ROOMING HOUSE. A building arranged or occupied for lodging, with or without meals, for compensation and not occupied as a one- or two-family dwelling.

ROOMING UNIT. Any room or group of rooms forming a single habitable unit occupied or intended to be occupied for sleeping or living, but not for cooking purposes.

RUBBISH. Combustible and noncombustible waste materials, except garbage; the term shall include the residue from the burning of wood, coal, coke and other combustible materials, paper, rags, cartons, boxes, wood, excelsior, rubber, leather, tree branches, *yard* trimmings, tin cans, metals, mineral matter, glass, crockery and dust and other similar materials.

[BG] SLEEPING UNIT. A room or space in which people sleep, which can also include permanent provisions for living, eating and either sanitation or kitchen facilities, but not both. Such rooms and spaces that are also part of a *dwelling unit* are not *sleeping units*.

STRICT LIABILITY OFFENSE. An offense in which the prosecution in a legal proceeding is not required to prove criminal intent as a part of its case. It is enough to prove that the defendant either did an act which was prohibited, or failed to do an act which the defendant was legally required to do.

[A] STRUCTURE. That which is built or constructed or a portion thereof.

TENANT. A person, corporation, partnership or group, whether or not the legal *owner* of record, occupying a building or portion thereof as a unit.

TOILET ROOM. A room containing a water closet or urinal but not a bathtub or shower.

ULTIMATE DEFORMATION. The deformation at which failure occurs and which shall be deemed to occur if the sustainable load reduces to 80 percent or less of the maximum strength.

[M] VENTILATION. The natural or mechanical process of supplying conditioned or unconditioned air to, or removing such air from, any space.

WORKMANLIKE. Executed in a skilled manner; e.g., generally plumb, level, square, in line, undamaged and without marring adjacent work.

[Z] YARD. An open space on the same lot with a structure.

CHAPTER 3

GENERAL REQUIREMENTS

SECTION 301 GENERAL

301.1 Scope. The provisions of this chapter shall govern the minimum conditions and the responsibilities of persons for maintenance of structures, equipment and *exterior property*.

301.2 Responsibility. The *owner* of the *premises* shall maintain the structures and *exterior property* in compliance with these requirements, except as otherwise provided for in this code. A person shall not occupy as owner-occupant or permit another person to occupy *premises* that are not in a sanitary and safe condition and that do not comply with the requirements of this chapter. *Occupants* of a *dwelling unit, rooming unit or housekeeping unit* are responsible for keeping in a clean, sanitary and safe condition that part of the *dwelling unit, rooming unit, housekeeping unit or premises* which they occupy and control.

301.3 Vacant structures and land. Vacant structures and *premises* thereof or vacant land shall be maintained in a clean, safe, secure and sanitary condition as provided herein so as not to cause a blighting problem or adversely affect the public health or safety.

SECTION 302 EXTERIOR PROPERTY AREAS

302.1 Sanitation. *Exterior property* and *premises* shall be maintained in a clean, safe and sanitary condition. The *occupant* shall keep that part of the *exterior property* that such *occupant* occupies or controls in a clean and sanitary condition.

302.2 Grading and drainage. *Premises* shall be graded and maintained to prevent the erosion of soil and to prevent the accumulation of stagnant water thereon, or within any structure located thereon.

Exception: *Approved* retention areas and reservoirs.

302.3 Sidewalks and driveways. Sidewalks, walkways, stairs, driveways, parking spaces and similar areas shall be kept in a proper state of repair, and maintained free from hazardous conditions.

302.4 Weeds. *Premises* and *exterior property* shall be maintained free from weeds or plant growth in excess of [JURISDICTION TO INSERT HEIGHT IN INCHES]. Noxious weeds shall be prohibited. Weeds shall be defined as all grasses, annual plants and vegetation, other than trees or shrubs provided; however, this term shall not include cultivated flowers and gardens.

Upon failure of the *owner* or agent having charge of a property to cut and destroy weeds after service of a notice of violation, they shall be subject to prosecution in accordance with Section 106.3 and as prescribed by the authority having jurisdiction. Upon failure to comply with the notice of viola-

tion, any duly authorized employee of the jurisdiction or contractor hired by the jurisdiction shall be authorized to enter upon the property in violation and cut and destroy the weeds growing thereon, and the costs of such removal shall be paid by the *owner* or agent responsible for the property.

302.5 Rodent harborage. Structures and *exterior property* shall be kept free from rodent harborage and *infestation*. Where rodents are found, they shall be promptly exterminated by *approved* processes that will not be injurious to human health. After pest elimination, proper precautions shall be taken to eliminate rodent harborage and prevent reinfestation.

302.6 Exhaust vents. Pipes, ducts, conductors, fans or blowers shall not discharge gases, steam, vapor, hot air, grease, smoke, odors or other gaseous or particulate wastes directly upon abutting or adjacent public or private property or that of another *tenant*.

302.7 Accessory structures. Accessory structures, including *detached* garages, fences and walls, shall be maintained structurally sound and in good repair.

302.8 Motor vehicles. Except as provided for in other regulations, no inoperative or unlicensed motor vehicle shall be parked, kept or stored on any *premises*, and no vehicle shall at any time be in a state of major disassembly, disrepair, or in the process of being stripped or dismantled. Painting of vehicles is prohibited unless conducted inside an *approved* spray booth.

Exception: A vehicle of any type is permitted to undergo major overhaul, including body work, provided that such work is performed inside a structure or similarly enclosed area designed and *approved* for such purposes.

302.9 Defacement of property. No person shall willfully or wantonly damage, mutilate or deface any exterior surface of any structure or building on any private or public property by placing thereon any marking, carving or graffiti.

It shall be the responsibility of the *owner* to restore said surface to an *approved* state of maintenance and repair.

SECTION 303 SWIMMING POOLS, SPAS AND HOT TUBS

303.1 Swimming pools. Swimming pools shall be maintained in a clean and sanitary condition, and in good repair.

303.2 Enclosures. Private swimming pools, hot tubs and spas, containing water more than 24 inches (610 mm) in depth shall be completely surrounded by a fence or barrier not less than 48 inches (1219 mm) in height above the finished ground level measured on the side of the barrier away from the pool. Gates and doors in such barriers shall be self-closing and self-latching. Where the self-latching device is not less than 54 inches (1372 mm) above the bottom of the

GENERAL REQUIREMENTS

gate, the release mechanism shall be located on the pool side of the gate. Self-closing and self-latching gates shall be maintained such that the gate will positively close and latch when released from an open position of 6 inches (152 mm) from the gatepost. No existing pool enclosure shall be removed, replaced or changed in a manner that reduces its effectiveness as a safety barrier.

Exception: Spas or hot tubs with a safety cover that complies with ASTM F 1346 shall be exempt from the provisions of this section.

SECTION 304 EXTERIOR STRUCTURE

304.1 General. The exterior of a structure shall be maintained in good repair, structurally sound and sanitary so as not to pose a threat to the public health, safety or welfare.

304.1.1 Unsafe conditions. The following conditions shall be determined as unsafe and shall be repaired or replaced to comply with the *International Building Code* or the *International Existing Building Code* as required for existing buildings:

1. The nominal strength of any structural member is exceeded by nominal loads, the load effects or the required strength;
2. The *anchorage* of the floor or roof to walls or columns, and of walls and columns to foundations is not capable of resisting all nominal loads or load effects;
3. Structures or components thereof that have reached their limit state;
4. Siding and masonry joints including joints between the building envelope and the perimeter of windows, doors and skylights are not maintained, weather resistant or water tight;
5. Structural members that have evidence of *deterioration* or that are not capable of safely supporting all nominal loads and load effects;
6. Foundation systems that are not firmly supported by footings, are not plumb and free from open cracks and breaks, are not properly *anchored* or are not capable of supporting all nominal loads and resisting all load effects;
7. Exterior walls that are not *anchored* to supporting and supported elements or are not plumb and free of holes, cracks or breaks and loose or rotting materials, are not properly *anchored* or are not capable of supporting all nominal loads and resisting all load effects;
8. Roofing or roofing components that have defects that admit rain, roof surfaces with inadequate drainage, or any portion of the roof framing that is not in good repair with signs of *deterioration*, fatigue or without proper anchorage and incapable of supporting all nominal loads and resisting all load effects;
9. Flooring and flooring components with defects that affect serviceability or flooring components that show signs of *deterioration* or fatigue, are not properly *anchored* or are incapable of supporting all nominal loads and resisting all load effects;
10. Veneer, cornices, belt courses, corbels, trim, wall facings and similar decorative features not properly anchored or that are anchored with connections not capable of supporting all nominal loads and resisting all load effects;
11. Overhang extensions or projections including, but not limited to, trash chutes, canopies, marquees, signs, awnings, fire escapes, standpipes and exhaust ducts not properly *anchored* or that are *anchored* with connections not capable of supporting all nominal loads and resisting all load effects;
12. Exterior stairs, decks, porches, balconies and all similar appurtenances attached thereto, including *guards* and handrails, are not structurally sound, not properly *anchored* or that are *anchored* with connections not capable of supporting all nominal loads and resisting all load effects; or
13. Chimneys, cooling towers, smokestacks and similar appurtenances not structurally sound or not properly *anchored*, or that are anchored with connections not capable of supporting all nominal loads and resisting all load effects.

Exceptions:

1. Where substantiated otherwise by an *approved* method.
2. Demolition of unsafe conditions shall be permitted where *approved* by the *code official*.

304.2 Protective treatment. Exterior surfaces, including but not limited to, doors, door and window frames, cornices, porches, trim, balconies, decks and fences, shall be maintained in good condition. Exterior wood surfaces, other than decay-resistant woods, shall be protected from the elements and decay by painting or other protective covering or treatment. Peeling, flaking and chipped paint shall be eliminated and surfaces repainted. Siding and masonry joints, as well as those between the building envelope and the perimeter of windows, doors and skylights, shall be maintained weather resistant and water tight. Metal surfaces subject to rust or corrosion shall be coated to inhibit such rust and corrosion, and surfaces with rust or corrosion shall be stabilized and coated to inhibit future rust and corrosion. Oxidation stains shall be removed from exterior surfaces. Surfaces designed for stabilization by oxidation are exempt from this requirement.

[F] 304.3 Premises identification. Buildings shall have *approved* address numbers placed in a position to be plainly legible and visible from the street or road fronting the property. These numbers shall contrast with their background. Address numbers shall be Arabic numerals or alphabet letters. Numbers shall be not less than 4 inches (102 mm) in height with a minimum stroke width of 0.5 inch (12.7 mm).

304.4 Structural members. Structural members shall be maintained free from *deterioration*, and shall be capable of safely supporting the imposed dead and live loads.

304.5 Foundation walls. Foundation walls shall be maintained plumb and free from open cracks and breaks and shall be kept in such condition so as to prevent the entry of rodents and other pests.

304.6 Exterior walls. Exterior walls shall be free from holes, breaks, and loose or rotting materials; and maintained weatherproof and properly surface coated where required to prevent *deterioration*.

304.7 Roofs and drainage. The roof and flashing shall be sound, tight and not have defects that admit rain. Roof drainage shall be adequate to prevent dampness or *deterioration* in the walls or interior portion of the structure. Roof drains, gutters and downspouts shall be maintained in good repair and free from obstructions. Roof water shall not be discharged in a manner that creates a public nuisance.

304.8 Decorative features. Cornices, belt courses, corbels, terra cotta trim, wall facings and similar decorative features shall be maintained in good repair with proper anchorage and in a safe condition.

304.9 Overhang extensions. Overhang extensions including, but not limited to, canopies, marquees, signs, metal awnings, fire escapes, standpipes and exhaust ducts shall be maintained in good repair and be properly *anchored* so as to be kept in a sound condition. Where required, all exposed surfaces of metal or wood shall be protected from the elements and against decay or rust by periodic application of weather-coating materials, such as paint or similar surface treatment.

304.10 Stairways, decks, porches and balconies. Every exterior stairway, deck, porch and balcony, and all appurtenances attached thereto, shall be maintained structurally sound, in good repair, with proper anchorage and capable of supporting the imposed loads.

304.11 Chimneys and towers. Chimneys, cooling towers, smoke stacks, and similar appurtenances shall be maintained structurally safe and sound, and in good repair. Exposed surfaces of metal or wood shall be protected from the elements and against decay or rust by periodic application of weather-coating materials, such as paint or similar surface treatment.

304.12 Handrails and guards. Every handrail and *guard* shall be firmly fastened and capable of supporting normally imposed loads and shall be maintained in good condition.

304.13 Window, skylight and door frames. Every window, skylight, door and frame shall be kept in sound condition, good repair and weather tight.

304.13.1 Glazing. Glazing materials shall be maintained free from cracks and holes.

304.13.2 Openable windows. Every window, other than a fixed window, shall be easily openable and capable of being held in position by window hardware.

304.14 Insect screens. During the period from [DATE] to [DATE], every door, window and other outside opening required for *ventilation* of habitable rooms, food preparation areas, food service areas or any areas where products to be

included or utilized in food for human consumption are processed, manufactured, packaged or stored shall be supplied with *approved* tightly fitting screens of minimum 16 mesh per inch (16 mesh per 25 mm), and every screen door used for insect control shall have a self-closing device in good working condition.

Exception: Screens shall not be required where other *approved* means, such as air curtains or insect repellent fans, are employed.

304.15 Doors. Exterior doors, door assemblies, operator systems if provided, and hardware shall be maintained in good condition. Locks at all entrances to dwelling units and sleeping units shall tightly secure the door. Locks on means of egress doors shall be in accordance with Section 702.3.

304.16 Basement hatchways. Every *basement* hatchway shall be maintained to prevent the entrance of rodents, rain and surface drainage water.

304.17 Guards for basement windows. Every *basement* window that is openable shall be supplied with rodent shields, storm windows or other *approved* protection against the entry of rodents.

304.18 Building security. Doors, windows or hatchways for *dwelling units*, room units or *housekeeping units* shall be provided with devices designed to provide security for the *occupants* and property within.

304.18.1 Doors. Doors providing access to a *dwelling unit*, *rooming unit* or *housekeeping unit* that is rented, leased or let shall be equipped with a deadbolt lock designed to be readily openable from the side from which egress is to be made without the need for keys, special knowledge or effort and shall have a minimum lock throw of 1 inch (25 mm). Such deadbolt locks shall be installed according to the manufacturer's specifications and maintained in good working order. For the purpose of this section, a sliding bolt shall not be considered an acceptable deadbolt lock.

304.18.2 Windows. Operable windows located in whole or in part within 6 feet (1828 mm) above ground level or a walking surface below that provide access to a *dwelling unit*, *rooming unit* or *housekeeping unit* that is rented, leased or let shall be equipped with a window sash locking device.

304.18.3 Basement hatchways. *Basement* hatchways that provide access to a *dwelling unit*, *rooming unit* or *housekeeping unit* that is rented, leased or let shall be equipped with devices that secure the units from unauthorized entry.

304.19 Gates. Exterior gates, gate assemblies, operator systems if provided, and hardware shall be maintained in good condition. Latches at all entrances shall tightly secure the gates.

SECTION 305 INTERIOR STRUCTURE

305.1 General. The interior of a structure and equipment therein shall be maintained in good repair, structurally sound and in a sanitary condition. *Occupants* shall keep that part of

GENERAL REQUIREMENTS

the structure that they occupy or control in a clean and sanitary condition. Every *owner* of a structure containing a *rooming house, housekeeping units, a hotel, a dormitory, two or more dwelling units* or two or more nonresidential occupancies, shall maintain, in a clean and sanitary condition, the shared or public areas of the structure and *exterior property*.

305.1.1 Unsafe conditions. The following conditions shall be determined as unsafe and shall be repaired or replaced to comply with the *International Building Code* or the *International Existing Building Code* as required for existing buildings:

1. The nominal strength of any structural member is exceeded by nominal loads, the load effects or the required strength;
2. The anchorage of the floor or roof to walls or columns, and of walls and columns to foundations is not capable of resisting all nominal loads or load effects;
3. Structures or components thereof that have reached their limit state;
4. Structural members are incapable of supporting nominal loads and load effects;
5. Stairs, landings, balconies and all similar walking surfaces, including *guards* and handrails, are not structurally sound, not properly *anchored* or are *anchored* with connections not capable of supporting all nominal loads and resisting all load effects;
6. Foundation systems that are not firmly supported by footings are not plumb and free from open cracks and breaks, are not properly *anchored* or are not capable of supporting all nominal loads and resisting all load effects.

Exceptions:

1. Where substantiated otherwise by an *approved* method.
2. Demolition of unsafe conditions shall be permitted when *approved* by the *code official*.

305.2 Structural members. Structural members shall be maintained structurally sound, and be capable of supporting the imposed loads.

305.3 Interior surfaces. Interior surfaces, including windows and doors, shall be maintained in good, clean and sanitary condition. Peeling, chipping, flaking or abraded paint shall be repaired, removed or covered. Cracked or loose plaster, decayed wood and other defective surface conditions shall be corrected.

305.4 Stairs and walking surfaces. Every stair, ramp, landing, balcony, porch, deck or other walking surface shall be maintained in sound condition and good repair.

305.5 Handrails and guards. Every handrail and *guard* shall be firmly fastened and capable of supporting normally imposed loads and shall be maintained in good condition.

305.6 Interior doors. Every interior door shall fit reasonably well within its frame and shall be capable of being opened and closed by being properly and securely attached to jambs,

headers or tracks as intended by the manufacturer of the attachment hardware.

SECTION 306 COMPONENT SERVICEABILITY

306.1 General. The components of a structure and equipment therein shall be maintained in good repair, structurally sound and in a sanitary condition.

306.1.1 Unsafe conditions. Where any of the following conditions cause the component or system to be beyond its limit state, the component or system shall be determined as unsafe and shall be repaired or replaced to comply with the *International Building Code* or the *International Existing Building Code* as required for existing buildings:

1. Soils that have been subjected to any of the following conditions:
 - 1.1. Collapse of footing or foundation system;
 - 1.2. Damage to footing, foundation, concrete or other structural element due to soil expansion;
 - 1.3. Adverse effects to the design strength of footing, foundation, concrete or other structural element due to a chemical reaction from the soil;
 - 1.4. Inadequate soil as determined by a geotechnical investigation;
 - 1.5. Where the allowable bearing capacity of the soil is in doubt; or
 - 1.6. Adverse effects to the footing, foundation, concrete or other structural element due to the ground water table.
2. Concrete that has been subjected to any of the following conditions:
 - 2.1. *Deterioration*;
 - 2.2. *Ultimate deformation*;
 - 2.3. Fractures;
 - 2.4. Fissures;
 - 2.5. Spalling;
 - 2.6. Exposed reinforcement; or
 - 2.7. *Detached*, dislodged or failing connections.
3. Aluminum that has been subjected to any of the following conditions:
 - 3.1. *Deterioration*;
 - 3.2. Corrosion;
 - 3.3. Elastic deformation;
 - 3.4. *Ultimate deformation*;
 - 3.5. Stress or strain cracks;
 - 3.6. Joint fatigue; or
 - 3.7. *Detached*, dislodged or failing connections.

4. Masonry that has been subjected to any of the following conditions:
 - 4.1. *Deterioration*;
 - 4.2. *Ultimate deformation*;
 - 4.3. Fractures in masonry or mortar joints;
 - 4.4. Fissures in masonry or mortar joints;
 - 4.5. Spalling;
 - 4.6. Exposed reinforcement; or
 - 4.7. *Detached*, dislodged or failing connections.
5. Steel that has been subjected to any of the following conditions:
 - 5.1. *Deterioration*;
 - 5.2. Elastic deformation;
 - 5.3. *Ultimate deformation*;
 - 5.4. Metal fatigue; or
 - 5.5. *Detached*, dislodged or failing connections.
6. Wood that has been subjected to any of the following conditions:
 - 6.1. *Ultimate deformation*;
 - 6.2. *Deterioration*;
 - 6.3. Damage from insects, rodents and other vermin;
 - 6.4. Fire damage beyond charring;
 - 6.5. Significant splits and checks;
 - 6.6. Horizontal shear cracks;
 - 6.7. Vertical shear cracks;
 - 6.8. Inadequate support;
 - 6.9. *Detached*, dislodged or failing connections; or
 - 6.10. Excessive cutting and notching.

Exceptions:

1. Where substantiated otherwise by an *approved* method.
2. Demolition of unsafe conditions shall be permitted where *approved* by the *code official*.

SECTION 307 HANDRAILS AND GUARDRAILS

307.1 General. Every exterior and interior flight of stairs having more than four risers shall have a handrail on one side of the stair and every open portion of a stair, landing, balcony, porch, deck, ramp or other walking surface that is more than 30 inches (762 mm) above the floor or grade below shall have *guards*. Handrails shall be not less than 30 inches (762 mm) in height or more than 42 inches (1067 mm) in height measured vertically above the nosing of the tread or above the finished floor of the landing or walking surfaces. *Guards* shall be not less than 30 inches (762 mm) in height above the

floor of the landing, balcony, porch, deck, or ramp or other walking surface.

Exception: *Guards* shall not be required where exempted by the adopted building code.

SECTION 308 RUBBISH AND GARBAGE

308.1 Accumulation of rubbish or garbage. *Exterior property* and *premises*, and the interior of every structure, shall be free from any accumulation of *rubbish* or garbage.

308.2 Disposal of rubbish. Every *occupant* of a structure shall dispose of all *rubbish* in a clean and sanitary manner by placing such *rubbish* in *approved* containers.

308.2.1 Rubbish storage facilities. The *owner* of every occupied *premises* shall supply *approved* covered containers for *rubbish*, and the *owner* of the *premises* shall be responsible for the removal of *rubbish*.

308.2.2 Refrigerators. Refrigerators and similar equipment not in operation shall not be discarded, abandoned or stored on *premises* without first removing the doors.

308.3 Disposal of garbage. Every *occupant* of a structure shall dispose of garbage in a clean and sanitary manner by placing such garbage in an *approved* garbage disposal facility or *approved* garbage containers.

308.3.1 Garbage facilities. The *owner* of every dwelling shall supply one of the following: an *approved* mechanical food waste grinder in each *dwelling unit*; an *approved* incinerator unit in the structure available to the *occupants* in each *dwelling unit*; or an *approved* leakproof, covered, outside garbage container.

308.3.2 Containers. The *operator* of every establishment producing garbage shall provide, and at all times cause to be utilized, *approved* leakproof containers provided with close-fitting covers for the storage of such materials until removed from the *premises* for disposal.

SECTION 309 PEST ELIMINATION

309.1 Infestation. Structures shall be kept free from insect and rodent *infestation*. Structures in which insects or rodents are found shall be promptly exterminated by *approved* processes that will not be injurious to human health. After pest elimination, proper precautions shall be taken to prevent reinfestation.

309.2 Owner. The *owner* of any structure shall be responsible for pest elimination within the structure prior to renting or leasing the structure.

309.3 Single occupant. The *occupant* of a one-family dwelling or of a single-*tenant* nonresidential structure shall be responsible for pest elimination on the *premises*.

309.4 Multiple occupancy. The *owner* of a structure containing two or more *dwelling units*, a multiple *occupancy*, a

GENERAL REQUIREMENTS

rooming house or a nonresidential structure shall be responsible for pest elimination in the public or shared areas of the structure and *exterior property*. If *infestation* is caused by failure of an *occupant* to prevent such *infestation* in the area occupied, the *occupant* and *owner* shall be responsible for pest elimination.

309.5 Occupant. The *occupant* of any structure shall be responsible for the continued rodent and pest-free condition of the structure.

Exception: Where the *infestations* are caused by defects in the structure, the *owner* shall be responsible for pest elimination.

CHAPTER 4

LIGHT, VENTILATION AND OCCUPANCY LIMITATIONS

SECTION 401 GENERAL

401.1 Scope. The provisions of this chapter shall govern the minimum conditions and standards for light, *ventilation* and space for occupying a structure.

401.2 Responsibility. The *owner* of the structure shall provide and maintain light, *ventilation* and space conditions in compliance with these requirements. A person shall not occupy as *owner-occupant*, or permit another person to occupy, any *premises* that do not comply with the requirements of this chapter.

401.3 Alternative devices. In lieu of the means for natural light and *ventilation* herein prescribed, artificial light or mechanical *ventilation* complying with the *International Building Code* shall be permitted.

SECTION 402 LIGHT

402.1 Habitable spaces. Every *habitable space* shall have not less than one window of *approved* size facing directly to the outdoors or to a court. The minimum total glazed area for every *habitable space* shall be 8 percent of the floor area of such room. Wherever walls or other portions of a structure face a window of any room and such obstructions are located less than 3 feet (914 mm) from the window and extend to a level above that of the ceiling of the room, such window shall not be deemed to face directly to the outdoors nor to a court and shall not be included as contributing to the required minimum total window area for the room.

Exception: Where natural light for rooms or spaces without exterior glazing areas is provided through an adjoining room, the unobstructed opening to the adjoining room shall be not less than 8 percent of the floor area of the interior room or space, but a minimum of 25 square feet (2.33 m²). The exterior glazing area shall be based on the total floor area being served.

402.2 Common halls and stairways. Every common hall and stairway in residential occupancies, other than in one- and two-family dwellings, shall be lighted at all times with not less than a 60-watt standard incandescent light bulb for each 200 square feet (19 m²) of floor area or equivalent illumination, provided that the spacing between lights shall not be greater than 30 feet (9144 mm). In other than residential occupancies, means of egress, including exterior means of egress, stairways shall be illuminated at all times the building space served by the means of egress is occupied with not less than 1 footcandle (11 lux) at floors, landings and treads.

402.3 Other spaces. All other spaces shall be provided with natural or artificial light sufficient to permit the maintenance of sanitary conditions, and the safe *occupancy* of the space and utilization of the appliances, equipment and fixtures.

SECTION 403 VENTILATION

403.1 Habitable spaces. Every *habitable space* shall have not less than one openable window. The total openable area of the window in every room shall be equal to not less than 45 percent of the minimum glazed area required in Section 402.1.

Exception: Where rooms and spaces without openings to the outdoors are ventilated through an adjoining room, the unobstructed opening to the adjoining room shall be not less than 8 percent of the floor area of the interior room or space, but not less than 25 square feet (2.33 m²). The *ventilation* openings to the outdoors shall be based on a total floor area being ventilated.

403.2 Bathrooms and toilet rooms. Every *bathroom* and *toilet room* shall comply with the *ventilation* requirements for *habitable spaces* as required by Section 403.1, except that a window shall not be required in such spaces equipped with a mechanical *ventilation* system. Air exhausted by a mechanical *ventilation* system from a *bathroom* or *toilet room* shall discharge to the outdoors and shall not be recirculated.

403.3 Cooking facilities. Unless *approved* through the certificate of *occupancy*, cooking shall not be permitted in any *rooming unit* or dormitory unit, and a cooking facility or appliance shall not be permitted to be present in the *rooming unit* or dormitory unit.

Exceptions:

1. Where specifically *approved* in writing by the *code official*.
2. Devices such as coffee pots and microwave ovens shall not be considered cooking appliances.

403.4 Process ventilation. Where injurious, toxic, irritating or noxious fumes, gases, dusts or mists are generated, a local exhaust *ventilation* system shall be provided to remove the contaminating agent at the source. Air shall be exhausted to the exterior and not be recirculated to any space.

403.5 Clothes dryer exhaust. Clothes dryer exhaust systems shall be independent of all other systems and shall be exhausted outside the structure in accordance with the manufacturer's instructions.

Exception: Listed and *labeled* condensing (ductless) clothes dryers.

SECTION 404 OCCUPANCY LIMITATIONS

404.1 Privacy. *Dwelling units*, hotel units, *housekeeping units*, *rooming units* and dormitory units shall be arranged to provide privacy and be separate from other adjoining spaces.

LIGHT, VENTILATION AND OCCUPANCY LIMITATIONS

404.2 Minimum room widths. A habitable room, other than a kitchen, shall be not less than 7 feet (2134 mm) in any plan dimension. Kitchens shall have a minimum clear passageway of 3 feet (914 mm) between counterfronts and appliances or counterfronts and walls.

404.3 Minimum ceiling heights. *Habitable spaces*, hallways, corridors, laundry areas, *bathrooms*, *toilet rooms* and habitable *basement* areas shall have a minimum clear ceiling height of 7 feet (2134 mm).

Exceptions:

1. In one- and two-family dwellings, beams or girders spaced not less than 4 feet (1219 mm) on center and projecting a maximum of 6 inches (152 mm) below the required ceiling height.
2. *Basement* rooms in one- and two-family dwellings occupied exclusively for laundry, study or recreation purposes, having a minimum ceiling height of 6 feet 8 inches (2033 mm) with a minimum clear height of 6 feet 4 inches (1932 mm) under beams, girders, ducts and similar obstructions.
3. Rooms occupied exclusively for sleeping, study or similar purposes and having a sloped ceiling over all or part of the room, with a minimum clear ceiling height of 7 feet (2134 mm) over not less than one-third of the required minimum floor area. In calculating the floor area of such rooms, only those portions of the floor area with a minimum clear ceiling height of 5 feet (1524 mm) shall be included.

404.4 Bedroom and living room requirements. Every *bedroom* and living room shall comply with the requirements of Sections 404.4.1 through 404.4.5.

404.4.1 Room area. Every living room shall contain not less than 120 square feet (11.2 m²) and every bedroom shall contain not less than 70 square feet (6.5 m²) and every bedroom occupied by more than one person shall contain not less than 50 square feet (4.6 m²) of floor area for each occupant thereof.

404.4.2 Access from bedrooms. *Bedrooms* shall not constitute the only means of access to other *bedrooms* or *habitable spaces* and shall not serve as the only means of egress from other *habitable spaces*.

Exception: Units that contain fewer than two *bedrooms*.

404.4.3 Water closet accessibility. Every *bedroom* shall have access to not less than one water closet and one lavatory without passing through another *bedroom*. Every *bedroom* in a *dwelling unit* shall have access to not less than one water closet and lavatory located in the same story as the *bedroom* or an adjacent story.

404.4.4 Prohibited occupancy. Kitchens and nonhabitable spaces shall not be used for sleeping purposes.

404.4.5 Other requirements. *Bedrooms* shall comply with the applicable provisions of this code including, but not limited to, the light, *ventilation*, room area, ceiling height and room width requirements of this chapter; the plumbing facilities and water-heating facilities require-

ments of Chapter 5; the heating facilities and electrical receptacle requirements of Chapter 6; and the smoke detector and emergency escape requirements of Chapter 7.

404.5 Overcrowding. Dwelling units shall not be occupied by more occupants than permitted by the minimum area requirements of Table 404.5.

**TABLE 404.5
MINIMUM AREA REQUIREMENTS**

SPACE	MINIMUM AREA IN SQUARE FEET		
	1-2 occupants	3-5 occupants	6 or more occupants
Living room ^{a, b}	120	120	150
Dining room ^{a, b}	No requirement	80	100
Bedrooms	Shall comply with Section 404.4.1		

For SI: 1 square foot = 0.0929 m².

a. See Section 404.5.2 for combined living room/dining room spaces.

b. See Section 404.5.1 for limitations on determining the minimum occupancy area for sleeping purposes.

404.5.1 Sleeping area. The minimum occupancy area required by Table 404.5 shall not be included as a sleeping area in determining the minimum occupancy area for sleeping purposes. Sleeping areas shall comply with Section 404.4.

404.5.2 Combined spaces. Combined living room and dining room spaces shall comply with the requirements of Table 404.5 if the total area is equal to that required for separate rooms and if the space is located so as to function as a combination living room/dining room.

404.6 Efficiency unit. Nothing in this section shall prohibit an efficiency living unit from meeting the following requirements:

1. A unit occupied by not more than one occupant shall have a minimum clear floor area of 120 square feet (11.2 m²). A unit occupied by not more than two *occupants* shall have a minimum clear floor area of 220 square feet (20.4 m²). A unit occupied by three *occupants* shall have a minimum clear floor area of 320 square feet (29.7 m²). These required areas shall be exclusive of the areas required by Items 2 and 3.
2. The unit shall be provided with a kitchen sink, cooking appliance and refrigeration facilities, each having a minimum clear working space of 30 inches (762 mm) in front. Light and *ventilation* conforming to this code shall be provided.
3. The unit shall be provided with a separate *bathroom* containing a water closet, lavatory and bathtub or shower.
4. The maximum number of *occupants* shall be three.

404.7 Food preparation. All spaces to be occupied for food preparation purposes shall contain suitable space and equipment to store, prepare and serve foods in a sanitary manner. There shall be adequate facilities and services for the sanitary disposal of food wastes and refuse, including facilities for temporary storage.

CHAPTER 5

PLUMBING FACILITIES AND FIXTURE REQUIREMENTS

SECTION 501 GENERAL

501.1 Scope. The provisions of this chapter shall govern the minimum plumbing systems, facilities and plumbing fixtures to be provided.

501.2 Responsibility. The *owner* of the structure shall provide and maintain such plumbing facilities and plumbing fixtures in compliance with these requirements. A person shall not occupy as *owner-occupant* or permit another person to occupy any structure or *premises* that does not comply with the requirements of this chapter.

SECTION 502 REQUIRED FACILITIES

[P] 502.1 Dwelling units. Every *dwelling unit* shall contain its own bathtub or shower, lavatory, water closet and kitchen sink that shall be maintained in a sanitary, safe working condition. The lavatory shall be placed in the same room as the water closet or located in close proximity to the door leading directly into the room in which such water closet is located. A kitchen sink shall not be used as a substitute for the required lavatory.

[P] 502.2 Rooming houses. Not less than one water closet, lavatory and bathtub or shower shall be supplied for each four *rooming units*.

[P] 502.3 Hotels. Where private water closets, lavatories and baths are not provided, one water closet, one lavatory and one bathtub or shower having access from a public hallway shall be provided for each 10 *occupants*.

[P] 502.4 Employees' facilities. Not less than one water closet, one lavatory and one drinking facility shall be available to employees.

[P] 502.4.1 Drinking facilities. Drinking facilities shall be a drinking fountain, water cooler, bottled water cooler or disposable cups next to a sink or water dispenser. Drinking facilities shall not be located in *toilet rooms* or *bathrooms*.

[P] 502.5 Public toilet facilities. Public toilet facilities shall be maintained in a safe, sanitary and working condition in accordance with the *International Plumbing Code*. Except for periodic maintenance or cleaning, public access and use shall be provided to the toilet facilities at all times during *occupancy* of the *premises*.

SECTION 503 TOILET ROOMS

[P] 503.1 Privacy. *Toilet rooms* and *bathrooms* shall provide privacy and shall not constitute the only passageway to a hall or other space, or to the exterior. A door and interior locking

device shall be provided for all common or shared *bathrooms* and *toilet rooms* in a multiple dwelling.

[P] 503.2 Location. *Toilet rooms* and *bathrooms* serving hotel units, *rooming units* or dormitory units or *housekeeping units*, shall have access by traversing not more than one flight of stairs and shall have access from a common hall or passageway.

[P] 503.3 Location of employee toilet facilities. Toilet facilities shall have access from within the employees' working area. The required toilet facilities shall be located not more than one story above or below the employees' working area and the path of travel to such facilities shall not exceed a distance of 500 feet (152 m). Employee facilities shall either be separate facilities or combined employee and public facilities.

Exception: Facilities that are required for employees in storage structures or kiosks, which are located in adjacent structures under the same ownership, lease or control, shall not exceed a travel distance of 500 feet (152 m) from the employees' regular working area to the facilities.

[P] 503.4 Floor surface. In other than *dwelling units*, every *toilet room* floor shall be maintained to be a smooth, hard, nonabsorbent surface to permit such floor to be easily kept in a clean and sanitary condition.

SECTION 504 PLUMBING SYSTEMS AND FIXTURES

[P] 504.1 General. Plumbing fixtures shall be properly installed and maintained in working order, and shall be kept free from obstructions, leaks and defects and be capable of performing the function for which such plumbing fixtures are designed. Plumbing fixtures shall be maintained in a safe, sanitary and functional condition.

[P] 504.2 Fixture clearances. Plumbing fixtures shall have adequate clearances for usage and cleaning.

[P] 504.3 Plumbing system hazards. Where it is found that a plumbing system in a structure constitutes a hazard to the *occupants* or the structure by reason of inadequate service, inadequate venting, cross connection, backsiphonage, improper installation, *deterioration* or damage or for similar reasons, the *code official* shall require the defects to be corrected to eliminate the hazard.

SECTION 505 WATER SYSTEM

505.1 General. Every sink, lavatory, bathtub or shower, drinking fountain, water closet or other plumbing fixture shall be properly connected to either a public water system or to an *approved* private water system. Kitchen sinks, lavatories, laundry facilities, bathtubs and showers shall be supplied

PLUMBING FACILITIES AND FIXTURE REQUIREMENTS

with hot or tempered and cold running water in accordance with the *International Plumbing Code*.

[P] 505.2 Contamination. The water supply shall be maintained free from contamination, and all water inlets for plumbing fixtures shall be located above the flood-level rim of the fixture. Shampoo basin faucets, janitor sink faucets and other hose bibs or faucets to which hoses are attached and left in place, shall be protected by an approved atmospheric-type vacuum breaker or an approved permanently attached hose connection vacuum breaker.

505.3 Supply. The water supply system shall be installed and maintained to provide a supply of water to plumbing fixtures, devices and appurtenances in sufficient volume and at pressures adequate to enable the fixtures to function properly, safely, and free from defects and leaks.

505.4 Water heating facilities. Water heating facilities shall be properly installed, maintained and capable of providing an adequate amount of water to be drawn at every required sink, lavatory, bathtub, shower and laundry facility at a minimum temperature of 110°F (43°C). A gas-burning water heater shall not be located in any *bathroom, toilet room, bedroom* or other occupied room normally kept closed, unless adequate combustion air is provided. An *approved* combination temperature and pressure-relief valve and relief valve discharge pipe shall be properly installed and maintained on water heaters.

SECTION 506 SANITARY DRAINAGE SYSTEM

[P] 506.1 General. Plumbing fixtures shall be properly connected to either a public sewer system or to an *approved* private sewage disposal system.

[P] 506.2 Maintenance. Every plumbing stack, vent, waste and sewer line shall function properly and be kept free from obstructions, leaks and defects.

[P] 506.3 Grease interceptors. Grease interceptors and automatic grease removal devices shall be maintained in accordance with this code and the manufacturer's installation instructions. Grease interceptors and automatic grease removal devices shall be regularly serviced and cleaned to prevent the discharge of oil, grease, and other substances harmful or hazardous to the building drainage system, the public sewer, the private sewage disposal system or the sewage treatment plant or processes. Records of maintenance, cleaning and repairs shall be available for inspection by the code official.

SECTION 507 STORM DRAINAGE

[P] 507.1 General. Drainage of roofs and paved areas, *yards* and courts, and other open areas on the *premises* shall not be discharged in a manner that creates a public nuisance.

CHAPTER 6

MECHANICAL AND ELECTRICAL REQUIREMENTS

SECTION 601 GENERAL

601.1 Scope. The provisions of this chapter shall govern the minimum mechanical and electrical facilities and equipment to be provided.

601.2 Responsibility. The *owner* of the structure shall provide and maintain mechanical and electrical facilities and equipment in compliance with these requirements. A person shall not occupy as *owner-occupant* or permit another person to occupy any *premises* that does not comply with the requirements of this chapter.

SECTION 602 HEATING FACILITIES

602.1 Facilities required. Heating facilities shall be provided in structures as required by this section.

602.2 Residential occupancies. Dwellings shall be provided with heating facilities capable of maintaining a room temperature of 68°F (20°C) in all habitable rooms, *bathrooms* and *toilet rooms* based on the winter outdoor design temperature for the locality indicated in Appendix D of the *International Plumbing Code*. Cooking appliances shall not be used, nor shall portable unvented fuel-burning space heaters be used, as a means to provide required heating.

Exception: In areas where the average monthly temperature is above 30°F (-1°C), a minimum temperature of 65°F (18°C) shall be maintained.

602.3 Heat supply. Every *owner* and *operator* of any building who rents, leases or lets one or more *dwelling units* or *sleeping units* on terms, either expressed or implied, to furnish heat to the *occupants* thereof shall supply heat during the period from [DATE] to [DATE] to maintain a minimum temperature of 68°F (20°C) in all habitable rooms, *bathrooms* and *toilet rooms*.

Exceptions:

1. When the outdoor temperature is below the winter outdoor design temperature for the locality, maintenance of the minimum room temperature shall not be required provided that the heating system is operating at its full design capacity. The winter outdoor design temperature for the locality shall be as indicated in Appendix D of the *International Plumbing Code*.
2. In areas where the average monthly temperature is above 30°F (-1°C), a minimum temperature of 65°F (18°C) shall be maintained.

602.4 Occupiable work spaces. Indoor occupiable work spaces shall be supplied with heat during the period from [DATE] to [DATE] to maintain a minimum temperature of 65°F (18°C) during the period the spaces are occupied.

Exceptions:

1. Processing, storage and operation areas that require cooling or special temperature conditions.
2. Areas in which persons are primarily engaged in vigorous physical activities.

602.5 Room temperature measurement. The required room temperatures shall be measured 3 feet (914 mm) above the floor near the center of the room and 2 feet (610 mm) inward from the center of each exterior wall.

SECTION 603 MECHANICAL EQUIPMENT

603.1 Mechanical appliances. Mechanical appliances, fireplaces, solid fuel-burning appliances, cooking appliances and water heating appliances shall be properly installed and maintained in a safe working condition, and shall be capable of performing the intended function.

603.2 Removal of combustion products. Fuel-burning equipment and appliances shall be connected to an *approved* chimney or vent.

Exception: Fuel-burning equipment and appliances that are *labeled* for unvented operation.

603.3 Clearances. Required clearances to combustible materials shall be maintained.

603.4 Safety controls. Safety controls for fuel-burning equipment shall be maintained in effective operation.

603.5 Combustion air. A supply of air for complete combustion of the fuel and for *ventilation* of the space containing the fuel-burning equipment shall be provided for the fuel-burning equipment.

603.6 Energy conservation devices. Devices intended to reduce fuel consumption by attachment to a fuel-burning appliance, to the fuel supply line thereto, or to the vent outlet or vent piping therefrom, shall not be installed unless *labeled* for such purpose and the installation is specifically *approved*.

SECTION 604 ELECTRICAL FACILITIES

604.1 Facilities required. Every occupied building shall be provided with an electrical system in compliance with the requirements of this section and Section 605.

MECHANICAL AND ELECTRICAL REQUIREMENTS

604.2 Service. The size and usage of appliances and equipment shall serve as a basis for determining the need for additional facilities in accordance with NFPA 70. *Dwelling units* shall be served by a three-wire, 120/240 volt, single-phase electrical service having a minimum rating of 60 amperes.

604.3 Electrical system hazards. Where it is found that the electrical system in a structure constitutes a hazard to the *occupants* or the structure by reason of inadequate service, improper fusing, insufficient receptacle and lighting outlets, improper wiring or installation, *deterioration* or damage, or for similar reasons, the *code official* shall require the defects to be corrected to eliminate the hazard.

604.3.1 Abatement of electrical hazards associated with water exposure. The provisions of this section shall govern the repair and replacement of electrical systems and equipment that have been exposed to water.

604.3.1.1 Electrical equipment. Electrical distribution equipment, motor circuits, power equipment, transformers, wire, cable, flexible cords, wiring devices, ground fault circuit interrupters, surge protectors, molded case circuit breakers, low-voltage fuses, luminaires, ballasts, motors and electronic control, signaling and communication equipment that have been exposed to water shall be replaced in accordance with the provisions of the *International Building Code*.

Exception: The following equipment shall be allowed to be repaired where an inspection report from the equipment manufacturer or *approved* manufacturer's representative indicates that the equipment has not sustained damage that requires replacement:

1. Enclosed switches, rated a maximum of 600 volts or less;
2. Busway, rated a maximum of 600 volts;
3. Panelboards, rated a maximum of 600 volts;
4. Switchboards, rated a maximum of 600 volts;
5. Fire pump controllers, rated a maximum of 600 volts;
6. Manual and magnetic motor controllers;
7. Motor control centers;
8. Alternating current high-voltage circuit breakers;
9. Low-voltage power circuit breakers;
10. Protective relays, meters and current transformers;
11. Low- and medium-voltage switchgear;
12. Liquid-filled transformers;
13. Cast-resin transformers;
14. Wire or cable that is suitable for wet locations and whose ends have not been exposed to water;

15. Wire or cable, not containing fillers, that is suitable for wet locations and whose ends have not been exposed to water;
16. Luminaires that are listed as submersible;
17. Motors;
18. Electronic control, signaling and communication equipment.

604.3.2 Abatement of electrical hazards associated with fire exposure. The provisions of this section shall govern the repair and replacement of electrical systems and equipment that have been exposed to fire.

604.3.2.1 Electrical equipment. Electrical switches, receptacles and fixtures, including furnace, water heating, security system and power distribution circuits, that have been exposed to fire, shall be replaced in accordance with the provisions of the *International Building Code*.

Exception: Electrical switches, receptacles and fixtures that shall be allowed to be repaired where an inspection report from the equipment manufacturer or *approved* manufacturer's representative indicates that the equipment has not sustained damage that requires replacement.

SECTION 605 ELECTRICAL EQUIPMENT

605.1 Installation. Electrical equipment, wiring and appliances shall be properly installed and maintained in a safe and *approved* manner.

605.2 Receptacles. Every *habitable space* in a dwelling shall contain not less than two separate and remote receptacle outlets. Every laundry area shall contain not less than one grounding-type receptacle or a receptacle with a ground fault circuit interrupter. Every *bathroom* shall contain not less than one receptacle. Any new *bathroom* receptacle outlet shall have ground fault circuit interrupter protection. All receptacle outlets shall have the appropriate faceplate cover for the location.

605.3 Luminaires. Every public hall, interior stairway, *toilet room*, kitchen, *bathroom*, laundry room, boiler room and furnace room shall contain not less than one electric luminaire. Pool and spa luminaires over 15 V shall have ground fault circuit interrupter protection.

605.4 Wiring. Flexible cords shall not be used for permanent wiring, or for running through doors, windows, or cabinets, or concealed within walls, floors, or ceilings.

SECTION 606 ELEVATORS, ESCALATORS AND DUMBWAITERS

606.1 General. Elevators, dumbwaiters and escalators shall be maintained in compliance with ASME A17.1. The most current certificate of inspection shall be on display at all times within the elevator or attached to the escalator or dumb-

waiter, be available for public inspection in the office of the building *operator* or be posted in a publicly conspicuous location *approved* by the *code official*. The inspection and tests shall be performed at not less than the periodic intervals listed in ASME A17.1, Appendix N, except where otherwise specified by the authority having jurisdiction.

606.2 Elevators. In buildings equipped with passenger elevators, not less than one elevator shall be maintained in operation at all times when the building is occupied.

Exception: Buildings equipped with only one elevator shall be permitted to have the elevator temporarily out of service for testing or servicing.

SECTION 607 DUCT SYSTEMS

607.1 General. Duct systems shall be maintained free of obstructions and shall be capable of performing the required function.

CHAPTER 7

FIRE SAFETY REQUIREMENTS

SECTION 701 GENERAL

701.1 Scope. The provisions of this chapter shall govern the minimum conditions and standards for fire safety relating to structures and exterior *premises*, including fire safety facilities and equipment to be provided.

701.2 Responsibility. The *owner* of the *premises* shall provide and maintain such fire safety facilities and equipment in compliance with these requirements. A person shall not occupy as *owner-occupant* or permit another person to occupy any *premises* that do not comply with the requirements of this chapter.

SECTION 702 MEANS OF EGRESS

[F] 702.1 General. A safe, continuous and unobstructed path of travel shall be provided from any point in a building or structure to the *public way*. Means of egress shall comply with the *International Fire Code*.

[F] 702.2 Aisles. The required width of aisles in accordance with the *International Fire Code* shall be unobstructed.

[F] 702.3 Locked doors. Means of egress doors shall be readily openable from the side from which egress is to be made without the need for keys, special knowledge or effort, except where the door hardware conforms to that permitted by the *International Building Code*.

[F] 702.4 Emergency escape openings. Required emergency escape openings shall be maintained in accordance with the code in effect at the time of construction, and the following. Required emergency escape and rescue openings shall be operational from the inside of the room without the use of keys or tools. Bars, grilles, grates or similar devices are permitted to be placed over emergency escape and rescue openings provided the minimum net clear opening size complies with the code that was in effect at the time of construction and such devices shall be releasable or removable from the inside without the use of a key, tool or force greater than that which is required for normal operation of the escape and rescue opening.

SECTION 703 FIRE-RESISTANCE RATINGS

[F] 703.1 Fire-resistance-rated assemblies. The required fire-resistance rating of fire-resistance-rated walls, fire stops, shaft enclosures, partitions and floors shall be maintained.

[F] 703.2 Opening protectives. Required opening protectives shall be maintained in an operative condition. Fire and smokestop doors shall be maintained in operable condition. Fire doors and smoke barrier doors shall not be blocked or obstructed or otherwise made inoperable.

SECTION 704 FIRE PROTECTION SYSTEMS

[F] 704.1 General. Systems, devices and equipment to detect a fire, actuate an alarm, or suppress or control a fire or any combination thereof shall be maintained in an operable condition at all times in accordance with the *International Fire Code*.

[F] 704.1.1 Automatic sprinkler systems. Inspection, testing and maintenance of automatic sprinkler systems shall be in accordance with NFPA 25.

[F] 704.1.2 Fire department connection. Where the fire department connection is not visible to approaching fire apparatus, the fire department connection shall be indicated by an *approved* sign mounted on the street front or on the side of the building. Such sign shall have the letters "FDC" not less than 6 inches (152 mm) high and words in letters not less than 2 inches (51 mm) high or an arrow to indicate the location. Such signs shall be subject to the approval of the fire code official.

[F] 704.2 Single- and multiple-station smoke alarms. Single- and multiple-station smoke alarms shall be installed in existing Group I-1 and R occupancies in accordance with Sections 704.2.1 through 704.2.3.

[F] 704.2.1 Where required. Existing Group I-1 and R occupancies shall be provided with single-station smoke alarms in accordance with Sections 704.2.1.1 through 704.2.1.4. Interconnection and power sources shall be in accordance with Sections 704.2.2 and 704.2.3.

Exceptions:

1. Where the code that was in effect at the time of construction required smoke alarms and smoke alarms complying with those requirements are already provided.
2. Where smoke alarms have been installed in occupancies and dwellings that were not required to have them at the time of construction, additional smoke alarms shall not be required provided that the existing smoke alarms comply with requirements that were in effect at the time of installation.
3. Where smoke detectors connected to a fire alarm system have been installed as a substitute for smoke alarms.

[F] 704.2.1.1 Group R-1. Single- or multiple-station smoke alarms shall be installed in all of the following locations in Group R-1:

1. In sleeping areas.
2. In every room in the path of the *means of egress* from the sleeping area to the door leading from the *sleeping unit*.

3. In each story within the *sleeping unit*, including basements. For *sleeping units* with split levels and without an intervening door between the adjacent levels, a smoke alarm installed on the upper level shall suffice for the adjacent lower level provided that the lower level is less than one full story below the upper level.

[F] 704.2.1.2 Groups R-2, R-3, R-4 and I-1. Single- or multiple-station smoke alarms shall be installed and maintained in Groups R-2, R-3, R-4 and I-1 regardless of *occupant load* at all of the following locations:

1. On the ceiling or wall outside of each separate sleeping area in the immediate vicinity of bedrooms.
2. In each room used for sleeping purposes.
3. In each story within a *dwelling unit*, including *basements* but not including crawl spaces and uninhabitable attics. In *dwellings* or *dwelling units* with split levels and without an intervening door between the adjacent levels, a smoke alarm installed on the upper level shall suffice for the adjacent lower level provided that the lower level is less than one full story below the upper level.

[F] 704.2.1.3 Installation near cooking appliances. Smoke alarms shall not be installed in the following locations unless this would prevent placement of a smoke alarm in a location required by Section 704.2.1.1 or 704.2.1.2.

1. Ionization smoke alarms shall not be installed less than 20 feet (6096 mm) horizontally from a permanently installed cooking appliance.
2. Ionization smoke alarms with an alarm-silencing switch shall not be installed less than 10 feet (3048 mm) horizontally from a permanently installed cooking appliance.
3. Photoelectric smoke alarms shall not be installed less than 6 feet (1829 mm) horizontally from a permanently installed cooking appliance.

[F] 704.2.1.4 Installation near bathrooms. Smoke alarms shall be installed not less than 3 feet (914 mm) horizontally from the door or opening of a bathroom that contains a bathtub or shower unless this would prevent placement of a smoke alarm required by Section 704.2.1.1 or 704.2.1.2.

[F] 704.2.2 Interconnection. Where more than one smoke alarm is required to be installed within an individual *dwelling* or *sleeping unit*, the smoke alarms shall be interconnected in such a manner that the activation of one alarm will activate all of the alarms in the individual unit. Physical interconnection of smoke alarms shall not be required where listed wireless alarms are installed and all alarms sound upon activation of one alarm. The alarm shall be clearly audible in all bedrooms over background noise levels with all intervening doors closed.

Exceptions:

1. Interconnection is not required in buildings that are not undergoing *alterations*, repairs or construction of any kind.

2. Smoke alarms in existing areas are not required to be interconnected where *alterations* or repairs do not result in the removal of interior wall or ceiling finishes exposing the structure, unless there is an attic, crawl space or basement available that could provide access for interconnection without the removal of interior finishes.

[F] 704.2.3 Power source. Single-station smoke alarms shall receive their primary power from the building wiring provided that such wiring is served from a commercial source and shall be equipped with a battery backup. Smoke alarms with integral strobes that are not equipped with battery backup shall be connected to an emergency electrical system. Smoke alarms shall emit a signal when the batteries are low. Wiring shall be permanent and without a disconnecting switch other than as required for over-current protection.

Exceptions:

1. Smoke alarms are permitted to be solely battery operated in existing buildings where no construction is taking place.
2. Smoke alarms are permitted to be solely battery operated in buildings that are not served from a commercial power source.
3. Smoke alarms are permitted to be solely battery operated in existing areas of buildings undergoing *alterations* or repairs that do not result in the removal of interior walls or ceiling finishes exposing the structure, unless there is an attic, crawl space or *basement* available that could provide access for building wiring without the removal of interior finishes.

[F] 704.2.4 Smoke detection system. Smoke detectors listed in accordance with UL 268 and provided as part of the building's fire alarm system shall be an acceptable alternative to single- and multiple-station smoke alarms and shall comply with the following:

1. The fire alarm system shall comply with all applicable requirements in Section 907 of the *International Fire Code*.
2. Activation of a smoke detector in a dwelling or sleeping unit shall initiate alarm notification in the *dwelling* or *sleeping unit* in accordance with Section 907.5.2 of the *International Fire Code*.
3. Activation of a smoke detector in a *dwelling* or *sleeping unit* shall not activate alarm notification appliances outside of the *dwelling* or *sleeping unit*, provided that a supervisory signal is generated and monitored in accordance with Section 907.6.5 of the *International Fire Code*.

CHAPTER 8

REFERENCED STANDARDS

This chapter lists the standards that are referenced in various sections of this document. The standards are listed herein by the promulgating agency of the standard, the standard identification, the effective date and title and the section or sections of this document that reference the standard. The application of the referenced standards shall be as specified in Section 102.7.

ASME American Society of Mechanical Engineers
 Three Park Avenue
 New York, NY 10016-5990

Standard reference number	Title	Referenced in code section number
ASME A17.1/CSA B44—2013	Safety Code for Elevators and Escalators606.1

ASTM ASTM International
 100 Barr Harbor Drive
 West Conshohocken, PA 19428-2959

Standard reference number	Title	Referenced in code section number
F 1346—91 (2010)	Performance Specifications for Safety Covers and Labeling Requirements for All Covers for Swimming Pools, Spas and Hot Tubs303.2

ICC International Code Council
 500 New Jersey Avenue, NW
 6th Floor
 Washington, DC 20001

Standard reference number	Title	Referenced in code section number
IBC—15	International Building Code®	102.3, 201.3, 401.3, 702.3
IEBC—15	International Existing Building Code®	305.1.1, 306.1.1
IFC—15	International Fire Code®	201.3, 604.3.1.1, 604.3.2.1, 702.1, 702.2, 704.1, 704.2
IFGC—15	International Fuel Gas Code®102.3
IMC—15	International Mechanical Code®	102.3, 201.3
IPC—15	International Plumbing Code®	201.3, 505.1, 602.2, 602.3
IRC—15	International Residential Code®201.3
IZC—15	International Zoning Code®	102.3, 201.3

NFPA National Fire Protection Association
 1 Batterymarch Park
 Quincy, MA 02269

Standard reference number	Title	Referenced in code section number
25—14	Standard for the Inspection, Testing and Maintenance of Water-Based Fire Protection Systems	704.1.1
70—14	National Electrical Code102.4, 201.3, 604.2

APPENDIX A

BOARDING STANDARD

The provisions contained in this appendix are not mandatory unless specifically referenced in the adopting ordinance.

A101 GENERAL

A101.1 General. Windows and doors shall be boarded in an *approved* manner to prevent entry by unauthorized persons and shall be painted to correspond to the color of the existing structure.

A102 MATERIALS

A102.1 Boarding sheet material. Boarding sheet material shall be minimum $\frac{1}{2}$ -inch-thick (12.7 mm) wood structural panels complying with the *International Building Code*.

A102.2 Boarding framing material. Boarding framing material shall be minimum nominal 2-inch by 4-inch (51 mm by 102 mm) solid sawn lumber complying with the *International Building Code*.

A102.3 Boarding fasteners. Boarding fasteners shall be minimum $\frac{3}{8}$ -inch-diameter (9.5 mm) carriage bolts of such a length as required to penetrate the assembly and as required to adequately attach the washers and nuts. Washers and nuts shall comply with the *International Building Code*.

A103 INSTALLATION

A103.1 Boarding installation. The boarding installation shall be in accordance with Figures A103.1(1) and A103.1(2) and Sections A103.2 through A103.5.

A103.2 Boarding sheet material. The boarding sheet material shall be cut to fit the door or window opening neatly or shall be cut to provide an equal overlap at the perimeter of the door or window.

A103.3 Windows. The window shall be opened to allow the carriage bolt to pass through or the window sash shall be removed and stored. The 2-inch by 4-inch (51 mm by 102 mm) strong back framing material shall be cut minimum 2 inches (51 mm) wider than the window opening and shall be placed on the inside of the window opening 6 inches (152 mm) minimum above the bottom and below the top of the window opening. The framing and boarding shall be pre-drilled. The assembly shall be aligned and the bolts, washers and nuts shall be installed and secured.

A103.4 Door walls. The door opening shall be framed with minimum 2-inch by 4-inch (51 mm by 102 mm) framing material secured at the entire perimeter and vertical members at a maximum of 24 inches (610 mm) on center. Blocking shall also be secured at a maximum of 48 inches (1219 mm) on center vertically. Boarding sheet material shall be secured

with screws and nails alternating every 6 inches (152 mm) on center.

A103.5 Doors. Doors shall be secured by the same method as for windows or door openings. One door to the structure shall be available for authorized entry and shall be secured and locked in an *approved* manner.

A104 REFERENCED STANDARD

IBC—12 International Building Code A102.1,
A102.2, A102.3

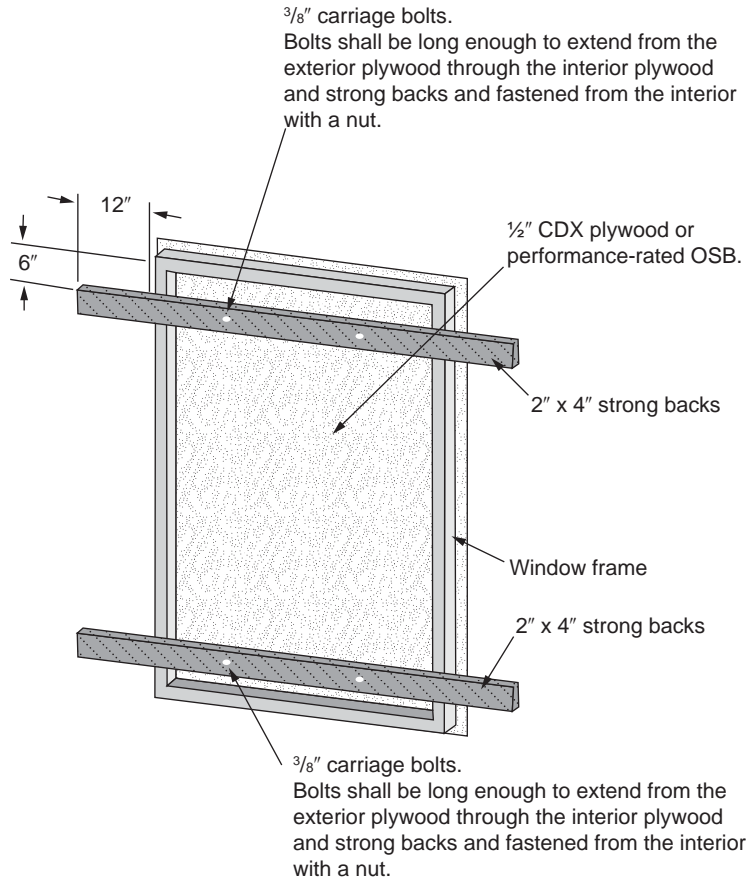

FIGURE A103.1(1)
BOARDING OF DOOR OR WINDOW

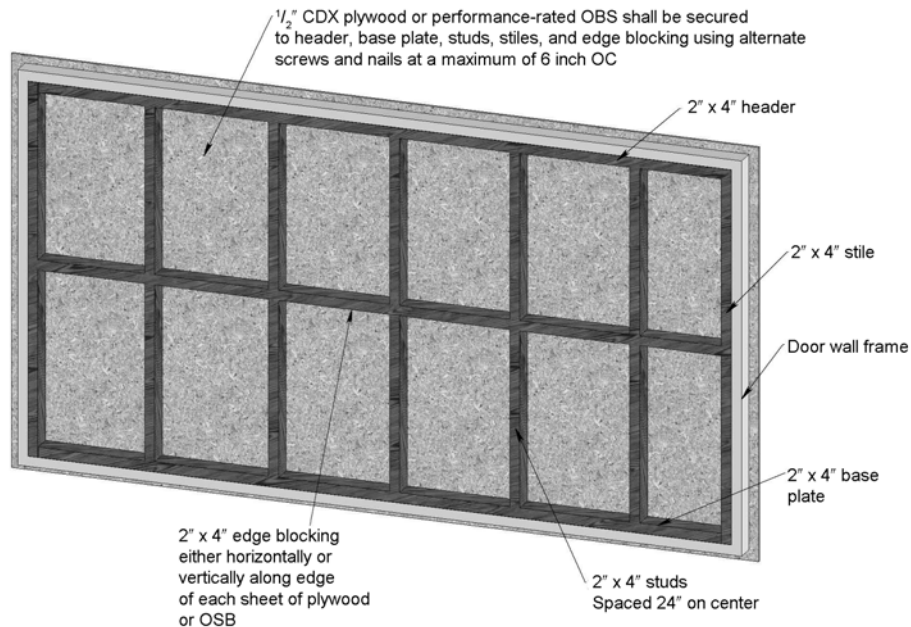

FIGURE A103.1(2)
BOARDING OF DOOR WALL

INDEX

A

ACCESS

- Emergency egress 702
- From bedrooms 404.4.2
- Plumbing fixtures, access for cleaning 504.2
- To public way 702.1
- Toilet room as passageway 503.1
- Water closet 404.4.3

ADJACENT

- Privacy (hotel units, rooming units). 404.1

ADMINISTRATION

- Scope 101.2

AGENT (See also OPERATOR, OWNER)

- Definition. 202

AIR

- Combustion air 603.5

AISLES

- Minimum width 702.2

ALTERATION

- Applicability of other codes 102.3
- Inspection 104.2
- Prosecution. 106.3
- Unlawful acts 106.1

ANCHOR

- Anchored, definition 202
- Architectural trim. 304.8
- Signs, marquees and awnings 304.9
- Unsafe conditions. 304.1.1

APPEAL

- Application 111.1
- Board decision 111.6
- Board of appeals 111.2
- Court review 111.7
- Disqualification 111.2.3
- Financial interest 111.2.3
- Hearing, emergency orders 109.6
- Membership 111.2
- Notice of appeal 111.1
- Postponed hearing 111.5
- Records 104.6
- Right to appeal 111.1
- Vote 111.6

APPLIANCE

- Cooking 403.3, 602.2
- Mechanical 603.1

APPLICABILITY

- Application of references 102.9

- General. 102.1
- Other laws. 102.10
- Referenced codes and standards. 102.7

APPROVAL

- Alternatives 105.2
- Authority 104.1, 105.2
- Modifications. 105.1
- Research reports 105.6
- Used material and equipment. 105.4

APPROVED

- Alternative materials, methods and equipment 105.2
- Definition. 202
- Energy conservation devices 603.6
- Garbage storage facilities. 308.3.1
- Modifications. 105.1
- Used materials and equipment. 105.4

ARTIFICIAL

- Lighting of habitable rooms. 401.3
- Lighting of other spaces 402.3

AUTOMOBILE

- Motor vehicles. 302.8

AWNING

- Signs, marquees and awnings 304.9

B

BALCONY

- Handrails and guardrails. 304.12

BASEMENT

- Definition. 202
- Hatchways 304.16
- Windows 304.17

BATHROOM

- Common bathrooms 502.3, 503.1
- Hotels 502.3
- Lighting 605.3
- Locks. 503.1
- Outlets required 605.2
- Privacy 503.1
- Ventilation 403.2

BATHTUB

- Dwelling units 502.1
- Rooming houses. 502.2
- Sewage system. 506.1
- Water-heating facilities 505.4
- Water system 505.1

BOARDING

Boarding standard Appendix A

BOILER

Unsafe equipment 108.1.2

C

CAPACITY

Heating facilities 602.2, 602.3, 602.4

CAR (See AUTOMOBILE)

CEILING

Basement rooms 404.3
 Fire-resistance ratings 703.1
 Interior surfaces 305.3
 Minimum height 404.3
 Sleeping rooms 404.3

CHANGE, MODIFY

Application of other codes 102.3

CHIMNEY

Exterior structure 304.11
 Flue 603.2, 603.3

CLEANING

Access for cleaning 504.2
 Disposal of garbage 308.3
 Disposal of rubbish 308.2
 Interior and exterior sanitation 308.1
 Interior surfaces 305.3
 Plumbing facilities, maintained 504.1
 Required plumbing facilities 502
 Responsibility of persons 305.1
 Trash containers 308.3.2
 Vacant structures and land 301.3

CLEARANCE

Heating facilities 603.3
 Plumbing fixtures 504.2

CLOSING

Streets 109.3
 Vacant structures 108.2

CLOTHES DRYER

Exhaust 403.5

CODE OFFICIAL

Condemnation 108.1
 Demolition 110
 Duties 104
 Emergency order 109
 Enforcement authority 104.1
 Failure to comply with demolition order 110.3
 Identification 104.3
 Inspections 104.2
 Liability, relief of personal 103.4
 Membership of board of appeals 111.2
 Notice of violation 104.5, 107

Notices and orders 107
 Official records 104.6
 Personal liability 103.4
 Placarding 108.4
 Prosecution 106.3
 Removal of placard 108.4.1
 Right of entry 104.3
 Transfer of ownership 107.6
 Vacant structures 108.2
 Voting of appeals board 111.2, 111.6

COMBUSTION

Combustion air 603.5

COMPONENT SERVICEABILITY

Unsafe conditions 306.1.1

CONDEMNATION

Closing of vacant structures 108.2
 Failure to comply 110.3
 General 108.1
 Notices and orders 108.2, 108.3
 Placarding 108.4
 Removal of placard 108.4.1

CONFLICT

Conflict of interest 111.2.3
 Violations 106.1

CONNECTION

Sewage system 506.1
 Water heating 505.4
 Water system 505.1

CONSTRUCTION

Existing structures 101.2

CONTAINER

Garbage 308.3.2
 Rubbish storage 308.2.1

CONTINUOUS

Unobstructed egress 702.1

CONTROL

Rodent control 302.5, 304.5
 Safety controls 603.4
 Weed 302.4

COOLING

Cooling towers 304.11

CORRIDOR

Accumulation of rubbish 308.1
 Light 402.2
 Lighting fixtures 605.3
 Obstructions 702.1, 702.2
 Ratings maintained 703

D

DAMP, DAMPNES

Roofs 304.7

Window, door frames304.13

DANGEROUS, HAZARDOUS

Condemnation108.1

Demolition. 110

Electrical hazards604.3, 604.3.1

Existing remedies102.4

Imminent danger. 202

Unsafe equipment 108.1.2

Unsafe structures or premises 108.1.5

DECKS

Handrails and guardrails.304.12

Maintenance 304.2, 304.10

DEMOLITION

Existing remedies102.4

Failure to comply110.3

General. 110

Order110.2

Salvage materials.110.4

DETECTORS

Smoke 704

DETERIORATION

Components of systems 306.1.1

Definition. 202

Exterior structure 304.1.1

Exterior walls304.6

DIRECT

Egress702.1

DISPOSAL

Disposal of garbage308.3

Disposal of rubbish.308.2

DOOR

Exit doors702.3

Fire703.2

Hardware304.15

Insect screens304.14

Interior surfaces305.3

Locks 304.15, 702.3

Maintenance. 304.13, 304.15

Weather tight304.13

Window and door frames304.13

DORMITORY (ROOMING HOUSE, HOTEL, MOTEL)

Locked doors702.3

Privacy 503.1, 503.2

DRAIN, DRAINAGE

Basement hatchways304.16

Plumbing connections 506

Storm drainage. 507

DUCT

Exhaust duct.304.9

Duct systems 607

DUST

Process ventilation 403.4

DWELLING

Cleanliness 305.1, 308.1

Definition. 202

Electrical 604.1

Heating facilities 602

Required facilities 502

E

EGRESS

Aisles 702.2

Emergency escape 702.4

General 702.1

Lighting 402.2

Locked doors 702.3

Obstructions prohibited. 702.1

Stairs, porches and railings. 304.10, 305.4, 305.5, 307.1

ELECTRIC, ELECTRICAL EQUIPMENT

Abatement of hazards, fire exposure 604.3.2

Abatement of hazards, water exposure 604.3.1

Condemnation. 108.1

Electrical equipment 604.3.1.1

Facilities required 604.1

Hazards. 604.3

Installation. 605.1

Lighting fixtures. 605.3

Receptacles 604.3, 605.2

Responsibility 601.2

Service 604.2

ELEVATOR, ESCALATORS, DUMBWAITERS

Condemnation. 108.1

General 606.1

Maintenance 606.1, 606.2

EMERGENCY

Emergency escape openings 702.4

Emergency measures. 109

Emergency orders. 109.1

ENFORCEMENT

Duties and powers 104

Scope 101.2

EQUIPMENT

Alternative. 105.2

Combustion air 603.5

Condemnation. 108.1.2, 108.3

Electrical installation 605.1

Emergency order 109.1

Energy conservation devices 603.6

Installation. 603.1

INDEX

Interior structure	305.1
Placarding	108.4, 108.5
Prohibited use	108.5
Responsibility	601.2
Safety controls	603.4
Scope	101.2
Scope, mechanical and electrical	601.1
Support, definition	202
Unsafe	108.1.2
Used	105.4

EXHAUST

Clothes dryer	403.5
Exhaust ducts	304.9
Process ventilation	403.4

EXISTING

Remedies	102.4
Scope	101.2
Structural members	304.1.1, 304.4
Structures	101.3

EXTERIOR

Decorative features	304.8
Exterior structure	304
Exterior walls	304.6
Painting	304.2, 304.6
Rodent harborage	302.5, 304.5
Sanitation	304.1
Scope	301.1
Stair	304.10
Street numbers	304.3
Unsafe conditions	304.1.1
Weather tight	304.13

F

FAN

Exhaust vents	302.6
-------------------------	-------

FEES, EXPENSES, COST

Closing vacant structures	108.2
Demolition	110.1, 110.3, 110.4
Extermination	309.2, 309.3, 309.4, 309.5
General	103.5
Relief from personal liability	103.4

FENCE

Accessory	302.7
Maintenance	304.2

FIRE

Automatic sprinkler systems	704.1.1
Fire-resistance-rated assemblies	703.1
Fire department connection	704.1.2
Fire protection systems	704
Responsibility, fire safety	701.2

Scope	101.2
Scope, fire safety	701.1
Smoke alarms	704.2

FLAMMABLE LIQUID

Containers	108.1.2
----------------------	---------

FLOOR, FLOORING

Area for sleeping purposes	404.4.1
Fire-resistance ratings	703.1
Interior surfaces	305.1, 305.3
Space requirements	404.4.1, 404.6

FOOD PREPARATION

Cooking equipment	403.3
Sanitary condition	305.1, 404.7
Ventilation	403.4

FOUNDATION

Condemnation	108.1.1
Foundation walls	304.5
Unsafe conditions	304.1.1, 305.1.1

FRAME

Window and door frames	304.13
----------------------------------	--------

G

GAS

Energy conservation devices	603.6
Exhaust vents	302.6

GLAZING

Materials	304.13.1
---------------------	----------

GRADE

Drainage	302.2, 507
--------------------	------------

GUARD

Anchorage and maintenance	304.12
Basement windows	304.18.2
Definition	202

H

HABITABLE

Definition	202
Light	402
Minimum ceiling height	404.3
Minimum room width	404.2
Required plumbing facilities	502
Residential heating facilities	602.2, 602.3
Space requirements	404.4.1
Ventilation	403

HANDRAILS AND GUARDRAILS

Handrails	304.12, 305.5, 307.1
Stairs and porches	304.10

HARDWARE

Door hardware	304.15, 702.3
Openable windows	304.13.2

HAZARDOUS (See DANGEROUS, HAZARDOUS)

HEAT, HEATING

Energy conservation devices 603.6
 Fireplaces 603.1
 Heating 603.1
 Mechanical equipment 603.1
 Required capabilities 602
 Residential heating 602.2, 602.3
 Supply 602.3
 Water heating facilities 505.4
 Water system 505

HEIGHT

Minimum ceiling height 404.3

HOT (See HEAT, HEATING)

HOTELS, ROOMING HOUSES AND DORMITORY UNITS, MOTELS

Definition 202
 Locked doors 702.3
 Required facilities 502
 Toilet rooms 503

HOUSEKEEPING UNIT

Definition 202

I

IDENTIFICATION

Code official 104.4

INFESTATION

Condemnation 108.1.3
 Definition 202
 Insect and rodent 302.5, 304.14, 309.1

INSECTS

Infestation 309.1
 Insect screens 304.14
 Pest elimination 309

INSPECTIONS

General 104.2
 Right of entry 104.3

INSPECTOR

Identification 104.4
 Inspections 104.2
 Records 104.6

INTENT

Code 101.3

INTERIOR

Interior structure 305
 Interior surfaces 305.3
 Means of egress 702
 Sanitation 305.1
 Unsafe conditions 305.1.1

J

JURISDICTION

Title 101.1

K

KITCHEN

Electrical outlets required 605.2
 Minimum width 404.2
 Prohibited use 404.4.4
 Room lighting 605.3
 Water heating facilities 505.4

L

LANDING

Handrails and guards 304.12, 305.5, 306.1
 Maintenance 304.10, 305.4

LAUNDRY

Room lighting 605.3
 Water-heating facilities 505.4

LAVATORY

Hotels 502.3
 Required facilities 502
 Rooming houses 502.2
 Sanitary drainage system 506
 Water-heating facilities 505.4
 Water system 505

LEASE (SELL, RENT)

Heat supplied 602.3
 Salvage materials 110.4
 Transfer of ownership 107.6

LIEN

Closing of vacant structures 108.2
 Demolition 110.3
 Failure to comply 110.3

LIGHT, LIGHTING

Common halls and stairways 402.2, 605.3
 General 402
 Habitable rooms 402.1
 Kitchen 605.3
 Laundry rooms 605.3
 Luminaires 605.3
 Other spaces 402.3
 Responsibility 401.2
 Scope 101.2
 Toilet rooms 605.3

LIVING ROOM

Room area 404.4.1

LOAD, LOADING

- Elevators, escalators and dumbwaiters 606.1
- Handrails and guardrails 304.12, 305.5
- Live load 304.4, 305.2
- Stairs and porches 304.10, 305.2
- Structural members 304.4, 305.2

M

MAINTENANCE

- Required 102.2

MATERIAL

- Alternative 105.2
- Salvage 110.4
- Used 105.4

MEANS OF EGRESS (See EGRESS)

MECHANICAL

- Installation 603.1
- Responsibility 601.2
- Scope 601.1
- Ventilation, general 403
- Ventilation, toilet rooms 403.2

MINIMUM

- Ceiling height 404.3
- Room area 404.4.1
- Room width 404.2

MODIFICATION

- Approval 105.1

MOTEL (See HOTELS)

MOTOR VEHICLES

- Inoperative 302.8
- Painting 302.8

N

NATURAL

- Lighting 401.3, 402
- Ventilation 401.3, 403

NOTICES AND ORDERS

- Appeal 111.1
- Form 107.2
- Method of service 107.3
- Orders 107
- Owner, responsible person 107.1
- Penalties 107.5
- Placarding of structure 108.4
- Transfer of ownership 107.6
- Unauthorized tampering 107.4
- Vacating structure 108.2

NOXIOUS

- Process ventilation 403.4
- Weeds 302.4

NUISANCE

- Closing of vacant structures 108.2

O

OBSTRUCTION

- Light 402.1
- Right of entry 104.3

OCCUPANCY (See USE)

OPENABLE

- Locked doors 702.3
- Windows 304.13.2, 403.1

OPERATOR

- Definition 202

ORDER (See NOTICE)

ORDINANCE, RULE

- Applicability 102
- Application for appeal 111.1

OUTLET

- Electrical 605.2

OWNER

- Closing of vacant structures 108.2
- Definition 202
- Demolition 110
- Failure to comply 110.3
- Insect and rat control 302.5, 309.2, 309.4
- Notice 107.1, 108.3
- Pest elimination 309.2
- Placarding of structure 108.4
- Responsibility 301.2
- Responsibility, fire safety 701.2
- Responsibility, light, ventilation 401.2
- Responsibility, mechanical and electrical 601.2
- Responsibility, plumbing facilities 501.2
- Right of entry 104.3
- Rubbish storage 308.2.1
- Scope 101.2
- Transfer of ownership 107.6

P

PASSAGEWAY

- Common hall and stairway 402.2
- Interior surfaces 305.3
- Toilet rooms, direct access 503.1

PENALTY

- Notices and orders 107.5
- Placarding of structure 108.4
- Prohibited occupancy 108.5
- Removal of placard 108.4.1
- Scope 101.2
- Violations 106.4

PEST ELIMINATION

Condemnation108.1
 Definition. 202
 Insect and rodent control 302.5, 304.5, 304.14, 309.1
 Pest elimination309.1
 Responsibility of owner. 301.2, 309.2
 Responsibility of tenant-occupant.309.3, 309.4, 309.5

PLACARD, POST

Closing108.2
 Condemnation108.1
 Demolition. 110
 Emergency, notice109.1
 Notice to owner. 107.1, 108.3
 Placarding of structure108.4
 Prohibited use.108.5
 Removal 108.4.1

PLUMBING

Clean and sanitary504.1
 Clearance504.2
 Connections505.1
 Contamination505.2
 Employee’s facilities503.3
 Fixtures504.1
 Required facilities 502
 Responsibility501.2
 Sanitary drainage system 506
 Scope501.1
 Storm drainage. 507
 Supply.505.3
 Water heating facilities505.4

PORCH

Handrails304.12
 Structurally sound.304.10

PORTABLE (TEMPORARY)

Cooking equipment.603.1

PRESSURE

Water supply.505.3

PRIVATE, PRIVACY

Bathtub or shower503.1
 Occupancy limitations.404.1
 Required plumbing facilities 502
 Sewage system506.1
 Water closet and lavatory503.1
 Water system505.1

PROPERTY, PREMISES

Cleanliness 304.1, 308.1
 Condemnation 108
 Definition. 202
 Demolition. 110
 Emergency measures. 109
 Exterior areas 302

Failure to comply. 110.3
 Grading and drainage. 302.2
 Pest elimination, multiple occupancy . . . 302.5, 309.4
 Pest elimination, single occupancy. . . . 302.5, 309.3
 Responsibility 301.2
 Scope 301.1
 Storm drainage 507
 Vacant structures and land. 301.3

PROTECTION

Basement windows. 304.17
 Fire protection systems. 704
 Signs, marquees and awnings 304.9

PUBLIC

Cleanliness304.1, 305.1
 Egress. 702.1
 Hallway 502.3
 Sewage system. 506.1
 Toilet facilities 502.5, 503
 Vacant structures and land 301.3
 Water system 505

PUBLIC WAY

Definition. 202

R

RAIN (PREVENTION OF ENTRY INTO BUILDING EXTERIOR ENVELOPE)

Basement hatchways 304.16
 Exterior walls. 304.6
 Grading and drainage. 302.2
 Roofs. 304.7
 Window and door frames 304.13

RECORD

Official records 104.6

REPAIR

Application of other codes. 102.3
 Chimneys 304.11
 Demolition. 110.1
 Exterior surfaces. 304.1
 Intent. 101.3
 Maintenance 102.2
 Signs, marquees and awnings 304.9
 Stairs and porches 304.10
 Weather tight. 304.13
 Workmanship 102.5

REPORTS

Test reports. 105.3.2

RESIDENTIAL

Pest elimination. 309
 Residential heating 602.2
 Scope 101.2

RESPONSIBILITY

Pest elimination 309
 Fire safety 701.2
 Garbage disposal 308.3
 General 301.2
 Mechanical and electrical 601.2
 Persons 301.1
 Placarding of structure 108.4
 Plumbing facilities 501.2
 Rubbish storage 308.2.1
 Scope 101.2, 301.1

REVOKE, REMOVE

Demolition 110
 Existing remedies 102.4
 Removal of placard 108.4.1
 Rubbish removal 308.2.1

RIGHT OF ENTRY

Duties and powers of code official 104.3
 Inspections 104.2

RODENTS

Basement hatchways 304.16
 Condemnation 108
 Foundations 304.5
 Guards for basement windows 304.17
 Harborage 302.5
 Insect and rodent control 309.1
 Pest elimination 302.5, 309

ROOF

Exterior structure 304.1
 Roofs 304.7
 Storm drainage 507

ROOM

Bedroom and living room 404.4
 Cooking facilities 403.3
 Direct access 503.2
 Habitable 402.1
 Heating facilities 602
 Light 402
 Minimum ceiling heights 404.3
 Minimum width 404.2
 Overcrowding 404.5
 Prohibited use 404.4.4
 Temperature 602.5
 Toilet 503
 Ventilation 403

ROOMING HOUSES (See DORMITORY)

RUBBISH

Accumulation 308.1
 Definition 202

Disposal 308.2
 Garbage facilities 308.3.1
 Rubbish storage 308.2.1

S

SAFETY, SAFE

Fire safety requirements 701, 702, 703, 704
 Safety controls 603.4

SANITARY

Cleanliness 304.1, 305.1
 Disposal of garbage 308.3
 Disposal of rubbish 308.2
 Exterior property areas 302.1
 Exterior structure 304.1
 Food preparation 404.7
 Furnished by occupant 302.1
 Grease interceptors 506.3
 Interior surfaces 305.3
 Plumbing fixtures 504.1
 Required plumbing facilities 502
 Scope 101.2

SCREENS

Insect screens 304.14

SECURITY

Basement hatchways 304.18.3
 Building 304.18
 Doors 304.18.1
 Vacant structures and land 301.3
 Windows 304.18.2

SELF-CLOSING SCREEN DOORS

Insect screens 304.14

SEPARATION

Fire-resistance ratings 703
 Privacy 404.1
 Separation of units 404.1

SERVICE

Electrical 604.2
 Method 107.3
 Notices and orders 107.1, 108.3
 Service on occupant 108.3

SEWER

General 506.1
 Maintenance 506.2

SHOWER

Bathtub or shower 502.1
 Rooming houses 502.2
 Water-heating facilities 505.4
 Water system 505

SIGN
 Signs, marquees and awnings304.9
 Unauthorized tampering107.4

SINGLE-FAMILY DWELLING
 Extermination 309

SINK
 Kitchen sink502.1
 Sewage system 506
 Water supply505.3

SIZE
 Efficiency unit404.6
 Habitable room, light. 402
 Habitable room, ventilation 403
 Room area 404.4.1

SMOKE ALARMS
 Alarms704.2
 Installation near bathrooms 704.2.2
 Installation near cooking appliances. 704.2.1
 Interconnection704.4
 Power source704.3

SPACE
 General, light 402
 General, ventilation. 403
 Occupancy limitations. 404
 Privacy404.1
 Scope401.1

STACK
 Smoke304.11

STAIRS
 Common halls and stairways, light.402.2
 Exit facilities305.4
 Exterior property areas302.3
 Handrails 304.12, 305.5
 Lighting605.3
 Stairs and porches304.10

STANDARD
 Referenced102.7

STOP WORK ORDER
 Authority112.1
 Emergencies.112.3
 Failure to comply112.4
 Issuance112.2

STORAGE
 Food preparation404.7
 Garbage storage facilities.308.3
 Rubbish storage facilities 308.2.1
 Sanitation308.1

STRUCTURE
 Accessory structures302.7
 Closing of vacant structures108.2
 Definition. 202

Emergency measures 109
 General, condemnation. 110
 General, exterior 304.1
 General, interior structure 305.1
 Placarding of structure 108.4
 Scope 301.1
 Structural members. 304.4, 305.2
 Vacant structures and land 301.3

SUPPLY
 Combustion air 603.5
 Public water system 505.1
 Water-heating facilities 505.4
 Water supply 505.3
 Water system 505

SURFACE
 Exterior surfaces 304.2, 304.6
 Interior surfaces 305.3

SWIMMING
 Enclosure 303.2
 Safety covers 303.2
 Swimming pools 303.1

T

TEMPERATURE
 Nonresidential structures 602.4
 Residential buildings. 602.2
 Water-heating facilities 505.4

TENANT
 Scope 101.2

TEST, TESTING
 Agency 105.3.1
 Methods 105.3.1
 Reports 105.3.2
 Required 105.3

TOXIC
 Process ventilation 403.4

TRASH
 Rubbish and garbage 308

U

UNOBSTRUCTED
 Access to public way. 702.1
 General, egress 702.1

UNSAFE STRUCTURES AND EQUIPMENT
 Abatement methods 108.6
 Dangerous structure or premises 108.1.5
 Equipment. 108.1.2
 Existing remedies 102.4
 General, condemnation. 108, 110
 General, demolition. 110

INDEX

Notices and orders	107, 108.3
Record	108.7
Structures	108.1.1

USE

Application of other codes	102.3
General, demolition	110

UTILITIES

Authority to disconnect	108.2.1
-----------------------------------	---------

V

VACANT

Abatement methods	108.6
Authority to disconnect service utilities	108.2.1
Closing of vacant structures	108.2
Emergency measure	109
Method of service	107.3, 108.3
Notice to owner or to person responsible	107, 108.3
Placarding of structure	108.4
Record	108.7
Vacant structures and land	301.3

VAPOR

Exhaust vents	302.6
-------------------------	-------

VEHICLES

Inoperative	302.8
Painting	302.8

VENT

Plumbing hazard	504.3
Exhaust vents	302.6
Flue	603.2

VENTILATION

Clothes dryer exhaust	403.5
Combustion air	603.5
Definition	202
General, ventilation	403
Habitable rooms	403.1
Process ventilation	403.4
Recirculation	403.2, 403.4
Toilet rooms	403.2

VERMIN

Condemnation	108
Insect and rodent control	302.5, 309

VIOLATION

Condemnation	108
Enforcement	106.2
General	106
Notice	107, 108.3
Separate offenses	106.4
Placarding of structure	108.4

Prosecution	106.3
Strict liability offense	106.3, 202
Transfer of ownership	107.6

W

WALK

Sidewalks	302.3
---------------------	-------

WALL

Accessory structures	302.7
Exterior surfaces	304.2, 304.6
Exterior walls	304.6
Foundation walls	304.5
General, fire-resistance rating	703.1
Interior surfaces	305.3
Outlets required	605.2
Temperature measurement	602.5

WASTE

Disposal of garbage	308.3
Disposal of rubbish	308.2
Garbage storage facilities	308.3.1

WATER

Basement hatchways	304.16
Connections	506.1
Contamination	505.2
General, sewage	506
General, storm drainage	507
General, water system	505
Heating	505.4
Hotels	502.3
Kitchen sink	502.1
Required facilities	502
Rooming houses	502.2
Supply	505.3
System	505
Toilet rooms	503
Water-heating facilities	505.4

WEATHER, CLIMATE

Heating facilities	602
------------------------------	-----

WEEDS

Noxious weeds	302.4
-------------------------	-------

WIDTH

Minimum room width	404.2
------------------------------	-------

WINDOW

Emergency escape	702.4
Glazing	304.13.1
Guards for basement windows	304.17
Habitable rooms	402.1
Insect screens	304.14
Interior surface	305.3

Light 402
Openable windows 304.13.2
Toilet rooms 403.2
Ventilation 403
Weather tight 304.13
Window and door frames 304.13
WORKMANSHIP
General 102.5



Special Inspection Program for Building Departments

Building departments can approve special inspection agencies with confidence, at no cost, with help from IAS.

- Ensures IBC Chapter 17 Compliance
- Standardizes Inspections
- Easy to Use
- Saves Time
- Shows Due Diligence
- Cost Effective



**FOR MORE INFORMATION:
1-866-427-4422
www.iasonline.org/si**

Part of the Accreditation Suite for Building Departments

14-09059



At ICC Plan Review Services, our code experts love a good challenge

Like reviewing your most complex plan reviews.

Our licensed and ICC-certified code experts specialize in delivering the most accurate code analysis to your most complex and complicated projects. After all, no other plan review firm has as much expertise in **ALL** the International Codes (I-Codes) as the code experts at ICC Plan Review Services.

For I-Codes expertise you can trust, visit the ICC Plan Review web page at www.iccsafe.org/PLRF2 or call David Hunter at 888-422-7233, ext. 5577.



**INTERNATIONAL
CODE COUNCIL®**

People Helping People Build a Safer World®

The International Code Council's Training and Education Department

Industry professionals look to ICC to provide the critical knowledge and experiences necessary to excel in today's challenging world. ICC's educational programs cover a broad spectrum of code and construction related topics, offering some of the highest quality instruction direct from the source.

INSTITUTES

Acquire Skills, Share Experiences, Earn CEUs

ICC's training institutes offer a comprehensive education experience and a great way to earn much needed CEUs. Learn best practices from the leading experts in the field, build your network of professional contacts and share experiences. Institutes are held across the country throughout the year. To see the full schedule go to www.iccsafe.org/training.

HIRE ICC TO TEACH

Bring ICC On-Site and Earn CEUs

Give your group the confidence they need to meet tough challenges head-on so they can reach their full potential. ICC's course catalog contains a wide variety of educational topics that are available for contract at a location of your choice. Customized training is also available to fit your needs. For our full course catalogue go to www.iccsafe.org/hireicc.

ICC ONLINE CAMPUS

Earn CEUs at Your Own Pace

Online courses offer access to a comprehensive training and education portal, providing you with an effective and convenient tool to enhance your professional skills. Courses are available anytime for 99 days following registration. For a quick and easy way to earn CEUs towards your certification, try our Online Certifications Renewal section. Go to www.iccsafe.org/onlinecampus for our full offerings.

For more information about ICC's Training please contact us at
888-ICC-SAFE (422-7233) ext. 33818 or email us at icctraining@iccsafe.org.



People Helping People Build a Safer World®

Growing your career is what ICC Membership is all about

As your building career grows, so does the need to expand your code knowledge and job skills. Whether you're seeking a higher level of certification or professional quality training, Membership in ICC offers the best in I-Code resources and training for growing your building career today and for the future.

- **Learn** new job skills to prepare for a higher level of responsibility within your organization
- **Improve** your code knowledge to keep pace with the latest International Codes (I-Codes)
- **Achieve** additional ICC Certifications to open the door to better job opportunities

Plus, an affordable ICC Membership provides exclusive Member-only benefits including:

- Free code opinions from I-Code experts
- Free I-Code book(s) to new Members*
- Access to employment opportunities in the ICC Career Center
- Discounts on professional training & Certification renewal exams
- Savings of up to 25% off on code books & training materials
- Free benefits - Governmental Members: Your staff can receive free ICC benefits too*
- And much more!

Join the International Code Council (ICC) and start growing your building career now! Visit our Member page at www.iccsafe.org/membership for an application.

*Some restrictions apply. Speak with an ICC Member Services Representative for details.

14-09333

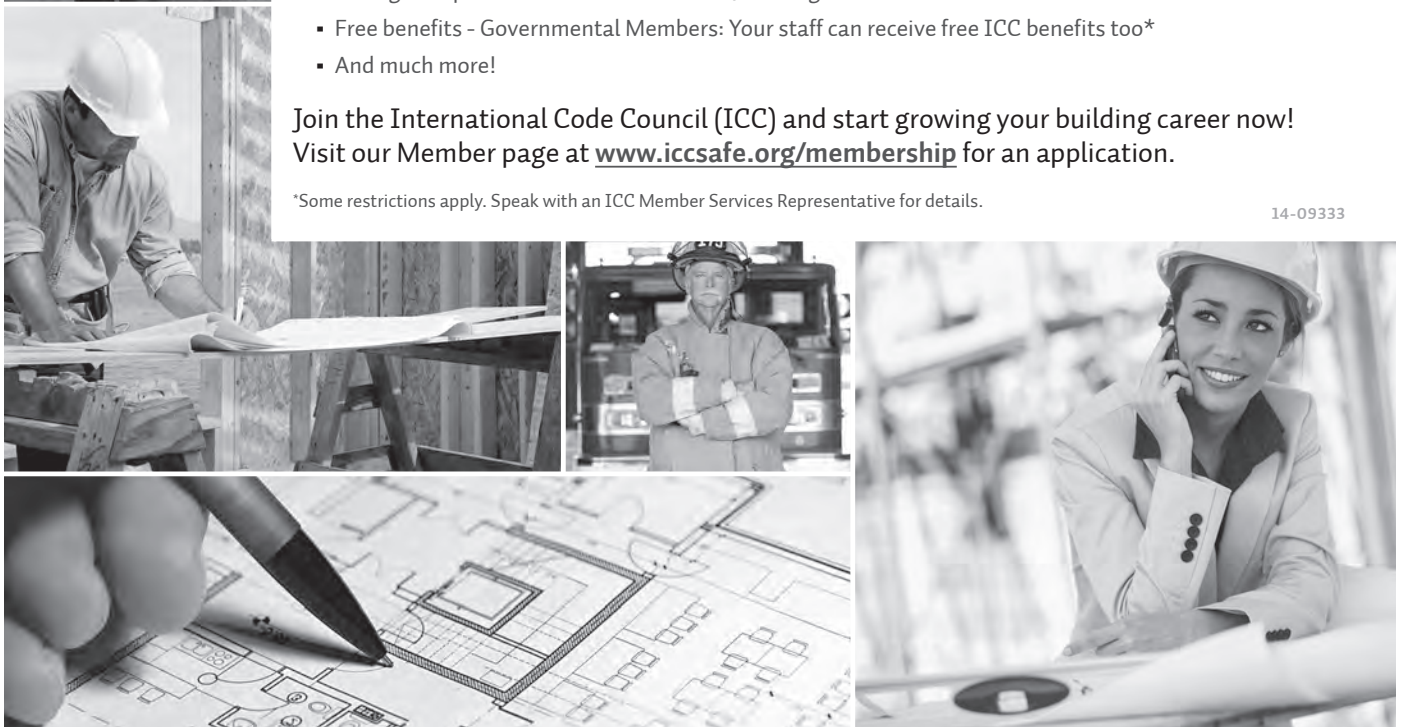

**ORDINANCE OF THE CITY COUNCIL OF JACKSON, MISSISSIPPI
AMENDING SECTION 66-44 OF THE CODE OF ORDINANCES OF
JACKSON, MISSISSIPPI TO REVISE PROCEDURES FOR PROVIDING
NOTICE, HEARING, ASSESSING COSTS AND PENALTIES AND TO
ENACT CRIMINAL PENALTIES FOR REPEATED VIOLATIONS
RESULTING IN THE CLEANING OF PROPERTY CONSIDERED TO
CONSTITUTE A MENACE TO PUBLIC HEALTH, SAFETY, AND
WELFARE.**

WHEREAS, Section 21-19-11 of the Mississippi Code authorizes municipalities to utilize public resources to clean property which constitutes a menace to public health, safety, and welfare when owners failed to address the conditions; and

WHEREAS, Section 21-19-11 of the Mississippi Code sets forth the procedures for providing notice, hearing, and assessing costs and penalties for the cleaning of property considered to constitute a menace to public health, safety, and welfare; and

WHEREAS, Section 21-19-11 of the Mississippi Code provides that the procedures set forth in the statute does not prevent a municipality from enacting *criminal* penalties for failure to maintain property so as not to constitute a menace to public health, safety, and welfare; and

WHEREAS, the best interest of the municipality would be served by the criminal prosecution of owners whose property has been adjudicated to be a menace to public health, safety, and welfare on multiple occasions;

THEREFORE, BE IT ORDAINED by the City Council of Jackson, that Section 66-44 is hereby amended to read as follows:

Sec. 66-44. - Cleaning private property; *civil* debt; lien; criminal proceedings.

- (a) *Notice; hearing; abatement; lien.* To determine whether property or a parcel of land located within a municipality is in such a state of uncleanness as to be a menace to public health, safety, and welfare of the community, a hearing shall be conducted upon

the motion of the City or upon the receipt of a petition signed by a majority of the residents residing within four hundred (400) feet of any property or parcel of land alleged to be in need of the cleaning. Notice shall be provided to the property owner in accordance with the procedures set forth in Section 21-19-11 of the Mississippi Code which requires the following:

- (1) United States mail two (2) weeks before the date of the hearing mailed to the address of the subject property and to the address where the ad valorem tax notice for such property is sent by the office charged with collecting ad valorem tax; and
- (2) Posting notice for at least two (2) weeks before the date of a hearing on the property or parcel of land alleged to be in need of cleaning and at city hall or another place in the municipality where such notices are posted.

Any notice required by this section shall include language that informs the property owner that an adjudication at the hearing that the property or parcel of land is in need of cleaning will authorize the municipality to reenter the property or parcel of land for a period of one (1) year after final adjudication without any further hearing if notice is posted on the property or parcel of land and at city hall or another place in the municipality where such notices are generally posted at least seven (7) days before the property or parcel of land is reentered for cleaning. A copy of the required notice mailed and posted as required by this section shall be recorded in the minutes of the Jackson City Council in conjunction with the hearing required by this section.

If there is an adjudication that the property or parcel of land in its current condition constitutes a menace to public health, safety and welfare of the community, the property shall be cleaned if the owner does not do so himself. The use of municipal employees or contract labor may be used to clean the property. Cleaning shall consist of cutting grass and weeds; filling cisterns; removing rubbish, abandoned or dilapidated fences, outside toilets, abandoned or dilapidated buildings, slabs, personal property, which removal of personal property shall not be subject to the provisions of Section 21-39-21, and other debris; and draining cesspools and standing water therefrom. The City may by resolution adjudicate the actual cost of cleaning the property and may also impose a penalty not to exceed One Thousand Five Hundred Dollars (\$ 1,500.00) or

fifty percent (50%) of the actual cost, whichever is more. The cost and any penalty may become a civil debt against the property owner, and/or, at the option of the governing authority, an assessment against the property. The "cost assessed against the property" means either the cost to the municipality of using its own employees to do the work or the cost to the municipality of any contract executed by the municipality to have the work done, and administrative costs and legal costs of the municipality. For subsequent cleaning within the one-year period after the date of the hearing at which the property or parcel of land was adjudicated in need of cleaning, upon seven (7) days' notice posted both on the property or parcel of land adjudicated in need of cleaning and at city hall or another place in the municipality where such notices are generally posted, and consistent with the municipality's adjudication as authorized in this subsection (1), the City may reenter the property or parcel of land to maintain cleanliness without further notice or hearing no more than six (6) times in any twelve-month period with respect to removing abandoned or dilapidated buildings, slabs, dilapidated fences and outside toilets, and no more than twelve (12) times in any twenty-four-month period with respect to cutting grass and weeds and removing rubbish, personal property and other debris on the land, and the expense of cleaning of the property, except as otherwise provided in this section for removal of hazardous substances, shall not exceed an aggregate amount of Twenty Thousand Dollars (\$ 20,000.00) per year, or the fair market value of the property subsequent to cleaning, whichever is more. The aggregate cost of removing hazardous substances will be the actual cost of such removal to the municipality and shall not be subject to the Twenty Thousand Dollar (\$ 20,000.00) limitation provided in this subsection. The City may assess the same penalty for each time the property or land is cleaned as otherwise provided in this section. The penalty provided herein shall not be assessed against the State of Mississippi upon request for reimbursement under Section 29-1-145, nor shall the City clean a parcel owned by the State of Mississippi without first giving notice.

- (b) Assessment of costs and penalties. If the city council declares, by resolution, that the cost and any penalty shall be collected as a *civil* debt, then a suit on open account against the owner of the property shall be filed in a court of competent jurisdiction in the manner provided by law for the cost and any penalty, plus court costs, reasonable attorney's fees and interest from the date that the property was cleaned. If the city

council declares that the cost and any penalty shall be collected as an assessment against the property, then the assessment above provided for shall be a lien against the property and may be enrolled in the office of the circuit clerk of the county as other judgments are enrolled, and the tax collector of the municipality shall, upon order of the city council proceed to sell the land to satisfy the lien as now provided by law for the sale of lands for delinquent municipal taxes. The lien against the property shall be an encumbrance upon the property and shall follow title of the property.

(i) All assessments levied under the provisions of this section shall be included with municipal ad valorem taxes and payment shall be enforced in the same manner in which payment is enforced for municipal ad valorem taxes, and all statutes regulating the collection of other taxes in the City will apply to the enforcement and collection of the assessments levied under the provisions of this section, including utilization of the procedures authorized under Sections 17-13-9(2) and 27-41-2.

(ii) All assessments levied under the provisions of this section shall become delinquent at the same time municipal ad valorem taxes become delinquent. Delinquencies shall be collected in the same manner and at the same time delinquent ad valorem taxes are collected and shall bear the same penalties as those provided for delinquent taxes. If the property is sold for the nonpayment of an assessment under this section, it shall be sold in the manner that property is sold for the nonpayment of delinquent ad valorem taxes. If the property is sold for delinquent ad valorem taxes, the assessment under this section shall be added to the delinquent tax and collected at the same time and in the same manner.

(c) *Criminal Penalties.* Prior to consideration by the city council of the adoption of a resolution declaring that certain parcels are in such a state of uncleanness as to be a menace to the public health and safety of the community, the Division of Community Improvement shall certify that an adjudication for the same violation involving the same parcel and same property owner has occurred no more than twice. If the same parcel and same property owner have been part of an adjudication at least twice within a two (2) year period, then the code enforcement officer is authorized to also submit a charging affidavit, indictment or bill of information regarding repeated violations to the City prosecutor, and the punishment shall constitute fine, imprisonment, or both as allowed by law, pursuant to § 21-19-11 of the Mississippi Code.

- (d) *Appeal.* All decisions rendered under the provisions of this section may be appealed in the same manner as other appeals from municipal boards or courts are taken.

Agenda Item #: _____
Date: June 27, 2017
By: Tyrone C. Hendrix
Margaret Barrett-Simon
De'Keither Stamps

AP759

Minute Book Summary - Accounts Payable

AGENDA DATE: JUNE 27, 2017

OFFICE OF THE CITY ATTORNEY
6/22/17

ORDER APPROVING CLAIMS NUMBERED 9943 TO
APPEARING AT PAGES 1474 TO , INCLUSIVE
THEREON, ON MUNICIPAL 'DOCKET OF CLAIMS', IN THE
AMOUNT OF \$3,478,561.86, AND MAKING
APPROPRIATION FOR THE PAYMENT THEREOF.

IT IS HEREBY ORDERED THAT CLAIMS NUMBERED TO , APPEARING AT
PAGES TO , INCLUSIVE THEREON, IN THE MUNICIPAL 'DOCKET OF
CLAIMS', IN THE AGGREGATE AMOUNT OF \$3,478,561.86, ARE
HEREBY APPROVED FOR PAYMENT AND SAID AMOUNT IS EXPRESSLY APPROPRIATED FOR THE
IMMEDIATE PAYMENT THEREOF.

IT IS FURTHER ORDERED THAT THERE IS APPROPRIATED FROM THE VARIOUS
FUNDS THE SUMS NECESSARY TO BE TRANSFERRED TO OTHER FUNDS FOR THE PURPOSE OF
PAYING THE CLAIMS AS FOLLOWS:

FROM:	TO ACCOUNT'S PAYABLE FUND
09 TAX INCREMENT BD FD \$1.6M	850.00
1% INFRASTRUCTURE TAX	319,662.18
AMERICORP CAPITAL CITY REBUILD	429.06
EARLY CHILDHOOD (DAYCARE)	70,396.77
FIRE PROTECTION	45,976.17
G O PUB IMP CONS BD 1998(\$35M)	5,000.00
G O PUB IMP CONS BD 2003(\$20M)	46,275.00
GENERAL FUND	661,295.99
HAIL DAMAGE MARCH 2013	278.00
HOME PROGRAM FUND	708.00
HOUSING COMM DEV ACT (CDBG) FD	74,181.96
JXN CONVENTION & VISITORS BUR	294,271.19
LANDFILL/SANITATION FUND	165,298.54
MADISON SEWAGE DISP OP & MAINT	21,967.99
P E G ACCESS- PROGRAMMING FUND	8,068.71
PARKS & RECR. FUND	55,217.70
RESURFACING -REPAIR & REPL. FD	45,717.81
RIDGELAND-WEST SEWAGE DISP O&M	3,917.94
SEIZURE & FORFEITED PROP-STATE	20,217.57
STATE TORT CLAIMS FUND	3,972.00
TECHNOLOGY FUND	60,046.39
TITLE III AGING PROGRAMS	27,093.00
TRAFFIC - REPAIR & REPL FD	621.98
TRANSPORTATION FUND	403,316.14
WATER SEWER B&I FD 2013 \$89.9M	5,750.00
WATER/SEWER CAPITAL IMPR FUND	744,717.79
WATER/SEWER OP & MAINT FUND	367,677.37
WATER/SEWER REVENUE FUND	2,211.61
WIRELESS RADIO COMMUNCATN FUND	23,425.00
	3,478,561.86

APPROVED FOR AGENDA

	INITIALS	DATE
DEPARTMENT DIRECTOR	<u>MBD</u>	<u>6/22/17</u>
LEGAL	<u>[Signature]</u>	<u>6/22/17</u>
CAO	<u>[Signature]</u>	<u>6/22/17</u>
MAYOR'S OFFICE	<u>[Signature]</u>	<u>6/22/17</u>
ITEM#	<u>6</u>	
AGENDA DATE	<u>06/27/17</u>	
BY: DAY, YARBER		

Office of the City Attorney
455 East Capitol Street

Post Office Box 2779
Jackson, Mississippi 39207-2779
Telephone: (601) 960-1799
Facsimile: (601) 960-1756

OFFICE OF THE CITY ATTORNEY

The CLAIMS DOCKET for June 27, 2017 in the aggregate
amount of 3,498,561.86 has been reviewed by me, based on
information and belief, is legally sufficient for payment authorization and placement in
NOVUS Agenda.

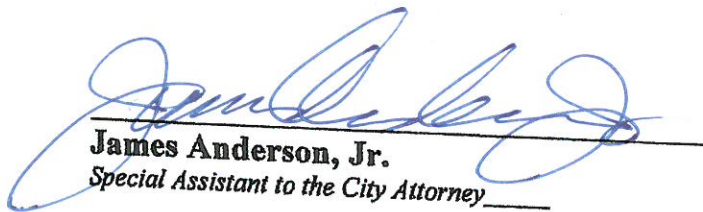
James Anderson, Jr.
Special Assistant to the City Attorney

6/22/17
DATE

OFFICE OF THE CITY ATTORNEY
6/22/17

AP755
 VENDOR PAYMENTS / FOR CLAIM DOCKET - 06/27/2017
 Report Title - AMOUNTS (DESCENDING) ALL TYPES
 Invoice Payments Over \$5,000

OFFICE OF THE CITY ATTORNEY
 6/21/17

VEN#	VENDOR-NAME	INVOICE	INV-DATE	AMOUNT	AUTHORIZATION	DUE-DATE	REF-NUMBER	PAYMENT-TYPE	REMARKS
71755	NATIONAL EXPRESS TRANSIT CORP	91440936	05/10/2017	\$316,328.17		06/27/2017		R&R-Invoice	MONTHLY FIXED COST
	187 565106425	PLANNING & DEVELOPMENT		\$376,328.17					
71963	PSI-GA, LLC	011	06/05/2017	\$364,694.74		06/27/2017		Contract-PO	011
	32 52290505009016485	PUBLIC WORKS		\$364,694.74					BIOSOLID SCREENING
	CI 44 BIOSOLIDS SCREENING, LOADING, TRANSPORTATION AND DISPOSAL			\$3,500,000.00	Pt Invoiced				
	001 BIOSOLIDS SCREENING, LOADING,			\$294,271.19		06/27/2017		R&R-Invoice	JUNE 2017 HOTEL/MOTEL SALES TAX
52712	METRO JACKSON CONVENTION & VIS	06142017	06/14/2017	\$294,271.19		06/27/2017		Contract-PO	CJ-05
	203 559006771	GENERAL GOVERNMENT		\$249,604.51		06/27/2017			
20570	HEMPHILL CONST. CO.	CJ-05	05/08/2017	\$249,604.51		06/27/2017		Contract-PO	WEST BANK PHS
	32 52290205057056485	PUBLIC WORKS		\$3,511,736.00	Pt Invoiced				
	CJ 8 WEST BANK INTERCEPTOR SEWER REHAB PH 5			\$201,749.58		06/27/2017		Contract-PO	1
09783	KEY CONSTRUCTORS INC	1	05/31/2017	\$201,749.58		06/27/2017		Contract-PO	ROBINSON ROAD BRIDGE
	173 451355B45034016485	PUBLIC WORKS		\$776,803.55					
	CJ 43 ROBINSON ROAD BRIDGE REPLACEMENT			\$150,633.50	Pt Invoiced	06/27/2017		R&R-Invoice	0003259-0148-6
43122	WASTE MANAGEMENT OF MS INC	0706737	06/01/2017	\$150,633.50		06/27/2017		Contract-PO	JBM 16-08
	9 455106426	PUBLIC WORKS		\$88,539.86		06/27/2017	19738418	UTILITY-PAYM	DISPOSAL CONTRACT
20377	ENERGY	19738145\	06/27/2017	\$88,539.86		06/27/2017			
	31 521356451	PUBLIC WORKS		\$71,488.56		06/19/2017			
	0+1978145	PUBLIC WORKS		\$45,652.68		06/27/2017		Contract-PO	ELECTRIC LIGHT AND POWER
71086	CSL SERVICES INC	JBM 16-08	05/31/2017	\$45,652.68		06/27/2017		Contract-PO	JBM 16-08
	31 522306419	PUBLIC WORKS		\$21,917.94					BILLING METER INSTALLATION AND MAINT
	174 944006419	PUBLIC WORKS		\$3,917.94					
	175 945106419	PUBLIC WORKS		\$110,083.54					
	CJ 15 BILLING METER INSTALLATION & MAINTENANCE			68,083.540	Invoiced				
	001 BILLING METER INSTALLATION & M			30,000.000	Invoiced				
	002 BILLING METER INSTALLATION & M			12,000.000	Pt Invoiced				
15614	SOUTHERN CONSULTANTS INC	3082	06/02/2017	\$61,647.00		06/27/2017		Contract-PO	3082
	32 52290205057046413	PUBLIC WORKS		\$61,647.00					WEST BANIN INTERCEPTOR PH 4 &
	CH 6 WEST BANK INTERCEPTOR REHAB, PH4 & 5, PROJ. 20505-704			\$1,842,095.00	Pt Invoiced				5
	001 WEST BANK INTERCEPTOR REHAB. P			\$60,281.29		06/27/2017		R&R-Invoice	6967 7294 8648 8786 8787 8935
69303	CAPITAL CITY SECURITY INC	6967	06/14/2017	\$60,281.29		06/27/2017		R&R-Invoice	8983 SECURITY SERVICES
	81 598106420	HUMAN & CULTURAL SERVICES		\$50,606.36		06/27/2017		R&R-Invoice	FUEL
48050	FLEETCOR TECHNOLOGIES	NP50616589	06/12/2017	\$50,606.36		06/27/2017		Contract-PO	0013739
	1 2390	Liabilities		\$44,295.49		06/27/2017			FIRE STATION 20
64274	CANIZARO CANTHON DAVIS	0013739	05/23/2017	\$44,295.49		06/27/2017		Contract-PO	0013739
	85 921105B70034016485	PLANNING & DEVELOPMENT		\$183,182.00					
	CJ 38 FIRE STATION 20 BLDG			\$183,182.00	Pt Invoiced				
	001 FRIE STATION 20 BLDG			\$183,182.00					

VENDOR PAYMENTS / FOR CLAIM DOCKET - 06/27/2017
 Report Title - AMOUNTS (DESCENDING) ALL TYPES
 Invoice Payments Over \$5,000

OFFICE OF THE CITY ATTORNEY
 JESSIE GIBBS
 6/21/17

VEN#	VENDOR-NAME	INVOICE	INV-DATE	AMOUNT	AUTHORIZATION	DUE-DATE	REF-NUMBER	PAYMENT-TYPE	REMARKS
70176	STANTEC CONSULTING SERVICES	1202427	05/31/2017	\$43,634.51		06/27/2017		Contract-PO	1202427
	213 451355B40087016413	PUBLIC WORKS		\$43,634.51					MILL ST REHAB
CJ	35 MILL STREET PROJECT			\$97,747.02					
	001	MILL STREET PROJECT		97,747.02	Pt Invoiced	\$97,747.02		Regular-PO	WILL CLEAN ALL DUCT (NEW AND INDOOR COOLING COIL TO HELP OLD) ADD UV LIGHTS TO THE KILL ANY MOLD OR MILDEW THAT
72113	Service Experts Heating & A/C	166424	04/03/2017	\$41,350.00		06/27/2017			
	10 509006419	FIRE DEPARTMENT		\$41,350.00					

PJ	681 Cleaning Air Duct System @ Fire Stations	(Quote) Station 3: We will cle		\$41,350.00					
001	Station 3: We will cle			1,000	Received	\$1,450.00			
002	Station 5: We will clean the s			1,000	Received	\$1,700.00			
003	Station 6: We will clean all d			1,000	Received	\$1,700.00			
004	Station 10: We will clean the			1,000	Received	\$1,450.00			
005	Station 10 Museum: We will cle			1,000	Received	\$2,100.00			
006	Station 15: We will clean all			1,000	Received	\$2,100.00			
007	Station 28: We will clean the			1,000	Received	\$2,500.00			
008	Station 11: Both systems have			1,000	Received	\$1,900.00			
009	Station 12: We will clean all			1,000	Received	\$1,700.00			
010	Station 14: We will clean the			1,000	Received	\$2,100.00			
011	Station 22: We will clean all			1,000	Received	\$1,800.00			
012	Station 23: We will clean all			1,000	Received	\$1,900.00			
013	Station 24: The complete duct			1,000	Received	\$1,800.00			
014	Station 25: The complete ductw			1,000	Received	\$2,100.00			
015	Station 7: The complete ductwo			1,000	Received	\$1,900.00			
016	Station 16: The complete ductw			1,000	Received	\$1,900.00			
017	Station 17: There is a lot of			1,000	Received	\$1,450.00			
018	Station 19: Both systems have			1,000	Received	\$2,100.00			
019	Station 20: Lots of growth on			1,000	Received	\$1,700.00			
020	Station 21: We will clean all			1,000	Received	\$1,900.00			
021	Station 26: We will clean the			1,000	Received	\$1,700.00			
022	Station 12 Additional: Station			1,000	Received	\$2,400.00			

70043	RETRO METRO LLC	06152017	06/15/2017	\$40,583.34		06/27/2017		R&R-Invoice	JULY 2017 RENTAL SPACE FOR METROCENTER MALL
31	520106512	PUBLIC WORKS		\$14,857.57					
1	442426512	PUBLIC SAFETY - POLICE		\$3,982.19					
300	443466512	GENERAL GOVERNMENT		\$6,901.94					
5	501106512	PARKS & RECREATION		\$2,871.96					
1	413006512	PERSONNEL		\$3,850.78					
1	433006512	HUMAN & CULTURAL SERVICES		\$8,118.90					
48050	FLEETCOR TECHNOLOGIES	NP50650269	06/19/2017	\$40,503.77		06/27/2017		R&R-Invoice	FUEL
	1 2390	Liabilities		\$40,503.77					
70705	ELECTION SYSTEMS & SOFTWARE	1010734	06/06/2017	\$40,107.00		06/27/2017		R&R-Invoice	2017 MUN PRIMARY ELECTION PROJECT MANAGEMENT
	1 402206419	GENERAL GOVERNMENT		\$40,107.00					

AP755 VENDOR PAYMENTS / FOR CLAIM DOCKET - 06/27/2017
 Report Title - AMOUNTS (DESCENDING) ALL TYPES
 Invoice Payments Over \$5,000

VEN#	VENDOR-NAME	INVOICE	INV-DATE	AMOUNT	AUTHORIZATION	DUE-DATE	REF-NUMBER	PAYMENT-TYPE	REMARKS
68600	AMY SOJOURNER INC.	CJ04281	04/28/2017	\$40,036.64		06/27/2017		Regular-PO	05/02/17 ELECTION SUPPORT
		Assets		\$40,036.64					
		1 1502		\$40,036.64					
		PJ 278 CLAY GRAVEL TERM BID # 75078-051016		5,004.580	Received				
		001 *C02269 (TERM BID) CLAY GRAVEL		\$40,036.64					
B2002	MITCHELL ALICIA	06152017	06/15/2017	\$38,430.00		06/27/2017		R&R-Invoice	RENT SUPPLEMENT PAYMENT
		148 448909150009016723		\$38,430.00					DOWN PAYMENT
		PUBLIC WORKS		\$38,068.35					
		16149130\		\$38,068.35					
20377	ENTERGY	16149130\	06/27/2017	\$38,068.35		06/27/2017	16151102	UTILITY-PAYM	
		31 521306451		\$38,068.35					
		PUBLIC WORKS		\$35,208.69					
		0+16149130 31 521306451		\$35,208.69		06/19/2017	0.1	\$38,068.35	ELECTRIC LIGHT AND POWER
48050	ELEETCOR TECHNOLOGIES	NP 50574478	06/05/2017	\$35,208.69		06/27/2017		R&R-Invoice	FUEL
		1 2390		\$35,000.00					
		Liabilities		\$35,000.00					
		GRANT-3		\$35,000.00					
60405	STEMPOT COMMUNITY SERVICES	HUMAN & CULTURAL SERVICES	05/03/2017	\$35,000.00		06/27/2017		R&R-Invoice	2016/2017 REIMBURSEMENT
		1 433006742		\$33,589.71					
65884	MYTHICS INC	84785	06/16/2017	\$33,589.71		06/27/2017		Regular-PO	ORACLE DATABASE ENTERPRISE
		4 904006464		\$33,589.71					PACK 8 LICENSES TUNING PACK
		ADMINISTRATION							EDITION 4 LICENSES DIAGNOSTI
									8 LICENSES
		PJ 764 MAINTANANCE - ORACLE DATABASE; DIAG PACK; TUNING PACK		\$33,589.71	Received				
		001		1,000	Received	\$23,637.21			
		ORACLE DATABASE ENTERPRISE EDI		1,000	Received	\$4,976.25			
		DIAGNOSTIC PACK; 8 LICENSES		1,000	Received	\$4,976.25			
		002							
		TUNING PACK; 8 LICENSES							
		003							
		CAMP DRESSER & MCKEE INC.	05/27/2017	\$33,522.54		06/27/2017		Contract-PO	90019846
		32 522901B05009046413		\$33,522.54					SAVANNA ST WWTP STORM REHAB
		PUBLIC WORKS							
		CE 10 SAVANNA STR WWTP STORM CELL REHABILITATION PROJ. 1B0500902		\$2,064,210.00	Invoiced				
		001		315,000.000	Invoiced	\$315,000.00			
		TASK 1 - SAVANNA STR WWTP STOR		662,000.000	Invoiced	\$662,000.00			
		TASK ORDER NO. 2		1,087,210.000	Pt Invoiced	\$1,087,210.00			
		002							
		SAVANNA STR WWTP STORM CELL RE							
		003							
		GE INTELLIGENT PLATFORMS INC	05/08/2017	\$30,105.40		06/27/2017		R&R-Invoice	ANNUAL GLOBALCARE SUPPORT
		31 521356231		\$30,105.40					SOFTWARE MAINTENANCE
		PUBLIC WORKS							
		63701 MILLER MATERIALS INC	06/09/2017	\$30,076.18		06/27/2017		Regular-PO	LIMESTONE MATERIAL
		1 1502		\$30,076.18					
		Assets							
		PJ 1029 LIMESTONE STATE CONTRACT #8200026812		\$30,076.18					
		001 *C04801 (QUOTE/STATE CONTRACT) LIME S		996.560	Received	\$30,076.18			
		67443 COMPRESSED AIR TECH INC	03/29/2017	\$28,391.55		06/27/2017		R&R-Invoice	518100 518101 518102 518094
		31 521356514		\$28,391.55					AGENDA ITEM DATE MAY 16 2017
		PUBLIC WORKS							518095 518096 518097 518098
		72051 MICHAEL BAKER INTERNATI. INC.	06/01/2017	\$27,102.54		06/27/2017		Contract-PO	980090
		173 451356B45017016413		\$27,102.54					
		PUBLIC WORKS							
		CJ 14 MAYES ST BRIDGE REPLACEMENT		\$877,507.41					
		001		877,507.410	Pt Invoiced	\$877,507.41			
		MAYES ST BRIDGE REPLACEMENT							
		70889 JACKSON MEDICAL MALL FOUN	04/04/2017	\$27,093.00		06/27/2017		R&R-Invoice	SENIOR TRANSPORTATION FOR

AP755
 VENDOR PAYMENTS / FOR CLAIM DOCKET - 06/27/2017
 Report Title - AMOUNTS (DESCENDING) ALL TYPES
 Invoice Payments Over \$5,000

VEN#	VENDOR-NAME	INVOICE	INV-DATE	AMOUNT	AUTHORIZATION	DUE-DATE	REF-NUMBER	PAYMENT-TYPE	REMARKS
62983	MULTI-CON, INC	HUMAN & CULTURAL SERVICES	06/14/2017	\$27,093.00				R&R-Invoice	MARCH 2017
	85 845106485	COU4648N55		\$26,387.90					4648 NORTH STATE ST LIMITED
		PLANNING & DEVELOPMENT		\$26,387.90					REHABILITATION
64044	QUALITY COMMUNICATIONS INC	OC17-135	05/15/2017	\$25,450.00				Regular-PO	COST OF BUILDING ENTRY FOR
	302 443606847	ADMINISTRATION		\$15,010.00					BORING PER LINEAR FOOT FOR FS
	4 904006847	ADMINISTRATION		\$10,440.00					FS12 AERIAL RUN DIRECTIONAL
									16 COST OF SUPPLIES
PH	942 INSTALL FIBER RUNS @ FIRE STATIONS - TERM BID # 72523-0603			\$287,295.00					
001	(TERM BID) LINE 1- ITEM# 1- CO			1.000	Received	\$185.00			
002	LINE 2- ITEM #2 -COST OF AERIA			2,200.000	Received	\$4,400.00			
003	LINE 3- ITEM# 5 - COST OF LABE			12.000	Received	\$84.00			
004	LINE 4- ITEM# 6 - COST OF SPLI			6.000	Received	\$300.00			
005	LINE 5- ITEM# 7 - COST PER TER			6.000	Received	\$240.00			
006	LINE 6- ITEM# 1 - COST OF BULL			1.000	Received	\$185.00			
007	LINE 7- ITEM# 2 -COST OF AERIA			300.000	Received	\$600.00			
008	LINE 8- ITEM# 5 - COST OF LABE			12.000	Received	\$84.00			
009	LINE 9- ITEM# 6 - COST OF SPLI			6.000	Received	\$300.00			
010	LINE 10- ITEM# 7 - COST OF TER			6.000	Received	\$240.00			
011	LINE 11- ITEM#1 - COST OF BULL			1.000	Received	\$185.00			
012	LINE 12- ITEM# 2 - COST OF AER			2,800.000	Received	\$5,600.00			
013	LINE 13- ITEM# 5 - COST OF LAB			12.000	Approved	\$84.00			
014	LINE 14- ITEM# 6 - COST OF SPL			6.000	Approved	\$300.00			
015	LINE 15- ITEM# 7 - COST PER TE			6.000	Approved	\$240.00			
016	LINE 16- ITEM# 1- COST OF BULL			1.000	Received	\$185.00			
017	LINE 17- ITEM# 2 - COST OF AER			500.000	Received	\$1,000.00			
018	LINE 18- ITEM# 3 - COST OF LAB			12.000	Approved	\$84.00			
019	LINE 19- ITEM# 6 - COST PER SP			6.000	Approved	\$300.00			
020	LINE 20- ITEM# 7 - COST OF TER			6.000	Approved	\$240.00			
021	LINE 21- ITEM# 1 - COST OF BUI			1.000	Approved	\$185.00			
022	LINE 22- ITEM# 2 - COST OF AER			200.000	Approved	\$400.00			
023	LINE 23- ITEM# 5 - COST OF LAB			12.000	Approved	\$84.00			
024	LINE 24- ITEM# 6 - COST PER SP			6.000	Approved	\$300.00			
025	LINE 25- ITEM# 7- COST PER TER			6.000	Approved	\$240.00			
026	LINE 26- ITEM# 1 - COST PER BU			1.000	Received	\$185.00			
027	LINE 27- ITEM# 2 - COST OF AER			400.000	Received	\$800.00			
028	LINE 28- ITEM# 5 - COST OF LAB			12.000	Approved	\$84.00			
029	LINE 29- ITEM# 6 - COST PER SP			6.000	Approved	\$300.00			
030	LINE 30- ITEM# 7 - COST PER TE			6.000	Approved	\$240.00			
031	LINE 31- ITEM# 1 - COST OF BUI			1.000	Received	\$185.00			
032	LINE 32- ITEM# 2 - COST OF AER			6,400.000	Received	\$12,800.00			
033	LINE 33- ITEM# 3 - COST OF DIR			200.000	Received	\$2,700.00			
034	LINE 34- ITEM# 5 - COST OF LAB			12.000	Approved	\$84.00			

AP755
 Vendor PAYMENTS / FOR CLAIM DOCKET - 06/27/2017
 Report Title - AMOUNTS (DESCENDING) ALL TYPES
 Invoice Payments Over \$5,000

VEN#	VENDOR-NAME	INVOICE	INV-DATE	AMOUNT	AUTHORIZATION	DUE-DATE	REF-NUMBER	PAYMENT-TYPE	REMARKS
035		LINE 35- ITEM# 6 - COST PER SP		6,000	Approved	\$300.00			
036		LINE 36- ITEM# 7 - COST PER TE		6,000	Approved	\$240.00			
037		LINE 37- ITEM# 1 - COST OF BUI		1,000	Received	\$185.00			
038		LINE 38- ITEM# 2 - COST OF AER		2,000.000	Received	\$4,000.00			
039		LINE 39- ITEM# 5 - COST OF LAB		12,000	Received	\$84.00			
040		LINE 40- ITEM# 6 - COST PER SP		6,000	Received	\$300.00			
041		LINE 41- ITEM# 7 - COST PER TE		6,000	Received	\$240.00			
042		LINE 42- ITEM# 1 - COST OF BUI		1,000	Approved	\$185.00			
043		LINE 43- ITEM# 2 - COST OF AER		550,000	Approved	\$1,100.00			
044		LINE 44- ITEM# 3 - COST OF DIR		100,000	Received	\$1,350.00			
045		LINE 45- ITEM# 5 - COST OF LAB		12,000	Approved	\$84.00			
046		LINE 46- ITEM# 6 - COST PER SP		6,000	Approved	\$300.00			
047		LINE 47- ITEM# 7 - COST PER TE		6,000	Approved	\$240.00			
048		LINE 48- ITEM# 1 - COST OF BUI		1,000	Received	\$185.00			
049		LINE 49- ITEM# 2 - COST OF AER		250,000	Received	\$500.00			
050		LINE 50- ITEM# 3 - COST OF DIR		150,000	Pt received	\$2,025.00			
051		LINE 51- ITEM# 5 - COST OF LAB		12,000	Approved	\$84.00			
052		LINE 52- ITEM# 6 - COST PER SP		6,000	Approved	\$300.00			
053		LINE 53- ITEM# 7 - COST PER TE		6,000	Approved	\$240.00			
054		LINE 54- ITEM# 1 - COST OF BUI		1,000	Approved	\$185.00			
055		LINE 55- ITEM# 2 - COST OF AER		7,400,000	Approved	\$14,800.00			
056		LINE 56- ITEM# 5 - COST OF LAB		12,000	Approved	\$84.00			
057		LINE 57- ITEM# 6 - COST PER SP		6,000	Approved	\$300.00			
058		LINE 58- ITEM# 7 - COST PER TE		6,000	Approved	\$240.00			
059		LINE 59- ITEM# 1 - COST OF BUI		1,000	Received	\$185.00			
060		LINE 60- ITEM# 2 - COST OF AER		5,280,000	Received	\$10,560.00			
061		LINE 61- ITEM# 3 - COST OF DIR		150,000	Received	\$2,025.00			
062		LINE 62- ITEM# 5 - COST OF LAB		12,000	Approved	\$84.00			
063		LINE 63- ITEM# 6 - COST PER SP		6,000	Approved	\$300.00			
064		LINE 64- ITEM # 7 - COST PER T		6,000	Approved	\$240.00			
065		LINE 65- ITEM# 1 - COST OF BUI		1,000	Received	\$185.00			
066		LINE 66- ITEM# 2 - COST OF AER		260,000	Received	\$520.00			
067		LINE 67- ITEM# 3 - COST OF DIR		160,000	Received	\$2,160.00			
068		LINE 68- ITEM# 5 - COST OF LAB		12,000	Approved	\$84.00			
069		LINE 69- ITEM# 6 - COST PER SP		6,000	Approved	\$300.00			
070		LINE 70- ITEM# 7 - COST PER TE		6,000	Approved	\$240.00			
071		LINE 71- ITEM# 1 - COST OF BUI		1,000	Received	\$185.00			
072		LINE 72- ITEM# 2 - COST OF AER		11,616,000	Received	\$23,232.00			
073		LINE 73- ITEM# 5 - COST OF LAB		12,000	Approved	\$84.00			
074		LINE 74- ITEM# 6 - COST PER SP		6,000	Approved	\$300.00			
075		LINE75- ITEM# 7 - COST PER TER		6,000	Approved	\$240.00			
076		LINE 76- ITEM# 1 - COST OF BUI		1,000	Approved	\$185.00			

AP755
 VENDOR PAYMENTS / FOR CLAIM DOCKET - 06/27/2017
 Report Title - AMOUNTS (DESCENDING) ALL TYPES
 Invoice Payments Over \$5,000

VEN#	VENDOR-NAME	INVOICE	INV-DATE	AMOUNT	AUTHORIZATION	DUE-DATE	REF-NUMBER	PAYMENT-TYPE	REMARKS
077		LINE 77- ITEM# 2 - COST OF AER		300.000	Approved	\$600.00			
078		LINE 77- ITEM# 3 - COST OF DIR		200.000	Received	\$2,700.00			
079		LINE 79- ITEM# 5 - COST OF LAB		12.000	Approved	\$84.00			
080		LINE 80- ITEM# 6 - COST PER SP		6.000	Approved	\$300.00			
081		LINE 81- ITEM# 7 - COST PER TE		6.000	Approved	\$240.00			
082		LINE 82- ITEM# 1 - COST OF BU		1.000	Received	\$185.00			
083		LINE 83- ITEM# 2 - COST OF AER		270.000	Received	\$540.00			
084		LINE 84- ITEM# 3 - COST OF DIR		170.000	Received	\$2,295.00			
085		LINE 85- ITEM# 5 - COST OF LAB		12.000	Received	\$84.00			
086		LINE 86- ITEM# 6 - COST PER SP		6.000	Received	\$300.00			
087		LINE 87- ITEM# 7 - COST PER TE		6.000	Received	\$240.00			
088		LINE 88- ITEM# 1 - COST OF BU		1.000	Received	\$185.00			
089		LINE 89- ITEM# 1 - COST OF AER		300.000	Received	\$600.00			
090		LINE 90- ITEM# 3 - COST OF DIR		200.000	Received	\$2,700.00			
091		LINE 91- ITEM# 5 - COST OF LAB		12.000	Approved	\$84.00			
092		LINE 92- ITEM# 6 - COST PER SP		6.000	Approved	\$300.00			
093		LINE 93- ITEM# 7 - COST PER TE		6.000	Approved	\$240.00			
094		LINE 94- ITEM# 1 - COST OF BU		1.000	Received	\$185.00			
095		LINE 95- ITEM# 2 - COST OF AER		600.000	Received	\$1,200.00			
096		LINE 96- ITEM# 3 - COST OF DIR		500.000	Received	\$6,750.00			
097		LINE 97- ITEM# 5 - COST OF LAB		12.000	Received	\$84.00			
098		LINE 98- ITEM# 6 - COST PER SP		6.000	Received	\$300.00			
099		LINE 99- ITEM# 7 - COST PER TE		6.000	Received	\$240.00			
100		LINE 100- ITEM# 1 - BUILDING E		1.000	Approved	\$185.00			
101		LINE 101- ITEM# 2 - COST OF AE		2,112.000	Pt received	\$4,224.00			
102		LINE 102- ITEM# 3 - COST OF DI		100.000	Received	\$1,350.00			
103		LINE 103- ITEM# 5 - COST OF LA		12.000	Approved	\$84.00			
104		LINE 104- ITEM# 6 - COST PER S		6.000	Approved	\$300.00			
105		LINE 105- ITEM# 7 - COST PER T		6.000	Approved	\$240.00			
106		LINE 106- ITEM# 1 - COST OF BU		1.000	Approved	\$185.00			
107		LINE 107- ITEM# 2 - COST OF AE		1,800.000	Approved	\$3,600.00			
108		LINE 108- ITEM# 3 - COST OF DI		60.000	Received	\$810.00			
109		LINE 109- ITEM# 5 - COST OF LA		12.000	Approved	\$84.00			
110		LINE 110- ITEM# 6 - COST PER S		6.000	Approved	\$300.00			
111		LINE 111- ITEM# 7 - COST PER T		6.000	Approved	\$240.00			
112		LINE 112- ITEM# 1 - COST OF BU		1.000	Received	\$185.00			
113		LINE 113- ITEM# 2 - COST OF AE		2,000.000	Received	\$4,000.00			
114		LINE 114- ITEM# 5 - COST OF LA		12.000	Received	\$84.00			
115		LINE 115- ITEM# 6 - COST PER S		6.000	Received	\$300.00			
116		LINE 116- ITEM# 7 - COST PER T		6.000	Received	\$240.00			
117		LINE 117- ITEM# 14 - COST OF S		157.000	Received	\$7,065.00			
118		LINE 118- ITEM# 14 - COST OF S		157.000	Received	\$7,065.00			

AP755 VENDOR PAYMENTS / FOR CLAIM DOCKET - 06/27/2017
 Report Title - AMOUNTS (DESCENDING) ALL TYPES
 Invoice Payments Over \$5,000

VEN#	VENDOR-NAME	INVOICE	INV-DATE	AMOUNT	AUTHORIZATION	DUE-DATE	REF-NUMBER	PAYMENT-TYPE	REMARKS
119		LINE 119- ITEM# 14 - COST OF S		157,000	Received	\$7,065.00			
120		LINE 120- ITEM# 14 - COST OF S		157,000	Received	\$7,065.00			
121		LINE 121- ITEM# 14 - COST OF S		157,000	Received	\$7,065.00			
122		LINE 122- ITEM# 14 - COST OF S		157,000	Received	\$7,065.00			
123		LINE 123- ITEM# 14 - COST OF S		157,000	Received	\$7,065.00			
124		LINE 124- ITEM# 14 - COST OF S		157,000	Received	\$7,065.00			
125		LINE 125- ITEM# 14 - COST OF S		157,000	Approved	\$7,065.00			
126		LINE 126- ITEM# 14 - COST OF S		157,000	Received	\$7,065.00			
127		LINE 127- ITEM# 14 - COST OF S		157,000	Approved	\$7,065.00			
128		LINE 128- ITEM# 14 - COST OF S		157,000	Received	\$7,065.00			
129		LINE 129- ITEM# 14 - COST OF S		157,000	Received	\$7,065.00			
130		LINE 130- ITEM# 14 - COST OF S		157,000	Received	\$7,065.00			
131		LINE 131- ITEM# 14 - COST OF S		157,000	Received	\$7,065.00			
132		LINE 132- ITEM# 14 - COST OF S		157,000	Pt received	\$7,065.00			
133		LINE 133- ITEM# 14 - COST OF S		157,000	Received	\$7,065.00			
134		LINE 134- ITEM# 14 - COST OF S		157,000	Received	\$7,065.00			
135		LINE 135- ITEM# 14 - COST OF S		157,000	Received	\$7,065.00			
136		LINE 136- ITEM# 14 - COST OF S		157,000	Received	\$7,065.00			
137		LINE 137- ITEM# 14 - COST OF S		157,000	Received	\$7,065.00			
71951	TRILOGY ENGINEERING SERV LLC	2017-009	06/06/2017	\$22,572.00		06/27/2017		Contract-PO	2017-009 WATER TREATMENT SYSTEM CORROSI ON CONTROL STUDY
		32 521906B01039016485		\$22,572.00					
		PUBLIC WORKS							
CI	31 MS STATE DEPT OF HEALTH COMPLIANCE PLAN			\$291,699.00					
		001		291,699.00	Pt Invoiced	\$291,699.00			
69009	VECTOR DISEASE CONTROL INC.	PI-A00001992	05/31/2017	\$20,289.99		06/27/2017		R&R-Invoice	PI-A00001992 MONTHLY PEST SERVICES
		1 431006419		\$20,289.99					
72052	STUART CONSULTING GROUP, INC.	10465	05/29/2017	\$19,993.00		06/27/2017		Contract-PO	10465 TOWN CREEK TRIBUTARY #4
		173 451355B50063016413		\$19,993.00					
		PUBLIC WORKS							
CJ	13 WOODROW WILSON AVE TO ERIE ST			\$146,000.00					
		001		146,000.00	Pt Invoiced	\$146,000.00			
71414	UTILITREC	295768	05/31/2017	\$19,893.72		06/27/2017		R&R-Invoice	MAY 2017 POSTAGE USAGE
		31 520106421		\$19,893.72					
71931	VOLKERT INC	00205008	06/01/2017	\$18,022.34		06/27/2017		Contract-PO	00205008 ROBINSON ROAD BRIDGE
		173 451355B45034026413		\$18,022.34					
		PUBLIC WORKS							
CJ	42 ROBINSON ROAD BRIDGE/OVER CANY CREEK			\$149,980.97					
		001		149,980.97	Pt Invoiced	\$149,980.97			
70176	STANTEC CONSULTING SERVICES	1202425	05/26/2017	\$17,582.09		06/27/2017		Contract-PO	1202425 WEST ST BRIDGE REHAB
		173 451357B45007016413		\$17,582.09					
		PUBLIC WORKS							
CJ	20 WEST ST BRIDGE REHAB PROJECT			\$109,600.00					
		001		109,600.00	Pt Invoiced	\$109,600.00			
70705	ELECTION SYSTEMS & SOFTWARE	1010735	06/02/2017	\$17,334.00		06/27/2017		R&R-Invoice	2017 MUN PRIMARY RUN-OFF ELECTION 05/16/17
		1 402206419		\$17,334.00					
		GENERAL GOVERNMENT							

AP755 VENDOR PAYMENTS / FOR CLAIM DOCKET - 06/27/2017
 Report Title - AMOUNTS (DESCENDING) ALL TYPES
 Invoice Payments Over \$5,000

VEN#	VENDOR-NAME	INVOICE	INV-DATE	AMOUNT	AUTHORIZATION	DUE-DATE	REF-NUMBER	PAYMENT-TYPE	REMARKS
19388	HATHORN'S PEST CONTROL INC	01-0305067	05/28/2017	\$17,271.43		06/27/2017		R&R-Invoice	01-0305067
	1 431006419	PUBLIC WORKS		\$17,271.43					MONTHLY PEST SERVICE
68672	CLARK AUCTIONS	060917	06/09/2017	\$16,343.32		06/27/2017		R&R-Invoice	AUCTION FEE FOR JUNE 03, 2017
	2 907006419	PUBLIC SAFETY - POLICE		\$16,343.32					
69650	COLEMAN NICHOLAS	061917	06/19/2017	\$15,000.00		06/27/2017		R&R-Invoice	JULY 2017 INDIGENT LEGAL
	1 407706414	GENERAL GOVERNMENT		\$15,000.00					DEFENDANTS PROFESSIONAL SERVICE
70128	CMR	06201707	06/07/2017	\$15,000.00		06/27/2017		R&R-Invoice	MANAGEMENT AND OPERATION
	5 501406419	PARKS & RECREATION		\$15,000.00					SERVICES JUNE 2017 PAYMENT
71365	ALLEN ENGINE & SCIENCE INC	00170438	05/28/2017	\$14,926.11		06/27/2017		Contract-PO	00170438
	173 451355B50159016419	PUBLIC WORKS		\$14,926.11					STORMWATER MANAGEMENT SERVICES
	CJ 18 STORMWATER MANAGEMENT	PROFESSIONAL ENGINEERING SERVICES		\$374,000.00					
	001	STORMWATER MANAGEMENT PROFESSI		374,000.000	Pt Invoicd	\$374,000.00		R&R-Invoice	BILL BACK ITEMS
71755	NATIONAL EXPRESS TRANSIT CORP	91440985	05/10/2017	\$14,557.19		06/27/2017		R&R-Invoice	
	187 565106215	PLANNING & DEVELOPMENT		\$2,557.19					ALEXANDER LIBRARY AT 2425
	187 565106425	PLANNING & DEVELOPMENT		\$12,000.00					SPACE FOR MARGARET WALKER
63385	BLOUNT RICHARD MD	5011	06/01/2017	\$12,950.00		06/27/2017		R&R-Invoice	PAYMENT FOR JULY 2017 RENTAL
	1 2381	Liabilities		\$9,453.50					ROBINSON ROAD
	1 412106512	ADMINISTRATION		\$3,496.50					ROBINSON ROAD
63385	BLOUNT RICHARD MD	5012	06/15/2017	\$12,950.00		06/27/2017		R&R-Invoice	PAYMENT FOR JULY 2017 RENTAL
	1 2381	Liabilities		\$9,453.50					ALEXANDER LIBRARY AT 2425
	1 412106512	ADMINISTRATION		\$3,496.50					SPACE FOR MARGARET WALKER
71931	VOLKERT INC	00905013	06/01/2017	\$12,846.18		06/27/2017		Contract-PO	00905013
	173 451355B45034026413	PUBLIC WORKS		\$12,846.18					ROBINSON ROAD BRIDGE
	CJ 42 ROBINSON ROAD BRIDGE/OVER CANY CREEK			\$149,980.97					
	001	ROBINSON ROAD BRIDGE/OVER CANY		149,980.970	Pt Invoicd	\$149,980.97		R&R-Invoice	
70705	ELECTION SYSTEMS & SOFTWARE	1010609	06/02/2017	\$12,665.75		06/27/2017		R&R-Invoice	2017 MUNICIPAL GENERAL ELECTIO
	1 402206419	GENERAL GOVERNMENT		\$12,665.75					BALLOTS AND CODING BALLOTS
61991	SANSOM EQUIPMENT CO., INC.	49913	12/22/2016	\$12,593.52		06/27/2017		Regular-PO	(JUNE 6 2017)ELECTION DAY
	31 522206316	PUBLIC WORKS		\$12,593.52					LABOR SHOP SUPPLIES AIR
									CYLINDER HYD TIE ROD ROLLER
									CYLINDER BLOCK STOP TOOTH
									FRAME WELD CYLINDER MOUNTING P
PJ	347 TK-717 Repairs	(Quote) Shop Supplies		\$12,593.52					
	001	45551-30 Air Cylinder 1.0625"x		1,000	Received	\$125.00			
	002	61297D-30 Block Stop Tooth		2,000	Received	\$116.04			
	003	46961-30 Cylinder, Hyd, Tie Ro		2,000	Received	\$177.58			
	004	81925F-30 Roller Frame Weld		1,000	Received	\$381.33			
	005	81936D-30 Cylinder Mounting Pl		1,000	Received	\$407.66			
	006	29662-30 Seal, Sensing Rod		2,000	Received	\$81.55			
	007			2,000	Received	\$10.04			

AP755
 VENDOR PAYMENTS / FOR CLAIM DOCKET - 06/27/2017
 Report Title - AMOUNTS (DESCENDING) ALL TYPES
 Invoice Payments Over \$5,000

VEN#	VENDOR-NAME	INVOICE	INV-DATE	AMOUNT	AUTHORIZATION	DUE-DATE	REF-NUMBER	PAYMENT-TYPE	REMARKS
008		46833A-30 Valve, Hyd, Directio		1,000	Received	\$1,784.75			
009		82804-30 Arrowboard Mod		1,000	Received	\$1,075.43			
010		70499-30 Light-Aux, Light Clea		2,000	Received	\$143.69			
011		69335A-30 Footage Counter Assy		1,000	Received	\$751.34			
012		40019-30 Valve-Gate 3" Screw T		1,000	Received	\$266.04			
013		45548H-30 Bearing Hardened Rac		1,000	Received	\$1,649.00			
014		47773C-30 Ignition/Start Switc		1,000	Received	\$92.82			
015		45803-30 Screen 2" STNLS		1,000	Received	\$25.40			
016		46137-30 Cage Gasket / For 2"		1,000	Received	\$6.37			
017		46138-30 Cap Gasket / 2" Y-Str		1,000	Received	\$9.77			
018		41280-30 Screen, 80 Mesh, 3		1,000	Received	\$28.12			
019		41271-30 Cap Gasket / For 3" Y		1,000	Received	\$4.27			
020		41272-30 Cage Gasket / For 3"		1,000	Received	\$5.40			
021		Misc. Lights Hydraulic Hose, E		1,000	Received	\$150.00			
022		Hydraulic Oil		70,000	Received	\$638.40			
023		1099061 Cartridge-Hyd Filter		1,000	Received	\$128.26			
024		Oil Blower Oil		3,000	Received	\$54.48			
025		Oil Transfer Case Oil		5,000	Received	\$60.35			
026		48051AF-30 Filter, Oil (48051,		1,000	Received	\$139.51			
027		48783S6-30 Rodder Line, 1x600F		1,000	Received	\$1,620.92			
028		LABOR		1,000	Received	\$2,660.00			
47216	EASTENAL COMPANY	MSJACT3656	05/25/2017	\$11,650.00		06/27/2017		Regular-PO	LATEX GLOVES
1	1502	Assets		\$11,650.00					
				\$11,650.00					
61728	HUNTER SAND & GRAVEL INC			\$11,620.16		06/27/2017		Regular-PO	WHITE SAND
1	1502	Assets	06/16/2017	\$11,620.16					
				\$11,620.16					
		QUOTE--LATEX GLOVES		1,000,000	Received	\$11,650.00			
		001 *C04326							
		0111	06/16/2017	\$11,620.16		06/27/2017		Regular-PO	WHITE SAND
		Assets		\$11,620.16					
				\$11,620.16					
		QUOTE---WHITE RIVER SAND		1,028,320	Received	\$11,620.02			
		001 *C04189							
		QC17-141	06/14/2017	\$11,430.00		06/27/2017		Regular-PO	DSX MAINTENANCE CONTROLLER
		ADMINISTRATION		\$11,430.00					CARDS READERS DSX CARD ACCESS
				\$11,430.00					
64044	QUALITY COMMUNICATIONS INC			\$70,995.00					
4	904006464	YEARLY MAINTENANCE - DSX CARD ACCESS SYSTEMS -		1,000	Approved	\$1,575.00			
PJ	925 MAINTENANCE - DSX CARD ACCESS SYSTEMS -			1,000	Approved	\$125.00			
001		YEARLY MAINTENANCE FOR CITY HA		1,000	Approved	\$490.00			
002		PANIC BUTTONS - ITEM# 55		1,000	Approved	\$1,440.00			
003		REPEATERS - ITEM# 56		1,000	Approved	\$2,760.00			
004		INSTALLATION / HOURLY - ITEM#		0,120	Approved	\$2,180.00			
005		YEARLY MAINTENANCE FOR CITY HA		2,000	Received	\$570.00			
006		CONTROLLER CARDS - ITEM# 59		2,000	Approved	\$360.00			
007		ELECTRONIC STRIKE - INCLUDES M		2,000	Received	\$2,880.00			
008		READERS - ITEM# 62		24,000	Approved	\$315.00			
009		INSTALLATION / LABOR - DSX SYS		3,000	Approved				
010		CAMERA MAINTENANCE - INCLUDES			Approved				

AP755

VENDOR PAYMENTS / FOR CLAIM DOCKET - 06/27/2017
 Report Title - AMOUNTS (DESCENDING) ALL TYPES
 Invoice Payments Over \$5,000

VEN#	VENDOR-NAME	INVOICE	INV-DATE	AMOUNT	AUTHORIZATION	DUE-DATE	REF-NUMBER	PAYMENT-TYPE	REMARKS
011		CAMERA MAINTENANCE - INCLUDES		2.000	Approved	\$1,500.00			
012		INSTALLATION / LABOR (CAMERA S		24.000	Approved	\$2,880.00			
013		YEARLY MAINTENANCE FOR HOOD BU		0.070	Approved	\$1,610.00			
014		CONTROLLER CARDS - ITEM# 59		2.000	Received	\$2,180.00			
015		ELECTRONIC STRIKE - INCLUDES M		2.000	Approved	\$570.00			
016		READERS - ITEM# 62		2.000	Received	\$360.00			
017		INSTALLATION / LABOR - DSX SYS		24.000	Approved	\$2,880.00			
018		CAMERA MAINTENANCE - INCLUDES		4.000	Approved	\$420.00			
019		CAMERA MAINTENANCE - INCLUDES		2.000	Approved	\$1,500.00			
020		INSTALLATION / LABOR (CAMERA S		24.000	Approved	\$2,880.00			
021		YEARLY MAINTENANCE FOR CITY OF		0.090	Approved	\$2,070.00			
022		DSX CARD ACCESS - ITEM# 59		2.000	Received	\$2,180.00			
023		ELECTRONIC STRIKE - INCLUDEDS		2.000	Approved	\$570.00			
024		READERS - ITEM# 62		2.000	Received	\$360.00			
025		INSTALLATION / LABOR - DSX SYS		24.000	Approved	\$2,880.00			
026		CAMERA MAINTENANCE - INCLUDES		3.000	Approved	\$315.00			
027		CAMERA MAINTENANCE - INCLUDES		1.000	Approved	\$750.00			
028		INSTALLATION / LABOR (CAMERA S		24.000	Approved	\$2,880.00			
029		YEARLY MAINTENANCE FOR CITY OF		0.060	Approved	\$1,380.00			
030		CONTROLLER CARDS - ITEM# 59		1.000	Received	\$1,090.00			
031		ELECTRONIC STRIKE - INCLUDES M		1.000	Approved	\$285.00			
032		READERS - ITEM# 62		1.000	Received	\$180.00			
033		INSTALLATION / LABOR DSX SYSTE		12.000	Approved	\$1,440.00			
034		YEARLY MAINTENANCE FOR CITY OF		0.320	Approved	\$7,360.00			
035		CONTROLLER CARDS - ITEM# 59		2.000	Received	\$2,180.00			
036		ELECTRONIC STRIKE - INCLUDES M		2.000	Approved	\$570.00			
037		READERS - ITEM# 62		2.000	Received	\$360.00			
038		INSTALLATION / LABOR - DSX SYS		24.000	Approved	\$2,880.00			
039		CAMERA MAINTENANCE - INCLUDES		6.000	Approved	\$630.00			
040		CAMERA MAINTENANCE - INCLUDES		2.000	Approved	\$1,500.00			
041		INSTALLATION / LABOR (CAMERA &		24.000	Approved	\$2,880.00			
042		YEARLY MAINTENANCE SURVEILLANC		30.000	Approved	\$3,150.00			
043		SURVEILLANCE CAMERA MAINTENANC		1.000	Approved	\$750.00			
044		INSTALLATION / HOURLY - ITEM#		24.000	Approved	\$2,880.00			
20377	ENERGERY	18625301\	06/27/2017	\$10,716.62			186760	UTILITY-PAYM	
		PUBLIC WORKS		\$10,716.62					
		1 453006451							
		PUBLIC WORKS							
		0+18625301	06/19/2017	\$10,546.75			0.1	\$10,716.62	ELECTRIC LIGHT AND POWER
		1 453006451							
		PUBLIC WORKS							
		43122 WASTE MANAGEMENT OF MS INC	06/27/2017	\$10,546.75				R&R-Invoice	DISPOSAL CONTRAL
		9 455106426							PORTLAND 92.6# ASH GROVE TYPE
		PUBLIC WORKS							PORTLAND 92.6#ASH GROVE TYPE
		47070 PRECISION PACKAGING INC.	05/17/2017	\$8,981.00				Regular-PO	I/II PALLET
		1 1502							
		Assets							
		JAX92246							
		1 1502							

AP755 VENDOR PAYMENTS / FOR CLAIM DOCKET - 06/27/2017
 Report Title - AMOUNTS (DESCENDING) ALL TYPES
 Invoice Payments Over \$5,000

VEN#	VENDOR-NAME	INVOICE	INV-DATE	AMOUNT	AUTHORIZATION	DUE-DATE	REF-NUMBER	PAYMENT-TYPE	REMARKS
PJ	1027 PORTLAND CEMENT	TERM BID#75021-102114		\$8,981.00					
	001 *C02383	(TERM BID) CEMENT, PORTLAND		980.000	Received	\$8,771.00			
	002	PALLET CHARGE		14.000	Received	\$210.00			
16061	JACKSON COMMUNICATIONS CO	S18105	05/16/2017	\$8,415.00		06/27/2017		Regular-PO	IMPRESS 2 LIION BATT
	302 443606226	ADMINISTRATION		\$8,415.00					
PJ	1022 BACK UP BATTERIES FOR JPD AND JFD			\$8,415.00					
	001	Q--ITEM# PMNN4486 BATT IMPRES		25.000	Received	\$3,017.50			
	002	ITEM# PMNN4485A IMPRES 2 LIION		50.000	Received	\$5,397.50			
63387	FREEMAN WATER TREATMENT	10186	05/12/2017	\$7,975.00		06/27/2017		Regular-PO	WATER SOFTENER
	31 521356461	PUBLIC WORKS		\$7,975.00					
PJ	974 NEW WATER SOFTENER EQUIPMENT FROM AMMONIA INJECTORS			\$7,975.00					
	001	(QUOTE) TWIN ALTERNATING WAT		1.000	Received	\$6,568.77			
	002	LABOR, MATERIAL AND FREIGHT		1.000	Received	\$1,406.23			
71414	UTILITEC	295767	05/31/2017	\$7,760.82		06/27/2017		R&R-Invoice	BASE STATEMENT PROCESSING
	31 520106421	PUBLIC WORKS		\$7,760.82					
30736	APAC MISS INC	4000066997	12/24/2016	\$6,234.30		06/27/2017		R&R-Invoice	4000066997 COLD MIX
	1 451246320	PUBLIC WORKS		\$6,234.30					
71192	PYROFIRE DISPLAYS	JACK7-1D	06/09/2017	\$6,000.00		06/27/2017		R&R-Invoice	OUTDOOR PYROTECNICS DISPLAY
	5 501106419	PARKS & RECREATION		\$6,000.00					
30736	APAC MISS INC	4000068428	03/18/2017	\$5,899.17		06/27/2017		R&R-Invoice	4000068428 COLD MIX
	1 451246320	PUBLIC WORKS		\$5,899.17					
20377	ENTERGY	18258350\	06/27/2017	\$5,854.60		06/27/2017	18258616	R&R-Invoice	UTILITY-PAYM
	31 521306451	PUBLIC WORKS		\$5,854.60					
41410	TRUSTMARK NATIONAL BANK	26868	06/19/2017	\$5,750.00		06/19/2017	0.1	\$5,854.60	ELECTRIC LIGHT AND POWER
	220 577806614	PUBLIC WORKS		\$2,817.00		06/27/2017		R&R-Invoice	W/S BOND SERIES 2013 PAYING
	220 577856614	PUBLIC WORKS		\$2,933.00					AGENT FEE
71554	W T CONSULTANTS	06012017	06/01/2017	\$5,600.00		06/27/2017		R&R-Invoice	STATE LOBBYIST FOR JUNE 2017
	1 407806419	GENERAL GOVERNMENT		\$5,600.00					MONTH OF JUNE
69220	FLANNIGAN ELECTRIC CO INC	364855	05/18/2017	\$5,553.25		06/27/2017		Regular-PO	FOR SERVICES RENDERED FOR THE
	31 521306317	PUBLIC WORKS		\$5,553.25					MOTOR
PJ	1024 SIWELL ROAD WELLS MOTOR REPAIR - J. H. FEWELL WTP			\$5,553.25					
	001	(QUOTE) MATERIAL COST - MOTOR		1.000	Received	\$1,153.25			
	002	LABOR COST - TO REPAIR MOTOR		1.000	Received	\$4,400.00			
71755	NATIONAL EXPRESS TRANSIT CORP	91420164	06/10/2017	\$5,336.80		06/27/2017		R&R-Invoice	BILL BACK ITEMS
	187 565106425	PLANNING & DEVELOPMENT		\$5,336.80					
59392	BFI WASTE SYSTEMS OF MS LLC	5101000032649	05/15/2017	\$5,166.75		06/27/2017		R&R-Invoice	LANDFILL SERVICES FOR SLUDGE
	31 521356497	PUBLIC WORKS		\$5,166.75					
71264	YAMAHA MOTOR CORPORATION U S A	608345	05/27/2017	\$5,054.10		06/27/2017		R&R-Invoice	GOLF RENTAL
	5 504306514	PARKS & RECREATION		\$5,054.10					

AP755

VENDOR PAYMENTS / FOR CLAIM DOCKET - 06/27/2017
Report Title - AMOUNTS (DESCENDING) ALL TYPES
Invoice Payments Over \$5,000

VEN#	VENDOR-NAME	INVOICE	INV-DATE	AMOUNT	AUTHORIZATION	DUE-DATE	REF-NUMBER	PAYMENT-TYPE	REMARKS
*** Payments Over \$5,000 Total ***									
=====									
				\$3,107,116.33					

AP755 VENDOR PAYMENTS / FOR CLAIM DOCKET - 06/27/2017
 Report Title - AMOUNTS (DESCENDING) ALL TYPES
 Invoice Payments Under \$5,000 - Over \$500

VEN#	VENDOR-NAME	INVOICE	INV-DATE	AMOUNT	AUTHORIZATION	DUE-DATE	REF-NUMBER	PAYMENT-TYPE	REMARKS
67383	CROWN ENGINEERING PLLC	CE016261-4	06/06/2017	\$5,000.00		06/27/2017		Contract-PO	CE016261-4
	156 451906B50029016413	PUBLIC WORKS		\$5,000.00					NRCS EWP DRAINAGE
61991	CI 41 NRCS EWP DRAINAGE IMPROVEMENT, 16B5002.901	NRCS EWP DRAINAGE IMPROVEMENT,	05/17/2017	\$60,000.00	Pt Invoicd	06/27/2017		Limited-PO	LABOR WIRING HARNESS 2100 SER
	001	51157		\$4,997.02					FREIGHT
	31 522206316	PUBLIC WORKS		\$4,997.02					
	LJ 1446 TK 717 REPAIR WIRING HARNESS,	TK 717 REPAIR WIRING HARNESS		\$4,997.02	Received	06/27/2017		R&R-Invoice	WRECKER SERVICES 56380 56388
46223	STREET ENTERPRISES	55876/56011	05/30/2017	\$4,970.00		06/27/2017		R&R-Invoice	56462 56473 56422 56428 56479
	1 442206465	PUBLIC SAFETY - POLICE		\$4,970.00				Regular-PO	TISSUE AND PAPER TOWELS
09200	JACKSON PAPER CO	737655	04/20/2017	\$4,940.70		06/27/2017		Regular-PO	
	1 457006213	PUBLIC WORKS		\$4,940.70					
	PJ 873 Custodial Supplies	QUOTE---2-ply bath tissue		\$4,940.75	Received	06/27/2017			JCL LAMP QLL0186-001 FOR KWP
	001	singlefold paper towels		100.00	Received	\$2,912.00			SMG2 PROJECTOR SHIPPING
	002	multifold paper towels		75.00	Received	\$1,016.25			
	003			75.00	Received	\$1,012.50			
71139	MAGNA-TECH ELECTRONIC CO INC	B1751	05/22/2017	\$4,800.00		06/27/2017		Regular-PO	
	1 408106315	HUMAN & CULTURAL SERVICES		\$4,800.00					
	PJ 1039 LAMP FOR PROJECTOR	Q--JVC LAMP FOR SMG2 PROJECTOR		\$4,800.00	Received	\$4,800.00		R&R-Invoice	CROWLEY LEANDER(16J-160WC) 00
	001			1.000					
54148	CAPITAL ORTHOPAEDIC CLINIC	000100239559	04/20/2017	\$4,755.73		06/27/2017		R&R-Invoice	1202423
	1 407926481	GENERAL GOVERNMENT		\$4,755.73				Contract-PO	EUBANKS CREEK DRAINAGE
70176	STANTEC CONSULTING SERVICES	1202423	05/26/2017	\$4,539.08		06/27/2017			
	173 451356B50007016413	PUBLIC WORKS		\$4,539.08					
	CI 46 EUBANKS CREEK DRAINAGE IMPROVEMENT	EUBANKS CREEK DRAINAGE IMPROVE		\$387,000.00	Pt Invoicd	\$387,000.00		R&R-Invoice	CROWLEY LEANDER(16J-160WC) 00
	001			387,000.00					042617
54148	CAPITAL ORTHOPAEDIC CLINIC	000100239560	04/26/2017	\$4,419.18		06/27/2017		R&R-Invoice	
	1 407926481	GENERAL GOVERNMENT		\$4,419.18					
20377	ENERGY	18258046\	06/27/2017	\$4,320.79		06/27/2017	18258350	UTILITY-PAYM	
	31 521306451	PUBLIC WORKS		\$4,320.79					
	0+18258046	PUBLIC WORKS		\$4,320.79					
32063	MS DEVELOPMENT AUTHORITY	50235 06012017	06/01/2017	\$4,276.17		06/27/2017	0.1	R&R-Invoice	ELECTRIC LIGHT AND POWER
	10 509006619	FIRE DEPARTMENT		\$4,276.17				R&R-Invoice	RE: GMS: 50235-LOAN FOR FIRE
									PAID FROM FIRE PROTECTION FUND
									STATION 28 THROUGH MDA AND
72623	FRIENDS OF THE MS ART GALLERY	617	06/08/2017	\$4,276.00		06/27/2017		R&R-Invoice	JUNE 2017 PAYMENT
	1 436206299	HUMAN & CULTURAL SERVICES		\$4,276.00					REIMBURSEMENT FOR MANNEQUINS
									EXHIBIT
19685	THYSSENKRUPP ELEVATOR	3003174402	05/01/2017	\$4,215.00		06/27/2017		R&R-Invoice	PURCHASED FOR WOOLMORTH 1963
	1 419106464	HUMAN & CULTURAL SERVICES		\$1,300.00					3033174402
	1 441706464	FIRE DEPARTMENT		\$135.00					MAY MONTHLY ELEVATOR SERVICE
	1 442356464	PUBLIC SAFETY - POLICE		\$130.00					

AP755
 VENDOR PAYMENTS / FOR CLAIM DOCKET - 06/27/2017
 Report Title - AMOUNTS (DESCENDING) ALL TYPES
 Invoice Payments Under \$5,000 - Over \$500

VEN#	VENDOR-NAME	INVOICE	INV-DATE	AMOUNT	AUTHORIZATION	DUE-DATE	REF-NUMBER	PAYMENT-TYPE	REMARKS
47046	HAYLES TOWING & RECOVERY SERVI	203373	04/25/2017	\$4,205.00		06/27/2017		Limited-PO	WRECKER SERVICES
31	521406465	PUBLIC WORKS		\$725.00	Received	\$300.00			
9	506106465	PUBLIC WORKS		\$370.00	Received	\$200.00			
1	451246465	PUBLIC WORKS		\$200.00	Received	\$45.00			
1	442406465	PUBLIC SAFETY - POLICE		\$135.00	Received	\$225.00			
31	522206465	PUBLIC WORKS		\$2,375.00	Received	\$200.00			
1	448806465	PUBLIC WORKS		\$200.00	Received	\$450.00			
1	451256465	PUBLIC WORKS		\$200.00	Received	\$200.00			
LJ	1798 PAYING VARIOUS TOWING	TICKETS		\$4,205.00	Received	\$300.00			
001	203373	TK 633		1,000	Received	\$200.00			
002	INVOICE 203038	TK 778		1,000	Received	\$200.00			
003	INVOICE 203037	TK 736		1,000	Received	\$200.00			
004	INVOICE 203985	PC 1556		1,000	Received	\$45.00			
005	INVOICE 203862	TK 775		1,000	Received	\$450.00			
006	INVOICE 203545	T 184		1,000	Received	\$225.00			
007	INVOICE 203433	TK 614		1,000	Received	\$200.00			
008	INVOICE 203580	T 199		1,000	Received	\$225.00			
009	INVOICE 202994	TK 774		1,000	Received	\$450.00			
010	INVOICE 203100	TK 775		1,000	Received	\$200.00			
011	INVOICE 202049	F 13		1,000	Received	\$85.00			
012	INVOICE 203666	F 13		1,000	Received	\$85.00			
013	INCOIE 203090	TK 634		1,000	Received	\$200.00			
014	INVOICE 203724	PC 1444		1,000	Received	\$45.00			
015	INVOICE 203340	TK 598		1,000	Received	\$200.00			
016	INVOICE 203074	TK 480		1,000	Received	\$200.00			
017	INVOICE 203073	TK 556		1,000	Received	\$200.00			
018	INVOICE 203067	TK 564		1,000	Received	\$200.00			
019	INVOICE 203193	PC 1836		1,000	Received	\$45.00			
020	INVOICE 203870	TK 774		1,000	Received	\$450.00			
70362	BAN PROPERTIES LLC	040617	04/06/2017	\$4,000.00		06/27/2017		Regular-PO	DEMO 30 FEET WALL & REPAIR
1	436206313	HUMAN & CULTURAL SERVICES		\$2,000.00	Received				
1	436206419	HUMAN & CULTURAL SERVICES		\$2,000.00	Received				CEILING
PJ	845 DEMO 30 FEET WALL AND	REPAIR CEILING		\$4,000.00	Received				
001	DEMO 30 FEET WALL AND REPAIR	C		1,000	Received	\$2,000.00			

AP755
 VENDOR PAYMENTS / FOR CLAIM DOCKET - 06/27/2017
 Report Title - AMOUNTS (DESCENDING) ALL TYPES
 Invoice Payments Under \$5,000 - Over \$500

VEN#	VENDOR-NAME	INVOICE	INV-DATE	AMOUNT	AUTHORIZATION	DUE-DATE	REF-NUMBER	PAYMENT-TYPE	REMARKS
70326	RETRO METRO LLC	LABOR		1,000	Received	\$2,000.00			
		002							
		06152017	06/15/2017	\$3,950.00	Received	06/27/2017		R&R-Invoice	JULY 2017 SUPPLEMENTAL LEASE PAYMENT FOR METROCENTER MALL
		31 520106512		\$1,446.10					
		1 442426512		\$387.58					
		300 443466512		\$671.77					
		5 501106512		\$279.53					
		1 413006512		\$374.80					
		1 433006512		\$790.22					
11058	MID-SOUTH UNIFORM & SUPPLY	HUMAN & CULTURAL SERVICES		\$3,874.25		06/27/2017		Regular-PO	BADGES COLLAR BRASS
		562891	05/31/2017	\$3,874.25					
		2 907006217		\$3,874.25					NAMEPLATES
		001		\$3,874.25					
		002		75.000	Received	\$1,199.25			
		003		150.000	Received	\$1,230.00			
		BC-1332-HIGL BADGE-BLUE BORDER		17.000	Received	\$1,445.00			
72166	PONDEROSA FENCE & GATE	HUMAN & CULTURAL SERVICES		\$3,818.00		06/27/2017		Regular-PO	PROVIDE AND INSTALL SLIDE GATE TOR MULTICODE RADIO RECEIVER DOORKING 9024 SLIDE GATE OPERA WITH 5 TRANSMITTERS WIRLESS
		5438	06/05/2017	\$3,818.00					
		1 436006317		\$3,818.00					
		001		\$3,818.00	Received	\$3,818.00		Limited-PO	REAR BUMPER COVER LAMP ASSY
		001		1,000	Received	06/27/2017			QUARTER PANEL REAR BODY PANEL BUMPER INPUT ABSORBER RIGHT PILLAR PARTS LABOR
		(QUOTE) PROVIDE AND INSTALL SL		\$3,771.32					
		695595	06/01/2017	\$3,771.32					
		1 442406316		\$3,771.32					
		001		\$3,771.32	Received	\$3,771.32		Regular-PO	WATERSTOP 50# QUIKRETE PALLET SHRINK WRAP PALLET
		001		1,000	Received	06/27/2017			
		INVOICE 695595 REPAIR OF PC 17		\$3,735.52					
		JAX92522	06/07/2017	\$3,735.52					
		1 1502		\$3,735.52					
		Assets		\$3,795.52					
		001 *C04879		108.000	Received	\$3,719.52			
		002		4.000	Cancelled	\$60.00			
		003		4.000	Received	\$16.00			
		QUOTE--WATERSTOP CEMENT 50#		\$3,733.33		03/22/2017		R&R-Invoice	MUNICIPAL GARAGE
		SHRINK WRAP		\$3,333.33					
		JACO0037018702	03/22/2017	\$3,333.33					
		001		\$400.00					
		002		\$3,600.00		06/27/2017		R&R-Invoice	METRO PARKWAY AGREEMENT
		003		\$3,600.00					
		PARKS & RECREATION		\$3,502.00		06/27/2017		R&R-Invoice	1627 BARRETT AVE INSTALL PLUMBING
		266001	03/29/2017	\$3,502.00					
		32 522907B05009016485		\$3,502.00					
		PUBLIC WORKS		\$3,414.48		06/27/2017		R&R-Invoice	SECURITY FOR O B CURTIS WTP
		12903	06/02/2017	\$3,414.48					
		31 521356420		\$3,414.48					
		PUBLIC WORKS		\$3,339.91		06/27/2017		R&R-Invoice	SECURITY SERVICES
		12875	06/02/2017	\$3,339.91					
		5 504106419		\$3,600.00					
		PARKS & RECREATION		\$3,600.00					
		5 504106419		\$3,600.00					
		PARKS & RECREATION		\$3,502.00					
		266001	03/29/2017	\$3,502.00					
		32 522907B05009016485		\$3,502.00					
		PUBLIC WORKS		\$3,414.48		06/27/2017		R&R-Invoice	SECURITY FOR O B CURTIS WTP
		12903	06/02/2017	\$3,414.48					
		31 521356420		\$3,414.48					
		PUBLIC WORKS		\$3,339.91		06/27/2017		R&R-Invoice	SECURITY SERVICES
		12875	06/02/2017	\$3,339.91					

VENDOR PAYMENTS / FOR CLAIM DOCKET - 06/27/2017
 Report Title - AMOUNTS (DESCENDING) ALL TYPES
 Invoice Payments Under \$5,000 - Over \$500

VEN#	VENDOR-NAME	INVOICE	INV-DATE	AMOUNT	AUTHORIZATION	DUPLICATE	REF-NUMBER	PAYMENT-TYPE	REMARKS
69303	CAPITAL CITY SECURITY INC	ADMINISTRATION	06/02/2017	\$3,339.91				R&R-Invoice	SECURITY SERVICE
20377	ENTERGY	PARKS & RECREATION	06/27/2017	\$3,304.06				R&R-Invoice	
46403	PETTY CASH-FINANCE/WKS COMP	PLANNING & DEVELOPMENT	06/12/2017	\$3,129.64				R&R-Invoice	TEMPORARY TOTAL DISABILITY
63034	BRANSON STANLEY R	GENERAL GOVERNMENT	06/19/2017	\$3,055.69				R&R-Invoice	BENEFITS - ANGELA ADAMS
20377	ENTERGY	PARKS & RECREATION	06/27/2017	\$3,000.00				R&R-Invoice	PROVIDE DJ SOUND & ENTERTAINME
65356	LOOMIS FARGO CO	PARKS & RECREATION	06/12/2017	\$2,827.71			0.1	R&R-Invoice	ELECTRIC LIGHT AND POWER
12636	NATCHEZ ELECTRIC	PUBLIC WORKS	05/30/2017	\$2,650.00				R&R-Invoice	ARMORED CAR SERVICE
67335	JACKSON REDEVELOPMENT AUTHORI	APR & MAY 2017	05/25/2017	\$2,590.00				R&R-Invoice	ALFRED LUCKETT & JOHN NOEL JR
63048	A-1 TRANSMISSION INC	GENERAL GOVERNMENT	05/26/2017	\$2,500.00				Limited-PO	PROFESSIONAL SERVICES
72625	DENT AIR CONDITIONING CO	PUBLIC WORKS	03/29/2017	\$2,475.00				R&R-Invoice	OVERHAUL TRANSMISSION PT737
06371	PETTY CASH-FINANCE/TRAVEL	GENERAL GOVERNMENT	03/31/2017	\$2,420.56				R&R-Invoice	DENVER, CO
72165	LAWRENCE CEDRIC DBA	PT 737 REPAIR TRANSMISSION	06/05/2017	\$2,400.00				R&R-Invoice	1162 ARBOR VISTA BLVD INSTALL
69303	CAPITAL CITY SECURITY INC	PUBLIC WORKS	06/02/2017	\$2,370.26				R&R-Invoice	PLUMBING
20377	ENTERGY	PLANNING & DEVELOPMENT	06/27/2017	\$2,448.96				R&R-Invoice	HOTEL-M. BATTLE- DAY
53785	WEST PAYMENT CENTER	GENERAL GOVERNMENT	03/31/2017	\$2,448.96				R&R-Invoice	DENVER, CO
72165	LAWRENCE CEDRIC DBA	PT 737 REPAIR TRANSMISSION	06/05/2017	\$2,400.00				R&R-Invoice	835871626 & 83960916 FOR WEST
69303	CAPITAL CITY SECURITY INC	PUBLIC WORKS	06/02/2017	\$2,370.26				R&R-Invoice	THROUGH MAR 31 2017
69303	CAPITAL CITY SECURITY INC	PUBLIC WORKS	06/02/2017	\$2,370.26				R&R-Invoice	INFORMATION CHARGES MAR 1 2017
69303	CAPITAL CITY SECURITY INC	PUBLIC WORKS	06/02/2017	\$2,370.26				R&R-Invoice	DEMOS 547 QUEEN PARK CIRCLE
69303	CAPITAL CITY SECURITY INC	PUBLIC WORKS	06/02/2017	\$2,370.26				R&R-Invoice	SECURITY SERVICES

AP755
 VENDOR PAYMENTS / FOR CLAIM DOCKET - 06/27/2017
 Report Title - AMOUNTS (DESCENDING) ALL TYPES
 Invoice Payments Under \$5,000 - Over \$500

VEN#	VENDOR-NAME	INVOICE	INV-DATE	AMOUNT	AUTHORIZATION	DUE-DATE	REF-NUMBER	PAYMENT-TYPE	REMARKS
71867	HINDS COUNTY CIRCUIT CLERK	061417	06/14/2017	\$2,295.00		06/27/2017		R&R-Invoice	PERMANENT EASEMENT FOR
	148 44890915009016723	PUBLIC WORKS		\$2,295.00					WEST COUNTY LINE RD PROJECT
14420	REVELL HARDWARE COMPANY INC	122389/6	06/07/2017	\$2,275.00		06/27/2017		Regular-PO	GORILLA GRIP GLOVES
	1 1502	Assets		\$2,275.00					
	PJ 1131 GORRILLA GRIP								
	001 *C01606	QUOTE--NO SLIP GLOVES - GORILL		500.000	Received	\$2,275.00			
72000	ALEXANDER LAW P A	061517	06/15/2017	\$2,272.00		06/27/2017		R&R-Invoice	JULY 2017 MONTHLY MORTGAGE
	18 518206722	GENERAL GOVERNMENT		\$2,272.00					PAYMENT
50265	SIEMENS BUILDING TECHN, INC.	5444569413	05/23/2017	\$2,247.35		06/27/2017		Limited-PO	REPLACED HIGH PRESSURE SWITCH
	1 453006461	PUBLIC WORKS		\$2,247.35					ERANT BACK TO SYSTEM
									PULLED VACUUM AND ADDED REFRIG
									MECHANIC WORK OVERTIME
	LJ 1656 EUDORA WELTY LIBRARY			\$2,247.35					
	001	MECHANIC CHARGE		1.000	Invoiced	\$1,763.50			
	002	TRIP CHARGE		1.000	Invoiced	\$60.00			
	003	MATERIAL CHARGE		1.000	Invoiced	\$423.85			
46403	PETTY CASH-FINANCE/WKS COMP	4139	06/12/2017	\$2,235.01		06/27/2017		R&R-Invoice	TEMPORARY TOTAL DISABILITY
	1 407926766	GENERAL GOVERNMENT		\$2,235.01					BENEFITS - ERIC MORRIS
10900	MERCHANTS COMPANY	9134099	05/15/2017	\$2,102.78		06/27/2017		Limited-PO	FOOD FOR WESTSIDE
	81 598726227	HUMAN & CULTURAL SERVICES		\$2,102.78					
	LJ 1577 FOOD ORDER FOR WESTSIDE EARLY CHILDHOOD CENTER			\$2,383.84					
	001	SLICED AMERICAN YELLOW CHEESE,		1.000	Received	\$44.90			
	002	YOGURT, STRAWBERRY BASH		1.000	Received	\$17.50			
	003	YOGURT, PEACH		1.000	Received	\$22.90			
	004	SOY MILK		1.000	Cancelled	\$29.90			
	005	SALAD MIX-RED CABBAGE AND SHRE		1.000	Received	\$21.90			
	006	BROCCOLI CUTS		1.000	Received	\$27.50			
	007	CORN ON COB		1.000	Received	\$19.98			
	008	POTATO WEDGES, FROZEN SEASONED		1.000	Received	\$32.90			
	009	JUICE BARS		1.000	Cancelled	\$18.96			
	010	CANTALOUPE		1.000	Received	\$30.00			
	011	STRAWBERRIES		2.000	Received	\$72.00			
	012	BANANAS		1.000	Received	\$22.90			
	013	ORANGES		1.000	Cancelled	\$29.90			
	014	TOMATOES		1.000	Received	\$22.90			
	015	GOLDEN APPLES		1.000	Received	\$36.90			
	016	CEREAL, HONEY NUT CHERRIOS - G		2.000	Received	\$71.80			
	017	CEREAL, RICE KRISPIES - KELLOG		1.000	Received	\$15.99			
	018	CEREAL, APPLE CINNAMON CHERRIO		1.000	Received	\$38.90			
	019	CEREAL, CHERRIOS, PLAIN - GENE		1.000	Received	\$37.50			
	020	FRENCH TOAST STICKS		2.000	Received	\$31.80			
	021	GRANOLA BAR FRUIT		2.000	Received	\$45.80			

AP755

VENDOR PAYMENTS / FOR CLAIM DOCKET - 06/27/2017
 Report Title - AMOUNTS (DESCENDING) ALL TYPES
 Invoice Payments Under \$5,000 - Over \$500

VEN#	VENDOR-NAME	INVOICE	INV-DATE	AMOUNT	AUTHORIZATION	DUE-DATE	REF-NUMBER	PAYMENT-TYPE	REMARKS
022		COOKIES, HONEY GRAHAM CRACKERS		1.000	Received	\$22.90			
023		COOKIES, VANILLA WAFERS OR COM		1.000	Received	\$11.99			
024		FIG NEWTON		1.000	Received	\$40.90			
025		TEDDY GRAHAM		1.000	Received	\$35.40			
026		ANIMAL CRACKERS		2.000	Received	\$32.58			
027		GOLDISH, CHEDDAR		1.000	Received	\$48.77			
028		BAKED CHEETOS		1.000	Cancelled	\$29.90			
029		SUN HARVEST CHIPS CHEDDAR		1.000	Received	\$27.80			
030		APPLESAUCE		1.000	Received	\$24.90			
031		PEACH, SLICES, LIGHT SYRUP		1.000	Received	\$34.90			
032		PEARS, DICED, LIGHT SYRUP		1.000	Received	\$35.50			
033		PINEAPPLE CHUNKS		1.000	Received	\$29.90			
034		BEANS, GREENS, CUT, CANS, 35V		1.000	Received	\$19.30			
035		CARROTS, SLICED		1.000	Received	\$20.90			
036		PEAS, GREENS, EARLY JUNE 35V		1.000	Received	\$28.90			
037		WHOLE KERNEL CORN		1.000	Received	\$22.90			
038		TROPICAL FRUIT		1.000	Received	\$36.90			
039		MANDARIN ORANGES		1.000	Received	\$29.40			
040		FRUIT JUICE, ORANGE, CANS 100%		1.000	Received	\$29.50			
041		FRUIT JUICE, PINEAPPLE, CANS		1.000	Received	\$28.50			
042		FRUIT JUICE, GRAPE CANS, 100%		1.000	Received	\$31.90			
043		WELCH'S FRUIT SNACKS, REAL FRU		2.000	Received	\$52.00			
044		BAR-B-Q BEEF		1.000	Received	\$58.90			
045		BEEF STEAK SALISBURY, PURE 80/		1.000	Received	\$44.90			
046		BEEF, GROUND, Patties, PURE 80		2.000	Received	\$55.80			
047		BEEF STEAK & PEPPER, CHOPPED		1.000	Received	\$26.90			
048		BEEF FINGER, BREADED PRECOOKED		2.000	Received	\$53.80			
049		COD, OVEN BAKED		1.000	Received	\$25.90			
050		TYSON BREADED, CHICKEN STRIPS		1.000	Received	\$24.90			
051		CHICKEN NUGGETS BREADED		2.000	Received	\$41.80			
052		PIZZA, FIESTADA - TONY'S OR EQ		1.000	Received	\$69.90			
053		FROZEN DOUGH DINNER ROLL SOFT		1.000	Received	\$27.90			
054		HAM DELI SLICED		1.000	Received	\$40.90			
055		CHICKEN, GRILLED SOUTHWESTERN		1.000	Received	\$47.90			
056		TURKEY, DELI SLICED		1.000	Received	\$46.50			
057		BISCUITS, DOUGH-RAW, PRE-CUT A		1.000	Received	\$26.90			
058		WHEAT BREAD		2.000	Received	\$59.80			
059		WHOLE GRAIN HAMBURGER BUNS		1.000	Received	\$25.90			
060		WHOLE GRAIN HOT DOG BUNS		1.000	Received	\$25.90			
061		APPLE MUFFINS		2.000	Cancelled	\$47.92			
062		CROISSANT WHOLE GRAIN FULLY CU		1.000	Cancelled	\$44.90			
063		BLUEBERRY MUFFINS		2.000	Cancelled	\$47.98			

AP755 VENDOR PAYMENTS / FOR CLAIM DOCKET - 06/27/2017
 Report Title - AMOUNTS (DESCENDING) ALL TYPES
 Invoice Payments Under \$5,000 - Over \$500

VEN#	VENDOR-NAME	INVOICE	INV-DATE	AMOUNT	AUTHORIZATION	DUE-DATE	REF-NUMBER	PAYMENT-TYPE	REMARKS
72002	GRESHAM SMITH & PARTNERS MS PC	0706737	06/08/2017	\$2,083.30		06/27/2017		Contract-PO	0706737
	213 451904B40026016413	PUBLIC WORKS		\$2,083.30					TERRY ROAD
	CI	45 TERRY ROAD RESURFACING PROJECT		\$108,009.06					
	001	TERRY ROAD RESURFACING PROEJC		108,009.060	Pt Invoiced	\$108,009.06			
72625	DENT AIR CONDITIONING CO	266535	04/19/2017	\$2,050.00		06/27/2017		R&R-Invoice	307 BARNES ST INSTALL PLUMBING
	32 522907B05009016485	PUBLIC WORKS		\$2,050.00					
15170	SHACK'S WELDING SERVICE	15592	05/11/2017	\$2,015.00		06/27/2017		Limited-PO	15592 REPAIR LOADING
	31 521406316	PUBLIC WORKS		\$1,650.00					REPALCE BOTTOM ON REAR BACKHOE
	31 521406316	PUBLIC WORKS		\$365.00					RAMPS ON TRAILER
									BUCKET OFF T-198
LJ	1588 T 198	REPLACE BOTTON ON REAR BACKHOE	TR 301 LOADING RAMP	\$2,015.00	Received	\$1,650.00			
	001	INVOICE 15592	T 198 REPLACE BO	1.000	Received	\$365.00			
	002	INVOICE 15592	REPAIR LOADING R	1.000	Received	06/27/2017		Limited-PO	FOOD FOR JONES DAY CARE
10900	MERCHANTS COMPANY	9154022	05/29/2017	\$1,762.19					
	81 598516227	HUMAN & CULTURAL SERVICES		\$1,762.19					
LJ	1707	FOOD ORDER FOR JONES	EARLY CHILDHOOD CENTER	\$1,808.19	Received	\$42.90			
	001	SLICED AMERICIAN YELLOW CHEESE,		1.000	Received	\$15.70			
	002	MARGARINE, SOLID, ALL VEGETABL		1.000	Received	\$16.50			
	003	YOGURT, STRAWBERRY BASH		1.000	Received	\$20.90			
	004	CORN ON COB		1.000	Received	\$32.90			
	005	POTATO WEDGES, FROZEN SEASONED		1.000	Received	\$26.50			
	006	POTATO, TATER TOTS		2.000	Received	\$29.90			
	007	STRAWBERRIES		1.000	Received	\$18.90			
	008	ORANGES		2.000	Received	\$15.99			
	009	SALAD MIX		2.000	Received	\$37.50			
	010	CEREAL, HONEY NUT CHERRIOS - G		1.000	Received	\$88.88			
	011	CEREAL, RICE KRISPIES - KELLOG		1.000	Received	\$20.50			
	012	CEREAL, APPLE CINNAMON CHERRIO		1.000	Received	\$31.90			
	013	CEREAL, CHERRIOS, PLAIN - GENR		1.000	Received	\$28.50			
	014	GRANOLA BAR FRUIT		1.000	Received	\$11.90			
	015	GRITS, QUICK		1.000	Received	\$40.90			
	016	QUICK OATMEAL		1.000	Received	\$20.65			
	017	COOKIES, HONEY GRAHAM CRACKERS		1.000	Received	\$70.80			
	018	COOKIES, VANILLA WAFERS OR COM		1.000	Received	\$57.70			
	019	FIG NEWTON		1.000	Received	\$32.58			
	020	CRACKERS, RITZ		1.000	Received				
	021	TEDDY GRAHAM		2.000	Received				
	022	CHEESE NIPS		2.000	Received				
	023	ANIMAL CRACKERS		2.000	Received				

AP755
 VENDOR PAYMENTS / FOR CLAIM DOCKET - 06/27/2017
 Report Title - AMOUNTS (DESCENDING) ALL TYPES
 Invoice Payments Under \$5,000 - Over \$500

VEN#	VENDOR-NAME	INVOICE	INV-DATE	AMOUNT	AUTHORIZATION	DUE-DATE	REF-NUMBER	PAYMENT-TYPE	REMARKS
024		BAKED CHEETOS		1.000	Received	\$29.99			
025		NACHO DORITOS		1.000	Received	\$29.99			
026		APPLESAUCE		1.000	Received	\$24.90			
027		PEACH, SLICES, LIGHT SYRUP		1.000	Received	\$34.90			
028		PINEAPPLE CHUNKS		1.000	Received	\$29.90			
029		MANDARIN ORANGES		1.000	Received	\$19.40			
030		BAKED BEANS		1.000	Received	\$31.90			
031		PEAS, GREENS, EARLY JUNE 3SV		1.000	Received	\$28.90			
032		MAYONNAISE, HEAVY DUTY		1.000	Received	\$24.90			
033		BEEF STEAK SALISBURY, PURE 80		1.000	Received	\$41.90			
034		BEEF GROUND, PATTIES, PURE 80		1.000	Received	\$27.90			
035		BEEF FINGER, BREADED PRECOOKED		1.000	Received	\$26.90			
036		TYSON BREADED, CHICKEN STRIPS		1.000	Received	\$24.90			
037		CHICKEN NUGGETS BREADED		1.000	Received	\$20.90			
038		PIZZA, FIESTADA - TONY'S OR EQ		1.000	Received	\$69.90			
039		FROZEN DOUGH DINNER ROLL SOFT		1.000	Received	\$27.90			
040		FRESH TURKEY HAM		1.000	Received	\$31.51			
041		BURRITOS, BEEF & BEAN		1.000	Received	\$26.90			
042		CHICKEN, GRILLED SOUTHWESTERN		1.000	Received	\$47.90			
043		CHICKEN, PATTIES, PRECOOKED		1.000	Received	\$27.90			
044		TURKEY DELI SLICED		1.000	Received	\$46.50			
045		MUFFINS, BLUEBERRY, ENRICHED F		2.000	Received	\$47.80			
046		WHEAT BREAD		2.000	Received	\$59.80			
047		WHOLE GRAIN HAMBURGER BUNS		1.000	Received	\$25.90			
048		WHOLE GRAIN HOT DOG BUNS		1.000	Received	\$24.90			
049		BANANA MUFFINS		2.000	Received	\$51.80			
050		APPLE MUFFINS		2.000	Cancelled	\$46.00			
051		CROISSANT WHOLE GRAIN FULLY CU		1.000	Received	\$44.90			
46403	PETTY CASH-FINANCE/WKS COMP	4140	06/12/2017	\$1,759.81		06/27/2017		R&R-Invoice	TEMPORARY TOTAL DISABILITY
	1 407926766	GENERAL GOVERNMENT		\$1,759.81					BENEFITS - DEVONTA RECTO
69397	SBB CONSTRUCTION LLC	12661	05/19/2017	\$1,721.39		06/27/2017		Regular-PO	LABOR TO REMOVE DAMAGED TILES
	1 436006419	HUMAN & CULTURAL SERVICES		\$864.29					WITH NEW R & R TRANSITIONAL
	1 436006317	HUMAN & CULTURAL SERVICES		\$857.10					ALONG THE EDGE AND REPLACE
									STRIPS MATERIALS ADHESIVE FOR
	PU 1052 Labor and Materials For Floor			\$1,721.39					
	001	LABOR TO REMOVE DAMAGED TILES		1.000	Received	\$864.29			
	002	MATERIALS; AHESIVE FOR STRIPS,		1.000	Received	\$857.10			
16075	ST DOMINIC HOSPITAL	5558380001	04/06/2017	\$1,718.18		06/27/2017		R&R-Invoice	JAMES MARY(14J-263WC) 00
	1 407926481	GENERAL GOVERNMENT		\$1,718.18					041417 041717 041917 042117
									040617 040717 041017 041217
									042617 & 042817
66485	STAFFERS INC	65461	06/16/2017	\$1,712.78		06/27/2017		R&R-Invoice	TEMPS KEONIA BUCKHALTER AND

VENDOR PAYMENTS / FOR CLAIM DOCKET - 06/27/2017
 Report Title - AMOUNTS (DESCENDING) ALL TYPES
 Invoice Payments Under \$5,000 - Over \$500

VEN#	VENDOR-NAME	INVOICE	INV-DATE	AMOUNT	AUTHORIZATION	DUE-DATE	REF-NUMBER	PAYMENT-TYPE	REMARKS
67698	C-SPIRE WIRELESS	MPSIC UTILITY ID0900	05/01/2017	\$1,709.50		06/27/2017		R&R-Invoice	JACQUELINE EDWARDS 0072330654 PHONE SERVICE
67954	EMSL ANALYTICAL INC	PUBLIC SAFETY - POLICE	06/02/2017	\$1,709.50		06/27/2017		R&R-Invoice	ASBESTOS TESTING 25101838
71805	EJES INC	PUBLIC SAFETY - POLICE	06/08/2017	\$1,695.00		06/27/2017		R&R-Invoice	25101903 25101985
	CI 47 COUNTRY CLUB DRIVE BRIDGE REPLACEMENT	PUBLIC WORKS	05/05/2017	\$1,630.69		06/27/2017		Contract-PO	4 COUNTRY CLUB DRIVE REPLACEMENT
	001 COUNTRY CLUB DRIVE BRIDGE REPL		02/20/2017	\$32,352.26	Invoiced	06/27/2017		R&R-Invoice	332,352.26
72625	DENT AIR CONDITIONING CO	PUBLIC WORKS	02/20/2017	\$1,625.00		06/27/2017		R&R-Invoice	338 ARBOR VISTA BLDV INSTALL PLUMBING
60823	MEA DRUG TESTING CONSORTIUM	PERSONNEL	05/31/2017	\$1,624.00		06/27/2017		R&R-Invoice	RANDOM/POST ACCIDENT-DRUG SCREEN
08555	HYDRAULIC SERVICE & SUPPLY	PUBLIC WORKS	05/05/2017	\$1,568.72		06/27/2017		Limited-PO	REPAIR PUMP
	LJ 1530 TK 710 and TK 565 REPAIR LOOSE WIRE		06/15/2017	\$246.50		06/27/2017		R&R-Invoice	MOVING EXPENSE
	001 INVOICE 109770 TK 710 REPAIR L		06/15/2017	\$1,322.22	Received	06/27/2017		R&R-Invoice	
	002 INVOICE 109740 TK 565 REPAIR H		06/15/2017	\$1,488.12	Received	06/27/2017		R&R-Invoice	
B2003	MITCHELL ALICIA	PUBLIC WORKS	06/12/2017	\$1,550.00		06/27/2017		R&R-Invoice	TRAVEL ADVANCE-WILSON/BLAKENEY FORT WORTH, TX
06371	PETTY CASH-FINANCE/TRAVEL	ADMINISTRATION	06/12/2017	\$1,543.88		06/27/2017		R&R-Invoice	
20377	ENTERGY	PARKS & RECREATION	06/27/2017	\$1,488.12		06/27/2017	16668634	UTILITY-PAYM	
	0+16668378 5 504106451	PARKS & RECREATION	04/30/2017	\$1,434.30		06/19/2017	0.1	R&R-Invoice	\$1,488.12 ELECTRIC LIGHT AND POWER
47027	MUNICIPAL SERVICES BUREAU	Liabilities	2016-1704	\$1,425.00		06/27/2017		R&R-Invoice	COLLECTION AGENCY MUN COURT
72636	FISHER LEE	PUBLIC SAFETY - POLICE	06/19/2017	\$1,425.00		06/27/2017		R&R-Invoice	BOARD UP 3222 BEATRICE DR
66485	STAFFERS INC	PUBLIC WORKS	06/09/2017	\$1,418.68		06/27/2017		R&R-Invoice	TEMP:JOANN MOORE & SHIRLEY MOORE
71586	TRILLIUM SOLUTIONS INC	PLANNING & DEVELOPMENT	06/12/2017	\$1,400.00		06/27/2017		R&R-Invoice	ANNUAL GTFMS MANAGEMENT 01/082017-01082018
03481	CAPITOL TOWING INC	PUBLIC SAFETY - POLICE	05/31/2017	\$1,385.00		06/27/2017		R&R-Invoice	SUBSCRIPTION & SUPPORT WRECKER SERVICES 82839 82736
72636	FISHER LEE	PUBLIC SAFETY - POLICE	06/19/2017	\$1,377.00		06/27/2017		R&R-Invoice	85088 85023 GRASS 5537-41 ROBINSON RD
06460	FLANNIGAN ELECTRIC CO INC	PUBLIC WORKS	04/27/2017	\$1,331.17		06/27/2017		R&R-Invoice	EMERGENCY REPAIR FOR GEARBOX MOTOR
72636	FISHER LEE	PUBLIC WORKS	06/19/2017	\$1,310.00		06/27/2017		R&R-Invoice	BOARD UP 1637 GIBRALTAR DR

VENDOR PAYMENTS / FOR CLAIM DOCKET - 06/27/2017
 Report Title - AMOUNTS (DESCENDING) ALL TYPES
 Invoice Payments Under \$5,000 - Over \$500

VEN#	VENDOR-NAME	INVOICE	INV-DATE	AMOUNT	AUTHORIZATION	DUE-DATE	REF-NUMBER	PAYMENT-TYPE	REMARKS
70053	BUSINESS & OFFICE KONNECTIONS	5664	06/07/2017	\$1,300.00		06/27/2017		Regular-PO	REMOVING EXISTING SWINGS
	81 598106419			\$1,300.00					
	PJ 1158 REMOVING EQUIPMENT FOR EARLY CHILDHOOD			\$1,300.00					
	001	REMOVES EXISTING SWINGS AT WES		2.000	Received	\$1,300.00			
40049	WAGGONER ENGINEERING INC	CO16005-006	05/25/2017	\$1,270.57		06/16/2017		Contract-PO	CO16005-006
	173 451355B40107016413	PUBLIC WORKS		\$1,270.57					RIVERSIDE DRIVE PH1
	CJ 2 RIVERSIDE DRIVE ROAD IMP, PH1 (FM PEACHTREE ST TO I-55 BRD			\$965,000.00					
	001	RIVERSIDE DRIVE ROAD IMP, PH1		965,000.000	Pt Invoiced	\$965,000.00			
60583	DPS CRIME LAB	90061026	06/05/2017	\$1,260.00		06/27/2017		R&R-Invoice	ANALYTICAL FEES
	1 442256419	PUBLIC SAFETY - POLICE		\$1,260.00					
69239	MOMENT RICHARD DBA R & L	06152017	06/15/2017	\$1,260.00		06/27/2017		R&R-Invoice	CUTTING GRASS AND WEEDS: 209
	1 442716447	PUBLIC SAFETY - POLICE		\$1,260.00					LOUISIANA AVENUE(2016-1676)
69303	CAPITAL CITY SECURITY INC	12891	06/02/2017	\$1,232.17		06/27/2017		R&R-Invoice	12891 & 12892 SECURITY FOR
	81 598106419	HUMAN & CULTURAL SERVICES		\$1,232.17					EARLY CHILDHOOD CENTERS
61831	NAPA AUTO PARTS	JAC00037019717	06/07/2017	\$1,215.98		06/07/2017		R&R-Invoice	MUNICIPAL GARAGE
	1 442406316	PUBLIC SAFETY - POLICE		\$5.54					
	1 442406316	PUBLIC SAFETY - POLICE		\$433.19					
	1 442406316	PUBLIC SAFETY - POLICE		\$41.10					
	1 442406316	PUBLIC SAFETY - POLICE		\$38.88					
	1 442406316	PUBLIC SAFETY - POLICE		\$248.88					
	1 442406316	PUBLIC SAFETY - POLICE		\$19.98					
	1 442406316	PUBLIC SAFETY - POLICE		\$2.21					
	1 442406316	PUBLIC SAFETY - POLICE		\$44.40					
	1 442406316	PUBLIC SAFETY - POLICE		\$9.95					
	1 442406316	PUBLIC SAFETY - POLICE		\$6.66					
	1 442406316	PUBLIC SAFETY - POLICE		\$16.62					
	1 442406316	PUBLIC SAFETY - POLICE		\$16.60					
	1 442406316	PUBLIC SAFETY - POLICE		\$7.77					
	1 442406316	PUBLIC SAFETY - POLICE		\$64.44					
	1 442406316	PUBLIC SAFETY - POLICE		\$1.55					
	1 442406316	PUBLIC SAFETY - POLICE		\$2.95					
	1 442406316	PUBLIC SAFETY - POLICE		\$21.98					
	1 442406316	PUBLIC SAFETY - POLICE		\$233.28					
42781	DIGITEC CORPORATION	98807	05/16/2017	\$1,198.10		06/27/2017		R&R-Invoice	COPIER RENTAL
	1 414106514	ADMINISTRATION		\$1,198.10					
40994	SUNBELT FIRE APPARATUS INC	305138	06/02/2017	\$1,142.32		06/27/2017		Limited-PO	TURN SIG SW TILT FREIGHT
	1 441206316	FIRE DEPARTMENT		\$1,142.32					LED 44308C MDL 44 KIT
				\$1,142.32					HP91523933 2.5 WHITE LP TRK
				\$1,142.32					LIFLITE 12 LED ON/OFF BOT
LJ	1738 TK 683 Lights	Lights		\$1,142.32					
	001	Lights		1.000	Received	\$1,142.32			

AP755 VENDOR PAYMENTS / FOR CLAIM DOCKET - 06/27/2017
 Report Title - AMOUNTS (DESCENDING) ALL TYPES
 Invoice Payments Under \$5,000 - Over \$500

VEN#	VENDOR-NAME	INVOICE	INV-DATE	AMOUNT	AUTHORIZATION	DUE-DATE	REF-NUMBER	PAYMENT-TYPE	REMARKS
69860	PRAIRIE FARMS	0430501175063371	05/01/2017	\$1,139.00		06/27/2017		Limited-PO	MILK FOR JONES DAYCARE CENTER
	81 598516227	HUMAN & CULTURAL SERVICES		\$1,139.00					
	LJ 1779 MILK ORDER FOR JONES EARLY CHILDHOOD CENTER			\$1,139.00					
	001	WHOLE PLST MILK		1,150.000	Received	\$385.25			
	002	1% PLST 50 MILK		2,250.000	Received	\$753.75			
66800	LEWIS ELECTRIC INC	M201724	05/07/2017	\$1,100.00		06/27/2017		Regular-PO	TRAFFIC SIGNAL CONTROLLER
	1 448206315	PUBLIC WORKS		\$1,100.00					
	PJ 1064 TRAFFIC SIGNAL CONTROLLER EPAC 300			\$1,100.00					
	001	(QUOTE) TRAFFIC SIGNAL CONTR		1,000	Received	\$1,100.00		Limited-PO	CUSTOM FITTINGS FOR TRUCK
08555	HYDRAULIC SERVICE & SUPPLY	109194	03/09/2017	\$1,091.50		06/27/2017			109198
	31 522206316	PUBLIC WORKS		\$996.50					
	31 522206316	PUBLIC WORKS		\$95.00					
	LJ 1080 REPAIR OF TC 64 & TK 775			\$1,091.50					
	001	INVOICE 109198 REPAIR OF TC 64		1,000	Received	\$996.50			
	002	INVOICE 109194 STANDOFF FITTI		1,000	Received	\$95.00			
66485	STAFFERS INC	65296	06/02/2017	\$1,052.80		06/27/2017		R&R-Invoice	TEMP STEPHANIE GUICE AND LUCINDA COOLEY
	4 904006419	ADMINISTRATION		\$1,052.80					
69860	PRAIRIE FARMS	0430509175073127	05/09/2017	\$1,051.74		06/27/2017		Limited-PO	MILK FOR WESTSIDE DAY CARE CENTER
	81 598726227	HUMAN & CULTURAL SERVICES		\$1,051.74					
	LJ 1780 MILK ORDER FOR WESTSIDE EARLY CHILDHOOD CENTER			\$1,051.74					
	001	WHOLE PLST MILK		350.000	Received	\$117.25			
	002	WHOLE PLST MILK		100.000	Received	\$64.38			
	003	1% PLST 50 PF MILK		2,350.000	Received	\$787.25			
	004	LFREE SKIM PFB MILK		99.000	Received	\$82.04			
	005	LFREE SKIM PFB MILK		1,000	Received	\$82			
60427	MIPCO IMPRESSION PRODUCTS INC	131819	06/01/2017	\$1,030.37		06/27/2017		R&R-Invoice	COPIER RENTAL
	31 520106514	PUBLIC WORKS		\$1,030.37					
	72635 JORDAN BARRY	2015-1499	06/05/2017	\$1,021.00		06/27/2017		R&R-Invoice	GRASS & WEEDS 2926 FAIRHILL DR
	1 442716447	PUBLIC SAFETY - POLICE		\$1,021.00					
71867	HINDS COUNTY CIRCUIT CLERK	GCC0217	06/15/2017	\$1,000.00		06/27/2017		R&R-Invoice	CSE 25C01:17CV00370 DOCUMENT
	148 44890915009016723	PUBLIC WORKS		\$1,000.00					78
71867	HINDS COUNTY CIRCUIT CLERK	GCC0317	06/15/2017	\$1,000.00		06/27/2017		R&R-Invoice	CASE 25C01:17CV00366 DOCUMENT
	148 44890915009016723	PUBLIC WORKS		\$1,000.00					#32
71867	HINDS COUNTY CIRCUIT CLERK	GCC0317A	06/15/2017	\$1,000.00		06/27/2017		R&R-Invoice	CASE 25C01:17CV00383 DOCUMENT
	148 44890915009016723	PUBLIC WORKS		\$1,000.00					#67
71867	HINDS COUNTY CIRCUIT CLERK	GCC0517	06/15/2017	\$1,000.00		06/27/2017		R&R-Invoice	CASE 25C01:17CV00369 DOCUMENT
	148 44890915009016723	PUBLIC WORKS		\$1,000.00					#56
72624	LEIS ART MD	2114	06/09/2017	\$1,000.00		06/27/2017		R&R-Invoice	MATORY CHERLIT (14J-116-WC) 001
	1 407926481	GENERAL GOVERNMENT		\$1,000.00					
06371	PETTY CASH-FINANCE/TRAVEL	13337	06/12/2017	\$995.00		06/27/2017		R&R-Invoice	REGISTRATION-FREDRICK WILSON FORT WORTH, TN
	4 904006443	ADMINISTRATION		\$995.00					
06371	PETTY CASH-FINANCE/TRAVEL	13348	06/12/2017	\$995.00		06/27/2017		R&R-Invoice	REGISTRATION-R. BLAKENEY

VENDOR PAYMENTS / FOR CLAIM DOCKET - 06/27/2017
 Report Title - AMOUNTS (DESCENDING) ALL TYPES
 Invoice Payments Under \$5,000 - Over \$500

VEN#	VENDOR-NAME	INVOICE	ADMINISTRATION	INV-DATE	AMOUNT	AUTHORIZATION	DUE-DATE	REF-NUMBER	PAYMENT-TYPE	REMARKS
AP755	4 904006443	05252017	GENERAL GOVERNMENT	05/25/2017	\$995.00		06/27/2017		R&R-Invoice	FORT WORTH, TX REIMBURSEMENT FOR SEWER CLEAN-PURSUANT
B1991	EDIE TRESSA	05252017	GENERAL GOVERNMENT	05/25/2017	\$995.00		06/27/2017		R&R-Invoice	UP AT 3700 KINGS HIGHWAY
09526	JEFCOAT FENCE CO INC	203529	PUBLIC WORKS	05/13/2017	\$985.00		06/27/2017		R&R-Invoice	REPAIRED BARBED WIRE CHAIN
46371	STANTON BODY SHOP	2603/05222017	PUBLIC SAFETY - POLICE	05/22/2017	\$980.80		06/27/2017		Limited-PO	REPLACE A/M AORP BUMPER COVER REPLC ENERGY ABSORBER W/O REV SENSOR ADD CLEAR COAT REPLC RT SIDE SUPPORT PARTS L
	LJ 1435 PC 1685 PAINT AND REPAIR REAR BUMBER	061217	PUBLIC SAFETY - POLICE	06/12/2017	\$980.80		06/27/2017		Limited-PO	
	001	061617	PUBLIC SAFETY - POLICE	06/16/2017	\$955.64		06/27/2017		R&R-Invoice	TTD BENEFITS 17J22WC001
72162	FOSTER MICHELLE	061617	GENERAL GOVERNMENT	06/16/2017	\$955.64		06/27/2017		R&R-Invoice	SOSNOSKIE ROBERT(16J-187-WC)00 011917 & 012417
31592	STATE OF MS UMMC	H160178626102	GENERAL GOVERNMENT	01/03/2017	\$950.40		06/27/2017		R&R-Invoice	010317 010517 011217 011717
	LJ 1696 OVERHAUL TRANSMISSION ON PT 664	PT 664 OVERHAUL TRANSMISSION	PUBLIC WORKS	06/12/2017	\$950.00		06/27/2017		Limited-PO	OVERHAUL TRANSMISSION
	001	041217	PUBLIC SAFETY - POLICE	04/12/2017	\$945.00		06/27/2017		Limited-PO	REPAIR TRANSMISSION
63048	A-1 TRANSMISSION INC	041217	PUBLIC SAFETY - POLICE	04/12/2017	\$945.00		06/27/2017		Limited-PO	
	LJ 1275 PC 1520 TRANSMISSION REBUILD	051217	PUBLIC SAFETY - POLICE	05/12/2017	\$945.00		06/27/2017		Limited-PO	OVERHAUL TRANSMISSION PCL557
	001	051217	PUBLIC SAFETY - POLICE	05/12/2017	\$945.00		06/27/2017		Limited-PO	
63048	A-1 TRANSMISSION INC	051217	PUBLIC SAFETY - POLICE	05/12/2017	\$945.00		06/27/2017		Limited-PO	
	LJ 1441 PC 1557 OVERHAUL TRANSMISSION	PC 1557 OVERHAUL TRANSMISSION	PUBLIC SAFETY - POLICE	05/15/2017	\$945.00		06/27/2017		Limited-PO	OVERHAUL TRANSMISSION PCL385
	001	051517	PUBLIC SAFETY - POLICE	05/15/2017	\$945.00		06/27/2017		Limited-PO	
63048	A-1 TRANSMISSION INC	051517	PUBLIC SAFETY - POLICE	05/15/2017	\$945.00		06/27/2017		Limited-PO	
	LJ 1442 PC 1385 OVERHAUL TRANSMISSION	PC 1385 OVERHAUL TRANSMISSION	PUBLIC SAFETY - POLICE	06/02/2017	\$945.00		06/27/2017		Limited-PO	OVERHAUL TRANSMISSION
	001	060217	PUBLIC SAFETY - POLICE	06/02/2017	\$945.00		06/27/2017		Limited-PO	
63048	A-1 TRANSMISSION INC	060217	PUBLIC SAFETY - POLICE	06/02/2017	\$945.00		06/27/2017		Limited-PO	
	LJ 1584 TRANSMISSION OVERHAUL FOR PC 1584	PC 1584 TRANSMISSION REPAIR	PUBLIC SAFETY - POLICE	06/16/2017	\$926.22		06/27/2017		R&R-Invoice	TTD BENEFITS 17J60WC001
	001	061617	GENERAL GOVERNMENT	06/16/2017	\$926.22		06/27/2017		R&R-Invoice	
72628	RECIO DEVONNA	061617	GENERAL GOVERNMENT	06/16/2017	\$924.30		06/27/2017		R&R-Invoice	TTD BENEFITS 17J33WC001
	LJ 1584 TRANSMISSION OVERHAUL FOR PC 1584	PC 1584 TRANSMISSION REPAIR	GENERAL GOVERNMENT	06/16/2017	\$924.30		06/27/2017		R&R-Invoice	
	001	2016-1696	GENERAL GOVERNMENT	06/05/2017	\$924.00		06/27/2017		R&R-Invoice	GRASS & WEEDS 5072 LURLINE DR
72146	SMITH MIRON B	061617	GENERAL GOVERNMENT	06/16/2017	\$924.00		06/27/2017		R&R-Invoice	
	LJ 1407926766	061617	GENERAL GOVERNMENT	06/16/2017	\$924.00		06/27/2017		R&R-Invoice	
72635	JORDAN BARRY	2016-1696	GENERAL GOVERNMENT	06/05/2017	\$924.00		06/27/2017		R&R-Invoice	

AP755 VENDOR PAYMENTS / FOR CLAIM DOCKET - 06/27/2017
 Report Title - AMOUNTS (DESCENDING) ALL TYPES
 Invoice Payments Under \$5,000 - Over \$500

VEN#	VENDOR-NAME	INVOICE	INV-DATE	AMOUNT	AUTHORIZATION	DUE-DATE	REF-NUMBER	PAYMENT-TYPE	REMARKS
20377	ENTERGY	1 442716447		\$924.00					
		16746083\	06/27/2017	\$917.31			16746406	UTILITY-PAYM	
		ADMINISTRATION		\$917.31					
71263	0+16746083 SIMMONS DEXTER	1 443106451	06/16/2017	\$908.84			0.1	\$917.31	ELECTRIC LIGHT AND POWER
		061617	06/16/2017	\$908.84				R&R-Invoice	TTD BENEFITS 14J172AC001
		GENERAL GOVERNMENT		\$903.88					
20377	ENTERGY	1 433006451	06/27/2017	\$903.88				UTILITY-PAYM	
		18293134\	06/27/2017	\$903.88			18293431		
		HUMAN & CULTURAL SERVICES		\$883.91					
20377	ENTERGY	0+18293134	06/27/2017	\$883.91			0.1	\$903.88	ELECTRIC LIGHT AND POWER
		19832187\	06/27/2017	\$883.91				UTILITY-PAYM	
		FIRE DEPARTMENT		\$864.78					
71777	BELL DERRICK	0+19832187	06/16/2017	\$864.78			0.1	\$883.91	ELECTRIC LIGHT AND POWER
		061617	06/16/2017	\$864.78				R&R-Invoice	TTD BENEFITS 15J01WC001
		GENERAL GOVERNMENT		\$860.00					
69239	MOMENT RICHARD DBA R & L	1 442716447	06/15/2017	\$860.00				R&R-Invoice	CUTTING GRASS AND WEEDS 0
		PUBLIC SAFETY - POLICE		\$859.96					(215-2281)
70053	BUSINESS & OFFICE KONNECTIONS	5690	06/14/2017	\$859.96				Regular-PO	JOHNSON COURT/LOT E OF 4228
		81 598106299		\$859.96					VINYL GLOVES
		HUMAN & CULTURAL SERVICES		\$859.96					
		PJ 1183 SUPPLIERS FOR ECD		10.000	Received	\$720.00			
		001		4.000	Received	\$139.96			
		QUOTE--GENERAL PURPOSE VINYL G							
		MULTIFOLD PAPER TOWELS ITEM# B							
61190	SOUTHERN HOSE & INDUSTRIAL INC	093906	04/20/2017	\$850.86					Limited-PO
		31 522206316		\$364.05					HYD JOINER CUT CRIMP AND ASS
		PUBLIC WORKS		\$193.96					1 MALE NPT BUNA-N CAMLOCK
		31 522206316		\$115.85					1" PIRAHNA 2500 MENDER 1 HBX
		PUBLIC WORKS		\$32.12					GASKET HOSE ASSEMBLY
		1 451256316		\$33.60					
		PUBLIC WORKS		\$61.98					
		31 522206316		\$49.30					
		PUBLIC WORKS		\$850.86					
		1 441206316							
		FIRE DEPARTMENT							
		LJ 1543 HOSE REPAIR FOR VARIOUS DEPARTMENT							
		001		1.000	Received	\$86.85			
		INVOICE 93906		1.000	Received	\$70.00			
		002		1.000	Received	\$115.85			
		INVOICE 094191		1.000	Received	\$101.22			
		003		1.000	Received	\$61.98			
		INVOICE 94564		1.000	Received	\$61.98			
		004		1.000	Received	\$32.12			
		INVOICE 094625		1.000	Received	\$111.98			
		005		1.000	Received	\$64.00			
		INVOICE 094746		1.000	Received	\$33.60			
		006		1.000	Received	\$61.98			
		INVOICE 94793		1.000	Received	\$33.60			
		007		1.000	Received	\$61.98			
		INVOICE 94008		1.000	Received	\$61.98			
		008		1.000	Received	\$32.12			
		INVOICE 95218		1.000	Received	\$111.98			
		009		1.000	Received	\$64.00			
		INVOICE 95240		1.000	Received	\$33.60			
		010		1.000	Received	\$61.98			
		INVOICE 095611		1.000	Received	\$61.98			
		011		1.000	Received	\$61.98			
		INVOICE 095511		1.000	Received	\$61.98			

AP755 VENDOR PAYMENTS / FOR CLAIM DOCKET - 06/27/2017
 Report Title - AMOUNTS (DESCENDING) ALL TYPES
 Invoice Payments Under \$5,000 - Over \$500

VEN#	VENDOR-NAME	INVOICE	INV-DATE	AMOUNT	AUTHORIZATION	DUE-DATE	REF-NUMBER	PAYMENT-TYPE	REMARKS
41410	TRUSTMARK NATIONAL BANK	INVOICE TK 681	06/19/2017	1,000	Received	06/27/2017		R&R-Invoice	TIF SERIES 2009 PAYING AGENT
72635	JORDAN BARRY	DEBT SERVICE	2015-1919	\$850.00		06/27/2017		R&R-Invoice	FEE
13820	R L POLK & CO	PUBLIC SAFETY - POLICE	05/22/2017	\$841.00		06/27/2017		R&R-Invoice	GRASS & WEEDS 3020 LAKEWOOD DR
		PUBLIC SAFETY - POLICE	05/22/2017	\$834.00		06/27/2017		Regular-PO	CITY DIRECTORIES
		PUBLIC SAFETY - POLICE	05/22/2017	\$556.00		06/27/2017			
		PUBLIC WORKS	06/16/2017	\$278.00		06/27/2017			
		PUBLIC WORKS	06/16/2017	\$834.00		06/27/2017			
66723	SURGICARE OF JACKSON	JACKSON CROSS REFERENCE DIRECT	04/24/2017	\$833.41	Received	06/27/2017		R&R-Invoice	BELL DERRICK(15J-01-WC) 00
		GENERAL GOVERNMENT	06/16/2017	\$833.41		06/27/2017		R&R-Invoice	TTD BENEFITS 17J51WC001
72627	ADAMS ANGELA	GENERAL GOVERNMENT	06/12/2017	\$825.86		06/27/2017		R&R-Invoice	HOTEL-M, BATTLE-DAY
06371	PETTY CASH-FINANCE/TRAVEL	ADMINISTRATION	06/27/2017	\$816.32		06/27/2017		R&R-Invoice	DENVER, CO
20377	ENTERGY	16668865\	06/27/2017	\$805.02		06/27/2017	16669152	UTILITY-PAYM	
		PARKS & RECREATION	11/01/2016	\$800.00		06/27/2017	0.1	\$805.02	ELECTRIC LIGHT AND POWER
72629	RON TURLEY ASSOCIATES INC	PLANNING & DEVELOPMENT	06/02/2017	\$795.60		06/27/2017		R&R-Invoice	ANNUAL MAINTENANCE AGREEMENT
69303	CAPITAL CITY SECURITY INC	PUBLIC WORKS	04/12/2017	\$785.58		06/27/2017		R&R-Invoice	SECURITY SERVICES
07180	W W GRAINGER INC	Assets	06/27/2017	\$785.58		06/27/2017		Regular-PO	BOLT CUTTER STEEL
		BOLT CUTTER, 36" (SEE EXTRA DE	02/02/2017	\$775.60	Received	02/02/2017		R&R-Invoice	MUNICIPAL GARAGE
61831	NAPA AUTO PARTS	PUBLIC WORKS	06/19/2017	\$355.24		06/27/2017		R&R-Invoice	
		PUBLIC WORKS	06/19/2017	\$69.34		06/27/2017			
		PUBLIC WORKS	06/19/2017	\$152.36		06/27/2017			
		PUBLIC WORKS	06/19/2017	\$71.56		06/27/2017			
		PUBLIC WORKS	06/19/2017	\$35.84		06/27/2017			
		PUBLIC WORKS	06/19/2017	\$91.26		06/27/2017			
20377	ENTERGY	16029241\	06/27/2017	\$758.54		06/27/2017	16029472	UTILITY-PAYM	
		FIRE DEPARTMENT	06/19/2017	\$758.54		06/27/2017			
59466	W W GRAINGER, INC	PUBLIC WORKS	05/05/2017	\$750.40		06/27/2017		R&R-Invoice	ELECTRIC LIGHT AND POWER
		PUBLIC WORKS	05/05/2017	\$750.40		06/27/2017		Limited-PO	WET/DRY VACUUMS
		Wet/Dry Vacuum Air Flow	06/16/2017	\$750.40	Invoiced	06/27/2017		R&R-Invoice	TTD BENEFITS 15J167WC001
71778	CARTER JASMINE		06/16/2017	\$747.86		06/27/2017		R&R-Invoice	

AP755 VENDOR PAYMENTS / FOR CLAIM DOCKET - 06/27/2017
 Report Title - AMOUNTS (DESCENDING) ALL TYPES
 Invoice Payments Under \$5,000 - Over \$500

VEN#	VENDOR-NAME	INVOICE	INV-DATE	AMOUNT	AUTHORIZATION	DUE-DATE	REF-NUMBER	PAYMENT-TYPE	REMARKS
67938	INTEGRATED PEST SERVICES 1 434206419	61884 HUMAN & CULTURAL SERVICES	06/06/2017	\$744.00 \$744.00		06/27/2017		R&R-Invoice	61884 62241 62431 61882 62238 62428 61869 62224 62426 61903 62457 61889 62418 PEST CONTROL FOR SENIOR SOSNOSKIE ROBERT (16J-187-WC)00 120216
31592	STATE OF MS UMMC 1 407926481	H10222769701 GENERAL GOVERNMENT	12/02/2016	\$739.23 \$739.23		06/27/2017		R&R-Invoice	PPD BENEFITS 16J100WC001
71976	BENNETT ROY L JR 1 407926766	061617 GENERAL GOVERNMENT	06/16/2017	\$738.46 \$738.46		06/27/2017		R&R-Invoice	HONDA WB30X PUMP SUCTION HOSE DISCHARGE HOSE
10860	MEL LUNA SAW CO 31 520206865	84588 PUBLIC WORKS	04/25/2017	\$734.90 \$734.90		06/27/2017		Regular-PO	
	PJ 947 WATER PUMP & HOSE 001	(QUOTE) HONDA WB30X PUMP		\$734.90	Received				
	002	20' SUCTION HOSE		1.000	Received				
	003	25' DISCHARGE HOSE		1.000	Received				
20377	ENTERGY 1 443106451	16242950\\ ADMINISTRATION	06/27/2017	\$729.37 \$729.37		06/27/2017	16340390	UTILITY-PAYM	
61831	NAPA AUTO PARTS 31 521406316	JAC00037019667 PUBLIC WORKS	06/05/2017	\$720.93 \$720.93		06/05/2017		R&R-Invoice	ELECTRIC LIGHT AND POWER MUNICIPAL GARAGE
10014	LAKELAND RADIOLOGIST P A 1 407926481	55693958 GENERAL GOVERNMENT	04/14/2017	\$711.12 \$711.12		06/27/2017		R&R-Invoice	BELL DERRICK(15J-01-WC)00 4142017
59466	W W GRAINGER, INC 1 441706464	9441245793 FIRE DEPARTMENT	05/10/2017	\$708.48 \$708.48		06/27/2017		Limited-PO	EXHAUST FAN
	LJ 1563 CENTRAL FIRE STATION 001	EXHAUST FAN		\$708.48	Invoiced				
53638	HALL'S TOWING SERVICE INC 1 442206465	401121 PUBLIC SAFETY - POLICE	05/18/2017	\$700.00 \$700.00		06/27/2017		R&R-Invoice	401121 400944 401577 WRECKER SERVICE 401793 401810 102074
72637	DAWSON ANGELA & JESSIE 1 442716447	2016-1893 PUBLIC SAFETY - POLICE	06/15/2017	\$695.00 \$695.00		06/27/2017		R&R-Invoice	GRASS & WEEDS 115 REBEL CIRCLE
71485	ANESTHESIA SERVICES ASSOCIATES 1 407926481	3027852 GENERAL GOVERNMENT	04/13/2017	\$682.40 \$682.40		06/27/2017		R&R-Invoice	WALKER VELISA F(13J-67-WC)00 041317
20377	ENTERGY 1 441706451	18258616\\ FIRE DEPARTMENT	06/27/2017	\$681.90 \$681.90		06/27/2017	18279331	UTILITY-PAYM	
20377	ENTERGY 0+18258616 1 441706451	19831767\\ FIRE DEPARTMENT	06/27/2017	\$674.33 \$674.33		06/27/2017	198318	UTILITY-PAYM	
06371	PETTY CASH-FINANCE/TRAVEL 85 855106473	13431A PUBLIC WORKS	06/12/2017	\$668.67 \$668.67		06/27/2017		R&R-Invoice	ELECTRIC LIGHT AND POWER HOTEL-CHARLES RICHARDSON GONZALES, LA
67981	INNOVATIVE STAFFING SERVICES 3721	PLANNING & DEVELOPMENT	06/05/2017	\$664.68		06/27/2017		R&R-Invoice	TEMP:PAMELA JOHNSON &

AP755 VENDOR PAYMENTS / FOR CLAIM DOCKET - 06/27/2017
 Report Title - AMOUNTS (DESCENDING) ALL TYPES
 Invoice Payments Under \$5,000 - Over \$500

VEN#	VENDOR-NAME	INVOICE	ADMINISTRATION	INV-DATE	AMOUNT	AUTHORIZATION	DUE-DATE	REF-NUMBER	PAYMENT-TYPE	REMARKS
61831	NAPA AUTO PARTS	1 442406316	JAC00037019730	06/08/2017	\$664.68		06/08/2017		R&R-Invoice	PATRICIA DAVIS
		1 442406316	PUBLIC SAFETY - POLICE		\$45.26					
		1 442406316	PUBLIC SAFETY - POLICE		\$55.53					
		1 442406316	PUBLIC SAFETY - POLICE		\$61.66					
		1 442406316	PUBLIC SAFETY - POLICE		\$59.45					
		1 442406316	PUBLIC SAFETY - POLICE		\$8.06					
		1 442406316	PUBLIC SAFETY - POLICE		\$87.99					
		1 442406316	PUBLIC SAFETY - POLICE		\$87.99					
		1 442406316	PUBLIC SAFETY - POLICE		\$2.23					
		1 442406316	PUBLIC SAFETY - POLICE		\$6.28					
		1 442406316	PUBLIC SAFETY - POLICE		\$12.75					
71420	DERMATRAN HEALTH SOLUTIONS LLC	052317		05/23/2017	\$654.52		06/27/2017		R&R-Invoice	DEXTER SIMMONS 05/23/17
		1 407926481	GENERAL GOVERNMENT		\$654.52					
20377	ENTERGY	1 442416451	60188810\	06/27/2017	\$653.69		06/27/2017	60378254	UTILITY-PAYM	
		1 442416451	PUBLIC SAFETY - POLICE		\$653.69					
20377	ENTERGY	1 442416451	133327908	06/27/2017	\$651.48		06/19/2017	0.1	\$653.69	ELECTRIC LIGHT AND POWER
		1 442416451	PUBLIC SAFETY - POLICE		\$651.48					
71879	CRAFT MILTON	061617		06/16/2017	\$650.90		06/27/2017		R&R-Invoice	TTD BENEFITS 17J45WC001
		1 407926766	GENERAL GOVERNMENT		\$650.90					
66097	PULLUM JERMAINE	061617		06/16/2017	\$645.80		06/27/2017		R&R-Invoice	TTD BENEFITS 02J234WC001
		1 407926766	GENERAL GOVERNMENT		\$645.80					
71795	COLLINS CHARLES	061617		06/16/2017	\$644.98		06/27/2017		R&R-Invoice	TTD BENEFITS 14J205WC001
		1 407926766	GENERAL GOVERNMENT		\$644.98					
61831	NAPA AUTO PARTS	JAC00037019631		06/01/2017	\$643.37		06/01/2017		R&R-Invoice	MUNICIPAL GARAGE
		1 442406316	PUBLIC SAFETY - POLICE		\$52.42					
		1 442406316	PUBLIC SAFETY - POLICE		\$41.36					
		1 442406316	PUBLIC SAFETY - POLICE		\$13.56					
		1 442406316	PUBLIC SAFETY - POLICE		\$86.63					
		1 442406316	PUBLIC SAFETY - POLICE		\$18.00					
		1 442406316	PUBLIC SAFETY - POLICE		\$18.00-					
		1 442406316	PUBLIC SAFETY - POLICE		\$4.60					
		1 442406316	PUBLIC SAFETY - POLICE		\$444.80					
71890	CANON FINANCIAL SERVICES	17446779		06/12/2017	\$634.52		06/27/2017		R&R-Invoice	COPIER RENTAL
		1 404106514	PLANNING & DEVELOPMENT		\$634.52					
70176	STANTEC CONSULTING SERVICES	1202426		05/31/2017	\$621.98		06/27/2017		Contract-PO	1202426
		216 44890315009056413	PUBLIC WORKS		\$621.98					ADA PROJECT
CJ	22 PREMINARY ENGINEERING SERVICES FOR THE ADA PROJECT				\$42,743.66					
		001	PREMINARY ENGINEERING SERVICES		\$42,743.66					
20445	AT & T	MAY 2017		05/01/2017	\$612.00		06/27/2017		R&R-Invoice	601MS802100010593 MAY 2017

AP755
 VENDOR PAYMENTS / FOR CLAIM DOCKET - 06/27/2017
 Report Title - AMOUNTS (DESCENDING) ALL TYPES
 Invoice Payments Under \$5,000 - Over \$500

VEN#	VENDOR-NAME	INVOICE	INV-DATE	AMOUNT	AUTHORIZATION	DUPLICATE	REF-NUMBER	PAYMENT-TYPE	REMARKS
61831	NAPA AUTO PARTS	JAC00037017822	01/05/2017	\$612.00				R&R-Invoice	MUNICIPAL GARAGE
	1 442206454	PUBLIC SAFETY - POLICE		\$610.71				R&R-Invoice	BILL BACK ITEMS
	1 451246316	JAC00037019533	05/22/2017	\$607.93				R&R-Invoice	MUNICIPAL GARAGE
71755	NATIONAL EXPRESS TRANSPORT CORP	91440975	05/10/2017	\$607.93				R&R-Invoice	MUNICIPAL GARAGE
	187 565106425	PLANNING & DEVELOPMENT		\$606.71				R&R-Invoice	MUNICIPAL GARAGE
61831	NAPA AUTO PARTS	JAC00037019533	05/22/2017	\$604.46				R&R-Invoice	MUNICIPAL GARAGE
	1 442406316	PUBLIC SAFETY - POLICE		\$604.46				R&R-Invoice	MUNICIPAL GARAGE
61831	NAPA AUTO PARTS	JAC00037019698	06/06/2017	\$603.77				R&R-Invoice	METER READING
	9 506106316	PUBLIC WORKS		\$603.77				R&R-Invoice	METER READING
42781	DIGITEC CORPORATION	99180	05/31/2017	\$600.65				R&R-Invoice	MUNICIPAL GARAGE
	187 565206514	PLANNING & DEVELOPMENT		\$600.65				R&R-Invoice	MUNICIPAL GARAGE
61831	NAPA AUTO PARTS	JAC00037019709	06/07/2017	\$8.06				R&R-Invoice	MUNICIPAL GARAGE
	1 442406316	PUBLIC SAFETY - POLICE		\$129.63				R&R-Invoice	MUNICIPAL GARAGE
	1 442406316	PUBLIC SAFETY - POLICE		\$130.87				R&R-Invoice	MUNICIPAL GARAGE
	1 442406316	PUBLIC SAFETY - POLICE		\$62.96				R&R-Invoice	MUNICIPAL GARAGE
	1 442406316	PUBLIC SAFETY - POLICE		\$269.13				R&R-Invoice	MUNICIPAL GARAGE
69239	MOMENT RICHARD DBA R & L	06152017A	06/15/2017	\$600.00				R&R-Invoice	CUTTING GRASS AND WEEDS: 0 COX (2016-1376) STREET/LOT BETWEEN 1638 & 1704 TRANSITION STRIP & PAINT
	1 442716447	PUBLIC SAFETY - POLICE		\$600.00				R&R-Invoice	CUTTING GRASS AND WEEDS: 0 COX (2016-1376) STREET/LOT BETWEEN 1638 & 1704 TRANSITION STRIP & PAINT
70362	BAN PROPERTIES LLC	040617A	04/06/2017	\$600.00				Regular-PO	TRANSITION STRIP & PAINT
	1 436206299	HUMAN & CULTURAL SERVICES		\$600.00				Regular-PO	TRANSITION STRIP & PAINT
	PJ 967 SUPPLIES FOR SMITH ROBERTSON MUSEUM			\$600.00				Regular-PO	TRANSITION STRIP & PAINT
	001	QUOTE---TRANSITION STRIP & PAINT		1,000	Received			Regular-PO	COMMERCIAL SERVICE
13160	JMC ENTERPRISES INC DBA	54086	06/08/2017	\$595.00				Regular-PO	COMMERCIAL SERVICE
	1 441706461	FIRE DEPARTMENT		\$595.00				Regular-PO	COMMERCIAL SERVICE
	PJ 1126 Over Head Door Repair Station 28 (Ladder Truck Slide)			\$595.00				Regular-PO	COMMERCIAL SERVICE
	001	Commercial Service		1,000	Received			Regular-PO	COMMERCIAL SERVICE
20225	ATMOS ENERGY	1276209258	06/27/2017	\$593.48				UTILITY-PAYM	UTILITY-PAYM
	31 521306453	PUBLIC WORKS		\$593.48				UTILITY-PAYM	UTILITY-PAYM
	0+3012762092	PUBLIC WORKS		\$593.46			0.1	UTILITY-PAYM	GAS
31592	STATE OF MS UMMC	H16018161600	02/02/2017	\$593.46				R&R-Invoice	SOSNOSKIE ROBERT (16J-187-WC) 00
	1 407926481	GENERAL GOVERNMENT		\$593.46				R&R-Invoice	SOSNOSKIE ROBERT (16J-187-WC) 00
61831	NAPA AUTO PARTS	JAC00037019579	05/25/2017	\$583.50				R&R-Invoice	MUNICIPAL GARAGE
	31 521406316	PUBLIC WORKS		\$583.50				R&R-Invoice	MUNICIPAL GARAGE
61831	NAPA AUTO PARTS	JAC00037019534	05/23/2017	\$571.91				R&R-Invoice	MUNICIPAL GARAGE
	1 442406316	PUBLIC SAFETY - POLICE		\$471.12				R&R-Invoice	MUNICIPAL GARAGE
	1 442406316	PUBLIC SAFETY - POLICE		\$45.26				R&R-Invoice	MUNICIPAL GARAGE
	1 442406316	PUBLIC SAFETY - POLICE		\$55.53				R&R-Invoice	MUNICIPAL GARAGE
70425	SMITH ENEKE WILLIAMS	061617	06/16/2017	\$571.60				R&R-Invoice	DEATH BENEFITS 13J52WC001
	1 407926766	GENERAL GOVERNMENT		\$571.60				R&R-Invoice	DEATH BENEFITS 13J52WC001
31592	STATE OF MS UMMC	H10241998000	04/11/2017	\$552.30				R&R-Invoice	ZEMARION MEERS(17J-59-WC) 00

AP755
 VENDOR PAYMENTS / FOR CLAIM DOCKET - 06/27/2017
 Report Title - AMOUNTS (DESCENDING) ALL TYPES
 Invoice Payments Under \$5,000 - Over \$500

VEN#	VENDOR-NAME	INVOICE	INV-DATE	AMOUNT	AUTHORIZATION	DUE-DATE	REF-NUMBER	PAYMENT-TYPE	REMARKS
40789	CINTAS CORPORATION	GENERAL GOVERNMENT	04/18/2017	\$552.30		06/27/2017		R&R-Invoice	04/11/17 210327559 210330616 210333647
04402	CONSOLIDATED PIPE & SUPPLY CO	PUBLIC SAFETY - POLICE	12/02/2016	\$551.64		06/27/2017		R&R-Invoice	210336690 210339724 21034847
63860	ROWLAND G GARRETT	PUBLIC WORKS	2017-608	\$549.05		06/27/2017		R&R-Invoice	PAYING FOR EMERGENCY PARTS DUE TO A WATER MAIN BREAK
	LJ 1754 Custodial Services	PUBLIC WORKS	2017-608	\$550.00		06/27/2017		Limited-PO	PRIDE SUPER CLEANER
63860	ROWLAND G GARRETT	PRIDE SUPER CLEANER	2017-613	\$550.00		06/27/2017		Limited-PO	PRIDE SUPER CLEANER
	LJ 1802 Thalia Mara	PUBLIC WORKS	2017-613	\$550.00		06/27/2017		Limited-PO	PRIDE SUPER CLEANER
B1995	JOHNSON BETTIE RUTH	Pride Super Cleaner	06/01/2017	\$550.00	Invoiced	06/27/2017		R&R-Invoice	FULL & COMPLETE SETTLEMENT
42781	DIGITEC CORPORATION	GENERAL GOVERNMENT	05/30/2017	\$548.26		06/27/2017		R&R-Invoice	COPIER RENTAL
60427	MIPCO IMPRESSION PRODUCTS INC	ADMINISTRATION	06/01/2017	\$546.94		06/27/2017		R&R-Invoice	COPIER RENTAL
03660	CARLS SHEET METAL SHOP	PLANNING & DEVELOPMENT	05/11/2017	\$545.16		06/27/2017		Regular-PO	BRACKETS
	PJ 1108 BRACKETS AND POSTS	HUMAN & CULTURAL SERVICES	05/11/2017	\$545.16		06/27/2017		Regular-PO	BRACKETS
61831	NAPA AUTO PARTS	QUOTE--BRACKETS 3/8" X 4" X 36	05/22/2017	\$543.18	Received	\$335.16		R&R-Invoice	MUNICIPAL GARAGE
		POST 1" PIPE X 36" TALL	05/22/2017	\$52.42	Received	\$210.00		R&R-Invoice	MUNICIPAL GARAGE
40432	AIRGAS USA INC	PUBLIC SAFETY - POLICE	04/01/2017	\$534.80		06/27/2017		R&R-Invoice	CYLINDER RENTAL
66692	CAPITOL STAFFING INC	PUBLIC SAFETY - POLICE	06/07/2017	\$510.00		06/27/2017		R&R-Invoice	TEMP CLARA HARRIS
20377	ENTERGY	GENERAL GOVERNMENT	06/27/2017	\$502.91		06/27/2017	18624445	R&R-Invoice	UTILITY-PAYM
		FIRE DEPARTMENT	06/27/2017	\$502.91		06/19/2017	0.1	R&R-Invoice	ELECTRIC LIGHT AND POWER

** Payments Under \$5,000 - Over \$500 * \$282,857.53

AP755 VENDOR PAYMENTS / FOR CLAIM DOCKET - 06/27/2017
 Report Title - AMOUNTS (DESCENDING) ALL TYPES
 Invoice Payments Under \$500

VEN#	VENDOR-NAME	INVOICE	INV-DATE	AMOUNT	AUTHORIZATION	DUE-DATE	REF-NUMBER	PAYMENT-TYPE	REMARKS
71633	STATE OF MISSISSIPPI	UST00020490	06/08/2017	\$500.00		06/27/2017		R&R-Invoice	ANNUAL TANK FEE
	31 522406419	PUBLIC WORKS		\$125.00					
	31 522306419	PUBLIC WORKS		\$125.00					
	1 493006419	GENERAL GOVERNMENT		\$125.00					
	31 522356419	PUBLIC WORKS		\$125.00					
63860	ROWLAND G GARRETT	2017-449	05/17/2017	\$498.00		06/27/2017		Limited-PO	JR JUMBO TISSUE
	1 457006213	PUBLIC WORKS		\$498.00					
	LJ 1615 Custodial			\$498.00					
	001	Jr. Jumbo Tissue		20.000	Invoiced				
61831	NAPA AUTO PARTS	JAC00037019607	05/31/2017	\$496.88		05/31/2017		R&R-Invoice	MUNICIPAL GARAGE
	1 442406316	PUBLIC SAFETY - POLICE		\$496.88					
15580	SOUND & COMMUNICATIONS INC	1041	10/01/2016	\$495.00		06/27/2017		Regular-PO	DIGITAL VIDEO CASSETTE 60 MIN DIGITAL VIDEO CASSETTE 60 MIN
	300 443466232	GENERAL GOVERNMENT		\$495.00					
	PI 1153 Tapes for PEG Production			\$495.00					
	001	QUOTE: Fuji DVC mini-dv Digita		150.000	Received				
20377	ENTERGY	16488975\	06/27/2017	\$493.47		06/27/2017	16489171	UTILITY-PAYM	
	1 441706451	FIRE DEPARTMENT		\$493.47					
	0+16488975	FIRE DEPARTMENT		\$492.50		06/19/2017	0.1	\$493.47	ELECTRIC LIGHT AND POWER FOR EMERGENCY WELDING REPAIR LINE @ THE ZEON PLANT AT O B ON THE STEEL COMPRESSED AIR CURTIS WTP
12960	NOVELLY MACHINE WORKS INC	83182	06/06/2017	\$492.50		06/27/2017		R&R-Invoice	
	31 521356419	PUBLIC WORKS		\$492.50					
61831	NAPA AUTO PARTS	JAC00037019507	05/22/2017	\$492.11		05/22/2017		R&R-Invoice	MUNICIPAL GARAGE
	31 521406316	PUBLIC WORKS		\$4.68					
	31 521406316	PUBLIC WORKS		\$4.71					
	31 521406316	PUBLIC WORKS		\$458.79					
	31 521406316	PUBLIC WORKS		\$23.93					
46403	PETTY CASH-FINANCE/WKS COMP	4138	06/13/2017	\$477.82		06/27/2017		R&R-Invoice	TEMPORARY TOTAL DISABILITY BENEFITS - GARRY ARTHUR
	1 407926766	GENERAL GOVERNMENT		\$477.82					
20377	ENTERGY	16548422\	06/27/2017	\$471.60		06/27/2017	16571655	UTILITY-PAYM	
	1 441706451	FIRE DEPARTMENT		\$471.60					
	0+16548422	FIRE DEPARTMENT		\$471.60		06/19/2017	0.1	\$471.60	ELECTRIC LIGHT AND POWER COPIER RENTAL
30401	XEROX CORPORATION	089290291	06/01/2017	\$470.31		06/27/2017		R&R-Invoice	COPIER RENTAL
	1 461106514	PUBLIC WORKS		\$470.31					
13160	JMC ENTERPRISES INC DBA	54024	06/05/2017	\$470.00		06/27/2017		Regular-PO	COMMERCIAL SERVICE REMOVED REMOVED OPERATOR ARM AND TORN BENT ANGLE ON TOP SECTION CENTER STYLE ADJUSTED TENSION
	1 441706461	FIRE DEPARTMENT		\$470.00					
	PJ 984 Station 6 Overhead Door Repair			\$470.00					
	001	QUOTE--remove bent angle on to		1.000	Received				
30401	XEROX CORPORATION	089290290	06/01/2017	\$467.12		06/27/2017		R&R-Invoice	COPIER RENTAL
	1 450106514	PUBLIC WORKS		\$467.12					

AP755
 VENDOR PAYMENTS / FOR CLAIM DOCKET - 06/27/2017
 Report Title - AMOUNTS (DESCENDING) ALL TYPES
 Invoice Payments Under \$500

VEN#	VENDOR-NAME	INVOICE	INV-DATE	AMOUNT	AUTHORIZATION	DUE-DATE	REF-NUMBER	PAYMENT-TYPE	REMARKS
69239	MOMENT RICHARD DBA R & L	2016-1483	06/15/2017	\$464.00	Received	06/27/2017		R&R-Invoice	CUTTING GRASS AND WEEDS 1959
	1 442716447	PUBLIC SAFETY - POLICE		\$464.00				R&R-Invoice	SMALLWOOD STREET(2016-1483)
70072	OFFICE DEPOT #414	925974171001	05/08/2017	\$445.98		06/27/2017		Regular-PO	TONER HP 312A BLACK
	1 451106218	PUBLIC WORKS		\$445.98					HP 312A 3-PACK C/Y/M LJ TN
	PJ 823 Ink Toner			\$445.98					
	001	Black Toner Cartridge		1.000	Received	\$96.99			
	002	Toner Cartridge (Cyan/Magenta/		1.000	Received	\$348.99			
61831	NAPA AUTO PARTS	JAC00037019681	06/05/2017	\$444.80		06/05/2017		R&R-Invoice	MUNICIPAL GARAGE
	1 442406316	PUBLIC SAFETY - POLICE		\$444.80				R&R-Invoice	
42781	DIGITEC CORPORATION	99176	05/31/2017	\$438.64		06/27/2017		R&R-Invoice	COPIER RENTAL
	187 565206514	PLANNING & DEVELOPMENT		\$438.64				R&R-Invoice	
61831	NAPA AUTO PARTS	JAC00037019731	06/08/2017	\$435.38		06/08/2017		R&R-Invoice	MUNICIPAL GARAGE
	1 442406316	PUBLIC SAFETY - POLICE		\$118.90				R&R-Invoice	
	1 442406316	PUBLIC SAFETY - POLICE		\$7.17				R&R-Invoice	
	1 442406316	PUBLIC SAFETY - POLICE		\$87.99				R&R-Invoice	
	1 442406316	PUBLIC SAFETY - POLICE		\$87.99				R&R-Invoice	
	1 442406316	PUBLIC SAFETY - POLICE		\$133.33				R&R-Invoice	
46371	STANTON BODY SHOP	19362	06/01/2017	\$425.00		06/27/2017		R&R-Invoice	19362 19363 19364 19367 19371
	1 442206465	PUBLIC SAFETY - POLICE		\$425.00				R&R-Invoice	WRECKER SERVICE
B2001	SHOULDERS JERRY	10835	06/07/2017	\$425.00		06/27/2017		R&R-Invoice	FULL & COMPLETE SETTLEMENT
	18 518206722	GENERAL GOVERNMENT		\$425.00				R&R-Invoice	
32031	RICOH USA INC	98914943	06/06/2017	\$410.70		06/27/2017		R&R-Invoice	COPIER RENTAL
	1 441106514	FIRE DEPARTMENT		\$410.70				R&R-Invoice	
06371	PETTY CASH-FINANCE/TRAVEL	13409	06/12/2017	\$408.00		06/27/2017		R&R-Invoice	HOTEL-MARY MANOGIN
	85 809206473	PLANNING & DEVELOPMENT		\$408.00				R&R-Invoice	TUNICA, MS - CONFERENCE
06371	PETTY CASH-FINANCE/TRAVEL	13409A	06/12/2017	\$408.00		06/27/2017		R&R-Invoice	HOTEL-MARY MANOGIN
	120 901106473	PLANNING & DEVELOPMENT		\$408.00				R&R-Invoice	TUNIC, MS - CONFERENCE
65039	SOUTHERN DIAGNOSTIC IMAGING	153556A	04/06/2017	\$400.05		06/27/2017		R&R-Invoice	TILLER TERRANCE(17J-27-WC)00
	1 407926481	GENERAL GOVERNMENT		\$400.05				R&R-Invoice	
72062	JAZZ BEAUTIFUL LLC	06102017	06/10/2017	\$400.00		06/27/2017		R&R-Invoice	SAX AND PIANO ARRANGEMENT FOR
	1 436006419	HUMAN & CULTURAL SERVICES		\$400.00				R&R-Invoice	"WOOLMORTH'S SIT-IN-FIR CHANGE
61831	NAPA AUTO PARTS	JAC00037019695	06/06/2017	\$396.25		06/06/2017		R&R-Invoice	MUNICIPAL GARAGE
	1 442406316	PUBLIC SAFETY - POLICE		\$7.17				R&R-Invoice	
	1 442406316	PUBLIC SAFETY - POLICE		\$87.99				R&R-Invoice	
	1 442406316	PUBLIC SAFETY - POLICE		\$61.43				R&R-Invoice	
	1 442406316	PUBLIC SAFETY - POLICE		\$60.38				R&R-Invoice	
	1 442406316	PUBLIC SAFETY - POLICE		\$60.38				R&R-Invoice	
	1 442406316	PUBLIC SAFETY - POLICE		\$118.90				R&R-Invoice	
61831	NAPA AUTO PARTS	JAC00037019614	06/01/2017	\$395.08		06/01/2017		R&R-Invoice	MUNICIPAL GARAGE
	31 521406316	PUBLIC WORKS		\$395.08				R&R-Invoice	
31592	STATE OF MS UMC	H160177573002	12/21/2016	\$391.33		06/27/2017		R&R-Invoice	SOSNOSKIE ROBERT(16J-187-WC)00
	1 407926481	GENERAL GOVERNMENT		\$391.33				R&R-Invoice	122116

VENDOR PAYMENTS / FOR CLAIM DOCKET - 06/27/2017
 Report Title - AMOUNTS (DESCENDING) ALL TYPES
 Invoice Payments Under \$500

VEN#	VENDOR-NAME	INVOICE	INV-DATE	AMOUNT	AUTHORIZATION	DUE-DATE	REF-NUMBER	PAYMENT-TYPE	REMARKS
48375	POCKETT MACHINERY COMPANY	P00C9368771	05/30/2017	\$391.81		06/27/2017		Limited-PO	SEAL IN BULK HOSE CM-GUARD H
	9 506106316	PUBLIC WORKS		\$391.81					COUPLING AS PARTS LABOR SEAL COUPLING AS MISC CHARGES
68976	STONERIVER	44337544	04/24/2017	\$390.80		06/27/2017		R&R-Invoice	SAM SANDIFER
	1 407926212	GENERAL GOVERNMENT		\$390.80					
42781	DIGITEC CORPORATION	98223	04/20/2017	\$390.00		06/27/2017		R&R-Invoice	COPIER RENTAL
	1 414106514	ADMINISTRATION		\$390.00					
42781	DIGITEC CORPORATION	98227	04/20/2017	\$390.00		06/27/2017		R&R-Invoice	COPIER RENTAL
	1 414106514	ADMINISTRATION		\$390.00					
43122	WASTE MANAGEMENT OF MS INC	2815057-0078-7	06/01/2017	\$386.75		06/27/2017		R&R-Invoice	2815057-0078-7
	9 455106426	PUBLIC WORKS		\$386.75					DISPOSAL CONTRACT
06371	PETTY CASH-FINANCE/TRAVEL	13208	06/12/2017	\$383.63		06/27/2017		R&R-Invoice	HOTEL-TONY YARBER
	1 401926473	GENERAL GOVERNMENT		\$383.63					KANSAS CITY, MO
61831	NAPA AUTO PARTS	JAC00037019733	06/08/2017	\$383.26		06/08/2017		R&R-Invoice	MUNICIPAL GARAGE
	31 521306316	PUBLIC WORKS		\$383.26					
	31 521306316	PUBLIC WORKS		\$55.53					
	31 521306316	PUBLIC WORKS		\$26.53					
71890	CANON FINANCIAL SERVICES	17446784	06/12/2017	\$383.63		06/27/2017		R&R-Invoice	COPIER RENTAL
	1 411106514	ADMINISTRATION		\$383.63					
B1964	ROSS LEKESHA ,	017052200	05/22/2017	\$382.66		06/27/2017		R&R-Invoice	WATER REFUND ACC 77910000
	30 2108	Liabilities		\$382.66					
69953	INJURED WORKERS PHARMACY LLC	3247345	04/19/2017	\$381.74		06/27/2017		R&R-Invoice	DEXTER SIMMONS
	1 407926212	GENERAL GOVERNMENT		\$381.74					
20377	ENTERGY	18291369\	06/27/2017	\$376.61		06/27/2017	18292342	UTILITY-PAYM	
	1 441706451	FIRE DEPARTMENT		\$376.61					
60427	MIPCO IMPRESSION PRODUCTS INC	131809	06/01/2017	\$376.97		06/19/2017	0.1	\$376.61	ELECTRIC LIGHT AND POWER
	1 407906514	GENERAL GOVERNMENT		\$376.97				R&R-Invoice	COPIER RENTAL
20377	ENTERGY	18624445\	06/27/2017	\$375.61		06/27/2017	18624668	UTILITY-PAYM	
	1 491006451	HUMAN & CULTURAL SERVICES		\$375.61					
71210	VICTORY A M E ZION CHURCH	060917	06/09/2017	\$375.00		06/19/2017	0.1	\$375.61	ELECTRIC LIGHT AND POWER
	1 402206419	GENERAL GOVERNMENT		\$375.00				R&R-Invoice	USE FACILITY FOR ELECTIONS
72625	DENT AIR CONDITIONING CO	264728	01/31/2017	\$375.00		06/27/2017		R&R-Invoice	CAMERA SEMER LINE SERVICE AT
	32 522907B05009016485	PUBLIC WORKS		\$375.00					1132 ARBOR VISTA BLVD
20377	ENTERGY	19832005\	06/27/2017	\$365.97		06/27/2017	19832187	UTILITY-PAYM	
	1 441706451	FIRE DEPARTMENT		\$365.97					
31592	STATE OF MS UMMC	H10181699202	10/01/2016	\$365.70		06/19/2017	0.1	\$365.97	ELECTRIC LIGHT AND POWER
	0+19832005	FIRE DEPARTMENT		\$365.70				R&R-Invoice	WILLIAMS TERRY(16J-59-WC)00

AP755 VENDOR PAYMENTS / FOR CLAIM DOCKET - 06/27/2017
 Report Title - AMOUNTS (DESCENDING) ALL TYPES
 Invoice Payments Under \$500

VEN#	VENDOR-NAME	INVOICE	INV-DATE	AMOUNT	AUTHORIZATION	DUE-DATE	REF-NUMBER	PAYMENT-TYPE	REMARKS
61831	NAPA AUTO PARTS	GENERAL GOVERNMENT	06/05/2017	\$365.70		06/05/2017		R&R-Invoice	03192016
	31 521406316	PUBLIC WORKS		\$360.48				R&R-Invoice	MUNICIPAL GARAGE
61831	NAPA AUTO PARTS	JAC00037019639	06/02/2017	\$357.04		06/02/2017		R&R-Invoice	MUNICIPAL GARAGE
	1 442406316	PUBLIC SAFETY - POLICE		\$333.82					
	1 442406316	PUBLIC SAFETY - POLICE		\$6.54					
	1 442406316	PUBLIC SAFETY - POLICE		\$6.64					
68267	UNIVERSITY PHYSICIANS	PUBLIC SAFETY - POLICE	03/08/2017	\$10.04					
	1 407926481	GENERAL GOVERNMENT		\$356.25		06/27/2017		R&R-Invoice	SMITH MIRON B(17J-33-WC)00
68267	UNIVERSITY PHYSICIANS	GENERAL GOVERNMENT	03/08/2017	\$356.25		06/27/2017		R&R-Invoice	030817
	1 407926481	GENERAL GOVERNMENT		\$356.25				R&R-Invoice	SMITH MIRON B(17J-33-WC)00
20377	ENTERGY	GENERAL GOVERNMENT	06/27/2017	\$355.83		06/27/2017	16745614	UTILITY-PAYM	030817
	1 441706451	FIRE DEPARTMENT		\$355.83					
40789	CINTAS CORPORATION	FIRE DEPARTMENT	06/06/2017	\$351.51		06/19/2017	0.1	\$355.83	ELECTRIC LIGHT AND POWER
	31 521406516	PUBLIC WORKS		\$351.51		06/27/2017		R&R-Invoice	UNIFORM RENTAL
06371	PETTY CASH-FINANCE/TRAVEL	13423	06/12/2017	\$350.00		06/27/2017		R&R-Invoice	STATE FIRE ACADEMY COURSE
	10 509006443	FIRE DEPARTMENT		\$350.00				R&R-Invoice	JIMMY EPPS & GEORGE HORN
68571	MAYWOOD FOODS INC	742140	06/06/2017	\$347.52		06/27/2017		R&R-Invoice	FOOD FOR EARLY CHILDHOOD CENTER
	81 598516227	HUMAN & CULTURAL SERVICES		\$347.52					
61831	NAPA AUTO PARTS	JAC00037019603	05/31/2017	\$339.08		05/31/2017		R&R-Invoice	MUNICIPAL GARAGE
	1 442406316	PUBLIC SAFETY - POLICE		\$123.03					
	1 442406316	PUBLIC SAFETY - POLICE		\$216.05					
61831	NAPA AUTO PARTS	JAC00037019665	06/05/2017	\$339.08		06/05/2017		R&R-Invoice	MUNICIPAL GARAGE
	1 442406316	PUBLIC SAFETY - POLICE		\$216.05					
	1 442406316	PUBLIC SAFETY - POLICE		\$123.03					
20377	ENTERGY	18257329\	06/27/2017	\$338.79		06/27/2017	18258046	UTILITY-PAYM	
	1 441706451	FIRE DEPARTMENT		\$338.79					
61831	NAPA AUTO PARTS	JAC00037019491	05/19/2017	\$337.10		06/19/2017	0.1	\$338.79	ELECTRIC LIGHT AND POWER
	1 442406316	PUBLIC SAFETY - POLICE		\$235.56		05/19/2017		R&R-Invoice	MUNICIPAL GARAGE
	1 442406316	PUBLIC SAFETY - POLICE		\$45.26					
	1 442406316	PUBLIC SAFETY - POLICE		\$55.53					
	1 442406316	PUBLIC SAFETY - POLICE		\$75					
71485	ANESTHESIA SERVICES ASSOCIATES	2966861	04/03/2017	\$336.49		06/27/2017		R&R-Invoice	WALKER VELISA F(13J-67-WC)001
	1 407926481	GENERAL GOVERNMENT		\$336.49					040317
61831	NAPA AUTO PARTS	JAC00037019501	05/19/2017	\$334.41		05/20/2017		R&R-Invoice	MUNICIPAL GARAGE
	1 443106316	ADMINISTRATION		\$26.65					
	1 443106316	ADMINISTRATION		\$178.80					
	1 443106316	ADMINISTRATION		\$3.90					
	1 443106316	ADMINISTRATION		\$102.44					

AP755
 VENDOR PAYMENTS / FOR CLAIM DOCKET - 06/27/2017
 Report Title - AMOUNTS (DESCENDING) ALL TYPES
 Invoice Payments Under \$500

VEN#	VENDOR-NAME	INVOICE	ADMINISTRATION	INV-DATE	AMOUNT	AUTHORIZATION	DUE-DATE	REF-NUMBER	PAYMENT-TYPE	REMARKS
61831	NAPA AUTO PARTS	1 443106316	JAC00037019523	05/22/2017	\$333.34		05/22/2017		R&R-Invoice	MUNICIPAL GARAGE
		31 521406316	PUBLIC WORKS		\$333.34					
65516	GRAY DANIELS AUTO FAMILY	600377		05/03/2017	\$329.95		06/27/2017		Limited-PO	REPAIR A/C
		1 451256316	PUBLIC WORKS		\$329.95					
	LJ 1532 TK 678 REPAIR A/C									
		001	INVOICE 600377 TK 678 REPAIR		1.000	Received	\$329.95			
61831	NAPA AUTO PARTS	JAC00037019616		06/01/2017	\$325.28		06/01/2017		R&R-Invoice	MUNICIPAL GARAGE
		1 442406316	PUBLIC SAFETY - POLICE		\$31.68					
		1 442406316	PUBLIC SAFETY - POLICE		\$103.18					
		1 442406316	PUBLIC SAFETY - POLICE		\$175.41					
		1 442406316	PUBLIC SAFETY - POLICE		\$6.95					
		1 442406316	PUBLIC SAFETY - POLICE		\$8.06					
69953	INJURED WORKERS PHARMACY LLC	3247263	GENERAL GOVERNMENT	04/19/2017	\$324.57		06/27/2017		R&R-Invoice	DEXTER SIMMONS
		1 407926212	GENERAL GOVERNMENT		\$324.57					
61831	NAPA AUTO PARTS	JAC00037019613		06/01/2017	\$323.58		06/01/2017		R&R-Invoice	MUNICIPAL GARAGE
		1 442406316	PUBLIC SAFETY - POLICE		\$222.40					
		1 442406316	PUBLIC SAFETY - POLICE		\$52.42					
		1 442406316	PUBLIC SAFETY - POLICE		\$41.36					
		1 442406316	PUBLIC SAFETY - POLICE		\$6.90					
		1 442406316	PUBLIC SAFETY - POLICE		\$5.50					
62567	RICHARDSON ATHLETICS LLC	24900	PARKS & RECREATION	04/20/2017	\$316.98		06/27/2017		Regular-PO	ITEM #5555XXXX
		5 501266221	PARKS & RECREATION		\$316.98					GAME SERIOUS BREAKWAY GOAL
		PJ 934 Basketball Rim Replacement forKurts Gym	Item #5555XXXX Game Serious Br		\$316.98					
		001	SHIPPING CHARGE		2.000	Received	\$291.98			
		002	SHIPPING CHARGE		1.000	Received	\$25.00			
07260	GRAYBAR ELECTRIC CO INC	991064873/989279605		04/26/2017	\$313.57		06/27/2017		R&R-Invoice	A FOOT SPOOL WIRE FOR WIRING
		31 521356464	PUBLIC WORKS		\$313.57					
61831	NAPA AUTO PARTS	JAC00037019641		06/02/2017	\$314.00		06/02/2017		R&R-Invoice	MUNICIPAL GARAGE
		31 521206316	PUBLIC WORKS		\$314.00					
66021	COMCAST CABLE	09577 352143-01-1/052517		05/25/2017	\$313.80		06/27/2017		R&R-Invoice	09577 352143-01-1 CABLE SERVICES
		1 442106419	PUBLIC SAFETY - POLICE		\$313.80					
69953	INJURED WORKERS PHARMACY LLC	3094566/042417	GENERAL GOVERNMENT	04/24/2017	\$313.27		06/27/2017		R&R-Invoice	DEXTER SIMMONS 04/24/17
		1 407926212	GENERAL GOVERNMENT		\$313.27					
61831	NAPA AUTO PARTS	JAC00037019567		05/25/2017	\$312.67		05/25/2017		R&R-Invoice	MUNICIPAL GARAGE
		31 521406316	PUBLIC WORKS		\$277.67					
		31 521406316	PUBLIC WORKS		\$35.00					
20377	ENTERGY	19831585\		06/27/2017	\$311.13		06/27/2017	19831767	UTILITY-PAYM	
		1 442216451	PUBLIC SAFETY - POLICE		\$311.13					
		0+19831585	PUBLIC SAFETY - POLICE		\$311.13		06/19/2017	0.1		ELECTRIC LIGHT AND POWER
72153	COMPREHENSIVE WELLNESS PHARMAC	041017	GENERAL GOVERNMENT	04/10/2017	\$308.76		06/27/2017		R&R-Invoice	VELISA WALKER 04/10/17
		1 407926212	GENERAL GOVERNMENT		\$308.76					

AP755
 VENDOR PAYMENTS / FOR CLAIM DOCKET - 06/27/2017
 Report Title - AMOUNTS (DESCENDING) ALL TYPES
 Invoice Payments Under \$500

VEN#	VENDOR-NAME	INVOICE	INV-DATE	AMOUNT	AUTHORIZATION	DUE-DATE	REF-NUMBER	PAYMENT-TYPE	REMARKS
61831	NAPA AUTO PARTS	JAC00037019609	06/01/2017	\$303.28		06/01/2017		R&R-Invoice	MUNICIPAL GARAGE
		1 442406316		\$7.20					
		1 442406316		\$28.00					
		1 442406316		\$22.72					
		1 442406316		\$4.07					
		1 442406316		\$241.29					
63560	NOTALL LEWIS	062017	06/20/2017	\$303.88		06/27/2017		R&R-Invoice	MEDICAL MILEAGE REIMBURSEMENT
		1 407926481		\$303.88					
61831	NAPA AUTO PARTS	JAC00037019671	06/05/2017	\$301.90		06/05/2017		R&R-Invoice	MUNICIPAL GARAGE
		1 442406316		\$6.28					
		1 442406316		\$55.53					
		1 442406316		\$2.30					
		1 442406316		\$235.56					
		1 442406316		\$2.23					
06371	PETTY CASH-FINANCE/TRAVEL	13443	06/12/2017	\$300.00		06/27/2017		R&R-Invoice	REGISTRATION-MARY MANOGIN TUNICA, MS - CONFERENCE
		120 901106443		\$300.00					
71243	WALKER RONALD E PH D	06012017	06/01/2017	\$300.00		06/27/2017		R&R-Invoice	CIVIL SERVICE COMMISSIONER FEE FOR JUNE 2017
		1 413006122		\$300.00					
71244	STOKES ESTER W	06012017	06/01/2017	\$300.00		06/27/2017		R&R-Invoice	CIVIL SERVICE COMMISSIONER FEE FOR JUNE 2017
		1 413006122		\$300.00					
71370	LA NOTICIA MS	121165	05/11/2017	\$300.00		06/27/2017		R&R-Invoice	PUBLIC NOTICE CITY WILL CONDUCT PUBLIC HEARING AND THE DEVELOPMENT OF ITS 2017 LUNCH FOR AMERICORP MEMBERS
		85 809106444		\$300.00					
72610	SHEKINAH GLORY BAPTIST CHURCH	061417	06/14/2017	\$300.00		06/27/2017		R&R-Invoice	APPLICATION WORKSHOP REGARDING CONDUCT PUBLIC HEARING AND THE DEVELOPMENT OF ITS 2017 LUNCH FOR AMERICORP MEMBERS
		134 438106476		\$300.00					
81997	BROOKS ALDEN	11054	06/01/2017	\$300.00		06/27/2017		R&R-Invoice	FULL & COMPLETE SETTLEMENT
		18 518206722		\$300.00					
61831	NAPA AUTO PARTS	JAC00037019720	06/07/2017	\$296.56		06/07/2017		R&R-Invoice	MUNICIPAL GARAGE
		31 521356316		\$43.78					
		31 521356316		\$11.37					
		31 521356316		\$10.47					
		31 521356316		\$230.94					
59466	W W GRAINGER, INC	940707990	04/05/2017	\$295.43		06/27/2017		Limited-PO	SUMP PUMP
		1 419106317		\$295.43					
		LJ 1280 Thalia Mara		\$295.43					
		001		1,000	Invoiced				
10860	MEL LUNA SAW CO	84742	05/19/2017	\$290.00		06/27/2017		Regular-PO	STIHL WEED EATER
		31 521356865		\$290.00					
		PJ 1086 REPLACEMENT FOR A NEW STIHL WEED EATER		\$290.00					
		001		1,000	Received				
61831	NAPA AUTO PARTS	JAC00037019666	06/05/2017	\$287.70		06/05/2017		R&R-Invoice	MUNICIPAL GARAGE

AP755
 VENDOR PAYMENTS / FOR CLAIM DOCKET - 06/27/2017
 Report Title - AMOUNTS (DESCENDING) ALL TYPES
 Invoice Payments Under \$500

VEN#	VENDOR-NAME	INVOICE	INV-DATE	AMOUNT	AUTHORIZATION	DUE-DATE	REF-NUMBER	PAYMENT-TYPE	REMARKS
31592	STATE OF MS UMMC	H10173217704	10/01/2016	\$285.01	GENERAL GOVERNMENT	06/27/2017		R&R-Invoice	DUNAGAN PATRICE(16J-204WC)00 012716
61831	NAPA AUTO PARTS	JAC000037019705	06/07/2017	\$285.42	PUBLIC SAFETY - POLICE	06/07/2017		R&R-Invoice	MUNICIPAL GARAGE
1442406316	1 442406316	PUBLIC SAFETY - POLICE		\$45.26					
1442406316	1 442406316	PUBLIC SAFETY - POLICE		\$4.60					
1442406316	1 442406316	PUBLIC SAFETY - POLICE		\$235.56					
71759	DRAYER PHYSICAL THERAPY LLC	MS0334365/050117	05/01/2017	\$282.96	GENERAL GOVERNMENT	06/27/2017		R&R-Invoice	ALLEN AARON(17J-09-WC)00 050117
11759	DRAYER PHYSICAL THERAPY LLC	MS0334365/050317	05/03/2017	\$282.96	GENERAL GOVERNMENT	06/27/2017		R&R-Invoice	ALLEN AARON(17J-09-WC)00 050317
1407926481	1 407926481	GENERAL GOVERNMENT		\$282.96				R&R-Invoice	ALLEN AARON(17J-09-WC)00 050517
71759	DRAYER PHYSICAL THERAPY LLC	MS0334365/050517	05/05/2017	\$282.96	GENERAL GOVERNMENT	06/27/2017		R&R-Invoice	ALLEN AARON(17J-09-WC)00 050517
1407926481	1 407926481	GENERAL GOVERNMENT		\$282.96				R&R-Invoice	TILLER TERRANCE(17J-27-WC)00 031117
31592	STATE OF MS UMMC	H10237555700	03/11/2017	\$279.11	GENERAL GOVERNMENT	06/27/2017		R&R-Invoice	TILLER TERRANCE(17J-27-WC)00 031117
1407926481	1 407926481	GENERAL GOVERNMENT		\$279.11				R&R-Invoice	JACQUEZ REDMOND 03/19/17
31592	STATE OF MS UMMC	H10238521300	03/19/2017	\$279.11	GENERAL GOVERNMENT	06/27/2017		R&R-Invoice	JACQUEZ REDMOND 03/19/17
1407926481	1 407926481	GENERAL GOVERNMENT		\$279.11				R&R-Invoice	SMITH MIRON B(17J-33-WC)00 030817
68267	UNIVERSITY PHYSICIANS	164730700	03/08/2017	\$278.13	GENERAL GOVERNMENT	06/27/2017		R&R-Invoice	SMITH MIRON B(17J-33-WC)00 030817
1407926481	1 407926481	GENERAL GOVERNMENT		\$278.13				R&R-Invoice	UNIFORM RENTAL
40789	CINTAS CORPORATION	210345862	05/30/2017	\$277.17	PARKS & RECREATION	06/27/2017		R&R-Invoice	UNIFORM RENTAL
504106516	5 504106516	PARKS & RECREATION		\$277.17				R&R-Invoice	PODS RENTAL
65787	PREMIER PORTABLE STORAGE INC	2023000009992	05/10/2017	\$278.00	PUBLIC WORKS	06/27/2017		R&R-Invoice	PODS RENTAL
223453106512	223 453106512	PUBLIC WORKS		\$278.00				R&R-Invoice	DEXTER SIMMONS 04/16/17
69953	INJURED WORKERS PHARMACY LLC	31947222/041617	04/16/2017	\$277.70	GENERAL GOVERNMENT	06/27/2017		R&R-Invoice	DEXTER SIMMONS 04/16/17
1407926212	1 407926212	GENERAL GOVERNMENT		\$277.70				R&R-Invoice	HOTEL-TONY YARBER KANSAS CITY, MO
06371	PETTY CASH-FINANCE/TRAVEL	13193	06/12/2017	\$276.93	GENERAL GOVERNMENT	06/27/2017		R&R-Invoice	HOTEL-TONY YARBER KANSAS CITY, MO
1401926473	1 401926473	GENERAL GOVERNMENT		\$276.93				R&R-Invoice	UNIFORM RENTAL
40789	CINTAS CORPORATION	210348873	06/06/2017	\$274.05	PARKS & RECREATION	06/27/2017		R&R-Invoice	UNIFORM RENTAL
504106516	5 504106516	PARKS & RECREATION		\$274.05				R&R-Invoice	TILLER TERRANCE(17J-27-WC)00 042117
67801	GENESIS PT & REHAB SERVICES LL	1544075A	04/21/2017	\$264.06	GENERAL GOVERNMENT	06/27/2017		R&R-Invoice	TILLER TERRANCE(17J-27-WC)00 042117
1407926481	1 407926481	GENERAL GOVERNMENT		\$264.06				R&R-Invoice	109-9023 BELT 1-643052 RLM 110
10860	MEL LUNA SAW CO	84865	06/13/2017	\$261.36	PARKS & RECREATION	06/27/2017		R&R-Invoice	109-9023 BELT 1-643052 RLM 110
504106316	5 504106316	PARKS & RECREATION		\$122.36				R&R-Invoice	
504106316	5 504106316	PARKS & RECREATION		\$139.00				R&R-Invoice	
1822	REPAIR EQUIPMENT			\$261.36				R&R-Invoice	

AP755
 VENDOR PAYMENTS / FOR CLAIM DOCKET - 06/27/2017
 Report Title - AMOUNTS (DESCENDING) ALL TYPES
 Invoice Payments Under \$500

VEN#	VENDOR-NAME	INVOICE	INV-DATE	AMOUNT	AUTHORIZATION	DUE-DATE	REF-NUMBER	PAYMENT-TYPE	REMARKS
61831	NAPA AUTO PARTS	31 522206316	05/19/2017	\$257.00	Received	05/19/2017		R&R-Invoice	MUNICIPAL GARAGE
		31 522206316		\$35.03	Received				
		31 522206316		\$19.21	Received				
		31 522206316		\$32.95	Received				
		31 522206316		\$54.32	Received				
		31 522206316		\$43.21	Received				
		31 522206316		\$43.21-	Received				
		31 522206316		\$4.26	Received				
66021	COMCAST CABLE	09577779087-016	06/07/2017	\$254.28	Received	06/27/2017		R&R-Invoice	CABLE SERVICES
		1 442106419		\$254.28	Received				09577 779087-01-6
20377	ENTERGY	18256867\	06/27/2017	\$252.60	Received	06/27/2017	18257329	UTILITY-PAYM	
		31 521306451		\$252.60	Received				
40789	CINTAS CORPORATION	210324548	04/11/2017	\$250.38	Received	06/19/2017	0.1	\$252.60	ELECTRIC LIGHT AND POWER
		1 448106516		\$250.38	Received	06/27/2017		R&R-Invoice	UNIFORM RENTAL
43136	RANDYS UPHOLSTERY	14170	04/05/2017	\$250.00	Received	06/27/2017		Limited-PO	REPAIR THREE DEAT BOTTOM
		1 441206316		\$250.00	Received				
		LJ 1310 TK642 RECOVER SEATS		\$250.00	Received				
		001		1,000	Received	\$250.00			
70814	FAITH PRESBYTERIAN CHURCH	061517	06/15/2017	\$250.00	Received	06/27/2017		R&R-Invoice	USE FACILITY FOR ELECTIONS
		1 402206419		\$250.00	Received				05/02/17 & 06/06/17
71485	ANESTHESIA SERVICES ASSOCIATES	2990106	04/03/2017	\$247.01	Received	06/27/2017		R&R-Invoice	WALKER VELISA F(13J-67-WC)001
		1 407926481		\$247.01	Received				040317
61831	NAPA AUTO PARTS	JAC00037019604	05/31/2017	\$246.72	Received	05/31/2017		R&R-Invoice	MUNICIPAL GARAGE
		1 442406316		\$22.72	Received				
		1 442406316		\$224.00	Received				
60856	CITIBANK N A	1971405	05/22/2017	\$245.82	Received	06/27/2017		Regular-PO	MEASURE WHEEL
		85 855106218		\$245.82	Received				
		PJ 1070 Inspector Items		\$245.82	Received				
		001		3,000	Received	\$95.91			
		002		3,000	Received	\$149.91			
68585	WILLIAMS LANGELL	061217A	06/12/2017	\$245.00	Received	06/27/2017		R&R-Invoice	OFFICIAL PAY
		5 501266419		\$245.00	Received				
71962	LEE MARCUS A	061917	06/19/2017	\$245.00	Received	06/27/2017		R&R-Invoice	OFFICIAL PAY
		5 501266419		\$245.00	Received				
60427	MIPCO IMPRESSION PRODUCTS INC	131801	06/01/2017	\$242.65	Received	06/27/2017		R&R-Invoice	COPIER RENTAL

VENDOR PAYMENTS / FOR CLAIM DOCKET - 06/27/2017
 Report Title - AMOUNTS (DESCENDING) ALL TYPES
 Invoice Payments Under \$500

VEN#	VENDOR-NAME	INVOICE	INV-DATE	AMOUNT	AUTHORIZATION	DUE-DATE	REF-NUMBER	PAYMENT-TYPE	REMARKS
20377	ENTERGY	ADMINISTRATION	06/27/2017	\$242.65		06/27/2017	14867022	UTILITY-PAYM	
69953	INJURED WORKERS PHARMACY LLC	PARKS & RECREATION	04/07/2017	\$240.91		06/19/2017	0.1	\$240.91	ELECTRIC LIGHT AND POWER
69953	INJURED WORKERS PHARMACY LLC	GENERAL GOVERNMENT	04/07/2017	\$240.55		06/27/2017		R&R-Invoice	DEXTER SIMMONS 04/07/17
69953	INJURED WORKERS PHARMACY LLC	GENERAL GOVERNMENT	05/02/2017	\$240.55		06/27/2017		R&R-Invoice	DEXTER SIMMONS
60427	MIPCO IMPRESSION PRODUCTS INC	GENERAL GOVERNMENT	06/02/2017	\$240.55		06/27/2017		R&R-Invoice	COPIER RENTAL
72600	APPLIED SCIENCE LABS	PLANNING & DEVELOPMENT	06/15/2017	\$238.05		06/27/2017		R&R-Invoice	CHEMICALS TO SPRAY FOR BED
20225	ATMOS ENERGY	FIRE DEPARTMENT	06/27/2017	\$238.60		06/27/2017	3012724356	UTILITY-PAYM	BUGS AT FIRE STATIONS
61831	NAPA AUTO PARTS	PUBLIC SAFETY - POLICE	05/19/2017	\$237.10		06/21/2017	0.1	\$237.10	GAS
61831	NAPA AUTO PARTS	PUBLIC SAFETY - POLICE	05/19/2017	\$235.56		05/19/2017		R&R-Invoice	MUNICIPAL GARAGE
61831	NAPA AUTO PARTS	JAC00037019659	06/02/2017	\$234.13		06/02/2017		R&R-Invoice	MUNICIPAL GARAGE
20377	ENTERGY	PUBLIC WORKS	06/27/2017	\$233.91		06/27/2017	19832815	UTILITY-PAYM	
61831	NAPA AUTO PARTS	JAC00037019694	06/06/2017	\$234.33		06/06/2017		R&R-Invoice	MUNICIPAL GARAGE
20377	ENTERGY	PUBLIC SAFETY - POLICE	06/27/2017	\$233.91		06/27/2017	19832815	UTILITY-PAYM	
20377	ENTERGY	PARKS & RECREATION	06/27/2017	\$233.91		06/27/2017	16746083	UTILITY-PAYM	
72153	COMPREHENSIVE WELLNESS PHARMAC	PARKS & RECREATION	05/01/2017	\$231.50		06/19/2017	0.1	\$231.35	ELECTRIC LIGHT AND POWER
60293	POLK'S DISCOUNT DRUGS # 6	GENERAL GOVERNMENT	04/21/2017	\$230.19		06/27/2017		R&R-Invoice	WILLIAM L SKINNER 04/21/17
71759	DRAYER PHYSICAL THERAPY LLC	GENERAL GOVERNMENT	04/28/2017	\$230.04		06/27/2017		R&R-Invoice	ALIEN AARON(17J-09-WC)00
20377	ENTERGY	GENERAL GOVERNMENT	06/27/2017	\$227.02		06/27/2017	1666802	UTILITY-PAYM	
20377	ENTERGY	PARKS & RECREATION	06/27/2017	\$227.59		06/19/2017	0.1	\$227.02	ELECTRIC LIGHT AND POWER
20377	ENTERGY	PUBLIC SAFETY - POLICE	06/27/2017	\$227.59		06/27/2017	19833904	UTILITY-PAYM	
0-19833714		PUBLIC SAFETY - POLICE	06/19/2017	\$227.59		06/19/2017	0.1	\$227.59	ELECTRIC LIGHT AND POWER

VENDOR PAYMENTS / FOR CLAIM DOCKET - 06/27/2017
 Report Title - AMOUNTS (DESCENDING) ALL TYPES
 Invoice Payments Under \$500

VEN#	VENDOR-NAME	INVOICE	INV-DATE	AMOUNT	AUTHORIZATION	DUE-DATE	REF-NUMBER	PAYMENT-TYPE	REMARKS
60856	CITIBANK N A 1 453006461	970855 PUBLIC WORKS	05/03/2017	\$228.00 \$228.00		06/27/2017		Limited-PO	7/16 OSB
	LJ 1520 202 E. Pearl St. 001	7/16 4 x 8 OSB		16,000	Invoiced	\$228.00			
67755	FISHER ESTHER J 5 501266419	061917 PARKS & RECREATION	06/19/2017	\$227.50		06/27/2017		R&R-Invoice	OFFICIAL PAY
71785	STEWART MICHELLE 5 501266419	061217 PARKS & RECREATION	06/12/2017	\$227.50		06/27/2017		R&R-Invoice	OFFICIAL PAY
71785	STEWART MICHELLE 5 501266419	061917 PARKS & RECREATION	06/19/2017	\$227.50		06/27/2017		R&R-Invoice	OFFICIAL PAY
71820	HORTON KENTRELL 5 501266419	061217 PARKS & RECREATION	06/12/2017	\$227.50		06/27/2017		R&R-Invoice	OFFICIAL PAY
71820	HORTON KENTRELL 5 501266419	061917 PARKS & RECREATION	06/19/2017	\$227.50		06/27/2017		R&R-Invoice	OFFICIAL PAY
47027	MUNICIPAL SERVICES BUREAU 1 2352	665816 Liabilities	04/30/2017	\$226.23		06/27/2017		R&R-Invoice	COLLECTION AGENCY MUN COURT
47085	STUART C IRBY CO 1 453006461	S010511402.001 PUBLIC WORKS	05/24/2017	\$226.92		06/27/2017		Limited-PO	SYLV 64479 M175/U/MED HID LAMP
	LJ 1701 Union Station 001	SYLV 64479 M175/U/Med Hid Lamp		15,000	Invoiced	\$226.92			
06371	PETTY CASH-FINANCE/TRAVEL 85 855106473	13416 PLANNING & DEVELOPMENT	06/12/2017	\$225.40		06/27/2017		R&R-Invoice	MEALS/TIPS-JOHN R AVERY ARLINGTON, TX
06371	PETTY CASH-FINANCE/TRAVEL 85 855106473	13417 PLANNING & DEVELOPMENT	06/12/2017	\$225.40		06/27/2017		R&R-Invoice	MEALS/TIPS-JOHN A ANDERSON ARLINGTON, TX
03481	CAPITOL TOWING INC 1 442206465	82826/85035 PUBLIC SAFETY - POLICE	04/12/2017	\$225.00		06/27/2017		R&R-Invoice	WRECKER SERVICES 85251 82812 82692
68191	GROVES SHEET METAL INC 5 501266311	2247 PARKS & RECREATION	04/04/2017	\$224.75		06/27/2017		Limited-PO	GA TUBE AND DOOR HINGE
	LJ 1224 battlefield			\$224.75					
	001	1 X 1 11GA SQUARE TUBE		4,000	Invoiced	\$96.00			
	002	1/2" X 1/2" STEEL BAR		3,000	Invoiced	\$30.00			
	003	DOOR HINGES		1,000	Invoiced	\$98.75			
06371	PETTY CASH-FINANCE/TRAVEL 85 809106473	13431 PLANNING & DEVELOPMENT	06/12/2017	\$222.89		06/27/2017		R&R-Invoice	HOTEL-CHARLES RICHARDSON GONZALES, LA
61831	NAPA AUTO PARTS 1 442406316	JAC00037019732 PUBLIC SAFETY - POLICE	06/08/2017	\$222.90		06/08/2017		R&R-Invoice	MUNICIPAL GARAGE
	1 442406316	PUBLIC SAFETY - POLICE		\$222.40					
69925	THE MISSISSIPPI LINK NEWSPAPERS 1 442716444	17024 PUBLIC SAFETY - POLICE	05/25/2017	\$216.00		06/27/2017		R&R-Invoice	PUBLIC AUCTION IMPOUND LOT JUNE 21 2017 5/11/ 5/18 5/25 4225 MICHAEL AVALON STREET 2400 WORDS
20377	ENTERGY	PUBLIC SAFETY - POLICE		\$216.00					
				\$209.05					

AP755 VENDOR PAYMENTS / FOR CLAIM DOCKET - 06/27/2017
 Report Title - AMOUNTS (DESCENDING) ALL TYPES
 Invoice Payments Under \$500

VEN#	VENDOR-NAME	INVOICE	INV-DATE	AMOUNT	AUTHORIZATION	DUE-DATE	REF-NUMBER	PAYMENT-TYPE	REMARKS
61831	NAPA AUTO PARTS	JAC00037019693	06/06/2017	\$208.43		06/19/2017	0.1	\$209.05	ELECTRIC LIGHT AND POWER
	0+16489171	PARKS & RECREATION		\$209.05		06/06/2017			MUNICIPAL GARAGE
	1 442406316	PUBLIC SAFETY - POLICE		\$42.52					
	1 442406316	PUBLIC SAFETY - POLICE		\$42.52					
	1 442406316	PUBLIC SAFETY - POLICE		\$86.63					
	1 442406316	PUBLIC SAFETY - POLICE		\$18.00					
	1 442406316	PUBLIC SAFETY - POLICE		\$18.00-					
	1 442406316	PUBLIC SAFETY - POLICE		\$36.76					
69953	INURED WORKERS PHARMACY LLC	3194699/041017	04/10/2017	\$208.40		06/27/2017		R&R-Invoice	DEXTER SIMMONS 04/10/17
	1 407926212	GENERAL GOVERNMENT		\$208.40					
69953	INURED WORKERS PHARMACY LLC	3247319	05/04/2017	\$208.40		06/27/2017		R&R-Invoice	DEXTER SIMMONS
	1 407926212	GENERAL GOVERNMENT		\$208.40					
72153	COMPREHENSIVE WELLNESS PHARMAC	05102017	05/10/2017	\$207.12		06/27/2017		R&R-Invoice	VELISA WALKER 05/10/17
	1 407926212	GENERAL GOVERNMENT		\$207.12					
61831	NAPA AUTO PARTS	JAC00037019626	06/01/2017	\$206.90		06/01/2017		R&R-Invoice	MUNICIPAL GARAGE
	1 406106316	ADMINISTRATION		\$206.90					
20377	ENTERGY	18292615\	06/27/2017	\$205.34		06/27/2017	18292896	UTILITY-PAYM	
	5 504106451	PARKS & RECREATION		\$205.34					
	0+18292615	PARKS & RECREATION		\$205.34		06/19/2017	0.1	\$205.34	ELECTRIC LIGHT AND POWER
69162	GENESIS PHYSICAL THERAPY	1496318B	01/17/2017	\$204.12		06/27/2017		R&R-Invoice	MARCUS MYERS 01/17/17
	1 407926481	GENERAL GOVERNMENT		\$204.12					
70366	SOS SERVICES	AAA01084	05/10/2017	\$204.00		06/27/2017		R&R-Invoice	MICROSCOPE PREVENTATIVE MAINTENANCE
	1 442246464	PUBLIC SAFETY - POLICE		\$204.00					
31330	AIRGAS USA LLC	9945338598	05/31/2017	\$202.69		06/27/2017		R&R-Invoice	CYLINDER RENTAL
	31 521356514	PUBLIC WORKS		\$202.69					
67801	GENESIS PT & REHAB SERVICES LL	1541341A	04/17/2017	\$200.34		06/27/2017		R&R-Invoice	TILLER TERRANCE(17J-27-WC)00
	1 407926481	GENERAL GOVERNMENT		\$200.34					041717
67801	GENESIS PT & REHAB SERVICES LL	1543468A	04/20/2017	\$200.34		06/27/2017		R&R-Invoice	TILLER TERRANCE(17J-27-WC)00
	1 407926481	GENERAL GOVERNMENT		\$200.34					042017
72634	JUNTEENTH JACKSON	061917	06/19/2017	\$200.00		06/27/2017		R&R-Invoice	DAMAGE DEPOSIT REFUND
	5 2323	Liabilities		\$200.00					
63860	ROWLAND G GARRETT	2017-607	06/06/2017	\$193.50		06/27/2017		Limited-PO	FLOOR FINISH
	5 501256213	PARKS & RECREATION		\$193.50					
	LJ 1741 Parks and Rec.			\$193.50					
	001	5 Gallon Pails of G & G Classi		2.000	Invoiced	\$136.00			
	002	5 Gallon Pail of Pride Super S		1.000	Invoiced	\$57.50			
66021	COMCAST CABLE	09577 771766-01-4/060317	06/03/2017	\$193.88		06/27/2017		R&R-Invoice	09577 771766-01-4 CABLE SERVICE
	1 442106419	PUBLIC SAFETY - POLICE		\$193.88					
68585	WILLIAMS LANGELL	061217	06/12/2017	\$192.50		06/27/2017		R&R-Invoice	OFFICIAL PAY
	5 501266419	PARKS & RECREATION		\$192.50					
71021	RIVER CITY REHABILITATION LLC	7699928083	05/01/2017	\$192.78		06/27/2017		R&R-Invoice	NUTALL LEWIS(00J-10-WC)00

AP755 VENDOR PAYMENTS / FOR CLAIM DOCKET - 06/27/2017
 Report Title - AMOUNTS (DESCENDING) ALL TYPES
 Invoice Payments Under \$500

VEN#	VENDOR-NAME	INVOICE	INV-DATE	AMOUNT	AUTHORIZATION	DUE-DATE	REF-NUMBER	PAYMENT-TYPE	REMARKS
71021	RIVER CITY REHABILITATION LLC	GENERAL GOVERNMENT	05/02/2017	\$192.78		06/27/2017		R&R-Invoice	NUTTALL LEWIS(00J-10-WC)00
71021	RIVER CITY REHABILITATION LLC	GENERAL GOVERNMENT	05/05/2017	\$192.78		06/27/2017		R&R-Invoice	NUTTALL LEWIS(00J-10-WC)00
71021	RIVER CITY REHABILITATION LLC	GENERAL GOVERNMENT	05/08/2017	\$192.78		06/27/2017		R&R-Invoice	NUTTALL LEWIS(00J-10-WC)00
71962	LEE MARCUS A	GENERAL GOVERNMENT	06/12/2017	\$192.78		06/27/2017		R&R-Invoice	OFFICIAL PAY
20377	EMERGENCY	PARKS & RECREATION	06/27/2017	\$191.21		06/27/2017	16488975	UTILITY-PAYM	
40789	CINTAS CORPORATION	PARKS & RECREATION	05/23/2017	\$191.33		06/19/2017	0.1	\$191.21	ELECTRIC LIGHT AND POWER
40789	CINTAS CORPORATION	PUBLIC WORKS	05/30/2017	\$191.33		06/27/2017		R&R-Invoice	UNIFORM RENTAL
40789	CINTAS CORPORATION	PUBLIC WORKS	06/06/2017	\$191.33		06/27/2017		R&R-Invoice	UNIFORM RENTAL
61831	NAPA AUTO PARTS	JAC00037019696	06/06/2017	\$191.60		06/06/2017		R&R-Invoice	MUNICIPAL GARAGE
71485	ANESTHESIA SERVICES ASSOCIATES	PUBLIC SAFETY - POLICE	04/03/2017	\$192.00		06/27/2017		R&R-Invoice	WALKER VELISA F(13J-67-WC)001
64479	MS ECONOMIC DEVELOPMENT COUNCI	PUBLIC SAFETY - POLICE	06/01/2017	\$192.00		06/27/2017		R&R-Invoice	2017-2018 MEDC MEMBERSHIP
70181	PODIATRY CARE ASSOCIATES	GENERAL GOVERNMENT	01/17/2017	\$185.00		06/27/2017		R&R-Invoice	NATHANIEL ROBINSON 01/17/17
61831	NAPA AUTO PARTS	JAC00037019494	05/19/2017	\$183.17		05/19/2017		R&R-Invoice	MUNICIPAL GARAGE
		PUBLIC WORKS		\$77.76					
		PUBLIC WORKS		\$58.78					
		PUBLIC WORKS		\$2.30					
		PUBLIC WORKS		\$16.33					
		PUBLIC WORKS		\$13.70					
		PUBLIC WORKS		\$6.15					
		PUBLIC WORKS		\$8.25					
		PUBLIC WORKS		\$3.10					
		PUBLIC WORKS		\$6.15-					
61831	NAPA AUTO PARTS	JAC00037019520	05/22/2017	\$180.24		05/22/2017		R&R-Invoice	MUNICIPAL GARAGE
06371	PETTY CASH-FINANCE/TRAVEL	PUBLIC WORKS	06/12/2017	\$179.17		06/27/2017		R&R-Invoice	MEALS-JAQUANA GLASPER
		PLANNING & DEVELOPMENT		\$179.17					MURREESBORO, TN - TRAINING

VENDOR PAYMENTS / FOR CLAIM DOCKET - 06/27/2017
 Report Title - AMOUNTS (DESCENDING) ALL TYPES
 Invoice Payments Under \$500

VEN#	VENDOR-NAME	INVOICE	INV-DATE	AMOUNT	AUTHORIZATION	DUE-DATE	REF-NUMBER	PAYMENT-TYPE	REMARKS
06371	PETTY CASH-FINANCE/TRAVEL	13405	06/12/2017	\$179.17		06/27/2017		R&R-Invoice	MEALS/TIPS-SYLIVIA ROWSEY
	85 809106473	PLANNING & DEVELOPMENT		\$179.17				R&R-Invoice	MURFREESBORO, TN - TRAINING
66746	SPANN ALEXANDER	061917	06/19/2017	\$180.00		06/27/2017		R&R-Invoice	OFFICIAL PAY
	5 501266419	PARKS & RECREATION		\$180.00				R&R-Invoice	COPIER RENTAL
60427	MIRCO IMPRESSION PRODUCTS INC	131802	06/01/2017	\$178.52		06/27/2017		R&R-Invoice	
	1 451246514	PUBLIC WORKS		\$89.26				R&R-Invoice	
	1 451256514	PUBLIC WORKS		\$89.26				R&R-Invoice	
61831	NAPA AUTO PARTS	JAC00037019640	06/02/2017	\$177.01		06/02/2017		R&R-Invoice	MUNICIPAL GARAGE
	1 442406316	PUBLIC SAFETY - POLICE		\$166.67				R&R-Invoice	
	1 442406316	PUBLIC SAFETY - POLICE		\$10.34				R&R-Invoice	
61831	NAPA AUTO PARTS	JAC00037019597	05/30/2017	\$176.22		05/30/2017		R&R-Invoice	MUNICIPAL GARAGE
	1 442406316	PUBLIC SAFETY - POLICE		\$62.05				R&R-Invoice	
	1 442406316	PUBLIC SAFETY - POLICE		\$55.53				R&R-Invoice	
	1 442406316	PUBLIC SAFETY - POLICE		\$58.64				R&R-Invoice	
60856	CITIBANK N A	8971544	05/25/2017	\$175.52		06/27/2017		Limited-PO	BLEACH SPRAYER
	31 521306317	PUBLIC WORKS		\$175.52				Limited-PO	
	LJ 1704 J. H. Fewell			\$175.52				Limited-PO	
	001	TWS Waterproofing Wood Protect		1.000	Invoiced	\$13.47			
	002	1.5 Gal. Bleach Sprayer		1.000	Invoiced	\$14.98			
	003	2 x 8-12 Ft. # 2 Prime Pt Gc		11.000	Invoiced	\$147.07			
68976	STONERIVER	44364011	05/04/2017	\$174.80		06/27/2017		R&R-Invoice	SAM SANDIFER
	1 407926212	GENERAL GOVERNMENT		\$174.80				R&R-Invoice	
61831	NAPA AUTO PARTS	JAC00037019518	05/22/2017	\$173.26		05/22/2017		R&R-Invoice	MUNICIPAL GARAGE
	1 448206316	PUBLIC WORKS		\$173.26				R&R-Invoice	
	1 448206316	PUBLIC WORKS		\$36.00				R&R-Invoice	
	1 448206316	PUBLIC WORKS		\$36.00-				R&R-Invoice	
39821	FOXWORTH CHIRO CLINIC	829917/04/07/17	04/07/2017	\$172.74		06/27/2017		R&R-Invoice	LINDA LINDSEY
	1 407926481	GENERAL GOVERNMENT		\$172.74				R&R-Invoice	
39821	FOXWORTH CHIRO CLINIC	829917S	04/20/2017	\$172.74		06/27/2017		R&R-Invoice	LINDSEY LINDA(15J-79-WC)00
	1 407926481	GENERAL GOVERNMENT		\$172.74				R&R-Invoice	
59466	W W GRAINGER, INC	9408355551	04/06/2017	\$171.74		06/27/2017		Limited-PO	PUSH BROOKS & DUST MOP
	1 443106299	ADMINISTRATION		\$171.74				Limited-PO	9408355569
	LJ 1294 Telecommunications			\$171.74				Limited-PO	
	001	Push Broom, Synthetic, 36" Blø		2.000	Invoiced	\$81.48			
	002	Handle, Wood, Natural, 60 in.		2.000	Invoiced	\$14.18			
	003	Broom Brace, Metal, Silver, 12		2.000	Invoiced	\$10.92			
	004	Dust Mop Kit, 36"L, Cotton		2.000	Invoiced	\$65.16			
61831	NAPA AUTO PARTS	JAC00037019643	06/02/2017	\$171.57		06/02/2017		R&R-Invoice	MUNICIPAL GARAGE
	1 442406316	PUBLIC SAFETY - POLICE		\$13.61				R&R-Invoice	
	1 442406316	PUBLIC SAFETY - POLICE		\$53.62				R&R-Invoice	
	1 442406316	PUBLIC SAFETY - POLICE		\$.99				R&R-Invoice	
	1 442406316	PUBLIC SAFETY - POLICE		\$7.24				R&R-Invoice	

VENDOR PAYMENTS / FOR CLAIM DOCKET - 06/27/2017
 Report Title - AMOUNTS (DESCENDING) ALL TYPES
 Invoice Payments Under \$500

VEN#	VENDOR-NAME	INVOICE	INV-DATE	AMOUNT	AUTHORIZATION	DUE-DATE	REF-NUMBER	PAYMENT-TYPE	REMARKS
67801	GENESIS PT & REHAB SERVICES LLC	PUBLIC SAFETY - POLICE	04/13/2017	\$171.72		06/27/2017		R&R-Invoice	TILLER TERRANCE(17J-27-WC)00
46910	REHABILITATION INC	GENERAL SAFETY - POLICE	03/27/2017	\$171.72		06/27/2017		R&R-Invoice	041317
40789	CINTAS CORPORATION	GENERAL GOVERNMENT	05/16/2017	\$169.08		06/27/2017		R&R-Invoice	JERMAINE PULLUM 03/27/17
67938	INTEGRATED PEST SERVICES	PUBLIC WORKS	06/06/2017	\$170.00		06/27/2017		R&R-Invoice	UNIFORM RENTAL
61831	NAPA AUTO PARTS	HUMAN & CULTURAL SERVICES	05/30/2017	\$168.76		05/30/2017		R&R-Invoice	PEST CONTROL FOR EARLY CHILDHOOD CENTERS
61831	NAPA AUTO PARTS	PUBLIC WORKS	06/06/2017	\$167.42		06/06/2017		R&R-Invoice	MUNICIPAL GARAGE
69925	THE MISSISSIPPI LINK NEWSPAPERS	GENERAL GOVERNMENT	06/01/2017	\$167.95		06/27/2017		R&R-Invoice	MUNICIPAL GARAGE
43122	WASTE MANAGEMENT OF MS INC	PUBLIC SAFETY - POLICE	06/01/2017	\$165.75		06/27/2017		R&R-Invoice	ORDINANCE AMENDING SECTIONS OF ORDINANCES CITY OF JACKSON
71092	MS STATE TAX COMMISSION	PUBLIC SAFETY - POLICE	06/14/2017	\$165.75		06/27/2017		R&R-Invoice	CHAPTER 62 OF THE CODE OF GOVERNING FLOOD DAMAGE PREVENT
61831	NAPA AUTO PARTS	PUBLIC WORKS	05/23/2017	\$164.33		05/23/2017		R&R-Invoice	DISPOSAL CONTRACT
70423	RUSSELL SHERRI L	PUBLIC WORKS	06/16/2017	\$163.32		06/27/2017		R&R-Invoice	RENEWAL TAGS
20225	ATMOS ENERGY	PUBLIC WORKS	06/27/2017	\$162.96		06/27/2017	3012724356	UTILITY-PAYM	MUNICIPAL GARBAGE

AP755 VENDOR PAYMENTS / FOR CLAIM DOCKET - 06/27/2017
 Report Title - AMOUNTS (DESCENDING) ALL TYPES
 Invoice Payments Under \$500

VEN#	VENDOR-NAME	INVOICE	INV-DATE	AMOUNT	AUTHORIZATION	DUE-DATE	REF-NUMBER	PAYMENT-TYPE	REMARKS
60427	0+3012763822 MIPCO IMPRESSION PRODUCTS INC	1 441706453	06/01/2017	\$160.70		06/21/2017	0.1	\$162.96	GAS
	1 448106514	131806	06/01/2017	\$160.70		06/21/2017			COPIER RENTAL
60427	MIPCO IMPRESSION PRODUCTS INC	131812	06/01/2017	\$160.68		06/27/2017			COPIER RENTAL
20377	1 451106514 ENTERGY	PUBLIC WORKS	06/27/2017	\$159.68		06/27/2017			UTILITY-PAYM
	5 504106451	16668030\	06/27/2017	\$159.68		16668378			
	0+16668030	PARKS & RECREATION	06/12/2017	\$157.50		06/19/2017	0.1	\$159.68	ELECTRIC LIGHT AND POWER
67755	FISHER ESTHER J	061217	06/12/2017	\$157.50		06/27/2017			OFFICIAL PAY
43378	5 501266419 JACKSON HMA LLC	PARKS & RECREATION	04/18/2017	\$155.95		06/27/2017			SMITH MIRON B(17J-33-WC)00
40789	1 407926481 CINTAS CORPORATION	4533898	05/30/2017	\$153.75		06/27/2017			4182017
	5 504526516	GENERAL GOVERNMENT	05/30/2017	\$153.75		06/27/2017			UNIFORM RENTAL
46958	31 521356419 WAYPOINT ANALYTICAL	210345865	05/15/2017	\$154.00		06/27/2017			LAB SAMPLES
	31 521356419	PARKS & RECREATION	05/24/2017	\$154.00		06/27/2017			LAB SAMPLES
46958	1034122 WAYPOINT ANALYTICAL	PUBLIC WORKS	05/30/2017	\$154.00		06/27/2017			LAB SAMPLES
46958	31 521356419 WAYPOINT ANALYTICAL	PUBLIC WORKS	05/30/2017	\$154.00		06/27/2017			LAB SAMPLES
61831	31 521356419 NAPA AUTO PARTS	PUBLIC WORKS	05/19/2017	\$152.99		05/19/2017			MUNICIPAL GARAGE
61831	1 453006316 NAPA AUTO PARTS	JAC00037019475	06/06/2017	\$152.99		06/06/2017			MUNICIPAL GARAGE
61831	31 521206316 NAPA AUTO PARTS	JAC00037019697	06/05/2017	\$150.60		06/05/2017			MUNICIPAL GARAGE
70995	1 453006316 TAYLOR VODIE	PUBLIC WORKS	06/13/2017	\$150.12		06/27/2017			EMPLOYEE MILEAGE REIMBURSEMENT
06371	81 598106472 PERRY CASH-FINANCE/TRAVEL	06132017	06/12/2017	\$150.00		06/27/2017			
	85 809206443	HUMAN & CULTURAL SERVICES	06/27/2017	\$149.50		16664302			REGISTRATION-MARY MANOGIN
20377	1 442206451 ENTERGY	PLANNING & DEVELOPMENT	06/27/2017	\$149.50		06/27/2017			TUNICA, MS - CONFERENCE
	0+16664021	16664021\	06/19/2017	\$149.43		06/19/2017	0.1	\$149.50	UTILITY-PAYM
40789	31 521506516 CINTAS CORPORATION	PUBLIC SAFETY - POLICE	05/16/2017	\$149.43		06/27/2017			ELECTRIC LIGHT AND POWER
61831	1 442406316 NAPA AUTO PARTS	PUBLIC WORKS	05/24/2017	\$149.95		05/24/2017			UNIFORM RENTAL
61831	1 442406316 NAPA AUTO PARTS	JAC00037019557	06/01/2017	\$149.61		06/01/2017			MUNICIPAL GARAGE
61831	1 442406316 NAPA AUTO PARTS	JAC00037019632	06/01/2017	\$135.09		06/01/2017			MUNICIPAL GARAGE
70190	1 442406316 ROBINSON DONTAWEON	PUBLIC SAFETY - POLICE	06/15/2017	\$7.29		06/27/2017			MUNICIPAL GARAGE
	061517	PUBLIC SAFETY - POLICE	06/15/2017	\$150.00		06/27/2017			BOX HELPER ELECTION 06/06/17

VENDOR PAYMENTS / FOR CLAIM DOCKET - 06/27/2017
 Report Title - AMOUNTS (DESCENDING) ALL TYPES
 Invoice Payments Under \$500

VEN#	VENDOR-NAME	INVOICE	INV-DATE	AMOUNT	AUTHORIZATION	DUE-DATE	REF-NUMBER	PAYMENT-TYPE	REMARKS
70440	WEBB RUTHIE	GENERAL GOVERNMENT	06/20/2017	\$150.00		06/27/2017		R&R-Invoice	OFFICIAL PAY
71048	ELLIS ANTMWAIN	PARKS & RECREATION	06/15/2017	\$150.00		06/27/2017		R&R-Invoice	BOX HELPER ELECTION 06/06/17
72351	ROBINSON CECILIA	GENERAL GOVERNMENT	06/15/2017	\$150.00		06/27/2017		R&R-Invoice	BOX HELPER ELECTION 06/06/17
B1996	YOUNG MARK	GENERAL GOVERNMENT	06/01/2017	\$150.00		06/27/2017		R&R-Invoice	FULL & COMPLETE SETTLEMENT
61831	NAPA AUTO PARTS	GENERAL GOVERNMENT	06/01/2017	\$148.24		06/01/2017		R&R-Invoice	MUNICIPAL GARAGE
13700	PITNEY BOWES GLOBAL FINANCIAL	PUBLIC WORKS	06/13/2017	\$147.84		06/27/2017		R&R-Invoice	LEASE PAYMENT MAILING SYSTEM
67801	GENESIS PT & REHAB SERVICES LL	GENERAL GOVERNMENT	04/24/2017	\$147.42		06/27/2017		R&R-Invoice	TILLER TERRANCE(17J-27-WC) 00 042417
11058	MID-SOUTH UNIFORM & SUPPLY	GENERAL GOVERNMENT	06/02/2017	\$146.45		06/27/2017		Limited-PO	STINGER C4 LED HL DC CHARGER
LJ	1745 PT-604	FIRE DEPARTMENT		\$146.45					
	001	FLASHLIGHT		1.000	Received	\$146.45			
40789	CINTAS CORPORATION	PARKS & RECREATION	06/06/2017	\$146.12		06/27/2017		R&R-Invoice	UNIFORM RENTAL
61831	NAPA AUTO PARTS	JAC00037019721	06/07/2017	\$146.43		06/07/2017		R&R-Invoice	MUNICIPAL GARAGE
	1 451256316	PUBLIC WORKS		\$44.39					
	1 451256316	PUBLIC WORKS		\$12.17					
	1 451256316	PUBLIC WORKS		\$4.39					
	1 451256316	PUBLIC WORKS		\$8.83					
	1 451256316	PUBLIC WORKS		\$6.61					
	1 451256316	PUBLIC WORKS		\$22.23					
	1 451256316	PUBLIC WORKS		\$46.67					
61831	NAPA AUTO PARTS	PUBLIC WORKS	05/19/2017	\$1.14		05/19/2017		R&R-Invoice	MUNICIPAL GARAGE
	31 521406316	PUBLIC WORKS		\$25.88					
	31 521406316	PUBLIC WORKS		\$79.88					
	31 521406316	PUBLIC WORKS		\$18.00					
	31 521406316	PUBLIC WORKS		\$18.00-					
	31 521406316	PUBLIC WORKS		\$39.48					
70536	THOMPSON JOHNNIE FAYE	PUBLIC WORKS	06/07/2017	\$145.00		06/27/2017		R&R-Invoice	POLL MANAGER ELECTION 06/06/17
	1 402206419	GENERAL GOVERNMENT		\$145.00					
40789	CINTAS CORPORATION	GENERAL GOVERNMENT	06/06/2017	\$143.92		06/27/2017		R&R-Invoice	UNIFORM RENTAL
	1 457006516	PUBLIC WORKS		\$143.92					
20377	ENERGY	PUBLIC WORKS	06/27/2017	\$140.14		06/27/2017	15681703	UTILITY-PAYM	
	9 506106451	PUBLIC WORKS		\$140.14					

VENDOR PAYMENTS / FOR CLAIM DOCKET - 06/27/2017
 Report Title - AMOUNTS (DESCENDING) ALL TYPES
 Invoice Payments Under \$500

VEN#	VENDOR-NAME	INVOICE	INV-DATE	AMOUNT	AUTHORIZATION	DUE-DATE	REF-NUMBER	PAYMENT-TYPE	REMARKS
20377	ENTERGY	85440428\	06/27/2017	\$140.69		06/19/2017	0.1	\$140.14	ELECTRIC LIGHT AND POWER
	0+85440428	1 442446451				06/27/2017	85449734	UTILITY-PAYM	
				\$140.69			0.1	\$140.69	ELECTRIC LIGHT AND POWER
40789	CINTAS CORPORATION	210350022	06/08/2017	\$140.93		06/27/2017		R&R-Invoice	UNIFORM RENTAL
	31 521356516			\$140.93					
61190	SOUTHERN HOSE & INDUSTRIAL INC	091053	02/03/2017	\$140.10		06/27/2017		Limited-PO	HYD HOS ASSEMBL
	5 504106316			\$140.10					
	LJ 890 VARIOUS			\$140.10					
	001	T 216 HYDRAULIC HOSE		1.000	Received	\$140.10			
61831	NABA AUTO PARTS	JAC00037019568	05/25/2017	\$140.04		05/25/2017		R&R-Invoice	MUNICIPAL GARAGE
	1 442406316			\$117.78					
	1 442406316			\$11.13					
63932	DAVIS ARTHUR	062017	06/20/2017	\$140.00		06/27/2017		R&R-Invoice	OFFICIAL PAY
	5 501266419			\$140.00					
68267	UNIVERSITY PHYSICIANS	164561510	03/08/2017	\$139.08		06/27/2017		R&R-Invoice	SMITH MIRON B(17J-33-WC)00
	1 407926481			\$139.08					030817
68680	HARPER SANDRA ANITA	062017	06/20/2017	\$140.00		06/27/2017		R&R-Invoice	OFFICIAL PAY
	5 501266419			\$140.00					
20377	ENTERGY	92216001\	06/27/2017	\$138.07		06/27/2017	92368539	UTILITY-PAYM	
	1 454006451			\$138.07					
	0+92216001	1 454006451				06/19/2017	0.1	\$138.07	ELECTRIC LIGHT AND POWER
68267	UNIVERSITY PHYSICIANS	166535840	04/17/2017	\$138.17		06/27/2017		R&R-Invoice	DEXTER SIMMONS 04/17/17
	1 407926481			\$138.17					
69214	FIRST INTERMED CORPORATION	792505	04/10/2017	\$138.17		06/27/2017		R&R-Invoice	TILLER TERRANCE(17J-27-WC)00
	1 407926481			\$138.17					041017
69214	FIRST INTERMED CORPORATION	803188	04/26/2017	\$138.17		06/27/2017		R&R-Invoice	TILLER TERRANCE(17J-27-WC)00
	1 407926481			\$138.17					04262017
00433	HINDS COUNTY CHANCERY CLERK	05182017	03/08/2017	\$138.00		06/27/2017		R&R-Invoice	6 LIEN NOTICES & RESTRICTIONS
	85 845106485			\$138.00					FUNDING
71857	MAC HAIR CHRYSLER	323402	05/22/2017	\$137.50		06/27/2017		Limited-PO	FOR PROPERTIES RECEIVING CDBG
	1 442406316			\$137.50					TIGHTENED PINS REPAIRED
				\$137.50					WENT OFF LABOR
				\$137.50					CONNECTION AND BATTERY LIGHT
	LJ 1587 PC 1713 REPAIR BATTERY CHARGER			\$137.50					
	001	PC 1713 REPAIR BATTERY CHARGER		1.000	Received	\$137.50			
40789	CINTAS CORPORATION	210348859	06/06/2017	\$136.36		06/27/2017		R&R-Invoice	UNIFORM RENTAL
	1 448106516			\$136.36					
61831	NABA AUTO PARTS	JAC00037019519	05/22/2017	\$136.54		05/22/2017		R&R-Invoice	MUNICIPAL GARAGE
	31 521406316			\$77.76					
	31 521406316			\$58.78					

AP755
 VENDOR PAYMENTS / FOR CLAIM DOCKET - 06/27/2017
 Report Title - AMOUNTS (DESCENDING) ALL TYPES
 Invoice Payments Under \$500

VEN#	VENDOR-NAME	INVOICE	INV-DATE	AMOUNT	AUTHORIZATION	DUE-DATE	REF-NUMBER	PAYMENT-TYPE	REMARKS
61831	NAPA AUTO PARTS	JAC00037019617	06/01/2017	\$136.32		06/01/2017		R&R-Invoice	MUNICIPAL GARAGE
61831	NAPA AUTO PARTS	PUBLIC SAFETY - POLICE		\$136.32					
61831	NAPA AUTO PARTS	JAC00037019629	06/01/2017	\$136.54		06/01/2017		R&R-Invoice	MUNICIPAL GARAGE
61831	NAPA AUTO PARTS	PUBLIC WORKS		\$77.76					
61831	NAPA AUTO PARTS	PUBLIC WORKS		\$58.78					
40432	AIRGAS USA INC	9945334414	05/31/2017	\$135.89		06/27/2017		R&R-Invoice	CYLINDER RENTAL
61831	NAPA AUTO PARTS	FIRE DEPARTMENT		\$135.89					
61831	NAPA AUTO PARTS	JAC00037019545	05/23/2017	\$135.26		05/23/2017		R&R-Invoice	MUNICIPAL GARAGE
61831	NAPA AUTO PARTS	PUBLIC SAFETY - POLICE		\$93.90					
61831	NAPA AUTO PARTS	PUBLIC SAFETY - POLICE		\$41.36					
46371	STANTON BODY SHOP	19365	04/28/2017	\$135.00		06/27/2017		R&R-Invoice	19365 19358 19354 WRECKER SERVICE
61831	NAPA AUTO PARTS	PUBLIC SAFETY - POLICE		\$135.00					
61831	NAPA AUTO PARTS	JAC00037019486	05/19/2017	\$134.72		05/19/2017		R&R-Invoice	MUNICIPAL GARAGE
61831	NAPA AUTO PARTS	PUBLIC WORKS		\$134.72					
61831	NAPA AUTO PARTS	JAC00037019572	05/25/2017	\$134.72		05/25/2017		R&R-Invoice	MUNICIPAL GARAGE
61831	NAPA AUTO PARTS	PUBLIC WORKS		\$134.72					
68267	UNIVERSITY PHYSICIANS	166392400	04/11/2017	\$134.62		06/27/2017		R&R-Invoice	DEXTER SIMMONS 04/11/17
20225	ATMOS ENERGY	GENERAL GOVERNMENT		\$134.62					
20225	ATMOS ENERGY	1279916058	06/27/2017	\$133.52		06/27/2017	3012724356	UTILITY-PAYM	
61831	NAPA AUTO PARTS	PARKS & RECREATION		\$133.52					
61831	NAPA AUTO PARTS	JAC00037019558	05/24/2017	\$133.78		06/21/2017	0.1	\$133.52 GAS	
61831	NAPA AUTO PARTS	HUMAN & CULTURAL SERVICES		\$5.10					
61831	NAPA AUTO PARTS	HUMAN & CULTURAL SERVICES		\$5.35					
61831	NAPA AUTO PARTS	HUMAN & CULTURAL SERVICES		\$123.33					
61831	NAPA AUTO PARTS	JAC00037019710	06/07/2017	\$133.52		06/07/2017		R&R-Invoice	MUNICIPAL GARAGE
61831	NAPA AUTO PARTS	PUBLIC SAFETY - POLICE		\$57.88					
61831	NAPA AUTO PARTS	PUBLIC SAFETY - POLICE		\$12.72					
61831	NAPA AUTO PARTS	PUBLIC SAFETY - POLICE		\$10.50					
61831	NAPA AUTO PARTS	PUBLIC SAFETY - POLICE		\$52.42					
40789	CINTAS CORPORATION	210348866	06/06/2017	\$130.76		06/27/2017		R&R-Invoice	UNIFORM RENTAL
61831	NAPA AUTO PARTS	PUBLIC WORKS		\$130.76					
61831	NAPA AUTO PARTS	JAC00037019510	05/22/2017	\$130.20		05/22/2017		R&R-Invoice	MUNICIPAL GARAGE
61831	NAPA AUTO PARTS	PUBLIC SAFETY - POLICE		\$59.45					
61831	NAPA AUTO PARTS	PUBLIC SAFETY - POLICE		\$25.99					
61831	NAPA AUTO PARTS	PUBLIC SAFETY - POLICE		\$23.95					
61831	NAPA AUTO PARTS	PUBLIC SAFETY - POLICE		\$8.06					
61831	NAPA AUTO PARTS	PUBLIC SAFETY - POLICE		\$12.75					
61831	NAPA AUTO PARTS	JAC00037019530	05/22/2017	\$130.68		05/22/2017		R&R-Invoice	MUNICIPAL GARAGE
61831	NAPA AUTO PARTS	PUBLIC SAFETY - POLICE		\$130.68					
06371	PETTY CASH-FINANCE/TRAVEL	19421	06/12/2017	\$129.03		06/27/2017		R&R-Invoice	MEALS/TIPS-MICHAEL DAVIS LAS VEGAS, NV - CONFERENCE
06371	PETTY CASH-FINANCE/TRAVEL	PLANNING & DEVELOPMENT		\$129.03					

AP755 VENDOR PAYMENTS / FOR CLAIM DOCKET - 06/27/2017
 Report Title - AMOUNTS (DESCENDING) ALL TYPES
 Invoice Payments Under \$500

VEN#	VENDOR-NAME	INVOICE	INV-DATE	AMOUNT	AUTHORIZATION	DUE-DATE	REF-NUMBER	PAYMENT-TYPE	REMARKS
31658	MS MOC PROPERTIES LLC	1117596/05042017	05/04/2017	\$130.00		06/27/2017		R&R-Invoice	1117596 MCWILLIAMS JERRY
		GENERAL GOVERNMENT		\$130.00					(05J-213WC)00
69565	FUNCHES CATHY	06142017	06/14/2017	\$129.06		06/27/2017		R&R-Invoice	EMPLOYEE MILEAGE REIMBURSEMENT
	134 438106476	HUMAN & CULTURAL SERVICES		\$129.06					
61831	NAPA AUTO PARTS	JAC00037019654	06/02/2017	\$128.68		06/02/2017		R&R-Invoice	MUNICIPAL GARAGE
		PUBLIC SAFETY - POLICE		\$118.82					
		PUBLIC SAFETY - POLICE		\$5.08					
		PUBLIC SAFETY - POLICE		\$4.78					
61831	NAPA AUTO PARTS	JAC00037019644	06/02/2017	\$127.06		06/02/2017		R&R-Invoice	MUNICIPAL GARAGE
		PUBLIC WORKS		\$127.06					
63933	NORRAN RHONDA	062017	06/20/2017	\$127.50		06/27/2017		R&R-Invoice	OFFICIAL PAY
		PARKS & RECREATION		\$127.50					
71093	COMCAST	09577 412857-02-3/060917	06/09/2017	\$127.66		06/27/2017		R&R-Invoice	CABLE & INTERNET FOR TL LOVE
		HUMAN & CULTURAL SERVICES		\$127.66					CENTER 09577 412857-02-3
69374	WASHINGTON-AGEE MIHIA	061617	06/16/2017	\$125.36		06/27/2017		R&R-Invoice	DEATH BENEFITS 10J106WC001
		GENERAL GOVERNMENT		\$125.36					
69380	OWENS MELISSA	061617	06/16/2017	\$125.36		06/27/2017		R&R-Invoice	DEATH BENEFITS 10J106WC001
		GENERAL GOVERNMENT		\$125.36					
69381	THOMAS COURTNEY N	061617	06/16/2017	\$125.36		06/27/2017		R&R-Invoice	DEATH BENEFITS 10J106WC001
		GENERAL GOVERNMENT		\$125.36					
61831	NAPA AUTO PARTS	JAC00037019473	05/19/2017	\$124.63		05/19/2017		R&R-Invoice	MUNICIPAL GARAGE
		PUBLIC SAFETY - POLICE		\$79.48					
		PUBLIC SAFETY - POLICE		\$22.87					
		PUBLIC SAFETY - POLICE		\$1.59					
		PUBLIC SAFETY - POLICE		\$8.06					
61831	NAPA AUTO PARTS	JAC00037019623	06/01/2017	\$124.76		06/01/2017		R&R-Invoice	MUNICIPAL GARAGE
		PUBLIC SAFETY - POLICE		\$111.20					
		PUBLIC SAFETY - POLICE		\$13.56					
69953	INJURED WORKERS PHARMACY LLC	3144993/041217	04/12/2017	\$124.78		06/27/2017		R&R-Invoice	DEXTER SIMMONS 04/12/17
		GENERAL GOVERNMENT		\$124.78					
70422	ABC LOCK & KEY LLC	3551	02/09/2017	\$125.00		06/27/2017		Limited-PO	REKEY
		PUBLIC WORKS		\$125.00					
		REKEY TRUCK KEY FOR TK 656		\$125.00					
		REKEY TRUCK KEY FOR TK 565		1.000	Received	\$125.00			
63974	JOHNSON EDWARD	062017	06/19/2017	\$122.50		06/27/2017		R&R-Invoice	OFFICIAL PAY
		PARKS & RECREATION		\$122.50					
67973	THOMPSON ALBERTA	061217	06/12/2017	\$122.50		06/27/2017		R&R-Invoice	OFFICIAL PAY
		PARKS & RECREATION		\$122.50					
67973	THOMPSON ALBERTA	061917	06/19/2017	\$122.50		06/27/2017		R&R-Invoice	OFFICIAL PAY
		PARKS & RECREATION		\$122.50					
71173	ARMSTRONG SUNDARIA	061917	06/19/2017	\$122.50		06/27/2017		R&R-Invoice	OFFICIAL PAY

AP755 VENDOR PAYMENTS / FOR CLAIM DOCKET - 06/27/2017
 Report Title - AMOUNTS (DESCENDING) ALL TYPES
 Invoice Payments Under \$500

VEN#	VENDOR-NAME	INVOICE	INV-DATE	AMOUNT	AUTHORIZATION	DUE-DATE	REF-NUMBER	PAYMENT-TYPE	REMARKS
71953	TURNER TYLER	PARKS & RECREATION	06/12/2017	\$122.50		06/27/2017		R&R-Invoice	OFFICIAL PAY
71953	TURNER TYLER	PARKS & RECREATION	06/19/2017	\$122.50		06/27/2017		R&R-Invoice	OFFICIAL PAY
20377	ENTERGY	PARKS & RECREATION	06/27/2017	\$121.47		06/27/2017	92216001	UTILITY-PAYM	
	1 454006451	PLANNING & DEVELOPMENT		\$121.47					
	0+92215912	PLANNING & DEVELOPMENT						\$121.47	ELECTRIC LIGHT AND POWER
40789	CINTAS CORPORATION	PUBLIC WORKS	05/30/2017	\$120.61		06/27/2017		R&R-Invoice	UNIFORM RENTAL
40789	CINTAS CORPORATION	PUBLIC WORKS	06/06/2017	\$120.61		06/27/2017		R&R-Invoice	UNIFORM RENTAL
40789	CINTAS CORPORATION	PUBLIC WORKS	06/13/2017	\$120.61		06/27/2017		R&R-Invoice	UNIFORM RENTAL
61831	NAPA AUTO PARTS	JAC00037019684	06/05/2017	\$120.76		06/05/2017		R&R-Invoice	MUNICIPAL GARAGE
66021	CONCASR CABLE	PUBLIC SAFETY - POLICE	05/31/2017	\$120.63		06/27/2017		R&R-Invoice	09577 772011-01-2 CABLE SERVICES
20377	ENTERGY	PUBLIC SAFETY - POLICE	06/27/2017	\$120.00		06/27/2017	18291369	UTILITY-PAYM	
	5 504106451	PARKS & RECREATION		\$120.00					
	0+18279331	PARKS & RECREATION						\$120.00	ELECTRIC LIGHT AND POWER
61831	NAPA AUTO PARTS	JAC00037019593	05/30/2017	\$119.79		06/19/2017	0.1	R&R-Invoice	MUNICIPAL GARAGE
	1 442716316	PUBLIC SAFETY - POLICE		\$119.26				R&R-Invoice	
	1 442716316	PUBLIC SAFETY - POLICE		\$27.50				R&R-Invoice	
	1 442716316	PUBLIC SAFETY - POLICE		\$5.53				R&R-Invoice	
61831	NAPA AUTO PARTS	JAC00037019707	06/07/2017	\$118.71		06/07/2017		R&R-Invoice	MUNICIPAL GARAGE
	1 442406316	PUBLIC SAFETY - POLICE		\$61.17				R&R-Invoice	
	1 442406316	PUBLIC SAFETY - POLICE		\$57.54				R&R-Invoice	
20377	ENTERGY	PARKS & RECREATION	06/27/2017	\$117.98		06/27/2017	16669426	UTILITY-PAYM	
	5 504106451	PARKS & RECREATION		\$117.98					
	0+16669152	PARKS & RECREATION						\$117.98	ELECTRIC LIGHT AND POWER
61831	NAPA AUTO PARTS	JAC00037017825	01/05/2017	\$117.78		01/05/2017		R&R-Invoice	MUNICIPAL GARAGE
	1 442406316	PUBLIC SAFETY - POLICE		\$117.78				R&R-Invoice	
61831	NAPA AUTO PARTS	JAC00037019485	05/19/2017	\$117.78		05/19/2017		R&R-Invoice	MUNICIPAL GARAGE
	1 442406316	PUBLIC SAFETY - POLICE		\$117.78				R&R-Invoice	
61831	NAPA AUTO PARTS	JAC00037019490	05/19/2017	\$117.78		05/19/2017		R&R-Invoice	MUNICIPAL GARAGE
	1 442406316	PUBLIC SAFETY - POLICE		\$117.78				R&R-Invoice	
61831	NAPA AUTO PARTS	JAC00037019574	05/25/2017	\$117.78		05/25/2017		R&R-Invoice	MUNICIPAL GARAGE
	1 442406316	PUBLIC SAFETY - POLICE		\$117.78				R&R-Invoice	
60427	MIFCO IMPRESSION PRODUCTS INC	PUBLIC SAFETY - POLICE	06/01/2017	\$115.75		06/27/2017		R&R-Invoice	COPIER RENTAL

AP755 VENDOR PAYMENTS / FOR CLAIM DOCKET - 06/27/2017
 Report Title - AMOUNTS (DESCENDING) ALL TYPES
 Invoice Payments Under \$500

VEN#	VENDOR-NAME	INVOICE	INV-DATE	AMOUNT	AUTHORIZATION	DUE-DATE	REF-NUMBER	PAYMENT-TYPE	REMARKS
60427	MIPCO IMPRESSION PRODUCTS INC	PUBLIC WORKS	06/01/2017	\$115.75		06/27/2017		R&R-Invoice	COPIER RENTAL
31592	STATE OF MS UNMC	PUBLIC WORKS	04/17/2017	\$113.60		06/27/2017		R&R-Invoice	SIMONS DEXTER(14J-172WC)00
72629	RON TURLEY ASSOCIATES INC	GENERAL GOVERNMENT	06/02/2017	\$114.00		06/27/2017		R&R-Invoice	2000 STANDARD LABELS, RIBBONS
66746	SPANN ALEXANDER	PLANNING & DEVELOPMENT	06/12/2017	\$112.50		06/27/2017		R&R-Invoice	BAR CODE EQUIPMENT & SUPPLIES
61831	NAPA AUTO PARTS	PARKS & RECREATION	05/23/2017	\$111.20		05/23/2017		R&R-Invoice	MUNICIPAL GARAGE
61831	NAPA AUTO PARTS	PUBLIC SAFETY - POLICE	05/24/2017	\$111.45		05/24/2017		R&R-Invoice	MUNICIPAL GARAGE
61831	NAPA AUTO PARTS	PUBLIC SAFETY - POLICE	05/25/2017	\$111.20		05/25/2017		R&R-Invoice	MUNICIPAL GARAGE
61831	NAPA AUTO PARTS	PUBLIC SAFETY - POLICE	05/30/2017	\$111.55		05/30/2017		R&R-Invoice	MUNICIPAL GARAGE
61831	NAPA AUTO PARTS	PUBLIC SAFETY - POLICE	06/01/2017	\$111.20		06/01/2017		R&R-Invoice	MUNICIPAL GARAGE
61831	NAPA AUTO PARTS	PUBLIC SAFETY - POLICE	06/01/2017	\$111.20		06/01/2017		R&R-Invoice	MUNICIPAL GARAGE
61831	NAPA AUTO PARTS	PUBLIC SAFETY - POLICE	06/02/2017	\$111.20		06/02/2017		R&R-Invoice	MUNICIPAL GARAGE
61831	NAPA AUTO PARTS	PUBLIC SAFETY - POLICE	06/07/2017	\$111.20		06/07/2017		R&R-Invoice	MUNICIPAL GARAGE
61831	NAPA AUTO PARTS	PUBLIC SAFETY - POLICE	06/08/2017	\$111.35		06/08/2017		R&R-Invoice	MUNICIPAL GARAGE
20377	ENTERGY	PLANNING & DEVELOPMENT	06/27/2017	\$108.10		06/27/2017	16745846	UTILITY-PAYM	
20377	ENTERGY	PARKS & RECREATION	06/27/2017	\$108.57		06/27/2017		R&R-Invoice	ELECTRIC LIGHT AND POWER
61831	NAPA AUTO PARTS	PUBLIC WORKS	05/19/2017	\$106.82		06/19/2017	0.1	\$106.91	ELECTRIC LIGHT AND POWER
61831	NAPA AUTO PARTS	PUBLIC WORKS	05/19/2017	\$102.74		05/19/2017		R&R-Invoice	MUNICIPAL GARAGE
61831	NAPA AUTO PARTS	PUBLIC WORKS	05/19/2017	\$27.00					
61831	NAPA AUTO PARTS	PUBLIC WORKS	05/19/2017	\$27.00-					

AP755
 VENDOR PAYMENTS / FOR CLAIM DOCKET - 06/27/2017
 Report Title - AMOUNTS (DESCENDING) ALL TYPES
 Invoice Payments Under \$500

VEN#	VENDOR-NAME	INVOICE	INV-DATE	AMOUNT	AUTHORIZATION	DUE-DATE	REF-NUMBER	PAYMENT-TYPE	REMARKS
20225	ATMOS ENERGY	PUBLIC WORKS	06/27/2017	\$4.08					
	1 451106316	1276452758		\$105.97					
	1 441706453	FIRE DEPARTMENT		\$105.97					
	0+3012764527	FIRE DEPARTMENT					0.1	\$105.97	GAS
71093	COMCAST	09577 369896-02-5	06/07/2017	\$105.19					
	1 434206419	HUMAN & CULTURAL SERVICES		\$105.19					
60427	MIPCO IMPRESSION PRODUCTS INC	131820	06/01/2017	\$101.41					
	31 520106514	PUBLIC WORKS		\$101.41					
20377	ENERGY	\116434689	06/27/2017	\$100.43					
	31 520106451	PUBLIC WORKS		\$100.43					
67981	INNOVATIVE STAFFING SERVICES	3725	06/12/2017	\$100.80					
	1 415106489	ADMINISTRATION		\$100.80					
61831	NAPA AUTO PARTS	JACO0037019536	05/23/2017	\$99.90					
	1 442406316	PUBLIC SAFETY - POLICE		\$85.29					
	1 442406316	PUBLIC SAFETY - POLICE		\$14.61					
70646	MCHRIDE EDDIE L	06092017	06/09/2017	\$100.00					
	1 402206419	GENERAL GOVERNMENT		\$100.00					
71046	SANDERS SHANTA	06092017	06/09/2017	\$100.00					
	1 402206419	GENERAL GOVERNMENT		\$100.00					
72452	STEVENS LEO	060917	06/09/2017	\$100.00					
	1 402206419	GENERAL GOVERNMENT		\$100.00					
72622	JOHNSON CHERYL B	06062017	06/06/2017	\$100.00					
	1 402206419	GENERAL GOVERNMENT		\$100.00					
72631	JORDEN KIMBERLY	060617	06/06/2017	\$100.00					
	1 402206419	GENERAL GOVERNMENT		\$100.00					
B1963	Old River Homes ,	017052200	05/22/2017	\$100.00					
	30 2108	Liabilities		\$100.00					
B1970	KNIGHT TIGAH ,	017052200	05/22/2017	\$100.00					
	30 2108	Liabilities		\$100.00					
B1989	GRAHAM CHRISTOPHER B ,	017052400	05/24/2017	\$100.00					
	30 2108	Liabilities		\$100.00					
B1992	BISWAS LISA	06122017	06/12/2017	\$100.00					
	30 2325	Liabilities		\$100.00					
B1994	BROWN TEDRICE	06072017	06/07/2017	\$100.00					
	30 2325	Liabilities		\$100.00					
B1998	WOODARD WILLIAM	11052	06/01/2017	\$100.00					
	18 518206722	GENERAL GOVERNMENT		\$100.00					
B2000	BELL TYRE	10722	06/08/2017	\$100.00					
	18 518206722	GENERAL GOVERNMENT		\$100.00					
20225	ATMOS ENERGY	1279787758	06/27/2017	\$98.36					

06/27/2017 3012724356 UTILITY-PAYM

VENDOR PAYMENTS / FOR CLAIM DOCKET - 06/27/2017
 Report Title - AMOUNTS (DESCENDING) ALL TYPES
 Invoice Payments Under \$500

VEN#	VENDOR-NAME	INVOICE	INV-DATE	AMOUNT	AUTHORIZATION	DUE-DATE	REF-NUMBER	PAYMENT-TYPE	REMARKS
40789	CINTAS CORPORATION	FIRE DEPARTMENT	05/30/2017	\$98.90		06/21/2017	0.1	\$98.36	GAS
40789	CINTAS CORPORATION	PUBLIC WORKS	06/06/2017	\$98.90		06/21/2017			UNIFORM RENTAL
40789	CINTAS CORPORATION	PUBLIC WORKS	06/06/2017	\$98.90		06/21/2017			UNIFORM RENTAL
71230	NEWSOUTH NEUROSPINE LP400	GENERAL GOVERNMENT	04/12/2017	\$98.28		06/21/2017			STEVE L MCDONALD
20377	ENTERGY	PLANNING & DEVELOPMENT	06/27/2017	\$97.90		06/21/2017	19832625		UTILITY-PAYM
68366	DIXON HERBERT	PLANNING & DEVELOPMENT	06/12/2017	\$97.50		06/19/2017	0.1	\$97.90	ELECTRIC LIGHT AND POWER
68366	DIXON HERBERT	RECREATION	06/12/2017	\$97.50		06/27/2017			OFFICIAL PAY
68366	DIXON HERBERT	RECREATION	06/19/2017	\$97.50		06/27/2017			OFFICIAL PAY
71833	WADE JOSHUAUNDA	RECREATION	06/12/2017	\$97.50		06/21/2017			OFFICIAL PAY
71833	WADE JOSHUAUNDA	RECREATION	06/19/2017	\$97.50		06/27/2017			OFFICIAL PAY
40789	CINTAS CORPORATION	RECREATION	06/06/2017	\$96.55		06/21/2017			UNIFORM RENTAL
68267	UNIVERSITY PHYSICIANS	GENERAL GOVERNMENT	03/08/2017	\$96.64		06/27/2017			SMITH MIRON B(17J-33-WC)00
61831	NAPA AUTO PARTS	JAC00037019580	05/25/2017	\$95.13		05/25/2017			MUNICIPAL GARAGE
20377	ENTERGY	PUBLIC WORKS	06/27/2017	\$94.60		06/27/2017	16664898		UTILITY-PAYM
20225	ATMOS ENERGY	PUBLIC WORKS	06/27/2017	\$93.61		06/27/2017	3012724356	\$94.60	ELECTRIC LIGHT AND POWER
20225	ATMOS ENERGY	FIRE DEPARTMENT	06/27/2017	\$93.61		06/27/2017	3012724356		UTILITY-PAYM
40789	CINTAS CORPORATION	FIRE DEPARTMENT	06/06/2017	\$93.69		06/21/2017	0.1	\$93.61	GAS
54148	CAPITAL ORTHOPAEDIC CLINIC	GENERAL GOVERNMENT	04/14/2017	\$93.79		06/27/2017			ATKINSON LAWRENCE(13J-51-WC)00
54148	CAPITAL ORTHOPAEDIC CLINIC	GENERAL GOVERNMENT	04/19/2017	\$93.79		06/27/2017			FALCON BRANDON J(17J-37-WC)00
61831	NAPA AUTO PARTS	JAC00037019723	06/07/2017	\$93.69		06/07/2017			MUNICIPAL GARAGE

AP755 VENDOR PAYMENTS / FOR CLAIM DOCKET - 06/27/2017
 Report Title - AMOUNTS (DESCENDING) ALL TYPES
 Invoice Payments Under \$500

VEN#	VENDOR-NAME	INVOICE	INV-DATE	AMOUNT	AUTHORIZATION	DUE-DATE	REF-NUMBER	PAYMENT-TYPE	REMARKS
69272	COMPREHENSIVE PAIN CENTER OF	PUBLIC SAFETY - POLICE	05/01/2017	\$93.79		06/27/2017		R&R-Invoice	ATKINSON LAWRENCE(13J-51-WC)00
	1 407926481	GENERAL GOVERNMENT		\$93.79					050117
71230	NEWSOUTH NEUROSPINE LP400	GENERAL GOVERNMENT	04/13/2017	\$93.79		06/27/2017		R&R-Invoice	LEWIS E NOTTALL 04/13/17
	1 407926481	GENERAL GOVERNMENT		\$93.79					
20377	ENERGY	PUBLIC WORKS	06/27/2017	\$92.20		06/27/2017	198180	UTILITY-PAYM	
	31 522406451	PUBLIC WORKS		\$92.20					
	0+19816537	PUBLIC WORKS		\$89.25		06/19/2017	0.1	\$92.20	ELECTRIC LIGHT AND POWER
40789	CINTAS CORPORATION	PUBLIC WORKS	05/23/2017	\$89.25		06/27/2017		R&R-Invoice	UNIFORM RENTAL
	1 456106217	PUBLIC WORKS		\$89.25					
61831	NAPA AUTO PARTS	JAC00037019515	05/22/2017	\$89.10		05/22/2017		R&R-Invoice	MUNICIPAL GARAGE
	1 441206316	FIRE DEPARTMENT		\$9.94					
	1 441206316	FIRE DEPARTMENT		\$15.53					
	1 441206316	FIRE DEPARTMENT		\$5.00					
	1 441206316	FIRE DEPARTMENT		\$8.83					
	1 441206316	FIRE DEPARTMENT		\$33.28					
	1 441206316	FIRE DEPARTMENT		\$1.22					
	1 441206316	FIRE DEPARTMENT		\$1.88					
	1 441206316	FIRE DEPARTMENT		\$2.54					
	1 441206316	FIRE DEPARTMENT		\$10.88					
61831	NAPA AUTO PARTS	JAC00037019532	05/22/2017	\$88.53		05/22/2017		R&R-Invoice	MUNICIPAL GARAGE
	1 451256316	PUBLIC WORKS		\$88.53					
61831	NAPA AUTO PARTS	JAC00037019711	06/07/2017	\$88.53		06/07/2017		R&R-Invoice	MUNICIPAL GARAGE
	1 451246316	PUBLIC WORKS		\$88.53					
61831	NAPA AUTO PARTS	JAC00037018377	02/23/2017	\$87.30		02/23/2017		R&R-Invoice	MUNICIPAL GARAGE
	1 444606316	PLANNING & DEVELOPMENT		\$36.30					
	1 444606316	PLANNING & DEVELOPMENT		\$5.38					
	1 444606316	PLANNING & DEVELOPMENT		\$4.26					
	1 444606316	PLANNING & DEVELOPMENT		\$41.36					
72621	ADAMS CHANDRA	061217	06/12/2017	\$87.50		06/27/2017		R&R-Invoice	OFFICIAL PAY
	5 501266419	PARKS & RECREATION		\$87.50					
81968	GARRETSON ROLAND	017052200	05/22/2017	\$87.20		06/27/2017		R&R-Invoice	WATER REFUND ACC
	30 2108	Liabilities		\$87.20					
31592	STATE OF MS UMMC	H160175545701	12/07/2016	\$86.59		06/27/2017		R&R-Invoice	SOSNOSKIE ROBERT(16J-187-WC)00
	1 407926481	GENERAL GOVERNMENT		\$86.59					120716
31592	STATE OF MS UMMC	H160177553501	12/21/2016	\$86.59		06/27/2017		R&R-Invoice	SOSNOSKIE ROBERT(16J-187-WC)00
	1 407926481	GENERAL GOVERNMENT		\$86.59					122116
31592	STATE OF MS UMMC	H160179697401	01/11/2017	\$86.59		06/27/2017		R&R-Invoice	SOSNOSKIE ROBERT(16J-187-WC)00
	1 407926481	GENERAL GOVERNMENT		\$86.59					011117

VENDOR PAYMENTS / FOR CLAIM DOCKET - 06/27/2017
 Report Title - AMOUNTS (DESCENDING) ALL TYPES
 Invoice Payments Under \$500

VEN#	VENDOR-NAME	INVOICE	INV-DATE	AMOUNT	AUTHORIZATION	DUE-DATE	REF-NUMBER	PAYMENT-TYPE	REMARKS
31592	STATE OF MS UMC	H160185601101	02/22/2017	\$86.59		06/27/2017		R&R-Invoice	SOSNOSKIE ROBERT(16J-187-WC)00
40789	CINTAS CORPORATION	GENERAL GOVERNMENT		\$86.59					022217
		210348884	06/06/2017	\$86.49		06/27/2017		R&R-Invoice	UNIFORM RENTAL
		PLANNING & DEVELOPMENT		\$86.49					
61831	NAPA AUTO PARTS	JAC00037019571	05/25/2017	\$86.63		05/25/2017		R&R-Invoice	MUNICIPAL GARAGE
		PUBLIC SAFETY - POLICE		\$86.63					
		PUBLIC SAFETY - POLICE		\$18.00					
		PUBLIC SAFETY - POLICE		\$18.00					
61831	NAPA AUTO PARTS	JAC00037019600	05/30/2017	\$86.63		05/30/2017		R&R-Invoice	MUNICIPAL GARAGE
		PUBLIC SAFETY - POLICE		\$86.63					
		PUBLIC WORKS		\$18.00					
		PUBLIC WORKS		\$18.00					
61831	NAPA AUTO PARTS	JAC00037019700	06/06/2017	\$86.63		06/06/2017		R&R-Invoice	MUNICIPAL GARAGE
		PUBLIC SAFETY - POLICE		\$86.63					
		PUBLIC SAFETY - POLICE		\$18.00					
		PUBLIC SAFETY - POLICE		\$18.00					
20225	ATMOS ENERGY	1287955658	06/27/2017	\$85.06		06/27/2017	3012724356	UTILITY-PAYM	
		FIRE DEPARTMENT		\$85.06					
20377	ENTERGY	19833300\	06/27/2017	\$85.85		06/21/2017	0.1	\$85.06	GAS
		PUBLIC SAFETY - POLICE		\$85.85		06/27/2017	19833508	UTILITY-PAYM	
40789	CINTAS CORPORATION	210345861	05/30/2017	\$85.07		06/19/2017	0.1	\$85.85	ELECTRIC LIGHT AND POWER
		PUBLIC WORKS		\$85.07		06/27/2017		R&R-Invoice	UNIFORM RENTAL
40789	CINTAS CORPORATION	210348872	06/06/2017	\$85.07		06/27/2017		R&R-Invoice	UNIFORM RENTAL
		PUBLIC WORKS		\$85.07					
71093	COMCAST	09577 417060-01-9/061317	06/13/2017	\$85.95		06/27/2017		R&R-Invoice	CABLE & INTERNET SERVICE FOR
		HUMAN & CULTURAL SERVICES		\$85.95					CHAMPION SENIOR CENTER
68976	STONERIVER	44284325	04/04/2017	\$85.00		06/27/2017		R&R-Invoice	GEORGIA MACKLIN 04/04/17
		GENERAL GOVERNMENT		\$85.00					
70072	OFFICE DEPOT #414	921901675001	04/20/2017	\$83.89		06/27/2017		Regular-PO	FILE MESH WALL HNG 3PK BK
		PUBLIC WORKS		\$83.89					ACCUSTAMP 2CL FILE
				\$83.89					PEN B2P BLPT RCYLD FN DZ
	PJ 829 OFFICE SUPPLIES			\$83.89					
	001	QUOTE---891801 3-PK HANGING WA		1.000	Received	\$48.33			
	002	330885 1-COLOER STAMPS		1.000	Received	\$11.49			
	003	724942 FLASH DRIVE		1.000	Received	\$12.08			
	004	463142 BALLPOINT PENS		1.000	Received	\$11.99			
B1974	SCOTT IIII ANDREY D ,	017052300	05/23/2017	\$83.99		06/27/2017		R&R-Invoice	WATER REFUND ACC 81799894
	30 2108	Liabilities		\$83.99					
68997	WADE SYLVIA	061217	06/12/2017	\$82.50		06/27/2017		R&R-Invoice	OFFICIAL PAY
	5 501266419	PARKS & RECREATION		\$82.50					

AP755
 VENDOR PAYMENTS / FOR CLAIM DOCKET - 06/27/2017
 Report Title - AMOUNTS (DESCENDING) ALL TYPES
 Invoice Payments Under \$500

VEN#	VENDOR-NAME	INVOICE	INV-DATE	AMOUNT	AUTHORIZATION	DUE-DATE	REF-NUMBER	PAYMENT-TYPE	REMARKS
68997	WADE SYLVIA	061917	06/19/2017	\$82.50		06/27/2017		R&R-Invoice	OFFICIAL PAY
	5 501266419	PARKS & RECREATION		\$82.50					
70683	WILLIAMS TAMERA D	061217	06/12/2017	\$82.50		06/27/2017		R&R-Invoice	OFFICIAL PAY
	5 501266419	PARKS & RECREATION		\$82.50					
20225	ATMOS ENERGY	1291898758	06/27/2017	\$81.25		06/27/2017	3012724356	UTILITY-PAYM	
	1 441706453	FIRE DEPARTMENT		\$81.25					
	0+3012918987	FIRE DEPARTMENT				06/21/2017		\$81.25	GAS
47085	STUART C IRBY CO	S010200704.001	05/24/2017	\$81.84		06/27/2017		Limited-PO	SYLV 67500 LU35/MED CLR B17
	5 504306299	PARKS & RECREATION		\$81.84					MED HPS LAMP
	LJ 1677 Sunny Guy			\$81.84					
	001	SYLV 67500 LU35/Med CLR B17MED		4.000	Invoiced				
B1972	LARRY PHYLLICIA L ,	017052300	05/23/2017	\$81.50		06/27/2017		R&R-Invoice	WATER REFUND ACC 33040007
	30 2108	Liabilities		\$81.50					
40789	CINTAS CORPORATION	210348879	06/06/2017	\$79.91		06/21/2017		R&R-Invoice	UNIFORM RENTAL
	31 520206516	PUBLIC WORKS		\$79.91					
20377	ENERGY	85449734\	06/27/2017	\$78.16		06/27/2017	90034794	UTILITY-PAYM	
	1 442446451	PUBLIC SAFETY - POLICE		\$78.16					
	0+85449734	PUBLIC SAFETY - POLICE				06/19/2017		\$78.16	ELECTRIC LIGHT AND POWER
68267	UNIVERSITY PHYSICIANS	164617210	10/01/2016	\$78.12		06/27/2017		R&R-Invoice	SHORT KENNETH O(17J-31WC)00
	1 407926481	GENERAL GOVERNMENT		\$78.12					030816
60856	CITIBANK N A	5970995	05/08/2017	\$77.81		06/27/2017		Limited-PO	WLL PATCHES
	1 453006461	PUBLIC WORKS		\$77.81					
	LJ 1540 BLDG MAINT			\$77.81					
	001	WALL PROTECT IVORY		2.000	Invoiced			\$5.94	
	002	WALL PROTECT WHITE		3.000	Invoiced			\$8.91	
	003	ALUM STEP LADDER		1.000	Invoiced			\$62.96	
61831	NAPA AUTO PARTS	JAC00037018683	03/21/2017	\$77.64		03/21/2017		R&R-Invoice	MUNICIPAL GARAGE
	1 407856316	GENERAL GOVERNMENT		\$72.89					
	1 407856316	GENERAL GOVERNMENT		\$18.00					
	1 407856316	GENERAL GOVERNMENT		\$18.00-					
	1 407856316	GENERAL GOVERNMENT		\$4.75					
42781	DIGITEC CORPORATION	5817	05/30/2017	\$77.00		06/27/2017		R&R-Invoice	24" CUTER KNIVES SHARPENED(2) AND SHIPPED
	1 405006514	ADMINISTRATION		\$77.00					
61831	NAPA AUTO PARTS	JAC00037019525	05/22/2017	\$76.48		05/22/2017		R&R-Invoice	MUNICIPAL GARAGE
	31 522206316	PUBLIC WORKS		\$75.34					
	31 522206316	PUBLIC WORKS		\$1.14					
61831	NAPA AUTO PARTS	JAC00037019562	05/24/2017	\$76.61		05/24/2017		R&R-Invoice	MUNICIPAL GARAGE
	31 521406316	PUBLIC WORKS		\$31.06					
	31 521406316	PUBLIC WORKS		\$40.47					
	31 521406316	PUBLIC WORKS		\$9.00					
	31 521406316	PUBLIC WORKS		\$9.00-					
	31 521406316	PUBLIC WORKS		\$5.08					

AP755
 VENDOR PAYMENTS / FOR CLAIM DOCKET - 06/27/2017
 Report Title - AMOUNTS (DESCENDING) ALL TYPES
 Invoice Payments Under \$500

VEN#	VENDOR-NAME	INVOICE	INV-DATE	AMOUNT	AUTHORIZATION	DUE-DATE	REF-NUMBER	PAYMENT-TYPE	REMARKS
B1958	GARRETT ROBINIA R , 30 2108	017052200 Liabilities	05/22/2017	\$76.99		06/27/2017		R&R-Invoice	WATER REFUND ACC 85390654
20225	ATMOS ENERGY 1 441706453	1291868358 FIRE DEPARTMENT	06/27/2017	\$75.55		06/27/2017	3012724356	UTILITY-PAYM	
	0+3012918683 30 2108	017052400 Liabilities	05/24/2017	\$75.56		06/27/2017		R&R-Invoice	WATER REFUND ACC 64242000
B1999	EVERETT RENEE 18 518206722	10988 GENERAL GOVERNMENT	06/01/2017	\$75.00		06/27/2017		R&R-Invoice	FULL & COMPLETE SETTLEMENT
61831	NAPA AUTO PARTS 9 506106316	JAC00037019658 PUBLIC WORKS	06/02/2017	\$73.12		06/02/2017		R&R-Invoice	MUNICIPAL GARAGE
B1965	RED LION INN , 30 2108	017052200 Liabilities	05/22/2017	\$73.18		06/27/2017		R&R-Invoice	WATER REFUND ACC 78170000
31330	AIRGAS USA LLC 1 441606299	9945247041 FIRE DEPARTMENT	05/31/2017	\$72.44		06/27/2017		R&R-Invoice	CYLINDER RENTAL
61831	NAPA AUTO PARTS 9 506106316	JAC00037019578 PUBLIC WORKS	05/25/2017	\$72.45		05/25/2017		R&R-Invoice	MUNICIPAL GARAGE
	9 506106316	PUBLIC WORKS		\$28.72					
	9 506106316	PUBLIC WORKS		\$10.33					
	9 506106316	PUBLIC WORKS		\$1.53					
	9 506106316	PUBLIC WORKS		\$1.01					
	9 506106316	PUBLIC WORKS		\$16.88					
	9 506106316	PUBLIC WORKS		\$13.98					
61831	NAPA AUTO PARTS 1 451256316	JAC00037019611 PUBLIC WORKS	06/01/2017	\$72.02		06/01/2017		R&R-Invoice	MUNICIPAL GARAGE
	1 451256316	PUBLIC WORKS		\$11.12					
	1 451256316	PUBLIC WORKS		\$17.99					
	1 451256316	PUBLIC WORKS		\$5.21					
	1 451256316	PUBLIC WORKS		\$21.17					
	1 451256316	PUBLIC WORKS		\$7.50					
	1 451256316	PUBLIC WORKS		\$4.60					
	1 451256316	PUBLIC WORKS		\$4.43					
68976	STONERIVER 1 407926212	44337545 GENERAL GOVERNMENT	04/24/2017	\$72.41		06/27/2017		R&R-Invoice	SAM SANDIFER 04/24/17
71711	WEST KENNETH 5 501256419	061317 PARKS & RECREATION	06/13/2017	\$72.00		06/27/2017		Regular-PO	SECURITY SERVICES
	PJ 914 Security at Thalia Mara Hall/All City Dance Recital 001	(Quote) Security Guard Service		\$72.00					
61831	NAPA AUTO PARTS 1 444606316	JAC00037018679 PLANNING & DEVELOPMENT	03/21/2017	\$70.83		03/21/2017		R&R-Invoice	MUNICIPAL GARAGE
	1 444606316	PLANNING & DEVELOPMENT		\$52.83					
	1 444606316	PLANNING & DEVELOPMENT		\$36.00					
	1 444606316	PLANNING & DEVELOPMENT		\$5.53					
	1 444606316	PLANNING & DEVELOPMENT		\$36.00-					
	1 444606316	PLANNING & DEVELOPMENT		\$7.74					

AP755
 VENDOR PAYMENTS / FOR CLAIM DOCKET - 06/27/2017
 Report Title - AMOUNTS (DESCENDING) ALL TYPES
 Invoice Payments Under \$500

VEN#	VENDOR-NAME	INVOICE	INV-DATE	AMOUNT	AUTHORIZATION	DUE-DATE	REF-NUMBER	PAYMENT-TYPE	REMARKS
61831	NAPA AUTO PARTS	PLANNING & DEVELOPMENT	05/25/2017	\$9.20					
61831	NAPA AUTO PARTS	PLANNING & DEVELOPMENT	05/25/2017	\$9.20					
61831	NAPA AUTO PARTS	JAC00037019577	05/25/2017	\$70.64				R&R-Invoice	MUNICIPAL GARAGE
61831	NAPA AUTO PARTS	PUBLIC WORKS	06/02/2017	\$70.64				R&R-Invoice	MUNICIPAL GARAGE
61831	NAPA AUTO PARTS	JAC00037019646	06/02/2017	\$70.74				R&R-Invoice	MUNICIPAL GARAGE
61831	NAPA AUTO PARTS	PUBLIC WORKS	06/08/2017	\$60.48				R&R-Invoice	MUNICIPAL GARAGE
61831	NAPA AUTO PARTS	PUBLIC WORKS	06/08/2017	\$10.26				R&R-Invoice	MUNICIPAL GARAGE
10781	MARS & STEEL TROPHIES	JAC00037019727	06/08/2017	\$70.64				R&R-Invoice	MUNICIPAL GARAGE
10781	MARS & STEEL TROPHIES	PUBLIC WORKS	05/30/2017	\$70.64				Regular-PO	PLATES 9X6 SILVER/BLACK LASER ENGRAVING
10781	MARS & STEEL TROPHIES	HUMAN & CULTURAL SERVICES	05/30/2017	\$69.50				Regular-PO	PLATES 9X5 ENGRAVING REVERSE OVERLAY/NO BOARD
10781	MARS & STEEL TROPHIES	HUMAN & CULTURAL SERVICES	05/30/2017	\$69.50				Regular-PO	PLATES 9X5 ENGRAVING REVERSE OVERLAY/NO BOARD
PJ	1115 PLATES FOR SMITH ROBERTSON MUSEUM			\$69.50					
60586	C NO BUG PEST CONTROL	9X6 SILVER/BLACK PLATES	06/12/2017	1.000	Received	\$27.00		R&R-Invoice	PEST SERVICE
60586	C NO BUG PEST CONTROL	9X5 SILVER/BLACK PLATE	06/12/2017	1.000	Received	\$22.50		R&R-Invoice	OFFICIAL PAY
60586	C NO BUG PEST CONTROL	ENGRAVING	06/12/2017	2.000	Received	\$20.00		R&R-Invoice	OFFICIAL PAY
63976	MAGEE BRENDA	PUBLIC WORKS	06/12/2017	\$70.00				R&R-Invoice	OFFICIAL PAY
63976	MAGEE BRENDA	PARKS & RECREATION	06/12/2017	\$70.00				R&R-Invoice	OFFICIAL PAY
68680	HARBER SANDRA ANITTA	PARKS & RECREATION	06/09/2017	\$70.00				R&R-Invoice	OFFICIAL PAY
68680	HARBER SANDRA ANITTA	PARKS & RECREATION	06/09/2017	\$70.00				R&R-Invoice	OFFICIAL PAY
69247	GRAY V L	PARKS & RECREATION	06/20/2017	\$70.00				R&R-Invoice	OFFICIAL PAY
69247	GRAY V L	PARKS & RECREATION	06/20/2017	\$70.00				R&R-Invoice	OFFICIAL PAY
69878	JACKSON LIFESTIGNS	PARKS & RECREATION	05/04/2017	\$70.00				R&R-Invoice	OFFICIAL PAY
69878	JACKSON LIFESTIGNS	HUMAN & CULTURAL SERVICES	05/04/2017	\$70.00				R&R-Invoice	OFFICIAL PAY
71087	JEMERSON STANLEY	PARKS & RECREATION	06/09/2017	\$70.00				R&R-Invoice	OFFICIAL PAY
71087	JEMERSON STANLEY	PARKS & RECREATION	06/09/2017	\$70.00				R&R-Invoice	OFFICIAL PAY
71087	JEMERSON STANLEY	PARKS & RECREATION	06/20/2017	\$70.00				R&R-Invoice	OFFICIAL PAY
71087	JEMERSON STANLEY	PARKS & RECREATION	06/20/2017	\$70.00				R&R-Invoice	OFFICIAL PAY
20225	ATMOS ENERGY	PARKS & RECREATION	06/27/2017	\$70.00				R&R-Invoice	OFFICIAL PAY
20225	ATMOS ENERGY	PARKS & RECREATION	06/27/2017	\$68.89				R&R-Invoice	OFFICIAL PAY
20377	ENERGERY	PUBLIC WORKS	06/27/2017	\$68.89				UTILITY-PAYM	
20377	ENERGERY	PUBLIC WORKS	06/27/2017	\$68.89				UTILITY-PAYM	
61831	NAPA AUTO PARTS	PLANNING & DEVELOPMENT	06/21/2017	\$68.18				R&R-Invoice	GAS
61831	NAPA AUTO PARTS	PLANNING & DEVELOPMENT	06/21/2017	\$68.18				R&R-Invoice	GAS
61831	NAPA AUTO PARTS	JAC00037019649	06/02/2017	\$68.90				R&R-Invoice	MUNICIPAL GARAGE
61831	NAPA AUTO PARTS	PUBLIC WORKS	06/02/2017	\$22.23				R&R-Invoice	MUNICIPAL GARAGE
61831	NAPA AUTO PARTS	PUBLIC WORKS	06/02/2017	\$46.67				R&R-Invoice	MUNICIPAL GARAGE
40432	AIRGAS USA INC	PUBLIC WORKS	10/01/2016	\$67.96				R&R-Invoice	CYLINDER RENTAL
40432	AIRGAS USA INC	PUBLIC WORKS	10/01/2016	\$67.96				R&R-Invoice	CYLINDER RENTAL
61831	NAPA AUTO PARTS	FIRE DEPARTMENT	06/01/2017	\$67.13				R&R-Invoice	MUNICIPAL GARAGE
61831	NAPA AUTO PARTS	JAC00037019624	06/01/2017	\$67.13				R&R-Invoice	MUNICIPAL GARAGE
61831	NAPA AUTO PARTS	PARKS & RECREATION	06/01/2017	\$67.13				R&R-Invoice	MUNICIPAL GARAGE
61831	NAPA AUTO PARTS	PARKS & RECREATION	06/01/2017	\$67.13				R&R-Invoice	MUNICIPAL GARAGE

AP755 VENDOR PAYMENTS / FOR CLAIM DOCKET - 06/27/2017
 Report Title - AMOUNTS (DESCENDING) ALL TYPES
 Invoice Payments Under \$500

VEN#	VENDOR-NAME	INVOICE	INV-DATE	AMOUNT	AUTHORIZATION	DUE-DATE	REF-NUMBER	PAYMENT-TYPE	REMARKS
61831	NAPA AUTO PARTS	JAC00037019712	06/07/2017	\$67.24		06/07/2017		R&R-Invoice	MUNICIPAL GARAGE
	9 506106316	PUBLIC WORKS		\$67.24					
63933	NORMAN RHONDA	061217	06/12/2017	\$67.50		06/27/2017		R&R-Invoice	OFFICIAL PAY
	5 501266419	PARKS & RECREATION		\$67.50				Regular-PO	BLACK TONER
69165	LD PRODUCTS DBA 4INKJETS	SIP006245267	05/08/2017	\$67.95		06/27/2017			
	1 406106219	ADMINISTRATION		\$67.95					
	PJ 983 PRINT CARTRIDGES FOR INFORMATION SYSTEMS			\$67.95					
	001 Q--COMP HP 283X/083X BLACK TON			2.000	Received	\$31.98			
	002 COMP 78A/CE278A TONER; #CE278A			3.000	Received	\$35.97			
70440	WEBB RUTHIE	061217	06/12/2017	\$67.50		06/27/2017		R&R-Invoice	OFFICIAL PAY
	5 501266419	PARKS & RECREATION		\$67.50					
61831	NAPA AUTO PARTS	JAC00037018386	02/23/2017	\$66.95		02/23/2017		R&R-Invoice	MUNICIPAL GARAGE
	31 522156316	PUBLIC WORKS		\$66.95					
71362	FISERV INC	91097294	06/14/2017	\$66.60		06/27/2017		R&R-Invoice	RETURNED ACH FEES
	31 520106419	PUBLIC WORKS		\$66.60					
20225	ATMOS ENERGY	1276402758	06/27/2017	\$65.10		06/27/2017	3012724356	UTILITY-PAYM	
	1 441706453	FIRE DEPARTMENT		\$65.10					
	0+3012764027	FIRE DEPARTMENT							
69953	INJURED WORKERS PHARMACY LLC	3248245	04/24/2017	\$64.16		06/21/2017	0.1	\$65.10 GAS	
	1 407926212	GENERAL GOVERNMENT		\$64.16				R&R-Invoice	DEXTER SIMMONS
61954	KRR PROPERTIES LLC	017052200	05/22/2017	\$64.47		06/27/2017		R&R-Invoice	WATER REFUND ACC
	30 2108	Liabilities		\$64.47					
61977	HUSBAND JR WAGNREN	017052300	05/23/2017	\$64.65		06/27/2017		R&R-Invoice	WATER REFUND ACC
	30 2108	Liabilities		\$64.65					
40789	CINTAS CORPORATION	210345873	05/30/2017	\$63.17		06/27/2017		R&R-Invoice	UNIFORM RENTAL
	1 444106516	PLANNING & DEVELOPMENT		\$63.17					
68267	UNIVERSITY PHYSICIANS	164678350/030817	03/08/2017	\$63.51		06/27/2017		R&R-Invoice	SMITH MIRON B(17J-33-WC)00
	1 407926481	GENERAL GOVERNMENT		\$63.51					
20225	ATMOS ENERGY	1276282758	06/27/2017	\$62.27		06/27/2017	3012724356	UTILITY-PAYM	
	1 453006453	PUBLIC WORKS		\$62.27					
	0+3012762627	PUBLIC WORKS							
61831	NAPA AUTO PARTS	JAC00037019653	06/02/2017	\$62.66		06/21/2017	0.1	\$62.27 GAS	
	1 456106316	PUBLIC WORKS		\$3.60				R&R-Invoice	MUNICIPAL GARAGE
	1 456106316	PUBLIC WORKS		\$36.48					
	1 456106316	PUBLIC WORKS		\$9.92					
	1 456106316	PUBLIC WORKS		\$4.60					
	1 456106316	PUBLIC WORKS		\$8.06					
40789	CINTAS CORPORATION	210342876	05/23/2017	\$60.29		06/27/2017		R&R-Invoice	UNIFORM RENTAL
	1 461306516	PUBLIC WORKS		\$60.29					
61976	HANCOCK JOSHUA D	017052300	05/23/2017	\$60.36		06/27/2017		R&R-Invoice	WATER REFUND ACC
	30 2108	Liabilities		\$60.36					
61982	MCNEELY DEBORA H	017052400	05/24/2017	\$60.35		06/27/2017		R&R-Invoice	WATER REFUND ACC

AP755 VENDOR PAYMENTS / FOR CLAIM DOCKET - 06/27/2017
 Report Title - AMOUNTS (DESCENDING) ALL TYPES
 Invoice Payments Under \$500

VEN#	VENDOR-NAME	INVOICE	INV-DATE	AMOUNT	AUTHORIZATION	DUE-DATE	REF-NUMBER	PAYMENT-TYPE	REMARKS
15280	SHERWIN WILLIAMS #7308	Liabilities 0012-0	05/23/2017	\$59.88		06/27/2017		Limited-PO	SUPERMAXX FLAT BLACK
	LJ 1671 Smith Rob. Museum	HUMAN & CULTURAL SERVICES		\$59.88					
	001	1006-35994 Each K8970000 Super		\$59.88	Invoiced	\$59.88			
61831	NAPA AUTO PARTS	JAC00037019722	06/07/2017	\$59.45		06/07/2017		R&R-Invoice	MUNICIPAL GARAGE
	1 442406316	PUBLIC SAFETY - POLICE		\$59.45					
61831	NAPA AUTO PARTS	JAC00037019587	05/30/2017	\$58.78		05/30/2017		R&R-Invoice	MUNICIPAL GARAGE
	31 522206316	PUBLIC WORKS		\$58.78					
B1956	HOLIDAY JOSEPHINE D ,	017052200	05/22/2017	\$58.16		06/27/2017		R&R-Invoice	WATER REFUND ACC 18520706
	30 2108	Liabilities		\$58.16					
15280	SHERWIN WILLIAMS #7308	0033-6	05/24/2017	\$57.75		06/27/2017		Limited-PO	PM 200 0 FL EXTRA 9 MARATHON
	1 442356317	PUBLIC SAFETY - POLICE		\$57.75					1/2 CVR FRAME 9" HD PRO
	LJ 1674 911			\$57.75					
	001	6509-46635 Gallon B30W12651 Pm		2.000	Invoiced	\$42.46			
	002	6504-90394 144602093 9 Inch 9		1.000	Invoiced	\$5.09			
	003	171-5135 105160900 9 Inch Fram		2.000	Invoiced	\$10.20			
69925	THE MISSISSIPPI LINK NEWSPAPERS 17006	PUBLIC WORKS	05/18/2017	\$57.15		06/27/2017		R&R-Invoice	SECTION 901 PAVEMENT REHAB AND
	1 450106444	PUBLIC WORKS		\$57.15					SIDEWALK IMPROVEMENTS TERRY RD
B1986	PURSER KRISTEN N ,	017052400	05/24/2017	\$57.75		06/27/2017		R&R-Invoice	WATER REFUND ACC 58794943
	30 2108	Liabilities		\$57.75					
20377	ENERGY	16547283\	06/27/2017	\$56.83		06/27/2017	16548422	UTILITY-PAYM	
	1 441706451	FIRE DEPARTMENT		\$56.83					
	0+16547283	FIRE DEPARTMENT		\$56.83					
61831	NAPA AUTO PARTS	JAC00037019526	05/22/2017	\$55.17		06/19/2017	0.1	\$56.83	ELECTRIC LIGHT AND POWER
	1 442406316	PUBLIC SAFETY - POLICE		\$55.17				R&R-Invoice	MUNICIPAL GARAGE
61831	NAPA AUTO PARTS	JAC00037019637	06/02/2017	\$56.00		06/02/2017		R&R-Invoice	MUNICIPAL GARAGE
	31 521356316	PUBLIC WORKS		\$56.00					
20377	ENERGY	19833508\	06/27/2017	\$54.20		06/27/2017	19833714	UTILITY-PAYM	
	5 504606451	PARKS & RECREATION		\$54.20					
	0+19833508	PARKS & RECREATION		\$54.20					
46828	NEXAIR LLC	05153860	05/31/2017	\$54.60		06/19/2017	0.1	\$54.20	ELECTRIC LIGHT AND POWER
	31 521356514	PUBLIC WORKS		\$54.60				R&R-Invoice	CYLINDER RENTAL
61831	NAPA AUTO PARTS	JAC00037019550	05/24/2017	\$54.14		05/24/2017		R&R-Invoice	MUNICIPAL GARAGE
	1 442406316	PUBLIC SAFETY - POLICE		\$54.14					
	1 442406316	PUBLIC SAFETY - POLICE		\$16.12					
	1 442406316	PUBLIC SAFETY - POLICE		\$1.08					
	1 442406316	PUBLIC SAFETY - POLICE		\$6.69					
	1 442406316	PUBLIC SAFETY - POLICE		\$30.25					
61831	NAPA AUTO PARTS	JAC00037019566	05/25/2017	\$54.72		05/25/2017		R&R-Invoice	MUNICIPAL GARAGE
	1 442406316	PUBLIC SAFETY - POLICE		\$54.72					
	1 442406316	PUBLIC SAFETY - POLICE		\$52.42					
	1 442406316	PUBLIC SAFETY - POLICE		\$2.30					
50375	REVELL HARDWARE CO INC	212284/1	05/31/2017	\$53.88		06/27/2017		Limited-PO	BLEACH LIQ REG 409 KITCHEN

AP755
 VENDOR PAYMENTS / FOR CLAIM DOCKET - 06/27/2017
 Report Title - AMOUNTS (DESCENDING) ALL TYPES
 Invoice Payments Under \$500

VEN#	VENDOR-NAME	INVOICE	INV-DATE	AMOUNT	AUTHORIZATION	DUE-DATE	REF-NUMBER	PAYMENT-TYPE	REMARKS
	LJ 1719 Shop	PUBLIC WORKS		\$53.88					CARWASH 2001
	001	Bleach Liq Reg Conc		6.000	Invoiced	\$17.94			
	002	409 Kitchen Lemon 22 Oz.		2.000	Invoiced	\$5.98			
	003	Protectant Blk Magic 23 Oz.		2.000	Invoiced	\$13.98			
	004	Carwash 2001 100 Oz.		2.000	Invoiced	\$15.98			
40789	CINTAS CORPORATION	210348875	06/06/2017	\$52.69		06/27/2017		R&R-Invoice	UNIFORM RENTAL
	5 504306516	PARKS & RECREATION		\$52.69					
61831	NAPA AUTO PARTS	JAC00037019521	05/22/2017	\$52.26		05/22/2017		R&R-Invoice	MUNICIPAL GARAGE
	1 451256316	PUBLIC WORKS		\$51.12					
	1 451256316	PUBLIC WORKS		\$1.14					
61831	NAPA AUTO PARTS	JAC00037019535	05/23/2017	\$52.85		05/23/2017		R&R-Invoice	MUNICIPAL GARAGE
	1 442406316	PUBLIC SAFETY - POLICE		\$52.85					
63932	DAVIS ARTHUR	060917	06/09/2017	\$52.50		06/27/2017		R&R-Invoice	OFFICIAL PAY
	5 501266419	PARKS & RECREATION		\$52.50					
68848	MCINTYRE WILLIAM	061217	06/12/2017	\$52.50		06/27/2017		R&R-Invoice	OFFICIAL PAY
	5 501266419	PARKS & RECREATION		\$52.50					
68848	MCINTYRE WILLIAM	061917	06/19/2017	\$52.50		06/27/2017		R&R-Invoice	OFFICIAL PAY
	5 501266419	PARKS & RECREATION		\$52.50					
70683	WILLIAMS TAMERA D	061917	06/19/2017	\$52.50		06/27/2017		R&R-Invoice	OFFICIAL PAY
	5 501266419	PARKS & RECREATION		\$52.50					
20225	ATMOS ENERGY	1276490158	06/27/2017	\$51.81		06/27/2017	3012724356	UTILITY-PAYM	
	5 501256453	PARKS & RECREATION		\$51.81					
	0+3012764901	PARKS & RECREATION		\$51.55		06/21/2017		0.1	\$51.81 GAS
	20377 ENTERGY	19825314\	06/27/2017	\$51.55		06/27/2017	19825728	UTILITY-PAYM	
	31 521306451	PUBLIC WORKS		\$51.55					
	0+19825314	PUBLIC WORKS		\$51.44		06/19/2017		0.1	\$51.55 ELECTRIC LIGHT AND POWER
59487	RIVER OAKS MANAGEMENT CO INC	1565569V4695	04/13/2017	\$51.44		06/27/2017		R&R-Invoice	GORDON JEREMY (17J-20-WC)00
	1 407926481	GENERAL GOVERNMENT		\$51.44					041317
61831	NAPA AUTO PARTS	JAC00037019522	05/22/2017	\$51.08		05/22/2017		R&R-Invoice	MUNICIPAL GARAGE
	1 451256316	PUBLIC WORKS		\$15.50					
	1 451256316	PUBLIC WORKS		\$34.44					
	1 451256316	PUBLIC WORKS		\$1.14					
61831	NAPA AUTO PARTS	JAC00037019560	05/24/2017	\$51.87		05/24/2017		R&R-Invoice	MUNICIPAL GARAGE
	31 521356316	PUBLIC WORKS		\$51.87					
61831	NAPA AUTO PARTS	JAC00037019650	06/02/2017	\$51.12		06/02/2017		R&R-Invoice	MUNICIPAL GARAGE
	1 451256316	PUBLIC WORKS		\$51.12					
61831	NAPA AUTO PARTS	JAC00037019675	06/05/2017	\$51.75		06/05/2017		R&R-Invoice	MUNICIPAL GARAGE
	1 441206316	FIRE DEPARTMENT		\$51.75					
61831	NAPA AUTO PARTS	JAC00037019678	06/05/2017	\$51.74		06/05/2017		R&R-Invoice	MUNICIPAL GARAGE
	1 441206316	FIRE DEPARTMENT		\$51.74					

AP755 VENDOR PAYMENTS / FOR CLAIM DOCKET - 06/27/2017
 Report Title - AMOUNTS (DESCENDING) ALL TYPES
 Invoice Payments Under \$500

VEN#	VENDOR-NAME	INVOICE	INV-DATE	AMOUNT	AUTHORIZATION	DUE-DATE	REF-NUMBER	PAYMENT-TYPE	REMARKS
06266	FEDEX	582606105	06/07/2017	\$49.83		06/27/2017		R&R-Invoice	SHIPPING
	1 423006422	GENERAL GOVERNMENT		\$49.83					
06371	PETTY CASH-FINANCE/TRAVEL	13424	06/12/2017	\$50.00		06/27/2017		R&R-Invoice	FILING FEE FOR PETITION FOR REHEARING
	1 407946419	GENERAL GOVERNMENT		\$50.00					
20225	ATMOS ENERGY	1279897458	06/27/2017	\$49.88		06/27/2017	3012724356	UTILITY-PAYM	
	1 441706453	FIRE DEPARTMENT		\$49.88					
	0+3012798974	FIRE DEPARTMENT				06/21/2017		\$49.88	GAS
60856	CITIBANK N A	8971175	05/15/2017	\$49.96		06/27/2017		Limited-Po	STEP LADDER
	1 453006315	PUBLIC WORKS		\$49.96					
	LJ 1595 PT-651			\$49.96					
	001			1.000	Invoiced	\$49.96			
B1980	WOODS-BUTT BRENDA	017052300	05/23/2017	\$48.42		06/27/2017		R&R-Invoice	WATER REFUND ACC 00794993
	30 2108	Liabilities		\$48.42					
20225	ATMOS ENERGY	1276361758	06/27/2017	\$47.99		06/27/2017	3012724356	UTILITY-PAYM	
	1 453006453	PUBLIC WORKS		\$47.99					
	0+3012763617	PUBLIC WORKS				06/21/2017		\$47.99	GAS
20225	ATMOS ENERGY	1279813458	06/27/2017	\$47.99		06/27/2017	3012724356	UTILITY-PAYM	
	5 501256453	PARKS & RECREATION		\$47.99					
	0+3012798134	PARKS & RECREATION				06/21/2017		\$47.99	GAS
20377	ENERGY	94198017\	06/27/2017	\$47.63		06/27/2017	954024	UTILITY-PAYM	
	5 504106451	PARKS & RECREATION		\$47.63					
	0+94198017	PARKS & RECREATION				06/19/2017		\$47.63	ELECTRIC LIGHT AND POWER
40789	CINTAS CORPORATION	210333657	05/02/2017	\$47.69		06/27/2017		R&R-Invoice	UNIFORM RENTAL
	31 522156516	PUBLIC WORKS		\$47.69					
40789	CINTAS CORPORATION	210339734	05/16/2017	\$47.69		06/27/2017		R&R-Invoice	UNIFORM RENTAL
	31 522156516	PUBLIC WORKS		\$47.69					
40789	CINTAS CORPORATION	210345857	05/30/2017	\$47.69		06/27/2017		R&R-Invoice	UNIFORM RENTAL
	31 522156516	PUBLIC WORKS		\$47.69					
61831	NAPA AUTO PARTS	JAC00037019488	05/19/2017	\$47.36		05/19/2017		R&R-Invoice	MUNICIPAL GARAGE
	1 451256316	PUBLIC WORKS		\$26.26					
	1 451256316	PUBLIC WORKS		\$21.10					
	09577 774635-01-8/060617		06/06/2017	\$47.71		06/27/2017		R&R-Invoice	INTERNET SERVICE FOR NORTHSIDE (WESTSIDE) SENIOR CENTER
71093	COMCAST	HUMAN & CULTURAL SERVICES		\$47.71					
	1 434206419	JAC00037019648	06/02/2017	\$46.02		06/02/2017		R&R-Invoice	MUNICIPAL GARAGE
61831	NAPA AUTO PARTS	PUBLIC WORKS		\$10.70					
	1 451256316	PUBLIC WORKS		\$35.32					
	1 451256316	PUBLIC WORKS		\$46.85		06/27/2017		R&R-Invoice	MONITORING SERVICE
63110	TYCO FIRE & SECURITY US MGMT	28562944	05/13/2017	\$46.85		06/27/2017		R&R-Invoice	WATER REFUND ACC 81544000
	5 501256419	PARKS & RECREATION		\$46.40					
B1962	LAMPTON JENNIFER G	017052200	05/22/2017	\$46.40		06/27/2017		R&R-Invoice	MUNICIPAL GARAGE
	30 2108	Liabilities		\$46.40					
61831	NAPA AUTO PARTS	JAC00037019481	05/19/2017	\$45.36		05/19/2017		R&R-Invoice	MUNICIPAL GARAGE
	31 522206316	PUBLIC WORKS		\$45.36					

AP755 VENDOR PAYMENTS / FOR CLAIM DOCKET - 06/27/2017
 Report Title - AMOUNTS (DESCENDING) ALL TYPES
 Invoice Payments Under \$500

VEN#	VENDOR-NAME	INVOICE	INV-DATE	AMOUNT	AUTHORIZATION	DUE-DATE	REF-NUMBER	PAYMENT-TYPE	REMARKS
63110	TYCO FIRE & SECURITY US MGMT	28562947	05/13/2017	\$45.25		06/27/2017		R&R-Invoice	MONITORING SERVICE
	5 501256419	PARKS & RECREATION		\$45.25					
10860	MEL LUNA SAW CO	84638	05/04/2017	\$44.85		06/27/2017		Regular-PO	6 PACK MIX STIHL
	1 448206299	PUBLIC WORKS		\$44.85					
	PJ 977 2 CYCLE OIL MIX								
	001	QUOTE--3.5 GAL MIX		3.000	Received	\$44.85			
53638	HALL'S TOWING SERVICE INC	403149	05/25/2017	\$45.00		06/27/2017		R&R-Invoice	WRECKER SERVICE
	1 442406465	PUBLIC SAFETY - POLICE		\$45.00					
61055	HICKS TOWING SERVICE	042117	04/21/2017	\$45.00		06/27/2017		R&R-Invoice	WRECKER SERVICE PCI1713
	1 442406465	PUBLIC SAFETY - POLICE		\$45.00					
61831	NAPA AUTO PARTS	JAC00037019506	05/22/2017	\$44.49		05/22/2017		R&R-Invoice	MUNICIPAL GARAGE
	31 522206316	PUBLIC WORKS		\$44.49					
65071	WASHINGTON-CHAMBERS RENE'E	060617	06/06/2017	\$45.00		06/27/2017		R&R-Invoice	POLL MANAGER ELECTION 06/06/17
	1 402206419	GENERAL GOVERNMENT		\$45.00					
65628	PALMER TERRI	062017	06/20/2017	\$45.00		06/27/2017		R&R-Invoice	OFFICIAL PAY
	5 501266419	PARKS & RECREATION		\$45.00					
69638	CENTRAL AUTO AND COLLISION INC	2716	10/01/2016	\$45.00		06/27/2017		R&R-Invoice	WRECKER SERVICE
	31 520206465	PUBLIC WORKS		\$45.00					
70455	AT & T MOBILITY	287262559423	04/20/2017	\$45.00		06/27/2017		R&R-Invoice	WIRELESS SERVICE ACCOUNT FAN 05129469 287262559423 FOUNDATION
	1 442206455	PUBLIC SAFETY - POLICE		\$45.00					
70654	WILLIAMS LULA G	060617	06/06/2017	\$45.00		06/27/2017		R&R-Invoice	POLL MANAGER ELECTION 06/06/17
	1 402206419	GENERAL GOVERNMENT		\$45.00					
B1978	VANDERVELDE JOHN	017052300	05/23/2017	\$44.09		06/27/2017		R&R-Invoice	WATER REFUND ACC 11323000
	30 2108	Liabilities		\$44.09					
20225	ATMOS ENERGY	1276425058	06/27/2017	\$43.24		06/27/2017	3012724356	UTILITY-PAYM	
	5 501256453	PARKS & RECREATION		\$43.24					
	0+3012764250	PARKS & RECREATION				06/21/2017			
20377	ENTERGY	39450929\	06/27/2017	\$43.45		06/27/2017	39967807	UTILITY-PAYM	
	31 522406451	PUBLIC WORKS		\$43.45					
	0+39450929	PUBLIC WORKS				06/19/2017			
20377	ENTERGY	85304517\	06/27/2017	\$43.28		06/27/2017	85381358	UTILITY-PAYM	
	1 454006451	PLANNING & DEVELOPMENT		\$43.28					
	0+85304517	PLANNING & DEVELOPMENT				06/19/2017			
61831	NAPA AUTO PARTS	JAC00037019615	06/01/2017	\$44.00		06/01/2017		R&R-Invoice	ELECTRIC LIGHT AND POWER MUNICIPAL GARAGE
	1 442406316	PUBLIC SAFETY - POLICE		\$14.24					
	1 442406316	PUBLIC SAFETY - POLICE		\$17.52					
	1 442406316	PUBLIC SAFETY - POLICE		\$6.64					
	1 442406316	PUBLIC SAFETY - POLICE		\$5.60					
20225	ATMOS ENERGY	1279709158	06/27/2017	\$41.34		06/27/2017	3012724356	UTILITY-PAYM	
	1 442206453	PUBLIC SAFETY - POLICE		\$41.34					
	0+3012797091	PUBLIC SAFETY - POLICE				06/21/2017			

AP755 VENDOR PAYMENTS / FOR CLAIM DOCKET - 06/27/2017
 Report Title - AMOUNTS (DESCENDING) ALL TYPES
 Invoice Payments Under \$500

VEN#	VENDOR-NAME	INVOICE	INV-DATE	AMOUNT	AUTHORIZATION	DUE-DATE	REF-NUMBER	PAYMENT-TYPE	REMARKS
20377	ENTERGY	1667636\\	06/27/2017	\$41.64		06/27/2017	1667834	UTILITY-PAYM	
	5 504106451	PARKS & RECREATION		\$41.64					
61831	NAPA AUTO PARTS	JAC00037019728	06/08/2017	\$41.91		06/19/2017	0.1	\$41.64	ELECTRIC LIGHT AND POWER
	0+16667636	PARKS & RECREATION		\$11.12		06/08/2017		R&R-Invoice	MUNICIPAL GARAGE
	31 521406316	PUBLIC WORKS		\$8.27					
	31 521406316	PUBLIC WORKS		\$22.52					
66021	COMCAST CABLE	0957770595-01-8	05/13/2017	\$41.02		06/27/2017		R&R-Invoice	09577-770595-01-8
	5 501106419	PARKS & RECREATION		\$41.02					CABLE SERVICES
B1990	COKER ANDREW S ,	017052400	05/24/2017	\$41.71		06/27/2017		R&R-Invoice	WATER REFUND ACC 20412869
	30 2108	Liabilities		\$41.71					
61831	NAPA AUTO PARTS	JAC00037019673	06/05/2017	\$40.52		06/05/2017		R&R-Invoice	MUNICIPAL GARAGE
	1 441206316	FIRE DEPARTMENT		\$22.64					
	1 441206316	FIRE DEPARTMENT		\$16.46					
	1 441206316	FIRE DEPARTMENT		\$1.42					
69925	THE MISSISSIPPI LINK NEWSPAPERS	17048	06/01/2017	\$40.59		06/27/2017		R&R-Invoice	NOTICE OF BIDDERS CITY OF
	1 414106444	ADMINISTRATION		\$40.59					OF TRAFFIC SIGN POST
									JACKSON TWELVE-MONTH SUPPLY
									5/25 6/1 451 WORDS
20225	ATMOS ENERGY	1276337758	06/27/2017	\$39.44		06/27/2017	3012724356	UTILITY-PAYM	
	1 442226453	PUBLIC SAFETY - POLICE		\$39.44					
	0+3012763377	PUBLIC SAFETY - POLICE		\$39.03		06/21/2017	0.1	\$39.44	GAS
20377	ENTERGY	\116434671	06/27/2017	\$39.03		06/27/2017		R&R-Invoice	
	1 454006451	PLANNING & DEVELOPMENT		\$39.19		06/27/2017		R&R-Invoice	
	1 448206451	PUBLIC WORKS		\$39.19					
20377	ENTERGY	\131410417	06/27/2017	\$39.32		06/27/2017		R&R-Invoice	
	1 448206451	PUBLIC WORKS		\$39.32					
40789	CINTAS CORPORATION	210345867	05/30/2017	\$39.98		06/27/2017		R&R-Invoice	UNIFORM RENTAL
	5 504536516	PARKS & RECREATION		\$39.98					
40789	CINTAS CORPORATION	210348878	06/06/2017	\$39.98		06/27/2017		R&R-Invoice	UNIFORM RENTAL
	5 504536516	PARKS & RECREATION		\$39.98					
60856	CITIBANK N A	7971261	05/16/2017	\$39.97		06/27/2017		Limited-PO	EXTENSION CORD
	1 453006461	PUBLIC WORKS		\$39.97					
	LJ 1618 Jpd Hq			\$39.97					
	001	14/3 100' Husky Extension Cord		1.000	Invoiced	\$39.97			
61831	NAPA AUTO PARTS	JAC00037019537	05/23/2017	\$39.86		05/23/2017		R&R-Invoice	MUNICIPAL GARAGE
	1 442406316	PUBLIC SAFETY - POLICE		\$39.86					
61831	NAPA AUTO PARTS	JAC00037019621	06/01/2017	\$39.72		06/01/2017		R&R-Invoice	MUNICIPAL GARAGE
	1 442406316	PUBLIC SAFETY - POLICE		\$39.72					
10014	LAKELAND RADIOLOGIST P A	5519060	03/01/2017	\$37.76		06/27/2017		R&R-Invoice	BELL DERRICK(15J-01-WC) 00
	1 407926481	GENERAL GOVERNMENT		\$37.76					03012017

AP755 VENDOR PAYMENTS / FOR CLAIM DOCKET - 06/27/2017
 Report Title - AMOUNTS (DESCENDING) ALL TYPES
 Invoice Payments Under \$500

VEN#	VENDOR-NAME	INVOICE	INV-DATE	AMOUNT	AUTHORIZATION	DUE-DATE	REF-NUMBER	PAYMENT-TYPE	REMARKS
20377	ENTERGY	\116434705	06/27/2017	\$37.87		06/27/2017		R&R-Invoice	
		PLANNING & DEVELOPMENT		\$37.87					
60856	CITIBANK N A	3971053	05/10/2017	\$37.45		06/27/2017		Limited-PO	FIRE ANT KILLER
		PUBLIC WORKS		\$37.45					
	LJ 1560 Shop			\$37.45					
	001	Spectracide Fire Ant Killer 3.		2.000	Invoiced	\$7.54			
	002	Milwaukee 12 PC Sawzall Blade		1.000	Invoiced	\$19.97			
	003	Gorilla Glue Quick Cure 2 Oz.		2.000	Invoiced	\$9.94			
72626	SMITH ROBERT	060117	06/01/2017	\$37.69		06/27/2017		R&R-Invoice	EMPLOYEE MILEAGE REIMBURSEMENT
		FIRE DEPARTMENT		\$37.69					
B1973	REESE RAVEN N A	017052300	05/23/2017	\$37.88		06/27/2017		R&R-Invoice	WATER REFUND ACC 01561032
		Liabilities		\$37.88					
20225	ATMOS ENERGY	1276142258	06/27/2017	\$36.59		06/27/2017	3012724356	UTILITY-PAYM	
		HUMAN & CULTURAL SERVICES		\$36.59					
	0+3012761422	HUMAN & CULTURAL SERVICES		\$36.76		06/21/2017		0.1	\$36.59 GAS
20377	ENTERGY	15681984\	06/27/2017	\$36.76		06/27/2017	15690217	UTILITY-PAYM	
		PLANNING & DEVELOPMENT		\$36.76					
	0+15681984	PLANNING & DEVELOPMENT		\$36.60		06/19/2017		0.1	\$36.76 ELECTRIC LIGHT AND POWER
40789	CINTAS CORPORATION	210348880	06/06/2017	\$36.60		06/27/2017		R&R-Invoice	UNIFORM RENTAL
		FIRE DEPARTMENT		\$36.60					
61831	NAPA AUTO PARTS	JAC00037019556	05/24/2017	\$36.88		05/24/2017		R&R-Invoice	MUNICIPAL GARAGE
		PUBLIC SAFETY - POLICE		\$5.92					
		PUBLIC SAFETY - POLICE		\$3.60					
		PUBLIC SAFETY - POLICE		\$27.36					
06371	PETTY CASH-FINANCE/TRAVEL	13442	06/12/2017	\$35.26		06/27/2017		R&R-Invoice	REIMBURSEMENT-M. BATTER-DAY CONFERENCE
		ADMINISTRATION		\$35.26					
61831	NAPA AUTO PARTS	JAC00037019576	05/25/2017	\$35.84		05/25/2017		R&R-Invoice	MUNICIPAL GARAGE
		PUBLIC SAFETY - POLICE		\$21.60					
		PUBLIC SAFETY - POLICE		\$14.24					
61831	NAPA AUTO PARTS	JAC00037019691	06/06/2017	\$34.42		06/06/2017		R&R-Invoice	MUNICIPAL GARAGE
		PUBLIC SAFETY - POLICE		\$16.66					
		PUBLIC SAFETY - POLICE		\$17.76					
63860	ROWLAND G GARRETT	2017-606	06/06/2017	\$35.00		06/27/2017		Limited-PO	PINE SOL
		PUBLIC WORKS		\$35.00					
	LJ 1716 Solid Waste			\$35.00					
	001	Pine Sol		1.000	Invoiced	\$35.00			
67698	C-SPIRE WIRELESS	0063072176/060417	06/04/2017	\$34.19		06/27/2017		R&R-Invoice	0063072176 MAY 5 17 JUNE 04
		PUBLIC SAFETY - POLICE		\$34.19					17
20377	ENTERGY	46477790\	06/27/2017	\$33.14		06/27/2017	46747770	UTILITY-PAYM	
		PLANNING & DEVELOPMENT		\$33.14					
	0+46477790	PLANNING & DEVELOPMENT		\$34.00		06/19/2017		0.1	\$33.14 ELECTRIC LIGHT AND POWER
20377	ENTERGY	85440386\	06/27/2017	\$34.00		06/27/2017	85440428	UTILITY-PAYM	

AP755 VENDOR PAYMENTS / FOR CLAIM DOCKET - 06/27/2017
 Report Title - AMOUNTS (DESCENDING) ALL TYPES
 Invoice Payments Under \$500

VEN#	VENDOR-NAME	INVOICE	INV-DATE	AMOUNT	AUTHORIZATION	DUE-DATE	REF-NUMBER	PAYMENT-TYPE	REMARKS
20225	ATMOS ENERGY	PUBLIC SAFETY - POLICE	06/27/2017	\$34.00		06/19/2017	0.1	\$34.00	ELECTRIC LIGHT AND POWER
	0+85440386	PUBLIC SAFETY - POLICE				06/27/2017	3012724356	UTILITY-PAYM	
	5 501406453	PARKS & RECREATION		\$32.77				\$32.77	GAS
	0+3012919128	PARKS & RECREATION				06/21/2017	0.1		
20377	ENTERGY	\116755885	06/27/2017	\$32.37		06/27/2017		R&R-Invoice	
	1 454006451	PLANNING & DEVELOPMENT				06/27/2017		R&R-Invoice	
40789	CINTAS CORPORATION	210348869	06/06/2017	\$32.68		06/27/2017		R&R-Invoice	UNIFORM RENTAL
	1 451246516	PUBLIC WORKS				05/19/2017		R&R-Invoice	MUNICIPAL GARAGE
61831	NAPA AUTO PARTS	JAC00037019489	05/19/2017	\$32.89		05/19/2017		R&R-Invoice	MUNICIPAL GARAGE
	1 451256316	PUBLIC WORKS				06/02/2017		R&R-Invoice	MUNICIPAL GARAGE
61831	NAPA AUTO PARTS	JAC00037019652	06/02/2017	\$31.31		06/27/2017		R&R-Invoice	
	31 521406316	PUBLIC WORKS		\$10.46					
	31 521406316	PUBLIC WORKS		\$10.14					
	31 521406316	PUBLIC WORKS		\$10.71					
68267	UNIVERSITY PHYSICIANS	163208630	02/05/2017	\$31.12		06/27/2017		R&R-Invoice	CROOM KENNIS WINSTON(173-15WC)
	1 407926481	GENERAL GOVERNMENT				06/27/2017		R&R-Invoice	00 020517
20377	ENTERGY	\105760185	06/27/2017	\$31.00		06/27/2017		R&R-Invoice	
	1 454006451	PLANNING & DEVELOPMENT				05/19/2017		R&R-Invoice	MUNICIPAL GARAGE
61831	NAPA AUTO PARTS	JAC00037019483	05/19/2017	\$30.92		05/19/2017		R&R-Invoice	MUNICIPAL GARAGE
	31 521406316	PUBLIC WORKS		\$4.46					
	31 521406316	PUBLIC WORKS		\$9.40					
	31 521406316	PUBLIC WORKS		\$21.06					
61831	NAPA AUTO PARTS	JAC00037019660	06/02/2017	\$30.24		06/02/2017		R&R-Invoice	MUNICIPAL GARAGE
	9 506106316	PUBLIC WORKS				06/27/2017		R&R-Invoice	WATER REFUND ACC
	30 2108	Libilities		\$30.24		06/27/2017		R&R-Invoice	28882000
20377	ENTERGY	\116507302	06/27/2017	\$29.03		06/27/2017		R&R-Invoice	
	1 448206451	PUBLIC WORKS				05/19/2017		R&R-Invoice	MUNICIPAL GARAGE
61831	NAPA AUTO PARTS	JAC00037019487	05/19/2017	\$29.48		05/19/2017		R&R-Invoice	MUNICIPAL GARAGE
	1 442406316	PUBLIC SAFETY - POLICE				06/27/2017		R&R-Invoice	VELISA WALKER
72153	COMPREHENSIVE WELLNESS PHARMAC	050117	05/01/2017	\$29.82		06/27/2017		R&R-Invoice	
	1 407926212	GENERAL GOVERNMENT				06/27/2017	550006520000101	UTILITY-PAYM	
20225	ATMOS ENERGY	4759979458	06/27/2017	\$28.22		06/27/2017		R&R-Invoice	
	1 442446453	PUBLIC SAFETY - POLICE				06/21/2017	0.1	\$28.22	GAS
40789	CINTAS CORPORATION	210345863	05/30/2017	\$27.60		06/27/2017		R&R-Invoice	UNIFORM RENTAL
	5 504516516	PARKS & RECREATION				06/27/2017		R&R-Invoice	UNIFORM RENTAL
40789	CINTAS CORPORATION	210348874	06/06/2017	\$27.60		06/27/2017		R&R-Invoice	UNIFORM RENTAL
	5 504516516	PARKS & RECREATION				06/27/2017		R&R-Invoice	UNIFORM RENTAL
40789	CINTAS CORPORATION	210348881	06/06/2017	\$27.87		06/27/2017		R&R-Invoice	UNIFORM RENTAL
	1 441606516	FIRE DEPARTMENT							

AP755 VENDOR PAYMENTS / FOR CLAIM DOCKET - 06/27/2017
 Report Title - AMOUNTS (DESCENDING) ALL TYPES
 Invoice Payments Under \$500

VEN#	VENDOR-NAME	INVOICE	INV-DATE	AMOUNT	AUTHORIZATION	DUE-DATE	REF-NUMBER	PAYMENT-TYPE	REMARKS
40789	CINTAS CORPORATION	210345845	05/30/2017	\$26.06		06/27/2017		R&R-Invoice	RUGS & AIR FRESHENER RENTAL
40789	CINTAS CORPORATION	PUBLIC WORKS		\$26.06				R&R-Invoice	RUGS AND AIR FRESHENER RENTAL
61831	NAPA AUTO PARTS	210348856	06/06/2017	\$26.06		06/27/2017		R&R-Invoice	MUNICIPAL GARAGE
61831	NAPA AUTO PARTS	PUBLIC WORKS		\$27.00				R&R-Invoice	MUNICIPAL GARAGE
61831	NAPA AUTO PARTS	JAC00037019484	05/19/2017	\$27.00		05/19/2017		R&R-Invoice	MUNICIPAL GARAGE
61831	NAPA AUTO PARTS	PUBLIC WORKS		\$26.61				R&R-Invoice	MUNICIPAL GARAGE
61831	NAPA AUTO PARTS	JAC00037019718	06/07/2017	\$26.61		06/07/2017		R&R-Invoice	MUNICIPAL GARAGE
61831	NAPA AUTO PARTS	PUBLIC WORKS		\$26.55				R&R-Invoice	ORDINANCE OF THE CITY COUNCIL
69925	THE MISSISSIPPI LINK NEWSPAPERS	17011	05/18/2017	\$26.55		06/27/2017		R&R-Invoice	MONUMENT STREET FROM MILL TO OF JACKSON HONORARILY NAMING CAPITAL TO DOROTHY MOORE DRIVE
69925	THE MISSISSIPPI LINK NEWSPAPERS	GENERAL GOVERNMENT		\$26.55				R&R-Invoice	WATER REFUND ACC 16493000
B1951	FUNCHES DELANO ,	017051900	05/19/2017	\$26.99		06/27/2017		R&R-Invoice	WATER REFUND ACC 21240114
B1951	FUNCHES DELANO ,	Liabilities		\$26.99				R&R-Invoice	WATER REFUND ACC 21240114
B1981	BAILEY ELTON P ,	017052300	05/23/2017	\$27.00		06/27/2017		R&R-Invoice	WATER REFUND ACC 16493000
B1981	BAILEY ELTON P ,	Liabilities		\$27.00				R&R-Invoice	WATER REFUND ACC 16493000
15280	SHERWIN WILLIAMS #7308	9939-5/05192017	05/19/2017	\$25.67		06/27/2017		Limited-PO	12" FRAME/4" BLK FOA CS BLACK FOAM 6" 2PK 6" CS FLOCKFOAM 2 PK PAINTTHINNER PLSTC
15280	SHERWIN WILLIAMS #7308	PUBLIC WORKS		\$25.67				Limited-PO	12" FRAME/4" BLK FOA CS BLACK FOAM 6" 2PK 6" CS FLOCKFOAM 2 PK PAINTTHINNER PLSTC
LJ	1648 Shop			\$25.67					
001		6501-82660 994012450 4 Inch 12		1.000	Invoiced	\$4.99			
002		6501-66309 996000850 7 Inch 6"		1.000	Invoiced	\$5.89			
003		6502-60193 996002450 6 Inch CS		1.000	Invoiced	\$5.39			
004		594-0333 Cr.Ptsw.P.41 Gallon P		1.000	Invoiced	\$9.40			
20377	ENERGY	16666802\\	06/27/2017	\$25.83		06/27/2017	16667081	UTILITY-PAYM	
20377	ENERGY	PARKS & RECREATION		\$25.83				UTILITY-PAYM	
0+16666802		5 504106451		\$25.83		06/19/2017	0.1	\$25.83	ELECTRIC LIGHT AND POWER
20377	ENERGY	56940968\\	06/27/2017	\$25.93		06/27/2017	58221086	UTILITY-PAYM	
20377	ENERGY	PARKS & RECREATION		\$25.93				UTILITY-PAYM	
0+56940968		5 504106451		\$25.87		06/19/2017	0.1	\$25.93	ELECTRIC LIGHT AND POWER
46163	KEHLING CO	S3170522001	03/30/2017	\$25.87		06/27/2017		Limited-PO	MALE BARB ELLS
46163	KEHLING CO	HUKAN & CULTURAL SERVICES		\$25.87				Limited-PO	MALE BARB ELLS
LJ	1235 Thalia Mara			\$25.87					
001		SBE075 3/4 Male 1/2 Barb Ell		4.000	Invoiced	\$1.23			
002		SBE050 1/2 Male 1/2 Barb Ell		6.000	Invoiced	\$1.68			
003		SBCPLG 1/2 Barb Swing Pipe Cou		6.000	Invoiced	\$2.45			
004		Hunter 100' Swing Pipe Flex-Sg		1.000	Invoiced	\$20.51			
61831	NAPA AUTO PARTS	JAC00037019582	05/25/2017	\$25.46		05/25/2017		R&R-Invoice	MUNICIPAL GARAGE
61831	NAPA AUTO PARTS	PUBLIC WORKS		\$24.18				R&R-Invoice	MUNICIPAL GARAGE
61831	NAPA AUTO PARTS	PUBLIC WORKS		\$1.28				R&R-Invoice	MUNICIPAL GARAGE
69925	THE MISSISSIPPI LINK NEWSPAPERS	17051	06/01/2017	\$25.95		06/27/2017		R&R-Invoice	ORDINANCE OF THE CITY COUNCIL

AP755
 VENDOR PAYMENTS / FOR CLAIM DOCKET - 06/27/2017
 Report Title - AMOUNTS (DESCENDING) ALL TYPES
 Invoice Payments Under \$500

VEN#	VENDOR-NAME	INVOICE	INV-DATE	AMOUNT	AUTHORIZATION	DUE-DATE	REF-NUMBER	PAYMENT-TYPE	REMARKS
15280	SHERWIN WILLIAMS	GENERAL GOVERNMENT	05/29/2017	\$25.95					PARK GOLF COURSE
	1 402006444								OF JACKSON RENAMING GROVE
		3041-7		\$24.13		06/27/2017		Limited-PO	ASE OIL GL BLACK
	1 442356317	PUBLIC SAFETY - POLICE		\$24.13					14"FRAME/6.5" PINK
	LJ 1680 911			\$24.13					
	001	6403-25676 Quart Allis200 Ase 0		1.000	Invoiced	\$19.83			
	002	6501-66721 996514150 14 In 14"		1.000	Invoiced	\$4.30			
20225	ATMOS ENERGY	PUBLIC WORKS	06/27/2017	\$24.23		06/27/2017	3012724356	UTILITY-PAYM	
	1 456106453			\$24.23					
	0+301276313	PUBLIC WORKS		\$24.23		06/21/2017		0.1	\$24.23 GAS
20225	ATMOS ENERGY	PARKS & RECREATION	06/27/2017	\$24.23		06/27/2017	3012724356	UTILITY-PAYM	
	5 501256453			\$24.23					
	0+3012764723	PARKS & RECREATION		\$24.23		06/21/2017		0.1	\$24.23 GAS
20225	ATMOS ENERGY	PUBLIC WORKS	06/27/2017	\$24.23		06/27/2017	3012724356	UTILITY-PAYM	
	1 453006453			\$24.23					
	0+4014521730	PUBLIC WORKS		\$24.69		06/21/2017		0.1	\$24.23 GAS
20377	ENTERGY	PARKS & RECREATION	06/27/2017	\$24.69		06/27/2017	195108	UTILITY-PAYM	
	5 504106451			\$24.69					
	0+19499318	PARKS & RECREATION		\$24.66		06/19/2017		0.1	\$24.69 ELECTRIC LIGHT AND POWER
40789	CINTAS CORPORATION	PUBLIC WORKS	06/08/2017	\$24.66		06/27/2017		R&R-Invoice	AIR FRESHENERS & MATS
	31 521356516			\$24.66					
61831	NAPA AUTO PARTS	JAC00037019503	05/19/2017	\$24.48		05/19/2017		R&R-Invoice	MUNICIPAL GARAGE
	9 506106316	PUBLIC WORKS		\$23.34					
	9 506106316	PUBLIC WORKS		\$1.14					
61831	NAPA AUTO PARTS	JAC00037019524	05/22/2017	\$24.48		05/22/2017		R&R-Invoice	MUNICIPAL GARAGE
	1 451256316	PUBLIC WORKS		\$23.34					
	1 451256316	PUBLIC WORKS		\$1.14					
61831	NAPA AUTO PARTS	JAC00037019612	06/01/2017	\$24.60		06/01/2017		R&R-Invoice	MUNICIPAL GARAGE
	1 442406316	PUBLIC SAFETY - POLICE		\$83.24					
	1 442406316	PUBLIC SAFETY - POLICE		\$58.64					
62652	SOUTHERN ASSOCIATION OF	PUBLIC SAFETY - POLICE	02/13/2017	\$25.00		06/27/2017		R&R-Invoice	PATRICIA BARNES DUES
	1 442256443			\$25.00					
40789	CINTAS CORPORATION	PUBLIC SAFETY - POLICE	06/13/2017	\$23.46		06/27/2017		R&R-Invoice	UNIFORM RENTAL
	1 450206516			\$23.46					
50375	REVELL HARDWARE CO INC	PUBLIC WORKS	05/31/2017	\$23.74		06/27/2017		Limited-PO	MASTER PADLOCK 4PK
	1 453006315			\$23.74					
	LJ 11727 CM 10 Stock/Ladder Locks			\$23.74					
	001	Master Padlock/4 PK KA		1.000	Invoiced	\$23.74			
61831	NAPA AUTO PARTS	JAC00037019528	05/22/2017	\$23.35		05/22/2017		R&R-Invoice	MUNICIPAL GARAGE
	1 453006316	PUBLIC WORKS		\$23.35					
61831	NAPA AUTO PARTS	JAC00037019529	05/22/2017	\$23.35		05/22/2017		R&R-Invoice	MUNICIPAL GARAGE
	31 521506316	PUBLIC WORKS		\$23.35					

AP755 VENDOR PAYMENTS / FOR CLAIM DOCKET - 06/27/2017
 Report Title - AMOUNTS (DESCENDING) ALL TYPES
 Invoice Payments Under \$500

VEN#	VENDOR-NAME	INVOICE	INV-DATE	AMOUNT	AUTHORIZATION	DUE-DATE	REF-NUMBER	PAYMENT-TYPE	REMARKS
61831	NAPA AUTO PARTS	JAC00037019651	06/02/2017	\$23.34		06/02/2017		R&R-Invoice	MUNICIPAL GARAGE
		1 451256316		\$23.34					
		PUBLIC WORKS							
B1993	GARRETT ROEININA R	06082017	06/08/2017	\$23.01		06/27/2017		R&R-Invoice	WATER/SEWER REFUND
		30 2325		\$23.01					
		Liabilities							
40789	CINTAS CORPORATION	210348864	06/06/2017	\$22.13		06/27/2017		R&R-Invoice	RUGS MATS & SOAP RENTAL
		31 521406516		\$22.13					
		PUBLIC WORKS							
61831	NAPA AUTO PARTS	JAC00037019687	06/05/2017	\$22.74		06/05/2017		R&R-Invoice	MUNICIPAL GARAGE
		1 441206316		\$22.74					
		FIRE DEPARTMENT							
61831	NAPA AUTO PARTS	JAC00037019689	06/05/2017	\$22.74		06/05/2017		R&R-Invoice	MUNICIPAL GARAGE
		1 451256316		\$22.74					
		PUBLIC WORKS							
63933	NORMAN RHONDA	060917	06/09/2017	\$22.50		06/27/2017		R&R-Invoice	OFFICIAL PAY
		5 501266419		\$22.50					
		PARKS & RECREATION							
68048	BELL TERESA A	062017	06/20/2017	\$22.50		06/27/2017		R&R-Invoice	OFFICIAL PAY
		5 501266419		\$22.50					
		PARKS & RECREATION							
70440	WEBB RUTHIE	060917	06/09/2017	\$22.50		06/27/2017		R&R-Invoice	OFFICIAL PAY
		5 501266419		\$22.50					
		PARKS & RECREATION							
68152	SECURITY & INTEGRATED SYSTEMS	130641	05/24/2017	\$21.95		06/27/2017		R&R-Invoice	MONITORING SERVICES
		5 504806420		\$21.95					
		PARKS & RECREATION							
68152	SECURITY & INTEGRATED SYSTEMS	130963	05/24/2017	\$21.95		06/27/2017		R&R-Invoice	PERIOD FOR 6-01-17 6-30-17
		5 501266419		\$21.95					
		PARKS & RECREATION							
20377	ENERGY	V115118317	06/27/2017	\$20.56		06/27/2017		R&R-Invoice	ALARM MONITORING SERVICES
		1 454006451		\$20.56					
		PLANNING & DEVELOPMENT							
61831	NAPA AUTO PARTS	JAC00037019630	06/01/2017	\$20.46		06/01/2017		R&R-Invoice	MUNICIPAL GARAGE
		1 442406316		\$19.32					
		PUBLIC SAFETY - POLICE							
06371	PETTY CASH-FINANCE/TRAVEL	13425	06/12/2017	\$1.14		06/27/2017		R&R-Invoice	SUPREME COURT FILING FEE
		1 407946419		\$20.00					
		GENERAL GOVERNMENT							
20377	ENERGY	19833904\\	06/27/2017	\$19.28		06/27/2017	19834340	R&R-Invoice	UTILITY-PAYM
		1 442206451		\$19.28					
		PUBLIC SAFETY - POLICE							
61831	NAPA AUTO PARTS	JAC00037019662	06/05/2017	\$20.00		06/19/2017	0.1	R&R-Invoice	ELECTRIC LIGHT AND POWER
		1 448306316		\$20.00					
		PUBLIC WORKS							
20377	ENERGY	V126131630	06/27/2017	\$18.07		06/27/2017		R&R-Invoice	MUNICIPAL GARAGE
		1 454006451		\$18.07					
		PLANNING & DEVELOPMENT							
61831	NAPA AUTO PARTS	JAC00037019499	05/19/2017	\$18.28		05/19/2017		R&R-Invoice	MUNICIPAL GARAGE
		1 441206316		\$18.28					
		FIRE DEPARTMENT							
61831	NAPA AUTO PARTS	JAC00037019531	05/22/2017	\$18.87		05/22/2017		R&R-Invoice	MUNICIPAL GARAGE
		1 441206316		\$18.87					
		FIRE DEPARTMENT							
61831	NAPA AUTO PARTS	JAC00037019656	06/02/2017	\$18.28		06/02/2017		R&R-Invoice	MUNICIPAL GARAGE
		9 506106316		\$18.28					
		PUBLIC WORKS							
61831	NAPA AUTO PARTS	JAC00037019713	06/07/2017	\$18.28		06/07/2017		R&R-Invoice	MUNICIPAL GARAGE
		1 451246316		\$18.28					
		PUBLIC WORKS							

AP755 VENDOR PAYMENTS / FOR CLAIM DOCKET - 06/27/2017
 Report Title - AMOUNTS (DESCENDING) ALL TYPES
 Invoice Payments Under \$500

VEN#	VENDOR-NAME	INVOICE	INV-DATE	AMOUNT	AUTHORIZATION	DUE-DATE	REF-NUMBER	PAYMENT-TYPE	REMARKS
61831	NAPA AUTO PARTS	JAC00037019726	06/08/2017	\$18.28		06/08/2017		R&R-Invoice	MUNICIPAL GARAGE
	1 451256316	PUBLIC WORKS		\$18.28					
69925	THE MISSISSIPPI LINK NEWSPAPERS	17010	05/18/2017	\$18.35		06/27/2017		R&R-Invoice	ORDINANCE OF THE CITY OF AS EMMETT TILL PARK 5/18
	1 402006444	GENERAL GOVERNMENT		\$18.35					JACKSON RENAMING ST PAUL PARK
B1960	NEAL CAROLYN V ,	017052200	05/22/2017	\$18.96		06/27/2017		R&R-Invoice	WATER REFUND ACC 63892769
	30 2108	Liabilities		\$18.96					
15280	SHERWIN WILLIAMS #7308	0112-8	05/30/2017	\$17.78		06/27/2017		Limited-PO	94 400 0 FL BLACK
	1 436006312	HUMAN & CULTURAL SERVICES		\$17.78					
	LJ 1714 Smith Rob. Museum			\$17.78					
	001			1.000	Invoiced				
20377	ENTERGY	6503-62841 Gallon B30B4600 Pm	06/27/2017	\$17.85		06/27/2017	1667339	UTILITY-PAYM	
	5 504106451	PARKS & RECREATION		\$17.85					
20377	ENTERGY	16669426\\	06/27/2017	\$17.85		06/19/2017		UTILITY-PAYM	
	0+16667081	PARKS & RECREATION		\$17.85					
20377	ENTERGY	16746620\\	06/27/2017	\$17.85		06/27/2017	167638	UTILITY-PAYM	
	5 504106451	PARKS & RECREATION		\$17.85					
20377	ENTERGY	19832963\\	06/27/2017	\$17.85		06/19/2017		UTILITY-PAYM	
	0+16746620	PARKS & RECREATION		\$17.85					
20377	ENTERGY	5 501806451	06/27/2017	\$17.85		06/27/2017	19833136	UTILITY-PAYM	
	0+19832963	PARKS & RECREATION		\$17.85					
20377	ENTERGY	\\131559775	06/27/2017	\$17.58		06/19/2017		R&R-Invoice	ELECTRIC LIGHT AND POWER
	31 522406451	PUBLIC WORKS		\$17.58					
61831	NAPA AUTO PARTS	JAC00037019476	05/19/2017	\$18.00		05/19/2017		R&R-Invoice	MUNICIPAL GARAGE
	1 451246316	PUBLIC WORKS		\$18.00					
66021	COMCAST CABLE	09577768864011 53117	05/31/2017	\$17.13		06/27/2017		R&R-Invoice	CABLE FOR DPW DIRECTOR'S OFFIC
	1 461106419	PUBLIC WORKS		\$17.13					
66021	COMCAST CABLE	09577768865019 053117	05/31/2017	\$17.13		06/27/2017		R&R-Invoice	CABLE FOR DPW DIRECTOR'S OFFIC
	1 461106419	PUBLIC WORKS		\$17.13					
69925	THE MISSISSIPPI LINK NEWSPAPERS	17050	06/01/2017	\$17.55		06/27/2017		R&R-Invoice	ORDINANCE OF THE CITY COUNCIL CAUSEY DRIVE TO PRAMUKH OF JACKSON HONORARILY NAMING SWAMI MAHARAJ 6/1
	1 402006444	GENERAL GOVERNMENT		\$17.55					
70173	SEXTON VIC	060617	06/06/2017	\$17.32		06/27/2017		R&R-Invoice	REIMBURSEMENT FOR RIBBON & CABLE TIES
	1 426106419	PLANNING & DEVELOPMENT		\$17.32					
B1952	MOORE SHONDA M. ,	017052200	05/22/2017	\$17.30		06/27/2017		R&R-Invoice	WATER REFUND ACC 78174000
	30 2108	Liabilities		\$17.30					
20377	ENTERGY	19833136\\	06/27/2017	\$16.10		06/27/2017	19833300	UTILITY-PAYM	
	5 504106451	PARKS & RECREATION		\$16.10					
	0+19833136	PARKS & RECREATION		\$16.10		06/19/2017		UTILITY-PAYM	ELECTRIC LIGHT AND POWER

VENDOR PAYMENTS / FOR CLAIM DOCKET - 06/27/2017
 Report Title - AMOUNTS (DESCENDING) ALL TYPES
 Invoice Payments Under \$500

VEN#	VENDOR-NAME	INVOICE	INV-DATE	AMOUNT	AUTHORIZATION	DUE-DATE	REF-NUMBER	PAYMENT-TYPE	REMARKS
40789	CINTAS CORPORATION	210345866	05/30/2017	\$16.59		06/27/2017		R&R-Invoice	UNIFORM RENTAL
40789	CINTAS CORPORATION	210348877	06/06/2017	\$16.59		06/27/2017		R&R-Invoice	UNIFORM RENTAL
40789	CINTAS CORPORATION	210348886	06/06/2017	\$16.32		06/27/2017		R&R-Invoice	UNIFORM RENTAL
61831	NAPA AUTO PARTS	JAC00037019688	06/05/2017	\$16.90		06/05/2017		R&R-Invoice	MUNICIPAL GARAGE
68267	UNIVERSITY PHYSICIANS	164678360	03/08/2017	\$16.51		06/27/2017		R&R-Invoice	SMITH MIRON B(17J-33-WC)00
20377	ENTERGY	73797680\	06/27/2017	\$15.16		06/27/2017	750223	UTILITY-PAYM	
40789	CINTAS CORPORATION	210348885	06/06/2017	\$15.14		06/19/2017	0.1	R&R-Invoice	ELECTRIC LIGHT AND POWER
68267	UNIVERSITY PHYSICIANS	165932560	04/11/2017	\$15.88		06/27/2017		R&R-Invoice	UNIFORM RENTAL
69925	THE MISSISSIPPI LINK NEWSPAPERS	17012	05/18/2017	\$15.40		06/27/2017		R&R-Invoice	ORDINANCE OF THE CITY COUNCIL WOODROW WILSON AVE FROM OF JACKSON HONORARILY NAMING MARTIN LUTHER KING DR TO LIVIN SHIPPING
06266	FEDEX	588008149	05/31/2017	\$15.00		06/27/2017		R&R-Invoice	
20377	ENTERGY	V116302431	06/27/2017	\$14.23		06/27/2017		R&R-Invoice	
40789	CINTAS CORPORATION	210345876	05/30/2017	\$14.68		06/27/2017		R&R-Invoice	UNIFORM RENTAL
40789	CINTAS CORPORATION	210348887	06/06/2017	\$14.68		06/27/2017		R&R-Invoice	UNIFORM RENTAL
40789	CINTAS CORPORATION	210351828	06/13/2017	\$14.68		06/27/2017		R&R-Invoice	UNIFORM RENTAL
61831	NAPA AUTO PARTS	JAC00037019657	06/02/2017	\$14.72		06/02/2017		R&R-Invoice	MUNICIPAL GARAGE
69927	CENTRAL MS MEDICAL EKG	130801151172	10/01/2016	\$14.16		06/27/2017		R&R-Invoice	WEST TOMMY(16U-133-WC)00
61959	COLLINS MICHAEL K	017052200	05/22/2017	\$15.00		06/27/2017		R&R-Invoice	102816 WATER REFUND ACC
61831	NAPA AUTO PARTS	JAC00037019496	05/19/2017	\$13.70		05/19/2017		R&R-Invoice	MUNICIPAL GARAGE
		PUBLIC WORKS		\$13.70					
		PUBLIC WORKS		\$6.15					

AP755 VENDOR PAYMENTS / FOR CLAIM DOCKET - 06/27/2017
 Report Title - AMOUNTS (DESCENDING) ALL TYPES
 Invoice Payments Under \$500

VEN#	VENDOR-NAME	INVOICE	INV-DATE	AMOUNT	AUTHORIZATION	DUE-DATE	REF-NUMBER	PAYMENT-TYPE	REMARKS
61831	NAPA AUTO PARTS	PUBLIC WORKS	05/19/2017	\$6.15-					
	1 453006316	JAC00037019504		\$13.55		05/19/2017		R&R-Invoice	MUNICIPAL GARAGE
	31 522206316	PUBLIC WORKS		\$1.14					
	31 522206316	PUBLIC WORKS		\$12.41					
61831	NAPA AUTO PARTS	JAC00037019573	05/25/2017	\$13.56		05/25/2017		R&R-Invoice	MUNICIPAL GARAGE
	1 442716316	PUBLIC SAFETY - POLICE		\$13.56					
61831	NAPA AUTO PARTS	JAC00037019602	05/30/2017	\$13.98		05/30/2017		R&R-Invoice	MUNICIPAL GARAGE
	31 521406316	PUBLIC WORKS		\$13.98					
61831	NAPA AUTO PARTS	JAC00037019685	06/05/2017	\$13.56		06/05/2017		R&R-Invoice	MUNICIPAL GARAGE
	1 442406316	PUBLIC SAFETY - POLICE		\$13.56					
61831	NAPA AUTO PARTS	JAC00037019714	06/07/2017	\$13.44		06/07/2017		R&R-Invoice	MUNICIPAL GARAGE
	31 521406316	PUBLIC WORKS		\$13.44					
B1969	KNOX SHAWN J ,	Liabilities	05/22/2017	\$13.85		06/27/2017		R&R-Invoice	WATER REFUND ACC 43853000
	30 2108	017052200		\$13.85					
B1971	GOSSE LANE M ,	Liabilities	05/22/2017	\$13.85		06/27/2017		R&R-Invoice	WATER REFUND ACC 01414000
	30 2108	017052200		\$13.85					
20377	ENTERGY	163652011	06/27/2017	\$12.05		06/27/2017	1641076	UTILITY-PAYM	
	174 944006451	PUBLIC WORKS		\$12.05					
20377	ENTERGY	1666353611	06/27/2017	\$12.99		06/19/2017		UTILITY-PAYM	
	1 448206451	PUBLIC WORKS		\$12.99					
20377	ENTERGY	1982508211	06/27/2017	\$12.05		06/27/2017	19825314	UTILITY-PAYM	
	174 944006451	PUBLIC WORKS		\$12.05					
20377	ENTERGY	1982572811	06/27/2017	\$12.05		06/19/2017		UTILITY-PAYM	
	0+19825082	PUBLIC WORKS		\$12.05					
20377	ENTERGY	116301771	06/27/2017	\$12.18		06/19/2017	0.1	\$12.05	ELECTRIC LIGHT AND POWER
	31 520106451	PUBLIC WORKS		\$12.18				R&R-Invoice	
50375	REVELL HARDWARE CO INC	211753/1	05/10/2017	\$12.72		06/27/2017		Limited-PO	HAMMER RIP JAW SAW
	1 453006317	PUBLIC WORKS		\$12.72					
	LJ 1559 Shop			\$12.72					
	001	Hammer Rip 16 Oz. Nyl Estwg		1.000	Invoiced	\$25.49			
	002	Jab Saw 6.5" L Pro Touch		1.000	Invoiced	\$13.49			
	003	Credits by Revell		1.000	Invoiced	\$26.26-			
61831	NAPA AUTO PARTS	JAC00037019474	05/19/2017	\$12.71		05/19/2017		R&R-Invoice	MUNICIPAL GARAGE
	1 442716316	PUBLIC SAFETY - POLICE		\$7.36					
61831	NAPA AUTO PARTS	JAC00037019505	05/19/2017	\$12.94		05/19/2017		R&R-Invoice	MUNICIPAL GARAGE
	1 442716316	PUBLIC SAFETY - POLICE		\$5.35					
61831	NAPA AUTO PARTS	JAC00037019729	06/08/2017	\$12.72		06/08/2017		R&R-Invoice	MUNICIPAL GARAGE
	1 451256316	PUBLIC WORKS		\$12.94					
	61831 NAPA AUTO PARTS			\$12.72					

AP755 VENDOR PAYMENTS / FOR CLAIM DOCKET - 06/27/2017
 Report Title - AMOUNTS (DESCENDING) ALL TYPES
 Invoice Payments Under \$500

VEN#	VENDOR-NAME	INVOICE	INV-DATE	AMOUNT	AUTHORIZATION	DUE-DATE	REF-NUMBER	PAYMENT-TYPE	REMARKS
B1979	AGENT GERALDINE , 30 2108	PUBLIC SAFETY - POLICE 017052300 Liabilities	05/23/2017	\$12.72		06/27/2017		R&R-Invoice	WATER REFUND ACC 30523000
B1987	GREGORY DEBORAH O , 30 2108	017052400 Liabilities	05/24/2017	\$12.74		06/27/2017		R&R-Invoice	WATER REFUND ACC 68861000
20377	ENTERGY 5 504106451	16668634\\ PARKS & RECREATION	06/27/2017	\$11.02		06/27/2017	16668865	UTILITY-PAYM	
20377	ENTERGY 0+16668634	18546085\\ PARKS & RECREATION	06/27/2017	\$11.96		06/27/2017	18546333	UTILITY-PAYM	
20377	ENTERGY 5 504606451	19819069\\ PARKS & RECREATION	06/27/2017	\$11.72		06/27/2017	198198	UTILITY-PAYM	
20377	ENTERGY 0+19819069	19825918\\ PUBLIC WORKS	06/27/2017	\$12.00		06/27/2017	198265	UTILITY-PAYM	
20377	ENTERGY 0+19825918	107755514 PUBLIC SAFETY - POLICE	06/27/2017	\$11.84		06/19/2017	0.1	\$11.72	ELECTRIC LIGHT AND POWER
20377	ENTERGY 1 453006451	125401976 PUBLIC WORKS	06/27/2017	\$11.84		06/27/2017		R&R-Invoice	
50375	REVELL HARDWARE CO INC 5 501806317	212191/1 PARKS & RECREATION	05/25/2017	\$11.69		06/27/2017		Limited-PO	HEX KEY L 9PC ING METRIC
61831	NAPA AUTO PARTS 31 522156316	JAC00037018303 PUBLIC WORKS	02/16/2017	\$11.70		02/16/2017		R&R-Invoice	MUNICIPAL GARAGE
61831	NAPA AUTO PARTS 1 442406316	JAC00037019608 PUBLIC SAFETY - POLICE	06/01/2017	\$11.64		06/01/2017		R&R-Invoice	MUNICIPAL GARAGE
61831	NAPA AUTO PARTS 1 442406316	JAC00037019736 PUBLIC SAFETY - POLICE	06/08/2017	\$11.40		06/08/2017		R&R-Invoice	MUNICIPAL GARAGE
06266	FEDDEX 1 442406422	579765014 PUBLIC SAFETY - POLICE	05/10/2017	\$10.10		06/27/2017		R&R-Invoice	SHIPPING
50375	REVELL HARDWARE CO INC 1 453006461	212481/1 PUBLIC WORKS	06/07/2017	\$10.78		06/27/2017		Limited-PO	CORNER DECO
61831	NAPA AUTO PARTS 31 522156316	JAC00037018194 PUBLIC WORKS	02/06/2017	\$10.74		02/06/2017		R&R-Invoice	MUNICIPAL GARAGE
61831	NAPA AUTO PARTS 31 522156316	JAC00037018533 PUBLIC WORKS	03/07/2017	\$10.64		03/07/2017		R&R-Invoice	MUNICIPAL GARAGE
	LJ 1776 Hood Bldg 001	Corner Deco 1/2" AB CD/4		2.000	Invoiced	\$10.78			

AP755
 VENDOR PAYMENTS / FOR CLAIM DOCKET - 06/27/2017
 Report Title - AMOUNTS (DESCENDING) ALL TYPES
 Invoice Payments Under \$500

VEN#	VENDOR-NAME	INVOICE	INV-DATE	AMOUNT	AUTHORIZATION	DUE-DATE	REF-NUMBER	PAYMENT-TYPE	REMARKS
61831	NAPA AUTO PARTS	PLANNING & DEVELOPMENT	06/07/2017	\$10.64		06/07/2017		R&R-Invoice	MUNICIPAL GARAGE
61831	NAPA AUTO PARTS	JAC00037019715	06/07/2017	\$10.70		06/07/2017		R&R-Invoice	MUNICIPAL GARAGE
68652	COMCAST CABLE	PUBLIC WORKS	05/31/2017	\$10.70		06/27/2017		R&R-Invoice	CABLE SERVICE JUNE 2017- DEPT
B1967	RICHMOND JAMES G ,	0957776887-01-8	05/31/2017	\$10.51		06/27/2017		R&R-Invoice	OF ADMINISTRATION
B1983	MEREDITH ALVIN C. SR. ,	ADMINISTRATION	05/22/2017	\$10.51		06/27/2017		R&R-Invoice	WATER REFUND ACC 61899279
06266	FEDEX	017052200	05/24/2017	\$10.97		06/27/2017		R&R-Invoice	WATER REFUND ACC 82439856
20377	ENTERGY	Liabilities	05/24/2017	\$10.02		06/27/2017		R&R-Invoice	WATER REFUND ACC 82439856
61831	NAPA AUTO PARTS	Liabilities	05/24/2017	\$10.02		06/27/2017		R&R-Invoice	WATER REFUND ACC 82439856
61831	NAPA AUTO PARTS	581274467	05/24/2017	\$9.11		06/27/2017		R&R-Invoice	SHIPPING
61831	NAPA AUTO PARTS	PLANNING & DEVELOPMENT	05/19/2017	\$9.14		05/19/2017		R&R-Invoice	MUNICIPAL GARAGE
61831	NAPA AUTO PARTS	JAC00037019502	05/19/2017	\$9.14		05/19/2017		R&R-Invoice	MUNICIPAL GARAGE
70226	MS STATE TAX COMMISSION	FIRE DEPARTMENT	06/05/2017	\$9.14		06/05/2017		R&R-Invoice	MUNICIPAL GARAGE
20377	ENTERGY	JAC00037019690	06/05/2017	\$9.14		06/05/2017		R&R-Invoice	MUNICIPAL GARAGE
20377	ENTERGY	PUBLIC WORKS	06/15/2017	\$10.00		06/27/2017		R&R-Invoice	GOVERNMENT TAGS TR 301
20377	ENTERGY	TR 301	06/15/2017	\$10.00		06/27/2017		R&R-Invoice	GOVERNMENT TAGS TR 301
20377	ENTERGY	PUBLIC SAFETY - POLICE	06/27/2017	\$8.03		06/27/2017		R&R-Invoice	UTILITY-PAYM
20377	ENTERGY	51568822\	06/27/2017	\$8.03		06/27/2017	52410180	R&R-Invoice	UTILITY-PAYM
20377	ENTERGY	PARKS & RECREATION	06/27/2017	\$8.03		06/27/2017		R&R-Invoice	UTILITY-PAYM
20377	ENTERGY	0+51568822	06/27/2017	\$8.86		06/19/2017	0.1	R&R-Invoice	ELECTRIC LIGHT AND POWER
20377	ENTERGY	110002425	06/27/2017	\$8.86		06/27/2017		R&R-Invoice	ELECTRIC LIGHT AND POWER
20377	ENTERGY	PUBLIC WORKS	06/27/2017	\$8.86		06/27/2017		R&R-Invoice	ELECTRIC LIGHT AND POWER
20377	ENTERGY	1448206451	06/27/2017	\$8.61		06/27/2017		R&R-Invoice	ELECTRIC LIGHT AND POWER
20377	ENTERGY	110041514	06/27/2017	\$8.61		06/27/2017		R&R-Invoice	ELECTRIC LIGHT AND POWER
20377	ENTERGY	PUBLIC WORKS	06/27/2017	\$8.38		06/27/2017		R&R-Invoice	ELECTRIC LIGHT AND POWER
20377	ENTERGY	110041522	06/27/2017	\$8.38		06/27/2017		R&R-Invoice	ELECTRIC LIGHT AND POWER
20377	ENTERGY	PUBLIC WORKS	06/27/2017	\$8.38		06/27/2017		R&R-Invoice	ELECTRIC LIGHT AND POWER
61831	NAPA AUTO PARTS	1116302191	06/27/2017	\$8.03		06/27/2017		R&R-Invoice	ELECTRIC LIGHT AND POWER
61831	NAPA AUTO PARTS	PUBLIC WORKS	05/19/2017	\$9.00		05/19/2017		R&R-Invoice	ELECTRIC LIGHT AND POWER
61831	NAPA AUTO PARTS	JAC00037019477	05/19/2017	\$9.00		05/19/2017		R&R-Invoice	ELECTRIC LIGHT AND POWER
61831	NAPA AUTO PARTS	PUBLIC WORKS	05/30/2017	\$8.26		05/30/2017		R&R-Invoice	ELECTRIC LIGHT AND POWER
61831	NAPA AUTO PARTS	JAC00037019601	05/30/2017	\$8.26		05/30/2017		R&R-Invoice	ELECTRIC LIGHT AND POWER
61831	NAPA AUTO PARTS	PUBLIC WORKS	06/05/2017	\$8.06		06/05/2017		R&R-Invoice	ELECTRIC LIGHT AND POWER
61831	NAPA AUTO PARTS	JAC00037019679	06/05/2017	\$8.06		06/05/2017		R&R-Invoice	ELECTRIC LIGHT AND POWER
61831	NAPA AUTO PARTS	PUBLIC SAFETY - POLICE	06/05/2017	\$8.06		06/05/2017		R&R-Invoice	ELECTRIC LIGHT AND POWER
61831	NAPA AUTO PARTS	JAC00037019682	06/05/2017	\$8.76		06/05/2017		R&R-Invoice	ELECTRIC LIGHT AND POWER
61831	NAPA AUTO PARTS	PUBLIC WORKS	06/05/2017	\$8.76		06/05/2017		R&R-Invoice	ELECTRIC LIGHT AND POWER
61831	NAPA AUTO PARTS	JAC00037019683	06/05/2017	\$8.06		06/05/2017		R&R-Invoice	ELECTRIC LIGHT AND POWER
61831	NAPA AUTO PARTS	PUBLIC SAFETY - POLICE	06/05/2017	\$8.06		06/05/2017		R&R-Invoice	ELECTRIC LIGHT AND POWER

AP755 VENDOR PAYMENTS / FOR CLAIM DOCKET - 06/27/2017
 Report Title - AMOUNTS (DESCENDING) ALL TYPES
 Invoice Payments Under \$500

VEN#	VENDOR-NAME	INVOICE	INV-DATE	AMOUNT	AUTHORIZATION	DUE-DATE	REF-NUMBER	PAYMENT-TYPE	REMARKS
69925	THE MISSISSIPPI LINK NEWSPAPERS	17013	05/18/2017	\$8.05		06/27/2017		R&R-Invoice	ORDINANCE OF THE CITY COUNCIL
	1 402006444	GENERAL GOVERNMENT		\$8.05					NEAR 1118 REV DR MARTIN LUTHER OF JACKSON NAMING THE BRIDGE KING JR DR TO REV P J WILLIAMS
20377	ENTERGY	15118664\	06/27/2017	\$7.68		06/27/2017	15135064	UTILITY-PAYM	
	31 521306451	PUBLIC WORKS		\$7.68					
20377	ENTERGY	15520398\	06/27/2017	\$7.58		06/27/2017	15520547	UTILITY-PAYM	
	1 441706451	FIRE DEPARTMENT		\$7.58					
20377	ENTERGY	16119380\	06/27/2017	\$7.58		06/19/2017	16148819	UTILITY-PAYM	
	1 441706451	FIRE DEPARTMENT		\$7.58					
20377	ENTERGY	16365363\	06/27/2017	\$7.58		06/27/2017	16365520	UTILITY-PAYM	
	174 944006451	PUBLIC WORKS		\$7.58					
20377	ENTERGY	16667834\	06/27/2017	\$7.58		06/19/2017	16668030	UTILITY-PAYM	
	5 504106451	PARKS & RECREATION		\$7.58					
20377	ENTERGY	18292896\	06/27/2017	\$7.58		06/27/2017	18293134	UTILITY-PAYM	
	5 501806451	PARKS & RECREATION		\$7.58					
20377	ENTERGY	18546333\	06/27/2017	\$7.58		06/19/2017	18546523	UTILITY-PAYM	
	5 504606451	PARKS & RECREATION		\$7.58					
20377	ENTERGY	18788968\	06/27/2017	\$7.58		06/19/2017	18789297	UTILITY-PAYM	
	1 454006451	PLANNING & DEVELOPMENT		\$7.58					
20377	ENTERGY	18984948\	06/27/2017	\$7.58		06/19/2017	19108414	UTILITY-PAYM	
	5 504106451	PARKS & RECREATION		\$7.58					
20377	ENTERGY	19868884\	06/27/2017	\$7.58		06/27/2017	204151	UTILITY-PAYM	
	5 504106451	PARKS & RECREATION		\$7.58					
20377	ENTERGY	22062301\	06/27/2017	\$7.58		06/19/2017	22108617	UTILITY-PAYM	
	9 506106451	PUBLIC WORKS		\$7.58					
20377	ENTERGY	1116301805	06/27/2017	\$7.58		06/19/2017	0.1	R&R-Invoice	ELECTRIC LIGHT AND POWER
	31 520106451	PUBLIC WORKS		\$7.58					
20377	ENTERGY	1116301896	06/27/2017	\$7.58		06/27/2017	0.1	R&R-Invoice	ELECTRIC LIGHT AND POWER
	31 520106451	PUBLIC WORKS		\$7.58					
20377	ENTERGY	1116302159	06/27/2017	\$7.58		06/27/2017	0.1	R&R-Invoice	ELECTRIC LIGHT AND POWER

AP755 VENDOR PAYMENTS / FOR CLAIM DOCKET - 06/27/2017
 Report Title - AMOUNTS (DESCENDING) ALL TYPES
 Invoice Payments Under \$500

VEN#	VENDOR-NAME	INVOICE	INV-DATE	AMOUNT	AUTHORIZATION	DUE-DATE	REF-NUMBER	PAYMENT-TYPE	REMARKS
20377	ENTERGY	31 520106451 PUBLIC WORKS	06/27/2017	\$7.58		06/27/2017		R&R-Invoice	
20377	ENTERGY	31 520106451 PUBLIC WORKS	06/27/2017	\$7.58		06/27/2017		R&R-Invoice	
40789	CINTAS CORPORATION	9 455106516 PUBLIC WORKS	05/30/2017	\$7.69		06/27/2017		R&R-Invoice	UNIFORM RENTAL
40789	CINTAS CORPORATION	9 455106516 PUBLIC WORKS	06/06/2017	\$7.69		06/27/2017		R&R-Invoice	UNIFORM RENTAL
40789	CINTAS CORPORATION	9 455106516 PUBLIC WORKS	06/13/2017	\$7.69		06/27/2017		R&R-Invoice	UNIFORM RENTAL
61831	NAPA AUTO PARTS	9 506106316 PUBLIC WORKS	05/25/2017	\$7.19		05/25/2017		R&R-Invoice	MUNICIPAL GARAGE
B1961	BROADWAY MAVIS A,	30 2108 Liabilities	05/22/2017	\$7.70		06/27/2017		R&R-Invoice	WATER REFUND ACC 96304000
B1975	MILLER PATRICA M,	30 2108 Liabilities	05/23/2017	\$7.06		06/27/2017		R&R-Invoice	WATER REFUND ACC 30881000
61831	NAPA AUTO PARTS	1 457006316 PUBLIC WORKS	05/19/2017	\$6.93		05/19/2017		R&R-Invoice	MUNICIPAL GARAGE
06266	FEDEX	1 442406422 PUBLIC SAFETY - POLICE	05/03/2017	\$5.05		06/27/2017		R&R-Invoice	SHIPPING
B1988	VAN TOAN C,	30 2108 Liabilities	05/24/2017	\$5.01		06/27/2017		R&R-Invoice	WATER REFUND ACC 52761000
06266	FEDEX	1 442406422 PUBLIC SAFETY - POLICE	05/24/2017	\$5.00		06/27/2017		R&R-Invoice	SHIPPING
60856	CITIBANK N A	1 436006317 HUMAN & CULTURAL SERVICES	05/18/2017	\$4.90		06/27/2017		Limited-PO	MAG CATCH
LJ	1641 Smith Rob. Museum	001 DBL Roller Catch w/Strike Zinc		4.000	Invoiced	\$3.92			
70173	SEXTON VIC	002 DBL Roller Catch w/'C' Clip Nc	06/19/2017	\$4.79	Invoiced	\$.98			
72147	SEQUEL ELECTRICAL SUPPLY, LLC	5 501266315 PLANNING & DEVELOPMENT	05/25/2017	\$4.67		06/27/2017		Limited-PO	REIMBURSEMENT FOR CERTIFICATE FRAME LEV 8681 MOG TO MED LMPHLD
LJ	1703 Forest Hill Ballfield	001 Lev 8681 Mog To Med LmpHldr Ad		1.000	Invoiced	\$4.67			
72153	COMPREHENSIVE WELLNESS PHARMAC	1 407926212 GENERAL GOVERNMENT	05/02/2017	\$5.00		06/27/2017		R&R-Invoice	VELISA WALKER 05/02/17
B1953	STAMPS FRANZSHAY M,	30 2108 Liabilities	05/22/2017	\$4.13		06/27/2017		R&R-Invoice	WATER REFUND ACC 10169052
20377	ENERGY	1 454006451 PLANNING & DEVELOPMENT	06/27/2017	\$3.73		06/27/2017	977760	UTILITY-PAYM	

AP755 VENDOR PAYMENTS / FOR CLAIM DOCKET - 06/27/2017
 Report Title - AMOUNTS (DESCENDING) ALL TYPES
 Invoice Payments Under \$500

VEN#	VENDOR-NAME	INVOICE	INV-DATE	AMOUNT	AUTHORIZATION	DUE-DATE	REF-NUMBER	PAYMENT-TYPE	REMARKS
61831	NAPA AUTO PARTS	PLANNING & DEVELOPMENT	05/23/2017	\$3.58		06/19/2017	0.1	\$3.73	ELECTRIC LIGHT AND POWER
61831	NAPA AUTO PARTS	JAC00037019538	05/23/2017	\$3.58		05/23/2017		R&R-Invoice	MUNICIPAL GARAGE
61831	NAPA AUTO PARTS	PUBLIC WORKS	06/02/2017	\$3.25		06/02/2017		R&R-Invoice	MUNICIPAL GARAGE
61831	NAPA AUTO PARTS	JAC00037019645	06/02/2017	\$3.25		06/02/2017		R&R-Invoice	MUNICIPAL GARAGE
61831	NAPA AUTO PARTS	PUBLIC WORKS	06/02/2017	\$3.76		06/02/2017		R&R-Invoice	MUNICIPAL GARAGE
61831	NAPA AUTO PARTS	JAC00037019647	06/02/2017	\$3.76		06/02/2017		R&R-Invoice	MUNICIPAL GARAGE
61955	COLLINS MARGARET N ,	PUBLIC WORKS	05/22/2017	\$3.85		06/27/2017		R&R-Invoice	WATER REFUND ACC
61955	COLLINS MARGARET N ,	Liabilities	05/22/2017	\$3.85		06/27/2017		R&R-Invoice	WATER REFUND ACC
61957	GRENFLEY DAVID W ,	Liabilities	05/22/2017	\$4.00		06/27/2017		R&R-Invoice	WATER REFUND ACC
61831	NAPA AUTO PARTS	Liabilities	05/19/2017	\$4.00		05/19/2017		R&R-Invoice	MUNICIPAL GARAGE
61831	NAPA AUTO PARTS	JAC00037019472	05/19/2017	\$2.90		05/19/2017		R&R-Invoice	MUNICIPAL GARAGE
61831	NAPA AUTO PARTS	PUBLIC SAFETY - POLICE	06/01/2017	\$2.10		06/01/2017		R&R-Invoice	MUNICIPAL GARAGE
61831	NAPA AUTO PARTS	JAC00037019610	06/01/2017	\$2.10		06/01/2017		R&R-Invoice	MUNICIPAL GARAGE
61831	NAPA AUTO PARTS	PUBLIC WORKS	06/05/2017	\$2.34		06/05/2017		R&R-Invoice	MUNICIPAL GARAGE
61831	NAPA AUTO PARTS	JAC00037019668	06/05/2017	\$2.34		06/05/2017		R&R-Invoice	MUNICIPAL GARAGE
61831	NAPA AUTO PARTS	PUBLIC SAFETY - POLICE	06/08/2017	\$2.35		06/08/2017		R&R-Invoice	MUNICIPAL GARAGE
61831	NAPA AUTO PARTS	JAC00037019738	06/08/2017	\$2.35		06/08/2017		R&R-Invoice	MUNICIPAL GARAGE
20377	ENERGY	PUBLIC SAFETY - POLICE	06/27/2017	\$1.72		06/27/2017	85440386	R&R-Invoice	MUNICIPAL GARAGE
20377	ENERGY	85440345\\	06/27/2017	\$1.72		06/27/2017	85440386	R&R-Invoice	MUNICIPAL GARAGE
61831	NAPA AUTO PARTS	PUBLIC SAFETY - POLICE	06/02/2017	\$2.59		06/02/2017		R&R-Invoice	MUNICIPAL GARAGE
61831	NAPA AUTO PARTS	JAC00037019638	06/02/2017	\$2.59		06/02/2017		R&R-Invoice	MUNICIPAL GARAGE
61831	NAPA AUTO PARTS	PUBLIC WORKS	06/05/2017	\$2.59		06/05/2017		R&R-Invoice	MUNICIPAL GARAGE
61831	NAPA AUTO PARTS	JAC00037019661	06/05/2017	\$2.59		06/05/2017		R&R-Invoice	MUNICIPAL GARAGE
61831	NAPA AUTO PARTS	PUBLIC SAFETY - POLICE	06/08/2017	\$2.34		06/08/2017		R&R-Invoice	MUNICIPAL GARAGE
61831	NAPA AUTO PARTS	JAC00037019738	06/08/2017	\$2.35		06/08/2017		R&R-Invoice	MUNICIPAL GARAGE
20377	ENERGY	PUBLIC SAFETY - POLICE	06/27/2017	\$1.72		06/27/2017	85440386	R&R-Invoice	MUNICIPAL GARAGE
20377	ENERGY	85440345\\	06/27/2017	\$1.72		06/27/2017	85440386	R&R-Invoice	MUNICIPAL GARAGE
32031	RICOH USA INC	PUBLIC SAFETY - POLICE	06/06/2017	\$1.69		06/19/2017	0.1	\$1.72	ELECTRIC LIGHT AND POWER
32031	RICOH USA INC	98914939	06/06/2017	\$1.69		06/19/2017	0.1	\$1.72	ELECTRIC LIGHT AND POWER
B1984	SPANN REBECCA R ,	PUBLIC WORKS	05/24/2017	\$1.91		06/27/2017		R&R-Invoice	COPIER RENTAL
B1984	SPANN REBECCA R ,	017052400	05/24/2017	\$1.91		06/27/2017		R&R-Invoice	COPIER RENTAL
61831	NAPA AUTO PARTS	Liabilities	06/06/2017	\$1.91		06/06/2017		R&R-Invoice	WATER REFUND ACC
61831	NAPA AUTO PARTS	JAC00037019699	06/06/2017	\$1.91		06/06/2017		R&R-Invoice	WATER REFUND ACC
61831	NAPA AUTO PARTS	ADMINISTRATION	06/05/2017	\$2.57		06/05/2017		R&R-Invoice	MUNICIPAL GARAGE
61831	NAPA AUTO PARTS	JAC00037019661	06/05/2017	\$2.57		06/05/2017		R&R-Invoice	MUNICIPAL GARAGE
61831	NAPA AUTO PARTS	PUBLIC WORKS	05/24/2017	\$1.86		05/24/2017		R&R-Invoice	MUNICIPAL GARAGE
61831	NAPA AUTO PARTS	JAC00037019549	05/24/2017	\$1.86		05/24/2017		R&R-Invoice	MUNICIPAL GARAGE
61831	NAPA AUTO PARTS	PUBLIC WORKS	05/24/2017	\$4.43		05/24/2017		R&R-Invoice	MUNICIPAL GARAGE
61831	NAPA AUTO PARTS	JAC00037019549	05/24/2017	\$4.43		05/24/2017		R&R-Invoice	MUNICIPAL GARAGE
61831	NAPA AUTO PARTS	PUBLIC WORKS	05/24/2017	\$105.16		05/24/2017		R&R-Invoice	MUNICIPAL GARAGE
61831	NAPA AUTO PARTS	JAC00037019549	05/24/2017	\$105.16		05/24/2017		R&R-Invoice	MUNICIPAL GARAGE
61831	NAPA AUTO PARTS	PUBLIC WORKS	05/24/2017	\$105.16		05/24/2017		R&R-Invoice	MUNICIPAL GARAGE
61831	NAPA AUTO PARTS	JAC00037019549	05/24/2017	\$105.16		05/24/2017		R&R-Invoice	MUNICIPAL GARAGE

*** Payments Under \$500 Total ***

=====

\$88,588.00

***** Grand-Total for Claims *****

=====

\$3,478,561.86

AP755 VENDOR PAYMENTS / FOR CLAIM DOCKET - 06/27/2017
 Report Title - AMOUNTS (DESCENDING) ALL TYPES

ACCOUNT NUMBER	DEPARTMENT DESCRIPTION	AMOUNT	ACCOUNT DESCRIPTION
1 1502	Assets	\$109,160.08	MAINTENANCE SUPPLY INVENTORY
1 2352	Liabilities	\$1,660.53	COLLECTION AGENCY FEE (25%) MC
1 2381	Liabilities	\$19,127.00	DUE TO LIBRARY
1 2390	Liabilities	\$126,318.82	DUE TO FUELMAN
1 401926473	GENERAL GOVERNMENT	\$3,109.52	TRAVEL EXPENSE - OUT OF CITY
1 402006444	GENERAL GOVERNMENT	\$279.80	LEGAL ADS, ADVERTISING, ETC.
1 402206419	GENERAL GOVERNMENT	\$71,916.75	OTHER PROFESSIONAL SERVICES
1 404106514	PLANNING & DEVELOPMENT	\$634.52	RENTAL OF EQUIPMENT
1 405006514	ADMINISTRATION	\$77.00	RENTAL OF EQUIPMENT
1 406106219	ADMINISTRATION	\$67.95	PRINTING SUPPLIES
1 406106316	ADMINISTRATION	\$207.43	MOTOR VEHICLE REPAIR MATERIALS
1 407006318	GENERAL GOVERNMENT	\$2,420.56	BOOKS & PERIODICALS(NOT LIBR)
1 407006421	GENERAL GOVERNMENT	\$147.84	POSTAGE, P O BOX RENT, ETC.
1 407006464	GENERAL GOVERNMENT	\$135.00	MACHINE/EQUIP MAINTENANCE
1 407706414	GENERAL GOVERNMENT	\$15,000.00	SPECIAL LEGAL SERVICES
1 407806419	GENERAL GOVERNMENT	\$5,600.00	OTHER PROFESSIONAL SERVICES
1 407856316	GENERAL GOVERNMENT	\$77.64	MOTOR VEHICLE REPAIR MATERIALS
1 407906514	GENERAL GOVERNMENT	\$376.97	RENTAL OF EQUIPMENT
1 407926212	GENERAL GOVERNMENT	\$4,119.52	CHEM, DRUGS, MED & LAB SUPPLIES
1 407926481	GENERAL GOVERNMENT	\$27,559.64	MEDICAL, DRUG TEST, HOSPITAL
1 407926766	GENERAL GOVERNMENT	\$17,472.97	WORKER'S COMP PAYMENT EMPLOYEE
1 407946419	GENERAL GOVERNMENT	\$1,746.00	OTHER PROFESSIONAL SERVICES
1 408106315	HUMAN & CULTURAL SERVICES	\$4,800.00	ELECTRICAL MATERIALS
1 408106464	HUMAN & CULTURAL SERVICES	\$285.00	MACHINE/EQUIP MAINTENANCE
1 411106514	ADMINISTRATION	\$383.63	RENTAL OF EQUIPMENT
1 411306419	ADMINISTRATION	\$951.51	OTHER PROFESSIONAL SERVICES
1 411406454	ADMINISTRATION	\$10.51	TELEPHONE
1 411406473	ADMINISTRATION	\$851.58	TRAVEL EXPENSE - OUT OF CITY
1 412106512	ADMINISTRATION	\$6,993.00	BUILDING RENTAL
1 413006122	PERSONNEL	\$600.00	BOARD & COMMITTEE MEMBERS
1 413006481	PERSONNEL	\$1,624.00	MEDICAL, DRUG TEST, HOSPITAL
1 413006512	PERSONNEL	\$4,225.58	BUILDING RENTAL
1 414106444	ADMINISTRATION	\$40.59	LEGAL ADS, ADVERTISING, ETC.
1 414106514	ADMINISTRATION	\$2,526.36	RENTAL OF EQUIPMENT
1 415106420	ADMINISTRATION	\$3,339.91	CONTRACT SECURITY SERVICES
1 415106489	ADMINISTRATION	\$765.48	CONTRACT LABOR
1 419106314	HUMAN & CULTURAL SERVICES	\$25.87	PLUMBING FIXTURES & SUPPLIES
1 419106317	HUMAN & CULTURAL SERVICES	\$295.43	OTHER REPAIR & MAINT MATERIALS
1 419106464	HUMAN & CULTURAL SERVICES	\$1,300.00	MACHINE/EQUIP MAINTENANCE
1 423006419	GENERAL GOVERNMENT	\$2,590.00	OTHER PROFESSIONAL SERVICES
1 423006422	GENERAL GOVERNMENT	\$49.83	FREIGHT EXPRESS & TRUCKING CHG
1 423006464	GENERAL GOVERNMENT	\$72.00	MACHINE/EQUIP MAINTENANCE

AP755

VENDOR PAYMENTS / FOR CLAIM DOCKET - 06/27/2017
Report Title - AMOUNTS (DESCENDING) ALL TYPES

ACCOUNT NUMBER	DEPARTMENT DESCRIPTION	AMOUNT	ACCOUNT DESCRIPTION
1 426106419	PLANNING & DEVELOPMENT	\$22.11	OTHER PROFESSIONAL SERVICES
1 426106443	PLANNING & DEVELOPMENT	\$185.00	DUES, MEM. REGIS FEES, TUITION
1 426106473	PLANNING & DEVELOPMENT	\$129.03	TRAVEL EXPENSE - OUT OF CITY
1 431006419	PUBLIC WORKS	\$37,561.42	OTHER PROFESSIONAL SERVICES
1 433006316	HUMAN & CULTURAL SERVICES	\$133.78	MOTOR VEHICLE REPAIR MATERIALS
1 433006419	HUMAN & CULTURAL SERVICES	\$70.00	OTHER PROFESSIONAL SERVICES
1 433006451	HUMAN & CULTURAL SERVICES	\$903.88	ELECTRIC LIGHT AND POWER
1 433006512	HUMAN & CULTURAL SERVICES	\$8,909.12	BUILDING RENTAL
1 433006742	HUMAN & CULTURAL SERVICES	\$35,000.00	CONTRIBUTION TO OTHER AGENCIES
1 434206419	HUMAN & CULTURAL SERVICES	\$1,110.51	OTHER PROFESSIONAL SERVICES
1 436006312	HUMAN & CULTURAL SERVICES	\$77.66	PAINTS, OILS, & GLASS
1 436006317	HUMAN & CULTURAL SERVICES	\$4,680.00	OTHER REPAIR & MAINT MATERIALS
1 436006419	HUMAN & CULTURAL SERVICES	\$1,264.29	OTHER PROFESSIONAL SERVICES
1 436206299	HUMAN & CULTURAL SERVICES	\$5,490.66	OTHER OPERATING SUPPLIES
1 436206313	HUMAN & CULTURAL SERVICES	\$2,000.00	STRUCTURAL STEEL & RELATED MAT
1 436206419	HUMAN & CULTURAL SERVICES	\$2,000.00	OTHER PROFESSIONAL SERVICES
1 441106514	FIRE DEPARTMENT	\$410.70	RENTAL OF EQUIPMENT
1 441206215	FIRE DEPARTMENT	\$37.69	FUEL USAGE
1 441206299	FIRE DEPARTMENT	\$238.60	OTHER OPERATING SUPPLIES
1 441206316	FIRE DEPARTMENT	\$1,734.62	MOTOR VEHICLE REPAIR MATERIALS
1 441606299	FIRE DEPARTMENT	\$276.29	OTHER OPERATING SUPPLIES
1 441606316	FIRE DEPARTMENT	\$146.45	MOTOR VEHICLE REPAIR MATERIALS
1 441606516	FIRE DEPARTMENT	\$64.47	UNIFORMS, RUGS ETC. RENTAL
1 441706316	FIRE DEPARTMENT	\$9.94	MOTOR VEHICLE REPAIR MATERIALS
1 441706451	FIRE DEPARTMENT	\$5,301.52	ELECTRIC LIGHT AND POWER
1 441706453	FIRE DEPARTMENT	\$817.74	GAS
1 441706461	FIRE DEPARTMENT	\$1,065.00	BUILDINGS MAINTENANCE
1 441706464	FIRE DEPARTMENT	\$843.48	MACHINE/EQUIP MAINTENANCE
1 442106419	PUBLIC SAFETY - POLICE	\$882.59	OTHER PROFESSIONAL SERVICES
1 442206451	PUBLIC SAFETY - POLICE	\$408.37	ELECTRIC LIGHT AND POWER
1 442206453	PUBLIC SAFETY - POLICE	\$278.44	GAS
1 442206454	PUBLIC SAFETY - POLICE	\$612.00	TELEPHONE
1 442206455	PUBLIC SAFETY - POLICE	\$1,788.69	CELLULAR PHONES
1 442206465	PUBLIC SAFETY - POLICE	\$7,705.00	AUTO + TRUCK GARAGE + OTHER
1 442216451	PUBLIC SAFETY - POLICE	\$311.13	ELECTRIC LIGHT AND POWER
1 442226453	PUBLIC SAFETY - POLICE	\$39.44	GAS
1 442236516	PUBLIC SAFETY - POLICE	\$551.64	UNIFORMS, RUGS ETC. RENTAL
1 442246464	PUBLIC SAFETY - POLICE	\$204.00	MACHINE/EQUIP MAINTENANCE
1 442256419	PUBLIC SAFETY - POLICE	\$1,260.00	OTHER PROFESSIONAL SERVICES
1 442256443	PUBLIC SAFETY - POLICE	\$25.00	DUES, MEM. REGIS FEES, TUITION
1 442256464	PUBLIC SAFETY - POLICE	\$958.00	MACHINE/EQUIP MAINTENANCE
1 442356317	PUBLIC SAFETY - POLICE	\$81.88	OTHER REPAIR & MAINT MATERIALS

AP755
 VENDOR PAYMENTS / FOR CLAIM DOCKET - 06/27/2017
 Report Title - AMOUNTS (DESCENDING) ALL TYPES

ACCOUNT NUMBER	DEPARTMENT DESCRIPTION	AMOUNT	ACCOUNT DESCRIPTION
1 442356464	PUBLIC SAFETY - POLICE	\$130.00	MACHINE/EQUIP MAINTENANCE
1 442406316	PUBLIC SAFETY - POLICE	\$24,456.57	MOTOR VEHICLE REPAIR MATERIALS
1 442406422	PUBLIC SAFETY - POLICE	\$35.15	FREIGHT EXPRESS & TRUCKING CHG
1 442406423	PUBLIC SAFETY - POLICE	\$175.75	AUTO LICENSE TITLES
1 442406465	PUBLIC SAFETY - POLICE	\$360.00	AUTO + TRUCK GARAGE + OTHER
1 442416451	PUBLIC SAFETY - POLICE	\$653.69	ELECTRIC LIGHT AND POWER
1 442426451	PUBLIC SAFETY - POLICE	\$85.85	ELECTRIC LIGHT AND POWER
1 442426512	PUBLIC SAFETY - POLICE	\$4,369.77	BUILDING RENTAL
1 442446451	PUBLIC SAFETY - POLICE	\$906.05	ELECTRIC LIGHT AND POWER
1 442446453	PUBLIC SAFETY - POLICE	\$28.22	GAS
1 442716218	PUBLIC SAFETY - POLICE	\$556.00	OFFICE SUPPLIES
1 442716316	PUBLIC SAFETY - POLICE	\$146.06	MOTOR VEHICLE REPAIR MATERIALS
1 442716444	PUBLIC SAFETY - POLICE	\$216.00	LEGAL ADS, ADVERTISING, ETC.
1 442716447	PUBLIC SAFETY - POLICE	\$10,777.00	CONTRACT-GRASS, WEEDS, BOARD UP
1 442716485	PUBLIC SAFETY - POLICE	\$4,095.00	CONTRACT CONSTRUCTION
1 443106299	ADMINISTRATION	\$171.74	OTHER OPERATING SUPPLIES
1 443106316	ADMINISTRATION	\$334.41	MOTOR VEHICLE REPAIR MATERIALS
1 443106451	ADMINISTRATION	\$1,646.68	ELECTRIC LIGHT AND POWER
1 443106453	ADMINISTRATION	\$93.61	GAS
1 443106514	ADMINISTRATION	\$242.65	RENTAL OF EQUIPMENT
1 444106514	PLANNING & DEVELOPMENT	\$238.05	RENTAL OF EQUIPMENT
1 444106516	PLANNING & DEVELOPMENT	\$149.66	UNIFORMS, RUGS ETC. RENTAL
1 444306316	PLANNING & DEVELOPMENT	\$167.42	MOTOR VEHICLE REPAIR MATERIALS
1 444606316	PLANNING & DEVELOPMENT	\$168.77	MOTOR VEHICLE REPAIR MATERIALS
1 448106218	PUBLIC WORKS	\$83.89	OFFICE SUPPLIES
1 448106514	PUBLIC WORKS	\$160.70	RENTAL OF EQUIPMENT
1 448106516	PUBLIC WORKS	\$386.74	UNIFORMS, RUGS ETC. RENTAL
1 448206299	PUBLIC WORKS	\$44.85	OTHER OPERATING SUPPLIES
1 448206315	PUBLIC WORKS	\$1,100.00	ELECTRICAL MATERIALS
1 448206316	PUBLIC WORKS	\$173.26	MOTOR VEHICLE REPAIR MATERIALS
1 448206451	PUBLIC WORKS	\$265.34	ELECTRIC LIGHT AND POWER
1 448306316	PUBLIC WORKS	\$20.00	MOTOR VEHICLE REPAIR MATERIALS
1 448806465	PUBLIC WORKS	\$200.00	AUTO + TRUCK GARAGE + OTHER
1 450106444	PUBLIC WORKS	\$57.15	LEGAL ADS, ADVERTISING, ETC.
1 450106514	PUBLIC WORKS	\$467.12	RENTAL OF EQUIPMENT
1 450206516	PUBLIC WORKS	\$38.60	UNIFORMS, RUGS ETC. RENTAL
1 451106218	PUBLIC WORKS	\$445.98	OFFICE SUPPLIES
1 451106316	PUBLIC WORKS	\$106.82	MOTOR VEHICLE REPAIR MATERIALS
1 451106514	PUBLIC WORKS	\$160.68	RENTAL OF EQUIPMENT
1 451246316	PUBLIC WORKS	\$1,134.79	MOTOR VEHICLE REPAIR MATERIALS
1 451246320	PUBLIC WORKS	\$12,133.47	ASPHALT-ROUTINE MAINTENANCE
1 451246465	PUBLIC WORKS	\$200.00	AUTO + TRUCK GARAGE + OTHER

AP755
 VENDOR PAYMENTS / FOR CLAIM DOCKET - 06/27/2017
 Report Title - AMOUNTS (DESCENDING) ALL TYPES

ACCOUNT NUMBER	DEPARTMENT DESCRIPTION	AMOUNT	ACCOUNT DESCRIPTION
1 451246514	PUBLIC WORKS	\$89.26	RENTAL OF EQUIPMENT
1 451246516	PUBLIC WORKS	\$126.37	UNIFORMS, RUGS ETC. RENTAL
1 451256316	PUBLIC WORKS	\$1,675.41	MOTOR VEHICLE REPAIR MATERIALS
1 451256465	PUBLIC WORKS	\$200.00	AUTO + TRUCK GARAGE + OTHER
1 451256514	PUBLIC WORKS	\$89.26	RENTAL OF EQUIPMENT
1 451256516	PUBLIC WORKS	\$573.99	UNIFORMS, RUGS ETC. RENTAL
1 453006315	PUBLIC WORKS	\$73.70	ELECTRICAL MATERIALS
1 453006316	PUBLIC WORKS	\$531.56	MOTOR VEHICLE REPAIR MATERIALS
1 453006317	PUBLIC WORKS	\$129.72	OTHER REPAIR & MAINT MATERIALS
1 453006451	PUBLIC WORKS	\$11,402.79	ELECTRIC LIGHT AND POWER
1 453006453	PUBLIC WORKS	\$134.49	GAS
1 453006461	PUBLIC WORKS	\$2,830.83	BUILDINGS MAINTENANCE
1 453006464	PUBLIC WORKS	\$980.00	MACHINE/EQUIP MAINTENANCE
1 453006516	PUBLIC WORKS	\$96.55	UNIFORMS, RUGS ETC. RENTAL
1 454006451	PLANNING & DEVELOPMENT	\$837.11	ELECTRIC LIGHT AND POWER
1 456106217	PUBLIC WORKS	\$428.47	UNIFORMS & WORK CLOTHING
1 456106240	PUBLIC WORKS	\$1.69	NON-CAPITALIZED EQUIPMENT
1 456106316	PUBLIC WORKS	\$199.20	MOTOR VEHICLE REPAIR MATERIALS
1 456106419	PUBLIC WORKS	\$70.00	OTHER PROFESSIONAL SERVICES
1 456106453	PUBLIC WORKS	\$24.23	GAS
1 457006213	PUBLIC WORKS	\$7,289.10	CLEANING & SANITATION SUPPLIES
1 457006316	PUBLIC WORKS	\$302.79	MOTOR VEHICLE REPAIR MATERIALS
1 457006516	PUBLIC WORKS	\$143.92	UNIFORMS, RUGS ETC. RENTAL
1 461106419	PUBLIC WORKS	\$34.26	OTHER PROFESSIONAL SERVICES
1 461106514	PUBLIC WORKS	\$470.31	RENTAL OF EQUIPMENT
1 461306516	PUBLIC WORKS	\$104.33	UNIFORMS, RUGS ETC. RENTAL
1 491006451	HUMAN & CULTURAL SERVICES	\$375.61	ELECTRIC LIGHT AND POWER
1 491006453	HUMAN & CULTURAL SERVICES	\$36.59	GAS
1 493006419	GENERAL GOVERNMENT	\$125.00	OTHER PROFESSIONAL SERVICES
2 907006217	PUBLIC SAFETY - POLICE	\$3,874.25	UNIFORMS & WORK CLOTHING
2 907006419	PUBLIC SAFETY - POLICE	\$16,343.32	OTHER PROFESSIONAL SERVICES
4 904006419	ADMINISTRATION	\$1,052.80	OTHER PROFESSIONAL SERVICES
4 904006443	ADMINISTRATION	\$3,533.88	DUES, MEM. REGIS FEES, TUITION
4 904006464	ADMINISTRATION	\$45,019.71	MACHINE/EQUIP MAINTENANCE
4 904006847	ADMINISTRATION	\$10,440.00	DATA PROCESSING EQUIPMENT
5 2323	Liabilities	\$200.00	OTHER REFUNDS
5 501106419	PARKS & RECREATION	\$6,041.02	OTHER PROFESSIONAL SERVICES
5 501106512	PARKS & RECREATION	\$3,151.49	BUILDING RENTAL
5 501256213	PARKS & RECREATION	\$193.50	CLEANING & SANITATION SUPPLIES
5 501256419	PARKS & RECREATION	\$3,164.10	OTHER PROFESSIONAL SERVICES
5 501256451	PARKS & RECREATION	\$581.73	ELECTRIC LIGHT AND POWER
5 501256453	PARKS & RECREATION	\$300.79	GAS

AP755

VENDOR PAYMENTS / FOR CLAIM DOCKET - 06/27/2017
Report Title - AMOUNTS (DESCENDING) ALL TYPES

ACCOUNT NUMBER	DEPARTMENT DESCRIPTION	AMOUNT	ACCOUNT DESCRIPTION
5 501266221	PARKS & RECREATION	\$316.98	RECREATIONAL SUPPLIES
5 501266311	PARKS & RECREATION	\$224.75	BUILDING MATERIALS
5 501266315	PARKS & RECREATION	\$4.67	ELECTRICAL MATERIALS
5 501266419	PARKS & RECREATION	\$5,309.45	OTHER PROFESSIONAL SERVICES
5 501406419	PARKS & RECREATION	\$15,000.00	OTHER PROFESSIONAL SERVICES
5 501406451	PARKS & RECREATION	\$191.21	ELECTRIC LIGHT AND POWER
5 501406453	PARKS & RECREATION	\$32.77	GAS
5 501806317	PARKS & RECREATION	\$11.69	OTHER REPAIR & MAINT MATERIALS
5 501806451	PARKS & RECREATION	\$234.48	ELECTRIC LIGHT AND POWER
5 504106316	PARKS & RECREATION	\$401.46	MOTOR VEHICLE REPAIR MATERIALS
5 504106419	PARKS & RECREATION	\$3,600.00	OTHER PROFESSIONAL SERVICES
5 504106420	PARKS & RECREATION	\$3,304.06	CONTRACT SECURITY SERVICES
5 504106451	PARKS & RECREATION	\$3,508.89	ELECTRIC LIGHT AND POWER
5 504106516	PARKS & RECREATION	\$551.22	UNIFORMS, RUGS ETC. RENTAL
5 504306299	PARKS & RECREATION	\$81.84	OTHER OPERATING SUPPLIES
5 504306316	PARKS & RECREATION	\$67.13	MOTOR VEHICLE REPAIR MATERIALS
5 504306514	PARKS & RECREATION	\$5,054.10	RENTAL OF EQUIPMENT
5 504306516	PARKS & RECREATION	\$52.69	UNIFORMS, RUGS ETC. RENTAL
5 504516516	PARKS & RECREATION	\$55.20	UNIFORMS, RUGS ETC. RENTAL
5 504526516	PARKS & RECREATION	\$299.87	UNIFORMS, RUGS ETC. RENTAL
5 504536316	PARKS & RECREATION	\$14.72	MOTOR VEHICLE REPAIR MATERIALS
5 504536516	PARKS & RECREATION	\$79.96	UNIFORMS, RUGS ETC. RENTAL
5 504606451	PARKS & RECREATION	\$3,132.80	ELECTRIC LIGHT AND POWER
5 504806420	PARKS & RECREATION	\$21.95	CONTRACT SECURITY SERVICES
5 504806516	PARKS & RECREATION	\$33.18	UNIFORMS, RUGS ETC. RENTAL
9 455106420	PUBLIC WORKS	\$795.60	CONTRACT SECURITY SERVICES
9 455106426	PUBLIC WORKS	\$161,732.75	TIPPING FEES
9 455106516	PUBLIC WORKS	\$23.07	UNIFORMS, RUGS ETC. RENTAL
9 506106213	PUBLIC WORKS	\$35.00	CLEANING & SANITATION SUPPLIES
9 506106316	PUBLIC WORKS	\$1,832.57	MOTOR VEHICLE REPAIR MATERIALS
9 506106451	PUBLIC WORKS	\$147.72	ELECTRIC LIGHT AND POWER
9 506106465	PUBLIC WORKS	\$370.00	AUTO + TRUCK GARAGE + OTHER
9 506106516	PUBLIC WORKS	\$361.83	UNIFORMS, RUGS ETC. RENTAL
10 509006419	FIRE DEPARTMENT	\$41,350.00	OTHER PROFESSIONAL SERVICES
10 509006443	FIRE DEPARTMENT	\$350.00	DUES, MEM. REGIS FEES, TUITION
10 509006619	FIRE DEPARTMENT	\$4,276.17	REPAYMENT OF LOAN
18 518206722	GENERAL GOVERNMENT	\$3,972.00	CLAIMS AGAINST CITY
30 2108	Liabilities	\$1,988.60	CUSTOMER DEPOSITS
30 2325	Liabilities	\$223.01	WATER METER OVERPAYMENTS
31 520106299	PUBLIC WORKS	\$278.00	OTHER OPERATING SUPPLIES
31 520106419	PUBLIC WORKS	\$66.60	OTHER PROFESSIONAL SERVICES
31 520106420	PUBLIC WORKS	\$2,370.26	CONTRACT SECURITY SERVICES

AP755
 VENDOR PAYMENTS / FOR CLAIM DOCKET - 06/27/2017
 Report Title - AMOUNTS (DESCENDING) ALL TYPES

ACCOUNT NUMBER	DEPARTMENT DESCRIPTION	AMOUNT	ACCOUNT DESCRIPTION
31 520106421	PUBLIC WORKS	\$27,654.54	POSTAGE, P O BOX RENT, ETC.
31 520106451	PUBLIC WORKS	\$184.63	ELECTRIC LIGHT AND POWER
31 520106489	PUBLIC WORKS	\$3,131.46	CONTRACT LABOR
31 520106512	PUBLIC WORKS	\$16,303.67	BUILDING RENTAL
31 520106514	PUBLIC WORKS	\$1,131.78	RENTAL OF EQUIPMENT
31 520206465	PUBLIC WORKS	\$45.00	AUTO + TRUCK GARAGE + OTHER
31 520206516	PUBLIC WORKS	\$79.91	UNIFORMS, RUGS ETC. RENTAL
31 520206865	PUBLIC WORKS	\$734.90	MISC. NON-AUTO EQUIPMENT
31 521206316	PUBLIC WORKS	\$466.99	MOTOR VEHICLE REPAIR MATERIALS
31 521206516	PUBLIC WORKS	\$10.00	UNIFORMS, RUGS ETC. RENTAL
31 521306316	PUBLIC WORKS	\$531.50	MOTOR VEHICLE REPAIR MATERIALS
31 521306317	PUBLIC WORKS	\$6,713.77	OTHER REPAIR & MAINT MATERIALS
31 521306451	PUBLIC WORKS	\$48,567.29	ELECTRIC LIGHT AND POWER
31 521306453	PUBLIC WORKS	\$593.48	GAS
31 521306514	PUBLIC WORKS	\$115.75	RENTAL OF EQUIPMENT
31 521306516	PUBLIC WORKS	\$249.92	UNIFORMS, RUGS ETC. RENTAL
31 521356231	PUBLIC WORKS	\$30,105.40	COMPUTER SOFTWARE
31 521356240	PUBLIC WORKS	\$703.08	NON-CAPITALIZED EQUIPMENT
31 521356316	PUBLIC WORKS	\$407.02	MOTOR VEHICLE REPAIR MATERIALS
31 521356419	PUBLIC WORKS	\$1,070.25	OTHER PROFESSIONAL SERVICES
31 521356420	PUBLIC WORKS	\$3,414.48	CONTRACT SECURITY SERVICE
31 521356451	PUBLIC WORKS	\$88,539.86	ELECTRIC LIGHT AND POWER
31 521356461	PUBLIC WORKS	\$7,975.00	BUILDINGS MAINTENANCE
31 521356464	PUBLIC WORKS	\$1,644.74	MACHINE/EQUIP MAINTENANCE
31 521356497	PUBLIC WORKS	\$5,166.75	SLUDGE DISPOSAL
31 521356514	PUBLIC WORKS	\$29,183.64	RENTAL OF EQUIPMENT
31 521356516	PUBLIC WORKS	\$165.59	UNIFORMS, RUGS ETC. RENTAL
31 521356865	PUBLIC WORKS	\$2,197.86	MISC. NON-AUTO EQUIPMENT
31 521406316	PUBLIC WORKS	\$8,293.27	MOTOR VEHICLE REPAIR MATERIALS
31 521406317	PUBLIC WORKS	\$549.05	OTHER REPAIR & MAINT MATERIALS
31 521406465	PUBLIC WORKS	\$725.00	AUTO + TRUCK GARAGE + OTHER
31 521406516	PUBLIC WORKS	\$373.64	UNIFORMS, RUGS ETC. RENTAL
31 521506316	PUBLIC WORKS	\$32.11	MOTOR VEHICLE REPAIR MATERIALS
31 521506516	PUBLIC WORKS	\$280.19	UNIFORMS, RUGS ETC. RENTAL
31 52156316	PUBLIC WORKS	\$5,548.32	MOTOR VEHICLE REPAIR MATERIALS
31 522156516	PUBLIC WORKS	\$143.07	UNIFORMS, RUGS ETC. RENTAL
31 522206316	PUBLIC WORKS	\$21,437.53	MOTOR VEHICLE REPAIR MATERIALS
31 522206465	PUBLIC WORKS	\$2,375.00	AUTO + TRUCK GARAGE + OTHER
31 522306419	PUBLIC WORKS	\$45,777.68	OTHER PROFESSIONAL SERVICES
31 522306453	PUBLIC WORKS	\$68.89	GAS
31 522356419	PUBLIC WORKS	\$125.00	OTHER PROFESSIONAL SERVICES
31 522406419	PUBLIC WORKS	\$125.00	OTHER PROFESSIONAL SERVICES

AP755

VENDOR PAYMENTS / FOR CLAIM DOCKET - 06/27/2017
Report Title - AMOUNTS (DESCENDING) ALL TYPES

ACCOUNT NUMBER	DEPARTMENT DESCRIPTION	AMOUNT	ACCOUNT DESCRIPTION
31 522406451	PUBLIC WORKS	\$153.23	ELECTRIC LIGHT AND POWER
31 522806614	PUBLIC WORKS	\$1,867.27	BANK SERVICE CHARGES
32 52290205057046413	PUBLIC WORKS	\$61,647.00	ENGINEERING & ARCHITECTURAL
32 52290205057056485	PUBLIC WORKS	\$249,604.51	CONTRACT CONSTRUCTION
32 521906B01039016485	PUBLIC WORKS	\$22,572.00	CONTRACT CONSTRUCTION
32 522901B05009046413	PUBLIC WORKS	\$33,522.54	ENGINEERING & ARCHITECTURAL
32 522905B05009016485	PUBLIC WORKS	\$364,694.74	CONTRACT CONSTRUCTION
32 522907B05009016485	PUBLIC WORKS	\$12,677.00	CONTRACT CONSTRUCTION
81 599106299	HUMAN & CULTURAL SERVICES	\$859.96	OTHER OPERATING SUPPLIES
81 598106419	HUMAN & CULTURAL SERVICES	\$2,702.17	OTHER PROFESSIONAL SERVICES
81 598106420	HUMAN & CULTURAL SERVICES	\$60,281.29	CONTRACT SECURITY SERVICES
81 598106472	HUMAN & CULTURAL SERVICES	\$150.12	EMPLOYEE AUTO ALLOWANCE
81 598516227	HUMAN & CULTURAL SERVICES	\$3,248.71	SUBSISTENCE & CARE OF PERSONS
81 598726227	HUMAN & CULTURAL SERVICES	\$3,154.52	SUBSISTENCE & CARE OF PERSONS
85 809106444	PLANNING & DEVELOPMENT	\$300.00	LEGAL ADS, ADVERTISING, ETC.
85 809106473	PLANNING & DEVELOPMENT	\$581.23	TRAVEL EXPENSE - OUT OF CITY
85 809206422	PLANNING & DEVELOPMENT	\$9.11	FREIGHT EXPRESS & TRUCKING CHG
85 809206443	PLANNING & DEVELOPMENT	\$150.00	DUES, MEM. REGIS FEES, TUITION
85 809206473	PLANNING & DEVELOPMENT	\$408.00	TRAVEL EXPENSE - OUT OF CITY
85 809206514	PLANNING & DEVELOPMENT	\$546.94	RENTAL OF EQUIPMENT
85 845106485	PLANNING & DEVELOPMENT	\$26,525.90	CONTRACT CONSTRUCTION
85 855106218	PLANNING & DEVELOPMENT	\$245.82	OFFICE SUPPLIES
85 855106473	PLANNING & DEVELOPMENT	\$1,119.47	TRAVEL EXPENSE - OUT OF CITY
85 921105B70034016485	PLANNING & DEVELOPMENT	\$44,295.49	CONTRACT CONSTRUCTION
120 901106443	PLANNING & DEVELOPMENT	\$300.00	DUES, MEM. REGIS FEES, TUITION
120 901106473	PLANNING & DEVELOPMENT	\$408.00	TRAVEL EXPENSE - OUT OF CITY
125 920306419	HUMAN & CULTURAL SERVICES	\$27,093.00	OTHER PROFESSIONAL SERVICES
134 438106476	HUMAN & CULTURAL SERVICES	\$429.06	LOCAL TRAVEL MEALS-ETC.
148 44890915009016723	PUBLIC WORKS	\$46,275.00	DAMAGES, EASEMENTS + ROW
156 451906B50029016413	PUBLIC WORKS	\$5,000.00	ENGINEERING & ARCHITECTURAL
173 451355B40107016413	PUBLIC WORKS	\$1,270.57	ENGINEERING & ARCHITECTURAL
173 451355B45024016413	PUBLIC WORKS	\$1,630.69	ENGINEERING & ARCHITECTURAL
173 451355B45034016485	PUBLIC WORKS	\$201,749.58	CONTRACT CONSTRUCTION
173 451355B45034026413	PUBLIC WORKS	\$30,868.52	ENGINEERING & ARCHITECTURAL
173 451355B50063016413	PUBLIC WORKS	\$19,993.00	ENGINEERING & ARCHITECTURAL
173 451355B50159016419	PUBLIC WORKS	\$14,926.11	OTHER PROFESSIONAL SERVICES
173 451356B45017016413	PUBLIC WORKS	\$27,102.54	ENGINEERING & ARCHITECTURAL
173 451356B50007016413	PUBLIC WORKS	\$4,539.08	ENGINEERING & ARCHITECTURAL
173 451357B45007016413	PUBLIC WORKS	\$17,582.09	ENGINEERING & ARCHITECTURAL
174 944006419	PUBLIC WORKS	\$21,917.94	OTHER PROFESSIONAL SERVICES
174 944006451	PUBLIC WORKS	\$43.73	ELECTRIC LIGHT AND POWER
174 944006516	PUBLIC WORKS	\$6.32	UNIFORMS, RUGS ETC. RENTAL

AP755

VENDOR PAYMENTS / FOR CLAIM DOCKET - 06/21/2017
Report Title - AMOUNTS (DESCENDING) ALL TYPES

FILE OF THE CITY ATTORNEY
6/21/17

ACCOUNT NUMBER	DEPARTMENT DESCRIPTION	AMOUNT	ACCOUNT DESCRIPTION
175 945106419	PUBLIC WORKS	\$3,917.94	OTHER PROFESSIONAL SERVICES
187 565106215	PLANNING & DEVELOPMENT	\$2,557.19	FUEL USAGE
187 565106425	PLANNING & DEVELOPMENT	\$394,272.90	PUBLIC TRANSPORTATION
187 565106451	PLANNING & DEVELOPMENT	\$3,129.64	ELECTRIC LIGHT AND POWER
187 565206218	PLANNING & DEVELOPMENT	\$114.00	OFFICE SUPPLIES
187 565206231	PLANNING & DEVELOPMENT	\$800.00	COMPUTER SOFTWARE
187 565206419	PLANNING & DEVELOPMENT	\$1,400.00	OTHER PROFESSIONAL SERVICES
187 565206514	PLANNING & DEVELOPMENT	\$1,042.41	RENTAL OF EQUIPMENT
203 559006771	GENERAL GOVERNMENT	\$294,271.19	APPROP. CONV. + VISIT BUREAU
213 451355840087016413	PUBLIC WORKS	\$43,634.51	ENGINEERING & ARCHITECTURAL
213 451904840026016413	PUBLIC WORKS	\$2,083.30	ENGINEERING & ARCHITECTURAL
216 44890315009056413	PUBLIC WORKS	\$621.98	ENGINEERING & ARCHITECTURAL
220 577806614	PUBLIC WORKS	\$2,817.00	BANK SERVICE CHARGES
220 577856614	PUBLIC WORKS	\$2,933.00	BANK SERVICE CHARGES
223 453106512	PUBLIC WORKS	\$278.00	BUILDING RENTAL
253 511856614	DEBT SERVICE	\$850.00	BANK SERVICE CHARGES
300 443466232	GENERAL GOVERNMENT	\$495.00	PHOTO & MICROFILM SUPPLIES
300 443466512	GENERAL GOVERNMENT	\$7,573.71	BUILDING RENTAL
302 443606226	ADMINISTRATION	\$8,415.00	COMMUNICATION SUPPLIES
302 443606847	ADMINISTRATION	\$15,010.00	DATA PROCESSING EQUIPMENT

***** Grand-Total for Claims *****

=====

\$3,478,561.86

OFFICE OF THE CITY ATTORNEY
[Signature]
6/22/17

AGENDA DATE: JUNE 27, 2017

ORDER APPROVING GROSS PAYROLL INCLUDING **9943**
PAYROLL DEDUCTION CLAIMS NUMBERED TO
AND MAKING APPROPRIATION FOR THE PAYMENT THEREOF.

IT IS HEREBY ORDERED THAT PAYROLL DEDUCTION CLAIMS NUMBERED TO **9943** INCLUSIVE THEREIN, IN THE MUNICIPAL 'DOCKET OF CLAIMS', IN THE AGGREGATE AMOUNT OF \$150,060.81, PLUS PAYROLL, ARE APPROVED FOR PAYMENT AND NECESSARY AMOUNTS ARE APPROPRIATED FROM VARIOUS MUNICIPAL FUNDS FOR TRANSFER TO THE PAYROLL FUND FOR THE IMMEDIATE PAYMENT THEREOF.

IT IS FINALLY ORDERED THAT THE FOLLOWING EXPENDITURES FROM THE ACCOUNTS PAYABLE FUND BE MADE IN ORDER TO PAY AMOUNTS TRANSFERRED THERETO FROM THE PAYROLL FUND FOR PAYMENT OF THE PAYROLL DEDUCTION CLAIMS AUTHORIZED HEREIN FOR PAYMENT:

	TO	TO
	ACCOUNTS PAYABLE	PAYROLL
FROM:	FUND	FUND

PAYROLL FUND \$150,060.81

\$150,060.81
=====

APPROVED FOR AGENDA INITIALS DATE

DEPARTMENT DIRECTOR MBD 6/22/17

LEGAL [Signature] 6/22/17

CAO MKC 6/22/17

MAYOR'S OFFICE [Signature] 6/22/17

ITEM# 7

AGENDA DATE 6/27/17

BY: DAY, YARBER

AP757

VENDOR PAYMENTS / FOR CLAIM DOCKET - 06/27/2017
REPORT TITLE - AMOUNTS (DESCENDING) ALL TYPES
Invoice Payments Over \$5,000

VEN#	VENDOR-NAME	INVOICE	INV-DATE	AMOUNT	AUTHORIZATION	DUE-DATE	REF-NUMBER	PAYMENT-TYPE	REMARKS
00501	CRDU	PA71870177	06/15/2017	\$8,784.12		06/15/2017		R&R-Invoice	Payroll Generated Invoice
00501	CRDU	PA71870183	06/15/2017	\$8,297.57		06/15/2017		R&R-Invoice	Payroll Generated Invoice
00726	JAMES L HENLEY	PA71870468	06/15/2017	\$5,301.50		06/15/2017		R&R-Invoice	Payroll Generated Invoice
00523	AFLAC	PA71870249	06/15/2017	\$5,131.85		06/15/2017		R&R-Invoice	Payroll Generated Invoice

*** Payments Over \$5,000 Total ***
\$27,515.04

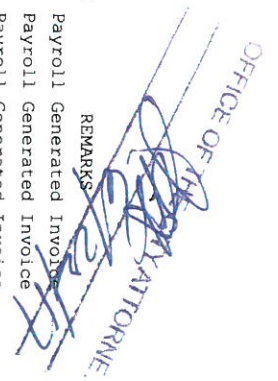
OFFICE OF THE ATTORNEY

VENDOR PAYMENTS / FOR CLAIM DOCKET - 06/27/2017
 REPORT TITLE - AMOUNTS (DESCENDING) ALL TYPES
 Invoice Payments Under \$5,000 - Over \$500

AP757

VEN#	VENDOR-NAME	INVOICE	INV-DATE	AMOUNT	AUTHORIZATION	DUE-DATE	REF-NUMBER	PAYMENT-TYPE	REMARKS
00523	AFLAC	PA71870250	06/15/2017	\$4,221.09		06/15/2017		R&R-Invoice	Payroll Generated Invoice
00857	JACKSON POLICE OFFICERS ASSOC	PA71870540	06/15/2017	\$3,785.20		06/15/2017		R&R-Invoice	Payroll Generated Invoice
00442	HAROLD J BARKLEY JR, TRUSTEE	PA71870117	06/15/2017	\$3,426.50		06/15/2017		R&R-Invoice	Payroll Generated Invoice
00523	AFLAC	PA71870232	06/15/2017	\$3,156.01		06/15/2017		R&R-Invoice	Payroll Generated Invoice
00523	AFLAC	PA71870233	06/15/2017	\$2,805.10		06/15/2017		R&R-Invoice	Payroll Generated Invoice
00442	HAROLD J BARKLEY JR, TRUSTEE	PA71870115	06/15/2017	\$2,265.50		06/15/2017		R&R-Invoice	Payroll Generated Invoice
00848	JACKSON FIREFIGHTERS ASSOC	PA71870534	06/15/2017	\$2,182.02		06/15/2017		R&R-Invoice	Payroll Generated Invoice
00432	H D CATCHINGS AGENCY	PA71870072	06/15/2017	\$2,080.40		06/15/2017		R&R-Invoice	Payroll Generated Invoice
70874	SOUTHERN STATES POLICE BENEVL	PA71870927	06/15/2017	\$1,659.82		06/15/2017		R&R-Invoice	Payroll Generated Invoice
00653	AMERICAN-AMICABLE LIFE INSURAN	PA71870396	06/15/2017	\$1,637.37		06/15/2017		R&R-Invoice	Payroll Generated Invoice
00529	POLICE HOSPITAL FUND	PA71870315	06/15/2017	\$1,173.48		06/15/2017		R&R-Invoice	Payroll Generated Invoice
00765	AMERICAN HERITAGE LIFE INSURAN	PA71870508	06/15/2017	\$1,127.67		06/15/2017		R&R-Invoice	Payroll Generated Invoice
00653	AMERICAN-AMICABLE LIFE INSURAN	PA71870392	06/15/2017	\$1,099.14		06/15/2017		R&R-Invoice	Payroll Generated Invoice
65572	UNUM PROVIDENT LIFE & ACCIDENT	PA71870730	06/15/2017	\$1,061.22		06/15/2017		R&R-Invoice	Payroll Generated Invoice
00726	JAMES L HENLEY	PA71870474	06/15/2017	\$1,019.00		06/15/2017		R&R-Invoice	Payroll Generated Invoice
00448	PENNSYLVANIA LIFE INSURANCE CO	PA71870136	06/15/2017	\$1,010.96		06/15/2017		R&R-Invoice	Payroll Generated Invoice
00640	TUCKER JOHN E	PA71870374	06/15/2017	\$928.25		06/15/2017		R&R-Invoice	Payroll Generated Invoice
00501	CRDU	PA71870201	06/15/2017	\$890.23		06/15/2017		R&R-Invoice	Payroll Generated Invoice
00442	HAROLD J BARKLEY JR, TRUSTEE	PA71870116	06/15/2017	\$808.00		06/15/2017		R&R-Invoice	Payroll Generated Invoice
00448	PENNSYLVANIA LIFE INSURANCE CO	PA71870131	06/15/2017	\$775.16		06/15/2017		R&R-Invoice	Payroll Generated Invoice
00499	MS DEPARTMENT OF REVENUE (DOR)	PA71870170	06/15/2017	\$774.14		06/15/2017		R&R-Invoice	Payroll Generated Invoice
00794	NATIONAL PAYMENT CENTER	PA71870532	06/15/2017	\$747.21		06/15/2017		R&R-Invoice	Payroll Generated Invoice
71144	YOUNG WELLS WILLIAMS, P.A.	PA71870931	06/15/2017	\$739.39		06/15/2017		R&R-Invoice	Payroll Generated Invoice
00501	CRDU	PA71870182	06/15/2017	\$721.83		06/15/2017		R&R-Invoice	Payroll Generated Invoice
00726	JAMES L HENLEY	PA71870469	06/15/2017	\$675.50		06/15/2017		R&R-Invoice	Payroll Generated Invoice
00442	HAROLD J BARKLEY JR, TRUSTEE	PA71870122	06/15/2017	\$660.00		06/15/2017		R&R-Invoice	Payroll Generated Invoice
00418	COURTNEY & CAMP	PA71870047	06/15/2017	\$621.38		06/15/2017		R&R-Invoice	Payroll Generated Invoice
60028	3P BENEFIT SOLUTIONS LLC	PA71870688	06/15/2017	\$619.73		06/15/2017		R&R-Invoice	Payroll Generated Invoice
60028	3P BENEFIT SOLUTIONS LLC	PA71870692	06/15/2017	\$607.30		06/15/2017		R&R-Invoice	Payroll Generated Invoice
00726	JAMES L HENLEY	PA71870466	06/15/2017	\$606.00		06/15/2017		R&R-Invoice	Payroll Generated Invoice
00442	HAROLD J BARKLEY JR, TRUSTEE	PA71870121	06/15/2017	\$585.50		06/15/2017		R&R-Invoice	Payroll Generated Invoice
00653	AMERICAN-AMICABLE LIFE INSURAN	PA71870388	06/15/2017	\$568.14		06/15/2017		R&R-Invoice	Payroll Generated Invoice
00651	SIMPSON LAW FIRM PA	PA71870378	06/15/2017	\$557.49		06/15/2017		R&R-Invoice	Payroll Generated Invoice
00765	AMERICAN HERITAGE LIFE INSURAN	PA71870501	06/15/2017	\$555.18		06/15/2017		R&R-Invoice	Payroll Generated Invoice
00499	MS DEPARTMENT OF REVENUE (DOR)	PA71870172	06/15/2017	\$551.53		06/15/2017		R&R-Invoice	Payroll Generated Invoice
00415	LIFE OF ALABAMA	PA71870024	06/15/2017	\$537.39		06/15/2017		R&R-Invoice	Payroll Generated Invoice
60028	3P BENEFIT SOLUTIONS LLC	PA71870691	06/15/2017	\$535.36		06/15/2017		R&R-Invoice	Payroll Generated Invoice
00415	LIFE OF ALABAMA	PA71870023	06/15/2017	\$534.48		06/15/2017		R&R-Invoice	Payroll Generated Invoice
00449	THRASH GARY	PA71870147	06/15/2017	\$522.13		06/15/2017		R&R-Invoice	Payroll Generated Invoice
00938	HENLEY BRAND	PA71870614	06/15/2017	\$501.29		06/15/2017		R&R-Invoice	Payroll Generated Invoice

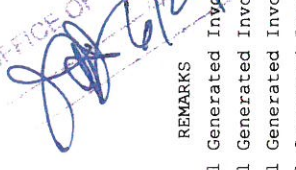
OFFICE OF THE CITY ATTORNEY

VENDOR PAYMENTS / FOR CLAIM DOCKET - 06/27/2017
 REPORT TITLE - AMOUNTS (DESCENDING) ALL TYPES
 Invoice Payments Under \$500

VEN#	VENDOR-NAME	INVOICE	INV-DATE	AMOUNT	AUTHORIZATION	DUE-DATE	REF-NUMBER	PAYMENT-TYPE	REMARKS
00726	JAMES L HENLEY	PA71870467	06/15/2017	\$477.50		06/15/2017		R&R-Invoice	Payroll Generated Invoice
00501	CRDU	PA71870179	06/15/2017	\$475.87		06/15/2017		R&R-Invoice	Payroll Generated Invoice
00501	CRDU	PA71870176	06/15/2017	\$455.28		06/15/2017		R&R-Invoice	Payroll Generated Invoice
00501	CRDU	PA71870174	06/15/2017	\$452.35		06/15/2017		R&R-Invoice	Payroll Generated Invoice
00499	MS DEPARTMENT OF REVENUE (DOR)	PA71870171	06/15/2017	\$444.37		06/15/2017		R&R-Invoice	Payroll Generated Invoice
00501	CRDU	PA71870175	06/15/2017	\$438.96		06/15/2017		R&R-Invoice	Payroll Generated Invoice
00449	THRASH GARY	PA71870151	06/15/2017	\$432.94		06/15/2017		R&R-Invoice	Payroll Generated Invoice
60028	3P BENEFIT SOLUTIONS LLC	PA71870684	06/15/2017	\$425.31		06/15/2017		R&R-Invoice	Payroll Generated Invoice
00501	CRDU	PA71870195	06/15/2017	\$421.65		06/15/2017		R&R-Invoice	Payroll Generated Invoice
00653	AMERICAN-AMICABLE LIFE INSURAN	PA71870407	06/15/2017	\$418.01		06/15/2017		R&R-Invoice	Payroll Generated Invoice
66394	COMPBENEFITS	PA71870825	06/15/2017	\$413.79		06/15/2017		R&R-Invoice	Payroll Generated Invoice
00657	COLONIAL LIFE & ACCIDENT CO.	PA71870437	06/15/2017	\$411.06		06/15/2017		R&R-Invoice	Payroll Generated Invoice
00726	JAMES L HENLEY	PA71870473	06/15/2017	\$402.00		06/15/2017		R&R-Invoice	Payroll Generated Invoice
00442	HAROLD J BARKLEY JR, TRUSTEE	PA71870113	06/15/2017	\$390.00		06/15/2017		R&R-Invoice	Payroll Generated Invoice
65703	REPUBLIC FINANCE INC	PA71870742	06/15/2017	\$384.05		06/15/2017		R&R-Invoice	Payroll Generated Invoice
00449	THRASH GARY	PA71870146	06/15/2017	\$382.16		06/15/2017		R&R-Invoice	Payroll Generated Invoice
00501	CRDU	PA71870193	06/15/2017	\$381.55		06/15/2017		R&R-Invoice	Payroll Generated Invoice
00794	NATIONAL PAYMENT CENTER	PA71870531	06/15/2017	\$378.03		06/15/2017		R&R-Invoice	Payroll Generated Invoice
00501	CRDU	PA71870192	06/15/2017	\$377.56		06/15/2017		R&R-Invoice	Payroll Generated Invoice
00432	H D CATCHINGS AGENCY	PA71870065	06/15/2017	\$373.78		06/15/2017		R&R-Invoice	Payroll Generated Invoice
00523	AFLAC	PA71870244	06/15/2017	\$371.82		06/15/2017		R&R-Invoice	Payroll Generated Invoice
70781	DELTA MANAGEMENT ASSOCIATES	PA71870923	06/15/2017	\$370.85		06/15/2017		R&R-Invoice	Payroll Generated Invoice
66394	COMPBENEFITS	PA71870803	06/15/2017	\$360.74		06/15/2017		R&R-Invoice	Payroll Generated Invoice
01008	TOWER LOAN OD NORTH JACKSON	PA71870636	06/15/2017	\$353.05		06/15/2017		R&R-Invoice	Payroll Generated Invoice
65572	UNUM PROVIDENT LIFE & ACCIDENT	PA71870729	06/15/2017	\$350.89		06/15/2017		R&R-Invoice	Payroll Generated Invoice
00501	CRDU	PA71870204	06/15/2017	\$342.95		06/15/2017		R&R-Invoice	Payroll Generated Invoice
65937	MENDELSON LAW FIRM	PA71870745	06/15/2017	\$342.01		06/15/2017		R&R-Invoice	Payroll Generated Invoice
60028	3P BENEFIT SOLUTIONS LLC	PA71870665	06/15/2017	\$341.32		06/15/2017		R&R-Invoice	Payroll Generated Invoice
60028	3P BENEFIT SOLUTIONS LLC	PA71870664	06/15/2017	\$334.07		06/15/2017		R&R-Invoice	Payroll Generated Invoice
00726	JAMES L HENLEY	PA71870471	06/15/2017	\$333.00		06/15/2017		R&R-Invoice	Payroll Generated Invoice
00746	BARBOUR IV JEPHTHA F	PA71870481	06/15/2017	\$331.66		06/15/2017		R&R-Invoice	Payroll Generated Invoice
00501	CRDU	PA71640032	06/09/2017	\$330.25		06/09/2017		R&R-Invoice	Payroll Generated Invoice
00501	CRDU	PA71880032	06/16/2017	\$330.25		06/16/2017		R&R-Invoice	Payroll Generated Invoice
00442	HAROLD J BARKLEY JR, TRUSTEE	PA71870114	06/15/2017	\$328.00		06/15/2017		R&R-Invoice	Payroll Generated Invoice
00523	AFLAC	PA71870243	06/15/2017	\$326.47		06/15/2017		R&R-Invoice	Payroll Generated Invoice
00944	PRE-PAID LEGAL SERVICES INC	PA71870623	06/15/2017	\$319.96		06/15/2017		R&R-Invoice	Payroll Generated Invoice
00415	LIFE OF ALABAMA	PA71870041	06/15/2017	\$316.08		06/15/2017		R&R-Invoice	Payroll Generated Invoice
00501	CRDU	PA71870187	06/15/2017	\$316.41		06/15/2017		R&R-Invoice	Payroll Generated Invoice
65234	ROBERT W CAMP, ATTY	PA71870712	06/15/2017	\$314.48		06/15/2017		R&R-Invoice	Payroll Generated Invoice
00908	A-1 CHECK CASHING INC	PA71870606	06/15/2017	\$313.66		06/15/2017		R&R-Invoice	Payroll Generated Invoice
00944	PRE-PAID LEGAL SERVICES INC	PA71870621	06/15/2017	\$310.04		06/15/2017		R&R-Invoice	Payroll Generated Invoice
00449	THRASH GARY	PA71870149	06/15/2017	\$304.35		06/15/2017		R&R-Invoice	Payroll Generated Invoice
00523	AFLAC	PA71870225	06/15/2017	\$303.02		06/15/2017		R&R-Invoice	Payroll Generated Invoice

AP757

VENDOR PAYMENTS / FOR CLAIM DOCKET - 06/27/2017

REPORT TITLE - AMOUNTS (DESCENDING) ALL TYPES

Invoice Payments Under \$500

VEN#	VENDOR-NAME	INVOICE	INV-DATE	AMOUNT	AUTHORIZATION	DUE-DATE	REF-NUMBER	PAYMENT-TYPE	REMARKS
00523	AFLAC	PA71870248	06/15/2017	\$302.72		06/15/2017		R&R-Invoice	Payroll Generated Invoice
00726	JAMES L HENLEY	PA71870472	06/15/2017	\$300.50		06/15/2017		R&R-Invoice	Payroll Generated Invoice
71513	FAMILY SUPPORT REGISTRY	PA71870933	06/15/2017	\$299.09		06/15/2017		R&R-Invoice	Payroll Generated Invoice
00432	H D CATCHINGS AGENCY	PA71870070	06/15/2017	\$295.37		06/15/2017		R&R-Invoice	Payroll Generated Invoice
00501	CRDU	PA71870185	06/15/2017	\$291.72		06/15/2017		R&R-Invoice	Payroll Generated Invoice
71941	ARP HARDY	PA71870942	06/15/2017	\$291.81		06/15/2017		R&R-Invoice	Payroll Generated Invoice
00985	TOWER LOAN OF SW JACKSON	PA71870634	06/15/2017	\$290.45		06/15/2017		R&R-Invoice	Payroll Generated Invoice
00501	CRDU	PA71870196	06/15/2017	\$289.97		06/15/2017		R&R-Invoice	Payroll Generated Invoice
00501	CRDU	PA71870181	06/15/2017	\$288.55		06/15/2017		R&R-Invoice	Payroll Generated Invoice
00449	THRASH GARY	PA71870150	06/15/2017	\$286.50		06/15/2017		R&R-Invoice	Payroll Generated Invoice
00884	SANDERS ANTONETTE LEQUISHA	PA71870603	06/15/2017	\$286.15		06/15/2017		R&R-Invoice	Payroll Generated Invoice
60028	3P BENEFIT SOLUTIONS LLC	PA71870675	06/15/2017	\$286.14		06/15/2017		R&R-Invoice	Payroll Generated Invoice
00501	CRDU	PA71870190	06/15/2017	\$285.71		06/15/2017		R&R-Invoice	Payroll Generated Invoice
00657	COLONIAL LIFE & ACCIDENT CO.	PA71870429	06/15/2017	\$283.36		06/15/2017		R&R-Invoice	Payroll Generated Invoice
00746	BARBOUR IV JEPHTHA F	PA71870479	06/15/2017	\$280.14		06/15/2017		R&R-Invoice	Payroll Generated Invoice
66394	COMPBENEFITS	PA71870823	06/15/2017	\$277.97		06/15/2017		R&R-Invoice	Payroll Generated Invoice
00877	MASE/CWA	PA71870359	06/15/2017	\$271.50		06/15/2017		R&R-Invoice	Payroll Generated Invoice
00640	TUCKER JOHN E	PA71870375	06/15/2017	\$269.07		06/15/2017		R&R-Invoice	Payroll Generated Invoice
00449	THRASH GARY	PA71870156	06/15/2017	\$266.20		06/15/2017		R&R-Invoice	Payroll Generated Invoice
66394	COMPBENEFITS	PA71870824	06/15/2017	\$266.77		06/15/2017		R&R-Invoice	Payroll Generated Invoice
00618	HENLEY PAT	PA71870372	06/15/2017	\$263.38		06/15/2017		R&R-Invoice	Payroll Generated Invoice
00873	PIONEER CREDIT COMPANY	PA71870543	06/15/2017	\$262.93		06/15/2017		R&R-Invoice	Payroll Generated Invoice
00764	OCCIDENTAL LIFE INSURANCE CO	PA71870489	06/15/2017	\$258.54		06/15/2017		R&R-Invoice	Payroll Generated Invoice
00794	NATIONAL PAYMENT CENTER	PA71870530	06/15/2017	\$256.53		06/15/2017		R&R-Invoice	Payroll Generated Invoice
00746	BARBOUR IV JEPHTHA F	PA71870482	06/15/2017	\$255.64		06/15/2017		R&R-Invoice	Payroll Generated Invoice
00523	AFLAC	PA71870224	06/15/2017	\$253.00		06/15/2017		R&R-Invoice	Payroll Generated Invoice
00501	CRDU	PA71640035	06/09/2017	\$251.03		06/09/2017		R&R-Invoice	Payroll Generated Invoice
00501	CRDU	PA71880035	06/16/2017	\$251.03		06/16/2017		R&R-Invoice	Payroll Generated Invoice
00653	AMERICAN-AMICABLE LIFE INSURAN	PA71870408	06/15/2017	\$250.00		06/15/2017		R&R-Invoice	Payroll Generated Invoice
72593	FINKELSTEIN KERN STEINBERG & C	PA71870946	06/15/2017	\$249.21		06/15/2017		R&R-Invoice	Payroll Generated Invoice
71556	WILKINSON ATTORNEYS AT LAW	PA71870934	06/15/2017	\$248.14		06/15/2017		R&R-Invoice	Payroll Generated Invoice
00499	MS DEPARTMENT OF REVENUE (DOR)	PA71640030	06/09/2017	\$247.26		06/09/2017		R&R-Invoice	Payroll Generated Invoice
65572	UNUM PROVIDENT LIFE & ACCIDENT	PA71870724	06/15/2017	\$247.89		06/15/2017		R&R-Invoice	Payroll Generated Invoice
00523	AFLAC	PA71870247	06/15/2017	\$244.50		06/15/2017		R&R-Invoice	Payroll Generated Invoice
00432	H D CATCHINGS AGENCY	PA71870067	06/15/2017	\$243.13		06/15/2017		R&R-Invoice	Payroll Generated Invoice
00850	TOWER LOAN OF RICHLAND	PA71870539	06/15/2017	\$242.82		06/15/2017		R&R-Invoice	Payroll Generated Invoice
00653	AMERICAN-AMICABLE LIFE INSURAN	PA71870395	06/15/2017	\$239.54		06/15/2017		R&R-Invoice	Payroll Generated Invoice
00418	COURTNEY & CAMP	PA71870048	06/15/2017	\$238.92		06/15/2017		R&R-Invoice	Payroll Generated Invoice
00490	MS TELCO FEDERAL CREDIT UNION	PA71870168	06/15/2017	\$237.34		06/15/2017		R&R-Invoice	Payroll Generated Invoice
00746	BARBOUR IV JEPHTHA F	PA71870480	06/15/2017	\$237.41		06/15/2017		R&R-Invoice	Payroll Generated Invoice
00618	HENLEY PAT	PA71870373	06/15/2017	\$235.28		06/15/2017		R&R-Invoice	Payroll Generated Invoice
01051	NC CHILD SUPPORT & CENTRALIZED	PA71870641	06/15/2017	\$235.38		06/15/2017		R&R-Invoice	Payroll Generated Invoice
00873	PIONEER CREDIT COMPANY	PA06122017	06/12/2017	\$234.66		06/27/2017		R&R-Invoice	VINSON HUGHES

AP757
 VENDOR PAYMENTS / FOR CLAIM DOCKET - 06/27/2017
 REPORT TITLE - AMOUNTS (DESCENDING) ALL TYPES
 Invoice Payments Under \$500

VEN#	VENDOR-NAME	INVOICE	INV-DATE	AMOUNT	AUTHORIZATION	DUE-DATE	REF-NUMBER	PAYMENT-TYPE	REMARKS
00935	STEADMAN SUSAN	PA71870612	06/15/2017	\$234.34		06/15/2017		R&R-Invoice	Payroll Generated Invoice
66425	PIIONEER CREDIT RECOVERY, INC	PA71870919	06/15/2017	\$231.66		06/15/2017		R&R-Invoice	Payroll Generated Invoice
67435	GARDNER STEPHEN E	PA71870921	06/15/2017	\$231.13		06/15/2017		R&R-Invoice	Payroll Generated Invoice
00449	THRASH GARY	PA71870145	06/15/2017	\$230.82		06/15/2017		R&R-Invoice	Payroll Generated Invoice
00457	REEVES JOHN R	PA71870159	06/15/2017	\$230.30		06/15/2017		R&R-Invoice	Payroll Generated Invoice
00432	H D CATCHINGS AGENCY	PA71870057	06/15/2017	\$227.67		06/15/2017		R&R-Invoice	Payroll Generated Invoice
00529	POLICE HOSPITAL FUND	PA71870307	06/15/2017	\$226.38		06/15/2017		R&R-Invoice	Payroll Generated Invoice
00501	CRDU	PA71870189	06/15/2017	\$222.01		06/15/2017		R&R-Invoice	Payroll Generated Invoice
00743	HART ANGELA	PA71870476	06/15/2017	\$222.92		06/15/2017		R&R-Invoice	Payroll Generated Invoice
63884	BENDER TERESA	PA41040759	01/29/2015	\$222.50		01/29/2015		R&R-Invoice	Payroll Generated Invoice
71131	INTERNAL REVENUE SERVICE	PA71870929	06/15/2017	\$222.00		06/15/2017		R&R-Invoice	Payroll Generated Invoice
00937	TOWER LOAN OF CLINTON	PA71870613	06/15/2017	\$220.85		06/15/2017		R&R-Invoice	Payroll Generated Invoice
00938	HENLEY BRAND	PA71870617	06/15/2017	\$216.64		06/15/2017		R&R-Invoice	Payroll Generated Invoice
00909	CLERK UNITED STATES DISTRICT	PA71870608	06/15/2017	\$215.75		06/15/2017		R&R-Invoice	Payroll Generated Invoice
01064	CANNON MOTOR COMPANY	PA71870642	06/15/2017	\$215.49		06/15/2017		R&R-Invoice	Payroll Generated Invoice
71661	MITCHELL MCNUTT AND SAMS PA	PA71870937	06/15/2017	\$215.02		06/15/2017		R&R-Invoice	Payroll Generated Invoice
00501	CRDU	PA71870197	06/15/2017	\$215.00		06/15/2017		R&R-Invoice	Payroll Generated Invoice
01032	MILWAUKEE CO CHILD SUPPORT	PA71870640	06/15/2017	\$207.69		06/15/2017		R&R-Invoice	Payroll Generated Invoice
00651	SIMPSON LAW FIRM PA	PA71870377	06/15/2017	\$203.06		06/15/2017		R&R-Invoice	Payroll Generated Invoice
00653	AMERICAN-AMICABLE LIFE INSURAN	PA71870393	06/15/2017	\$203.15		06/15/2017		R&R-Invoice	Payroll Generated Invoice
64052	MATTHEWS TIEFFANY	PA71870710	06/15/2017	\$202.50		06/15/2017		R&R-Invoice	Payroll Generated Invoice
00501	CRDU	PA71870198	06/15/2017	\$196.17		06/15/2017		R&R-Invoice	Payroll Generated Invoice
00449	THRASH GARY	PA71870153	06/15/2017	\$193.36		06/15/2017		R&R-Invoice	Payroll Generated Invoice
60028	3P BENEFIT SOLUTIONS LLC	PA71870685	06/15/2017	\$192.00		06/15/2017		R&R-Invoice	Payroll Generated Invoice
00432	H D CATCHINGS AGENCY	PA71870060	06/15/2017	\$190.93		06/15/2017		R&R-Invoice	Payroll Generated Invoice
00449	THRASH GARY	PA71870155	06/15/2017	\$190.08		06/15/2017		R&R-Invoice	Payroll Generated Invoice
00985	TOWER LOAN OF SW JACKSON	PA71870633	06/15/2017	\$190.12		06/15/2017		R&R-Invoice	Payroll Generated Invoice
71401	AGE CHECK ADVANCE	PA71870932	06/15/2017	\$190.39		06/15/2017		R&R-Invoice	Payroll Generated Invoice
00657	COLONIAL LIFE & ACCIDENT CO.	PA71870422	06/15/2017	\$186.55		06/15/2017		R&R-Invoice	Payroll Generated Invoice
00889	DEPARTMENT OF SOCIAL SERVICES	PA71870604	06/15/2017	\$185.52		06/15/2017		R&R-Invoice	Payroll Generated Invoice
65703	REPUBLIC FINANCE INC	PA71870744	06/15/2017	\$185.80		06/15/2017		R&R-Invoice	Payroll Generated Invoice
00657	COLONIAL LIFE & ACCIDENT CO.	PA71870436	06/15/2017	\$184.86		06/15/2017		R&R-Invoice	Payroll Generated Invoice
71919	GALLION WILLIEESTINE	PA71870941	06/15/2017	\$184.61		06/15/2017		R&R-Invoice	Payroll Generated Invoice
00432	H D CATCHINGS AGENCY	PA71870098	06/15/2017	\$183.44		06/15/2017		R&R-Invoice	Payroll Generated Invoice
00501	CRDU	PA71870203	06/15/2017	\$183.70		06/15/2017		R&R-Invoice	Payroll Generated Invoice
00938	HENLEY BRAND	PA71870188	06/15/2017	\$179.50		06/15/2017		R&R-Invoice	Payroll Generated Invoice
00882	BANKS CAPRICE	PA71870602	06/15/2017	\$176.35		06/15/2017		R&R-Invoice	Payroll Generated Invoice
00449	THRASH GARY	PA71870148	06/15/2017	\$174.18		06/15/2017		R&R-Invoice	Payroll Generated Invoice
00499	MS DEPARTMENT OF REVENUE (DOR)	PA71870169	06/15/2017	\$171.43		06/15/2017		R&R-Invoice	Payroll Generated Invoice
01008	TOWER LOAN OD NORTH JACKSON	PA71870637	06/15/2017	\$167.42		06/15/2017		R&R-Invoice	Payroll Generated Invoice
71131	INTERNAL REVENUE SERVICE	PA71870930	06/15/2017	\$167.18		06/15/2017		R&R-Invoice	Payroll Generated Invoice
00415	LIFE OF ALABAMA	PA71870019	06/15/2017	\$163.51		06/15/2017		R&R-Invoice	Payroll Generated Invoice

AP757

VENDOR PAYMENTS / FOR CLAIM DOCKET - 06/27/2017
REPORT TITLE - AMOUNTS (DESCENDING) ALL TYPES
Invoice Payments Under \$500

VEN#	VENDOR-NAME	INVOICE	INV-DATE	AMOUNT	AUTHORIZATION	DUE-DATE	REF-NUMBER	PAYMENT-TYPE	REMARKS
00985	TOWER LOAN OF SW JACKSON	PA71870635	06/15/2017	\$163.09		06/15/2017		R&R-Invoice	Payroll Generated Invoice
00442	HAROLD J BARKLEY JR, TRUSTEE	PA71870120	06/15/2017	\$161.50		06/15/2017		R&R-Invoice	Payroll Generated Invoice
00922	HARRIS MICHELLE	PA71870610	06/15/2017	\$161.54		06/15/2017		R&R-Invoice	Payroll Generated Invoice
00959	KENDRICK MELANIE FAYE	PA71870630	06/15/2017	\$161.53		06/15/2017		R&R-Invoice	Payroll Generated Invoice
00445	J ALLEN SANDIFER AGENCY	PA71870124	06/15/2017	\$160.03		06/15/2017		R&R-Invoice	Payroll Generated Invoice
00765	AMERICAN HERITAGE LIFE INSURAN	PA71870509	06/15/2017	\$160.62		06/15/2017		R&R-Invoice	Payroll Generated Invoice
00449	THRASH GARY	PA71870144	06/15/2017	\$159.01		06/15/2017		R&R-Invoice	Payroll Generated Invoice
00449	THRASH GARY	PA71870157	06/15/2017	\$159.20		06/15/2017		R&R-Invoice	Payroll Generated Invoice
00653	AMERICAN-AMICABLE LIFE INSURAN	PA71870386	06/15/2017	\$159.44		06/15/2017		R&R-Invoice	Payroll Generated Invoice
00432	H D CATCHINGS AGENCY	PA71870105	06/15/2017	\$157.75		06/15/2017		R&R-Invoice	Payroll Generated Invoice
00726	JAMES L HENLEY	PA71870470	06/15/2017	\$157.50		06/15/2017		R&R-Invoice	Payroll Generated Invoice
00726	JAMES L HENLEY	PA71870475	06/15/2017	\$158.00		06/15/2017		R&R-Invoice	Payroll Generated Invoice
01020	PERFORMANT RECOVERY INC	PA71870639	06/15/2017	\$156.82		06/15/2017		R&R-Invoice	Payroll Generated Invoice
00415	LIFE OF ALABAMA	PA71870043	06/15/2017	\$154.02		06/15/2017		R&R-Invoice	Payroll Generated Invoice
00808	DARLENE HILL	PA71870533	06/15/2017	\$155.00		06/15/2017		R&R-Invoice	Payroll Generated Invoice
00764	OCCIDENTAL LIFE INSURANCE CO	PA71870485	06/15/2017	\$152.79		06/15/2017		R&R-Invoice	Payroll Generated Invoice
00832	SHERETHA L MCGRUDER	PA41040594	01/29/2015	\$152.50		01/29/2015		R&R-Invoice	Payroll Generated Invoice
00651	SIMPSON LAW FIRM PA	PA71870380	06/15/2017	\$150.07		06/15/2017		R&R-Invoice	Payroll Generated Invoice
00449	THRASH GARY	PA71870154	06/15/2017	\$150.00		06/15/2017		R&R-Invoice	Payroll Generated Invoice
00938	HENLEY BRAND	PA71870615	06/15/2017	\$150.00		06/15/2017		R&R-Invoice	Payroll Generated Invoice
01009	WALLER & WALLER	PA71870638	06/15/2017	\$148.97		06/15/2017		R&R-Invoice	Payroll Generated Invoice
00415	LIFE OF ALABAMA	PA71870021	06/15/2017	\$147.84		06/15/2017		R&R-Invoice	Payroll Generated Invoice
00529	POLICE HOSPITAL FUND	PA71870313	06/15/2017	\$147.84		06/15/2017		R&R-Invoice	Payroll Generated Invoice
00867	SANDERS TARA B	PA71870541	06/15/2017	\$147.69		06/15/2017		R&R-Invoice	Payroll Generated Invoice
00969	FRAZIER SONYA MOZELLA	PA71870632	06/15/2017	\$147.38		06/15/2017		R&R-Invoice	Payroll Generated Invoice
00415	LIFE OF ALABAMA	PA71870045	06/15/2017	\$146.60		06/15/2017		R&R-Invoice	Payroll Generated Invoice
00501	CRDU	PA71870184	06/15/2017	\$146.32		06/15/2017		R&R-Invoice	Payroll Generated Invoice
00877	MASE/CWA	PA71870556	06/15/2017	\$146.92		06/15/2017		R&R-Invoice	Payroll Generated Invoice
00501	CRDU	PA71870200	06/15/2017	\$143.07		06/15/2017		R&R-Invoice	Payroll Generated Invoice
00523	AFAC	PA71870245	06/15/2017	\$143.11		06/15/2017		R&R-Invoice	Payroll Generated Invoice
00401	ALLIED INTERSTATE INC	PA71870001	06/15/2017	\$142.14		06/15/2017		R&R-Invoice	Payroll Generated Invoice
60028	3P BENEFIT SOLUTIONS LLC	PA71870676	06/15/2017	\$142.15		06/15/2017		R&R-Invoice	Payroll Generated Invoice
66091	ALABAMA CHILD SUPPORT CENTER	PA71870748	06/15/2017	\$141.92		06/15/2017		R&R-Invoice	Payroll Generated Invoice
66394	COMPENEFITS	PA71870801	06/15/2017	\$140.79		06/15/2017		R&R-Invoice	Payroll Generated Invoice
00415	LIFE OF ALABAMA	PA71870009	06/15/2017	\$139.84		06/15/2017		R&R-Invoice	Payroll Generated Invoice
65250	INA TAYLOR	PA71870713	06/15/2017	\$139.93		06/15/2017		R&R-Invoice	Payroll Generated Invoice
00914	AKILAH IFE RICHARDSON	PA71870609	06/15/2017	\$138.46		06/15/2017		R&R-Invoice	Payroll Generated Invoice
66017	FORBES EUNICE	PA71870747	06/15/2017	\$138.46		06/15/2017		R&R-Invoice	Payroll Generated Invoice
71331	HEWITT LISA	PA41041004	01/29/2015	\$138.47		01/29/2015		R&R-Invoice	Payroll Generated Invoice
71585	MCGEE LATRINA	PA71870936	06/15/2017	\$138.46		06/15/2017		R&R-Invoice	Payroll Generated Invoice
71814	LEWIS ESCORTIA	PA71870939	06/15/2017	\$138.46		06/15/2017		R&R-Invoice	Payroll Generated Invoice
00783	LAWANDA BAILEY HARRIS	PA71870529	06/15/2017	\$137.50		06/15/2017		R&R-Invoice	Payroll Generated Invoice
66375	BYRD STEPHANIE	PA71870751	06/15/2017	\$137.50		06/15/2017		R&R-Invoice	Payroll Generated Invoice

AP157

VENDOR PAYMENTS / FOR CLAIM DOCKET - 06/27/2017
REPORT TITLE - AMOUNTS (DESCENDING) ALL TYPES
Invoice Payments Under \$500

VEN#	VENDOR-NAME	INVOICE	INV-DATE	AMOUNT	AUTHORIZATION	DUE-DATE	REF-NUMBER	PAYMENT-TYPE	REMARKS
66559	MARTIN FLORINE	PA71870920	06/15/2017	\$137.50		06/15/2017		R&R-Invoice	Payroll Generated Invoice
00501	CRDU	PA71870202	06/15/2017	\$136.16		06/15/2017		R&R-Invoice	Payroll Generated Invoice
00523	AFLAC	PA71870212	06/15/2017	\$136.69		06/15/2017		R&R-Invoice	Payroll Generated Invoice
71944	TATUM VALERIE A	PA71870943	06/15/2017	\$134.46		06/15/2017		R&R-Invoice	Payroll Generated Invoice
60028	3P BENEFIT SOLUTIONS LLC	PA71870670	06/15/2017	\$133.50		06/15/2017		R&R-Invoice	Payroll Generated Invoice
00432	H D CATCHINGS AGENCY	PA71870109	06/15/2017	\$132.28		06/15/2017		R&R-Invoice	Payroll Generated Invoice
72016	ALLEN MIRANDA	PA71870944	06/15/2017	\$133.00		06/15/2017		R&R-Invoice	Payroll Generated Invoice
00501	CRDU	PA71870191	06/15/2017	\$131.55		06/15/2017		R&R-Invoice	Payroll Generated Invoice
71131	INTERNAL REVENUE SERVICE	PA71880136	06/16/2017	\$131.88		06/16/2017		R&R-Invoice	Payroll Generated Invoice
00418	COURTNEY & CAMP	PA71880015	06/16/2017	\$130.76		06/16/2017		R&R-Invoice	Payroll Generated Invoice
00415	LIFE OF ALABAMA	PA71870031	06/15/2017	\$129.18		06/15/2017		R&R-Invoice	Payroll Generated Invoice
00415	LIFE OF ALABAMA	PA71870044	06/15/2017	\$129.50		06/15/2017		R&R-Invoice	Payroll Generated Invoice
00928	ROBERTS CASSIE	PA71870611	06/15/2017	\$130.00		06/15/2017		R&R-Invoice	Payroll Generated Invoice
00877	MASE/CWA	PA71870587	06/15/2017	\$127.04		06/15/2017		R&R-Invoice	Payroll Generated Invoice
00951	JENKINS RUSSELL	PA71870629	06/15/2017	\$127.50		06/15/2017		R&R-Invoice	Payroll Generated Invoice
00523	AFLAC	PA71870235	06/15/2017	\$125.11		06/15/2017		R&R-Invoice	Payroll Generated Invoice
00597	LEVY CHATTE	PA71870371	06/15/2017	\$125.00		06/15/2017		R&R-Invoice	Payroll Generated Invoice
00760	PERSON PAULA	PA71870483	06/15/2017	\$125.00		06/15/2017		R&R-Invoice	Payroll Generated Invoice
00877	MASE/CWA	PA71870591	06/15/2017	\$124.26		06/15/2017		R&R-Invoice	Payroll Generated Invoice
71559	GADDIS THERESA	PA71870935	06/15/2017	\$125.00		06/15/2017		R&R-Invoice	Payroll Generated Invoice
00418	COURTNEY & CAMP	PA71640015	06/09/2017	\$123.39		06/09/2017		R&R-Invoice	Payroll Generated Invoice
00501	CRDU	PA71640034	06/09/2017	\$123.70		06/09/2017		R&R-Invoice	Payroll Generated Invoice
00501	CRDU	PA71640040	06/09/2017	\$123.46		06/09/2017		R&R-Invoice	Payroll Generated Invoice
00501	CRDU	PA71880034	06/16/2017	\$123.70		06/16/2017		R&R-Invoice	Payroll Generated Invoice
00501	CRDU	PA71880040	06/16/2017	\$123.46		06/16/2017		R&R-Invoice	Payroll Generated Invoice
00651	SIMPSON LAW FIRM PA	PA71870381	06/15/2017	\$123.78		06/15/2017		R&R-Invoice	Payroll Generated Invoice
00523	AFLAC	PA71870286	06/15/2017	\$120.16		06/15/2017		R&R-Invoice	Payroll Generated Invoice
00531	JRA PARKING	PA71870350	06/15/2017	\$120.12		06/15/2017		R&R-Invoice	Payroll Generated Invoice
60028	3P BENEFIT SOLUTIONS LLC	PA71870690	06/15/2017	\$120.00		06/15/2017		R&R-Invoice	Payroll Generated Invoice
00879	TREASURER OF VIRGINIA	PA71640107	06/09/2017	\$118.86		06/09/2017		R&R-Invoice	Payroll Generated Invoice
00879	TREASURER OF VIRGINIA	PA71880105	06/16/2017	\$118.86		06/16/2017		R&R-Invoice	Payroll Generated Invoice
00449	THRASH GARY	PA71870152	06/15/2017	\$116.75		06/15/2017		R&R-Invoice	Payroll Generated Invoice
65703	REPUBLIC FINANCE INC	PA71870743	06/15/2017	\$116.31		06/15/2017		R&R-Invoice	Payroll Generated Invoice
00962	KEYES DARLENE	PA71870631	06/15/2017	\$115.38		06/15/2017		R&R-Invoice	Payroll Generated Invoice
66394	COMPBENEFITS	PA71870802	06/15/2017	\$115.36		06/15/2017		R&R-Invoice	Payroll Generated Invoice
00501	CRDU	PA71640042	06/09/2017	\$114.01		06/09/2017		R&R-Invoice	Payroll Generated Invoice
00501	CRDU	PA71880042	06/16/2017	\$114.01		06/16/2017		R&R-Invoice	Payroll Generated Invoice
00501	CRDU	PA71870194	06/15/2017	\$112.50		06/15/2017		R&R-Invoice	Payroll Generated Invoice
00501	CRDU	PA71640033	06/09/2017	\$111.47		06/09/2017		R&R-Invoice	Payroll Generated Invoice
00877	MASE/CWA	PA71880033	06/16/2017	\$111.47		06/16/2017		R&R-Invoice	Payroll Generated Invoice
00877	MASE/CWA	PA71870592	06/15/2017	\$110.77		06/15/2017		R&R-Invoice	Payroll Generated Invoice
00501	CRDU	PA71880031	06/16/2017	\$110.77		06/16/2017		R&R-Invoice	Payroll Generated Invoice
00657	COLONIAL LIFE & ACCIDENT CO.	PA71870426	06/15/2017	\$110.87		06/15/2017		R&R-Invoice	Payroll Generated Invoice

VENDOR PAYMENTS / FOR CLAIM DOCKET - 06/27/2017
 REPORT TITLE - AMOUNTS (DESCENDING) ALL TYPES
 Invoice Payments Under \$500

AP757

VEN#	VENDOR-NAME	INVOICE	INV-DATE	AMOUNT	AUTHORIZATION	DUE-DATE	REF-NUMBER	PAYMENT-TYPE	REMARKS
65937	MEDELSON LAW FIRM	PA71640117	06/09/2017	\$110.63		06/09/2017		R&R-Invoice	Payroll Generated Invoice
00653	AMERICAN-AMICABLE LIFE INSURAN	PA71870400	06/15/2017	\$109.98		06/15/2017		R&R-Invoice	Payroll Generated Invoice
00432	H D CATCHINGS AGENCY	PA71870095	06/15/2017	\$106.79		06/15/2017		R&R-Invoice	Payroll Generated Invoice
00653	AMERICAN-AMICABLE LIFE INSURAN	PA71870394	06/15/2017	\$106.54		06/15/2017		R&R-Invoice	Payroll Generated Invoice
00432	H D CATCHINGS AGENCY	PA71870068	06/15/2017	\$105.06		06/15/2017		R&R-Invoice	Payroll Generated Invoice
00523	AFLAC	PA71870231	06/15/2017	\$105.05		06/15/2017		R&R-Invoice	Payroll Generated Invoice
00523	AFLAC	PA71870287	06/15/2017	\$105.93		06/15/2017		R&R-Invoice	Payroll Generated Invoice
00415	LIFE OF ALABAMA	PA71870015	06/15/2017	\$104.19		06/15/2017		R&R-Invoice	Payroll Generated Invoice
00657	COLONIAL LIFE & ACCIDENT CO.	PA71870428	06/15/2017	\$103.78		06/15/2017		R&R-Invoice	Payroll Generated Invoice
71131	INTERNAL REVENUE SERVICE	PA71640138	06/09/2017	\$102.11		06/09/2017		R&R-Invoice	Payroll Generated Invoice
00501	CRDU	PA71870199	06/15/2017	\$101.55		06/15/2017		R&R-Invoice	Payroll Generated Invoice
66394	COMPENEFITS	PA71870812	06/15/2017	\$101.08		06/15/2017		R&R-Invoice	Payroll Generated Invoice
00653	AMERICAN-AMICABLE LIFE INSURAN	PA71870409	06/15/2017	\$100.73		06/15/2017		R&R-Invoice	Payroll Generated Invoice
00432	H D CATCHINGS AGENCY	PA71870111	06/15/2017	\$99.33		06/15/2017		R&R-Invoice	Payroll Generated Invoice
00501	CRDU	PA71640041	06/09/2017	\$99.24		06/09/2017		R&R-Invoice	Payroll Generated Invoice
00501	CRDU	PA71880041	06/16/2017	\$99.24		06/16/2017		R&R-Invoice	Payroll Generated Invoice
00523	AFLAC	PA71870285	06/15/2017	\$99.49		06/15/2017		R&R-Invoice	Payroll Generated Invoice
00653	AMERICAN-AMICABLE LIFE INSURAN	PA71870397	06/15/2017	\$100.00		06/15/2017		R&R-Invoice	Payroll Generated Invoice
00415	LIFE OF ALABAMA	PA71870037	06/15/2017	\$98.42		06/15/2017		R&R-Invoice	Payroll Generated Invoice
60028	3P BENEFIT SOLUTIONS LLC	PA71870668	06/15/2017	\$96.15		06/15/2017		R&R-Invoice	Payroll Generated Invoice
60028	3P BENEFIT SOLUTIONS LLC	PA71870687	06/15/2017	\$96.15		06/15/2017		R&R-Invoice	Payroll Generated Invoice
60028	3P BENEFIT SOLUTIONS LLC	PA71870694	06/15/2017	\$96.15		06/15/2017		R&R-Invoice	Payroll Generated Invoice
60028	3P BENEFIT SOLUTIONS LLC	PA71870696	06/15/2017	\$96.15		06/15/2017		R&R-Invoice	Payroll Generated Invoice
60028	3P BENEFIT SOLUTIONS LLC	PA71870698	06/15/2017	\$96.15		06/15/2017		R&R-Invoice	Payroll Generated Invoice
00501	CRDU	PA71870205	06/15/2017	\$94.62		06/15/2017		R&R-Invoice	Payroll Generated Invoice
00877	MASE/CWA	PA71870599	06/15/2017	\$94.79		06/15/2017		R&R-Invoice	Payroll Generated Invoice
65572	UNUM PROVIDENT LIFE & ACCIDENT	PA71870727	06/15/2017	\$94.01		06/15/2017		R&R-Invoice	Payroll Generated Invoice
00523	AFLAC	PA71870234	06/15/2017	\$93.37		06/15/2017		R&R-Invoice	Payroll Generated Invoice
00651	SIMPSON LAW FIRM PA	PA71870379	06/15/2017	\$93.30		06/15/2017		R&R-Invoice	Payroll Generated Invoice
00765	AMERICAN HERITAGE LIFE INSURAN	PA71870502	06/15/2017	\$93.90		06/15/2017		R&R-Invoice	Payroll Generated Invoice
00523	AFLAC	PA71870290	06/15/2017	\$91.09		06/15/2017		R&R-Invoice	Payroll Generated Invoice
00657	COLONIAL LIFE & ACCIDENT CO.	PA71870432	06/15/2017	\$91.85		06/15/2017		R&R-Invoice	Payroll Generated Invoice
70838	THE WINN BROWN LAW FIRM PLLC	PA71870924	06/15/2017	\$91.21		06/15/2017		R&R-Invoice	Payroll Generated Invoice
00432	H D CATCHINGS AGENCY	PA71870063	06/15/2017	\$90.03		06/15/2017		R&R-Invoice	Payroll Generated Invoice
00523	AFLAC	PA71870237	06/15/2017	\$90.69		06/15/2017		R&R-Invoice	Payroll Generated Invoice
00523	AFLAC	PA71870289	06/15/2017	\$90.92		06/15/2017		R&R-Invoice	Payroll Generated Invoice
65572	UNUM PROVIDENT LIFE & ACCIDENT	PA71870720	06/15/2017	\$90.09		06/15/2017		R&R-Invoice	Payroll Generated Invoice
71786	U S A FUNDS	PA71870938	06/15/2017	\$90.57		06/15/2017		R&R-Invoice	Payroll Generated Invoice
00523	AFLAC	PA71870246	06/15/2017	\$89.10		06/15/2017		R&R-Invoice	Payroll Generated Invoice
00523	AFLAC	PA71870291	06/15/2017	\$89.02		06/15/2017		R&R-Invoice	Payroll Generated Invoice
66136	STATE DISBURSEMENT UNIT	PA71870749	06/15/2017	\$88.25		06/15/2017		R&R-Invoice	Payroll Generated Invoice
00657	COLONIAL LIFE & ACCIDENT CO.	PA71870431	06/15/2017	\$87.50		06/15/2017		R&R-Invoice	Payroll Generated Invoice
65937	MEDELSON LAW FIRM	PA71880115	06/16/2017	\$87.65		06/16/2017		R&R-Invoice	Payroll Generated Invoice

AP757
 VENDOR PAYMENTS / FOR CLAIM DOCKET - 06/27/2017
 REPORT TITLE - AMOUNTS (DESCENDING) ALL TYPES
 Invoice Payments Under \$500

VEN#	VENDOR-NAME	INVOICE	INV-DATE	AMOUNT	AUTHORIZATION	DUE-DATE	REF-NUMBER	PAYMENT-TYPE	REMARKS
71815	INTERNAL REVENUE SERVICE	PA71870940	06/15/2017	\$88.00		06/15/2017		R&R-Invoice	Payroll Generated Invoice
00530	AMERICAN GENERAL LIFE	PA71870323	06/15/2017	\$86.68		06/15/2017		R&R-Invoice	Payroll Generated Invoice
65572	UNUM PROVIDENT LIFE & ACCIDENT	PA71870715	06/15/2017	\$86.87		06/15/2017		R&R-Invoice	Payroll Generated Invoice
00415	LIFE OF ALABAMA	PA71870032	06/15/2017	\$85.94		06/15/2017		R&R-Invoice	Payroll Generated Invoice
00501	CRDU	PA71870180	06/15/2017	\$85.39		06/15/2017		R&R-Invoice	Payroll Generated Invoice
00877	MASE/CWA	PA71870581	06/15/2017	\$85.79		06/15/2017		R&R-Invoice	Payroll Generated Invoice
00418	COURTNEY & CAMP	PA71640014	06/09/2017	\$83.03		06/09/2017		R&R-Invoice	Payroll Generated Invoice
00501	CRDU	PA71870173	06/15/2017	\$83.08		06/15/2017		R&R-Invoice	Payroll Generated Invoice
00512	MS EMPLOYMENT SECURITY	PA71640044	06/09/2017	\$83.67		06/09/2017		R&R-Invoice	Payroll Generated Invoice
00418	COURTNEY & CAMP	PA71888014	06/16/2017	\$82.33		06/16/2017		R&R-Invoice	Payroll Generated Invoice
00523	AFLAC	PA71870208	06/15/2017	\$82.26		06/15/2017		R&R-Invoice	Payroll Generated Invoice
60028	3P BENEFIT SOLUTIONS LLC	PA71870699	06/15/2017	\$83.00		06/15/2017		R&R-Invoice	Payroll Generated Invoice
71566	A-1 CHECK CASHING INC	PA71640139	06/09/2017	\$82.34		06/09/2017		R&R-Invoice	Payroll Generated Invoice
71566	A-1 CHECK CASHING INC	PA718880137	06/16/2017	\$82.34		06/16/2017		R&R-Invoice	Payroll Generated Invoice
00448	PENNSYLVANIA LIFE INSURANCE CO	PA71870142	06/15/2017	\$81.68		06/15/2017		R&R-Invoice	Payroll Generated Invoice
00877	MASE/CWA	PA71870545	06/15/2017	\$81.73		06/15/2017		R&R-Invoice	Payroll Generated Invoice
00432	H D CATCHINGS AGENCY	PA71870050	06/15/2017	\$80.61		06/15/2017		R&R-Invoice	Payroll Generated Invoice
00432	H D CATCHINGS AGENCY	PA71870110	06/15/2017	\$80.00		06/15/2017		R&R-Invoice	Payroll Generated Invoice
00415	LIFE OF ALABAMA	PA71870016	06/15/2017	\$78.78		06/15/2017		R&R-Invoice	Payroll Generated Invoice
00877	MASE/CWA	PA71870590	06/15/2017	\$78.41		06/15/2017		R&R-Invoice	Payroll Generated Invoice
64220	TX CHILD SUPPORT SDU	PA71640112	06/09/2017	\$78.92		06/09/2017		R&R-Invoice	Payroll Generated Invoice
64220	TX CHILD SUPPORT SDU	PA71880110	06/16/2017	\$78.92		06/16/2017		R&R-Invoice	Payroll Generated Invoice
00523	AFLAC	PA71870242	06/15/2017	\$77.16		06/15/2017		R&R-Invoice	Payroll Generated Invoice
00651	SIMPSON LAW FIRM PA	PA71870346	06/15/2017	\$77.85		06/15/2017		R&R-Invoice	Payroll Generated Invoice
00877	MASE/CWA	PA71870595	06/15/2017	\$77.26		06/15/2017		R&R-Invoice	Payroll Generated Invoice
60028	3P BENEFIT SOLUTIONS LLC	PA71870681	06/15/2017	\$78.00		06/15/2017		R&R-Invoice	Payroll Generated Invoice
60028	3P BENEFIT SOLUTIONS LLC	PA71870704	06/15/2017	\$77.23		06/15/2017		R&R-Invoice	Payroll Generated Invoice
00432	H D CATCHINGS AGENCY	PA71870053	06/15/2017	\$76.85		06/15/2017		R&R-Invoice	Payroll Generated Invoice
00442	HAROLD J BARKLEY JR, TRUSTEE	PA71870119	06/15/2017	\$77.00		06/15/2017		R&R-Invoice	Payroll Generated Invoice
00523	AFLAC	PA71870221	06/15/2017	\$76.68		06/15/2017		R&R-Invoice	Payroll Generated Invoice
00653	AMERICAN-AMICABLE LIFE INSURAN	PA71870399	06/15/2017	\$76.84		06/15/2017		R&R-Invoice	Payroll Generated Invoice
01026	TOWER LOAN OF PEARL	PA71640111	06/09/2017	\$76.88		06/09/2017		R&R-Invoice	Payroll Generated Invoice
01026	TOWER LOAN OF PEARL	PA71880109	06/16/2017	\$76.88		06/16/2017		R&R-Invoice	Payroll Generated Invoice
60028	3P BENEFIT SOLUTIONS LLC	PA71870678	06/15/2017	\$77.00		06/15/2017		R&R-Invoice	Payroll Generated Invoice
60028	3P BENEFIT SOLUTIONS LLC	PA71870679	06/15/2017	\$76.96		06/15/2017		R&R-Invoice	Payroll Generated Invoice
60028	3P BENEFIT SOLUTIONS LLC	PA71870680	06/15/2017	\$77.00		06/15/2017		R&R-Invoice	Payroll Generated Invoice
60028	3P BENEFIT SOLUTIONS LLC	PA71870702	06/15/2017	\$76.92		06/15/2017		R&R-Invoice	Payroll Generated Invoice
00909	CLERK UNITED STATES DISTRICT	PA71870607	06/15/2017	\$75.00		06/15/2017		R&R-Invoice	Payroll Generated Invoice
66394	COMPENEFITS	PA71870814	06/15/2017	\$74.27		06/15/2017		R&R-Invoice	Payroll Generated Invoice
00432	H D CATCHINGS AGENCY	PA71870061	06/15/2017	\$73.28		06/15/2017		R&R-Invoice	Payroll Generated Invoice
00449	THRASH GARY	PA71640028	06/09/2017	\$73.42		06/09/2017		R&R-Invoice	Payroll Generated Invoice
00449	THRASH GARY	PA71880028	06/16/2017	\$73.24		06/16/2017		R&R-Invoice	Payroll Generated Invoice
00531	JRA PARKING	PA71870335	06/15/2017	\$73.92		06/15/2017		R&R-Invoice	Payroll Generated Invoice

AP757

VENDOR PAYMENTS / FOR CLAIM DOCKET - 06/27/2017
 REPORT TITLE - AMOUNTS (DESCENDING) ALL TYPES
 Invoice Payments Under \$500

VEN#	VENDOR-NAME	INVOICE	INV-DATE	AMOUNT	AUTHORIZATION	DUE-DATE	REF-NUMBER	PAYMENT-TYPE	REMARKS
00531	JRA PARKING	PAY1870343	06/15/2017	\$73.92		06/15/2017		R&R-Invoice	Payroll Generated Invoice
00531	JRA PARKING	PAY1870349	06/15/2017	\$73.92		06/15/2017		R&R-Invoice	Payroll Generated Invoice
00746	BARBOUR IV JEPHTHA F	PAY1880075	06/16/2017	\$73.01		06/16/2017		R&R-Invoice	Payroll Generated Invoice
00877	MASE/CWA	PAY1870579	06/15/2017	\$73.10		06/15/2017		R&R-Invoice	Payroll Generated Invoice
00501	CRDU	PAY1870186	06/15/2017	\$71.54		06/15/2017		R&R-Invoice	Payroll Generated Invoice
60028	3P BENEFIT SOLUTIONS LLC	PAY1870672	06/15/2017	\$72.00		06/15/2017		R&R-Invoice	Payroll Generated Invoice
00415	LIFE OF ALABAMA	PAY1870017	06/15/2017	\$70.89		06/15/2017		R&R-Invoice	Payroll Generated Invoice
00877	MASE/CWA	PAY1870560	06/15/2017	\$70.66		06/15/2017		R&R-Invoice	Payroll Generated Invoice
00523	AFLAC	PAY1870241	06/15/2017	\$69.31		06/15/2017		R&R-Invoice	Payroll Generated Invoice
00657	COLONIAL LIFE & ACCIDENT CO.	PAY1870421	06/15/2017	\$69.57		06/15/2017		R&R-Invoice	Payroll Generated Invoice
00765	AMERICAN HERITAGE LIFE INSURAN	PAY1870524	06/15/2017	\$69.46		06/15/2017		R&R-Invoice	Payroll Generated Invoice
60028	3P BENEFIT SOLUTIONS LLC	PAY1870671	06/15/2017	\$70.00		06/15/2017		R&R-Invoice	Payroll Generated Invoice
65166	CROWLEY CYNTHIA RENEE BINGHAM	PAY1870711	06/15/2017	\$70.00		06/15/2017		R&R-Invoice	Payroll Generated Invoice
66394	COMPBENEFITS	PAY1870820	06/15/2017	\$68.59		06/15/2017		R&R-Invoice	Payroll Generated Invoice
00415	LIFE OF ALABAMA	PAY1870014	06/15/2017	\$67.48		06/15/2017		R&R-Invoice	Payroll Generated Invoice
00432	H D CATCHINGS AGENCY	PAY1870085	06/15/2017	\$67.12		06/15/2017		R&R-Invoice	Payroll Generated Invoice
00523	AFLAC	PAY1870209	06/15/2017	\$66.70		06/15/2017		R&R-Invoice	Payroll Generated Invoice
00523	AFLAC	PAY1870229	06/15/2017	\$66.78		06/15/2017		R&R-Invoice	Payroll Generated Invoice
00523	AFLAC	PAY1870296	06/15/2017	\$66.60		06/15/2017		R&R-Invoice	Payroll Generated Invoice
00530	AMERICAN GENERAL LIFE	PAY1870321	06/15/2017	\$66.32		06/15/2017		R&R-Invoice	Payroll Generated Invoice
00726	JAMES L HENLEY	PAY1640076	06/09/2017	\$66.50		06/09/2017		R&R-Invoice	Payroll Generated Invoice
00726	JAMES L HENLEY	PAY1880074	06/16/2017	\$66.50		06/16/2017		R&R-Invoice	Payroll Generated Invoice
00432	H D CATCHINGS AGENCY	PAY1870084	06/15/2017	\$65.17		06/15/2017		R&R-Invoice	Payroll Generated Invoice
00501	CRDU	PAY1640037	06/09/2017	\$65.08		06/09/2017		R&R-Invoice	Payroll Generated Invoice
00501	CRDU	PAY1880037	06/16/2017	\$65.08		06/16/2017		R&R-Invoice	Payroll Generated Invoice
00651	SIMPSON LAW FIRM PA	PAY1640061	06/09/2017	\$65.02		06/09/2017		R&R-Invoice	Payroll Generated Invoice
00531	JRA PARKING	PAY1870330	06/15/2017	\$64.68		06/15/2017		R&R-Invoice	Payroll Generated Invoice
00523	AFLAC	PAY1870301	06/15/2017	\$63.49		06/15/2017		R&R-Invoice	Payroll Generated Invoice
60028	3P BENEFIT SOLUTIONS LLC	PAY1870677	06/15/2017	\$63.30		06/15/2017		R&R-Invoice	Payroll Generated Invoice
65572	UNUM PROVIDENT LIFE & ACCIDENT	PAY1870737	06/15/2017	\$62.58		06/15/2017		R&R-Invoice	Payroll Generated Invoice
65937	MEDELSON LAW FIRM	PAY1870746	06/15/2017	\$61.48		06/15/2017		R&R-Invoice	Payroll Generated Invoice
66394	COMPBENEFITS	PAY1870782	06/15/2017	\$61.37		06/15/2017		R&R-Invoice	Payroll Generated Invoice
00523	AFLAC	PAY1870271	06/15/2017	\$59.02		06/15/2017		R&R-Invoice	Payroll Generated Invoice
00657	COLONIAL LIFE & ACCIDENT CO.	PAY1870419	06/15/2017	\$59.33		06/15/2017		R&R-Invoice	Payroll Generated Invoice
00765	AMERICAN HERITAGE LIFE INSURAN	PAY1870514	06/15/2017	\$58.78		06/15/2017		R&R-Invoice	Payroll Generated Invoice
00657	COLONIAL LIFE & ACCIDENT CO.	PAY1870447	06/15/2017	\$57.08		06/15/2017		R&R-Invoice	Payroll Generated Invoice
00848	JACKSON FIREFIGHTERS ASSOC	PAY1870535	06/15/2017	\$57.70		06/15/2017		R&R-Invoice	Payroll Generated Invoice
00848	JACKSON FIREFIGHTERS ASSOC	PAY1870538	06/15/2017	\$57.70		06/15/2017		R&R-Invoice	Payroll Generated Invoice
00877	MASE/CWA	PAY1870552	06/15/2017	\$57.16		06/15/2017		R&R-Invoice	Payroll Generated Invoice
60028	3P BENEFIT SOLUTIONS LLC	PAY1870706	06/15/2017	\$57.69		06/15/2017		R&R-Invoice	Payroll Generated Invoice
66394	COMPBENEFITS	PAY1870821	06/15/2017	\$57.68		06/15/2017		R&R-Invoice	Payroll Generated Invoice
00432	H D CATCHINGS AGENCY	PAY1870080	06/15/2017	\$56.82		06/15/2017		R&R-Invoice	Payroll Generated Invoice
00523	AFLAC	PAY1870240	06/15/2017	\$56.56		06/15/2017		R&R-Invoice	Payroll Generated Invoice

AP757
 REPORT TITLE - AMOUNTS (DESCENDING) ALL TYPES
 Invoice Payments Under \$500

VEN#	VENDOR-NAME	INVOICE	INV-DATE	AMOUNT	AUTHORIZATION	DUE-DATE	REF-NUMBER	PAYMENT-TYPE	REMARKS
00653	AMERICAN-AMICABLE LIFE INSURAN	PA71870411	06/15/2017	\$57.00		06/15/2017		R&R-Invoice	Payroll Generated Invoice
00523	AFLAC	PA71870283	06/15/2017	\$55.08		06/15/2017		R&R-Invoice	Payroll Generated Invoice
00529	POLICE HOSPITAL FUND	PA71870316	06/15/2017	\$55.44		06/15/2017		R&R-Invoice	Payroll Generated Invoice
65572	UNUM PROVIDENT LIFE & ACCIDENT	PA71870726	06/15/2017	\$55.94		06/15/2017		R&R-Invoice	Payroll Generated Invoice
00442	HAROLD J BARKLEY JR, TRUSTEE	PA71870118	06/15/2017	\$55.00		06/15/2017		R&R-Invoice	Payroll Generated Invoice
00448	PENNSYLVANIA LIFE INSURANCE CO	PA71870139	06/15/2017	\$54.38		06/15/2017		R&R-Invoice	Payroll Generated Invoice
00523	AFLAC	PA71870260	06/15/2017	\$54.78		06/15/2017		R&R-Invoice	Payroll Generated Invoice
00415	LIFE OF ALABAMA	PA718702025	06/15/2017	\$53.64		06/15/2017		R&R-Invoice	Payroll Generated Invoice
00432	H D CATCHINGS AGENCY	PA71870108	06/15/2017	\$53.68		06/15/2017		R&R-Invoice	Payroll Generated Invoice
00523	AFLAC	PA71870213	06/15/2017	\$53.14		06/15/2017		R&R-Invoice	Payroll Generated Invoice
00765	AMERICAN HERITAGE LIFE INSURAN	PA71870504	06/15/2017	\$53.29		06/15/2017		R&R-Invoice	Payroll Generated Invoice
00877	MASE/CWA	PA71640092	06/09/2017	\$53.76		06/09/2017		R&R-Invoice	Payroll Generated Invoice
00877	MASE/CWA	PA71880090	06/16/2017	\$53.76		06/16/2017		R&R-Invoice	Payroll Generated Invoice
00432	H D CATCHINGS AGENCY	PA71870055	06/15/2017	\$52.03		06/15/2017		R&R-Invoice	Payroll Generated Invoice
00501	CRDU	PA71870178	06/15/2017	\$52.50		06/15/2017		R&R-Invoice	Payroll Generated Invoice
00415	LIFE OF ALABAMA	PA71870011	06/15/2017	\$51.67		06/15/2017		R&R-Invoice	Payroll Generated Invoice
00415	LIFE OF ALABAMA	PA71870026	06/15/2017	\$51.63		06/15/2017		R&R-Invoice	Payroll Generated Invoice
00432	H D CATCHINGS AGENCY	PA71870097	06/15/2017	\$51.58		06/15/2017		R&R-Invoice	Payroll Generated Invoice
00523	AFLAC	PA71870218	06/15/2017	\$51.28		06/15/2017		R&R-Invoice	Payroll Generated Invoice
00877	MASE/CWA	PA71870558	06/15/2017	\$51.94		06/15/2017		R&R-Invoice	Payroll Generated Invoice
00415	LIFE OF ALABAMA	PA71870010	06/15/2017	\$50.55		06/15/2017		R&R-Invoice	Payroll Generated Invoice
00523	AFLAC	PA71870227	06/15/2017	\$50.30		06/15/2017		R&R-Invoice	Payroll Generated Invoice
00877	MASE/CWA	PA71870573	06/15/2017	\$50.38		06/15/2017		R&R-Invoice	Payroll Generated Invoice
66394	COMPBENEFITS	PA71870783	06/15/2017	\$50.47		06/15/2017		R&R-Invoice	Payroll Generated Invoice
66394	COMPBENEFITS	PA71870813	06/15/2017	\$50.47		06/15/2017		R&R-Invoice	Payroll Generated Invoice
70710	JRS	PA71870922	06/15/2017	\$50.26		06/15/2017		R&R-Invoice	Payroll Generated Invoice
00453	INTERNAL REVENUE SERVICE	PA71870158	06/15/2017	\$50.00		06/15/2017		R&R-Invoice	Payroll Generated Invoice
00501	CRDU	PA71640038	06/09/2017	\$49.62		06/09/2017		R&R-Invoice	Payroll Generated Invoice
00501	CRDU	PA71880038	06/16/2017	\$49.62		06/16/2017		R&R-Invoice	Payroll Generated Invoice
00523	AFLAC	PA71870277	06/15/2017	\$49.51		06/15/2017		R&R-Invoice	Payroll Generated Invoice
00746	BARBOUR IV JEPHHA F	PA71870477	06/15/2017	\$50.00		06/15/2017		R&R-Invoice	Payroll Generated Invoice
00906	LAFAYETTE COUNTY CIRCUIT COURT	PA71870605	06/15/2017	\$50.00		06/15/2017		R&R-Invoice	Payroll Generated Invoice
60028	3P BENEFIT SOLUTIONS LLC	PA71870695	06/15/2017	\$50.00		06/15/2017		R&R-Invoice	Payroll Generated Invoice
00657	COLONIAL LIFE & ACCIDENT CO.	PA71870444	06/15/2017	\$48.69		06/15/2017		R&R-Invoice	Payroll Generated Invoice
00746	BARBOUR IV JEPHHA F	PA71640077	06/09/2017	\$48.79		06/09/2017		R&R-Invoice	Payroll Generated Invoice
06867	GENERAL FUND	PA71870653	06/15/2017	\$48.44		06/15/2017		R&R-Invoice	Payroll Generated Invoice
65572	UNUM PROVIDENT LIFE & ACCIDENT	PA71870723	06/15/2017	\$48.62		06/15/2017		R&R-Invoice	Payroll Generated Invoice
00415	LIFE OF ALABAMA	PA71640011	06/09/2017	\$47.30		06/09/2017		R&R-Invoice	Payroll Generated Invoice
00415	LIFE OF ALABAMA	PA71880011	06/16/2017	\$47.30		06/16/2017		R&R-Invoice	Payroll Generated Invoice
00432	H D CATCHINGS AGENCY	PA71870052	06/15/2017	\$47.35		06/15/2017		R&R-Invoice	Payroll Generated Invoice
00432	H D CATCHINGS AGENCY	PA71870064	06/15/2017	\$47.01		06/15/2017		R&R-Invoice	Payroll Generated Invoice
00432	H D CATCHINGS AGENCY	PA71870082	06/15/2017	\$47.11		06/15/2017		R&R-Invoice	Payroll Generated Invoice

AP757

VENDOR PAYMENTS / FOR CLAIM DOCKET - 06/27/2017
 REPORT TITLE - AMOUNTS (DESCENDING) ALL TYPES
 Invoice Payments Under \$500

VEN#	VENDOR-NAME	INVOICE	INV-DATE	AMOUNT	AUTHORIZATION	DUE-DATE	REF-NUMBER	PAYMENT-TYPE	REMARKS
00501	CRDU	PA71640031	06/09/2017	\$47.30		06/09/2017		R&R-Invoice	Payroll Generated Invoice
00523	AFLAC	PA71870210	06/15/2017	\$47.70		06/15/2017		R&R-Invoice	Payroll Generated Invoice
00523	AFLAC	PA71870230	06/15/2017	\$47.63		06/15/2017		R&R-Invoice	Payroll Generated Invoice
00653	AMERICAN-AMICABLE LIFE INSURAN	PA71640063	06/09/2017	\$47.12		06/09/2017		R&R-Invoice	Payroll Generated Invoice
00653	AMERICAN-AMICABLE LIFE INSURAN	PA71880062	06/16/2017	\$47.12		06/16/2017		R&R-Invoice	Payroll Generated Invoice
00794	NATIONAL PAYMENT CENTER	PA71640088	06/09/2017	\$47.04		06/09/2017		R&R-Invoice	Payroll Generated Invoice
00794	NATIONAL PAYMENT CENTER	PA71880086	06/16/2017	\$47.04		06/16/2017		R&R-Invoice	Payroll Generated Invoice
00877	MASE/CWA	PA71870594	06/15/2017	\$47.71		06/15/2017		R&R-Invoice	Payroll Generated Invoice
00415	LIFE OF ALABAMA	PA71870007	06/15/2017	\$46.77		06/15/2017		R&R-Invoice	Payroll Generated Invoice
00415	LIFE OF ALABAMA	PA71870027	06/15/2017	\$46.89		06/15/2017		R&R-Invoice	Payroll Generated Invoice
00432	H D CATCHINGS AGENCY	PA71870058	06/15/2017	\$46.93		06/15/2017		R&R-Invoice	Payroll Generated Invoice
00501	CRDU	PA71640039	06/09/2017	\$46.62		06/09/2017		R&R-Invoice	Payroll Generated Invoice
00501	CRDU	PA71880039	06/16/2017	\$46.62		06/16/2017		R&R-Invoice	Payroll Generated Invoice
00523	AFLAC	PA71870266	06/15/2017	\$46.71		06/15/2017		R&R-Invoice	Payroll Generated Invoice
60028	3P BENEFIT SOLUTIONS LLC	PA71870663	06/15/2017	\$46.15		06/15/2017		R&R-Invoice	Payroll Generated Invoice
65572	UNUM PROVIDENT LIFE & ACCIDENT	PA71870716	06/15/2017	\$46.30		06/15/2017		R&R-Invoice	Payroll Generated Invoice
00415	LIFE OF ALABAMA	PA71870038	06/15/2017	\$45.08		06/15/2017		R&R-Invoice	Payroll Generated Invoice
00432	H D CATCHINGS AGENCY	PA71870090	06/15/2017	\$45.06		06/15/2017		R&R-Invoice	Payroll Generated Invoice
00523	AFLAC	PA71870223	06/15/2017	\$45.36		06/15/2017		R&R-Invoice	Payroll Generated Invoice
00765	AMERICAN HERITAGE LIFE INSURAN	PA71870500	06/15/2017	\$45.86		06/15/2017		R&R-Invoice	Payroll Generated Invoice
00877	MASE/CWA	PA71640101	06/09/2017	\$45.71		06/09/2017		R&R-Invoice	Payroll Generated Invoice
00877	MASE/CWA	PA71880099	06/16/2017	\$45.71		06/16/2017		R&R-Invoice	Payroll Generated Invoice
00432	H D CATCHINGS AGENCY	PA71870074	06/15/2017	\$44.92		06/15/2017		R&R-Invoice	Payroll Generated Invoice
00432	H D CATCHINGS AGENCY	PA71870077	06/15/2017	\$44.66		06/15/2017		R&R-Invoice	Payroll Generated Invoice
00432	H D CATCHINGS AGENCY	PA71870087	06/15/2017	\$44.44		06/15/2017		R&R-Invoice	Payroll Generated Invoice
00523	AFLAC	PA71870303	06/15/2017	\$44.34		06/15/2017		R&R-Invoice	Payroll Generated Invoice
00415	LIFE OF ALABAMA	PA71870030	06/15/2017	\$43.22		06/15/2017		R&R-Invoice	Payroll Generated Invoice
00432	H D CATCHINGS AGENCY	PA71870112	06/15/2017	\$43.04		06/15/2017		R&R-Invoice	Payroll Generated Invoice
00523	AFLAC	PA71870253	06/15/2017	\$43.50		06/15/2017		R&R-Invoice	Payroll Generated Invoice
00530	AMERICAN GENERAL LIFE	PA71870320	06/15/2017	\$43.11		06/15/2017		R&R-Invoice	Payroll Generated Invoice
65572	UNUM PROVIDENT LIFE & ACCIDENT	PA71870717	06/15/2017	\$43.12		06/15/2017		R&R-Invoice	Payroll Generated Invoice
66394	COMPBENEFITS	PA71870882	06/15/2017	\$43.32		06/15/2017		R&R-Invoice	Payroll Generated Invoice
70874	SOUTHERN STATES POLICE BENEVL	PA71870926	06/15/2017	\$43.40		06/15/2017		R&R-Invoice	Payroll Generated Invoice
00432	H D CATCHINGS AGENCY	PA71870093	06/15/2017	\$42.58		06/15/2017		R&R-Invoice	Payroll Generated Invoice
00877	MASE/CWA	PA71870596	06/15/2017	\$42.82		06/15/2017		R&R-Invoice	Payroll Generated Invoice
00501	CRDU	PA71640043	06/09/2017	\$42.00		06/09/2017		R&R-Invoice	Payroll Generated Invoice
00501	CRDU	PA71880043	06/16/2017	\$42.00		06/16/2017		R&R-Invoice	Payroll Generated Invoice
00523	AFLAC	PA71870217	06/15/2017	\$41.63		06/15/2017		R&R-Invoice	Payroll Generated Invoice
00523	AFLAC	PA71870284	06/15/2017	\$41.40		06/15/2017		R&R-Invoice	Payroll Generated Invoice
00529	POLICE HOSPITAL FUND	PA71870309	06/15/2017	\$41.58		06/15/2017		R&R-Invoice	Payroll Generated Invoice
06867	GENERAL FUND	PA71870646	06/15/2017	\$41.52		06/15/2017		R&R-Invoice	Payroll Generated Invoice
06867	GENERAL FUND	PA71870651	06/15/2017	\$41.52		06/15/2017		R&R-Invoice	Payroll Generated Invoice
65572	UNUM PROVIDENT LIFE & ACCIDENT	PA71870740	06/15/2017	\$41.34		06/15/2017		R&R-Invoice	Payroll Generated Invoice

AP757
 VENDOR PAYMENTS / FOR CLAIM DOCKET - 06/27/2017
 REPORT TITLE - AMOUNTS (DESCENDING) ALL TYPES
 Invoice Payments Under \$500

VEN#	VENDOR-NAME	INVOICE	INV-DATE	AMOUNT	AUTHORIZATION	DUE-DATE	REF-NUMBER	PAYMENT-TYPE	REMARKS
00432	H D CATCHINGS AGENCY	PA71870076	06/15/2017	\$40.45		06/15/2017		R&R-Invoice	Payroll Generated Invoice
00432	H D CATCHINGS AGENCY	PA71870103	06/15/2017	\$40.77		06/15/2017		R&R-Invoice	Payroll Generated Invoice
00653	AMERICAN-AMICABLE LIFE INSURAN	PA71870383	06/15/2017	\$40.54		06/15/2017		R&R-Invoice	Payroll Generated Invoice
00877	MASE/CWA	PA71870600	06/15/2017	\$40.55		06/15/2017		R&R-Invoice	Payroll Generated Invoice
00415	LIFE OF ALABAMA	PA71640009	06/09/2017	\$39.60		06/09/2017		R&R-Invoice	Payroll Generated Invoice
00415	LIFE OF ALABAMA	PA71880009	06/16/2017	\$39.60		06/16/2017		R&R-Invoice	Payroll Generated Invoice
00726	JAMES L HENLEY	PA71640075	06/09/2017	\$40.00		06/09/2017		R&R-Invoice	Payroll Generated Invoice
00765	AMERICAN HERITAGE LIFE INSURAN	PA71870521	06/15/2017	\$39.28		06/15/2017		R&R-Invoice	Payroll Generated Invoice
00873	PIONEER CREDIT COMPANY	PA71870542	06/15/2017	\$39.95		06/15/2017		R&R-Invoice	Payroll Generated Invoice
60028	3P BENEFIT SOLUTIONS LLC	PA71870662	06/15/2017	\$40.00		06/15/2017		R&R-Invoice	Payroll Generated Invoice
60028	3P BENEFIT SOLUTIONS LLC	PA71870669	06/15/2017	\$40.00		06/15/2017		R&R-Invoice	Payroll Generated Invoice
60028	3P BENEFIT SOLUTIONS LLC	PA71870674	06/15/2017	\$40.00		06/15/2017		R&R-Invoice	Payroll Generated Invoice
65572	UNUM PROVIDENT LIFE & ACCIDENT	PA71870718	06/15/2017	\$39.52		06/15/2017		R&R-Invoice	Payroll Generated Invoice
00501	CRDU	PA71640036	06/09/2017	\$38.31		06/09/2017		R&R-Invoice	Payroll Generated Invoice
00501	CRDU	PA71880036	06/16/2017	\$38.31		06/16/2017		R&R-Invoice	Payroll Generated Invoice
00523	AFLAC	PA71870272	06/15/2017	\$38.33		06/15/2017		R&R-Invoice	Payroll Generated Invoice
00765	AMERICAN HERITAGE LIFE INSURAN	PA71870503	06/15/2017	\$38.21		06/15/2017		R&R-Invoice	Payroll Generated Invoice
00765	AMERICAN HERITAGE LIFE INSURAN	PA71870526	06/15/2017	\$38.13		06/15/2017		R&R-Invoice	Payroll Generated Invoice
60028	3P BENEFIT SOLUTIONS LLC	PA71870686	06/15/2017	\$38.46		06/15/2017		R&R-Invoice	Payroll Generated Invoice
60028	3P BENEFIT SOLUTIONS LLC	PA71870707	06/15/2017	\$38.46		06/15/2017		R&R-Invoice	Payroll Generated Invoice
65572	UNUM PROVIDENT LIFE & ACCIDENT	PA71870728	06/15/2017	\$38.60		06/15/2017		R&R-Invoice	Payroll Generated Invoice
00523	AFLAC	PA71870219	06/15/2017	\$37.80		06/15/2017		R&R-Invoice	Payroll Generated Invoice
00765	AMERICAN HERITAGE LIFE INSURAN	PA71870495	06/15/2017	\$37.73		06/15/2017		R&R-Invoice	Payroll Generated Invoice
65572	UNUM PROVIDENT LIFE & ACCIDENT	PA71870721	06/15/2017	\$37.26		06/15/2017		R&R-Invoice	Payroll Generated Invoice
00432	H D CATCHINGS AGENCY	PA71640024	06/09/2017	\$36.07		06/09/2017		R&R-Invoice	Payroll Generated Invoice
00432	H D CATCHINGS AGENCY	PA71880024	06/16/2017	\$36.07		06/16/2017		R&R-Invoice	Payroll Generated Invoice
00523	AFLAC	PA71870269	06/15/2017	\$36.72		06/15/2017		R&R-Invoice	Payroll Generated Invoice
00523	AFLAC	PA71870270	06/15/2017	\$36.60		06/15/2017		R&R-Invoice	Payroll Generated Invoice
00523	AFLAC	PA71870295	06/15/2017	\$36.30		06/15/2017		R&R-Invoice	Payroll Generated Invoice
00531	JRA PARKING	PA71870333	06/15/2017	\$36.96		06/15/2017		R&R-Invoice	Payroll Generated Invoice
00531	JRA PARKING	PA71870344	06/15/2017	\$36.96		06/15/2017		R&R-Invoice	Payroll Generated Invoice
00531	JRA PARKING	PA71870346	06/15/2017	\$36.96		06/15/2017		R&R-Invoice	Payroll Generated Invoice
00531	JRA PARKING	PA71870354	06/15/2017	\$36.96		06/15/2017		R&R-Invoice	Payroll Generated Invoice
00531	JRA PARKING	PA71870356	06/15/2017	\$36.96		06/15/2017		R&R-Invoice	Payroll Generated Invoice
00653	AMERICAN-AMICABLE LIFE INSURAN	PA71870405	06/15/2017	\$36.44		06/15/2017		R&R-Invoice	Payroll Generated Invoice
00764	OCCIDENTAL LIFE INSURANCE CO	PA71870491	06/15/2017	\$36.92		06/15/2017		R&R-Invoice	Payroll Generated Invoice
65572	UNUM PROVIDENT LIFE & ACCIDENT	PA71870738	06/15/2017	\$36.72		06/15/2017		R&R-Invoice	Payroll Generated Invoice
66394	COMPBENEFITS	PA71870759	06/15/2017	\$36.10		06/15/2017		R&R-Invoice	Payroll Generated Invoice
00415	LIFE OF ALABAMA	PA71870036	06/15/2017	\$35.36		06/15/2017		R&R-Invoice	Payroll Generated Invoice
00448	PENNSYLVANIA LIFE INSURANCE CO	PA71870134	06/15/2017	\$35.64		06/15/2017		R&R-Invoice	Payroll Generated Invoice
00523	AFLAC	PA71640056	06/09/2017	\$35.76		06/09/2017		R&R-Invoice	Payroll Generated Invoice
00523	AFLAC	PA71870300	06/15/2017	\$35.70		06/15/2017		R&R-Invoice	Payroll Generated Invoice
00523	AFLAC	PA71880055	06/16/2017	\$35.76		06/16/2017		R&R-Invoice	Payroll Generated Invoice

AP757

VENDOR PAYMENTS / FOR CLAIM DOCKET - 06/27/2017
 REPORT TITLE - AMOUNTS (DESCENDING) ALL TYPES
 Invoice Payments Under \$500

VEN#	VENDOR-NAME	INVOICE	INV-DATE	AMOUNT	AUTHORIZATION	DUE-DATE	REF-NUMBER	PAYMENT-TYPE	REMARKS
00657	COLONIAL LIFE & ACCIDENT CO.	PA71870413	06/15/2017	\$35.61		06/15/2017		R&R-Invoice	Payroll Generated Invoice
00746	BARBOUR IV JEPHTHA F	PA71870478	06/15/2017	\$35.06		06/15/2017		R&R-Invoice	Payroll Generated Invoice
00877	MASE/CWA	PA71870595	06/15/2017	\$35.75		06/15/2017		R&R-Invoice	Payroll Generated Invoice
00877	MASE/CWA	PA71870593	06/15/2017	\$35.34		06/15/2017		R&R-Invoice	Payroll Generated Invoice
00523	AFLAC	PA71870265	06/15/2017	\$34.01		06/15/2017		R&R-Invoice	Payroll Generated Invoice
00657	COLONIAL LIFE & ACCIDENT CO.	PA71870439	06/15/2017	\$34.02		06/15/2017		R&R-Invoice	Payroll Generated Invoice
00848	JACKSON FIREFIGHTERS ASSOC	PA71870537	06/15/2017	\$34.62		06/15/2017		R&R-Invoice	Payroll Generated Invoice
00415	LIFE OF ALABAMA	PA71870008	06/15/2017	\$33.94		06/15/2017		R&R-Invoice	Payroll Generated Invoice
00523	AFLAC	PA71870273	06/15/2017	\$33.06		06/15/2017		R&R-Invoice	Payroll Generated Invoice
00523	AFLAC	PA71870297	06/15/2017	\$33.84		06/15/2017		R&R-Invoice	Payroll Generated Invoice
00432	H D CATCHINGS AGENCY	PA71870083	06/15/2017	\$32.55		06/15/2017		R&R-Invoice	Payroll Generated Invoice
00523	AFLAC	PA71870206	06/15/2017	\$32.10		06/15/2017		R&R-Invoice	Payroll Generated Invoice
00523	AFLAC	PA71870251	06/15/2017	\$32.16		06/15/2017		R&R-Invoice	Payroll Generated Invoice
00523	AFLAC	PA71870293	06/15/2017	\$32.68		06/15/2017		R&R-Invoice	Payroll Generated Invoice
00529	POLICE HOSPITAL FUND	PA71870319	06/15/2017	\$32.34		06/15/2017		R&R-Invoice	Payroll Generated Invoice
00657	COLONIAL LIFE & ACCIDENT CO.	PA71870420	06/15/2017	\$32.04		06/15/2017		R&R-Invoice	Payroll Generated Invoice
00657	COLONIAL LIFE & ACCIDENT CO.	PA71870423	06/15/2017	\$32.40		06/15/2017		R&R-Invoice	Payroll Generated Invoice
66394	COMPBENEFITS	PA71870770	06/15/2017	\$32.49		06/15/2017		R&R-Invoice	Payroll Generated Invoice
00432	H D CATCHINGS AGENCY	PA71870062	06/15/2017	\$31.12		06/15/2017		R&R-Invoice	Payroll Generated Invoice
00523	AFLAC	PA71870276	06/15/2017	\$31.08		06/15/2017		R&R-Invoice	Payroll Generated Invoice
00765	AMERICAN HERITAGE LIFE INSURAN	PA71870510	06/15/2017	\$31.90		06/15/2017		R&R-Invoice	Payroll Generated Invoice
00765	AMERICAN HERITAGE LIFE INSURAN	PA71870517	06/15/2017	\$31.90		06/15/2017		R&R-Invoice	Payroll Generated Invoice
00877	MASE/CWA	PA71640095	06/09/2017	\$31.74		06/09/2017		R&R-Invoice	Payroll Generated Invoice
00877	MASE/CWA	PA71870574	06/15/2017	\$31.06		06/15/2017		R&R-Invoice	Payroll Generated Invoice
00877	MASE/CWA	PA71880093	06/16/2017	\$31.74		06/16/2017		R&R-Invoice	Payroll Generated Invoice
65572	UNUM PROVIDENT LIFE & ACCIDENT	PA71870741	06/15/2017	\$31.72		06/15/2017		R&R-Invoice	Payroll Generated Invoice
66394	COMPBENEFITS	PA71870761	06/15/2017	\$31.83		06/15/2017		R&R-Invoice	Payroll Generated Invoice
66394	COMPBENEFITS	PA71870810	06/15/2017	\$31.83		06/15/2017		R&R-Invoice	Payroll Generated Invoice
66394	COMPBENEFITS	PA71870811	06/15/2017	\$31.83		06/15/2017		R&R-Invoice	Payroll Generated Invoice
66394	COMPBENEFITS	PA71870884	06/15/2017	\$31.83		06/15/2017		R&R-Invoice	Payroll Generated Invoice
66394	COMPBENEFITS	PA71870914	06/15/2017	\$31.83		06/15/2017		R&R-Invoice	Payroll Generated Invoice
00415	LIFE OF ALABAMA	PA71640008	06/09/2017	\$30.06		06/09/2017		R&R-Invoice	Payroll Generated Invoice
00415	LIFE OF ALABAMA	PA71880008	06/16/2017	\$30.06		06/16/2017		R&R-Invoice	Payroll Generated Invoice
00432	H D CATCHINGS AGENCY	PA71870081	06/15/2017	\$30.95		06/15/2017		R&R-Invoice	Payroll Generated Invoice
00523	AFLAC	PA71640055	06/09/2017	\$30.81		06/09/2017		R&R-Invoice	Payroll Generated Invoice
00523	AFLAC	PA71870292	06/15/2017	\$30.84		06/15/2017		R&R-Invoice	Payroll Generated Invoice
00523	AFLAC	PA71870294	06/15/2017	\$30.18		06/15/2017		R&R-Invoice	Payroll Generated Invoice
00523	AFLAC	PA71880054	06/16/2017	\$30.81		06/16/2017		R&R-Invoice	Payroll Generated Invoice
00765	AMERICAN HERITAGE LIFE INSURAN	PA71870522	06/15/2017	\$30.93		06/15/2017		R&R-Invoice	Payroll Generated Invoice
00415	LIFE OF ALABAMA	PA71870040	06/15/2017	\$29.28		06/15/2017		R&R-Invoice	Payroll Generated Invoice
00415	LIFE OF ALABAMA	PA71870046	06/15/2017	\$29.45		06/15/2017		R&R-Invoice	Payroll Generated Invoice
00432	H D CATCHINGS AGENCY	PA71870100	06/15/2017	\$29.64		06/15/2017		R&R-Invoice	Payroll Generated Invoice
00448	PENNSYLVANIA LIFE INSURANCE CO	PA71870133	06/15/2017	\$29.40		06/15/2017		R&R-Invoice	Payroll Generated Invoice

AP757 VENDOR PAYMENTS / FOR CLAIM DOCKET - 06/27/2017
 REPORT TITLE - AMOUNTS (DESCENDING) ALL TYPES
 Invoice Payments Under 5500

VEN#	VENDOR-NAME	INVOICE	INV-DATE	AMOUNT	AUTHORIZATION	DUE-DATE	REF-NUMBER	PAYMENT-TYPE	REMARKS
00523	AFLAC	PA71870256	06/15/2017	\$29.82		06/15/2017		R&R-Invoice	Payroll Generated Invoice
00523	AFLAC	PA71870278	06/15/2017	\$29.72		06/15/2017		R&R-Invoice	Payroll Generated Invoice
00523	AFLAC	PA71870298	06/15/2017	\$29.86		06/15/2017		R&R-Invoice	Payroll Generated Invoice
00653	AMERICAN-AMICABLE LIFE INSURAN	PA71870387	06/15/2017	\$29.59		06/15/2017		R&R-Invoice	Payroll Generated Invoice
00653	AMERICAN-AMICABLE LIFE INSURAN	PA71870391	06/15/2017	\$30.00		06/15/2017		R&R-Invoice	Payroll Generated Invoice
00765	AMERICAN HERITAGE LIFE INSURAN	PA71870496	06/15/2017	\$29.52		06/15/2017		R&R-Invoice	Payroll Generated Invoice
00765	AMERICAN HERITAGE LIFE INSURAN	PA71870515	06/15/2017	\$29.16		06/15/2017		R&R-Invoice	Payroll Generated Invoice
00877	MASE/CWA	PA71870548	06/15/2017	\$29.58		06/15/2017		R&R-Invoice	Payroll Generated Invoice
00877	MASE/CWA	PA71870563	06/15/2017	\$29.22		06/15/2017		R&R-Invoice	Payroll Generated Invoice
00877	MASE/CWA	PA71870597	06/15/2017	\$29.88		06/15/2017		R&R-Invoice	Payroll Generated Invoice
60028	3P BENEFIT SOLUTIONS LLC	PA71870667	06/15/2017	\$30.00		06/15/2017		R&R-Invoice	Payroll Generated Invoice
60028	3P BENEFIT SOLUTIONS LLC	PA71870683	06/15/2017	\$30.00		06/15/2017		R&R-Invoice	Payroll Generated Invoice
60028	3P BENEFIT SOLUTIONS LLC	PA71870703	06/15/2017	\$30.00		06/15/2017		R&R-Invoice	Payroll Generated Invoice
00411	AMERICAN PUBLIC LIFE INS CO	PA71870003	06/15/2017	\$28.63		06/15/2017		R&R-Invoice	Payroll Generated Invoice
00432	H D CATCHINGS AGENCY	PA71870066	06/15/2017	\$28.08		06/15/2017		R&R-Invoice	Payroll Generated Invoice
00432	H D CATCHINGS AGENCY	PA71870073	06/15/2017	\$28.30		06/15/2017		R&R-Invoice	Payroll Generated Invoice
00657	COLONIAL LIFE & ACCIDENT CO.	PA71870427	06/15/2017	\$28.81		06/15/2017		R&R-Invoice	Payroll Generated Invoice
00764	OCCIDENTAL LIFE INSURANCE CO	PA71870487	06/15/2017	\$28.20		06/15/2017		R&R-Invoice	Payroll Generated Invoice
00765	AMERICAN HERITAGE LIFE INSURAN	PA71640081	06/09/2017	\$28.17		06/09/2017		R&R-Invoice	Payroll Generated Invoice
00765	AMERICAN HERITAGE LIFE INSURAN	PA71880079	06/16/2017	\$28.17		06/16/2017		R&R-Invoice	Payroll Generated Invoice
06867	GENERAL FUND	PA71870645	06/15/2017	\$28.26		06/15/2017		R&R-Invoice	Payroll Generated Invoice
00531	JRA PARKING	PA71870332	06/15/2017	\$27.72		06/15/2017		R&R-Invoice	Payroll Generated Invoice
00531	JRA PARKING	PA71870338	06/15/2017	\$27.72		06/15/2017		R&R-Invoice	Payroll Generated Invoice
00531	JRA PARKING	PA71870358	06/15/2017	\$27.72		06/15/2017		R&R-Invoice	Payroll Generated Invoice
00531	JRA PARKING	PA71870370	06/15/2017	\$27.72		06/15/2017		R&R-Invoice	Payroll Generated Invoice
00657	COLONIAL LIFE & ACCIDENT CO.	PA71870412	06/15/2017	\$27.31		06/15/2017		R&R-Invoice	Payroll Generated Invoice
00657	COLONIAL LIFE & ACCIDENT CO.	PA71870452	06/15/2017	\$27.46		06/15/2017		R&R-Invoice	Payroll Generated Invoice
00657	COLONIAL LIFE & ACCIDENT CO.	PA71870456	06/15/2017	\$27.16		06/15/2017		R&R-Invoice	Payroll Generated Invoice
65572	UNUM PROVIDENT LIFE & ACCIDENT	PA71640114	06/09/2017	\$27.47		06/09/2017		R&R-Invoice	Payroll Generated Invoice
65572	UNUM PROVIDENT LIFE & ACCIDENT	PA71870739	06/15/2017	\$27.54		06/15/2017		R&R-Invoice	Payroll Generated Invoice
65572	UNUM PROVIDENT LIFE & ACCIDENT	PA71880112	06/16/2017	\$27.47		06/16/2017		R&R-Invoice	Payroll Generated Invoice
00415	LIFE OF ALABAMA	PA71870022	06/15/2017	\$26.96		06/15/2017		R&R-Invoice	Payroll Generated Invoice
00432	H D CATCHINGS AGENCY	PA71640018	06/09/2017	\$26.67		06/09/2017		R&R-Invoice	Payroll Generated Invoice
00432	H D CATCHINGS AGENCY	PA71870106	06/15/2017	\$26.37		06/15/2017		R&R-Invoice	Payroll Generated Invoice
00432	H D CATCHINGS AGENCY	PA71880018	06/16/2017	\$26.67		06/16/2017		R&R-Invoice	Payroll Generated Invoice
00448	PENNSYLVANIA LIFE INSURANCE CO	PA71870143	06/15/2017	\$26.28		06/15/2017		R&R-Invoice	Payroll Generated Invoice
00523	AFLAC	PA71870207	06/15/2017	\$27.00		06/15/2017		R&R-Invoice	Payroll Generated Invoice
00523	AFLAC	PA71870214	06/15/2017	\$26.88		06/15/2017		R&R-Invoice	Payroll Generated Invoice
00523	AFLAC	PA71870254	06/15/2017	\$26.04		06/15/2017		R&R-Invoice	Payroll Generated Invoice
00658	PROVIDENT INSURANCE	PA71870465	06/15/2017	\$26.82		06/15/2017		R&R-Invoice	Payroll Generated Invoice
00877	MASE/CWA	PA71870577	06/15/2017	\$26.99		06/15/2017		R&R-Invoice	Payroll Generated Invoice
00877	MASE/CWA	PA71870584	06/15/2017	\$26.85		06/15/2017		R&R-Invoice	Payroll Generated Invoice
00415	LIFE OF ALABAMA	PA71870042	06/15/2017	\$25.20		06/15/2017		R&R-Invoice	Payroll Generated Invoice

AP757

VENDOR PAYMENTS / FOR CLAIM DOCKET - 06/27/2017
 REPORT TITLE - AMOUNTS (DESCENDING) ALL TYPES
 Invoice Payments Under \$500

VEN#	VENDOR-NAME	INVOICE	INV-DATE	AMOUNT	AUTHORIZATION	DUE-DATE	REF-NUMBER	PAYMENT-TYPE	REMARKS
00432	H D CATCHINGS AGENCY	PA71870086	06/15/2017	\$25.89		06/15/2017		R&R-Invoice	Payroll Generated Invoice
00523	AFLAC	PA71870275	06/15/2017	\$25.20		06/15/2017		R&R-Invoice	Payroll Generated Invoice
00653	AMERICAN-AMICABLE LIFE INSURAN	PA71870385	06/15/2017	\$25.45		06/15/2017		R&R-Invoice	Payroll Generated Invoice
00764	OCCIDENTAL LIFE INSURANCE CO	PA71870488	06/15/2017	\$25.74		06/15/2017		R&R-Invoice	Payroll Generated Invoice
00764	OCCIDENTAL LIFE INSURANCE CO	PA71870490	06/15/2017	\$25.28		06/15/2017		R&R-Invoice	Payroll Generated Invoice
00765	AMERICAN HERITAGE LIFE INSURAN	PA71870513	06/15/2017	\$25.78		06/15/2017		R&R-Invoice	Payroll Generated Invoice
00478	UNITED WAY	PA71870160	06/15/2017	\$25.00		06/15/2017		R&R-Invoice	Payroll Generated Invoice
00653	AMERICAN-AMICABLE LIFE INSURAN	PA71640064	06/09/2017	\$25.00		06/09/2017		R&R-Invoice	Payroll Generated Invoice
00653	AMERICAN-AMICABLE LIFE INSURAN	PA71870390	06/15/2017	\$25.00		06/15/2017		R&R-Invoice	Payroll Generated Invoice
00653	AMERICAN-AMICABLE LIFE INSURAN	PA71870401	06/15/2017	\$25.00		06/15/2017		R&R-Invoice	Payroll Generated Invoice
00653	AMERICAN-AMICABLE LIFE INSURAN	PA71870403	06/15/2017	\$25.00		06/15/2017		R&R-Invoice	Payroll Generated Invoice
00653	AMERICAN-AMICABLE LIFE INSURAN	PA71870406	06/15/2017	\$25.00		06/15/2017		R&R-Invoice	Payroll Generated Invoice
00653	AMERICAN-AMICABLE LIFE INSURAN	PA71870410	06/15/2017	\$25.00		06/15/2017		R&R-Invoice	Payroll Generated Invoice
00653	AMERICAN-AMICABLE LIFE INSURAN	PA71880063	06/16/2017	\$25.00		06/16/2017		R&R-Invoice	Payroll Generated Invoice
00657	COLONIAL LIFE & ACCIDENT CO.	PA71640073	06/09/2017	\$24.69		06/09/2017		R&R-Invoice	Payroll Generated Invoice
00657	COLONIAL LIFE & ACCIDENT CO.	PA71870446	06/15/2017	\$24.20		06/15/2017		R&R-Invoice	Payroll Generated Invoice
00657	COLONIAL LIFE & ACCIDENT CO.	PA71870453	06/15/2017	\$24.86		06/15/2017		R&R-Invoice	Payroll Generated Invoice
00657	COLONIAL LIFE & ACCIDENT CO.	PA71880072	06/16/2017	\$24.69		06/16/2017		R&R-Invoice	Payroll Generated Invoice
00658	PROVIDENT INSURANCE	PA71870458	06/15/2017	\$24.41		06/15/2017		R&R-Invoice	Payroll Generated Invoice
00764	OCCIDENTAL LIFE INSURANCE CO	PA71870484	06/15/2017	\$24.41		06/15/2017		R&R-Invoice	Payroll Generated Invoice
00764	OCCIDENTAL LIFE INSURANCE CO	PA71870493	06/15/2017	\$24.17		06/15/2017		R&R-Invoice	Payroll Generated Invoice
00765	AMERICAN HERITAGE LIFE INSURAN	PA71640083	06/09/2017	\$24.29		06/09/2017		R&R-Invoice	Payroll Generated Invoice
00765	AMERICAN HERITAGE LIFE INSURAN	PA71870523	06/15/2017	\$24.81		06/15/2017		R&R-Invoice	Payroll Generated Invoice
00765	AMERICAN HERITAGE LIFE INSURAN	PA71880081	06/16/2017	\$24.29		06/16/2017		R&R-Invoice	Payroll Generated Invoice
60028	3P BENEFIT SOLUTIONS LLC	PA71870709	06/15/2017	\$25.00		06/15/2017		R&R-Invoice	Payroll Generated Invoice
65572	UNUM PROVIDENT LIFE & ACCIDENT	PA71870734	06/15/2017	\$24.84		06/15/2017		R&R-Invoice	Payroll Generated Invoice
00415	LIFE OF ALABAMA	PA71870012	06/15/2017	\$23.66		06/15/2017		R&R-Invoice	Payroll Generated Invoice
00415	LIFE OF ALABAMA	PA71870020	06/15/2017	\$23.58		06/15/2017		R&R-Invoice	Payroll Generated Invoice
00523	AFLAC	PA71870228	06/15/2017	\$24.00		06/15/2017		R&R-Invoice	Payroll Generated Invoice
00523	AFLAC	PA71870257	06/15/2017	\$23.22		06/15/2017		R&R-Invoice	Payroll Generated Invoice
00523	AFLAC	PA71870258	06/15/2017	\$23.52		06/15/2017		R&R-Invoice	Payroll Generated Invoice
00764	OCCIDENTAL LIFE INSURANCE CO	PA71640079	06/09/2017	\$23.95		06/09/2017		R&R-Invoice	Payroll Generated Invoice
00764	OCCIDENTAL LIFE INSURANCE CO	PA71880077	06/16/2017	\$23.95		06/16/2017		R&R-Invoice	Payroll Generated Invoice
00765	AMERICAN HERITAGE LIFE INSURAN	PA71870507	06/15/2017	\$23.86		06/15/2017		R&R-Invoice	Payroll Generated Invoice
00765	AMERICAN HERITAGE LIFE INSURAN	PA71870519	06/15/2017	\$23.10		06/15/2017		R&R-Invoice	Payroll Generated Invoice
00765	AMERICAN HERITAGE LIFE INSURAN	PA71870528	06/15/2017	\$23.30		06/15/2017		R&R-Invoice	Payroll Generated Invoice
00848	JACKSON FIREFIGHTERS ASSOC	PA71870536	06/15/2017	\$23.08		06/15/2017		R&R-Invoice	Payroll Generated Invoice
00877	MASE/CWA	PA71870557	06/15/2017	\$23.12		06/15/2017		R&R-Invoice	Payroll Generated Invoice
00877	MASE/CWA	PA71870570	06/15/2017	\$23.01		06/15/2017		R&R-Invoice	Payroll Generated Invoice
00877	MASE/CWA	PA71870571	06/15/2017	\$23.03		06/15/2017		R&R-Invoice	Payroll Generated Invoice
00415	LIFE OF ALABAMA	PA71870034	06/15/2017	\$22.95		06/15/2017		R&R-Invoice	Payroll Generated Invoice
00415	LIFE OF ALABAMA	PA71870039	06/15/2017	\$22.15		06/15/2017		R&R-Invoice	Payroll Generated Invoice
00432	H D CATCHINGS AGENCY	PA71640025	06/09/2017	\$22.13		06/09/2017		R&R-Invoice	Payroll Generated Invoice

AP757 VENDOR PAYMENTS / FOR CLAIM DOCKET - 06/27/2017
 REPORT TITLE - AMOUNTS (DESCENDING) ALL TYPES
 Invoice Payments Under \$500

VEN#	VENDOR-NAME	INVOICE	INV-DATE	AMOUNT	AUTHORIZATION	DUE-DATE	REF-NUMBER	PAYMENT-TYPE	REMARKS
00432	H D CATCHINGS AGENCY	PA1870078	06/15/2017	\$22.49		06/15/2017		R&R-Invoice	Payroll Generated Invoice
00432	H D CATCHINGS AGENCY	PA1870088	06/15/2017	\$22.71		06/15/2017		R&R-Invoice	Payroll Generated Invoice
00432	H D CATCHINGS AGENCY	PA1870094	06/15/2017	\$22.44		06/15/2017		R&R-Invoice	Payroll Generated Invoice
00432	H D CATCHINGS AGENCY	PA1880025	06/16/2017	\$22.13		06/16/2017		R&R-Invoice	Payroll Generated Invoice
00499	MS DEPARTMENT OF REVENUE (DOR)	PA11880030	06/16/2017	\$22.63		06/16/2017		R&R-Invoice	Payroll Generated Invoice
00877	MASE/CWA	PA11640103	06/09/2017	\$22.54		06/09/2017		R&R-Invoice	Payroll Generated Invoice
00877	MASE/CWA	PA1870562	06/15/2017	\$22.80		06/15/2017		R&R-Invoice	Payroll Generated Invoice
00877	MASE/CWA	PA1870582	06/15/2017	\$22.11		06/15/2017		R&R-Invoice	Payroll Generated Invoice
00877	MASE/CWA	PA1880101	06/16/2017	\$22.54		06/16/2017		R&R-Invoice	Payroll Generated Invoice
00944	PRE-PAID LEGAL SERVICES INC	PA1870622	06/15/2017	\$22.08		06/15/2017		R&R-Invoice	Payroll Generated Invoice
06667	GENERAL FUND	PA1870650	06/15/2017	\$22.50		06/15/2017		R&R-Invoice	Payroll Generated Invoice
06667	GENERAL FUND	PA1870658	06/15/2017	\$22.50		06/15/2017		R&R-Invoice	Payroll Generated Invoice
60028	3P BENEFIT SOLUTIONS LLC	PA1870660	06/15/2017	\$23.00		06/15/2017		R&R-Invoice	Payroll Generated Invoice
00415	LIFE OF ALABAMA	PA11640004	06/09/2017	\$21.78		06/09/2017		R&R-Invoice	Payroll Generated Invoice
00415	LIFE OF ALABAMA	PA1870013	06/15/2017	\$21.76		06/15/2017		R&R-Invoice	Payroll Generated Invoice
00415	LIFE OF ALABAMA	PA1870028	06/15/2017	\$21.77		06/15/2017		R&R-Invoice	Payroll Generated Invoice
00415	LIFE OF ALABAMA	PA1870033	06/15/2017	\$21.76		06/15/2017		R&R-Invoice	Payroll Generated Invoice
00415	LIFE OF ALABAMA	PA18860004	06/16/2017	\$21.78		06/16/2017		R&R-Invoice	Payroll Generated Invoice
00432	H D CATCHINGS AGENCY	PA11640017	06/09/2017	\$21.09		06/09/2017		R&R-Invoice	Payroll Generated Invoice
00653	AMERICAN-AMICABLE LIFE INSURAN	PA1870389	06/15/2017	\$21.06		06/15/2017		R&R-Invoice	Payroll Generated Invoice
00653	AMERICAN-AMICABLE LIFE INSURAN	PA1870404	06/15/2017	\$21.32		06/15/2017		R&R-Invoice	Payroll Generated Invoice
00657	COLONIAL LIFE & ACCIDENT CO.	PA1870441	06/15/2017	\$21.07		06/15/2017		R&R-Invoice	Payroll Generated Invoice
00657	COLONIAL LIFE & ACCIDENT CO.	PA1870442	06/15/2017	\$21.11		06/15/2017		R&R-Invoice	Payroll Generated Invoice
00658	PROVIDENT INSURANCE	PA1870462	06/15/2017	\$21.12		06/15/2017		R&R-Invoice	Payroll Generated Invoice
00764	OCCIDENTAL LIFE INSURANCE CO	PA1870494	06/15/2017	\$21.87		06/15/2017		R&R-Invoice	Payroll Generated Invoice
00765	AMERICAN HERITAGE LIFE INSURAN	PA71640084	06/09/2017	\$21.67		06/09/2017		R&R-Invoice	Payroll Generated Invoice
00765	AMERICAN HERITAGE LIFE INSURAN	PA71880082	06/16/2017	\$21.82		06/16/2017		R&R-Invoice	Payroll Generated Invoice
65572	UNUM PROVIDENT LIFE & ACCIDENT	PA71870719	06/15/2017	\$21.82		06/15/2017		R&R-Invoice	Payroll Generated Invoice
65572	UNUM PROVIDENT LIFE & ACCIDENT	PA71870733	06/15/2017	\$21.82		06/15/2017		R&R-Invoice	Payroll Generated Invoice
66394	COMPBENEFITS	PA71870777	06/15/2017	\$21.22		06/15/2017		R&R-Invoice	Payroll Generated Invoice
66394	COMPBENEFITS	PA71870800	06/15/2017	\$21.22		06/15/2017		R&R-Invoice	Payroll Generated Invoice
66394	COMPBENEFITS	PA71870830	06/15/2017	\$21.66		06/15/2017		R&R-Invoice	Payroll Generated Invoice
66394	COMPBENEFITS	PA71870849	06/15/2017	\$21.22		06/15/2017		R&R-Invoice	Payroll Generated Invoice
66394	COMPBENEFITS	PA71870851	06/15/2017	\$21.63		06/15/2017		R&R-Invoice	Payroll Generated Invoice
66394	COMPBENEFITS	PA71870856	06/15/2017	\$21.63		06/15/2017		R&R-Invoice	Payroll Generated Invoice
66394	COMPBENEFITS	PA71870910	06/15/2017	\$21.66		06/15/2017		R&R-Invoice	Payroll Generated Invoice
70874	SOUTHERN STATES POLICE BENEVL	PA71870925	06/15/2017	\$21.70		06/15/2017		R&R-Invoice	Payroll Generated Invoice
00415	LIFE OF ALABAMA	PA71640001	06/09/2017	\$20.26		06/09/2017		R&R-Invoice	Payroll Generated Invoice
00415	LIFE OF ALABAMA	PA71880001	06/16/2017	\$20.26		06/16/2017		R&R-Invoice	Payroll Generated Invoice
00448	PENNSYLVANIA LIFE INSURANCE CO	PA71870132	06/15/2017	\$20.46		06/15/2017		R&R-Invoice	Payroll Generated Invoice
00478	UNITED WAY	PA71870161	06/15/2017	\$20.83		06/15/2017		R&R-Invoice	Payroll Generated Invoice
00523	AFLAC	PA71870255	06/15/2017	\$20.58		06/15/2017		R&R-Invoice	Payroll Generated Invoice
00523	AFLAC	PA71870268	06/15/2017	\$20.10		06/15/2017		R&R-Invoice	Payroll Generated Invoice

AP757 VENDOR PAYMENTS / FOR CLAIM DOCKET - 06/27/2017
 REPORT TITLE - AMOUNTS (DESCENDING) ALL TYPES
 Invoice Payments Under \$500

VEN#	VENDOR-NAME	INVOICE	INV-DATE	AMOUNT	AUTHORIZATION	DUE-DATE	REF-NUMBER	PAYMENT-TYPE	REMARKS
00523	AFLAC	PA71870299	06/15/2017	\$20.10		06/15/2017		R&R-Invoice	Payroll Generated Invoice
00765	AMERICAN HERITAGE LIFE INSURAN	PA71870516	06/15/2017	\$20.50		06/15/2017		R&R-Invoice	Payroll Generated Invoice
00765	AMERICAN HERITAGE LIFE INSURAN	PA71870527	06/15/2017	\$20.61		06/15/2017		R&R-Invoice	Payroll Generated Invoice
00877	MASE/CWA	PA71870551	06/15/2017	\$20.40		06/15/2017		R&R-Invoice	Payroll Generated Invoice
00877	MASE/CWA	PA71870555	06/15/2017	\$20.85		06/15/2017		R&R-Invoice	Payroll Generated Invoice
00877	MASE/CWA	PA71870568	06/15/2017	\$20.64		06/15/2017		R&R-Invoice	Payroll Generated Invoice
00415	LIFE OF ALABAMA	PA71640013	06/09/2017	\$19.96		06/09/2017		R&R-Invoice	Payroll Generated Invoice
00415	LIFE OF ALABAMA	PA71880013	06/16/2017	\$19.96		06/16/2017		R&R-Invoice	Payroll Generated Invoice
00432	H D CATCHINGS AGENCY	PA71870079	06/15/2017	\$19.82		06/15/2017		R&R-Invoice	Payroll Generated Invoice
00432	H D CATCHINGS AGENCY	PA71870107	06/15/2017	\$19.62		06/15/2017		R&R-Invoice	Payroll Generated Invoice
00448	PENNSYLVANIA LIFE INSURANCE CO	PA71870130	06/15/2017	\$19.86		06/15/2017		R&R-Invoice	Payroll Generated Invoice
00523	AFLAC	PA71870220	06/15/2017	\$19.26		06/15/2017		R&R-Invoice	Payroll Generated Invoice
00523	AFLAC	PA71870284	06/15/2017	\$19.26		06/15/2017		R&R-Invoice	Payroll Generated Invoice
00523	AFLAC	PA71870267	06/15/2017	\$19.08		06/15/2017		R&R-Invoice	Payroll Generated Invoice
00523	AFLAC	PA71870282	06/15/2017	\$19.93		06/15/2017		R&R-Invoice	Payroll Generated Invoice
00523	AFLAC	PA71870302	06/15/2017	\$19.84		06/15/2017		R&R-Invoice	Payroll Generated Invoice
00523	AFLAC	PA71870304	06/15/2017	\$19.26		06/15/2017		R&R-Invoice	Payroll Generated Invoice
00653	AMERICAN-AMICABLE LIFE INSURAN	PA71870382	06/15/2017	\$19.99		06/15/2017		R&R-Invoice	Payroll Generated Invoice
00657	COLONIAL LIFE & ACCIDENT CO.	PA71870417	06/15/2017	\$19.02		06/15/2017		R&R-Invoice	Payroll Generated Invoice
00658	PROVIDENT INSURANCE	PA71870463	06/15/2017	\$19.35		06/15/2017		R&R-Invoice	Payroll Generated Invoice
00765	AMERICAN HERITAGE LIFE INSURAN	PA71870498	06/15/2017	\$19.66		06/15/2017		R&R-Invoice	Payroll Generated Invoice
00877	MASE/CWA	PA71870544	06/15/2017	\$19.68		06/15/2017		R&R-Invoice	Payroll Generated Invoice
60028	3P BENEFIT SOLUTIONS LLC	PA71870666	06/15/2017	\$20.00		06/15/2017		R&R-Invoice	Payroll Generated Invoice
60028	3P BENEFIT SOLUTIONS LLC	PA71870673	06/15/2017	\$19.24		06/15/2017		R&R-Invoice	Payroll Generated Invoice
60028	3P BENEFIT SOLUTIONS LLC	PA71870689	06/15/2017	\$20.00		06/15/2017		R&R-Invoice	Payroll Generated Invoice
60028	3P BENEFIT SOLUTIONS LLC	PA71870697	06/15/2017	\$19.23		06/15/2017		R&R-Invoice	Payroll Generated Invoice
60028	3P BENEFIT SOLUTIONS LLC	PA71870701	06/15/2017	\$20.00		06/15/2017		R&R-Invoice	Payroll Generated Invoice
65572	UNUM PROVIDENT LIFE & ACCIDENT	PA71870725	06/15/2017	\$19.30		06/15/2017		R&R-Invoice	Payroll Generated Invoice
65572	UNUM PROVIDENT LIFE & ACCIDENT	PA71870732	06/15/2017	\$19.40		06/15/2017		R&R-Invoice	Payroll Generated Invoice
00415	LIFE OF ALABAMA	PA71870029	06/15/2017	\$18.15		06/15/2017		R&R-Invoice	Payroll Generated Invoice
00432	H D CATCHINGS AGENCY	PA71870096	06/15/2017	\$18.59		06/15/2017		R&R-Invoice	Payroll Generated Invoice
00448	PENNSYLVANIA LIFE INSURANCE CO	PA71640027	06/09/2017	\$18.54		06/09/2017		R&R-Invoice	Payroll Generated Invoice
00448	PENNSYLVANIA LIFE INSURANCE CO	PA71880027	06/16/2017	\$18.54		06/16/2017		R&R-Invoice	Payroll Generated Invoice
00523	AFLAC	PA71640048	06/09/2017	\$18.85		06/09/2017		R&R-Invoice	Payroll Generated Invoice
00523	AFLAC	PA71870222	06/15/2017	\$18.42		06/15/2017		R&R-Invoice	Payroll Generated Invoice
00523	AFLAC	PA71870236	06/15/2017	\$18.90		06/15/2017		R&R-Invoice	Payroll Generated Invoice
00523	AFLAC	PA71870238	06/15/2017	\$18.49		06/15/2017		R&R-Invoice	Payroll Generated Invoice
00523	AFLAC	PA71870261	06/15/2017	\$18.84		06/15/2017		R&R-Invoice	Payroll Generated Invoice
00523	AFLAC	PA71880047	06/16/2017	\$18.85		06/16/2017		R&R-Invoice	Payroll Generated Invoice
00529	POLICE HOSPITAL FUND	PA71870311	06/15/2017	\$18.48		06/15/2017		R&R-Invoice	Payroll Generated Invoice
00530	AMERICAN GENERAL LIFE	PA71870322	06/15/2017	\$18.96		06/15/2017		R&R-Invoice	Payroll Generated Invoice
00531	JRA PARKING	PA71870326	06/15/2017	\$18.48		06/15/2017		R&R-Invoice	Payroll Generated Invoice
00531	JRA PARKING	PA71870327	06/15/2017	\$18.48		06/15/2017		R&R-Invoice	Payroll Generated Invoice

AP757
 VENDOR PAYMENTS / FOR CLAIM DOCKET - 06/27/2017
 REPORT TITLE - AMOUNTS (DESCENDING) ALL TYPES
 Invoice Payments Under \$500

VEN#	VENDOR-NAME	INVOICE	INV-DATE	AMOUNT	AUTHORIZATION	DUE-DATE	REF-NUMBER	PAYMENT-TYPE	REMARKS
00531	JRA PARKING	PA71870329	06/15/2017	\$18.48		06/15/2017		R&R-Invoice	Payroll Generated Invoice
00531	JRA PARKING	PA71870336	06/15/2017	\$18.48		06/15/2017		R&R-Invoice	Payroll Generated Invoice
00531	JRA PARKING	PA71870339	06/15/2017	\$18.48		06/15/2017		R&R-Invoice	Payroll Generated Invoice
00531	JRA PARKING	PA71870341	06/15/2017	\$18.48		06/15/2017		R&R-Invoice	Payroll Generated Invoice
00531	JRA PARKING	PA71870348	06/15/2017	\$18.48		06/15/2017		R&R-Invoice	Payroll Generated Invoice
00531	JRA PARKING	PA71870362	06/15/2017	\$18.48		06/15/2017		R&R-Invoice	Payroll Generated Invoice
00531	JRA PARKING	PA71870364	06/15/2017	\$18.48		06/15/2017		R&R-Invoice	Payroll Generated Invoice
00531	JRA PARKING	PA71870365	06/15/2017	\$18.48		06/15/2017		R&R-Invoice	Payroll Generated Invoice
00531	JRA PARKING	PA71870367	06/15/2017	\$18.48		06/15/2017		R&R-Invoice	Payroll Generated Invoice
00531	JRA PARKING	PA71870368	06/15/2017	\$18.48		06/15/2017		R&R-Invoice	Payroll Generated Invoice
00657	COLONIAL LIFE & ACCIDENT CO.	PA71870424	06/15/2017	\$18.69		06/15/2017		R&R-Invoice	Payroll Generated Invoice
00657	COLONIAL LIFE & ACCIDENT CO.	PA71870450	06/15/2017	\$18.99		06/15/2017		R&R-Invoice	Payroll Generated Invoice
00877	MASE/CWA	PA71870550	06/15/2017	\$19.00		06/15/2017		R&R-Invoice	Payroll Generated Invoice
00877	MASE/CWA	PA71870561	06/15/2017	\$19.00		06/15/2017		R&R-Invoice	Payroll Generated Invoice
00877	MASE/CWA	PA71870565	06/15/2017	\$18.15		06/15/2017		R&R-Invoice	Payroll Generated Invoice
60028	3P BENEFIT SOLUTIONS LLC	PA71870693	06/15/2017	\$19.00		06/15/2017		R&R-Invoice	Payroll Generated Invoice
65572	UNUM PROVIDENT LIFE & ACCIDENT	PA71870735	06/15/2017	\$18.36		06/15/2017		R&R-Invoice	Payroll Generated Invoice
6572	UNUM PROVIDENT LIFE & ACCIDENT	PA71870736	06/15/2017	\$18.36		06/15/2017		R&R-Invoice	Payroll Generated Invoice
66394	COMPBENEFITS	PA71870850	06/15/2017	\$18.05		06/15/2017		R&R-Invoice	Payroll Generated Invoice
66394	COMPBENEFITS	PA71870909	06/15/2017	\$18.05		06/15/2017		R&R-Invoice	Payroll Generated Invoice
00432	H D CATCHINGS AGENCY	PA71640021	06/09/2017	\$17.92		06/09/2017		R&R-Invoice	Payroll Generated Invoice
00432	H D CATCHINGS AGENCY	PA71870075	06/15/2017	\$17.74		06/15/2017		R&R-Invoice	Payroll Generated Invoice
00432	H D CATCHINGS AGENCY	PA71870102	06/15/2017	\$17.83		06/15/2017		R&R-Invoice	Payroll Generated Invoice
00432	H D CATCHINGS AGENCY	PA71880021	06/16/2017	\$17.92		06/16/2017		R&R-Invoice	Payroll Generated Invoice
00445	J ALLEN SANDIFER AGENCY	PA71640046	06/09/2017	\$17.55		06/09/2017		R&R-Invoice	Payroll Generated Invoice
00523	AFLAC	PA71870211	06/15/2017	\$17.31		06/15/2017		R&R-Invoice	Payroll Generated Invoice
00523	AFLAC	PA71870216	06/15/2017	\$17.31		06/15/2017		R&R-Invoice	Payroll Generated Invoice
00523	AFLAC	PA71870279	06/15/2017	\$17.86		06/15/2017		R&R-Invoice	Payroll Generated Invoice
00523	AFLAC	PA71870395	06/15/2017	\$17.64		06/15/2017		R&R-Invoice	Payroll Generated Invoice
00523	AFLAC	PA71880045	06/16/2017	\$17.34		06/16/2017		R&R-Invoice	Payroll Generated Invoice
00657	COLONIAL LIFE & ACCIDENT CO.	PA71870425	06/15/2017	\$17.28		06/15/2017		R&R-Invoice	Payroll Generated Invoice
00765	AMERICAN HERITAGE LIFE INSURAN	PA71640082	06/09/2017	\$17.04		06/09/2017		R&R-Invoice	Payroll Generated Invoice
00765	AMERICAN HERITAGE LIFE INSURAN	PA71880080	06/16/2017	\$17.04		06/16/2017		R&R-Invoice	Payroll Generated Invoice
00877	MASE/CWA	PA71640102	06/09/2017	\$17.92		06/09/2017		R&R-Invoice	Payroll Generated Invoice
00877	MASE/CWA	PA71880100	06/16/2017	\$17.92		06/16/2017		R&R-Invoice	Payroll Generated Invoice
00415	LIFE OF ALABAMA	PA71640012	06/09/2017	\$16.51		06/09/2017		R&R-Invoice	Payroll Generated Invoice
00415	LIFE OF ALABAMA	PA71880012	06/16/2017	\$16.51		06/16/2017		R&R-Invoice	Payroll Generated Invoice
00448	PENNSYLVANIA LIFE INSURANCE CO	PA71870140	06/15/2017	\$16.96		06/15/2017		R&R-Invoice	Payroll Generated Invoice
00523	AFLAC	PA71640054	06/09/2017	\$16.61		06/09/2017		R&R-Invoice	Payroll Generated Invoice
00523	AFLAC	PA71880053	06/16/2017	\$16.61		06/16/2017		R&R-Invoice	Payroll Generated Invoice
00657	COLONIAL LIFE & ACCIDENT CO.	PA71870415	06/15/2017	\$16.60		06/15/2017		R&R-Invoice	Payroll Generated Invoice
00765	AMERICAN HERITAGE LIFE INSURAN	PA71870505	06/15/2017	\$16.40		06/15/2017		R&R-Invoice	Payroll Generated Invoice

AP757

VENDOR PAYMENTS / FOR CLAIM DOCKET - 06/27/2017
 REPORT TITLE - AMOUNTS (DESCENDING) ALL TYPES
 Invoice Payments Under \$500

VEN#	VENDOR-NAME	INVOICE	INV-DATE	AMOUNT	AUTHORIZATION	DUE-DATE	REF-NUMBER	PAYMENT-TYPE	REMARKS
00877	MASE/CWA	PA71870553	06/15/2017	\$16.54		06/15/2017		R&R-Invoice	Payroll Generated Invoice
00877	MASE/CWA	PA71870576	06/15/2017	\$16.54		06/15/2017		R&R-Invoice	Payroll Generated Invoice
00415	LIFE OF ALABAMA	PA71640005	06/09/2017	\$15.20		06/09/2017		R&R-Invoice	Payroll Generated Invoice
00415	LIFE OF ALABAMA	PA71640010	06/09/2017	\$15.20		06/09/2017		R&R-Invoice	Payroll Generated Invoice
00415	LIFE OF ALABAMA	PA71870018	06/15/2017	\$15.18		06/15/2017		R&R-Invoice	Payroll Generated Invoice
00415	LIFE OF ALABAMA	PA71880005	06/16/2017	\$15.20		06/16/2017		R&R-Invoice	Payroll Generated Invoice
00415	LIFE OF ALABAMA	PA71880010	06/16/2017	\$15.20		06/16/2017		R&R-Invoice	Payroll Generated Invoice
00432	H D CATCHINGS AGENCY	PA71870054	06/15/2017	\$15.14		06/15/2017		R&R-Invoice	Payroll Generated Invoice
00432	H D CATCHINGS AGENCY	PA71870104	06/15/2017	\$15.32		06/15/2017		R&R-Invoice	Payroll Generated Invoice
00448	PENNSYLVANIA LIFE INSURANCE CO	PA71870135	06/15/2017	\$15.17		06/15/2017		R&R-Invoice	Payroll Generated Invoice
00448	PENNSYLVANIA LIFE INSURANCE CO	PA71870141	06/15/2017	\$15.25		06/15/2017		R&R-Invoice	Payroll Generated Invoice
00523	AFLAC	PA71870226	06/15/2017	\$15.70		06/15/2017		R&R-Invoice	Payroll Generated Invoice
00657	COLONIAL LIFE & ACCIDENT CO.	PA71640072	06/09/2017	\$15.45		06/09/2017		R&R-Invoice	Payroll Generated Invoice
00657	COLONIAL LIFE & ACCIDENT CO.	PA71870455	06/15/2017	\$15.35		06/15/2017		R&R-Invoice	Payroll Generated Invoice
00657	COLONIAL LIFE & ACCIDENT CO.	PA71870457	06/15/2017	\$15.76		06/15/2017		R&R-Invoice	Payroll Generated Invoice
00657	COLONIAL LIFE & ACCIDENT CO.	PA71880071	06/16/2017	\$15.45		06/16/2017		R&R-Invoice	Payroll Generated Invoice
00658	PROVIDENT INSURANCE	PA71870459	06/15/2017	\$15.49		06/15/2017		R&R-Invoice	Payroll Generated Invoice
00765	AMERICAN HERITAGE LIFE INSURAN	PA71870518	06/15/2017	\$15.70		06/15/2017		R&R-Invoice	Payroll Generated Invoice
00877	MASE/CWA	PA71870586	06/15/2017	\$15.11		06/15/2017		R&R-Invoice	Payroll Generated Invoice
60028	3P BENEFIT SOLUTIONS LLC	PA71870661	06/15/2017	\$15.38		06/15/2017		R&R-Invoice	Payroll Generated Invoice
65572	UNUM PROVIDENT LIFE & ACCIDENT	PA71870714	06/15/2017	\$15.24		06/15/2017		R&R-Invoice	Payroll Generated Invoice
00411	AMERICAN PUBLIC LIFE INS CO	PA71870002	06/15/2017	\$14.41		06/15/2017		R&R-Invoice	Payroll Generated Invoice
00432	H D CATCHINGS AGENCY	PA71870071	06/15/2017	\$14.44		06/15/2017		R&R-Invoice	Payroll Generated Invoice
00432	H D CATCHINGS AGENCY	PA71870099	06/15/2017	\$14.72		06/15/2017		R&R-Invoice	Payroll Generated Invoice
00448	PENNSYLVANIA LIFE INSURANCE CO	PA71870137	06/15/2017	\$14.64		06/15/2017		R&R-Invoice	Payroll Generated Invoice
00523	AFLAC	PA71640047	06/09/2017	\$14.94		06/09/2017		R&R-Invoice	Payroll Generated Invoice
00523	AFLAC	PA71870215	06/15/2017	\$14.77		06/15/2017		R&R-Invoice	Payroll Generated Invoice
00523	AFLAC	PA71880046	06/16/2017	\$14.94		06/16/2017		R&R-Invoice	Payroll Generated Invoice
00530	AMERICAN GENERAL LIFE	PA71870325	06/15/2017	\$14.89		06/15/2017		R&R-Invoice	Payroll Generated Invoice
00653	AMERICAN-AMICABLE LIFE INSURAN	PA71870402	06/15/2017	\$15.00		06/15/2017		R&R-Invoice	Payroll Generated Invoice
00877	MASE/CWA	PA71640090	06/09/2017	\$14.12		06/09/2017		R&R-Invoice	Payroll Generated Invoice
00877	MASE/CWA	PA71880088	06/16/2017	\$14.12		06/16/2017		R&R-Invoice	Payroll Generated Invoice
06867	GENERAL FUND	PA71870643	06/15/2017	\$14.43		06/15/2017		R&R-Invoice	Payroll Generated Invoice
06867	GENERAL FUND	PA71870644	06/15/2017	\$15.00		06/15/2017		R&R-Invoice	Payroll Generated Invoice
60028	3P BENEFIT SOLUTIONS LLC	PA71870682	06/15/2017	\$15.00		06/15/2017		R&R-Invoice	Payroll Generated Invoice
65572	UNUM PROVIDENT LIFE & ACCIDENT	PA71870722	06/15/2017	\$14.65		06/15/2017		R&R-Invoice	Payroll Generated Invoice
66394	COMPBENEFITS	PA71870755	06/15/2017	\$14.44		06/15/2017		R&R-Invoice	Payroll Generated Invoice
66394	COMPBENEFITS	PA71870760	06/15/2017	\$14.42		06/15/2017		R&R-Invoice	Payroll Generated Invoice
66394	COMPBENEFITS	PA71870780	06/15/2017	\$14.42		06/15/2017		R&R-Invoice	Payroll Generated Invoice
66394	COMPBENEFITS	PA71870795	06/15/2017	\$14.42		06/15/2017		R&R-Invoice	Payroll Generated Invoice
66394	COMPBENEFITS	PA71870797	06/15/2017	\$14.42		06/15/2017		R&R-Invoice	Payroll Generated Invoice
66394	COMPBENEFITS	PA71870809	06/15/2017	\$14.42		06/15/2017		R&R-Invoice	Payroll Generated Invoice
66394	COMPBENEFITS	PA71870816	06/15/2017	\$14.42		06/15/2017		R&R-Invoice	Payroll Generated Invoice

AP757
 VENDOR PAYMENTS / FOR CLAIM DOCKET - 06/27/2017
 REPORT TITLE - AMOUNTS (DESCENDING) ALL TYPES
 Invoice Payments Under \$500

VEN#	VENDOR-NAME	INVOICE	INV-DATE	AMOUNT	AUTHORIZATION	DUE-DATE	REF-NUMBER	PAYMENT-TYPE	REMARKS
66394	COMPBENEFITS	PA71870855	06/15/2017	\$14.44		06/15/2017		R&R-Invoice	Payroll Generated Invoice
66394	COMPBENEFITS	PA71870865	06/15/2017	\$14.42		06/15/2017		R&R-Invoice	Payroll Generated Invoice
66394	COMPBENEFITS	PA71870870	06/15/2017	\$14.42		06/15/2017		R&R-Invoice	Payroll Generated Invoice
66394	COMPBENEFITS	PA71870873	06/15/2017	\$14.44		06/15/2017		R&R-Invoice	Payroll Generated Invoice
66394	COMPBENEFITS	PA71870891	06/15/2017	\$14.44		06/15/2017		R&R-Invoice	Payroll Generated Invoice
66394	COMPBENEFITS	PA71870894	06/15/2017	\$14.42		06/15/2017		R&R-Invoice	Payroll Generated Invoice
00432	H D CATCHINGS AGENCY	PA71640023	06/09/2017	\$13.79		06/09/2017		R&R-Invoice	Payroll Generated Invoice
00432	H D CATCHINGS AGENCY	PA71870101	06/15/2017	\$13.08		06/15/2017		R&R-Invoice	Payroll Generated Invoice
00432	H D CATCHINGS AGENCY	PA71880023	06/16/2017	\$13.79		06/16/2017		R&R-Invoice	Payroll Generated Invoice
00653	AMERICAN-AMICABLE LIFE INSURAN	PA718700384	06/15/2017	\$13.16		06/15/2017		R&R-Invoice	Payroll Generated Invoice
00657	COLONIAL LIFE & ACCIDENT CO.	PA718700449	06/15/2017	\$13.45		06/15/2017		R&R-Invoice	Payroll Generated Invoice
00657	COLONIAL LIFE & ACCIDENT CO.	PA718700454	06/15/2017	\$13.45		06/15/2017		R&R-Invoice	Payroll Generated Invoice
00765	AMERICAN HERITAGE LIFE INSURAN	PA71640086	06/09/2017	\$13.60		06/09/2017		R&R-Invoice	Payroll Generated Invoice
00765	AMERICAN HERITAGE LIFE INSURAN	PA71880084	06/16/2017	\$13.60		06/16/2017		R&R-Invoice	Payroll Generated Invoice
00877	MASE/CWA	PA71640098	06/09/2017	\$13.44		06/09/2017		R&R-Invoice	Payroll Generated Invoice
00877	MASE/CWA	PA71640100	06/09/2017	\$13.79		06/09/2017		R&R-Invoice	Payroll Generated Invoice
00877	MASE/CWA	PA71640106	06/09/2017	\$13.46		06/09/2017		R&R-Invoice	Payroll Generated Invoice
00877	MASE/CWA	PA71870547	06/15/2017	\$13.48		06/15/2017		R&R-Invoice	Payroll Generated Invoice
00877	MASE/CWA	PA71870580	06/15/2017	\$14.00		06/15/2017		R&R-Invoice	Payroll Generated Invoice
00877	MASE/CWA	PA71870583	06/15/2017	\$13.16		06/15/2017		R&R-Invoice	Payroll Generated Invoice
00877	MASE/CWA	PA71870598	06/15/2017	\$13.78		06/15/2017		R&R-Invoice	Payroll Generated Invoice
00877	MASE/CWA	PA71870601	06/15/2017	\$13.78		06/15/2017		R&R-Invoice	Payroll Generated Invoice
00877	MASE/CWA	PA71880096	06/16/2017	\$13.44		06/16/2017		R&R-Invoice	Payroll Generated Invoice
00877	MASE/CWA	PA71880098	06/16/2017	\$13.79		06/16/2017		R&R-Invoice	Payroll Generated Invoice
00877	MASE/CWA	PA71880104	06/16/2017	\$13.84		06/16/2017		R&R-Invoice	Payroll Generated Invoice
06867	GENERAL FUND	PA71870647	06/15/2017	\$13.84		06/15/2017		R&R-Invoice	Payroll Generated Invoice
00523	AFLAC	PA71870262	06/15/2017	\$12.24		06/15/2017		R&R-Invoice	Payroll Generated Invoice
00523	AFLAC	PA71870274	06/15/2017	\$12.42		06/15/2017		R&R-Invoice	Payroll Generated Invoice
00523	AFLAC	PA71870281	06/15/2017	\$12.24		06/15/2017		R&R-Invoice	Payroll Generated Invoice
00523	AFLAC	PA71870288	06/15/2017	\$12.42		06/15/2017		R&R-Invoice	Payroll Generated Invoice
00530	AMERICAN GENERAL LIFE	PA71870324	06/15/2017	\$12.62		06/15/2017		R&R-Invoice	Payroll Generated Invoice
00653	AMERICAN-AMICABLE LIFE INSURAN	PA71640065	06/09/2017	\$12.50		06/09/2017		R&R-Invoice	Payroll Generated Invoice
00653	AMERICAN-AMICABLE LIFE INSURAN	PA71880064	06/16/2017	\$12.50		06/16/2017		R&R-Invoice	Payroll Generated Invoice
00657	COLONIAL LIFE & ACCIDENT CO.	PA71870414	06/15/2017	\$12.18		06/15/2017		R&R-Invoice	Payroll Generated Invoice
00657	COLONIAL LIFE & ACCIDENT CO.	PA71870434	06/15/2017	\$12.28		06/15/2017		R&R-Invoice	Payroll Generated Invoice
00764	OCCIDENTAL LIFE INSURANCE CO	PA71870492	06/15/2017	\$12.22		06/15/2017		R&R-Invoice	Payroll Generated Invoice
00765	AMERICAN HERITAGE LIFE INSURAN	PA71870497	06/15/2017	\$12.14		06/15/2017		R&R-Invoice	Payroll Generated Invoice
00877	MASE/CWA	PA71870564	06/15/2017	\$12.58		06/15/2017		R&R-Invoice	Payroll Generated Invoice
00877	MASE/CWA	PA71870578	06/15/2017	\$12.03		06/15/2017		R&R-Invoice	Payroll Generated Invoice
00448	PENNSYLVANIA LIFE INSURANCE CO	PA71640026	06/09/2017	\$11.73		06/09/2017		R&R-Invoice	Payroll Generated Invoice
00448	PENNSYLVANIA LIFE INSURANCE CO	PA71880026	06/16/2017	\$11.73		06/16/2017		R&R-Invoice	Payroll Generated Invoice
00657	COLONIAL LIFE & ACCIDENT CO.	PA71870430	06/15/2017	\$11.38		06/15/2017		R&R-Invoice	Payroll Generated Invoice

AP757 VENDOR PAYMENTS / FOR CLAIM DOCKET - 06/27/2017
 REPORT TITLE - AMOUNTS (DESCENDING) ALL TYPES
 Invoice Payments Under \$500

VEN#	VENDOR-NAME	INVOICE	INV-DATE	AMOUNT	AUTHORIZATION	DUE-DATE	REF-NUMBER	PAYMENT-TYPE	REMARKS
00657	COLONIAL LIFE & ACCIDENT CO.	PAY1870448	06/15/2017	\$11.99		06/15/2017		R&R-Invoice	Payroll Generated Invoice
00765	AMERICAN HERITAGE LIFE INSURAN	PAY1870525	06/15/2017	\$11.52		06/15/2017		R&R-Invoice	Payroll Generated Invoice
00877	MASE/CWA	PAY1870566	06/15/2017	\$11.50		06/15/2017		R&R-Invoice	Payroll Generated Invoice
00877	MASE/CWA	PAY1870569	06/15/2017	\$11.50		06/15/2017		R&R-Invoice	Payroll Generated Invoice
00944	PRE-PAID LEGAL SERVICES INC	PAY1870618	06/15/2017	\$11.95		06/15/2017		R&R-Invoice	Payroll Generated Invoice
00944	PRE-PAID LEGAL SERVICES INC	PAY1870619	06/15/2017	\$11.95		06/15/2017		R&R-Invoice	Payroll Generated Invoice
00944	PRE-PAID LEGAL SERVICES INC	PAY1870627	06/15/2017	\$11.95		06/15/2017		R&R-Invoice	Payroll Generated Invoice
60028	3P BENEFIT SOLUTIONS LLC	PAY1870700	06/15/2017	\$11.04		06/15/2017		R&R-Invoice	Payroll Generated Invoice
65572	UNUM PROVIDENT LIFE & ACCIDENT	PAY1870731	06/15/2017	\$12.00		06/15/2017		R&R-Invoice	Payroll Generated Invoice
00415	LIFE OF ALABAMA	PAY1640006	06/09/2017	\$11.58		06/09/2017		R&R-Invoice	Payroll Generated Invoice
00415	LIFE OF ALABAMA	PAY1870035	06/15/2017	\$10.97		06/15/2017		R&R-Invoice	Payroll Generated Invoice
00415	LIFE OF ALABAMA	PAY1880006	06/16/2017	\$10.89		06/16/2017		R&R-Invoice	Payroll Generated Invoice
00432	H D CATCHINGS AGENCY	PAY1640016	06/09/2017	\$10.97		06/09/2017		R&R-Invoice	Payroll Generated Invoice
00432	H D CATCHINGS AGENCY	PAY1870091	06/15/2017	\$10.24		06/15/2017		R&R-Invoice	Payroll Generated Invoice
00432	H D CATCHINGS AGENCY	PAY1880016	06/16/2017	\$10.60		06/16/2017		R&R-Invoice	Payroll Generated Invoice
00523	AFLAC	PAY1640053	06/09/2017	\$10.24		06/09/2017		R&R-Invoice	Payroll Generated Invoice
00523	AFLAC	PAY1870239	06/15/2017	\$10.56		06/15/2017		R&R-Invoice	Payroll Generated Invoice
00523	AFLAC	PAY1870259	06/15/2017	\$10.11		06/15/2017		R&R-Invoice	Payroll Generated Invoice
00523	AFLAC	PAY1870263	06/15/2017	\$10.98		06/15/2017		R&R-Invoice	Payroll Generated Invoice
00523	AFLAC	PAY1880052	06/16/2017	\$10.57		06/16/2017		R&R-Invoice	Payroll Generated Invoice
00653	AMERICAN-AMICABLE LIFE INSURAN	PAY1870398	06/15/2017	\$10.56		06/15/2017		R&R-Invoice	Payroll Generated Invoice
00657	COLONIAL LIFE & ACCIDENT CO.	PAY1640070	06/09/2017	\$10.92		06/09/2017		R&R-Invoice	Payroll Generated Invoice
00657	COLONIAL LIFE & ACCIDENT CO.	PAY1870433	06/15/2017	\$10.28		06/15/2017		R&R-Invoice	Payroll Generated Invoice
00657	COLONIAL LIFE & ACCIDENT CO.	PAY1870435	06/15/2017	\$10.48		06/15/2017		R&R-Invoice	Payroll Generated Invoice
00657	COLONIAL LIFE & ACCIDENT CO.	PAY1870451	06/15/2017	\$10.86		06/15/2017		R&R-Invoice	Payroll Generated Invoice
00657	COLONIAL LIFE & ACCIDENT CO.	PAY1880069	06/16/2017	\$10.38		06/16/2017		R&R-Invoice	Payroll Generated Invoice
00765	AMERICAN HERITAGE LIFE INSURAN	PAY1640087	06/09/2017	\$10.28		06/09/2017		R&R-Invoice	Payroll Generated Invoice
00765	AMERICAN HERITAGE LIFE INSURAN	PAY1880085	06/16/2017	\$10.48		06/16/2017		R&R-Invoice	Payroll Generated Invoice
00877	MASE/CWA	PAY1870546	06/15/2017	\$10.48		06/15/2017		R&R-Invoice	Payroll Generated Invoice
00877	MASE/CWA	PAY1870549	06/15/2017	\$11.00		06/15/2017		R&R-Invoice	Payroll Generated Invoice
00877	MASE/CWA	PAY1870554	06/15/2017	\$10.29		06/15/2017		R&R-Invoice	Payroll Generated Invoice
00877	MASE/CWA	PAY1870567	06/15/2017	\$10.07		06/15/2017		R&R-Invoice	Payroll Generated Invoice
00877	MASE/CWA	PAY1870588	06/15/2017	\$10.07		06/15/2017		R&R-Invoice	Payroll Generated Invoice
00877	MASE/CWA	PAY1870589	06/15/2017	\$10.52		06/15/2017		R&R-Invoice	Payroll Generated Invoice
66394	COMPBENEFITS	PAY1870758	06/15/2017	\$11.00		06/15/2017		R&R-Invoice	Payroll Generated Invoice
66394	COMPBENEFITS	PAY1870762	06/15/2017	\$10.61		06/15/2017		R&R-Invoice	Payroll Generated Invoice
66394	COMPBENEFITS	PAY1870763	06/15/2017	\$10.83		06/15/2017		R&R-Invoice	Payroll Generated Invoice
66394	COMPBENEFITS	PAY1870769	06/15/2017	\$10.61		06/15/2017		R&R-Invoice	Payroll Generated Invoice
66394	COMPBENEFITS	PAY1870771	06/15/2017	\$10.61		06/15/2017		R&R-Invoice	Payroll Generated Invoice
66394	COMPBENEFITS	PAY1870781	06/15/2017	\$10.61		06/15/2017		R&R-Invoice	Payroll Generated Invoice
66394	COMPBENEFITS	PAY1870785	06/15/2017	\$10.61		06/15/2017		R&R-Invoice	Payroll Generated Invoice
66394	COMPBENEFITS	PAY1870787	06/15/2017	\$10.61		06/15/2017		R&R-Invoice	Payroll Generated Invoice
66394	COMPBENEFITS	PAY1870788	06/15/2017	\$10.61		06/15/2017		R&R-Invoice	Payroll Generated Invoice

AP757 VENDOR PAYMENTS / FOR CLAIM DOCKET - 06/27/2017
 REPORT TITLE - AMOUNTS (DESCENDING) ALL TYPES
 Invoice Payments Under \$500

VEN#	VENDOR-NAME	INVOICE	INV-DATE	AMOUNT	AUTHORIZATION	DUE-DATE	REF-NUMBER	PAYMENT-TYPE	REMARKS
66394	COMPBENEFITS	PA71870789	06/15/2017	\$10.61		06/15/2017		R&R-Invoice	Payroll Generated Invoice
66394	COMPBENEFITS	PA71870791	06/15/2017	\$10.61		06/15/2017		R&R-Invoice	Payroll Generated Invoice
66394	COMPBENEFITS	PA71870793	06/15/2017	\$10.61		06/15/2017		R&R-Invoice	Payroll Generated Invoice
66394	COMPBENEFITS	PA71870796	06/15/2017	\$10.83		06/15/2017		R&R-Invoice	Payroll Generated Invoice
66394	COMPBENEFITS	PA71870805	06/15/2017	\$10.61		06/15/2017		R&R-Invoice	Payroll Generated Invoice
66394	COMPBENEFITS	PA71870817	06/15/2017	\$10.61		06/15/2017		R&R-Invoice	Payroll Generated Invoice
66394	COMPBENEFITS	PA71870819	06/15/2017	\$10.61		06/15/2017		R&R-Invoice	Payroll Generated Invoice
66394	COMPBENEFITS	PA71870822	06/15/2017	\$10.61		06/15/2017		R&R-Invoice	Payroll Generated Invoice
66394	COMPBENEFITS	PA71870826	06/15/2017	\$10.83		06/15/2017		R&R-Invoice	Payroll Generated Invoice
66394	COMPBENEFITS	PA71870827	06/15/2017	\$10.61		06/15/2017		R&R-Invoice	Payroll Generated Invoice
66394	COMPBENEFITS	PA71870829	06/15/2017	\$10.61		06/15/2017		R&R-Invoice	Payroll Generated Invoice
66394	COMPBENEFITS	PA71870841	06/15/2017	\$10.83		06/15/2017		R&R-Invoice	Payroll Generated Invoice
66394	COMPBENEFITS	PA71870843	06/15/2017	\$10.61		06/15/2017		R&R-Invoice	Payroll Generated Invoice
66394	COMPBENEFITS	PA71870846	06/15/2017	\$10.61		06/15/2017		R&R-Invoice	Payroll Generated Invoice
66394	COMPBENEFITS	PA71870852	06/15/2017	\$10.61		06/15/2017		R&R-Invoice	Payroll Generated Invoice
66394	COMPBENEFITS	PA71870853	06/15/2017	\$10.83		06/15/2017		R&R-Invoice	Payroll Generated Invoice
66394	COMPBENEFITS	PA71870857	06/15/2017	\$10.61		06/15/2017		R&R-Invoice	Payroll Generated Invoice
66394	COMPBENEFITS	PA71870860	06/15/2017	\$10.61		06/15/2017		R&R-Invoice	Payroll Generated Invoice
66394	COMPBENEFITS	PA71870863	06/15/2017	\$10.61		06/15/2017		R&R-Invoice	Payroll Generated Invoice
66394	COMPBENEFITS	PA71870874	06/15/2017	\$10.61		06/15/2017		R&R-Invoice	Payroll Generated Invoice
66394	COMPBENEFITS	PA71870880	06/15/2017	\$10.61		06/15/2017		R&R-Invoice	Payroll Generated Invoice
66394	COMPBENEFITS	PA71870889	06/15/2017	\$10.61		06/15/2017		R&R-Invoice	Payroll Generated Invoice
66394	COMPBENEFITS	PA71870892	06/15/2017	\$10.61		06/15/2017		R&R-Invoice	Payroll Generated Invoice
66394	COMPBENEFITS	PA71870900	06/15/2017	\$10.83		06/15/2017		R&R-Invoice	Payroll Generated Invoice
66394	COMPBENEFITS	PA71870902	06/15/2017	\$10.61		06/15/2017		R&R-Invoice	Payroll Generated Invoice
66394	COMPBENEFITS	PA71870905	06/15/2017	\$10.61		06/15/2017		R&R-Invoice	Payroll Generated Invoice
66394	COMPBENEFITS	PA71870916	06/15/2017	\$10.61		06/15/2017		R&R-Invoice	Payroll Generated Invoice
70874	SOUTHERN STATES POLICE BENEVL	PA71870928	06/15/2017	\$10.85		06/15/2017		R&R-Invoice	Payroll Generated Invoice
00432	H D CATCHINGS AGENCY	PA71870059	06/15/2017	\$9.16		06/15/2017		R&R-Invoice	Payroll Generated Invoice
00529	POLICE HOSPITAL FUND	PA71870308	06/15/2017	\$9.24		06/15/2017		R&R-Invoice	Payroll Generated Invoice
00529	POLICE HOSPITAL FUND	PA71870310	06/15/2017	\$9.24		06/15/2017		R&R-Invoice	Payroll Generated Invoice
00531	JRA PARKING	PA71870328	06/15/2017	\$9.24		06/15/2017		R&R-Invoice	Payroll Generated Invoice
00531	JRA PARKING	PA71870331	06/15/2017	\$9.24		06/15/2017		R&R-Invoice	Payroll Generated Invoice
00531	JRA PARKING	PA71870334	06/15/2017	\$9.24		06/15/2017		R&R-Invoice	Payroll Generated Invoice
00531	JRA PARKING	PA71870337	06/15/2017	\$9.24		06/15/2017		R&R-Invoice	Payroll Generated Invoice
00531	JRA PARKING	PA71870340	06/15/2017	\$9.24		06/15/2017		R&R-Invoice	Payroll Generated Invoice
00531	JRA PARKING	PA71870342	06/15/2017	\$9.24		06/15/2017		R&R-Invoice	Payroll Generated Invoice
00531	JRA PARKING	PA71870345	06/15/2017	\$9.24		06/15/2017		R&R-Invoice	Payroll Generated Invoice
00531	JRA PARKING	PA71870347	06/15/2017	\$9.24		06/15/2017		R&R-Invoice	Payroll Generated Invoice
00531	JRA PARKING	PA71870351	06/15/2017	\$9.24		06/15/2017		R&R-Invoice	Payroll Generated Invoice
00531	JRA PARKING	PA71870352	06/15/2017	\$9.24		06/15/2017		R&R-Invoice	Payroll Generated Invoice
00531	JRA PARKING	PA71870353	06/15/2017	\$9.24		06/15/2017		R&R-Invoice	Payroll Generated Invoice
00531	JRA PARKING	PA71870355	06/15/2017	\$9.24		06/15/2017		R&R-Invoice	Payroll Generated Invoice

AP757

VENDOR PAYMENTS / FOR CLAIM DOCKET - 06/27/2017
 REPORT TITLE - AMOUNTS (DESCENDING) ALL TYPES

Invoice Payments Under \$500

VEN#	VENDOR-NAME	INVOICE	INV-DATE	AMOUNT	AUTHORIZATION	DUE-DATE	REF-NUMBER	PAYMENT-TYPE	REMARKS
00531	JRA PARKING	PA71870357	06/15/2017	\$9.24		06/15/2017		R&R-Invoice	Payroll Generated Invoice
00531	JRA PARKING	PA71870359	06/15/2017	\$9.24		06/15/2017		R&R-Invoice	Payroll Generated Invoice
00531	JRA PARKING	PA71870360	06/15/2017	\$9.24		06/15/2017		R&R-Invoice	Payroll Generated Invoice
00531	JRA PARKING	PA71870361	06/15/2017	\$9.24		06/15/2017		R&R-Invoice	Payroll Generated Invoice
00531	JRA PARKING	PA71870363	06/15/2017	\$9.24		06/15/2017		R&R-Invoice	Payroll Generated Invoice
00531	JRA PARKING	PA71870366	06/15/2017	\$9.24		06/15/2017		R&R-Invoice	Payroll Generated Invoice
00531	JRA PARKING	PA71870369	06/15/2017	\$9.24		06/15/2017		R&R-Invoice	Payroll Generated Invoice
00653	AMERICAN-AMICABLE LIFE INSURAN	PA71640067	06/09/2017	\$10.00		06/09/2017		R&R-Invoice	Payroll Generated Invoice
00653	AMERICAN-AMICABLE LIFE INSURAN	PA71880066	06/16/2017	\$10.00		06/16/2017		R&R-Invoice	Payroll Generated Invoice
00657	COLONIAL LIFE & ACCIDENT CO.	PA71870418	06/15/2017	\$9.35		06/15/2017		R&R-Invoice	Payroll Generated Invoice
00657	COLONIAL LIFE & ACCIDENT CO.	PA71870438	06/15/2017	\$9.76		06/15/2017		R&R-Invoice	Payroll Generated Invoice
00657	COLONIAL LIFE & ACCIDENT CO.	PA71870445	06/15/2017	\$9.26		06/15/2017		R&R-Invoice	Payroll Generated Invoice
00764	OCCIDENTAL LIFE INSURANCE CO	PA71640078	06/09/2017	\$9.54		06/09/2017		R&R-Invoice	Payroll Generated Invoice
00764	OCCIDENTAL LIFE INSURANCE CO	PA71870486	06/15/2017	\$9.74		06/15/2017		R&R-Invoice	Payroll Generated Invoice
00764	OCCIDENTAL LIFE INSURANCE CO	PA71880076	06/16/2017	\$9.54		06/16/2017		R&R-Invoice	Payroll Generated Invoice
00765	AMERICAN HERITAGE LIFE INSURAN	PA71870499	06/15/2017	\$10.00		06/15/2017		R&R-Invoice	Payroll Generated Invoice
00765	AMERICAN HERITAGE LIFE INSURAN	PA71870512	06/15/2017	\$9.44		06/15/2017		R&R-Invoice	Payroll Generated Invoice
00877	MASE/CWA	PA71870572	06/15/2017	\$9.64		06/15/2017		R&R-Invoice	Payroll Generated Invoice
60028	3P BENEFIT SOLUTIONS LLC	PA71870705	06/15/2017	\$10.00		06/15/2017		R&R-Invoice	Payroll Generated Invoice
60028	3P BENEFIT SOLUTIONS LLC	PA71870708	06/15/2017	\$10.00		06/15/2017		R&R-Invoice	Payroll Generated Invoice
00411	AMERICAN PUBLIC LIFE INS CO	PA71870004	06/15/2017	\$8.44		06/15/2017		R&R-Invoice	Payroll Generated Invoice
00411	AMERICAN PUBLIC LIFE INS CO	PA71870005	06/15/2017	\$8.73		06/15/2017		R&R-Invoice	Payroll Generated Invoice
00415	LIFE OF ALABAMA	PA71640003	06/09/2017	\$8.91		06/09/2017		R&R-Invoice	Payroll Generated Invoice
00415	LIFE OF ALABAMA	PA71880003	06/16/2017	\$8.91		06/16/2017		R&R-Invoice	Payroll Generated Invoice
00432	H D CATCHINGS AGENCY	PA71640019	06/09/2017	\$8.58		06/09/2017		R&R-Invoice	Payroll Generated Invoice
00432	H D CATCHINGS AGENCY	PA71870049	06/15/2017	\$8.67		06/15/2017		R&R-Invoice	Payroll Generated Invoice
00432	H D CATCHINGS AGENCY	PA71880019	06/16/2017	\$8.58		06/16/2017		R&R-Invoice	Payroll Generated Invoice
00448	PENNSYLVANIA LIFE INSURANCE CO	PA71870138	06/15/2017	\$8.11		06/15/2017		R&R-Invoice	Payroll Generated Invoice
00523	AFLAC	PA71640045	06/09/2017	\$8.52		06/09/2017		R&R-Invoice	Payroll Generated Invoice
00523	AFLAC	PA71880044	06/16/2017	\$8.52		06/16/2017		R&R-Invoice	Payroll Generated Invoice
00653	AMERICAN-AMICABLE LIFE INSURAN	PA71640066	06/09/2017	\$8.32		06/09/2017		R&R-Invoice	Payroll Generated Invoice
00653	AMERICAN-AMICABLE LIFE INSURAN	PA71880065	06/16/2017	\$8.32		06/16/2017		R&R-Invoice	Payroll Generated Invoice
00657	COLONIAL LIFE & ACCIDENT CO.	PA71870443	06/15/2017	\$8.08		06/15/2017		R&R-Invoice	Payroll Generated Invoice
00658	PROVIDENT INSURANCE	PA71870461	06/15/2017	\$8.91		06/15/2017		R&R-Invoice	Payroll Generated Invoice
00765	AMERICAN HERITAGE LIFE INSURAN	PA71870506	06/15/2017	\$8.36		06/15/2017		R&R-Invoice	Payroll Generated Invoice
00765	AMERICAN HERITAGE LIFE INSURAN	PA71870520	06/15/2017	\$8.76		06/15/2017		R&R-Invoice	Payroll Generated Invoice
00877	MASE/CWA	PA71640099	06/09/2017	\$8.96		06/09/2017		R&R-Invoice	Payroll Generated Invoice
00877	MASE/CWA	PA71640104	06/09/2017	\$8.96		06/09/2017		R&R-Invoice	Payroll Generated Invoice
00877	MASE/CWA	PA71870575	06/15/2017	\$8.95		06/15/2017		R&R-Invoice	Payroll Generated Invoice
00877	MASE/CWA	PA71880097	06/16/2017	\$8.96		06/16/2017		R&R-Invoice	Payroll Generated Invoice
00877	MASE/CWA	PA71880102	06/16/2017	\$8.96		06/16/2017		R&R-Invoice	Payroll Generated Invoice
00415	LIFE OF ALABAMA	PA71640002	06/09/2017	\$7.60		06/09/2017		R&R-Invoice	Payroll Generated Invoice
00415	LIFE OF ALABAMA	PA71640007	06/09/2017	\$7.60		06/09/2017		R&R-Invoice	Payroll Generated Invoice

AP757 VENDOR PAYMENTS / FOR CLAIM DOCKET - 06/27/2017
 REPORT TITLE - AMOUNTS (DESCENDING) ALL TYPES
 Invoice Payments Under \$500

VEN#	VENDOR-NAME	INVOICE	INV-DATE	AMOUNT	AUTHORIZATION	DUE-DATE	REF-NUMBER	PAYMENT-TYPE	REMARKS
00415	LIFE OF ALABAMA	PA71880002	06/16/2017	\$7.60		06/16/2017		R&R-Invoice	Payroll Generated Invoice
00415	LIFE OF ALABAMA	PA71880007	06/16/2017	\$7.60		06/16/2017		R&R-Invoice	Payroll Generated Invoice
00432	H D CATCHINGS AGENCY	PA71640020	06/09/2017	\$7.13		06/09/2017		R&R-Invoice	Payroll Generated Invoice
00432	H D CATCHINGS AGENCY	PA71880020	06/16/2017	\$7.13		06/16/2017		R&R-Invoice	Payroll Generated Invoice
00523	AFLAC	PA71640051	06/09/2017	\$7.95		06/09/2017		R&R-Invoice	Payroll Generated Invoice
00523	AFLAC	PA71880050	06/16/2017	\$7.95		06/16/2017		R&R-Invoice	Payroll Generated Invoice
00530	AMERICAN GENERAL LIFE	PA71640059	06/09/2017	\$7.78		06/09/2017		R&R-Invoice	Payroll Generated Invoice
00530	AMERICAN GENERAL LIFE	PA71880058	06/16/2017	\$7.78		06/16/2017		R&R-Invoice	Payroll Generated Invoice
00653	AMERICAN-AMICABLE LIFE INSURAN	PA71640062	06/09/2017	\$7.50		06/09/2017		R&R-Invoice	Payroll Generated Invoice
00653	AMERICAN-AMICABLE LIFE INSURAN	PA71880061	06/16/2017	\$7.50		06/16/2017		R&R-Invoice	Payroll Generated Invoice
00657	COLONIAL LIFE & ACCIDENT CO.	PA71640071	06/09/2017	\$7.27		06/09/2017		R&R-Invoice	Payroll Generated Invoice
00657	COLONIAL LIFE & ACCIDENT CO.	PA71880070	06/16/2017	\$7.27		06/16/2017		R&R-Invoice	Payroll Generated Invoice
00765	AMERICAN HERITAGE LIFE INSURAN	PA71640085	06/09/2017	\$7.57		06/09/2017		R&R-Invoice	Payroll Generated Invoice
00765	AMERICAN HERITAGE LIFE INSURAN	PA71880083	06/16/2017	\$7.57		06/16/2017		R&R-Invoice	Payroll Generated Invoice
00944	PRE-PAID LEGAL SERVICES INC	PA71870620	06/15/2017	\$7.36		06/15/2017		R&R-Invoice	Payroll Generated Invoice
00944	PRE-PAID LEGAL SERVICES INC	PA71870624	06/15/2017	\$7.36		06/15/2017		R&R-Invoice	Payroll Generated Invoice
00944	PRE-PAID LEGAL SERVICES INC	PA71870625	06/15/2017	\$7.36		06/15/2017		R&R-Invoice	Payroll Generated Invoice
00944	PRE-PAID LEGAL SERVICES INC	PA71870626	06/15/2017	\$7.36		06/15/2017		R&R-Invoice	Payroll Generated Invoice
00944	PRE-PAID LEGAL SERVICES INC	PA71870628	06/15/2017	\$7.36		06/15/2017		R&R-Invoice	Payroll Generated Invoice
00944	PRE-PAID LEGAL SERVICES INC	PA71870648	06/15/2017	\$7.50		06/15/2017		R&R-Invoice	Payroll Generated Invoice
00867	GENERAL FUND	PA71870649	06/15/2017	\$7.50		06/15/2017		R&R-Invoice	Payroll Generated Invoice
00867	GENERAL FUND	PA71870652	06/15/2017	\$7.50		06/15/2017		R&R-Invoice	Payroll Generated Invoice
00867	GENERAL FUND	PA71870655	06/15/2017	\$7.50		06/15/2017		R&R-Invoice	Payroll Generated Invoice
00867	GENERAL FUND	PA71870656	06/15/2017	\$7.50		06/15/2017		R&R-Invoice	Payroll Generated Invoice
00867	GENERAL FUND	PA71870657	06/15/2017	\$7.50		06/15/2017		R&R-Invoice	Payroll Generated Invoice
00867	GENERAL FUND	PA71870659	06/15/2017	\$7.50		06/15/2017		R&R-Invoice	Payroll Generated Invoice
00867	GENERAL FUND	PA71870665	06/09/2017	\$7.24		06/09/2017		R&R-Invoice	Payroll Generated Invoice
00867	GENERAL FUND	PA71640121	06/09/2017	\$7.24		06/09/2017		R&R-Invoice	Payroll Generated Invoice
66394	COMPBENEFITS	PA71640131	06/09/2017	\$7.22		06/09/2017		R&R-Invoice	Payroll Generated Invoice
66394	COMPBENEFITS	PA71870753	06/15/2017	\$7.22		06/15/2017		R&R-Invoice	Payroll Generated Invoice
66394	COMPBENEFITS	PA71870754	06/15/2017	\$7.21		06/15/2017		R&R-Invoice	Payroll Generated Invoice
66394	COMPBENEFITS	PA71870756	06/15/2017	\$7.22		06/15/2017		R&R-Invoice	Payroll Generated Invoice
66394	COMPBENEFITS	PA71870765	06/15/2017	\$7.21		06/15/2017		R&R-Invoice	Payroll Generated Invoice
66394	COMPBENEFITS	PA71870766	06/15/2017	\$7.22		06/15/2017		R&R-Invoice	Payroll Generated Invoice
66394	COMPBENEFITS	PA71870767	06/15/2017	\$7.21		06/15/2017		R&R-Invoice	Payroll Generated Invoice
66394	COMPBENEFITS	PA71870774	06/15/2017	\$7.21		06/15/2017		R&R-Invoice	Payroll Generated Invoice
66394	COMPBENEFITS	PA71870776	06/15/2017	\$7.21		06/15/2017		R&R-Invoice	Payroll Generated Invoice
66394	COMPBENEFITS	PA71870784	06/15/2017	\$7.21		06/15/2017		R&R-Invoice	Payroll Generated Invoice
66394	COMPBENEFITS	PA71870794	06/15/2017	\$7.22		06/15/2017		R&R-Invoice	Payroll Generated Invoice
66394	COMPBENEFITS	PA71870798	06/15/2017	\$7.22		06/15/2017		R&R-Invoice	Payroll Generated Invoice
66394	COMPBENEFITS	PA71870804	06/15/2017	\$7.21		06/15/2017		R&R-Invoice	Payroll Generated Invoice
66394	COMPBENEFITS	PA71870807	06/15/2017	\$7.21		06/15/2017		R&R-Invoice	Payroll Generated Invoice
66394	COMPBENEFITS	PA71870808	06/15/2017	\$7.22		06/15/2017		R&R-Invoice	Payroll Generated Invoice
66394	COMPBENEFITS	PA71870828	06/15/2017	\$7.21		06/15/2017		R&R-Invoice	Payroll Generated Invoice

VENDOR PAYMENTS / FOR CLAIM DOCKET - 06/27/2017
 REPORT TITLE - AMOUNTS (DESCENDING) ALL TYPES
 Invoice Payments Under \$500

AP757

VEN#	VENDOR-NAME	INVOICE	INV-DATE	AMOUNT	AUTHORIZATION	DUE-DATE	REF-NUMBER	PAYMENT-TYPE	REMARKS
66394	COMPBENEFITS	PA71870831	06/15/2017	\$7.21		06/15/2017		R&R-Invoice	Payroll Generated Invoice
66394	COMPBENEFITS	PA71870832	06/15/2017	\$7.21		06/15/2017		R&R-Invoice	Payroll Generated Invoice
66394	COMPBENEFITS	PA71870833	06/15/2017	\$7.21		06/15/2017		R&R-Invoice	Payroll Generated Invoice
66394	COMPBENEFITS	PA71870834	06/15/2017	\$7.21		06/15/2017		R&R-Invoice	Payroll Generated Invoice
66394	COMPBENEFITS	PA71870835	06/15/2017	\$7.21		06/15/2017		R&R-Invoice	Payroll Generated Invoice
66394	COMPBENEFITS	PA71870836	06/15/2017	\$7.21		06/15/2017		R&R-Invoice	Payroll Generated Invoice
66394	COMPBENEFITS	PA71870839	06/15/2017	\$7.21		06/15/2017		R&R-Invoice	Payroll Generated Invoice
66394	COMPBENEFITS	PA71870842	06/15/2017	\$7.21		06/15/2017		R&R-Invoice	Payroll Generated Invoice
66394	COMPBENEFITS	PA71870847	06/15/2017	\$7.22		06/15/2017		R&R-Invoice	Payroll Generated Invoice
66394	COMPBENEFITS	PA71870848	06/15/2017	\$7.21		06/15/2017		R&R-Invoice	Payroll Generated Invoice
66394	COMPBENEFITS	PA71870854	06/15/2017	\$7.21		06/15/2017		R&R-Invoice	Payroll Generated Invoice
66394	COMPBENEFITS	PA71870858	06/15/2017	\$7.22		06/15/2017		R&R-Invoice	Payroll Generated Invoice
66394	COMPBENEFITS	PA71870862	06/15/2017	\$7.22		06/15/2017		R&R-Invoice	Payroll Generated Invoice
66394	COMPBENEFITS	PA71870866	06/15/2017	\$7.22		06/15/2017		R&R-Invoice	Payroll Generated Invoice
66394	COMPBENEFITS	PA71870868	06/15/2017	\$7.21		06/15/2017		R&R-Invoice	Payroll Generated Invoice
66394	COMPBENEFITS	PA71870869	06/15/2017	\$7.22		06/15/2017		R&R-Invoice	Payroll Generated Invoice
66394	COMPBENEFITS	PA71870877	06/15/2017	\$7.21		06/15/2017		R&R-Invoice	Payroll Generated Invoice
66394	COMPBENEFITS	PA71870879	06/15/2017	\$7.21		06/15/2017		R&R-Invoice	Payroll Generated Invoice
66394	COMPBENEFITS	PA71870883	06/15/2017	\$7.21		06/15/2017		R&R-Invoice	Payroll Generated Invoice
66394	COMPBENEFITS	PA71870886	06/15/2017	\$7.21		06/15/2017		R&R-Invoice	Payroll Generated Invoice
66394	COMPBENEFITS	PA71870888	06/15/2017	\$7.21		06/15/2017		R&R-Invoice	Payroll Generated Invoice
66394	COMPBENEFITS	PA71870895	06/15/2017	\$7.22		06/15/2017		R&R-Invoice	Payroll Generated Invoice
66394	COMPBENEFITS	PA71870896	06/15/2017	\$7.21		06/15/2017		R&R-Invoice	Payroll Generated Invoice
66394	COMPBENEFITS	PA71870899	06/15/2017	\$7.21		06/15/2017		R&R-Invoice	Payroll Generated Invoice
66394	COMPBENEFITS	PA71870901	06/15/2017	\$7.21		06/15/2017		R&R-Invoice	Payroll Generated Invoice
66394	COMPBENEFITS	PA71870903	06/15/2017	\$7.21		06/15/2017		R&R-Invoice	Payroll Generated Invoice
66394	COMPBENEFITS	PA71870904	06/15/2017	\$7.22		06/15/2017		R&R-Invoice	Payroll Generated Invoice
66394	COMPBENEFITS	PA71870906	06/15/2017	\$7.22		06/15/2017		R&R-Invoice	Payroll Generated Invoice
66394	COMPBENEFITS	PA71870907	06/15/2017	\$7.21		06/15/2017		R&R-Invoice	Payroll Generated Invoice
66394	COMPBENEFITS	PA71870908	06/15/2017	\$7.22		06/15/2017		R&R-Invoice	Payroll Generated Invoice
66394	COMPBENEFITS	PA71870911	06/15/2017	\$7.21		06/15/2017		R&R-Invoice	Payroll Generated Invoice
66394	COMPBENEFITS	PA71870917	06/15/2017	\$7.21		06/15/2017		R&R-Invoice	Payroll Generated Invoice
66394	COMPBENEFITS	PA71880119	06/16/2017	\$7.24		06/16/2017		R&R-Invoice	Payroll Generated Invoice
66394	COMPBENEFITS	PA71880129	06/16/2017	\$7.22		06/16/2017		R&R-Invoice	Payroll Generated Invoice
00411	AMERICAN PUBLIC LIFE INS CO	PA71870006	06/15/2017	\$6.92		06/15/2017		R&R-Invoice	Payroll Generated Invoice
00432	H D CATCHINGS AGENCY	PA71870051	06/15/2017	\$6.54		06/15/2017		R&R-Invoice	Payroll Generated Invoice
00432	H D CATCHINGS AGENCY	PA71870089	06/15/2017	\$6.01		06/15/2017		R&R-Invoice	Payroll Generated Invoice
00478	UNITED WAY	PA71870162	06/15/2017	\$6.16		06/15/2017		R&R-Invoice	Payroll Generated Invoice
00523	AFLAC	PA71640049	06/09/2017	\$6.99		06/09/2017		R&R-Invoice	Payroll Generated Invoice
00523	AFLAC	PA71640050	06/09/2017	\$6.21		06/09/2017		R&R-Invoice	Payroll Generated Invoice
00523	AFLAC	PA71640052	06/09/2017	\$6.21		06/09/2017		R&R-Invoice	Payroll Generated Invoice
00523	AFLAC	PA71880048	06/16/2017	\$6.99		06/16/2017		R&R-Invoice	Payroll Generated Invoice
00523	AFLAC	PA71880049	06/16/2017	\$6.21		06/16/2017		R&R-Invoice	Payroll Generated Invoice

VENDOR PAYMENTS / FOR CLAIM DOCKET - 06/27/2017
REPORT TITLE - AMOUNTS (DESCENDING) ALL TYPES
Invoice Payments Under \$500

VEN#	VENDOR-NAME	INVOICE	INV-DATE	AMOUNT	AUTHORIZATION	DUE-DATE	REF-NUMBER	PAYMENT-TYPE	REMARKS
00523	AFLAC	PA71880051	06/16/2017	\$6.21		06/16/2017		R&R-Invoice	Payroll Generated Invoice
00658	PROVIDENT INSURANCE	PA71870460	06/15/2017	\$6.53		06/15/2017		R&R-Invoice	Payroll Generated Invoice
06867	GENERAL FUND	PA71870654	06/15/2017	\$6.92		06/15/2017		R&R-Invoice	Payroll Generated Invoice
66136	STATE DISBURSEMENT UNIT	PA71870750	06/15/2017	\$6.46		06/15/2017		R&R-Invoice	Payroll Generated Invoice
00445	J ALLEN SANDIFER AGENCY	PA71870125	06/15/2017	\$6.00		06/15/2017		R&R-Invoice	Payroll Generated Invoice
00478	UNITED WAY	PA71870166	06/15/2017	\$6.00		06/15/2017		R&R-Invoice	Payroll Generated Invoice
00657	COLONIAL LIFE & ACCIDENT CO.	PA71640068	06/09/2017	\$5.07		06/09/2017		R&R-Invoice	Payroll Generated Invoice
00657	COLONIAL LIFE & ACCIDENT CO.	PA71870440	06/15/2017	\$5.06		06/15/2017		R&R-Invoice	Payroll Generated Invoice
00657	COLONIAL LIFE & ACCIDENT CO.	PA71880067	06/16/2017	\$5.07		06/16/2017		R&R-Invoice	Payroll Generated Invoice
00658	PROVIDENT INSURANCE	PA71870464	06/15/2017	\$5.72		06/15/2017		R&R-Invoice	Payroll Generated Invoice
66394	COMPBENEFITS	PA71640123	06/09/2017	\$5.30		06/09/2017		R&R-Invoice	Payroll Generated Invoice
66394	COMPBENEFITS	PA71640134	06/09/2017	\$5.43		06/09/2017		R&R-Invoice	Payroll Generated Invoice
66394	COMPBENEFITS	PA71870875	06/15/2017	\$5.30		06/15/2017		R&R-Invoice	Payroll Generated Invoice
66394	COMPBENEFITS	PA71880121	06/16/2017	\$5.30		06/16/2017		R&R-Invoice	Payroll Generated Invoice
66394	COMPBENEFITS	PA71880132	06/16/2017	\$5.43		06/16/2017		R&R-Invoice	Payroll Generated Invoice
70874	SOUTHERN STATES POLICE BENEVL	PA71640137	06/09/2017	\$5.42		06/09/2017		R&R-Invoice	Payroll Generated Invoice
70874	SOUTHERN STATES POLICE BENEVL	PA71880135	06/16/2017	\$5.42		06/16/2017		R&R-Invoice	Payroll Generated Invoice
00432	H D CATCHINGS AGENCY	PA71870056	06/15/2017	\$4.32		06/15/2017		R&R-Invoice	Payroll Generated Invoice
00432	H D CATCHINGS AGENCY	PA71870069	06/15/2017	\$4.61		06/15/2017		R&R-Invoice	Payroll Generated Invoice
00432	H D CATCHINGS AGENCY	PA71870092	06/15/2017	\$4.32		06/15/2017		R&R-Invoice	Payroll Generated Invoice
00432	H D CATCHINGS AGENCY	PA71880017	06/16/2017	\$4.58		06/16/2017		R&R-Invoice	Payroll Generated Invoice
00529	POLICE HOSPITAL FUND	PA71640057	06/09/2017	\$4.62		06/09/2017		R&R-Invoice	Payroll Generated Invoice
00529	POLICE HOSPITAL FUND	PA71870306	06/15/2017	\$4.62		06/15/2017		R&R-Invoice	Payroll Generated Invoice
00529	POLICE HOSPITAL FUND	PA71870312	06/15/2017	\$4.62		06/15/2017		R&R-Invoice	Payroll Generated Invoice
00529	POLICE HOSPITAL FUND	PA71870314	06/15/2017	\$4.62		06/15/2017		R&R-Invoice	Payroll Generated Invoice
00529	POLICE HOSPITAL FUND	PA71870318	06/15/2017	\$4.62		06/15/2017		R&R-Invoice	Payroll Generated Invoice
00529	POLICE HOSPITAL FUND	PA71880056	06/16/2017	\$4.62		06/16/2017		R&R-Invoice	Payroll Generated Invoice
00530	AMERICAN GENERAL LIFE	PA71640060	06/09/2017	\$4.49		06/09/2017		R&R-Invoice	Payroll Generated Invoice
00530	AMERICAN GENERAL LIFE	PA71880059	06/16/2017	\$4.49		06/16/2017		R&R-Invoice	Payroll Generated Invoice
00657	COLONIAL LIFE & ACCIDENT CO.	PA71640069	06/09/2017	\$4.45		06/09/2017		R&R-Invoice	Payroll Generated Invoice
00657	COLONIAL LIFE & ACCIDENT CO.	PA71870416	06/15/2017	\$4.50		06/15/2017		R&R-Invoice	Payroll Generated Invoice
00657	COLONIAL LIFE & ACCIDENT CO.	PA71880068	06/16/2017	\$4.45		06/16/2017		R&R-Invoice	Payroll Generated Invoice
00658	PROVIDENT INSURANCE	PA71640074	06/09/2017	\$4.59		06/09/2017		R&R-Invoice	Payroll Generated Invoice
00658	PROVIDENT INSURANCE	PA71880073	06/16/2017	\$4.59		06/16/2017		R&R-Invoice	Payroll Generated Invoice
00877	MASE/CWA	PA71640089	06/09/2017	\$4.48		06/09/2017		R&R-Invoice	Payroll Generated Invoice
00877	MASE/CWA	PA71640091	06/09/2017	\$4.61		06/09/2017		R&R-Invoice	Payroll Generated Invoice
00877	MASE/CWA	PA71640093	06/09/2017	\$4.48		06/09/2017		R&R-Invoice	Payroll Generated Invoice
00877	MASE/CWA	PA71640094	06/09/2017	\$4.48		06/09/2017		R&R-Invoice	Payroll Generated Invoice
00877	MASE/CWA	PA71640096	06/09/2017	\$4.48		06/09/2017		R&R-Invoice	Payroll Generated Invoice
00877	MASE/CWA	PA71640097	06/09/2017	\$4.48		06/09/2017		R&R-Invoice	Payroll Generated Invoice
00877	MASE/CWA	PA71640105	06/09/2017	\$4.50		06/09/2017		R&R-Invoice	Payroll Generated Invoice
00877	MASE/CWA	PA71880087	06/16/2017	\$4.48		06/16/2017		R&R-Invoice	Payroll Generated Invoice

AP757

VENDOR PAYMENTS / FOR CLAIM DOCKET - 06/27/2017
 REPORT TITLE - AMOUNTS (DESCENDING) ALL TYPES
 Invoice Payments Under \$500

VEN#	VENDOR-NAME	INVOICE	INV-DATE	AMOUNT	AUTHORIZATION	DUE-DATE	REF-NUMBER	PAYMENT-TYPE	REMARKS
00877	MASE/CWA	PA71880089	06/16/2017	\$4.61		06/16/2017		R&R-Invoice	Payroll Generated Invoice
00877	MASE/CWA	PA71880091	06/16/2017	\$4.48		06/16/2017		R&R-Invoice	Payroll Generated Invoice
00877	MASE/CWA	PA71880092	06/16/2017	\$4.48		06/16/2017		R&R-Invoice	Payroll Generated Invoice
00877	MASE/CWA	PA71880094	06/16/2017	\$4.48		06/16/2017		R&R-Invoice	Payroll Generated Invoice
00877	MASE/CWA	PA71880095	06/16/2017	\$4.48		06/16/2017		R&R-Invoice	Payroll Generated Invoice
00877	MASE/CWA	PA71880103	06/16/2017	\$4.50		06/16/2017		R&R-Invoice	Payroll Generated Invoice
65572	UNUM PROVIDENT LIFE & ACCIDENT	PA71640113	06/09/2017	\$4.59		06/09/2017		R&R-Invoice	Payroll Generated Invoice
65572	UNUM PROVIDENT LIFE & ACCIDENT	PA71640115	06/09/2017	\$4.59		06/09/2017		R&R-Invoice	Payroll Generated Invoice
65572	UNUM PROVIDENT LIFE & ACCIDENT	PA71640116	06/09/2017	\$4.09		06/09/2017		R&R-Invoice	Payroll Generated Invoice
65572	UNUM PROVIDENT LIFE & ACCIDENT	PA71880111	06/16/2017	\$4.59		06/16/2017		R&R-Invoice	Payroll Generated Invoice
65572	UNUM PROVIDENT LIFE & ACCIDENT	PA71880113	06/16/2017	\$4.59		06/16/2017		R&R-Invoice	Payroll Generated Invoice
65572	UNUM PROVIDENT LIFE & ACCIDENT	PA71880114	06/16/2017	\$4.09		06/16/2017		R&R-Invoice	Payroll Generated Invoice
00432	H D CATCHINGS AGENCY	PA71640022	06/09/2017	\$4.00		06/09/2017		R&R-Invoice	Payroll Generated Invoice
00432	H D CATCHINGS AGENCY	PA71880022	06/16/2017	\$4.00		06/16/2017		R&R-Invoice	Payroll Generated Invoice
00478	UNITED WAY	PA71640029	06/09/2017	\$3.16		06/09/2017		R&R-Invoice	Payroll Generated Invoice
00478	UNITED WAY	PA71880029	06/16/2017	\$3.16		06/16/2017		R&R-Invoice	Payroll Generated Invoice
00944	PRE-PAID LEGAL SERVICES INC	PA71640108	06/09/2017	\$3.68		06/09/2017		R&R-Invoice	Payroll Generated Invoice
00944	PRE-PAID LEGAL SERVICES INC	PA71640109	06/09/2017	\$3.68		06/09/2017		R&R-Invoice	Payroll Generated Invoice
00944	PRE-PAID LEGAL SERVICES INC	PA71640110	06/09/2017	\$3.68		06/09/2017		R&R-Invoice	Payroll Generated Invoice
00944	PRE-PAID LEGAL SERVICES INC	PA71880106	06/16/2017	\$3.68		06/16/2017		R&R-Invoice	Payroll Generated Invoice
00944	PRE-PAID LEGAL SERVICES INC	PA71880107	06/16/2017	\$3.68		06/16/2017		R&R-Invoice	Payroll Generated Invoice
00944	PRE-PAID LEGAL SERVICES INC	PA71880108	06/16/2017	\$3.68		06/16/2017		R&R-Invoice	Payroll Generated Invoice
66394	COMPBENEFITS	PA71640118	06/09/2017	\$3.62		06/09/2017		R&R-Invoice	Payroll Generated Invoice
66394	COMPBENEFITS	PA71640120	06/09/2017	\$3.61		06/09/2017		R&R-Invoice	Payroll Generated Invoice
66394	COMPBENEFITS	PA71640122	06/09/2017	\$3.61		06/09/2017		R&R-Invoice	Payroll Generated Invoice
66394	COMPBENEFITS	PA71640124	06/09/2017	\$3.62		06/09/2017		R&R-Invoice	Payroll Generated Invoice
66394	COMPBENEFITS	PA71640132	06/09/2017	\$3.62		06/09/2017		R&R-Invoice	Payroll Generated Invoice
66394	COMPBENEFITS	PA71640136	06/09/2017	\$3.61		06/09/2017		R&R-Invoice	Payroll Generated Invoice
66394	COMPBENEFITS	PA71870752	06/15/2017	\$3.61		06/15/2017		R&R-Invoice	Payroll Generated Invoice
66394	COMPBENEFITS	PA71870757	06/15/2017	\$3.61		06/15/2017		R&R-Invoice	Payroll Generated Invoice
66394	COMPBENEFITS	PA71870764	06/15/2017	\$3.61		06/15/2017		R&R-Invoice	Payroll Generated Invoice
66394	COMPBENEFITS	PA71870768	06/15/2017	\$3.61		06/15/2017		R&R-Invoice	Payroll Generated Invoice
66394	COMPBENEFITS	PA71870772	06/15/2017	\$3.61		06/15/2017		R&R-Invoice	Payroll Generated Invoice
66394	COMPBENEFITS	PA71870773	06/15/2017	\$3.61		06/15/2017		R&R-Invoice	Payroll Generated Invoice
66394	COMPBENEFITS	PA71870775	06/15/2017	\$3.61		06/15/2017		R&R-Invoice	Payroll Generated Invoice
66394	COMPBENEFITS	PA71870778	06/15/2017	\$3.61		06/15/2017		R&R-Invoice	Payroll Generated Invoice
66394	COMPBENEFITS	PA71870779	06/15/2017	\$3.61		06/15/2017		R&R-Invoice	Payroll Generated Invoice
66394	COMPBENEFITS	PA71870786	06/15/2017	\$3.61		06/15/2017		R&R-Invoice	Payroll Generated Invoice
66394	COMPBENEFITS	PA71870790	06/15/2017	\$3.61		06/15/2017		R&R-Invoice	Payroll Generated Invoice
66394	COMPBENEFITS	PA71870792	06/15/2017	\$3.61		06/15/2017		R&R-Invoice	Payroll Generated Invoice
66394	COMPBENEFITS	PA71870799	06/15/2017	\$3.61		06/15/2017		R&R-Invoice	Payroll Generated Invoice
66394	COMPBENEFITS	PA71870806	06/15/2017	\$3.61		06/15/2017		R&R-Invoice	Payroll Generated Invoice
66394	COMPBENEFITS	PA71870815	06/15/2017	\$3.61		06/15/2017		R&R-Invoice	Payroll Generated Invoice

AP757

VENDOR PAYMENTS / FOR CLAIM DOCKET - 06/27/2017
 REPORT TITLE - AMOUNTS (DESCENDING) ALL TYPES
 Invoice Payments Under \$500

VEN#	VENDOR-NAME	INVOICE	INV-DATE	AMOUNT	AUTHORIZATION	DUE-DATE	REF-NUMBER	PAYMENT-TYPE	REMARKS
66394	COMPBENEFITS	PA71870818	06/15/2017	\$3.61		06/15/2017		R&R-Invoice	Payroll Generated Invoice
66394	COMPBENEFITS	PA71870837	06/15/2017	\$3.61		06/15/2017		R&R-Invoice	Payroll Generated Invoice
66394	COMPBENEFITS	PA71870838	06/15/2017	\$3.61		06/15/2017		R&R-Invoice	Payroll Generated Invoice
66394	COMPBENEFITS	PA71870840	06/15/2017	\$3.61		06/15/2017		R&R-Invoice	Payroll Generated Invoice
66394	COMPBENEFITS	PA71870844	06/15/2017	\$3.61		06/15/2017		R&R-Invoice	Payroll Generated Invoice
66394	COMPBENEFITS	PA71870845	06/15/2017	\$3.61		06/15/2017		R&R-Invoice	Payroll Generated Invoice
66394	COMPBENEFITS	PA71870861	06/15/2017	\$3.61		06/15/2017		R&R-Invoice	Payroll Generated Invoice
66394	COMPBENEFITS	PA71870864	06/15/2017	\$3.61		06/15/2017		R&R-Invoice	Payroll Generated Invoice
66394	COMPBENEFITS	PA71870867	06/15/2017	\$3.61		06/15/2017		R&R-Invoice	Payroll Generated Invoice
66394	COMPBENEFITS	PA71870871	06/15/2017	\$3.61		06/15/2017		R&R-Invoice	Payroll Generated Invoice
66394	COMPBENEFITS	PA71870872	06/15/2017	\$3.61		06/15/2017		R&R-Invoice	Payroll Generated Invoice
66394	COMPBENEFITS	PA71870876	06/15/2017	\$3.61		06/15/2017		R&R-Invoice	Payroll Generated Invoice
66394	COMPBENEFITS	PA71870878	06/15/2017	\$3.61		06/15/2017		R&R-Invoice	Payroll Generated Invoice
66394	COMPBENEFITS	PA71870881	06/15/2017	\$3.61		06/15/2017		R&R-Invoice	Payroll Generated Invoice
66394	COMPBENEFITS	PA71870885	06/15/2017	\$3.61		06/15/2017		R&R-Invoice	Payroll Generated Invoice
66394	COMPBENEFITS	PA71870887	06/15/2017	\$3.61		06/15/2017		R&R-Invoice	Payroll Generated Invoice
66394	COMPBENEFITS	PA71870890	06/15/2017	\$3.61		06/15/2017		R&R-Invoice	Payroll Generated Invoice
66394	COMPBENEFITS	PA71870893	06/15/2017	\$3.61		06/15/2017		R&R-Invoice	Payroll Generated Invoice
66394	COMPBENEFITS	PA71870897	06/15/2017	\$3.61		06/15/2017		R&R-Invoice	Payroll Generated Invoice
66394	COMPBENEFITS	PA71870898	06/15/2017	\$3.61		06/15/2017		R&R-Invoice	Payroll Generated Invoice
66394	COMPBENEFITS	PA71870912	06/15/2017	\$3.61		06/15/2017		R&R-Invoice	Payroll Generated Invoice
66394	COMPBENEFITS	PA71870913	06/15/2017	\$3.61		06/15/2017		R&R-Invoice	Payroll Generated Invoice
66394	COMPBENEFITS	PA71870915	06/15/2017	\$3.61		06/15/2017		R&R-Invoice	Payroll Generated Invoice
66394	COMPBENEFITS	PA71870918	06/15/2017	\$3.61		06/15/2017		R&R-Invoice	Payroll Generated Invoice
66394	COMPBENEFITS	PA71880116	06/16/2017	\$3.62		06/16/2017		R&R-Invoice	Payroll Generated Invoice
66394	COMPBENEFITS	PA71880118	06/16/2017	\$3.61		06/16/2017		R&R-Invoice	Payroll Generated Invoice
66394	COMPBENEFITS	PA71880120	06/16/2017	\$3.61		06/16/2017		R&R-Invoice	Payroll Generated Invoice
66394	COMPBENEFITS	PA71880122	06/16/2017	\$3.62		06/16/2017		R&R-Invoice	Payroll Generated Invoice
66394	COMPBENEFITS	PA71880130	06/16/2017	\$3.62		06/16/2017		R&R-Invoice	Payroll Generated Invoice
66394	COMPBENEFITS	PA71880134	06/16/2017	\$3.61		06/16/2017		R&R-Invoice	Payroll Generated Invoice
72129	TOWER LOAN OF CANTON	PA71870945	06/15/2017	\$3.96		06/15/2017		R&R-Invoice	Payroll Generated Invoice
00445	J ALLEN SANDIFER AGENCY	PA71870123	06/15/2017	\$2.31		06/15/2017		R&R-Invoice	Payroll Generated Invoice
00445	J ALLEN SANDIFER AGENCY	PA71870127	06/15/2017	\$2.77		06/15/2017		R&R-Invoice	Payroll Generated Invoice
00445	J ALLEN SANDIFER AGENCY	PA71870129	06/15/2017	\$2.31		06/15/2017		R&R-Invoice	Payroll Generated Invoice
00478	UNITED WAY	PA71870163	06/15/2017	\$2.50		06/15/2017		R&R-Invoice	Payroll Generated Invoice
00478	UNITED WAY	PA71870164	06/15/2017	\$2.50		06/15/2017		R&R-Invoice	Payroll Generated Invoice
00529	POLICE HOSPITAL FUND	PA71840058	06/09/2017	\$2.31		06/09/2017		R&R-Invoice	Payroll Generated Invoice
00529	POLICE HOSPITAL FUND	PA71880057	06/16/2017	\$2.31		06/16/2017		R&R-Invoice	Payroll Generated Invoice
00765	AMERICAN HERITAGE LIFE INSURAN	PA71840080	06/09/2017	\$2.59		06/09/2017		R&R-Invoice	Payroll Generated Invoice
00765	AMERICAN HERITAGE LIFE INSURAN	PA71880078	06/16/2017	\$2.59		06/16/2017		R&R-Invoice	Payroll Generated Invoice
00445	J ALLEN SANDIFER AGENCY	PA71870126	06/15/2017	\$1.39		06/15/2017		R&R-Invoice	Payroll Generated Invoice
00478	UNITED WAY	PA71870165	06/15/2017	\$2.00		06/15/2017		R&R-Invoice	Payroll Generated Invoice
00478	UNITED WAY	PA71870167	06/15/2017	\$2.00		06/15/2017		R&R-Invoice	Payroll Generated Invoice

AP757

VENDOR PAYMENTS / FOR CLAIM DOCKET - 06/27/2017
 REPORT TITLE - AMOUNTS (DESCENDING) ALL TYPES
 Invoice Payments Under \$500

VEN#	VENDOR-NAME	INVOICE	INV-DATE	AMOUNT	AUTHORIZATION	DUE-DATE	REF-NUMBER	PAYMENT-TYPE	REMARKS
00523	AFLAC	PA71870280	06/15/2017	\$1.73		06/15/2017		R&R-Invoice	Payroll Generated Invoice
66394	COMPBENEFITS	PA71640119	06/09/2017	\$1.81		06/09/2017		R&R-Invoice	Payroll Generated Invoice
66394	COMPBENEFITS	PA71640125	06/09/2017	\$1.81		06/09/2017		R&R-Invoice	Payroll Generated Invoice
66394	COMPBENEFITS	PA71640126	06/09/2017	\$1.81		06/09/2017		R&R-Invoice	Payroll Generated Invoice
66394	COMPBENEFITS	PA71640127	06/09/2017	\$1.81		06/09/2017		R&R-Invoice	Payroll Generated Invoice
66394	COMPBENEFITS	PA71640128	06/09/2017	\$1.81		06/09/2017		R&R-Invoice	Payroll Generated Invoice
66394	COMPBENEFITS	PA71640129	06/09/2017	\$1.81		06/09/2017		R&R-Invoice	Payroll Generated Invoice
66394	COMPBENEFITS	PA71640130	06/09/2017	\$1.81		06/09/2017		R&R-Invoice	Payroll Generated Invoice
66394	COMPBENEFITS	PA71640133	06/09/2017	\$1.81		06/09/2017		R&R-Invoice	Payroll Generated Invoice
66394	COMPBENEFITS	PA71640135	06/09/2017	\$1.81		06/09/2017		R&R-Invoice	Payroll Generated Invoice
66394	COMPBENEFITS	PA71870859	06/15/2017	\$1.81		06/15/2017		R&R-Invoice	Payroll Generated Invoice
66394	COMPBENEFITS	PA71880117	06/16/2017	\$1.81		06/16/2017		R&R-Invoice	Payroll Generated Invoice
66394	COMPBENEFITS	PA71880123	06/16/2017	\$1.81		06/16/2017		R&R-Invoice	Payroll Generated Invoice
66394	COMPBENEFITS	PA71880124	06/16/2017	\$1.81		06/16/2017		R&R-Invoice	Payroll Generated Invoice
66394	COMPBENEFITS	PA71880125	06/16/2017	\$1.81		06/16/2017		R&R-Invoice	Payroll Generated Invoice
66394	COMPBENEFITS	PA71880126	06/16/2017	\$1.81		06/16/2017		R&R-Invoice	Payroll Generated Invoice
66394	COMPBENEFITS	PA71880127	06/16/2017	\$1.81		06/16/2017		R&R-Invoice	Payroll Generated Invoice
66394	COMPBENEFITS	PA71880128	06/16/2017	\$1.81		06/16/2017		R&R-Invoice	Payroll Generated Invoice
66394	COMPBENEFITS	PA71880131	06/16/2017	\$1.81		06/16/2017		R&R-Invoice	Payroll Generated Invoice
66394	COMPBENEFITS	PA71880133	06/16/2017	\$1.81		06/16/2017		R&R-Invoice	Payroll Generated Invoice
00651	SIMPSON LAW FIRM PA	PA71880060	06/16/2017	\$.63		06/16/2017		R&R-Invoice	Payroll Generated Invoice
71331	HEWITT LISA	PA41330006	01/29/2015	\$138.47-		01/29/2015		R&R-Invoice	Payroll Generated Invoice
00832	SHERETHA L MCGRUDER	PA41330004	01/29/2015	\$152.50-		01/29/2015		R&R-Invoice	Payroll Generated Invoice
63884	BENDER TERESA	PA41330005	01/29/2015	\$222.50-		01/29/2015		R&R-Invoice	Payroll Generated Invoice

*** Payments Under \$500 Total *** \$73,212.68

***** Grand-Total for Payroll Claims ***** \$150,060.81

OFFICE OF THE CITY ATTORNEY
 [Signature]

Office of the City Attorney
455 East Capitol Street

Post Office Box 2779
Jackson, Mississippi 39207-2779
Telephone: (601) 960-1799
Facsimile: (601) 960-1756

OFFICE OF THE CITY ATTORNEY

OFFICE OF THE CITY ATTORNEY
6/27/17

The PAYROLL DEDUCTION CLAIM for June 27, 2017
in the aggregate amount of \$150,060.81 has been reviewed by me,
based on information and belief, is legally sufficient for payment authorization and
placement in NOVUS Agenda.

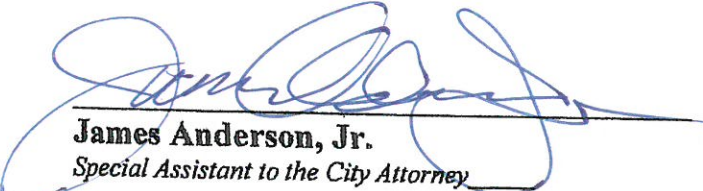
James Anderson, Jr.
Special Assistant to the City Attorney

6-27-17
DATE

OFFICE OF THE CITY ATTORNEY
6/12/17

ORDER AUTHORIZING THE SELL OF A 1992 E-ONE LADDER FIRE TRUCK TO THE HINDS COUNTY BOARD OF SUPERIORS FOR RAYMOND VOLUNTEER FIRE DEPARTMENT (ALL WARDS)

WHEREAS, the City of Jackson Fire Department is requesting authorization to sell Truck 341 to the Raymond Volunteer Fire Department.

WHEREAS, the 1992 E-One Ladder Fire Truck would be sold for \$15,000.

IT IS, HEREBY, ORDERED that the Fire Department be to allowed to sell TK341 to Hinds County Board of Supervisors for Raymond Volunteer Fire Department.

IT IS, FURTHER, ORDERED that the Mayor is authorized to execute all necessary agreements, title, and other documents to faciliate the sael of the referenced fire truck.

Item No. 8

Agenda Date: _____

By: Yarber, Simpson

CITY COUNCIL AGENDA ITEM 10 POINT DATA SHEET

June 9, 2017

DATE

POINTS		COMMENTS			
1.	Brief Description/Purpose	ORDER AUTHORIZING THE SELL OF A 1992 E-ONE LADDER FIRE TRUCK TO THE HINDS COUNTY BOARD OF SUPERIORS FOR RAYMOND VOLUNTEER FIRE DEPARTMENT (ALL WARDS)			
2.	Public Policy Initiative 1. Youth & Education 2. Crime Prevention 3. Changes in City Government 4. Neighborhood Enhancement 5. Economic Development 6. Infrastructure and Transportation 7. Quality of Life	Quality of Life			
3.	Who will be affected	City of Jackson			
4.	Benefits	To provide safety to the citizens of Jackson			
5.	Schedule (beginning date)	As soon as possible			
6.	Location: ■ WARD ■ CITYWIDE (yes or no) (area) ■ Project limits if applicable	ALL WARDS CITY WIDE			
7.	Action implemented by: ■ City Department <input type="checkbox"/> ■ Consultant <input type="checkbox"/>	Jackson Fire Department			
8.	COST	NA			
9.	Source of Funding ■ General Fund <input type="checkbox"/> ■ Grant <input type="checkbox"/> ■ Bond <input type="checkbox"/> ■ Other <input type="checkbox"/>				
10.	EBO participation	ABE _____% AABE _____% WBE _____% HBE _____% NABE _____%	WAIVER yes ___ no ___ WAIVER yes ___ no ___ WAIVER yes ___ no ___ WAIVER yes ___ no ___ WAIVER yes ___ no ___	N/A ___ N/A ___ N/A ___ N/A ___ N/A ___	

Jackson Fire Department



555 South West Street
Post Office Box 17
Jackson, Mississippi 39205-0017

MEMORANDUM

To: Tony T. Yarber, Mayor City of Jackson

From: R.D. Simpson, Chief of Fire Department *RD Simpson*

Subject: Sell of a 1992 E-One Ladder Truck

Date: June 9, 2017

The Jackson Fire Department is requesting permission to sell a 1992 E- One Ladder Truck, Truck 341, to Hinds County Board of Supervisors for Raymond Volunteer Fire Department for \$15,000.

We respectfully request your signature approving the document contained herein. Should you have any questions or concerns, please do not hesitate to contact me.

Office of the City Attorney

455 East Capitol Street
Post Office Box 2779
Jackson, Mississippi 39207-2779
Telephone: (601) 960-1799
Facsimile: (601) 960-1756

OFFICE OF THE CITY ATTORNEY

This ORDER AUTHORIZING THE SELL OF A 1992 E-ONE LADDER FIRE TRUCK TO THE HINDS COUNTY BOARD OF SUPERIORS FOR RAYMOND VOLUNTEER FIRE DEPARTMENT (ALL WARDS) is legally sufficient for placement in NOVUS Agenda.

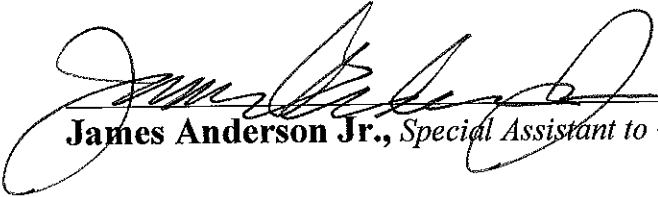
James Anderson Jr., *Special Assistant to City Attorney*

6-12-17
DATE

CERTIFICATE OF TITLE

STATE OF MISSISSIPPI

VEHICLE IDENTIFICATION NUMBER: 4ENBAA80N1000422
MAKE: EMER
YEAR: 92
MODEL: HUR
BODY: HR
TITLE NUMBER: 6125622-01
TITLE DATE: 12/09/92
DATE OF FIRST SALE FOR USE NEW ONLY: 11/05/92
NO. CYL: 06
NEW/USED: X
TYPE OF VEHICLE: AMBUL
PASS. OR GVW: 000
ORIGINAL

OWNER:
JACKSON CITY OF
BX 17 SOUTH WEST ST
JACKSON MS 39205

ODOMETER - TENTHS NOT INCLUDED
001205
ACTUAL MILEAGE

1ST LIENHOLDER (OR OWNER IF NO LIEN)
JACKSON CITY OF
BX 17 SOUTH WEST ST
JACKSON MS 39205

DATE
MO. | DAY | YR.

2ND LIENHOLDER

DATE
MO. | DAY | YR.

LIEN SATISFACTION —
THE UNDERSIGNED HOLDER OF ABOVE DESCRIBED LIEN(S) ON THE MOTOR VEHICLE DESCRIBED HEREON HEREBY ACKNOWLEDGES SATISFACTION THEREOF.

1ST LIEN _____ (LIENHOLDER) BY _____ (SIGNATURE AND TITLE)

THIS _____ DAY OF _____, 19____

2ND LIEN _____ (LIENHOLDER) BY _____ (SIGNATURE AND TITLE)

THIS _____ DAY OF _____, 19____



IN WITNESS WHEREOF I HAVE HEREUNTO SET MY HAND THIS
09 DAY OF DECEMBER 1992

92339138007

00107
STATE TAX COMMISSION

The Mississippi State Tax Commission hereby certifies that on application duly made, the person named herein is registered by this office as the lawful owner of the vehicle described subject to the liens or security interests herein set forth and such liens or security interests as may subsequently be filed with the State Tax Commission. This certificate of title is issued pursuant to the Mississippi Motor Vehicle Title Law Section 63-2-11, Mississippi Code of 1972, and subject to the provisions thereof.

CONTROL NUMBER
6358968

[Signature]
STATE TAX COMMISSION

VOID IF ALTERED

PURCHASED THRU

GEN FUND - 001

ACC # 44120

OFFICE OF THE CITY ATTORNEY
6/29/17

ORDER AUTHORIZING THE MAYOR'S SUBMISSION AND ACCEPTANCE OF THE 2017 FUNDING OPPORTUNITY ANNOUNCEMENT AND STAKEHOLDER INPUT GRANT

WHEREAS, the City of Jackson has been granted the opportunity to apply for the 2017 Mississippi Office of Homeland Security Funding Opportunity Announcement and Stakeholder Input Grant, and

WHEREAS, the City of Jackson will receive allocation from the Mississippi Office of Homeland Security, and

WHEREAS, funds through this grant will be used to purchase a command center trailer for the Jackson Police Department Bomb Squad; and

WHEREAS, the 2017 Funding Opportunity Announcement and Stakeholder Input Grant requires no matching funds.

IT IS HEREBY ORDERED that the Mayor or his designee is authorized to submit an application for the 2017 Funding Opportunity Announcement and Stakeholder Input Grant.

IT IS FURTHERED ORDERED that the Mayor or his designee be authorized to execute any and all necessary documents for the acceptance and administration of said grant if it is awarded.

APPROVED FOR AGENDA:

Agenda date #9
Agenda item#
By: VANCE, YARBER.

Jackson Police Department



327 East Pascagoula Street
Post Office Box 17
Jackson, Mississippi 39205-0017

MEMORANDUM

To: Tony T. Yarber, Mayor

From: Lee Vance, Chief of Police *L.V.*

Subject: **Funding Opportunity Announcement – Command Trailer**

Date: June 20, 2017

The Jackson Police Department has been granted the opportunity to apply for the Funding Opportunity Announcement and Stakeholder Input Grant Program. This award will be used to purchase a Command Trailer for the Bomb Squad which will equip them for safer and more efficient operations. There is no match requirement to participate in this program.

We respectfully request your signature approving the document contained herein. Should you have any questions or concerns, please do not hesitate to contact me.

CITY COUNCIL AGENDA ITEM 10 POINT DATA SHEET

June 20, 2017
DATE

P O I N T S		C O M M E N T S					
1.	Brief Description/Purpose	Order authorizing the Mayor's submission and acceptance of the 2017 Funding Opportunity Announcement and Stakeholder Input Grant Program administrated by Mississippi Office of Homeland Security.					
2.	Public Policy Initiative 1. Youth & Education 2. Crime Prevention 3. Changes in City Government 4. Neighborhood Enhancement 5. Economic Development 6. Infrastructure and Transportation 7. Quality of Life	Crime Prevention					
3.	Who will be affected	City of Jackson					
4.	Benefits	To provide the Jackson Police Department Bomb Squad with protective equipment necessary for safe and efficient operations.					
5.	Schedule (beginning date)	As per grant guidelines					
6.	Location: ▪ WARD ▪ CITYWIDE (yes or no) (area) ▪ ▪ Project limits if applicable	ALL WARDS CITY WIDE					
7.	Action implemented by: ▪ City Department <input type="checkbox"/> ▪ Consultant <input type="checkbox"/>	Jackson Police Department					
8.	COST	None					
9.	Source of Funding ▪ General Fund <input type="checkbox"/> ▪ Grant <input type="checkbox"/> ▪ Bond <input type="checkbox"/> ▪ Other <input type="checkbox"/>	Mississippi's State Homeland Security Grant					
10.	EBO participation	ABE	_____ %	WAIVER	yes ___	no ___	N/A ___
		AABE	_____ %	WAIVER	yes ___	no ___	N/A ___
		WBE	_____ %	WAIVER	yes ___	no ___	N/A ___
		HBE	_____ %	WAIVER	yes ___	no ___	N/A ___
		NABE	_____ %	WAIVER	yes ___	no ___	N/A ___

Office of the City Attorney

455 East Capitol Street
Post Office Box 2779
Jackson, Mississippi 39207-2779
Telephone: (601) 960-1799
Facsimile: (601) 960-1756



OFFICE OF THE CITY ATTORNEY

This **ORDER AUTHORIZING THE MAYOR'S SUBMISSION AND ACCEPTANCE OF THE 2017 FUNDING OPPORTUNITY ANNOUNCEMENT AND STAKEHOLDER INPUT GRANT** is legally sufficient for placement in NOVUS Agenda.

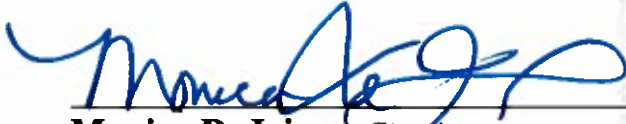

Monica D. Joiner, *City Attorney*

Gregory Burnett, *Deputy City Attorney* GB

6/20/17
DATE

2017 NIMS COMPLIANCE FORM

**To: The Mississippi Office of Homeland Security
1230 Raymond Rd.
Jackson, MS 39204**

Attn: Office of Grants

Homeland Security Directive 5 mandates governments shall implement a consistent system for working together during incidents or events. The National Incident Management System (NIMS) has been designed to provide effective incident and event management. NIMSCAST has been designed for recording said NIMS compliance. Mississippi under Executive Order #932 established NIMS as the standard for incident management within the state. Department of Homeland Security/Federal Emergency Management Agency guidance provides that accepting grant funding is conditional on compliance with NIMS. This jurisdiction attests that we continue to strive toward NIMS compliance as provided under federal and state NIMS guidance. This jurisdiction also attests that compliance shall be correctly recorded within the NIMSCAST tool. This jurisdiction understands receiving and/or using Homeland Security grant funds remains conditional upon successful participation in respect to NIMS compliance and reporting. Non-compliance of NIMS can result in Homeland Security dollars being withheld from or drawn back from our jurisdiction because of ineffective NIMS support and participation.

This understood and attested to:

Signed: _____

Printed name: _____

Jurisdiction represented: _____

Dated: _____

Witness sign: _____

Printed name: _____

ORDER AUTHORIZING THE MAYOR TO ENTER INTO A TWELVE MONTH AGREEMENT WITH SCHINDLER ELEVATOR CORPORATION FOR ELEVATOR MAINTENANCE TO BE USED BY JATLAN AT THE JATLAN ADMINISTRATIVE/MAINTENANCE FACILITY COMMENCING MAY 1, 2017

OFFICE OF THE CITY ATTORNEY
6/13/17

WHEREAS, the City of Jackson, Mississippi, desires to enter into a 12-month maintenance agreement for the elevator located at JAMF, 1785 Highway 80 W; and

WHEREAS, the City of Jackson Department of Planning and Development, Office of Transportation has determined that it may enter into an agreement with Schindler Elevator Corporation pursuant to Miss Code Ann §31-7-13 (a), as it is the best method of procurement to maintain the elevator certification and maintenance; and

WHEREAS, Schindler Elevator Corporation has been determined to be the most responsive and responsible to provide elevator maintenance services for a twelve month commencing on May 1, 2017 through April 30, 2018 based on Schindler Elevator Corporation's response and experience in elevator maintenance and having prior knowledge of the current equipment; and

WHEREAS, the cost shall not exceed the sum of \$2,152.56, which is covered by FTA funds and the City's local match in FY17 and;

IT IS THEREFORE, ORDERED that the Mayor is authorized to enter into a twelve month agreement with Schindler Elevator Corporation for the provision of elevator maintenance at the JATLAN Administrative and Maintenance Facility for an amount not to exceed \$2,152.56 through April 30, 2018.

IT IS FURTHER ORDERED that the services shall be paid for using Federal Transit Administration (FTA) grant funds at 80% (1,722.05) and local match from General Fund at 20% (\$430.51) to the Office of Transportation

Item# 10
Agenda Date: June 13, 2017
By: (Welch, Jefferson, Yarber)

MEMORANDUM

TO: Tony T. Yarber, Mayor

THRU: Eric Jefferson, Director
Department of Planning & Development

FROM: Christine Welch, Deputy Director *CW*
Office of Transportation

DATE: June 6, 2017

RE: Agenda Item for June 13, 2017 City Council Meeting

The attached agenda item authorizes the Mayor to enter into an Agreement with Schindler Elevator Corporation to maintain the elevator at the JATRAN Administration and Maintenance Facility for a twelve month period from May 1, 2017 to April 30, 2018 for an amount not to exceed \$2,152.56.

On April 5, 2017, the Office of Transportation issued a request for quotes to contractors to provide elevator maintenance contracts for the elevator located at JAMF, 1785 Highway 80W. There was only one company that submitted a quote: Schindler Elevator Corporation.

The Office of Transportation was previously advised by the Department of Public Works that JATRAN Administration and Maintenance Facility's elevator could not be added to the City's master agreement.

It is the recommendation of this department that this application submittal be approved. If you have any questions, please call Christine Welch, Deputy Director, Department of Planning and Development/Office of Transportation at (601) 960-1909 or e-mail cwelch@city.jackson.ms.us.

Office of the City Attorney

455 East Capitol Street
Post Office Box 2779
Jackson, Mississippi 39207-2779
Telephone: (601) 960-1799
Facsimile: (601) 960-1756

OFFICE OF THE CITY ATTORNEY

This ORDER AUTHORIZING THE MAYOR TO ENTER INTO A TWELVE MONTH AGREEMENT WITH SCHINDLER ELEVATOR CORPORATION FOR ELEVATOR MAINTENANCE TO BE USED BY JATLAN AT THE JATLAN ADMINISTRATIVE/MAINTENANCE FACILITY COMMENCING MAY 1, 2017 is legally sufficient for placement in NOVUS Agenda.



Monica D. Joiner, City Attorney

Dana Sims, Deputy City Attorney

PPS

6/7/17

DATE

OFFICE OF THE CITY ATTORNEY
PPS
6/7/17



OFFICE OF THE CITY ATTORNEY
3/29/17

ORDER AUTHORIZING THE MAYOR TO EXECUTE A MEMORANDUM OF UNDERSTANDING BETWEEN THE CITY OF JACKSON, MISSISSIPPI, AND MISSISSIPPI ROADMAP TO HEALTH EQUITY AND URBAN LEAGUE, INCORPORATED, FOR THE LEASE AND MANAGEMENT OF THE CITY'S GROVE PARK MUNICIPAL GOLF COURSE.

WHEREAS, the City of Jackson, Mississippi ("City"), owns certain real property upon which Grove Park Municipal Golf Course is operated; and

WHEREAS, the governing authorities of the City believe that the best interest of the City, as well as its citizens, would be best served by a community collaboration with a non-profit organization willing to invest in the Grove Park Municipal Golf Course to ensure it remains open to the public, and will oversee the management and operations of said golf course; and

WHEREAS, Mississippi Roadmap to Health Equity and Urban League, Incorporated supports the City's objectives and desire to keep Grove Park Municipal Golf Course open to the public and viable amidst stringent budgetary times.

IT IS HEREBY ORDERED that the Mayor be authorized to execute a Memorandum of Understanding between the City of Jackson, Mississippi, and Mississippi Roadmap to Health Equity and Urban League, Incorporated, for the lease and management of Grove Park Municipal Golf Course for a period of ten (10) years commencing April 15, 2017 and ending April 14, 2027, with an option to extend for two (2) renewal terms of four (4) years each.

Office of the City Attorney

455 East Capitol Street
Post Office Box 2779
Jackson, Mississippi 39207-2779
Telephone: (601) 960-1799
Facsimile: (601) 960-1756

OFFICE OF THE CITY ATTORNEY

This ORDER AUTHORIZING THE MAYOR TO EXECUTE A MEMORANDUM OF UNDERSTANDING BETWEEN THE CITY OF JACKSON, MISSISSIPPI, AND MISSISSIPPI ROADMAP TO HEALTH EQUITY AND URBAN LEAGUE, INCORPORATED, FOR THE LEASE AND MANAGEMENT OF THE CITY'S GROVE PARK MUNICIPAL GOLF COURSE is legally sufficient for placement in NOVUS Agenda.

OFFICE OF THE CITY ATTORNEY
3/29/17
Monica D. Joiner



Monica D. Joiner, City Attorney

3/29/17

DATE

**ORDER RATIFYING A CONTRACT WITH HEMPHILL
CONSTRUCTION COMPANY FOR THE LONGWOOD DRIVE
EMERGENCY WATER & SEWER REPAIR , CITY PROJECT NO.
17B0501.601 (WARD 6)**

WHEREAS, the Department of Public Works discovered both the water and sewer line pipes on Longwood Driver were damaged by the April 2, 2017 rainfall storm event causing raw sewer to discharge into Cany Creek, and loss of water pressure due to a break in the waterline; and

WHEREAS, the Mayor declared an emergency, under Section 31-7-13(k) of the Mississippi Code of 1972, as amended, because the failure of the waterline has caused disruption of water supply to citizens in Ward 6, and leakage from the collapsed sewer line discharging raw sewerage into Cany Creek is a violation of the Clean Water Act; and

WHEREAS, the City of Jackson solicited quotes from two contractors: Hemphill Construction Company, Inc., and Delta Constructors, Inc., to repair the water and sewer lines; and

WHEREAS, the City of Jackson accepted lowest and best quote from Hemphill Construction Company, Inc., in amount of \$336,850.00; and

WHEREAS, a final field inspection was held by the Department of Public Works and recommends acceptance of the project; and

WHEREAS, the original quote amount was for \$336,850.00, and the decreased amount is \$297,295.00; and

WHEREAS, the Department of Public Works recommends final payment in the amount of \$297,295.00 to Hemphill Construction Company, Inc.; and

WHEREAS, the bonding company Federal Insurance Company, Attorney-in-fact, surety on performance of the said contract, has authorized release and payment of all money due under said contract; and

IT IS, THEREFORE, ORDERED that the contract with Hemphill Construction Company, Inc., for emergency repair work in the amount of \$297,295.00 is ratified.

IT IS FURTHER ORDERED that the City make final payments in the amount of \$297,295.00 to Hemphill Construction Company, Inc., and release all securities held to Hemphill Construction, Inc., for all the work completed and materials furnished under this contract and that the City Clerk publish the Notice of Completion of the Longwood Drive Emergency Water & Sewer Repair, City Project No. 17B0501.601.

ITEM # _____

DATE: _____

BY: SMASH, WILLIAMS, YARBER

CITY COUNCIL AGENDA ITEM 10 POINT DATA SHEET
June 2, 2017

OFFICE OF THE CITY ATTORNEY
 JUNE 16, 2017

P O I N T S		C O M M E N T S																																													
1.	Brief Description/Purpose	ORDER RATIFYING A CONTRACT WITH HEMPHILL CONSTRUCTION COMPANY FOR THE LONGWOOD DRIVE EMERGENCY WATER & SEWER REPAIR , CITY PROJECT NO. 17B0501.601 (WARD 6)																																													
2.	Public Policy Initiative 1. Youth & Education 2. Crime Prevention 3. Changes in City Government 4. Neighborhood Enhancement 5. Economic Development 6. Infrastructure and Transportation 7. Quality of Life	This item addresses Items 5, 6, and 7																																													
3.	Who will be affected	All residents of the City of Jackson																																													
4.	Benefits	Water & Sewer Infrastructure																																													
5.	Schedule (beginning date)	This project is complete																																													
6.	Location: ▪ WARD ▪ CITYWIDE (yes or no) (area) ▪ Project limits if applicable	This project is located in Ward 6																																													
7.	Action implemented by: ▪ City Department <input checked="" type="checkbox"/> ▪ Consultant <input type="checkbox"/>	This project was implemented by the Engineering Division.																																													
8.	COST	Final Cost: \$297,295.00																																													
9.	Source of Funding ▪ General Fund <input type="checkbox"/> ▪ Grant <input type="checkbox"/> ▪ Bond <input type="checkbox"/> ▪ Other <input checked="" type="checkbox"/>	032-52290-7B0501-601-6485																																													
10.	EBO participation	<table border="0"> <tr> <td>ABE</td> <td>_____ %</td> <td>WAIVER</td> <td>yes</td> <td>___</td> <td>no</td> <td>___</td> <td>N/A</td> <td>___</td> </tr> <tr> <td>AABE</td> <td>_____ %</td> <td>WAIVER</td> <td>yes</td> <td>___</td> <td>no</td> <td>___</td> <td>N/A</td> <td>___</td> </tr> <tr> <td>WBE</td> <td>_____ %</td> <td>WAIVER</td> <td>yes</td> <td>___</td> <td>no</td> <td>___</td> <td>N/A</td> <td>___</td> </tr> <tr> <td>HBE</td> <td>_____ %</td> <td>WAIVER</td> <td>yes</td> <td>___</td> <td>no</td> <td>___</td> <td>N/A</td> <td>___</td> </tr> <tr> <td>NABE</td> <td>_____ %</td> <td>WAIVER</td> <td>yes</td> <td>___</td> <td>no</td> <td>___</td> <td>N/A</td> <td>___</td> </tr> </table>	ABE	_____ %	WAIVER	yes	___	no	___	N/A	___	AABE	_____ %	WAIVER	yes	___	no	___	N/A	___	WBE	_____ %	WAIVER	yes	___	no	___	N/A	___	HBE	_____ %	WAIVER	yes	___	no	___	N/A	___	NABE	_____ %	WAIVER	yes	___	no	___	N/A	___
ABE	_____ %	WAIVER	yes	___	no	___	N/A	___																																							
AABE	_____ %	WAIVER	yes	___	no	___	N/A	___																																							
WBE	_____ %	WAIVER	yes	___	no	___	N/A	___																																							
HBE	_____ %	WAIVER	yes	___	no	___	N/A	___																																							
NABE	_____ %	WAIVER	yes	___	no	___	N/A	___																																							



**City of Jackson
Department of Public Works**

Talking Points:

Longwood Drive Emergency Water & Sewer Repair

- The City of Jackson maintenance crews discovered a break on the water and sewer line resulting from the April 2, 2017 rainfall storm event.
- The Mayor declared an emergency to authorize the repair of the waterline to minimize the impact of water loss to the City of Jackson residents living in South Jackson. The
- The emergency also allowed for the repair of the sanitary sewer line that was damaged from the rainfall storm event violating the Clean Water Act.
- Hemphill Construction Company provided the Public Works Department with lowest and best quote.
- The work has been completed, and inspected by the Public Works Department.
- The Public Works Department recommends final payment to Hemphill Construction Company, Inc.



City of Jackson
Department of Public Works

Council Agenda Item Memorandum

To: Tony T. Yarber
From: Jerriot Smash, Interim Director 
Date: June 2, 2017

Agenda Item: Longwood Drive Emergency Water & Sewer Repair
Item #:
Council Meeting: Regular Council Meeting, June 13, 2017
Consultant/Contractor: N/A
EBO Compliance Details:

Purpose: Water & Sewer Infrastructure Repair
Cost: Final Cost: \$297,295.00
Project/Contract Type: Water & Sewer Repair
Funding Source: Fund 32 Water/Sewer Revenue Bond
Schedule/Time: Completed
DPW Manager: Charles Williams Jr., PE, PhD/William "Bill" Miley

Background:

Attached, you will find an item for the City Council Agenda requesting to ratify a contract with Hemphill Construction Company Inc., for the Longwood Drive Emergency Water & Sewer Repair.

The emergency was required due to the water and sewer lines located on Longwood Drive were damaged from the April 2, 2017 rainfall storm event. The damage to the waterline caused a significant water outage to the South Jackson area. In addition the damage to the sewerline caused raw sewer to discharge into Cany Creek violating the Clean Water Act. The Mayor declared an emergency based on the storm event to allow solicitation of quotes from contractors to repair both critical both lines. The work was done in accordance with the specifications, and the Public Works recommends approval of final payment to Hemphill Construction Company. If you have any questions, or require additional information, please do not hesitate to contact this office at (601) 960-2091.

Office of the City Attorney

455 East Capitol Street
Post Office Box 2779
Jackson, Mississippi 39207-2779
Telephone: (601) 960-1799
Facsimile: (601) 960-1756

OFFICE OF THE CITY ATTORNEY

This **ORDER RATIFYING A CONTRACT WITH HEMPHILL CONSTRUCTION COMPANY FOR THE LONGWOOD DRIVE EMERGENCY WATER & SEWER REPAIR, CITY PROJECT NO. 17B0501.601 (WARD6)** is legally sufficient for placement in NOVUS Agenda.

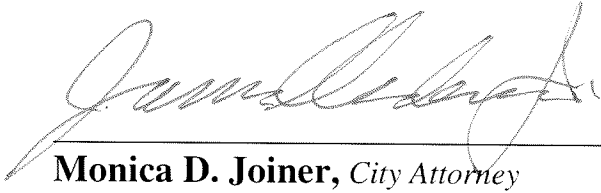

Monica D. Joiner, *City Attorney*
Nakesha Watkins, *Legal Counsel* NW

6-16-17

DATE

OFFICE OF THE CITY ATTORNEY
JUNE 16 2017
N.W.

ORDER AUTHORIZING THE MAYOR TO EXECUTE A PRELIMINARY ENGINEERING SERVICES CONTRACT WITH WAGGONER ENGINEERING, INC., FOR THE STATE STREET RESURFACING PROJECT (FORTIFICATION STREET TO WOODROW WILSON AVENUE), FEDERAL AID PROJECT NO. STP-6928-00(013) LPA/107548, CITY PROJECT NO. 17B4001 (WARD 7)

CITY ATTORNEY
11/19/2017
RWW

WHEREAS, the City of Jackson made application for and received \$3,888,750.00 in FAST Act federal transportation funds through the Jackson MPO for the pavement rehabilitation and resurfacing of State Street from Fortification Street to Woodrow Wilson Avenue with a required minimum 25% match; and

WHEREAS, the City of Jackson selected Waggoner Engineering, Inc., to perform necessary preliminary engineering services for the project; and

WHEREAS, Waggoner has provided a cost estimate of \$283,517.07 to provide preliminary engineering services for the project.

IT IS THEREFORE ORDERED that the Mayor is authorized to execute a preliminary engineering services contract with Waggoner Engineering, Inc., for the State Street Resurfacing Project, Federal Aid Project No. STP-6928-00(013) LPA/107548, City Project No. 17B4001, for an amount not to exceed \$283,517.07.

Item#: 13 _____

Agenda: _____

By: Smash, Williams, R. Lee, Yarber

CITY COUNCIL AGENDA ITEM 10 POINT DATA SHEET

June 16, 2017

DATE

OFFICE OF THE CITY ATTORNEY
CITY OF WASHINGTON
JUN 16 2017

POINTS		COMMENTS
1.	Brief Description	Order authorizing the Mayor to execute a preliminary engineering services contract with Waggoner for the State Street Resurfacing Project
2.	Public Policy Initiative 1. Youth & Education 2. Crime Prevention 3. Changes in City Government 4. Neighborhood Enhancement 5. Economic Development 6. Infrastructure and Transportation 7. Quality of Life	4, 6, 7
3.	Who will be affected	Residents, businesses, and motorists along State Street
4.	Benefits	Provide engineering services for a federal aid resurfacing project
5.	Schedule (beginning date)	After City Council approval.
6.	Location: ▪ WARD ▪ CITYWIDE (yes or no) (area) ▪ Project limits if applicable	State Street from Fortification Street to Woodrow Wilson Avenue (Ward 7)
7.	Action implemented by: ▪ City Department <input checked="" type="checkbox"/> ▪ Consultant <input type="checkbox"/>	Public Works Department, Engineering Division
8.	COST	\$283,517.07
9.	Source of Funding ▪ General Fund <input type="checkbox"/> ▪ Grant <input type="checkbox"/> ▪ Bond <input type="checkbox"/> ▪ Other <input checked="" type="checkbox"/>	Municipal Sales Tax Acct # 173 45135 7B4001701 6413
10.	EBO participation	ABE _____ % WAIVER yes ___ no ___ N/A _____ AABE _____ % WAIVER yes ___ no ___ N/A _____ WBE _____ % WAIVER yes ___ no ___ N/A _____ HBE _____ % WAIVER yes ___ no ___ N/A _____ NABE _____ % WAIVER yes ___ no ___ N/A _____

Department of Public Works



200 South President Street
Post Office Box 17
Jackson, Mississippi 39205-0017

Tony Yarber
Mayor of the City of Jackson

MEMORANDUM

To: Mayor Tony Yarber

From: Jerriot Smash 
Interim Director

Date: June 16, 2017

Subject: Agenda Item for City Council Meeting

Attached you will find an item for the agenda authorizing the Mayor to execute a preliminary engineering services contract with Waggoner Engineering, Inc., for the State Street Resurfacing Project from Fortification Street to Woodrow Wilson Avenue.

The City of Jackson has \$1,415,681.00 in regional surface transportation project construction funds from FAST Act for the pavement rehabilitation and resurfacing of State Street from Fortification Street to Woodrow Wilson Avenue. The City selected Waggoner Engineering for the necessary preliminary engineering work. The amount of the preliminary engineering services contract will not exceed \$283,517.07.

If you have any questions or comments, please do not hesitate to call me at (601) 960-2091.

Office of the City Attorney

455 East Capitol Street
Post Office Box 2779
Jackson, Mississippi 39207-2779
Telephone: (601) 960-1799
Facsimile: (601) 960-1756

OFFICE OF THE CITY ATTORNEY

This ORDER AUTHORIZING THE MAYOR TO EXECUTE A PRELIMINARY ENGINEERING SERVICES CONTRACT WITH MICHAEL BAKER INTERNATIONAL, FOR THE WOODROW WILSON AVENUE RESURFACING FROM MILL STREET TO I-55, FEDERAL AID PROJECT NO. STP-7281-00(004) LPA/107549-701000, CITY PROJECT NO. 17B4003.701 (WARDS 7) is legally sufficient for placement in NOVUS Agenda.



Monica D. Joiner, *City Attorney*

Nakesha Watkins, *Legal Counsel* 

DATE

ORDER AUTHORIZING ACCEPTANCE AND DONATION OF PERMANENT EASEMENTS BETWEEN THE CITY OF JACKSON AND THE STATE OF MISSISSIPPI FOR THE LEFLEUR EAST TRAIL

OFFICE OF THE CITY ATTORNEY
JUN 19 2017

WHEREAS, the State of Mississippi owns a certain parcel of real estate and improvements situated in Jackson, Mississippi, generally located south of Eastover Drive, east of Interstate 55 and west of Ridgewood Road; and

WHEREAS, the State of Mississippi desires to construct a shared-used trail next to Eastover Drive with the trail cross onto Eastover Drive right-of-way at certain locations; and the City of Jackson desires to a grant a permanent easement to the State of Mississippi to permit the construction and maintenance of the LeFleur East trail

WHEREAS, the City of Jackson desires to have the LeFleur East trail serve as a sidewalk and shared-use trail next to Eastover Drive in the same manner as if it were built wholly on public right-of-way, and the State of Mississippi desires to grant a permanent easement to the City of Jackson to permit the use of the LeFleur East trail on state land in the same manner as City right-of-way.

IT IS THEREFORE, ORDERED that City of Jackson hereby grants, conveys, and donates to the State of Mississippi, for the benefit of the property and lawful users thereof, an easement over and across the public right-of-way of Eastover Drive for the construction and maintenance of the LeFleur East trail.

IT IS FURTHER, ORDERED that City of Jackson hereby accepts from the State of Mississippi, for the benefit of the public, an easement over and across land owned by State of Mississippi for the public right-of-way use of the LeFleur East Trail.

Item#: 14 _____

Agenda: _____

By: Smash, Williams, R. Lee, Yarber

CITY COUNCIL AGENDA ITEM 10 POINT DATA SHEET

June 16, 2017

DATE

OFFICE OF THE CITY CLERK
June 19 2017
CITY CLERK

POINTS		COMMENTS
1.	Brief Description	Order authorizing permanent easement between the City of Jackson and the State of Mississippi for the LeFleur East Trail
2.	Public Policy Initiative 1. Youth & Education 2. Crime Prevention 3. Changes in City Government 4. Neighborhood Enhancement 5. Economic Development 6. Infrastructure and Transportation 7. Quality of Life	4, 6, 7
3.	Who will be affected	Pedestrians and cyclists along Eastover Drive
4.	Benefits	Grants an easement for construction and maintenance for the parts of LeFleur East Trail that will be built on City right-of-way and accepts easement for public use of the trail on state land.
5.	Schedule (beginning date)	After City Council approval.
6.	Location: ▪ WARD ▪ CITYWIDE (yes or no) (area) ▪ Project limits if applicable	Eastover Dr from the District at Eastover to Ridgewood Rd (Ward 7)
7.	Action implemented by: ▪ City Department <input checked="" type="checkbox"/> ▪ Consultant <input type="checkbox"/>	Public Works Department, Engineering Division
8.	COST	No cost to the City. The trail will be constructed by DFA with State funds.
9.	Source of Funding ▪ General Fund <input type="checkbox"/> ▪ Grant <input type="checkbox"/> ▪ Bond <input type="checkbox"/> ▪ Other <input checked="" type="checkbox"/>	N/A
10.	EBO participation	ABE _____ % WAIVER yes ___ no ___ N/A _____ AABE _____ % WAIVER yes ___ no ___ N/A _____ WBE _____ % WAIVER yes ___ no ___ N/A _____ HBE _____ % WAIVER yes ___ no ___ N/A _____ NABE _____ % WAIVER yes ___ no ___ N/A _____

Department of Public Works



200 South President Street
Post Office Box 17
Jackson, Mississippi 39205-0017

Tony Yarber
Mayor of the City of Jackson

MEMORANDUM

To: Mayor Tony Yarber

From: Jerriot Smash 
Interim Director

Date: June 16, 2017

Subject: Agenda Item for City Council Meeting

Attached you will find an item for the agenda authorizing the Mayor to accept and donate permanent easements between the City and the State of Mississippi for the LeFleur East shared use trail.

The Legislature allocated funds to the Department of Finance and Administration for construction of a shared use trail along the south side of Eastover Drive next to State-owned facilities including the Education and Research Complex, the Department of Wildlife Fisheries and Parks, the Mississippi School for the Blind, and Mississippi School for the Deaf. Most of the trail will be on state land, but each end of the trail will connect to pedestrian facilities on City right-of-way, and portions near the IHL entrance and the MSD/MSB entrance must transition onto City right-of-way to bypass large obstructions. The trail will serve as a de-facto public sidewalk along Eastover Dr. This order authorizes donation of a permanent easement to the State of Mississippi and acceptance of a permanent easement from the State for the trail.

If you have any questions or comments, please do not hesitate to call me at (601) 960-2091.

Office of the City Attorney

455 East Capitol Street
Post Office Box 2779
Jackson, Mississippi 39207-2779
Telephone: (601) 960-1799
Facsimile: (601) 960-1756

OFFICE OF THE CITY ATTORNEY

This **ORDER AUTHORIZING ACCEPTANCE AND DONATION OF PERMANENT EASEMENT BETWEEN THE CITY OF JACKSON AND THE STATE OF MISSISSIPPI FOR THE LEFLEUR EAST TRAIL** is legally sufficient for placement in NOVUS Agenda.



Monica D. Joiner, *City Attorney*

Nakesha Watkins, *Legal Counsel*

6/19/17

DATE

OFFICE OF THE CITY ATTORNEY
June 15, 2017

ORDER AUTHORIZING THE MAYOR TO EXECUTE SUPPLEMENTAL AGREEMENT #1 TO THE CONTRACT OF HEMPHILL CONSTRUCTION COMPANY, INC. FOR THE TRAFFIC CALMING PROJECT, FEDERAL AID PROJECT NUMBER TCSP-0250-00(046)/103924, CITY PROJECT NUMBER 31500 (ALL WARDS)

*THE CITY ATTORNEY
JRE 12 2011
RW*

WHEREAS, the City of Jackson executed a contract with Hemphill Construction Company, Inc. for the City of Jackson Traffic Calming Project; and

WHEREAS, during construction, the City and the contractor determined that additional construction signage was needed at each under-construction speed bump to provide extra warning for motorist; and

WHEREAS, the contractor determined that it needed 20 large Dip signs at a cost of \$29.06 per square foot for a total cost of \$9,299.20, and Mississippi Department of Transportation has reviewed the proposal and found the pay item cost acceptable and allowable under the 100% federal funds.

IT IS, THEREFORE, ORDERED that the Mayor is authorized to execute Supplemental Agreement #1 to the contract of Hemphill Construction Company, Inc. for the Traffic Calming Project, Federal Aid Project Number TCSP-0250-00(046)/103924, City Project Number 31500, increasing the amount of the contract by \$9,299.20 with the new contract amount being \$350,888.40.

ITEM 15

AGENDA _____

BY: SMASH, WILLIAMS, R. LEE, YARBER

CITY COUNCIL AGENDA ITEM 10 POINT DATA SHEET June 16, 2017

DATE

POINTS		COMMENTS
1.	Brief Description/Purpose	Order authorizing the Mayor to execute Supplemental Agreement with Hemphill Construction Company, Inc for the City's Traffic Calming Project
2.	Public Policy Initiative 1. Youth & Education 2. Crime Prevention 3. Changes in City Government 4. Neighborhood Enhancement 5. Economic Development 6. Infrastructure and Transportation 7. Quality of Life	4. Neighborhood Enhancement 6 Infrastructure and Transportation 7 Quality of Life
3.	Who will be affected	Residents and motorists on residential streets.
4.	Benefits	Additional construction signage while the speed bumps are under construction.
5.	Schedule (beginning date)	Upon concurrence of MDOT
6.	Location: ▪ WARD ▪ CITYWIDE (yes or no) (area) ▪ Project limits if applicable	All 1. Pocahontas Ave north of Medgar Evers Blvd 2. Central St from Dalton St to Rose St 3. Dogwood Dr from Honeysuckle Ln to Meadowbrook Rd 4. Newman Ave 5. Castle Hill Dr from Joanne Dr to Dorgan St 6. Gardenia St 7. Marydale Dr from Smallwood St to Charleston Dr 8. Berwood Dr/Azalea Cir from Watkins Dr to Azalea Dr 9. Dewitt Ave from Bailey Ave to Pleasant Ave 10. Enoch St from Oak Park Dr to Summit St 11. Holmes Ave from Woodrow Wilson to Page 12. Brandon Ave 13. Valley St from Robinson St to First Ave 14. Wynndike Rd neighborhood 15. N Canton Club Cir 16. Woodfield Dr and Mossline Dr 17. Oakridge Dr from Old Canton to Meadowbrook 18. Plantation Blvd from Ridgewood to Fernwood 19. Ridgeway St from Northview to State 20. Winchester St from Old Canton to Ridgewood 21. River Thames Rd area (River Thames , Reddoch, Suffolk)
7.	Action implemented by: ▪ City Department <input checked="" type="checkbox"/> ▪ Consultant <input type="checkbox"/>	City of Jackson, Department of Public Works, Engineering Division
8.	COST	Increase of \$9,299.20. Original contract amount was \$341,589.20. New contract amount will be \$350,888.40.
9.	Source of Funding ▪ General Fund <input type="checkbox"/> ▪ Grant <input checked="" type="checkbox"/> ▪ Bond <input type="checkbox"/> ▪ Other <input type="checkbox"/>	FHWA Earmark 100% <u>216 44890 3150090 6485</u>
10.	EBO participation	ABE _____% WAIVER yes ___ no ___ N/A ___ AABE _____% WAIVER yes ___ no ___ N/A ___ WBE _____% WAIVER yes ___ no ___ N/A ___ HBE _____% WAIVER yes ___ no ___ N/A ___ NABE _____% WAIVER yes ___ no ___ N/A ___



MEMORANDUM

To: Mayor Tony Yarber

From: Jerriot Smash 
Interim Director

Date: June 16, 2017

Subject: Agenda Item for City Council Meeting

Attached you will find an item for the agenda authorizing the Mayor to execute supplemental agreement #1 to the contract with Hemphill Construction Company, Inc. for the traffic calming project.

During construction, the City and the contractor determine that additional construction signage was necessary to warn motorists about each under-construction bump. Specifically, the two strips that are milled before the asphalt is placed was catching motorists off-guard despite the presence of Bump or Dip signage at the start of each work zone. Since there was no pay item for additional construction signage, the contractor submitted a request for an additional pay item to cover the cost of 20 large Dip signs at \$29.06 per square foot for a total of \$9,299.20. Since the project is 100% federally funded, MDOT reviewed the request and determined that the cost and reasoning was reasonable and that there was sufficient remaining earmark funds to cover the added cost.

For the benefit of all, here is the list of streets under this contract. We are aware of some issues with some of the already-built bumps will have those addressed before the end of the project. There are no more federal funds available for extra or added streets.

1. Pocahontas Ave north of Medgar Evers Blvd
2. Central St (Dalton St to Rose St)
3. Dogwood Dr (Honeysuckle to Meadowbrook)
4. Newman Ave
5. Castle Hill Dr (Joanne Dr to Dorgan St)
6. Gardenia St
7. Marydale Dr (Smallwood St to Charleston Dr)
8. Berwood Dr/Azalea Cir (Watkins to Azalea)
9. Dewitt Ave (Bailey Ave to Pleasant Ave)
10. Enoch St (Oak Park Dr to Summit St)
11. Holmes Ave (Woodrow Wilson to Page)
12. Brandon Ave
13. Valley St from Robinson St to First Ave
14. Wynndike Rd neighborhood
15. N Canton Club Cir
16. Woodfield Dr and Mossline Dr
17. Oakridge Dr (Old Canton to Meadowbrook)
18. Plantation Blvd (Ridgewood to Fernwood)
19. Ridgeway St (Northview to State)
20. Winchester St (Old Canton to Ridgewood)
21. River Thames Rd, Reddoch, Suffolk

It is the recommendation of Public Works that the bid be accepted. If you have any questions or comments, please do not hesitate to call me at (601) 960-2091.

Office of the City Attorney

455 East Capitol Street
Post Office Box 2779
Jackson, Mississippi 39207-2779
Telephone: (601) 960-1799
Facsimile: (601) 960-1756

OFFICE OF THE CITY ATTORNEY

This ORDER AUTHORIZING THE MAYOR TO EXECUTE SUPPLEMENTAL AGREEMENT #1 TO THE CONTRACT OF HEMPHILL CONSTRUCTION COMPANY, INC. FOR THE TRAFFIC CALMING PROJECT, FEDERAL AID PROJECT NUMBER TCSP-0250-00(046)/103924, CITY PROJECT NUMBER 31500 (ALL WARDS) is legally sufficient for placement in NOVUS Agenda.



Monica D. Joiner, City Attorney

Nakesha Watkins, Legal Counsel 

DATE

ORDER ACCEPTING THE BID OF W.E. BLAIN & SONS, INC. FOR CONSTRUCTION OF TERRY ROAD RESURFACING PROJECT, FEDERAL AID PROJECT NUMBER STP-7286-00(003)/106995, CITY PROJECT NUMBER 14B4002, AND AUTHORIZING THE MAYOR TO EXECUTE A CONTRACT WITH SAID COMPANY SUBJECT TO THE CONCURRENCE OF THE MISSISSIPPI TRANSPORTATION COMMISSION (WARDS 6&7)

WHEREAS, the City of Jackson solicited sealed, competitive bids for the construction of the Terry Road Resurfacing Project; and

WHEREAS, two bids were submitted to the City Clerk on June 13th, 2017; and

WHEREAS, the bid of W.E. Blain & Sons, Inc. in the amount of \$1,529,354.65 was the lowest bid received; and

WHEREAS, the Public Works Department recommends that the governing authorities deem the bid of W.E. Blain & Sons, Inc. in the amount of \$1,529,354.65 for the Terry Road Resurfacing Project to be the lowest and best bid; and

WHEREAS, the awarding of the bid shall be subject to the concurrence of the Mississippi Transportation Commission; and

WHEREAS, during the life of the project, it will be necessary for the Mayor to execute various no-cost documents as part of the administration and construction of the project.

IT IS, THEREFORE, ORDERED that the bid of W.E. Blain & Sons, Inc. for the construction of the Terry Road Resurfacing Project, Federal Aid Project Number STP-7286-00(003)/106995, City Project Number 14B4002 in the amount of \$1,529,354.65, is accepted as the lowest and best bid.

IT IS FURTHER ORDERED that the Mayor is authorized to execute and the City Clerk is authorized to attest a contract with W.E. Blain & Sons, Inc. for the construction of the Terry Road Resurfacing Project.

IT IS FURTHER ORDERED that the Mayor be authorized to execute any and all no-cost item documents necessary for the administration and construction of the Terry Road Resurfacing Project and to submit the same to MDOT as needed.

SMASH, WILLIAMS, R. LEE, YARBER
CITY ATTORNEY
June 14, 2017

CITY COUNCIL AGENDA ITEM 10 POINT DATA SHEET June 15, 2017

DATE

OFFICE OF THE CITY ATTORNEY
JUNE 15 2017

POINTS		COMMENTS
1.	Brief Description/Purpose	Order authorizing the Mayor to execute a construction contract with W.E. Blain & Sons, Inc. for the Terry Road Resurfacing Project
2.	Public Policy Initiative <ol style="list-style-type: none"> 1. Youth & Education 2. Crime Prevention 3. Changes in City Government 4. Neighborhood Enhancement 5. Economic Development 6. Infrastructure and Transportation 7. Quality of Life 	<ol style="list-style-type: none"> 4. Neighborhood Enhancement 6 Infrastructure and Transportation 7 Quality of Life
3.	Who will be affected	Motorists and Pedestrians along Terry Rd from Cooper Rd to Stokes Robinson Rd
4.	Benefits	Street resurfacing, sidewalk improvements
5.	Schedule (beginning date)	Upon concurrence of MDOT
6.	Location: <ul style="list-style-type: none"> ▪ WARD ▪ CITYWIDE (yes or no) (area) ▪ Project limits if applicable 	Ward 6/7 (along Terry Rd from Cooper Rd to Stokes Robinson Rd)
7.	Action implemented by: <ul style="list-style-type: none"> ▪ City Department <input checked="" type="checkbox"/> ▪ Consultant <input type="checkbox"/> ▪ <input type="checkbox"/> 	City of Jackson, Department of Public Works, Engineering Division
8.	COST	\$1,529,354.65
9.	Source of Funding <ul style="list-style-type: none"> ▪ General Fund <input type="checkbox"/> ▪ Grant <input checked="" type="checkbox"/> ▪ Bond <input type="checkbox"/> ▪ Other <input type="checkbox"/> 	STP/MPO MAP-21 Pavement Preservation Funds (50% up to \$650,000) Acct # 213 45190 14B4002 601 6485
10.	EBO participation	ABE _____% WAIVER yes ___ no ___ N/A _____ AABE _____% WAIVER yes ___ no ___ N/A _____ WBE _____% WAIVER yes ___ no ___ N/A _____ HBE _____% WAIVER yes ___ no ___ N/A _____ NABE _____% WAIVER yes ___ no ___ N/A _____

Department of Public Works



200 South President Street
Post Office Box 17
Jackson, Mississippi 39205-0017

Tony Yarber
Mayor of the City of Jackson

MEMORANDUM

To: Mayor Tony Yarber

From: Jerriot Smash 
Interim Director

Date: June 15, 2017

Subject: Agenda Item for City Council Meeting

Attached you will find an item for the agenda authorizing the Mayor to execute a construction contract with W.E. Blain & Sons, Inc. for the Terry Road Resurfacing Project.

The City of Jackson applied for and received a competitive grant for \$650,000.00 in MAP-21 funds through the Jackson MPO for resurfacing Terry Rd from Cooper Rd south of Stokes Robinson Rd at the end of the 4-lane section of Terry Rd. The project will resurface the street as well as make ADA improvements to the existing sidewalks and fill in a one block gap in the sidewalk near Dona Ave. The City open sealed bids on June 13, 2017, and the lower of the two bids received was from W.E. Blain & Sons, Inc. in the amount of \$1,529,354.65.

It is the recommendation of Public Works that the bid be accepted. If you have any questions or comments, please do not hesitate to call me at (601) 960-2091.

City of Jackson STP-7286-00(003)LPA / 106995-701000 Terry Road Bid Tabulations 6/13/17

Item			Estimate		Blain		APAC		
PAY ITEM NO.	PLAN QUANT	UNIT	DESCRIPTION	UNIT PRICE	ITEM TOTAL	UNIT PRICE	ITEM TOTAL	UNIT PRICE	ITEM TOTAL
202-B006	1,844	SY	Removal of Asphalt Pavement, Failed Areas	\$9.00	\$16,596	\$8.50	\$15,674	\$8.50	\$15,674
202-B018	387	SY	Removal of Concrete Driveways, All Depths	\$16.00	\$6,192	\$26.15	\$10,120	\$26.15	\$10,120
202-B035	2,019	SY	Removal of Concrete Sidewalk	\$11.50	\$23,219	\$17.75	\$35,837	\$17.75	\$35,837
202-B038	2,127	LF	Removal of Curb, All Types	\$10.00	\$21,270	\$17.75	\$37,754	\$17.75	\$37,754
202-B054	953	LF	Removal of Guard Rail Only	\$6.00	\$5,718	\$6.00	\$5,718	\$6.00	\$5,718
202-B070	4	EA	Removal of Sign Including Post and Footing	\$50.00	\$200	\$50.00	\$200	\$50.00	\$200
202-B086	149	EA	Removal of Guard Post	\$16.00	\$2,384	\$16.00	\$2,384	\$16.00	\$2,384
202-B099	1	EA	Removal of Existing Light and Foundation	\$2,200.00	\$2,200	\$2,200.00	\$2,200	\$2,200.00	\$2,200
203-A003	377	CY	Unclassified Excavation, FM, AH	\$40.00	\$15,080	\$8.75	\$3,299	\$8.75	\$3,299
907-216-A001	1,049	SY	Solid Sodding	\$6.50	\$6,819	\$7.00	\$7,343	\$7.00	\$7,343
219-A001	22.6	KGAL	Watering	\$20.00	\$452	\$522.50	\$11,809	\$522.50	\$11,809
907-304-F002	1,738	TON	Size 610 Crushed Stone Base	\$60.00	\$104,280	\$68.00	\$118,184	\$68.00	\$118,184
907-403-A023	4,304	TON	Asphalt Pavement, 12.5mm, MT	\$76.00	\$327,104	\$90.00	\$387,360	\$90.00	\$387,360
907-403-B017	4,109	TON	Asphalt Pavement, 12.5mm, MT, Levelling	\$76.00	\$312,284	\$91.00	\$373,919	\$91.00	\$373,919
907-406-A001	37,164	SY	Cold Milling of Bituminous Pavement, All Depths	\$2.75	\$102,201	\$4.00	\$148,656	\$4.00	\$148,656
907-407-A001	3,913	GAL	Asphalt for Tack Coat	\$2.75	\$10,761	\$3.00	\$11,739	\$3.00	\$11,739
503-B001	370	LF	Saw Cut, Longitudinal Joints	\$11.00	\$4,070	\$18.80	\$6,956	\$18.80	\$6,956
606-B007	924	LF	Guard Rail, Class A, Type 1, 'W' Beam, Metal Post	\$22.00	\$20,328	\$22.00	\$20,328	\$22.00	\$20,328
606-C002	5	EA	Guard Rail, Cable Anchor Type 1, Metal Post	\$850.00	\$4,250	\$850.00	\$4,250	\$850.00	\$4,250
608-B001	2,185	SY	Concrete Sidewalk, With Reinforcement	\$44.00	\$96,140	\$27.40	\$51,841	\$27.40	\$51,841
609-B001	1,892	LF	Concrete Curb, Header	\$25.00	\$47,300	\$33.00	\$55,044	\$33.00	\$55,044
609-D008	1,668	LF	Combination Concrete Curb and Gutter Type 3A	\$26.00	\$43,408	\$26.00	\$43,408	\$26.00	\$43,408
907-611-PP003	249	SF	Detectable Warning, Per Plans	\$1,000.00	\$249,000	\$80.00	\$19,920	\$80.00	\$19,920
613-A002	6	EA	Adjustment of Castings, Gratings and Utility	\$80.00	\$480	\$80.00	\$480	\$80.00	\$480
614-B001	120	SY	Concrete Driveway, With Reinforcement	\$61,000.00	\$7,320,000	\$185,000.00	\$22,200,000	\$185,000.00	\$22,200,000
907-618-A001	1	LS	Maintenance of Traffic	\$10.00	\$10	\$10.00	\$10	\$10.00	\$10
907-618-B001	1	SF	Additional Construction Signs	\$0.25	\$0.25	\$0.25	\$0.25	\$0.25	\$0.25
619-A1003	8,464	LF	Temporary Traffic Stripe, Continuous White, Paint	\$0.25	\$2,116	\$0.25	\$2,116	\$0.25	\$2,116
619-A2001	13,182	LF	Temporary Traffic Stripe, Continuous Yellow, Paint	\$0.25	\$3,296	\$0.25	\$3,296	\$0.25	\$3,296
619-A3001	10,658	LF	Temporary Traffic Stripe, Skip White, Paint	\$0.25	\$2,665	\$0.25	\$2,665	\$0.25	\$2,665
619-A4001	450	LF	Temporary Traffic Stripe, Skip Yellow, Paint	\$0.25	\$113	\$0.25	\$113	\$0.25	\$113
620-A001	1	LS	Mobilization	\$130,000.00	\$130,000	\$130,000.00	\$130,000	\$130,000.00	\$130,000
907-626-A004	10,472	LF	6" Thermoplastic Traffic Stripe, Skip White	\$0.30	\$3,142	\$0.30	\$3,142	\$0.30	\$3,142
907-626-B003	6,817	LF	6" Thermoplastic Traffic Stripe, Continuous White	\$0.45	\$3,068	\$0.45	\$3,068	\$0.45	\$3,068
907-626-D004	450	LF	6" Thermoplastic Traffic Stripe, Skip Yellow	\$0.30	\$135	\$0.30	\$135	\$0.30	\$135
907-626-E003	8,043	LF	6" Thermoplastic Traffic Stripe, Continuous Yellow	\$0.45	\$3,619	\$0.45	\$3,619	\$0.45	\$3,619
907-626-G004	9,198	LF	Thermoplastic Detail Stripe, White	\$0.65	\$5,979	\$0.65	\$5,979	\$0.65	\$5,979
907-626-G005	5,432	LF	Thermoplastic Detail Stripe, Yellow	\$0.65	\$3,531	\$0.65	\$3,531	\$0.65	\$3,531
907-626-H004	5,002	LF	Thermoplastic Legend, White	\$1.40	\$7,003	\$1.40	\$7,003	\$1.40	\$7,003
907-626-H005	606	SF	Thermoplastic Legend, White	\$4.00	\$2,424	\$4.00	\$2,424	\$4.00	\$2,424
627-D001	312	EA	Red-Clear Reflective Raised Markers	\$3.50	\$1,092	\$3.50	\$1,092	\$3.50	\$1,092
627-E001	645	EA	Two-Way Yellow Reflective Raised Markers	\$3.50	\$2,258	\$3.50	\$2,258	\$3.50	\$2,258
630-A001	124	EA	One-Way Clear Reflective Raised Markers	\$3.50	\$434	\$3.50	\$434	\$3.50	\$434
630-C003	30	SF	Standard Roadside Signs, Sheet Aluminum, 0.080"	\$70.00	\$2,100	\$70.00	\$2,100	\$70.00	\$2,100
907-630-O003	52	LF	Steel U-Section Posts, 3.0 Lb/Ft	\$11.00	\$572	\$11.00	\$572	\$11.00	\$572
907-631-A001	4	EA	Remove and Reset Sign, All Sizes	\$250.00	\$1,000	\$250.00	\$1,000	\$250.00	\$1,000
635-A001	10	CY	Flowable Fill, Excavatable	\$350.00	\$3,500	\$350.00	\$3,500	\$350.00	\$3,500
815-A001	7,440	LF	Vehicle Loop Assemblies	\$13.25	\$98,580	\$13.25	\$98,580	\$13.25	\$98,580
	3	SY	Loose Riprap, Size 100	\$200.00	\$600	\$200.00	\$600	\$200.00	\$600
Subtotal				\$1,248,945.80	\$1,529,354.65	\$1,956,341.35	\$1,956,341.35		

57%

22%

Difference

Certified Correct: _____
Date: 6/14/17

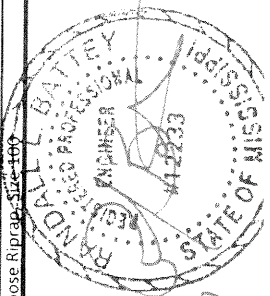

Office of the City Attorney

455 East Capitol Street
Post Office Box 2779
Jackson, Mississippi 39207-2779
Telephone: (601) 960-1799
Facsimile: (601) 960-1756

OFFICE OF THE CITY ATTORNEY

This **ORDER ACCEPTING THE BID OF W. E. BLAIN & SONS, INC. FOR CONSTRUCTION OF TERRY ROAD RESURFACING PROJECT, FEDERAL AID PROJECT NUMBER STP-7286-00(003)/106995, CITY PROJECT NUMBER 14B4002, AND AUTHORIZING THE MAYOR TO EXECUTE A CONTRACT WITH SAID COMPANY SUBJECT TO THE CONCURRENCE OF THE MISSISSIPPI TRANSPORTATION COMMISSION (WARD 6 & 7)** is legally sufficient for placement in NOVUS Agenda.



Monica D. Joiner, *City Attorney*

Nakesha Watkins, *Legal Counsel* 

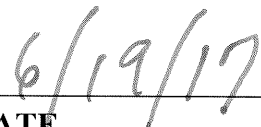

DATE

OFFICE OF THE CITY ATTORNEY
June 19, 2017
NW

ORDER RATIFYING A CONTRACT WITH UTILITY CONSTRUCTORS, INC., FOR THE WEST STREET EMERGENCY SEWER REPAIR CITY PROJECT NO. 17B0502.701 (WARD 7)

WHEREAS, the Department of Public Works discovered a collapsed sewer main on West Street damaged by the April 2, 2017 rainfall storm event causing raw sewer to discharge into local drainage inlets; and

WHEREAS, the Mayor declared an emergency, under Section 31-7-13(k) of the Mississippi Code of 1972, as amended, due the collapsed sewer main discharging raw sewer into local drainage inlets is a violation of the Clean Water Act; and

WHEREAS, the City of Jackson solicited quotes from three contractors: Hemphill Construction Company, Inc., and Delta Constructors, Inc., and Utility Constructors, Inc., to repair the sewer main; and

WHEREAS, the City of Jackson accepted lowest and best quote from Utility Constructors, Inc., in amount of \$699,246.00; and

WHEREAS, a final field inspection was held by the Department of Public Works and recommends acceptance of the project; and

WHEREAS, the original quote amount was for \$699,246.00, and the decreased amount is \$675,718.35; and

WHEREAS, the Department of Public Works recommends final payment in the amount of \$675,718.35.00 to Utility Constructors, Inc.; and

WHEREAS, the bonding company Sure Tec Insurance Company, Attorney-in-fact, surety on performance of the said contract, has authorized release and payment of all money due under said contract; and

IT IS, THEREFORE, ORDERED that the contract with Utility Constructors, Inc., for emergency repair work in the amount of \$675,718.35 is ratified.

IT IS FURTHER ORDERED that the City make final payment in the amount of \$675,718.35 to Utility Constructors, Inc., and release all securities held to Utility Constructors, Inc., for all the work completed and materials furnished under this contract and that the City Clerk publish the Notice of Completion of the West Street Emergency Sewer Repair, City Project No. 17B0502.701.

ITEM #

17

DATE:

BY:

SMASH, WILLIAMS, YARBER

CITY COUNCIL AGENDA ITEM 10 POINT DATA SHEET
June 12, 2017

OFFICE OF THE CITY ATTORNEY
 Date: 6/12/17

P O I N T S		C O M M E N T S																																													
1.	Brief Description/Purpose	ORDER RATIFYING A CONTRACT WITH UTILITY CONSTRUCTORS, INC., FOR THE WEST STREET EMERGENCY SEWER REPAIR, CITY PROJECT NO. 17B0502.701 (WARD 7)																																													
2.	Public Policy Initiative 1. Youth & Education 2. Crime Prevention 3. Changes in City Government 4. Neighborhood Enhancement 5. Economic Development 6. Infrastructure and Transportation 7. Quality of Life	This item addresses Items 5, 6, and 7																																													
3.	Who will be affected	All residents of the City of Jackson																																													
4.	Benefits	Sewer Infrastructure																																													
5.	Schedule (beginning date)	This project is complete																																													
6.	Location: ■ WARD ■ CITYWIDE (yes or no) (area) ■ Project limits if applicable	This project is located in Ward 7																																													
7.	Action implemented by: ■ City Department <input checked="" type="checkbox"/> ■ Consultant <input type="checkbox"/>	This project was implemented by the Engineering Division.																																													
8.	COST	Final Cost: \$675,718.35																																													
9.	Source of Funding ■ General Fund <input type="checkbox"/> ■ Grant <input type="checkbox"/> ■ Bond <input type="checkbox"/> ■ Other <input checked="" type="checkbox"/>	032-52290-7B0502-701-6485																																													
10.	EBO participation	<table border="0"> <tr> <td>ABE</td> <td>_____ %</td> <td>WAIVER</td> <td>yes</td> <td>___</td> <td>no</td> <td>___</td> <td>N/A</td> <td>___</td> </tr> <tr> <td>AABE</td> <td>_____ %</td> <td>WAIVER</td> <td>yes</td> <td>___</td> <td>no</td> <td>___</td> <td>N/A</td> <td>___</td> </tr> <tr> <td>WBE</td> <td>_____ %</td> <td>WAIVER</td> <td>yes</td> <td>___</td> <td>no</td> <td>___</td> <td>N/A</td> <td>___</td> </tr> <tr> <td>HBE</td> <td>_____ %</td> <td>WAIVER</td> <td>yes</td> <td>___</td> <td>no</td> <td>___</td> <td>N/A</td> <td>___</td> </tr> <tr> <td>NABE</td> <td>_____ %</td> <td>WAIVER</td> <td>yes</td> <td>___</td> <td>no</td> <td>___</td> <td>N/A</td> <td>___</td> </tr> </table>	ABE	_____ %	WAIVER	yes	___	no	___	N/A	___	AABE	_____ %	WAIVER	yes	___	no	___	N/A	___	WBE	_____ %	WAIVER	yes	___	no	___	N/A	___	HBE	_____ %	WAIVER	yes	___	no	___	N/A	___	NABE	_____ %	WAIVER	yes	___	no	___	N/A	___
ABE	_____ %	WAIVER	yes	___	no	___	N/A	___																																							
AABE	_____ %	WAIVER	yes	___	no	___	N/A	___																																							
WBE	_____ %	WAIVER	yes	___	no	___	N/A	___																																							
HBE	_____ %	WAIVER	yes	___	no	___	N/A	___																																							
NABE	_____ %	WAIVER	yes	___	no	___	N/A	___																																							



City of Jackson
Department of Public Works

Council Agenda Item Memorandum

To: Tony T. Yarber
From: Jerriot Smash, Interim Director *JR*
Date: June 12, 2017

Agenda Item: West Street Emergency Sewer Repair
Item #:
Council Meeting: Regular Council Meeting, June 27, 2017
Consultant/Contractor: N/A
EBO Compliance Details:

Purpose: Sewer Infrastructure Repair
Cost: Final Cost: \$675,718.35
Project/Contract Type: Water & Sewer Repair
Funding Source: Fund 32 Water/Sewer Revenue Bond
Schedule/Time: Completed
DPW Manager: Charles Williams Jr., PE, PhD/William "Bill" Miley

Background:

Attached, you will find an item for the City Council Agenda requesting to ratify a contract with Utility Constructors, Inc., for the West Street Emergency Sewer Repair.

The emergency was required due to a sewer main collapse located on West Street damaged from the April 2, 2017 rainfall storm event. The sewer main collapse has caused raw sewer to discharge into local drainage inlets violating the Clean Water Act. The Mayor declared an emergency based on the storm event to allow solicitation of quotes from contractors to repair the sewer main. The work was done in accordance with the specifications, and the Public Works recommends approval of final payment to Utility Constructors, Inc. If you have any questions, or require additional information, please do not hesitate to contact this office at (601) 960-2091.



**City of Jackson
Department of Public Works**

Talking Points:

West Street Emergency Sewer Repair

- The City of Jackson maintenance crews discovered a collapsed sewer main resulting from the April 2, 2017 rainfall storm event.
- The Mayor declared an emergency to authorize the repair of the sewer main.
- The emergency declaration allowed for the repair of the sanitary sewer main to stay within the compliance of the Clean Water Act.
- Utility Constructors, Inc., provided the Public Works Department with lowest and best quote.
- The work has been completed, and inspected by the Public Works Department.
- The Public Works Department recommends final payment to Utility Constructors, Inc.

MEMORANDUM

Department of Public Works
(601) 960-2090



TO: Jerriot Smash., Interim Director
Department of Public Works

FROM: Charles E. Williams Jr., P.E., PhD, Engineering Manager *cw*
William Miley, Utilities Manager *w m*
Department of Public Works

CC: Erica, Thomas, Public Works Fiscal Officer

DATE: April 7, 2017

RE: April 2, 2017 Rainfall Storm Event

The City of Jackson received over 5" of rainfall within a short period of time causing significant damage to the City's infrastructure systems. The damages reported was not limited to water mains, sewer mains, bridge structures, and storm drainage systems. The Department of Public Works maintenance crews have limited personnel to handle all of the required repairs. The repairs needed are critical to staying within compliance regarding the Clean Water Act and the Consent Decree. It is also critical in stabilizing the transportation and drainage systems.

The City does not have the personnel or equipment to adequately address the necessary repairs to ensure welfare and safety of the Public. Because of the imminent threat to public health and safety, I recommend that the City enter into a replacement contract as provided for in Section 31-7-13(k) of the Mississippi Code Annotated of 1972.

**DECLARATION OF EMERGENCY
TO INVOKE EMERGENCY REPAIR CONTRACT PROCEDURE**

I. REQUEST

The City of Jackson received over 5" of rainfall within a short period of time on April 2, 2017. The intensity of the rainfall duration caused significant damage to the City of Jackson's water mains, sanitary sewer mains, bridge structures, and storm drainage systems. The urgency to repair the damaged infrastructure is critical to staying within compliance with local and federal agencies who govern the Clean Water Act. The City of Jackson has limited maintenance crews to handle all to the repairs required to stabilize the City's Infrastructure systems.

Accordingly, I request that you declare this situation an "emergency" as that term is defined in Section 31-7-1 of the Mississippi Code Annotated of 1972, as amended, and authorize the City to enter into contracts with local contractor to repair water mains, sewer mains, bridge structures, and storm drainage systems, to Section 31-7-13 (k) of the Mississippi Code Annotated of 1972, as amended, and to execute and accept such other documents and instruments as necessary to accomplish said repairs.

I have provided a memo as background information to assist in your determination that an emergency exists. I have also obtained the review and approval of the Legal Department and Administration Department, as evidenced by the signatures below.

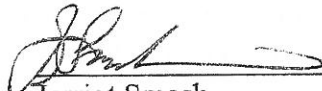

Jerriot Smash
Interim Director of Public Works

10. APR 17

DATE

II. REVIEWED AND APPROVED

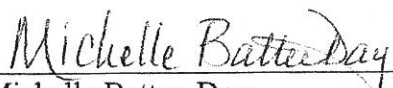

Michelle Battee-Day
Interim Director of Finance Administration

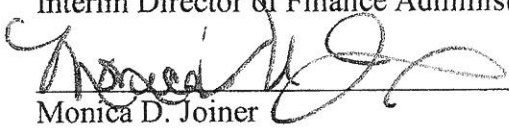

Monica D. Joiner
City Attorney

4/10/17

DATE

4/11/17

DATE

III. DECLARATION OF EMERGENCY

I hereby determine that the rainfall event on April 2, 2017 has caused significant damage to the City of Jackson's water mains, sanitary sewer mains, bridge structures, and storm drainage systems throughout the City of Jackson. This, in my judgment, constitutes an emergency as that term is defined under Section of 31-7-1, so that the delay incident to giving opportunity for competitive bidding would be detrimental to the interest of the City of Jackson, Mississippi and that the City is authorized to enter into contracts to repair the infrastructure needs based on the April 2, 2017 rainfall storm event , pursuant to Section 31-7-13 (k) of the Mississippi Code Annotated of 1972, as amended, and execute and accept such other documents and instruments as necessary to accomplish said repair.

Accordingly, this request is approved.

Tony T. Yarber
Mayor

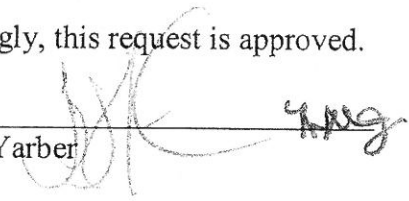

4.13.17
DATE

Office of the City Attorney

455 East Capitol Street
Post Office Box 2779
Jackson, Mississippi 39207-2779
Telephone: (601) 960-1799
Facsimile: (601) 960-1756

OFFICE OF THE CITY ATTORNEY

This ORDER RATIFYING A CONTRACT WITH UTILITY CONSTRUCTORS INC.,
FOR THE WEST STREET EMERGENCY SEWER REPAIR, CITY PROJECT NO.
17B0502.701 (WARD 7) is legally sufficient for placement in NOVUS Agenda.



Monica D. Joiner, *City Attorney*

Nakesha Watkins, *Legal Counsel* NW

6/19/17

DATE

ORDER AUTHORIZING THE MAYOR TO EXECUTE A PRELIMINARY ENGINEERING SERVICES CONTRACT WITH MICHAEL BAKER INTERNATIONAL, FOR THE WOODROW WILSON AVENUE RESURFACING FROM MILL STREET TO I-55, FEDERAL AID PROJECT NO. STP-7281-00(004) LPA/107549-701000, CITY PROJECT NO. 17B4003.701 (WARDS 7)

WHEREAS, the City of Jackson made application for and received FAST Act federal transportation funds through the Jackson MPO for the Woodrow Wilson Avenue Resurfacing from Mill Street to I-55; and

WHEREAS, the City of Jackson selected Michael Baker International Inc, a local Civil Engineering firm from its solicited statement of qualifications to perform necessary preliminary engineering services for the project; and

WHEREAS, Michael Baker International, Inc., has provided a cost proposal of \$180,600.00 to provide preliminary engineering services for the project.

IT IS THEREFORE ORDERED that the Mayor is authorized to execute a preliminary engineering services contract with Michael Baker International, Inc., for the Woodrow Wilson Avenue Resurfacing from Mill Street to I-55, Federal Aid Project No. STP-7281-00(004) LPA/107549-701000, City Project No. 17B4003.701, for an amount not to exceed \$180,600.00.

Item#: 18 _____

Agenda: _____

By: Smash, Williams, R. Lee, Yarber

THE CITY ATTORNEY
Date: 11-19-2011
[Signature]

CITY COUNCIL AGENDA ITEM 10 POINT DATA SHEET

June 15, 2017

DATE

OFFICE OF THE CITY ATTORNEY
 June 15, 2017

POINTS		COMMENTS
1.	Brief Description	ORDER AUTHORIZING THE MAYOR TO EXECUTE A PRELIMINARY ENGINEERING SERVICES CONTRACT WITH MICHAEL BAKER INTERNATIONAL, FOR THE WOODROW WILSON AVENUE RESURFACING FROM MILL STREET TO I-55, FEDERAL AID PROJECT NO. STP-7281-00(004) LPA/107549-701000, CITY PROJECT NO. 17B4003.701 (WARDS 7)
2.	Public Policy Initiative <ol style="list-style-type: none"> 1. Youth & Education 2. Crime Prevention 3. Changes in City Government 4. Neighborhood Enhancement 5. Economic Development 6. Infrastructure and Transportation 7. Quality of Life 	5, 6, 7
3.	Who will be affected	Residents, businesses, and motorists on Woodrow Wilson Avenue
4.	Benefits	Provide engineering services for the Woodrow Wilson Avenue Resurfacing Project.
5.	Schedule (beginning date)	After City Council approval.
6.	Location: <ul style="list-style-type: none"> ▪ WARD ▪ CITYWIDE (yes or no) (area) ▪ Project limits if applicable 	Woodrow Wilson Avenue Ward 7
7.	Action implemented by: <ul style="list-style-type: none"> ▪ City Department <input checked="" type="checkbox"/> ▪ Consultant <input type="checkbox"/> 	Public Works Department, Engineering Division
8.	COST	Not to exceed \$180,600.00
9.	Source of Funding <ul style="list-style-type: none"> ▪ General Fund <input type="checkbox"/> ▪ Grant <input type="checkbox"/> ▪ Bond <input type="checkbox"/> ▪ Other <input checked="" type="checkbox"/> 	Municipal Sales Tax 173-45135-7B4003-701-6413
10.	EBO participation	ABE _____ % WAIVER yes ___ no ___ N/A _____ AABE _____ % WAIVER yes ___ no ___ N/A _____ WBE _____ % WAIVER yes ___ no ___ N/A _____ HBE _____ % WAIVER yes ___ no ___ N/A _____ NABE _____ % WAIVER yes ___ no ___ N/A _____



**City of Jackson
Department of Public Works**

Council Agenda Item Memorandum

To: Tony T. Yarber
From: Jerriot Smash, Interim Director 
Date: June 15, 2017, 2017

Agenda Item: Engineering Services Agreement with Michael Baker International, Inc.
Item #:
Council Meeting: Regular Council Meeting, June 27, 2017
Consultant/Contractor: Michael Baker International, Inc.

EBO Compliance Details:

- ABE: 0%
- AABE: 11.39%
- HBE: 0%
- NABE: 0%
- FBE: 0%

Purpose: Design Engineering Services for the Woodrow Wilson Avenue Resurfacing
Cost: \$180,600.00
Project/Contract Type: Design Engineering Services
Funding Source: Fund 173
Schedule/Time: June 2017
DPW Manager: Charles Williams Jr., PE, PhD

Background:

Attached, you will find an item for the City Council Agenda to authorize the Mayor to enter into an agreement with Michael Baker International, Inc., for the Woodrow Wilson Avenue Resurfacing from Mill Street to I-55.

The City of Jackson was awarded Federal FAST Act funding for road preservation work.

Michael Baker International, Inc., a local metro Jackson design engineering firm was selected to perform design engineering for the resurfacing work on Woodrow Wilson Avenue.



**City of Jackson
Department of Public Works**

It is the recommendation of this office that the Mayor is authorized to execute an engineering service agreement with Michael Baker International, Inc., in an amount of not exceeding \$180,600.00. If you have any questions, or require additional information, please do not hesitate to contact this office at (601) 960-2091.

Talking Points:

Woodrow Wilson Avenue Resurfacing

- The City was awarded FAST ACT funds to help resurface roads within the Jackson Corporate Limits.
- The City selected Michael Baker International, Inc., from its solicited statement of qualifications for professional services.
- Michael Baker International, Inc., has provided a cost proposal not to exceed \$180,600.00.

Office of the City Attorney

455 East Capitol Street
Post Office Box 2779
Jackson, Mississippi 39207-2779
Telephone: (601) 960-1799
Facsimile: (601) 960-1756

OFFICE OF THE CITY ATTORNEY

OFFICE OF THE CITY ATTORNEY
June 19, 2017
N.W.

This ORDER AUTHORIZING THE MAYOR TO EXECUTE A PRELIMINARY ENGINEERING SERVICES CONTRACT WITH MICHAEL BAKER INTERNATIONAL, FOR THE WOODROW WILSON AVENUE RESURFACING FROM MILL STREET TO I-55, FEDERAL AID PROJECT NO. STP-7281-00(004) LPA/107549-701000, CITY PROJECT NO. 17B4003.701 (WARDS 7) is legally sufficient for placement in NOVUS Agenda.



Monica D. Joiner, City Attorney

Nakesha Watkins, Legal Counsel 

6/19/17

DATE

ORDER AUTHORIZING THE MAYOR TO EXECUTE A PRELIMINARY ENGINEERING SERVICES CONTRACT WITH STANTEC CONSULTING SERVICES, INC., FOR THE MCDOWELL ROAD OVER CANEY CREEK BRIDGE REPLACEMENT, FEDERAL AID PROJECT NO. STP-8280-00(003) LPA/107540-701000, CITY PROJECT NO. 17B4502.901 (WARDS 5&6)

WHEREAS, the City of Jackson made application for and received FAST Act federal transportation funds through the Jackson MPO for the McDowell Road over Caney Creek Bridge Replacement; and

WHEREAS, the City of Jackson selected Stantec Consulting Services, Inc., a local Civil Engineering firm from its solicited statement of qualifications to perform necessary preliminary engineering services for the project; and

WHEREAS, Stantec Consulting Services, Inc., has provided a cost proposal of \$242,000.00 to provide preliminary engineering services for the project.

IT IS THEREFORE ORDERED that the Mayor is authorized to execute a preliminary engineering services contract with Stantec Consulting Services, Inc., for the McDowell Road over Caney Creek Bridge Replacement, Federal Aid Project No. STP-8280-00(003) LPA/107540-701000, City Project No. 17B4502.901, for an amount not to exceed \$242,000.00.

Item#: 19

Agenda: _____

By: Smash, Williams, R. Lee, Yarber

CITY COUNCIL AGENDA ITEM 10 POINT DATA SHEET

June 15, 2017

DATE: *JUN 15 2017*

POINTS		COMMENTS
1.	Brief Description	ORDER AUTHORIZING THE MAYOR TO EXECUTE A PRELIMINARY ENGINEERING SERVICES CONTRACT WITH STANTEC CONSULTING SERVICES, INC., FOR THE MCDOWELL ROAD OVER CANEY CREEK BRIDGE REPLACEMENT, FEDERAL AID PROJECT NO. STP-8280-00(003) LPA/107540-701000, CITY PROJECT NO. 17B4502.901 (WARDS 5&6)
2.	Public Policy Initiative 1. Youth & Education 2. Crime Prevention 3. Changes in City Government 4. Neighborhood Enhancement 5. Economic Development 6. Infrastructure and Transportation 7. Quality of Life	5, 6, 7
3.	Who will be affected	Residents, businesses, and motorists on McDowell Road
4.	Benefits	Provide engineering services for the McDowell Road Bridge Replacement
5.	Schedule (beginning date)	After City Council approval.
6.	Location: ▪ WARD ▪ CITYWIDE (yes or no) (area) ▪ Project limits if applicable	McDowell Road Wards 5 & 6
7.	Action implemented by: ▪ City Department <input checked="" type="checkbox"/> ▪ Consultant <input type="checkbox"/>	Public Works Department, Engineering Division
8.	COST	Not to exceed \$242,000.00
9.	Source of Funding ▪ General Fund <input type="checkbox"/> ▪ Grant <input type="checkbox"/> ▪ Bond <input type="checkbox"/> ▪ Other <input checked="" type="checkbox"/>	Municipal Sales Tax 173-45135-7B4502-901-6413
10.	EBO participation	ABE _____ % WAIVER yes ___ no ___ N/A _____ AABE _____ % WAIVER yes ___ no ___ N/A _____ WBE _____ % WAIVER yes ___ no ___ N/A _____ HBE _____ % WAIVER yes ___ no ___ N/A _____ NABE _____ % WAIVER yes ___ no ___ N/A _____



City of Jackson
Department of Public Works

Council Agenda Item Memorandum

To: Tony T. Yarber

From: Jerriot Smash, Interim Director 

Date: June 15, 2017

Agenda Item: Engineering Services Agreement with Stantec Consulting Services, Inc
Item #:
Council Meeting: Regular Council Meeting, June 27, 2017
Consultant/Contractor: Crown Engineering

EBO Compliance Details:

- ABE: 0%
- AABE: 8.27%
- HBE: 0%
- NABE: 0%
- FBE: 0%

Purpose: Design Engineering Services for the McDowell Road Bridge Replacement
Cost: \$242,000.00
Project/Contract Type: Design Engineering Services
Funding Source: Fund 173
Schedule/Time: June 2017
DPW Manager: Charles Williams Jr., PE, PhD

Background:

Attached, you will find an item for the City Council Agenda to authorize the Mayor to enter into an agreement with Stantec Consulting Services, Inc., for the McDowell Road Bridge Replacement.

The City of Jackson was awarded Federal FAST Act funding for bridge replacement and rehabilitation work.

Stantec Consulting Services, Inc., a local Jackson design engineering firm was selected to perform design engineering for the bridge replacement project.



**City of Jackson
Department of Public Works**

It is the recommendation of this office that the Mayor is authorized to execute an engineering service agreement with Stantec Consulting Services, Inc., in an amount of not exceeding \$242,000.00. If you have any questions, or require additional information, please do not hesitate to contact this office at (601) 960-2091.

Talking Points:

McDowell Road Bridge Replacement

- The City was awarded FAST ACT funds to help repair and replace bridge structures within the Jackson Corporate Limits.
- The City selected Stantec Consulting Services from its solicited statement of qualifications for professional services.
- Crown Engineering has provided a cost proposal not to exceed \$242,000.00.

Office of the City Attorney

455 East Capitol Street
Post Office Box 2779
Jackson, Mississippi 39207-2779
Telephone: (601) 960-1799
Facsimile: (601) 960-1756

OFFICE OF THE CITY ATTORNEY

This **ORDER AUTHORIZING THE MAYOR TO EXECUTE A PRELIMINARY ENGINEERING SERVICE CONTRACT WITH STANTEC CONSULTING SERVICES, INC., FOR THE MCDOWELL ROAD OVER CANEY CREEK BRIDGE REPLACEMENT, FEDERAL AID PROJECT NO. STP-8280-00(003) LPA/1075470-701000, CITY PROJECT NO. 17B4502.901 (WARDS 5 & 6)** is legally sufficient for placement in NOVUS Agenda.



Monica D. Joiner, *City Attorney*

Nakesha Watkins, *Legal Counsel* 

DATE

ORDER AUTHORIZING THE PAYMENT TO EMPIRE TRUCK SALES LLC, FOR THE REPAIR OF VACTOR COMBINATION SEWER CLEANER TRUCK

OFFICE OF THE CITY ATTORNEY
June 16, 2017
RMO

WHEREAS, the exhaust emission system and fuel injectors failed which resulted in internal engine failure which made it necessary to rebuild the engine.

WHEREAS, the Sewer Division had a Vactor Combination Sewer Cleaner Truck repaired At Empire Truck Sales for \$35,835.86; and

WHEREAS, the repair of the equipment was necessary to maintain the City Sewer System and comply with the City's MDEQ Requirements; and

WHEREAS, Empire Truck Sales, LLC has submitted outstanding invoices to the City for the repair of a Vactor Combination Sewer Cleaner Truck for Payment totaling \$35,835.86.

IT IS, THEREFORE ORDERED that the sum of \$35,835.86 be paid to Empire Truck Sales, LLC for the repair of Vactor Combination Sewer Cleaner Truck.

CITY COUNCIL AGENDA ITEM 10 POINT DATA SHEET

January 17, 2017

OFFICE OF THE CITY ATTORNEY
 June 16, 2017
 JMW

POINTS		COMMENTS
1.	Brief Description	Order authorizing the payment to Empire Truck Sales LLC, for the repair of the Vactor Combination Sewer Cleaner Truck.
2.	Public Policy Initiative 1. Youth & Education 2. Crime Prevention 3. Changes in City Government 4. Neighborhood Enhancement 5. Economic Development 6. Infrastructure and Transportation 7. Quality of Life	5,6,7
3.	Who will be affected	City of Jackson's Certificated Area Sewer Customers
4.	Benefits	The repair of the equipment was necessary to maintain the City Sewer System and comply with the City's MDEQ Requirements
5.	Schedule (beginning date)	Upon Approval
6.	Location: ■ WARD ■ CITYWIDE (yes or no) (area) ■ Project limits if applicable	Citywide
7.	Action implemented by: ■ City Department <input checked="" type="checkbox"/> ■ Consultant <input type="checkbox"/>	Department of Public Works, Water/Sewer Division
8.	COST	\$ 35,835.86
9.	Source of Funding ■ General Fund <input type="checkbox"/> ■ Grant <input type="checkbox"/> ■ Bond <input type="checkbox"/> ■ Other <input checked="" type="checkbox"/>	Water/Sewer Enterprise Fund 031.522.20.6316
10.	EBO participation	ABE _____ % WAIVER yes ___ no ___ N/A _____ AABE _____ % WAIVER yes ___ no ___ N/A _____ WBE _____ % WAIVER yes ___ no ___ N/A _____ HBE _____ % WAIVER yes ___ no ___ N/A _____ NABE _____ % WAIVER yes ___ no ___ N/A _____



City of Jackson Department of Public Works

Council Agenda Item Brief

To: Mayor Tony T. Yarber

From: Jerriot Smash 
Director

Date: May 5, 2017

Agenda Item: Order authorizing the payment to Empire Truck Sales LLC, for the Vactor Combination Sewer Cleaner Truck

Item #:

Council Meeting: Regular Council Meeting, May 16, 2017

Consultant/Contractor: Empire Trucking Sales LLC

EBO: N/A

Purpose: Order Revising the FISCAL 2016-2017 Budget

Project/Contract Type: Payment

Funding Source: Enterprise Funds 031.522.206316

Schedule/Time:

DPW Manager: Bill Miley

Background: N/A

Estimated Fees: \$35,835.86

EBO Compliance Details: N/A

Talking Points:

- The repair of the equipment was necessary to maintain the City Sewer System and comply with the City's MDEQ Requirements

Office of the City Attorney

455 East Capitol Street
Post Office Box 2779
Jackson, Mississippi 39207-2779
Telephone: (601) 960-1799
Facsimile: (601) 960-1756

OFFICE OF THE CITY ATTORNEY

This **ORDER AUTHORIZING THE PAYMENT TO EMPIRE TRUCK SALES LLC, FOR THE REPAIR OF VACTOR COMBINATION SEWER CLEANER TRUCK** is legally sufficient for placement in NOVUS Agenda.



Monica D. Joiner, *City Attorney*
Nakesha Watkins, *Legal Counsel* 

6-16-17

DATE

OFFICE OF THE CITY ATTORNEY
JUL 11 2017
NW

OFFICE OF THE CITY ATTORNEY
JWE 26 2017

ORDER AUTHORIZING THE MAYOR TO EXECUTE ANY AND ALL DOCUMENTS FOR THE CORPS OF ENGINEERS SECTION 592 PROGRAM AGREEMENT

WHEREAS, the City of Jackson Mississippi has received notice about proposed Section 592 funding from the Corps of Engineers; and

WHEREAS, the Secretary of the Army is authorized to provide design and construction assistance, which may be in the form of grants or reimbursements of the Federal share of project costs, for water-related environmental infrastructure and resource protection and development projects in Mississippi (hereinafter the "Section 592 Program") pursuant to Section 592 of the Water Resources Development Act of 1999, Public Law 106-53, as amended (hereinafter "Section 592"); and

WHEREAS, Section 592 provides that the Secretary of the Army may provide assistance for a water-related environmental infrastructure and resource protection and development project only if the project is publicly owned; and

WHEREAS, the City of Jackson will use the proposed funds to improve its aging water and sewer infrastructure; and

WHEREAS, The Corps of Engineers will contribute (75%) of the cost share agreement, and the City of Jackson contribution will be (25%) of the total allocation amount from the Section 592 Program; and

IT IS FURTHER ORDERED that the Mayor is authorized to execute all related documents necessary to administer the Section 592 Program agreement including no-cost items and a copy of said agreement and all other related documents shall be filed for record with the City Clerk.

ITEM #

21

DATE:

BY:

SMASH, WILLIAMS, YARBER

CITY COUNCIL AGENDA ITEM 10 POINT DATA SHEET
June 16, 2017

P O I N T S		C O M M E N T S			
1.	Brief Description/Purpose	ORDER AUTHORIZING THE MAYOR TO EXECUTE ANY AND ALL DOCUMENTS FOR THE CORPS OF ENGINEERS SECTION 592 PROGRAM AGREEMENT			
2.	Public Policy Initiative 1. Youth & Education 2. Crime Prevention 3. Changes in City Government 4. Neighborhood Enhancement 5. Economic Development 6. Infrastructure and Transportation 7. Quality of Life	This item addresses Items 6, and 7			
3.	Who will be affected	Residents and businesses in all wards of the City of Jackson			
4.	Benefits	Water & Sewer Infrastructure Improvements			
5.	Schedule (beginning date)	This projects will begin as soon as contracts are signed.			
6.	Location: ▪ WARD ▪ CITYWIDE (yes or no) (area) ▪ Project limits if applicable	This project is located in all wards of the City of Jackson, MS			
7.	Action implemented by: ▪ City Department <input checked="" type="checkbox"/> ▪ Consultant <input type="checkbox"/>	This project will be implemented by the Engineering Division.			
8.	COST	Corps of Engineers (75%) City of Jackson, MS (25%)			
9.	Source of Funding ▪ General Fund <input type="checkbox"/> ▪ Grant <input type="checkbox"/> ▪ Bond <input checked="" type="checkbox"/> ▪ Other <input type="checkbox"/>	City's match will come from water and sewer revenue funds.			
10.	EBO participation	ABE _____%	WAIVER	yes ___ no ___	N/A _____
		AABE _____%	WAIVER	yes ___ no ___	N/A _____
		WBE _____%	WAIVER	yes ___ no ___	N/A _____
		HBE _____%	WAIVER	yes ___ no ___	N/A _____
		NABE _____%	WAIVER	yes ___ no ___	N/A _____



City of Jackson
Department of Public Works

Council Agenda Item Memorandum

To: Tony T. Yarber
From: Jerriot Smash, Interim Director *JS*
Date: June 16, 2017

Agenda Item: Corps of Engineers Section 592 Program Agreement
Item #:
Council Meeting: Regular Council Meeting, June 27, 2017
Consultant/Contractor: N/A

EBO Compliance Details:

- ABE: 0%
- AABE: %
- HBE: 0%
- NABE: 0%
- FBE: 0%

Purpose: Funding for Proposed Water & Sewer Infrastructure Projects
Cost: No Cost
Project/Contract Type: Program Agreement
Funding Source: Water and Sewer Revenue Funds
Schedule/Time: July 2017
DPW Manager: Charles Williams Jr., PE, PhD

Background:

Attached, you will find an item for the City Council Agenda to authorize the Mayor to execute all documents for the Corps of Engineers Section 592 Program agreement. The City solicited funds from the Corps of Engineers in 2014. The City of Jackson was alerted about proposed funds to be allocated in the next several months. The Department of Publics approves the authorization of any proposed documents to utilize the funds to improve its aging water and sewer infrastructure. If you have any questions, or require additional information, please do not hesitate to contact this office at (601) 960-2091.



**City of Jackson
Department of Public Works**

Talking Points:

Corps of Engineers Section 592 Program Agreement

- The City was alerted about proposed Corps of Engineers Section 592 funding.
- The City of Jackson solicited funds from the Corps of Engineers in 2014.
- This agenda will allow the Mayor to execute all related documents pertaining to the Section 592 program agreement.

Office of the City Attorney

455 East Capitol Street
Post Office Box 2779
Jackson, Mississippi 39207-2779
Telephone: (601) 960-1799
Facsimile: (601) 960-1756

OFFICE OF THE CITY ATTORNEY

This **ORDER AUTHORIZING THE MAYOR TO EXECUTE ANY AND ALL DOCUMENT FOR THE CORPS OF ENGINEERS SECTION 592 PROGRAM AGREEMENT** is legally sufficient for placement in NOVUS Agenda.



Monica D. Joiner, *City Attorney*

Nakesha Watkins, *Legal Counsel* 



DATE

OFFICE OF THE CITY ATTORNEY
JUN 20 2017
NW

OFFICE OF THE CITY ATTORNEY
JUNE 29, 2017
NDW

ORDER ACCEPTING AN ENGINEERING SERVICES AGREEMENT WITH CORNERSTONE ENGINEERING, LLC, FOR THE CABANISS CIRCLE STREET AND DRAINAGE IMPROVEMENT PROJECT, CITY PROJECT NUMBER 17B5003.401 (WARD 4)

WHEREAS, the Department of Public Works desires to have design engineering services for the Cabaniss Circle Street and Drainage Improvements, Jackson, Mississippi, Hinds County, Mississippi; and

WHEREAS, Cornerstone Engineering, LLC, a multi-disciplinary civil engineering firm located in Jackson, Mississippi submitted their firms Statement of Qualifications to provide professional engineering services for the Engineering Division within the Department of Public Works; and

WHEREAS, Cornerstone Engineering, LLC, has submitted a proposal based on its Statement of Qualifications to provide the City of Jackson design engineering services at a cost not to exceed \$28,000.00; and

WHEREAS, the Department of Public Works recommends the City of Jackson enter into an Engineering Services Agreement with Cornerstone Engineering, LLC, in an amount not to exceed \$28,000.00.

IT IS, THEREFORE, ORDERED that an engineering services agreement with Cornerstone Engineering, LLC, Inc., in an amount not to exceed \$28,000.00, for the Cabaniss Circle Street and Drainage Improvement Project, City Project Number 17B5003.401 is accepted.

ITEM # 22 _____
DATE: _____
BY: **SMASH, WILLIAMS, YARBER**



**City of Jackson
Department of Public Works**

Council Agenda Item Memorandum

To: Tony T. Yarber, Mayor

From: Jerriot Smash, Interim Director 
Public Works Department

Date: June 19, 2017

Agenda Item: Cabaniss Circle Street and Drainage Improvements

Item #:

Council Meeting: Regular Council Meeting, June 27, 2017

Consultant/Contractor: Cornerstone Engineering, LLC

EBO Compliance Details:

- ABE: 0%
- AABE: 100%
- HBE: 0%
- NABE: N/A
- FBE: 0%

Purpose: Water & Drainage Infrastructure Improvements

Cost: Cost \$28,000.00

Project/Contract Type: Design Engineering Services

Funding Source: Fund 156

Schedule/Time: June 2017

DPW Manager: Charles Williams Jr., PE, PhD

Background:

Attached you will find an item for the City Council Agenda requesting authority to enter into a professional engineering service agreement with Cornerstone Engineering, LLC, for the Cabaniss Circle Street Drainage Improvements. Cabaniss Circle is in need of major road, drainage and water line infrastructure improvements. The City of Jackson Department of Public works engaged discussion with Cornerstone Engineering about preparing a proposal for profession engineering design to repair the required infrastructure improvements on Cabaniss Circle.



**City of Jackson
Department of Public Works**

City staff has reviewed the scope of services, and recommends Cornerstone Engineering, LLC, based on their firm's qualifications to perform design engineering services.

It is the recommendation of this office that this design engineering services contract be awarded. If you have any questions, or require additional information, please do not hesitate to contact this office at (601) 960-2091.

Talking Points:

Cabaniss Circle Street and Drainage Improvements

- The City of Jackson has received several complaints about the road, drainage, and water line infrastructure on Cabaniss Circle in need of improvements.
- The City talked with Cornerstone Engineering, LLC about providing a proposal to design infrastructure improvements on Cabaniss Circle.
- Cornerstone Engineering provided a proposal for the infrastructure improvements, and the City agrees with proposal for the needed improvements.
- The Consultant will provide plans and specification for all the proposed work.

CITY COUNCIL AGENDA ITEM 10 POINT DATA SHEET
June 19, 2017

P O I N T S	C O M M E N T S																																													
1. Brief Description/Purpose	ORDER ACCEPTING AN ENGINEERING SERVICES AGREEMENT WITH CORNERSTONE ENGINEERING, LLC, FOR THE CABANISS CIRCLE STREET AND DRAINAGE IMPROVEMENT PROJECT, CITY PROJECT NUMBER 17B5003.401 (WARD 4)																																													
2. Public Policy Initiative 1. Youth & Education 2. Crime Prevention 3. Changes in City Government 4. Neighborhood Enhancement 5. Economic Development 6. Infrastructure and Transportation 7. Quality of Life	This item addresses Items 5, 6 and 7.																																													
3. Who will be affected	Residents on Cabaniss Circle																																													
4. Benefits	Water and Drainage Infrastructure Improvements																																													
5. Schedule (beginning date)	When contracts are executed.																																													
6. Location: ▪ WARD ▪ CITYWIDE (yes or no) (area) ▪ Project limits if applicable	This project is located in Ward 4.																																													
7. Action implemented by: ▪ City Department <input checked="" type="checkbox"/> ▪ Consultant <input type="checkbox"/>	This project was implemented by the Engineering Division.																																													
8. COST	Engineering Design Cost- \$28,000.00																																													
9. Source of Funding ▪ General Fund <input type="checkbox"/> ▪ Grant <input type="checkbox"/> ▪ Bond <input type="checkbox"/> ▪ Other <input checked="" type="checkbox"/>	Fund 156 Account No. 156-45190-7B5003-401-6413																																													
10. EBO participation	<table style="width: 100%; border: none;"> <tr> <td>ABE</td> <td>_____ %</td> <td>WAIVER</td> <td>yes</td> <td>___</td> <td>no</td> <td>___</td> <td>N/A</td> <td>___</td> </tr> <tr> <td>AABE</td> <td>_____ %</td> <td>WAIVER</td> <td>yes</td> <td>___</td> <td>no</td> <td>___</td> <td>N/A</td> <td>___</td> </tr> <tr> <td>WBE</td> <td>_____ %</td> <td>WAIVER</td> <td>yes</td> <td>___</td> <td>no</td> <td>___</td> <td>N/A</td> <td>___</td> </tr> <tr> <td>HBE</td> <td>_____ %</td> <td>WAIVER</td> <td>yes</td> <td>___</td> <td>no</td> <td>___</td> <td>N/A</td> <td>___</td> </tr> <tr> <td>NABE</td> <td>_____ %</td> <td>WAIVER</td> <td>yes</td> <td>___</td> <td>no</td> <td>___</td> <td>N/A</td> <td>___</td> </tr> </table>	ABE	_____ %	WAIVER	yes	___	no	___	N/A	___	AABE	_____ %	WAIVER	yes	___	no	___	N/A	___	WBE	_____ %	WAIVER	yes	___	no	___	N/A	___	HBE	_____ %	WAIVER	yes	___	no	___	N/A	___	NABE	_____ %	WAIVER	yes	___	no	___	N/A	___
ABE	_____ %	WAIVER	yes	___	no	___	N/A	___																																						
AABE	_____ %	WAIVER	yes	___	no	___	N/A	___																																						
WBE	_____ %	WAIVER	yes	___	no	___	N/A	___																																						
HBE	_____ %	WAIVER	yes	___	no	___	N/A	___																																						
NABE	_____ %	WAIVER	yes	___	no	___	N/A	___																																						

Office of the City Attorney

455 East Capitol Street
Post Office Box 2779
Jackson, Mississippi 39207-2779
Telephone: (601) 960-1799
Facsimile: (601) 960-1756

OFFICE OF THE CITY ATTORNEY

This **ORDER ACCEPTING AN ENGINEERING SERVICES AGREEMENT WITH CORNERSTONE ENGINEERING, LLC, FOR THE CABANISS CIRCLE STREET AND DRAINAGE IMPROVEMENT PROJECT, CITY PROJECT NUMBER 17B5003.401 (WARD 4)** is legally sufficient for placement in NOVUS Agenda.



Monica D. Joiner, *City Attorney*

Nakesha Watkins, *Legal Counsel* nw

6/20/17
DATE

OFFICE OF THE CITY ATTORNEY
JUN 20 2017
NOVUS 17B5003.401

ORDER REVISING THE FISCAL YEAR 2016-2017 BUDGET OF THE DEPARTMENT OF PUBLIC WORKS (ALL WARDS)

OFFICE OF THE CITY ATTORNEY
JUNE 20, 2017
RW

WHEREAS, certain unanticipated needs and allocations in the amount of \$292,100 have arisen since the adoption of Fiscal Year 2016-2017 budget; and

WHEREAS, the Fiscal Year 2016-2017 budget needs to be revised to allow the Engineering Division to make the final payment to Entergy for the Fortification Street Project; and

WHEREAS, the following funds are being revised:

001-448206111	\$ 9,100
001-448506111	\$ 25,000
001.451106111	\$ 63,000
001-451246113	\$ 95,000
001-451256113	\$100,000

IT IS, THEREFORE, ORDERED that the Fiscal Year 2015-2016 budget be revised in the amount of \$292,100 as follows:

<u>To/From</u>	<u>Fund/Account Number</u>	<u>Amount</u>
From	001-448206111	(\$ 9,100)
	001-448506111	(\$ 25,000)
	001-451106111	(\$ 63,000)
	001-451246113	(\$ 95,000)
	001-451256113	(\$ 100,000)
To	001-450106451	\$292,100

ITEM # 23
DATE: _____
BY: SMASH, THOMAS, YARBER

CITY COUNCIL AGENDA ITEM 10 POINT DATA SHEET

June 19, 2017
DATE

P O I N T S		C O M M E N T S								
1.	Brief Description/Purpose	ORDER AMENDING PUBLIC WORKS DEPARTMENT FISCAL YEAR 2016-2017 BUDGET								
2.	Public Policy Initiative 1. Youth & Education 2. Crime Prevention 3. Changes in City Government 4. Neighborhood Enhancement 5. Economic Development 6. Infrastructure and Transportation 7. Quality of Life	Infrastructure and Transportation								
3.	Who will be affected	Citizens of the Jackson								
4.	Benefits									
5.	Schedule (beginning date)	Beginning upon approval								
6.	Location: ▪ WARD ▪ CITYWIDE (yes or no) (area) ▪ Project limits if applicable	Citywide								
7.	Action implemented by: ▪ City Department <input type="checkbox"/> ▪ Consultant <input type="checkbox"/>	Public Works Administration								
8.	COST	N/A								
9.	Source of Funding ▪ General Fund <input type="checkbox"/> ▪ Grant <input type="checkbox"/> ▪ Bond <input type="checkbox"/> ▪ Other <input type="checkbox"/>	From	001-448206111				(\$ 9,100)			
			001-448506111				(\$ 25,000)			
			001-451106111				(\$ 63,000)			
			001-451246113				(\$ 95,000)			
			001-451256113				(\$ 100,000)			
		To	001-450106451				\$292,100			
10.	EBO participation	ABE	_____ %	WAIVER	yes	___	no	___	N/A	_____
		AABE	_____ %	WAIVER	yes	___	no	___	N/A	_____
		WBE	_____ %	WAIVER	yes	___	no	___	N/A	_____
		HBE	_____ %	WAIVER	yes	___	no	___	N/A	_____
		NABE	_____ %	WAIVER	yes	___	no	___	N/A	_____

TO: Tony Yarber, Mayor

FROM: Jerriot Smash, 
Interim Public Works Director

DATE: June 19, 2017

RE: AGENDA ITEM FOR THE CITY COUNCIL MEETING

Attached, you will find an item for the City Council Agenda requesting a budget revision to allow for the reallocation of funds. The requested change in accounts comes from personnel services due to vacated positions. The reallocation of these funds does not take away from, or compromise, nor affect the budget positions.

This requested reallocation of funds will allow the Engineering Division to make the final payment to Entergy in the amount of \$292,100 for the Fortification Street Project.

It is the recommendation of this office that this reallocation be approved. If you have any questions, or require additional information, please do not hesitate to contact this office at (601) 960-2204.

/et

Office of the City Attorney

455 East Capitol Street
Post Office Box 2779
Jackson, Mississippi 39207-2779
Telephone: (601) 960-1799
Facsimile: (601) 960-1756

OFFICE OF THE CITY ATTORNEY

This **ORDER REVISING THE FISCAL YEAR 2015 - 2016 BUDGET (MEMO DATE: JUNE 19, 2017)** is legally sufficient for placement in NOVUS Agenda.



Monica D. Joiner, *City Attorney*
Nakesha Watkins, *Legal Counsel* 



DATE

OFFICE OF THE CITY ATTORNEY
June 28, 2017
mm

ORDER REVISING THE FISCAL YEAR 2016-2017 OF THE DEPARTMENT OF PUBLIC WORKS (ALL WARDS)

WHEREAS, certain unanticipated needs and allocations in the amount of \$80,900 have arisen since the adoption of Fiscal Year 2016-2017 budget; and

WHEREAS, the Fiscal Year 2016-2017 budget needs to be revised to allow the Vehicle Management Division to pay operational costs through the 2016-2017 Fiscal Year to NAPA Auto Parts; and

WHEREAS, the following funds are being revised:

001-448206111 \$ 15,900
001-451246111 \$ 65,000

IT IS, THEREFORE, ORDERED that the Fiscal Year 2015-2016 budget be revised in the amount of \$80,900 as follows:

<u>To/From</u>	<u>Fund/Account Number</u>	<u>Amount</u>
From	001-448206111	(\$ 15,900)
	001-451106111	(\$ 65,000)
To	001-456106419	\$80,900

ITEM # 24
DATE: _____
BY: SMASH, THOMAS, YARBER

CITY COUNCIL AGENDA ITEM 10 POINT DATA SHEET

June 19, 2017
DATE

P O I N T S		C O M M E N T S			
1.	Brief Description/Purpose	ORDER AMENDING PUBLIC WORKS DEPARTMENT FISCAL YEAR 2016-2017 BUDGET			
2.	Public Policy Initiative 1. Youth & Education 2. Crime Prevention 3. Changes in City Government 4. Neighborhood Enhancement 5. Economic Development 6. Infrastructure and Transportation 7. Quality of Life	Infrastructure and Transportation			
3.	Who will be affected	Citizens of the Jackson			
4.	Benefits				
5.	Schedule (beginning date)	Beginning upon approval			
6.	Location: ▪ WARD ▪ CITYWIDE (yes or no) (area) ▪ Project limits if applicable	Citywide			
7.	Action implemented by: ▪ City Department <input type="checkbox"/> ▪ Consultant <input type="checkbox"/>	Public Works Administration			
8.	COST	N/A			
9.	Source of Funding ▪ General Fund <input type="checkbox"/> ▪ Grant <input type="checkbox"/> ▪ Bond <input type="checkbox"/> ▪ Other <input type="checkbox"/>	From	001-448206111 001-451246111	(\$ 15,900) (\$ 65,000)	
		To	001-450106451	\$ 80,900	
10.	EBO participation	ABE _____%	WAIVER	yes ___ no ___	N/A _____
		AABE _____%	WAIVER	yes ___ no ___	N/A _____
		WBE _____%	WAIVER	yes ___ no ___	N/A _____
		HBE _____%	WAIVER	yes ___ no ___	N/A _____
		NABE _____%	WAIVER	yes ___ no ___	N/A _____

TO: Tony Yarber, Mayor

FROM: Jerriot Smash, 
Interim Public Works Director

DATE: May 17, 2017

RE: AGENDA ITEM FOR THE CITY COUNCIL MEETING

Attached, you will find an item for the City Council Agenda requesting a budget revision to allow for the reallocation of funds. The requested change in accounts comes from personnel services due to vacated positions. The reallocation of these funds does not take away from, or compromise, and nor affect the budget positions.

This requested reallocation of funds will allow the Vehicle Management Division to pay NAPA's past due and current operational cost for the remainder of 2017 fiscal year.

It is the recommendation of this office that this reallocation be approved. If you have any questions, or require additional information, please do not hesitate to contact this office at (601) 960-2204.

/et

Office of the City Attorney

455 East Capitol Street
Post Office Box 2779
Jackson, Mississippi 39207-2779
Telephone: (601) 960-1799
Facsimile: (601) 960-1756

OFFICE OF THE CITY ATTORNEY

This **ORDER REVISING THE FISCAL YEAR 2015 - 2016 BUDGET (MEMO DATE: MAY 17, 2017)** is legally sufficient for placement in NOVUS Agenda.



Monica D. Joiner, *City Attorney*

Nakesha Watkins, *Legal Counsel* 



DATE

OFFICE OF THE CITY ATTORNEY
JUNE 20 2017
NWK

OFFICE OF THE CITY ATTORNEY
JUL 20, 2017
nmw

**ORDER AUTHORIZING THE MAYOR TO EXECUTE
MEMORANDUM OF UNDERSTANDING WITH THE GREATER
EASTOVER FOUNDATION (WARD 1)**

WHEREAS, the Greater Eastover Foundation has notified the City of Jackson about plans to enhance the aesthetics of two bridge structures owned and maintained by the City of Jackson located in the Eastover Neighborhood; and

WHEREAS, the Greater Eastover Foundation wishes to enter into a memorandum of understanding outlining the obligations between the City of Jackson and the Greater Eastover Foundation pertaining to the proposed aesthetic improvements to the Lake Circle Bridge and Eastover Bridge Structure.

WHEREAS, the Greater Eastover Foundation plans to remove the existing guardrails from the Lake Circle Bridge and replace with an iron railing inclusive of brick columns on West and East approach way; and

WHEREAS, the Greater Eastover Foundation plans to place a brick facade around the existing concrete barrier railing on the Eastover Bridge Structure; and

WHEREAS, the Greater Eastover Foundation will ensure per the agreed MOU that the proposed aesthetic improvements will meet or exceed the current local, state, and Federal bridge requirement standards set forth by each governing agency.

IT IS, THEREFORE, ORDERED that the Mayor is authorized to execute a memorandum of understanding with the Greater Eastover Foundation to perform aesthetic improvements to the Lake Circle Bridge and Eastover Bridge structures located in the Eastover Subdivision.

ITEM #

25

DATE:

BY:

SMASH, WILLIAMS, YARBER



**City of Jackson
Department of Public Works**

Council Agenda Item Memorandum

To: Tony T. Yarber
From: Jerriot Smash, Interim Director *JR*
Date: June 5, 2017

Agenda Item: COJ & Greater Eastover Foundation
Item #:
Council Meeting: Regular Council Meeting, June 13, 2017
Consultant/Contractor: N/A
EBO Compliance Details:

Purpose: Memorandum of Understanding
Cost: No Cost
Project/Contract Type: Lake Circle Bridge & Eastover Bridge
Funding Source: N/A
Schedule/Time: N/A
DPW Manager: Charles Williams Jr., PE, PhD

Background:

Attached, you will find an item for the City Council Agenda requesting the City of Jackson enter into a Memorandum of Understanding with the Greater Eastover Foundation. The Foundation has approached the City of Jackson, Department of Public Works regarding the aesthetic improvements to Lake Circle Bridge and Eastover Bridge. The memorandum of understanding will outline the responsibilities regarding each entities responsibility regarding the maintenance and upkeep of the bridge structures.

The Department of Public Works recommends the City of Jackson enter into a Memorandum of Understanding regarding the aesthetic improvements to the Lake Circle Bridge and Eastover Bridge Structures.

If you have any questions, or require additional information, please do not hesitate to contact this office at (601) 960-2091.



**City of Jackson
Department of Public Works**

Talking Points:

COJ & Greater Eastover Foundation MOU

- The Greater Eastover Foundation approached the City of Jackson, Department of Public Works about making aesthetic improvements to the Lake Circle and Eastover Bridge structures.
- The Department of Public Works and the Legal Department have reviewed the MOU provided by the Greater Eastover Foundation.
- The Legal Department will provides those comments to the legal representative for the Greater Eastover Foundation.
- The Department of Public Works has no objections to entering a MOU with the Greater Eastover Foundation for aesthetic improvements to the Lake Circle and Eastover Bridge structures.

CITY COUNCIL AGENDA ITEM 10 POINT DATA SHEET
June 2, 2017

P O I N T S		C O M M E N T S			
1.	Brief Description/Purpose	ORDER AUTHORIZING THE MAYOR TO EXECUTE A MEMORANDUM OF UNDERSTANDING WITH THE GREATER EASTOVER FOUNDATION (WARD 1)			
2.	Public Policy Initiative 1. Youth & Education 2. Crime Prevention 3. Changes in City Government 4. Neighborhood Enhancement 5. Economic Development 6. Infrastructure and Transportation 7. Quality of Life	4			
3.	Who will be affected	Residents who live in the Eastover Subdivision			
4.	Benefits	Neighborhood Enhancement			
5.	Schedule (beginning date)	Execution of the MOU			
6.	Location: ▪ WARD ▪ CITYWIDE (yes or no) (area) ▪ Project limits if applicable	This project is located in Ward 1			
7.	Action implemented by: ▪ City Department <input type="checkbox"/> ▪ Consultant <input type="checkbox"/>	This project was implemented by the Engineering Division.			
8.	COST	No Cost			
9.	Source of Funding ▪ General Fund <input type="checkbox"/> ▪ Grant <input type="checkbox"/> ▪ Bond <input type="checkbox"/> ▪ Other <input checked="" type="checkbox"/>				
10.	EBO participation	ABE _____%	WAIVER	yes ___ no ___	N/A ___
		AABE _____%	WAIVER	yes ___ no ___	N/A ___
		WBE _____%	WAIVER	yes ___ no ___	N/A ___
		HBE _____%	WAIVER	yes ___ no ___	N/A ___
		NABE _____%	WAIVER	yes ___ no ___	N/A ___

Office of the City Attorney

455 East Capitol Street
Post Office Box 2779
Jackson, Mississippi 39207-2779
Telephone: (601) 960-1799
Facsimile: (601) 960-1756

OFFICE OF THE CITY ATTORNEY

OFFICE OF THE CITY ATTORNEY
JUN 20 2017
NW

This **ORDER AUTHORIZING THE MAYOR TO EXECUTE A MEMORANDUM OF UNDERSTANDING WITH THE GREATER EASTOVER FOUNDATION (WARD 1)** is legally sufficient for placement in NOVUS Agenda.



Monica D. Joiner, *City Attorney*
Nakesha Watkins, *Legal Counsel* NW



DATE

ORDER AUTHORIZING THE DONATION OF A MATCHING CONTRIBUTION OF \$6,000 TO GENERAL MISSIONARY BAPTIST STATE CONVENTION YOUNG PEOPLES DEPARTMENT IN SUPPORT OF THE DEVELOPMENT, PROMOTION AND COORDINATION OF THE ARTS WITHIN THE CITY AND AUTHORIZING THE MAYOR TO EXECUTE A CONTRACT WITH THE ORGANIZATION.

WHEREAS, Section 39-15-1 of the Mississippi Code of 1972, as amended, authorizes and empowers the governing authorities of any municipality, in their discretion, to expend monies from the general fund to match any other funds available for the purpose of supporting the development, promotion, and coordination of the arts within such municipality; and

WHEREAS, the General Missionary Baptist State Convention Young Peoples Department has requested that the City of Jackson, Mississippi support its efforts to promote and coordinate the arts by donating \$6,000; and

WHEREAS, the General Missionary Baptist State Convention Young Peoples Department will conduct workshops and rehearsals for youth attending the State Convention that will result in a major performance of youth and a nationally known artist; and

WHEREAS, the governing authorities find that the \$6,000 donation to the General Missionary Baptist State Convention Young Peoples Department will benefit the community through the leadership training opportunities and workshops and will support the development, promotion, and coordination of the arts within the City of Jackson; and

WHEREAS, it is in the best interest of the City of Jackson to support the agency's efforts and award the funds sought.

IT IS THEREFORE ORDERED that a donation of six thousand dollars (\$6,000.00) to the General Missionary Baptist State Convention, Incorporated, is authorized to be taken from Account Number 1R-3550, the Municipal General Fund Unrestricted Fund Balance, for the purpose of providing the Young Peoples Department with workshops, rehearsals, activities, and other opportunities for the youth that allow them to showcase their gifts and talents through song, mime, public speaking, debate, drama, drill team and step ministries.

IT IS FURTHER ORDERED that the Mayor is authorized to execute a contract agreement with the General Missionary Baptist State Convention, Incorporated, to memorialize said donation.

IT IS FINALLY ORDERED that said expenditures be made on a reimbursement and matching fund basis.

AGENDA ITEM: 26
DATE: June 27, 2017
BY: Kenneth I. Stokes

RESOLUTION OF THE CITY COUNCIL OF JACKSON, MISSISSIPPI IN SUPPORT OF
RECOGNIZING COUNCILWOMAN MARGARET BARRETT SIMON FOR UNSELFISH
DEDICATION AND DILIGENCE IN SERVICE TO OUR CITY, STATE AND NATION.

WHEREAS, the state of Mississippi and the nation join the City of Jackson, Mississippi in recognizing the tireless work and service of Councilwoman Margaret Barrett Simon; and

WHEREAS, she is a tribute to St. Joseph High School and the University of Southern Mississippi; and

WHEREAS, her first election came in 1985 with the commencement of the Mayor-Council form of government in Jackson; the longest serving councilperson under this government form, Councilwoman Barrett Simon has served as President, Vice President, Chair of the Planning, Budget, Rules, Transportation and Legislative Committees, along with the Homeless Task Force; and

WHEREAS, keenly aware of civic responsibilities, Councilwoman Barrett Simon has given freely of “ *time, talent and gift*” to the Salvation Army, Farish Street YMCA, Jackson State University School of Liberal Arts, and the Mississippi Sports Hall of Fame; and

WHEREAS, on a broader scope, her work as Advisory Council Member and Chair of the National League of Cities does not go unnoticed; further, her contributions include: National President of Women in Municipal Government, State President of Women in Municipal Government, the Urban Poverty Task Force, National League of Cities Institute for Youth, Education, and Families, and the Mississippi Municipal Association.

THEREFORE, BE IT RESOLVED, that the City Council of Jackson, Mississippi salutes her husband, Dr. Al Simon, and their five daughters for the years of support you have shared to complement Councilwoman Margaret Barrett Simon during her many years of unselfish dedication and diligent service to the City of Jackson, the State of Mississippi and the nation. “*Bon Voyage*, Councilwoman Margaret Barrett Simon.

SO RESOLVED, this the _____ day of June, 2017.

Agenda Item No. 27
Agenda Date: June 27, 2017
By: K. Stokes

RESOLUTION OF THE CITY COUNCIL OF JACKSON, MISSISSIPPI IN SUPPORT OF
RECOGNIZING COUNCIL PRESIDENT TYRONE HENDRIX FOR VIBRANT
LEADERSHIP AND SERVICE.

WHEREAS, the state of Mississippi and the nation join the City of Jackson, Mississippi in recognizing the unique work and service of Council President Tyrone Hendrix; and

WHEREAS, his genuine love and concern for people led Councilman Hendrix to seek the position as representative for Ward 6; the youngest councilperson, he has adopted the life commitment of improving the welfare and lives of citizens in our community; and

WHEREAS, Councilman Hendrix graduated from Forest Hill High School and received both the Bachelor of Science and Master of Arts degrees from Jackson State University; and

WHEREAS, at the age of thirteen, the death of his mother, Mrs. Pondra Hendrix, greatly impacted his life and left his father, Mr. Henry Hendrix, to continue with his development; and

WHEREAS, Councilman Hendrix's career began as a community organizer in low- moderate income neighborhoods through the implementation of programs to institute community policing, secure additional street lights, living wage ordinances and acquisition of residential speed bumps; and

WHEREAS, his life's work has blossomed: organizer for "*Obama for America*" in the 2nd and 3rd Congressional Districts during President Obama's 2008 campaign; garnered grassroots political support for the passage of the Affordable Care Act; Deputy Campaign Manager for Johnny Dupree Campaign for Governor; founder, along with his wife, Ercilla, of a grassroots political firm; and

WHEREAS, during his Council tenure, Councilman Hendrix has served as Chair of the Legislative and Rules Committees; Vice Chair for the Planning, Economic Development and Government Operations Committees; further, he sits on the Budget and Education/Youth Ad Hoc Committees; elected City Council President; his themes center on accountability, governmental and financial transparency.

THEREFORE, BE IT RESOLVED, that the City Council of Jackson, Mississippi salutes his wife, Mrs. Ercilla Dometz-Hendrix, and children- - Farah and Tyrone, II, for the years of support you shared to complement Council President Tyrone Hendrix during his vibrant leadership and service to the City of Jackson, the State of Mississippi and the nation. We wish for Council President Tyrone Hendrix, a "**good life.**"

SO RESOLVED, this the ____ day of June, 2017.

Agenda Item No. 28

Agenda Date: June 27, 2017

By: K. STOKES

RESOLUTION OF THE CITY COUNCIL OF JACKSON, MISSISSIPPI, ENCOURAGING THE CORPORATE OFFICES OF SAVE-A-LOT GROCERY STORE TO RECONSIDER PERMANENTLY CLOSING ITS NAKOMA DRIVE LOCATION.

WHEREAS, the City of Jackson recognizes the importance of making sure all communities in the City have access to healthy food; and

WHEREAS, the City of Jackson critically values keeping stores and businesses in neighborhoods; and

WHEREAS, it has come to the attention of the City that Save-A-Lot plans to close it's store located on Nakoma Drive on July 8, 2017 due to issues with the condition of the building; and

WHEREAS, the City wishes to inform Save-a-Lot of the City's desire for the store to remain in the area as closing it would have a deleterious effect on the community; and

NOW, THEREFORE BE IT RESOLVED that the City of Jackson formally encourages the Corporate Offices of Save-A-Lot to keep the Nakoma Drive store open.

BE IT FURTHER RESOLVED that the City of Jackson officially requests that the Corporate Offices of Save-A-Lot present to the City any partnership possibilities or options for the City to work with Save-A-Lot to keep this facility open.

SO RESOLVED, THIS THE 27th DAY OF JUNE, 2017.

**Agenda Item: 29
Date: June 27, 2017
By: Priester**

**ORDER OF THE CITY COUNCIL OF JACKSON, MISSISSIPPI
REVISING FISCAL YEAR 2016-2017 BUDGET TO FUND A PART-TIME
POSITION IN THE OFFICE OF THE CITY CLERK.**

WHEREAS, the needs and demands of the Office of the City Clerk require that one previously frozen position be filled; and

WHEREAS, the City Council of Jackson, Mississippi deems that the funding of said position is necessary to meet the staffing needs within the Office of the City Clerk and is in the best interests of its citizenry.

IT IS THEREFORE ORDERED, by the City Council of Jackson, Mississippi that \$10,234.28 is taken from Account Number 1R-3550, the Municipal General Fund Unrestricted Fund Balance and that \$10,088 is placed in Account Number 402006112 for part-time salaries in the Office of the City Clerk and that \$146.28 is placed in Account Number 402006136 for Medicare taxes associated with funding this part time position in the Office of the City Clerk.

Agenda No.:

Date: 06/27/2017

By: De'Keither Stamps

ORDER REVISING THE FISCAL YEAR 2016-2017 BUDGET OF THE DEPARTMENT OF PARKS AND RECREATION (WARDS 3 & 4) (JONES & YARBER)

OFFICE OF THE CITY ATTORNEY
[Signature]

WHEREAS, certain unanticipated needs and allocations in the amount of \$2,000.00 have arisen within the adoption of the Fiscal Year 2016-2017 budget; and

WHEREAS, the Fiscal Year 2016-2017 budget must be revised to provide funding to allow the golf courses to purchase lawn and garden equipment; and

WHEREAS, the following funds are revised:

To/From	Fund/Account Number	Amount
From:	005-504.30-6299	(\$2,000.00)
To:	005-504.10-6846	\$2,000.00

IT IS, THEREFORE, ORDERED that the Fiscal Year 2016-2017 budget be revised in the amount of \$2,000.00 as follows:

To/From	Fund/Account Number	Amount
From:	005-504.30-6299	(\$2,000.00)
To:	005-504.10-6846	\$2,000.00

ITEM #:
 DATE:

31

BY: JONES, YARBER



**The City of Jackson
Department of Parks
and Recreation**

Memo

To: Mayor Tony Yarber
From: Allen Jones, Director
Date: June 20, 2017
Re: Order Revising FY 2016-17 Budget of the Department of Parks and Recreation
(Wards 3 & 4)

Parks and Recreation will move funds to purchase lawn and garden equipment for the golf courses, because at this time, the Golf Course Division does not have a lawn and garden equipment account.

The Parks and Recreation Department recommends that this agenda item be approved. If you have any questions or comments, please feel free to contact us at (601) 960-0716.

AJ/pb

CITY COUNCIL AGENDA ITEM 10 POINT DATA SHEET

06-20-17
DATE

OFFICE OF THE CITY ATTORNEY

P O I N T S		C O M M E N T S																																																							
1.	Brief Description	Order revising the fiscal year 2016-2017 budget of the Department of Parks and Recreation (Wards 3 & 4)																																																							
2.	Public Policy Initiative 1. Youth & Education 2. Crime Prevention 3. Changes in City Government 4. Neighborhood Enhancement 5. Economic Development 6. Infrastructure and Transportation 7. Quality of Life	4. Neighborhood Enhancement 6. Infrastructure and Transportation 7. Quality of Life																																																							
3.	Who will be affected	City of Jackson and surrounding residents.																																																							
4.	Benefits	Purchase equipment to properly maintain the golf courses.																																																							
5.	Schedule (beginning date)	Upon City Council Approval																																																							
6.	Location: ■ WARD ■ CITYWIDE (yes or no) (area) ■ Project limits if applicable	Wards 3 & 4																																																							
7.	Action implemented by: ■ City Department <input type="checkbox"/> ■ Consultant <input type="checkbox"/>	Department of Parks and Recreation																																																							
8.	COST	\$2,000.00																																																							
9.	Source of Funding ■ General Fund <input checked="" type="checkbox"/> ■ Grant <input type="checkbox"/> ■ Bond <input type="checkbox"/> ■ Other <input type="checkbox"/>	Parks and Recreation Fund: 005-504.30-6299																																																							
10.	EBO participation	<table border="0"> <tr> <td>ABE</td><td>_____</td><td>%</td><td>WAIVER</td><td>___</td><td>Yes</td><td>___</td><td>No</td><td>___</td><td>N/A</td><td><u>X</u></td> </tr> <tr> <td>AABE</td><td>_____</td><td>%</td><td>WAIVER</td><td>___</td><td>Yes</td><td>___</td><td>No</td><td>___</td><td>N/A</td><td><u>X</u></td> </tr> <tr> <td>WBE</td><td>_____</td><td>%</td><td>WAIVER</td><td>___</td><td>Yes</td><td>___</td><td>No</td><td>___</td><td>N/A</td><td><u>X</u></td> </tr> <tr> <td>HBE</td><td>_____</td><td>%</td><td>WAIVER</td><td>___</td><td>Yes</td><td>___</td><td>No</td><td>___</td><td>N/A</td><td><u>X</u></td> </tr> <tr> <td>NABE</td><td>_____</td><td>%</td><td>WAIVER</td><td>___</td><td>Yes</td><td>___</td><td>No</td><td>___</td><td>N/A</td><td><u>X</u></td> </tr> </table>	ABE	_____	%	WAIVER	___	Yes	___	No	___	N/A	<u>X</u>	AABE	_____	%	WAIVER	___	Yes	___	No	___	N/A	<u>X</u>	WBE	_____	%	WAIVER	___	Yes	___	No	___	N/A	<u>X</u>	HBE	_____	%	WAIVER	___	Yes	___	No	___	N/A	<u>X</u>	NABE	_____	%	WAIVER	___	Yes	___	No	___	N/A	<u>X</u>
ABE	_____	%	WAIVER	___	Yes	___	No	___	N/A	<u>X</u>																																															
AABE	_____	%	WAIVER	___	Yes	___	No	___	N/A	<u>X</u>																																															
WBE	_____	%	WAIVER	___	Yes	___	No	___	N/A	<u>X</u>																																															
HBE	_____	%	WAIVER	___	Yes	___	No	___	N/A	<u>X</u>																																															
NABE	_____	%	WAIVER	___	Yes	___	No	___	N/A	<u>X</u>																																															

CHANGE REQUESTED IN BUDGET

CRIB FORM
2017

CHANGES ALLOWED WITHOUT COUNCIL APPROVAL:

- A CHANGE BETWEEN DIVISIONS IN A DEPARTMENT WITHIN SAME CATEGORY
- A CHANGE BETWEEN LINE ITEMS WITHIN A DIVISION OR DEPARTMENT WITHIN SAME

FROM				TO				
ACCOUNT NO.	Current Budget	This Change	Revised Budget	ACCOUNT NO.	Current Budget	This Change	Revised Budget	
1	005-504.10-6419	35,489	200	35,289	005-504.52-6419	50	200	250
2	005-504.30-6299	6,200	2,000	4,200	005-504.10-6876	0	2,000	2,000
3	005-504.30-6316	8,729	2,500	6,229	005-504.10-6316	48,000	2,500	50,500
4	005-504.10-6516	21,000	1,000	20,000	005-504.30-6516	4,300	1,000	5,300
5								
6								
7								
8								
9								
10								
TOTAL				TOTAL				

THESE CHANGES WILL BE MADE UPON REQUEST

CHANGES THAT MUST HAVE COUNCIL APPROVAL:

- A CHANGE BETWEEN CATEGORIES (Personnel, Supplies, Other Services & Charges, Capital)
- AN ADDITION TO THE BUDGET

FROM (DECREASE)				TO (INCREASE)			
ACCOUNT NO.	Current Budget	This Change	Revised Budget	ACCOUNT NO.	Current Budget	This Change	Revised Budget
1							
2							
3							
4							
5							
6							
7							
8							
9							
10							
TOTAL				TOTAL			

THESE CHANGES MUST WAIT FOR QUARTERLY REVISION

FOR THE DEPARTMENT OF Parks & Recreation

REQUEST APPROVED:	ENTERED BY:
DEPARTMENT DIRECTOR SIGNATURE	Patrice Bernard
DATE	DATE
6/20/17	6/20/17
CAO'S OFFICE	BUDGET SECTION
DATE	DATE

JUSTIFICATION: Transfer of funds needed to allow Park Maintenance Division to pay bills, purchase supplies, and make repairs.

Office of the City Attorney

455 East Capitol Street
Post Office Box 2779
Jackson, Mississippi 39207-2779
Telephone: (601) 960-1799
Facsimile: (601) 960-1756

OFFICE OF THE CITY ATTORNEY

This ORDER REVISING THE FISCAL YEAR 2016-2017 BUDGET OF THE DEPARTMENT OF PARKS AND RECREATION (WARD 3 & 4) (JONES & YARBER) is legally sufficient for placement in NOVUS Agenda.

James Anderson Jr., *Special Assistant to City Attorney*

DATE

OFFICE OF THE CITY ATTORNEY
6/21/17