



**REGULAR MEETING OF THE CITY COUNCIL  
CITY OF JACKSON, MISSISSIPPI**

**June 5, 2018**

**AGENDA**

**10:00 AM**

**CALL TO ORDER BY THE PRESIDENT**

**INVOCATION**

1. **PASTOR STANLEY SMITH OF CROSSROADS M.B. CHURCH**

**PUBLIC HEARING**

2. **ORDER REQUESTING THE CITY COUNCIL REVIEW AND VOTE TO APPROVE THE SIGN VARIANCE REQUEST FOR CRACKER BARREL OLD COUNTRY STORE TO REFACE THEIR EXISTING NONCONFORMING 240 SQ. FT. GROUND SIGN AT 50 FT. IN HEIGHT WITHIN A C-3 ZONE WHICH ONLY ALLOWS GROUND SIGNS TO BE 200 SQ. FT. IN SIZE AND 35 FT. IN HEIGHT. (WARD 7) (KUMAR, LUMUMBA)**
3. **ORDER REQUESTING THE CITY COUNCIL REVIEW AND VOTE TO DENY THE SIGN VARIANCE REQUEST FOR CRACKER BARREL OLD COUNTRY STORE TO REFACE THEIR EXISTING NONCONFORMING 240 SQ. FT. GROUND SIGN AT 50 FT. IN HEIGHT WITHIN A C-3 ZONE WHICH ONLY ALLOWS GROUND SIGNS TO BE 200 SQ. FT. IN SIZE AND 35 FT. IN HEIGHT. (WARD 7) (KUMAR, LUMUMBA)**

**INTRODUCTIONS**

**PUBLIC COMMENTS**

**CONSENT AGENDA**

4. **ORDER AUTHORIZING THE MAYOR TO EXECUTE A CONTRACT BETWEEN THE CITY OF JACKSON AND SMITH, ALTON D/B/A ACA DEMOLITION & PROJECT GROUP, LLC 120 HILLCROFT PLACE, JACKSON, MISSISSIPPI 39211 FOR THE DEMOLITION AND REMOVAL OF STRUCTURES(S), FOUNDATION, STEPS, DRIVEWAY, THE CUTTING OF GRASS AND WEEDS AND REMOVAL OF TRASH AND DEBRIS AND REMEDYING OF CONDITIONS ON PRIVATE PROPERTY WHICH CONSTITUTE A MENACE TO PUBLIC HEALTH, SAFETY AND WELFARE ACCORDING TO THE MISSISSIPPI CODE ANNOTATED SECTION 21-19-11. CASE #2012-2218 - 3758 NORTHVIEW DRIVE- \$3,323.00. (WARD 7) (MOORE, LUMUMBA)**

## INTRODUCTION OF ORDINANCES

5. **ORDINANCE OF THE CITY COUNCIL OF JACKSON, MISSISSIPPI RENAMING LAVERNET ROAD (FROM MARTIN LUTHER KING, JR. DRIVE TO END) TO CHARLES EVERS DRIVE. (STOKES)**
6. **ORDINANCE OF THE CITY COUNCIL OF JACKSON, MISSISSIPPI RENAMING NORTH STREET (FROM MISSISSIPPI STREET TO AMITE STREET) TO MYRLIE EVERS DRIVE. (STOKES)**

## REGULAR AGENDA

7. **CLAIMS (HATCHER, LUMUMBA)**
8. **PAYROLL (HATCHER, LUMUMBA)**
9. **ORDER REVISING THE FY2017-18 BUDGET TO INCREASE THE CITY CLERK'S VOTER ROLL BUDGET IN THE AMOUNT OF \$500,000.00 FOR ELECTION EXPENSES RELATED TO THE JACKSON PUBLIC SCHOOL'S BOND REFERENDUM. (BLAINE, LUMUMBA)**
10. **ORDER CLARIFYING PREVIOUS ORDER AUTHORIZING THE MAYOR TO EXECUTE AN AGREEMENT WITH COGENT COMMUNICATIONS TO MOVE THE CITY OF JACKSON FROM 1G OF BROADBAND ACCESS TO 10 GIG BROADBAND ACCESS. (BLAINE, LUMUMBA)**
11. **ORDER REQUESTING THE CITY COUNCIL REVIEW AND VOTE TO APPROVE THE SIGN VARIANCE REQUEST FOR CRACKER BARREL OLD COUNTRY STORE TO REFACE THEIR EXISTING NONCONFORMING 240 SQ. FT. GROUND SIGN AT 50 FT. IN HEIGHT WITHIN A C-3 ZONE WHICH ONLY ALLOWS GROUND SIGNS TO BE 200 SQ. FT. IN SIZE AND 35 FT. IN HEIGHT. (WARD 7) (KUMAR, LUMUMBA)**
12. **ORDER REQUESTING THE CITY COUNCIL REVIEW AND VOTE TO DENY THE SIGN VARIANCE REQUEST FOR CRACKER BARREL OLD COUNTRY STORE TO REFACE THEIR EXISTING NONCONFORMING 240 SQ. FT. GROUND SIGN AT 50 FT. IN HEIGHT WITHIN A C-3 ZONE WHICH ONLY ALLOWS GROUND SIGNS TO BE 200 SQ. FT. IN SIZE AND 35 FT. IN HEIGHT. (WARD 7) (KUMAR, LUMUMBA)**
13. **ORDER AUTHORIZING THE MAYOR OR DESIGNEE TO EXECUTE THE APPLICATION AND RELATED DOCUMENTS AND EXECUTE THE AGREEMENT WITH THE UNITED STATES DEPARTMENT OF TRANSPORTATION, FEDERAL TRANSIT ADMINISTRATION FOR THE DISCRETIONARY FY2018 COMPETITIVE FUNDING OPPORTUNITY FOR BUS AND BUS FACILITIES FORMULA PROGRAM SECTION 5339(C) IN THE AMOUNT OF \$6,000,000.00. (KUMAR, LUMUMBA)**
14. **ORDER ACCEPTING THE REQUEST FOR PROPOSAL OF PICADILLY HOLDING, LLC TO PROVIDE FOOD CATERING SERVICES TO THE JACKSON POLICE DEPARTMENT RECRUIT CADETS AND TRAINING STAFF. (MOORE, LUMUMBA)**
15. **ORDER AUTHORIZING THE CITY OF JACKSON TO ENTER INTO AN AGREEMENT WITH THE YAZOO CITY POLICE DEPARTMENT FOR THEIR POLICE APPLICANTS TO ATTEND THE 57TH BASIC RECRUIT CLASS. (MOORE, LUMUMBA)**

16. **ORDER AUTHORIZING THE RENEWAL AND PAYMENT OF THE ANNUAL MAINTENANCE AGREEMENT ON THE AUTOMATED FINGERPRINT IDENTIFICATION SYSTEM. (MOORE, LUMUMBA)**
17. **ORDER AUTHORIZING THE JACKSON POLICE DEPARTMENT TO PURCHASE THIRTY (30) IN-CAR RADIOS FROM MOTOROLA. (MOORE, LUMUMBA)**
18. **ORDER ACCEPTING THE TERM BIDS OF HEMPHILL CONSTRUCTION COMPANY, UTILITY CONSTRUCTORS, INC., AND DELTA CONSTRUCTORS, INC., FOR LABOR AND EQUIPMENT TO PERFORM VARIOUS PUBLIC WORKS SEWER PROJECTS. (ALL WARDS) (MILLER, LUMUMBA)**
19. **ORDER ACCEPTING THE TERM BIDS OF HEMPHILL CONSTRUCTION COMPANY, UTILITY CONSTRUCTORS, INC., AND DELTA CONSTRUCTORS, INC., FOR LABOR AND EQUIPMENT TO PERFORM VARIOUS PUBLIC WORKS WATER PROJECTS. (ALL WARDS) (MILLER, LUMUMBA)**
20. **ORDER ACCEPTING THE BID OF TECHNOLOGY INTERNATIONAL, INC. FOR LOWBOY/FLATBED TRAILER (BID NO. 07051-011618). (ALL WARDS) (MILLER, LUMUMBA)**
21. **ORDER ACCEPTING THE TERM BID OF PRECISION PACKAGING, INC., FOR A TWENTY-FOUR MONTH SUPPLY OF PORTLAND CEMENT, (BID NO. 75021-112117), FOR ALL WARDS. (MILLER, LUMUMBA)**
22. **ORDER OF CITY COUNCIL OF JACKSON, MISSISSIPPI RESCINDING THE MAY 8, 2018 ORDER AUTHORIZING THE MAYOR TO EXECUTE A PROFESSIONAL SERVICE AGREEMENT WITH RESULT BIZ FOR THE DEVELOPMENT OF AN RFP OF AN ERP SYSTEM. (STAMPS)**
23. **ORDER OF THE CITY COUNCIL OF JACKSON, MISSISSIPPI AUTHORIZING A GRANT TO SUPPORT THE MISSISSIPPI BLACK RODEO IN THE AMOUNT OF TEN THOUSAND DOLLARS (\$10,000.00). (STAMPS)**
24. **ORDER OF THE CITY COUNCIL OF JACKSON, MISSISSIPPI AUTHORIZING A GRANT TO THE JACKSON MUSIC AWARDS IN THE AMOUNT OF TEN THOUSAND DOLLARS (\$10,000.00). (STOKES)**
25. **RESOLUTION OF THE CITY COUNCIL OF JACKSON, MISSISSIPPI RECOGNIZING AND SUPPORTING THE CELEBRATION OF FATHER'S DAY, 2018. (STOKES)**
26. **RESOLUTION OF THE CITY OF JACKSON, MS IN SUPPORT OF ENTERING INTO A MARKETING LICENSE AGREEMENT WITH THE NATIONAL LEAGUE OF CITIES PARTNERING WITH UTILITY SERVICE PARTNERS, INC. ("USP") A HOMESERVE COMPANY, IN OFFERING THE NLC SERVICE LINE WARRANTY PROGRAM. (BANKS)**

#### **DISCUSSION**

27. **DISCUSSION: INTERLOCAL AGREEMENTS WITH HINDS COUNTY (PRIESTER)**

28. **DISCUSSION: PUBLIC TRANSPORTATION (STAMPS)**
29. **DISCUSSION: UPDATE ON RFP (JACKSON ZOO) (STOKES)**
30. **DISCUSSION: VIRDEN ADDITION (STOKES)**
31. **DISCUSSION: UPDATE ON RANKIN-HINDS FLOOD CONTROL DISTRICT'S FLOOD CONTROL PROJECT (LUMUMBA)**

**PRESENTATION**

**PROCLAMATION**

**RESOLUTIONS**

32. **RESOLUTION OF THE CITY COUNCIL OF JACKSON, MISSISSIPPI HONORING AND COMMENDING MR. JOHNNY E. DAVIS AS AN OUTSTANDING CITIZEN AND FATHER OF THE YEAR. (STOKES)**

**REPORT FROM MEMBERS, MAYOR, DEPARTMENT DIRECTORS**

**ANNOUNCEMENTS**

**ADJOURNMENT**

**AGENDA ITEMS IN COMMITTEE**

## **ALL ITEMS IN COMMITTEE**

### **FINANCE**

1. Order of the City Council of Jackson, Mississippi authorizing an across the board pay raises for City employees for FY 2014-2015. (Cooper-Stokes) (07/01/14)
2. Ordinance establishing responsible banking and community reinvestment practices within the City of Jackson. (Stamps) (08/12/14)
3. Order of the City Council of Jackson, Mississippi authorizing the retention of professional services to assist with the budget preparation for FY2016. (Stokes) (08/25/15)
4. Order revising unrestricted general fund reserve policy. (Stokes) (06/14/16)
5. Order of the City Council of Jackson, Mississippi authorizing the placement of two million dollars from the fund balance of the City budget to be transferred to the City of Jackson Police Department's budget. (Stokes) (11/01/16)

### **ECONOMIC DEVELOPMENT**

1. Discussion: Joint Economic strategies for the Metrocenter by the City of Jackson and Hinds County (Tillman) (11/10/14)
2. Discussion: Costco (Yarber) (06/02/15)
3. Discussion: The Landmark Building (Yarber) (06/02/15)
4. Discussion: Farish Street (Yarber) (06/02/15)
5. Ordinance of the City Council of Jackson, Mississippi establishing the Business Development Fund within the City of Jackson. (Hendrix) (10/08/15)
6. Discussion: Black on Black Crime (Stamps) (04/04/17)
7. Order authorizing the Mayor to accept the transfer of ownership of the Jackson Multimodal Transportation Facility, commonly known as Union Station, from the Jackson Redevelopment Authority to the city of Jackson. (Stokes) (07/18/17)

## **ALL ITEMS IN COMMITTEE**

### **EDUCATION**

1. Resolution of the City Council of Jackson, Mississippi in opposition to locating charter schools in public schools that are currently in operation. (Cooper-Stokes) (04/08/14)

### **LEGISLATIVE**

1. Resolution urging the Department of Housing and Urban Development to enact safeguards against abuses in contracts for deeds. (Stamps) (11/21/17)
2. Resolution calling on the federal, state, and local religious freedom and civil rights. (Stamps) (11/21/17)
3. Resolution supporting the expansion of the earned income tax credit for working childless adults. (Stamps) (11/21/17)
4. Resolution of the City Council of Jackson, Mississippi requesting the Governor to call a Special Session of the Mississippi State Legislature to deal with increased funding and treatment for mental patients in the State of Mississippi. (Stokes) (03/07/18)

### **PLANNING**

1. Ordinance amending re-enacting a City of Jackson Curfew Ordinance, Chapter 86, Article II, of the Code of Ordinances City of Jackson, Mississippi to establish a curfew applicable to juveniles to within the City of Jackson. (Stokes) (07/26/11)
2. Ordinance of the City Council of Jackson, Mississippi renaming Amite Street (from Gallatin Street to Robinson Street) to Dr. John M. Perkins Drive. (Stokes) (08/24/10)
3. Ordinance of the City Council of Jackson, Mississippi renaming of Cleary Street (from Dalton Street to the Dead End) to Rev. Dr. Emmett C. Burns, Jr. Drive. (Stokes) (09/06/11)
4. Ordinance of the City Council of Jackson, Mississippi establishing the honorary renaming of Medgar Evers Blvd. (from Ridgeway Street to Martin Luther King, Jr. Drive) to Reverend Curtis W. Houston Drive. (Cooper-Stokes) (07/10/12)
5. Ordinance of the City Council of Jackson, Mississippi requiring sprinkler systems in buildings housing flammable materials. (Cooper-Stokes) (09/4/112)
6. Resolution of the City Council of Jackson, Mississippi encouraging the enhanced use of cell phone towers in the City. (Cooper-Stokes) (01/14/14)

## ALL ITEMS IN COMMITTEE

7. Ordinance amending the 2008 amendment to the Capital City Smoke-Free Air Ordinance of 2003, codified as Chapter 86, Article VI, of the Code of Ordinances, City of Jackson, Mississippi. (Whitwell) (01/14/14)
8. Ordinance of the City Council of Jackson, Mississippi to rename two streets: Gun Street for Albert Barber, Jr. and Hume Street for Jason Murphy, two teenage African American males who were double homicide victims in the City of Jackson in July 2013. (Cooper-Stokes) (03/11/14)
9. Discussion Item: City Land Bank Operations (Stamps) (03/25/14)
10. Ordinance of the City Council of Jackson, Mississippi renaming Battlefield Park in honor of the late Jackson Mayor Chokwe Lumumba. (Cooper-Stokes) (08/14/14) & (11/18/14)
11. Ordinance of the City Council of Jackson, Mississippi regulating the operation of drones in the city limits and requiring the registration of drones. (Cooper-Stokes) (09/09/14)
12. Ordinance of the City Council of Jackson, Mississippi requiring no-touch temperature checks of passengers arriving at City-owned airports. (Cooper-Stokes) (10/30/14)
13. Ordinance of the City Council of Jackson, Mississippi requiring the closure of nuisance nightclubs. (Cooper-Stokes) (11/04/14)
14. Ordinance of the City Council of Jackson, Mississippi requiring security personnel at convenience stores during hours of operation. (Cooper-Stokes) (11/04/14)
15. Discussion: Parking meters and parking in downtown Jackson (Priester) (02/24/15)
16. Ordinance of the City Council of Jackson, Mississippi renaming Gymnasium Drive (from Bullard Street to Dead end) to James Rice, Jr. Drive. (Stokes) (10/06/15)
17. Ordinance of the City Council of Jackson, Mississippi regulating public accommodations for restroom facilities. (Stokes) (11/03/15)
18. Ordinance of the City Council of Jackson, Mississippi renaming Flag Chapel Road (from Clinton Boulevard to Northside Drive) to President Barack Obama Drive. (Stamps) (01/12/16)
19. Ordinance of the City Council of Jackson, Mississippi establishing the renaming of Valley Street from Highway 80 to Raymond Rd. to Rev. Dr. R.L.T. Smith Drive. (Stokes) (02/09/16)
20. Ordinance of the City Council of Jackson, Mississippi regulating the annual water sampling of Municipal water for the detection of contaminants of lead or copper. (Hendrix, Stamps) (02/09/16)

## ALL ITEMS IN COMMITTEE

21. Ordinance of the City of Jackson, Mississippi amending Chapter 126 of the Jackson Municipal Code of Ordinances to modernize the regulation of vehicles for hire of the City of Jackson, Mississippi. (Priester) (03/10/16)
22. Ordinance of the City Council of Jackson, Mississippi naming the downtown Jatran Bus Transfer Station in honor of Mrs. Rosa Parks. (Stokes) (04/19/16)
23. Ordinance of the City Council of Jackson, Mississippi renaming Morris Street (from Jefferson Street to Commerce Street to Corrice Collins Drive). (Stokes) (04/19/16)
24. Order authorizing a one year moratorium on certain new business licenses in the City of Jackson. (Stamps) (05/03/16)
25. Ordinance of the City Council of Jackson, Mississippi renaming Tombigbee Street (from Congress Street to West Street) to Travis E. Knight Drive. (Stokes) (07/12/16)
26. Ordinance of the City Council of Jackson, Mississippi renaming a portion of Ridgeway Street (from Bailey Avenue to the Dead End) to Doug L. Anderson Street. (Stokes) (08/23/16)
27. Order requesting the City Council review and vote to approve the sign variance request for Jackson Public Schools to erect a 726 sq. ft. LED Billboard within a SUD zone which does not allow billboards. (Jefferson, Yarber) (09/06/16)
28. Order requesting the City Council review and vote to deny the sign variance request for Jackson Public Schools to erect a 726 sq. ft. LED Billboard within a SUD zone which does not allow billboards. (Jefferson, Yarber) (09/06/16)
29. Order requesting the City Council review and vote to approve the sign variance request for Jackson Public Schools to erect a three sided/faced LED Billboard within a SUD zone which does not allow there sided/faced billboard. (Jefferson, Yarber) (09/06/16)
30. Order requesting the City Council review and vote to deny the sign variance request for Jackson Public Schools to erect a three sided/faced LED Billboard within a SUD zone which does not allow there sided/faced billboard. (Jefferson, Yarber) (09/06/16)
31. Ordinance of the City Council of Jackson, Mississippi requiring security personnel at convenience stores during hours of operations from 12:00 a.m. to 6:00 a.m. (Stokes) (10/18/16)
32. Ordinance of the City Council of Jackson, Mississippi establishing the renaming of Vardaman Street (from Bailey avenue to Bailey Avenue Extension) to Al Joyner Way. (Stokes) (11/01/16)



## ALL ITEMS IN COMMITTEE

33. Order rescinding the ordinance of the City Council of Jackson, Mississippi renaming Langley Avenue (from Silas Brown Street to Winter Street) to Dr. Raymond O. Baird Drive. (Stamps) (11/01/16)
34. Ordinance of the City Council of Jackson, Mississippi establishing a five dollar per room rental fee for hourly motel rentals. (Stokes) (11/15/16)
35. Ordinance of the City Council of Jackson, Mississippi establishing the renaming of Pearl Street (from Dalton to Prentiss Street) to Coach Paul Covington Drive. (Stokes) (12/27/16)
36. Ordinance of the City Council of Jackson, Mississippi renaming Bailey Avenue (from Bailey Avenue Extension to Woodrow Wilson) to Tommie Hathorn Way. (Stokes) (12/27/16)
37. Ordinance of the City Council of Jackson, Mississippi to regulate security at apartments with 25 or more rental units. (Stokes) (02/21/17)
38. Ordinance of the City Council of Jackson, Mississippi naming Road of Remembrance Park as Alfredteen Brown Harrison Park. (Stokes) (03/07/17)
39. Ordinance amending Chapter 102 – Signs, Article II. Sign regulations, Section 102-32, Prohibited signs, of the Code of Ordinances of the City of Jackson, Mississippi to prohibit any outdoor sign that contains any message or depiction of a sexually explicit nature. (Stamps) (03/07/17)
40. Ordinance of the City Council of Jackson, Mississippi renaming Pear Street to Reverend Jesse Sutton, Jr. Street. (Stamps) (04/04/17)
41. Ordinance of the City Council of Jackson, Mississippi renaming Carnes Street (from Palmyra Street to Martin Luther King, Jr., Dr.) to Reverend Alvin Burton, Sr. Street. (Stokes) (04/18/17)
42. Ordinance of the City Council of Jackson, Mississippi renaming Cohea Street (from Palmyra Street to Lamar Street) to Corporal Allen Harper, Jr., Street. (Stokes) (04/18/17)
43. Ordinance of the City Council of Jackson, Mississippi renaming Todd Street (from Palmyra Street to Martin Luther King, Jr. Dr.) to Andre Lamont Jones Street. (Stokes) (04/18/17)
44. Order declaring parcel 73-26 surplus property and authorizing disposal of same to River Place, LLC for development of housing. (Jefferson, Yarber) (06/13/17)
45. Order declaring parcel 72-56 surplus property and authorizing disposal of same to River Place, LLC for development of housing. (Jefferson, Yarber) (06/13/17)

## ALL ITEMS IN COMMITTEE

46. Order declaring parcel 72-37 surplus property and authorizing disposal of same to River Place, LLC for development of housing. (Jefferson, Yarber) (06/13/17)
47. Order declaring parcel 73-29-1 surplus property and authorizing disposal of same to River Place, LLC for development of housing. (Jefferson, Yarber) (06/13/17)
48. Order declaring parcel 72-58 surplus property and authorizing disposal of same to River Place, LLC for development of housing. (Jefferson, Yarber) (06/13/17)
49. Order declaring parcel 72-52 surplus property and authorizing disposal of same to River Place, LLC for development of housing. (Jefferson, Yarber) (06/13/17)
50. Order declaring parcel 72-55 surplus property and authorizing disposal of same to River Place, LLC for development of housing. (Jefferson, Yarber) (06/13/17)
51. Order declaring parcel 73-22 surplus property and authorizing disposal of same to River Place, LLC for development of housing. (Jefferson, Yarber) (06/13/17)
52. Ordinance of the City Council of Jackson, Mississippi establishing the honorary renaming of Capitol Street from Gallatin Street to State Street to Williams Brothers Drive. (Stokes) (08/29/17)
53. Ordinance of the City Council of Jackson, Mississippi establishing the renaming of Brame Street (from Northside Drive to the Dead End of Eubanks Creek) to Bishop Hollis Musgrove Drive. (Stokes) (08/29/17)
54. Ordinance of the City Council of Jackson, Mississippi establishing the renaming of Kimball Avenue (from Sunset Drive to Liberty Street) to Johnetta Jurden Drive. (Stokes) (08/29/17)
55. Order authorizing the Mayor to execute an agreement with BFAC.Com for the purchase and maintenance of a mobile app service and design. (Hatcher, Lumumba) (10/10/17)
56. Ordinance of the City Council of Jackson, Mississippi establishing the renaming of Livingston Road (from Five Points Medgar Evers Boulevard at Woodrow Wilson Drive to Northside Drive) to Dr. Aaron Shirley Drive. (Stokes) (11/21/17)
57. Ordinance of the City Council of Jackson, Mississippi establishing the renaming of Hamilton Street (from Mill Street to West Street) to Charles W. Tisdale Drive. (Stokes) (11/21/17)
58. Discussion: Sign Ordinance (Stokes) (12/5/17)

## **ALL ITEMS IN COMMITTEE**

59. Ordinance of the City Council of Jackson, Mississippi renaming Sunray Drive (in its entirety) to Willie Lindsey, Jr. Drive. (Stamps) (02/27/18)
60. Ordinance of the City Council of Jackson, Mississippi establishing the honorary renaming of Carnation Street (from Pocahontas Avenue to Holmes Avenue) to Reverend Frank Wilbert James Drive. (Stokes) (02/27/18)
61. Resolution of the City Council of Jackson, Mississippi supporting the reopening of Lake Hico. (Stokes) (02/27/18)
62. Ordinance of the City Council of Jackson, Mississippi establishing and regulating the collection and use of video from JPD body cameras. (Stokes) (03/27/18)
63. Ordinance of the City Council of Jackson, Mississippi regulating the unlawful threatening, menacing, or disturbing the work of the City of Jackson employees by anyone while in the performance of their duties. (Stokes) (05/08/18)

## **RULES**

1. Discussion: Council Decorum (Lindsay) (03/27/18)
2. Ordinance of the City Council of Jackson, Mississippi to amend the Code of Ordinances of the Internal Audit Committee. (Banks) (04/24/18)
3. Ordinance of the City Council of Jackson, Mississippi to amend the Jackson Code of Ordinances to establish the office and function of the Internal Auditor as a separate and independent office. (Banks) (04/24/18)
4. Resolution of the City Council of Jackson executing a vote of no confidence in the company: Veolia North America. (Banks) (05/08/18)

## **GOVERNMENT OPERATIONS**

1. Discussion: Minority participation (Stokes) (06/02/15)
2. Discussion: 21<sup>st</sup> Century policing (Stamps) (06/02/15)
3. Discussion: EBO (Yarber) (06/02/15)
4. Ordinance of the City Council of Jackson, Mississippi amending Chapter 2 Administration, Article IV, Departments, Section 2-336, of the Code of Ordinances of the City of Jackson, Mississippi to delete Constituents Services and Information as a department and to remove Youth Court as a principal function of police. (Stamps) (09/06/16)

## ALL ITEMS IN COMMITTEE

5. Ordinance amending Section 2-325 of the Jackson Code of Ordinances to include qualifications for the position of Chief Administration Officer. (Stamps) (11/1/16)
6. Order authorizing the Mayor to accept the transfer of ownership of the Jackson Multimodal Transportation Facility, commonly known as Union Station, from the Jackson Redevelopment Authority to the City of Jackson. (Stokes) (07/18/17)
7. Discussion: Officer Involved Shootings (Stamps) (02/27/18)
8. Discussion: Cash Bonds (Stamps) (02/27/18)

OFFICE OF THE CITY ATTORNEY  
4/24/18

**ORDER REQUESTING THE CITY COUNCIL REVIEW AND VOTE TO APPROVE THE SIGN VARIANCE REQUEST FOR CRACKER BARREL OLD COUNTRY STORE TO REFACE THEIR EXISTING NONCONFORMING 240 SQ. FT. GROUND SIGN AT 50 FT. IN HEIGHT WITHIN A C-3 ZONE WHICH ONLY ALLOWS GROUND SIGNS TO BE 200 SQ. FT. IN SIZE AND 35 FT. IN HEIGHT (WARD 7)**

**WHEREAS**, the public health, safety or general welfare of the community may require that variances be granted in specific cases as set forth in City of Jackson Sign Ordinance, Sections 102-26, et seq., of the City of Jackson Code of Ordinances; and

**WHEREAS**, pursuant to Section 102-40, no action by the City Council may be taken concerning a variance from the sign regulations until after a public hearing in relation thereto, at which parties in interest and the general citizenry shall have an opportunity to be heard; and

**WHEREAS**, no variance from the Sign Ordinance shall be passed by the City Council unless and until an application seeking the variance is filed with the City's Signs and License Division, with such application containing, at a minimum, a legal description, location map, plot plan, the exact nature of the requested variance, the grounds upon which it is requested, and/or such other information as may be required by the Signs and License Division manager; and

**WHEREAS**, said variance application shall also demonstrate that:

1. Special conditions and circumstances exist which are peculiar to the land, structure, or building involved and which are not applicable to other lands, structures, or buildings in the same district;
2. The literal interpretation of the provisions of the Sign Ordinance would deprive the applicant of rights commonly enjoyed by other properties in the same district under the provisions of the Sign Ordinance;
3. The special conditions and circumstances do not result from actions of the applicant; and
4. Granting the variance requested will not confer upon the applicant any special privilege that is denied by the Sign Ordinance to other similar lands, structures, or buildings in the same district; and

**WHEREAS**, Cracker Barrel Old Country Store, the applicant herein, has requested a variance from the Sign Ordinance regulations to reface their existing nonconforming 240 sq. ft. ground sign at 50 ft. in height within a C-3 zone which only allows ground signs to be 200 sq. ft. in size and 35 ft. in height.

**IT IS THEREFORE, ORDERED** that Cracker Barrel Old Country Store is hereby (*approved*) a variance from the Sign Ordinance regulations to reface their existing nonconforming 240 sq. ft. ground sign at 50 ft. in height within a C-3 zone which only allows ground signs to be 200 sq. ft. in size and 35 ft. in height.

**IT IS FURTHER ORDERED** that the City Council has considered the variance application and grants the variance requested therein based on a finding that special conditions and circumstances exist which are peculiar to the land, structure, or building involved and which are not applicable to other lands, structures, or buildings in the same district; the literal interpretation of the provision of the Sign Ordinance (*would*) deprive the applicant of rights commonly enjoyed by other properties in the same district under the provisions of the Sign Ordinance; the special conditions and circumstances do not result from actions of the applicant; and granting the variance requested (*will not*) confer upon the applicant any special privilege that is denied by the Sign Ordinance to other similar lands, structures, or buildings in the same district.

Item#

Date:

By: Coleman, Kumar, Lumumba

**CITY COUNCIL AGENDA ITEM 10 POINT DATA SHEET**

04/17/18

DATE

<b>POINTS</b>		<b>COMMENTS</b>	
1.	<b>Brief Description/Purpose</b>	To reface their existing nonconforming 240 sq. ft. ground sign at 50 ft. in height within a C-3 zone which only allows ground signs to be 200 sq. ft. in size and 35 ft. in height.	
2.	<b>Public Policy Initiative</b> 1. Youth & Education 2. Crime Prevention 3. Changes in City Government 4. Neighborhood Enhancement 5. Economic Development 6. Infrastructure and Transportation 7. Quality of Life	N/A	
3.	<b>Who will be affected</b>	N/A	
4.	<b>Benefits</b>	N/A	
5.	<b>Schedule (beginning date)</b>	N/A	
6.	<b>Location:</b> ■ WARD ■ CITYWIDE (yes or no) (area) ■ Project limits if applicable	6020 I-55 N WARD 7	
7.	<b>Action implemented by:</b> ■ City Department <input checked="" type="checkbox"/> ■ Consultant <input type="checkbox"/>	Department of Planning & Development Signs & License Division	
8.	<b>COST</b>	N/A	
9.	<b>Source of Funding</b> ■ General Fund <input type="checkbox"/> ■ Grant <input type="checkbox"/> ■ Bond <input type="checkbox"/> ■ Other <input type="checkbox"/>	N/A	
10.	<b>EBO participation</b>	ABE _____%      WAIVER    yes ___ no ___      N/A <u>  X  </u> AABE _____%      WAIVER    yes ___ no ___      N/A <u>  X  </u> WBE _____%      WAIVER    yes ___ no ___      N/A <u>  X  </u> HBE _____%      WAIVER    yes ___ no ___      N/A <u>  X  </u> NABE _____%      WAIVER    yes ___ no ___      N/A <u>  X  </u>	

Department of Planning and Development



200 South President Street  
Post Office Box 17  
Jackson, Mississippi 39205-0017

## MEMORANDUM

**TO:** Mayor Chokwe Antar Lumumba

**FROM:** Dr. Mukesh Kumar, Director *mkc*  
Department of Planning & Development

**DATE:** April 17, 2018

**RE:** Sign Variance

---

Cracker Barrel Old Country Store, located at 6020 I-55 N, is requesting a variance to reface their existing nonconforming 240 sq. ft. ground sign at 50 ft. in height within a C-3 zone which only allows ground signs to be 200 sq. ft. in size and 35 ft. in height.



Office of the City Attorney

455 East Capitol Street  
Post Office Box 2779  
Jackson, Mississippi 39207-2779  
Telephone: (601) 960-1799  
Facsimile: (601) 960-1756

## OFFICE OF THE CITY ATTORNEY

This ORDER REQUESTING THE CITY COUNCIL REVIEW AND VOTE TO **APPROVE** THE SIGN VARIANCE REQUEST FOR CRACKER BARREL OLD COUNTRY STORE TO REFACE THEIR EXISTING NONCONFORMING 240 SQ. FT. GROUND SIGN AT 50 FT. IN HEIGHT WITHIN A C-3 ZONE WHICH ONLY ALLOWS GROUND SIGNS TO BE 200 SQ. FT. IN SIZE AND 35 FT. IN HEIGHT (WARD 7) is legally sufficient for placement in NOVUS Agenda.

  
\_\_\_\_\_  
**Sharon D. Gipson**, *City Attorney*

**Dana Sims**, *Deputy City Attorney* 

  
\_\_\_\_\_  
DATE

RECEIVED

APR 02 2018

SIGN AND LICENSE DIVISION

PAID  
APR 02 2018  
450.00 CLK2653  
SIGNS & LICENSE  
K. Eastley

FOR OFFICE USE ONLY

CASE NO.: \_\_\_\_\_

CITY OF JACKSON, MS

Application for Sign Variance

I. Subject Property Address: 6020 I-55 NORTH, JACKSON, MS

II. Purpose for requested Sign Variance: (Brief Description)

PLEASE SEE ATTACHED

III. Have you or any other individual been cited for or notified of any ordinance violations related to this property or business? No  
If yes, please give details and dates of violations:

IV. Are there any Restrictive Covenants? No If yes, please attach copies

V. What is the Zoning classification of property? C-3 (GENERAL COMMERCIAL)  
If yes, please attach copies of agency findings and decisions.

VI. APPLICANT'S INFORMATION:

Name: CRACKER BARREL OLD COUNTRY STORE

Mailing Address: P.O. Box 787

City: LEBANON State: TN Zip: 37088

Contact Phone: 615-443-9373 Fax: 615-443-9895

Email: TINA.BEASLEY@CRACKERBARREL.COM

RECEIVED

APR 02 2018

SIGN AND LICENSE DIVISION

VII. APPLICANT WILL BE REPRESENTED BY:

Name: RICHARD FRANKEL C/O ELROD ENGINEERING  
Mailing Address: 871 SEVEN OAKS BLVD, STE 220  
City: SMYRNA State: TN Zip: 37167  
Contact Phone: 615-512-8220 Fax: 615-890-3580  
Email: rf@elrodllc.com

VIII. CURRENT PROPERTY OWNER(S):

Name: CRACKER BARREL Old Country Store  
Mailing Address: P.O. Box 787  
City: HERSAND State: TN Zip: 37088  
Email: TINA.BEASLEY@CRACKERBARREL.COM

IX. APPLICATION FEE SCHEDULE: \*fees are non-refundable after public hearing

Variance(s) \$450.00

RECEIVED

APR 12 2018

SIGN AND LICENSE DIVISION

DECLARATION:

By signing this application, it is understood and agreed that permission is hereby given the duly authorized representative of the City of Jackson to make an investigation of the need for the sign variance request. It is further understood that the Sign & License Manager and staff may inspect the subject property, make photographs and obtain any verifications and data necessary for preparation of its report to the City Council.

The above information is true and complete to the best of my knowledge.

\_\_\_\_\_ Tina Boastey 3/5/18

WITNESS THE SIGNATURE(S) of the owner(s) of the subject property located at

6020 ISS N Jackson, Mississippi

On this the 5<sup>th</sup> day of March, 2018.

~~STATE OF MISSISSIPPI~~ State of Tennessee  
~~COUNTY OF HINDS~~ County of Wilson

Personally came and appeared before me, the within named:

\_\_\_\_\_ Tina Boastey

Who signed and delivered the above and foregoing instrument as and for their free act and deed on the day and year therein mentioned, and who acknowledge to me that they are the owner(s) of the subject property as described in this Sign Variance Application.

GIVEN UNDER MY HAND AND OFFICIAL SEAL OF OFFICE, this the 5<sup>th</sup>

Day of March, 2018.

MY COMMISSION EXPIRES:  
12/22/21

Charlotta N. Nokes  
NOTARY PUBLIC



RECEIVED

APR 12 2018

City of Jackson, MS  
Application for Sign Variance

SIGN AND LICENSE DIVISION

II. Purpose for requested Sign Variance: (Brief Description)

Cracker Barrel Old Country Store, located at 6020 Interstate 55 North Frontage Road, initially sought to replace, one-for-one, the cabinet of the sign located on the front of the property. The existing 240 square foot cabinet and support structure are 50 feet overall height. The current Jackson codes restricts signs in this district to 200 square feet at 35 feet overall height. To reduce the sign height to the current standards would limit the visibility of the sign and therefore negatively impact the flow of business to the Cracker Barrel store.

Cracker Barrel is willing to compromise with the city by reducing the cabinet size to 200 square feet, but respectfully requests the overall height of the sign remain at 50 feet.

*Joe Beasley*  
Identity Coordinator  
Cracker Barrel Old Country Store, Inc.

STATE OF TENNESSEE

COUNTY OF Wilson

On this day personally appeared before me Charlotte Nokes, to me known to be the individual who executed the within and foregoing instrument, and acknowledged that she signed the same as her free and voluntary act and deed, for the uses and purposes therein mentioned.

Given under my hand and seal of office this 12<sup>th</sup> day of April, 2018.

Printed Name: Charlotte H. Nokes  
My Commission Expires 12/22/2021



Department of Planning and Development



200 South President Street  
Post Office Box 17  
Jackson, Mississippi 39205-0017

April 18, 2018

Elrod Engineering  
Richard Frankel  
871 Seven Oaks Blvd, Suite 220  
Smyrna, TN 37167

Re: Cracker Barrel Old Country Store Sign Variance Application

Dear Mr. Frankel:

Just wanted to inform you that our office is currently working on the sign variance request that you submitted on behalf of Cracker Barrel Old Country Store located at 6020 I-55 N.

During the review and processing time of your sign variance request we are required to inform the applicant or the applicant's representative of the staff's recommendation for this sign variance request. Your application and supporting documents indicate that Cracker Barrel Old Country Store is requesting to reface their existing nonconforming 240 sq. ft. ground sign at 50 ft. in height within a C-3 zone which only allows ground signs to be 200 sq. ft. in size and 35 ft. in height.

The staff's recommendation is for approval of your sign variance request.

Sincerely,

A handwritten signature in cursive script that reads "Terry Coleman".

Terry Coleman, Manager  
Signs & License Division



RECEIVED

APR 02 2018

APPLICATION FOR SIGN PERMIT
CITY OF JACKSON
DEPARTMENT OF PLANNING AND DEVELOPMENT
SIGN AND LICENSE DIVISION
200 S. PRESIDENT STREET-JACKSON, MS 39201
601-960-1154

SIGN AND LICENSE DIVISION

DATE RECEIVED IN OFFICE:

Form with sections: CONTRACTOR/ERECTOR, LOCATION/ADDRESS OF SIGN, GROUND-MOUNTED, BUILDING-MOUNTED, TYPE OF LIGHTING, WORDING ON SIGN(S), ZONING CLASS, and checkboxes for Temporary Banner, Plot Drawings, Sign Drawings.

I hereby certify that I have read this application and that all information contained herein is true and correct; that I agree to comply with all City Ordinances, Codes, and State Laws regulating sign construction; that I am the owner or authorized to act as the owner's agent for the herein described work.

[Signature]
Applicant's Signature

03-28-2018
Date

\_\_\_\_\_  
Sign and License Division Manager

## WARRANTY DEED

FOR AND IN CONSIDERATION, of the sum of Ten Dollars (\$10.00), cash in hand paid, and other good and valuable considerations, the receipt and sufficiency all of which is hereby acknowledged, the undersigned, Mattiace Properties, Inc., a Mississippi corporation, Grantor, does hereby sell, convey and warrant unto Cracker Barrel Old Country Store, Inc., a Tennessee corporation, Grantee, the following land and property situated in the City of Jackson, Hinds County, State of Mississippi, to-wit:

Part of the Southeast 1/4 of the Southeast 1/4 of Section 1, Township 6 North, Range 1 East, Jackson, Hinds County, Mississippi and described as follows:

Begin at a point that is 428.2 feet North of and 1,120.63 feet West of the Southeast Corner of said Section 1, said Point of Beginning is on the present Easterly Right of Way Line of I-55; from said Point of Beginning run thence along said Right of Way line the following: North 8° 00' East, a distance of 242.67 feet; thence along a curve to the left having a radius of 4,609.66 feet a distance of 123.53 feet said curve has a chord of North 7° 14' 24" East, a distance of 123.53 feet; thence South 67° 33' 25" East, a distance of 50.95 feet; thence leaving said right of way line run South 1° 49' West, a distance of 13.25 feet; thence South 88° 11' East, a distance of 303.85 feet; thence South 4° 00' West, a distance of 350.98 feet; thence South 1° 06' West, a distance of 183.7 feet to the Northerly Right of Way Line of Adkins Boulevard; thence North 77° 38' West, along said Right of Way Line a distance of 50.98 feet; thence North 1° 06' East, a distance of 200.3 feet; thence North 89° 38' West, a distance of 325.76 feet to the Point of Beginning, containing 131,172.84 square feet or 3.0113 acres.

## LESS AND EXCEPT:

Begin at a point that is 428.2 feet north of and 1120.63 feet west of the Southeast corner of said Section 1, said Point of Beginning is on the present easterly right of way line of I-55; from said Point of Beginning run thence North 8° 00' East, along said right of way line a distance of 30.0 feet; thence South 89° 38' East, a distance of 50.0 feet; thence South 8° 00' West, a distance of 30.0 feet; thence North 89° 38' West, a distance of 50.0 feet to the Point of Beginning, containing 1486.7 square feet or 0.03 acres, more or less.

This conveyance is made subject to and there is excepted from the warranty hereof the following:

1. Any prior reservation or conveyance, together with release of damages, of minerals of every kind and character, including, but not limited to, oil, gas, sand, and gravel in, on, and under subject property.
2. Reservation of Perpetual Easement for ingress and egress over 50' X 183.7' strip as described in instrument recorded in Book 3694 at Page 22 in the office of the Chancery Clerk of Hinds County at Jackson, Mississippi.
3. 10' Easement for Utilities along the East side of subject parcel et al for the benefit of owner of lands North of and adjacent to subject parcel as recorded in Book 2080 at Page 370 and, also, Book 2080 at Page 437 in the office of the aforesaid Chancery Clerk.
4. Temporary Easement to the State Highway Commission of Mississippi dated October 27, 1982, for a term of 10 years as



recorded in Book 2870 at Page 353 in the office of the aforesaid Chancery Clerk.

5. Release of Damages to the State Highway Commission of Mississippi as recorded in Book 2870 at Page 355 and Book 2870 at Page 1171 in the office of the aforesaid Chancery Clerk.

6. Release of Damages etc. to the State Highway Commission of Mississippi as recorded in Book 1030 at Page 516, Book 1046 at Page 479, Book 2870 at Page 1171 and Book 2870 at Page 1173 in the office of the aforesaid Chancery Clerk.

Ad valorem taxes for the current year have been prorated between Grantors and Grantee on an estimated basis. When said taxes are actually determined, if the proration as of this date is incorrect, then Grantors agree to pay Grantee any additional amounts due, and Grantee agrees to pay Grantors any amounts overpaid. Grantee assumes and agrees to pay ad valorem taxes for all subsequent years.

WITNESS OUR SIGNATURE, this the 25<sup>th</sup> day of October, 1991.

RECEIVED

APR 02 2018

MATTIACE PROPERTIES, INC.,  
a Mississippi corporation

BY: [Signature]  
T. Andrew Mattiace, President

SIGN AND LICENSE DIVISION

ADDRESS OF GRANTOR:

Mattiace Properties, Inc.  
1818 Crane Ridge Drive  
Jackson, Mississippi 39216  
ATTENTION: T. Andrew Mattiace  
BUSINESS PHONE: (601) 982-1820  
RESIDENCE PHONE: None

ADDRESS OF GRANTEE:

Cracker Barrel Old Country  
Store, Inc.  
P. O. Box 787  
Hartman Drive  
Lebanon, Tennessee 37088-0787  
ATTENTION: V. P. Development  
BUSINESS PHONE: (615) 444-5533  
RESIDENCE PHONE: None

STATE OF MISSISSIPPI

COUNTY OF HINDS

Personally appeared before me, the undersigned authority in and for the said county and state, on this 25<sup>th</sup> day of October, 1991, within my jurisdiction, the within named T. Andrew Mattiace, duly identified before me, who acknowledged that he is President of Mattiace Properties, Inc., a Mississippi corporation, and that for and on behalf of said corporation, and as its act and deed, he executed the above and foregoing instrument, after first having been duly authorized by said corporation so to do.

[Signature]  
NOTARY PUBLIC

My Commission Expires:  
My Commission Expires April 23, 1993

(Affix official seal)



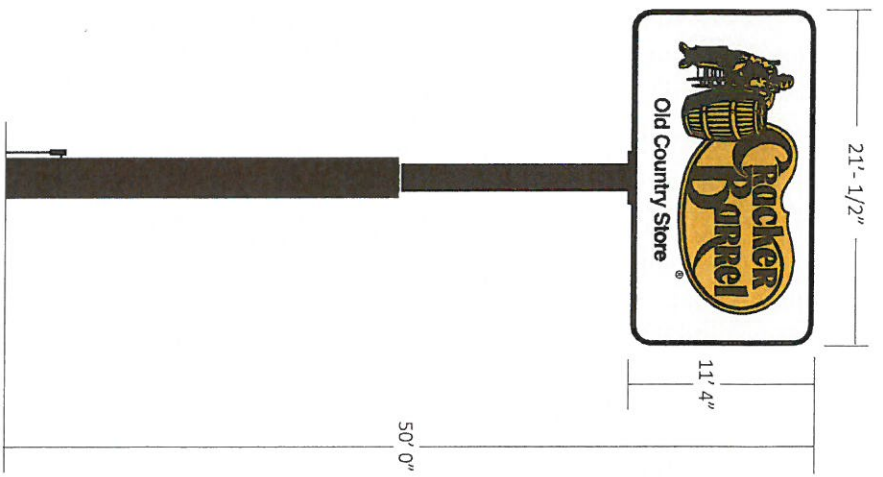

**240sf @ 50'-0"**  
Existing Flex Face Sign

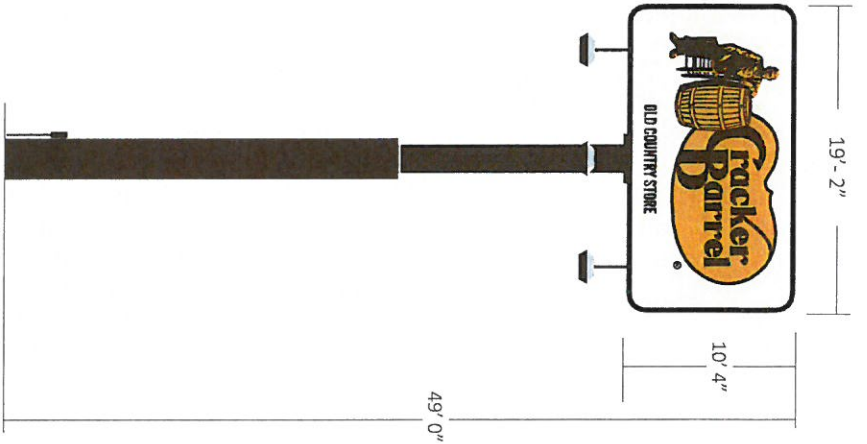

**200sf @ 50'-0"**  
Porcelain Face  
Variance Proposed

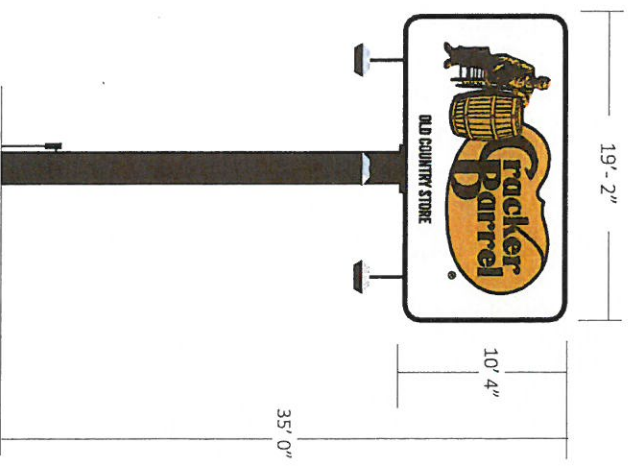

**200sf @ 35'-0"**  
Porcelain Face  
Current Sign Codes

**RECEIVED**

**APR 02 2018**

Store #CB139  
6020 I-55 North  
Jackson, MS

SIGN AND LICENSE DIVISION

**E. ELEROD**  
ENGINEERING  
871 Seven Oaks Blvd, Suite 220  
Smyrna, TN 37167  
615.890.9405

SCALE:	NTS	NO:	200sf PF X3624
DATE:	3/2/2018	REVISION:	REVISION DATE:

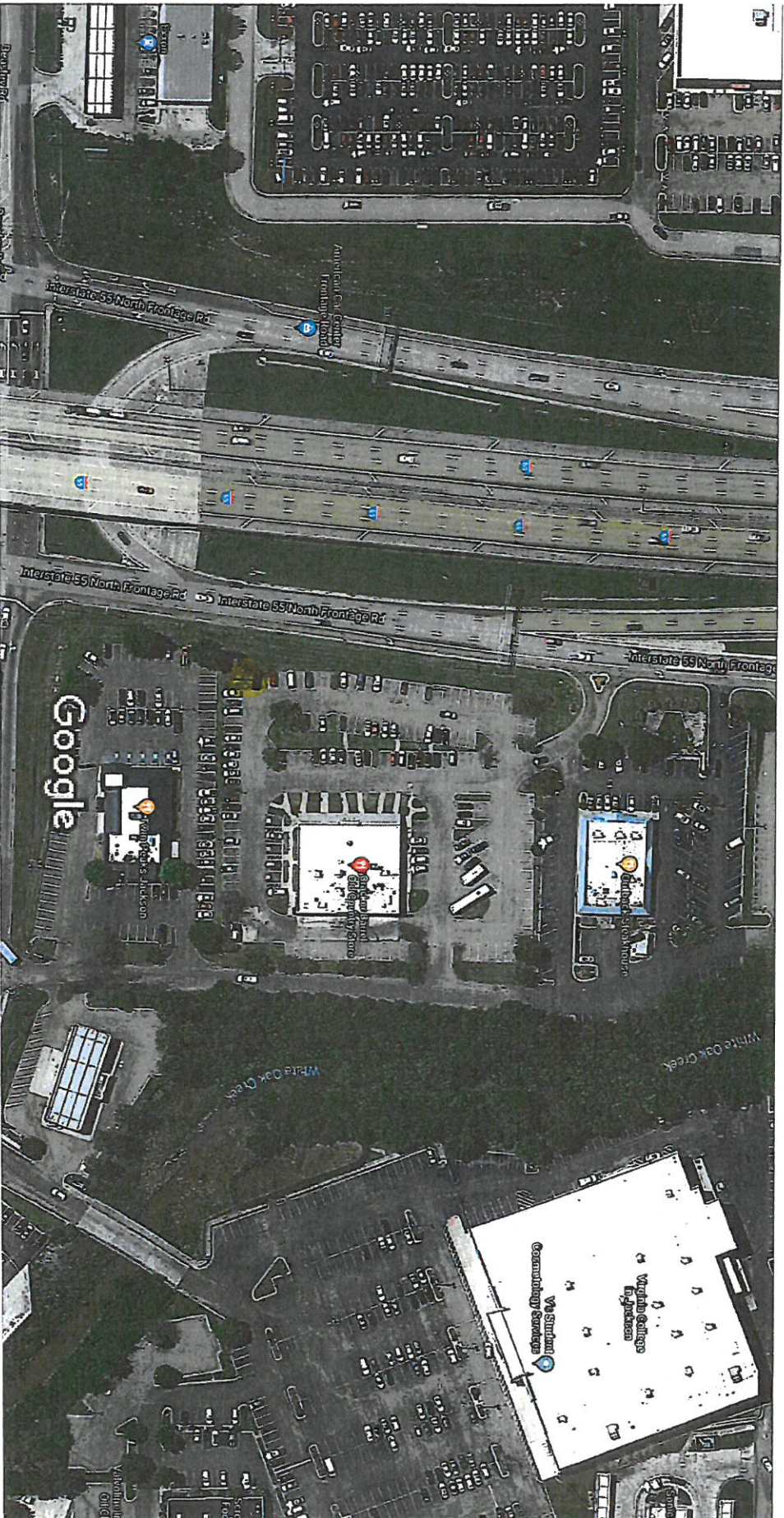

RECEIVED

APR 02 2018

Aerial view: Cracker Barrel Old Country Store

6020 Interstate 55 North Frontage Road

SIGN AND LICENSE DIVISION

Jackson, MS





OFFICE OF THE CITY ATTORNEY  
4/24/18

**ORDER REQUESTING THE CITY COUNCIL REVIEW AND VOTE TO DENY THE SIGN VARIANCE REQUEST FOR CRACKER BARREL OLD COUNTRY STORE TO REFACE THEIR EXISTING NONCONFORMING 240 SQ. FT. GROUND SIGN AT 50 FT. IN HEIGHT WITHIN A C-3 ZONE WHICH ONLY ALLOWS GROUND SIGNS TO BE 200 SQ. FT. IN SIZE AND 35 FT. IN HEIGHT (WARD 7)**

**WHEREAS**, the public health, safety or general welfare of the community may require that variances be granted in specific cases as set forth in City of Jackson Sign Ordinance, Sections 102-26, et seq., of the City of Jackson Code of Ordinances; and

**WHEREAS**, pursuant to Section 102-40, no action by the City Council may be taken concerning a variance from the sign regulations until after a public hearing in relation thereto, at which parties in interest and the general citizenry shall have an opportunity to be heard; and

**WHEREAS**, no variance from the Sign Ordinance shall be passed by the City Council unless and until an application seeking the variance is filed with the City's Signs and License Division, with such application containing, at a minimum, a legal description, location map, plot plan, the exact nature of the requested variance, the grounds upon which it is requested, and/or such other information as may be required by the Signs and License Division manager; and

**WHEREAS**, said variance application shall also demonstrate that:

1. Special conditions and circumstances exist which are peculiar to the land, structure, or building involved and which are not applicable to other lands, structures, or buildings in the same district;
2. The literal interpretation of the provisions of the Sign Ordinance would deprive the applicant of rights commonly enjoyed by other properties in the same district under the provisions of the Sign Ordinance;
3. The special conditions and circumstances do not result from actions of the applicant; and
4. Granting the variance requested will not confer upon the applicant any special privilege that is denied by the Sign Ordinance to other similar lands, structures, or buildings in the same district; and

**WHEREAS**, Cracker Barrel Old Country Store, the applicant herein, has requested a variance from the Sign Ordinance regulations to reface their existing nonconforming 240 sq. ft. ground sign at 50 ft. in height within a C-3 zone which only allows ground signs to be 200 sq. ft. in size and 35 ft. in height.

**IT IS THEREFORE, ORDERED** that Cracker Barrel Old Country Store is hereby *(denied)* a variance from the Sign Ordinance regulations to reface their existing nonconforming 240 sq. ft. ground sign at 50 ft. in height within a C-3 zone which only allows ground signs to be 200 sq. ft. in size and 35 ft. in height, it being determined that the parties in interest and the general citizenry first had their opportunity to be heard and that the applicant *(has not)* met the necessary criteria for the requested variance.

**IT IS FURTHER ORDERED** that the City Council has considered the variance application and denies the variance requested therein based on a finding that no special conditions and circumstances exist which are peculiar to the land, structure, or building involved and which are not applicable to other lands, structures, or buildings in the same district; the literal interpretation of the provision of the Sign Ordinance *(would not)* deprive the applicant of rights commonly enjoyed by other properties in the same district under the provisions of the Sign Ordinance; the special conditions and circumstances do not result from actions of the applicant; and granting the variance requested *(will)* confer upon the applicant any special privilege that is denied by the Sign Ordinance to other similar lands, structures, or buildings in the same district.

Item#

Date:

By: Coleman, Kumar, Lumumba

**CITY COUNCIL AGENDA ITEM 10 POINT DATA SHEET**

04/17/18

DATE

<b>POINTS</b>		<b>COMMENTS</b>								
1.	<b>Brief Description/Purpose</b>	To reface their existing nonconforming 240 sq. ft. ground sign at 50 ft. in height within a C-3 zone which only allows ground signs to be 200 sq. ft. in size and 35 ft. in height.								
2.	<b>Public Policy Initiative</b> 1. Youth & Education 2. Crime Prevention 3. Changes in City Government 4. Neighborhood Enhancement 5. Economic Development 6. Infrastructure and Transportation 7. Quality of Life	N/A								
3.	<b>Who will be affected</b>	N/A								
4.	<b>Benefits</b>	N/A								
5.	<b>Schedule (beginning date)</b>	N/A								
6.	<b>Location:</b> ■ WARD ■ CITYWIDE (yes or no) (area) ■ Project limits if applicable	6020 I-55 N WARD 7								
7.	<b>Action implemented by:</b> ■ City Department <input checked="" type="checkbox"/> ■ Consultant <input type="checkbox"/>	Department of Planning & Development Signs & License Division								
8.	<b>COST</b>	N/A								
9.	<b>Source of Funding</b> ■ General Fund <input type="checkbox"/> ■ Grant <input type="checkbox"/> ■ Bond <input type="checkbox"/> ■ Other <input type="checkbox"/>	N/A								
10.	<b>EBO participation</b>	ABE	_____ %	WAIVER	yes	___	no	___	N/A	<u>X</u>
		AABE	_____ %	WAIVER	yes	___	no	___	N/A	<u>X</u>
		WBE	_____ %	WAIVER	yes	___	no	___	N/A	<u>X</u>
		HBE	_____ %	WAIVER	yes	___	no	___	N/A	<u>X</u>
		NABE	_____ %	WAIVER	yes	___	no	___	N/A	<u>X</u>



Department of Planning and Development



200 South President Street  
Post Office Box 17  
Jackson, Mississippi 39205-0017

## MEMORANDUM

**TO:** Mayor Chokwe Antar Lumumba

**FROM:** Dr. Mukesh Kumar, Director *mk*  
Department of Planning & Development

**DATE:** April 17, 2018

**RE:** Sign Variance

---

Cracker Barrel Old Country Store, located at 6020 I-55 N, is requesting a variance to reface their existing nonconforming 240 sq. ft. ground sign at 50 ft. in height within a C-3 zone which only allows ground signs to be 200 sq. ft. in size and 35 ft. in height.

Office of the City Attorney



455 East Capitol Street  
Post Office Box 2779  
Jackson, Mississippi 39207-2779  
Telephone: (601) 960-1799  
Facsimile: (601) 960-1756

## OFFICE OF THE CITY ATTORNEY

OFFICE OF THE CITY ATTORNEY  
APR 27 2018

This ORDER REQUESTING THE CITY COUNCIL REVIEW AND VOTE TO **DENY** THE SIGN VARIANCE REQUEST FOR CRACKER BARREL OLD COUNTRY STORE TO REFACE THEIR EXISTING NONCONFORMING 240 SQ. FT. GROUND SIGN AT 50 FT. IN HEIGHT WITHIN A C-3 ZONE WHICH ONLY ALLOWS GROUND SIGNS TO BE 200 SQ. FT. IN SIZE AND 35 FT. IN HEIGHT (WARD 7) is legally sufficient for placement in NOVUS Agenda.

Sharon D. Gipson, City Attorney

Dana Sims, Deputy City Attorney

4/27/18

DATE

RECEIVED

APR 02 2018

SIGN AND LICENSE DIVISION

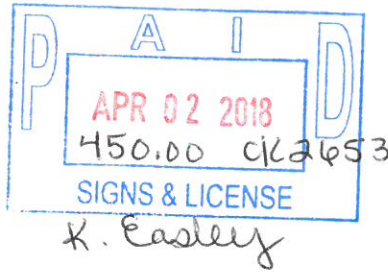

FOR OFFICE USE ONLY

CASE NO.: \_\_\_\_\_

### CITY OF JACKSON, MS

## Application for Sign Variance

I. Subject Property Address: 6020 I-55 NORTH, JACKSON, MS

II. Purpose for requested Sign Variance: (Brief Description)

PLEASE SEE ATTACHED

III. Have you or any other individual been cited for or notified of any ordinance violations related to this property or business? No  
If yes, please give details and dates of violations:

IV. Are there any Restrictive Covenants? No If yes, please attach copies

V. What is the Zoning classification of property? C-3 (GENERAL COMMERCIAL)  
If yes, please attach copies of agency findings and decisions.

### VI. APPLICANT'S INFORMATION:

Name: CRACKER BARREL OLD COUNTRY STORE

Mailing Address: P.O. Box 787

City: LEBANON State: TN Zip: 37088

Contact Phone: 615-443-9373 Fax: 615-443-9895

Email: TINA.BEASLEY@CRACKERBARREL.COM

RECEIVED

APR 02 2018

SIGN AND LICENSE DIVISION

VII. APPLICANT WILL BE REPRESENTED BY:

Name: RICHARD FRANKEL C/O ELROD ENGINEERING  
Mailing Address: 871 SEVEN OAKS BLVD, STE 220  
City: SMYRNA State: TN Zip: 37167  
Contact Phone: 615-512-8220 Fax: 615-890-3580  
Email: rf@elrodllc.com

VIII. CURRENT PROPERTY OWNER(S):

Name: CRACKER BARREL Old Country Store  
Mailing Address: P.O. Box 787  
City: HERSAND State: TN Zip: 37088  
Email: TINA.BEASLEY@CRACKERBARREL.COM

IX. APPLICATION FEE SCHEDULE: \*fees are non-refundable after public hearing

Variance(s) \$450.00

RECEIVED

APR 12 2018

SIGN AND LICENSE DIVISION

DECLARATION:

By signing this application, it is understood and agreed that permission is hereby given the duly authorized representative of the City of Jackson to make an investigation of the need for the sign variance request. It is further understood that the Sign & License Manager and staff may inspect the subject property, make photographs and obtain any verifications and data necessary for preparation of its report to the City Council.

The above information is true and complete to the best of my knowledge.

\_\_\_\_\_ Tina Boastley 3/5/18

WITNESS THE SIGNATURE(S) of the owner(s) of the subject property located at

6020 I 55 N Jackson, Mississippi

On this the 5<sup>th</sup> day of March, 2018.

~~STATE OF MISSISSIPPI~~ State of Tennessee  
~~COUNTY OF HINDS~~ County of Wilson

Personally came and appeared before me, the within named:

\_\_\_\_\_ Tina Boastley

Who signed and delivered the above and foregoing instrument as and for their free act and deed on the day and year therein mentioned, and who acknowledge to me that they are the owner(s) of the subject property as described in this Sign Variance Application.

GIVEN UNDER MY HAND AND OFFICIAL SEAL OF OFFICE, this the 5<sup>th</sup>

Day of March, 2018.

MY COMMISSION EXPIRES:

12/22/21

Charlotta H. Nokes  
NOTARY PUBLIC



RECEIVED

APR 12 2018

City of Jackson, MS  
Application for Sign Variance

SIGN AND LICENSE DIVISION

II. Purpose for requested Sign Variance: (Brief Description)

Cracker Barrel Old Country Store, located at 6020 Interstate 55 North Frontage Road, initially sought to replace, one-for-one, the cabinet of the sign located on the front of the property. The existing 240 square foot cabinet and support structure are 50 feet overall height. The current Jackson codes restricts signs in this district to 200 square feet at 35 feet overall height. To reduce the sign height to the current standards would limit the visibility of the sign and therefore negatively impact the flow of business to the Cracker Barrel store.

Cracker Barrel is willing to compromise with the city by reducing the cabinet size to 200 square feet, but respectfully requests the overall height of the sign remain at 50 feet.

*Joe Beasley*  
Identity Coordinator  
Cracker Barrel Old Country Store, Inc.

STATE OF TENNESSEE  
COUNTY OF Wilson

On this day personally appeared before me Charlotte Nokes, to me known to be the individual who executed the within and foregoing instrument, and acknowledged that she signed the same as her free and voluntary act and deed, for the uses and purposes therein mentioned.

Given under my hand and seal of office this 12<sup>th</sup> day of April, 2018.

Printed Name: Charlotte H. Nokes  
My Commission Expires 12/22/2021



Department of Planning and Development



200 South President Street  
Post Office Box 17  
Jackson, Mississippi 39205-0017

April 18, 2018

Elrod Engineering  
Richard Frankel  
871 Seven Oaks Blvd, Suite 220  
Smyrna, TN 37167

Re: Cracker Barrel Old Country Store Sign Variance Application

Dear Mr. Frankel:

Just wanted to inform you that our office is currently working on the sign variance request that you submitted on behalf of Cracker Barrel Old Country Store located at 6020 I-55 N.

During the review and processing time of your sign variance request we are required to inform the applicant or the applicant's representative of the staff's recommendation for this sign variance request. Your application and supporting documents indicate that Cracker Barrel Old Country Store is requesting to reface their existing nonconforming 240 sq. ft. ground sign at 50 ft. in height within a C-3 zone which only allows ground signs to be 200 sq. ft. in size and 35 ft. in height.

The staff's recommendation is for approval of your sign variance request.

Sincerely,

A handwritten signature in black ink that reads 'Terry Coleman'. The signature is written in a cursive, flowing style.

Terry Coleman, Manager  
Signs & License Division



RECEIVED

APR 02 2018

APPLICATION FOR SIGN PERMIT
CITY OF JACKSON
DEPARTMENT OF PLANNING AND DEVELOPMENT
SIGN AND LICENSE DIVISION
200 S. PRESIDENT STREET-JACKSON, MS 39201
601-960-1154

SIGN AND LICENSE DIVISION

DATE RECEIVED IN OFFICE:

Form with sections: CONTRACTOR/ERECTOR, LOCATION/ADDRESS OF SIGN, GROUND-MOUNTED, BUILDING-MOUNTED, TYPE OF LIGHTING, WORDING ON SIGN(S), ZONING CLASS, and checkboxes for Temporary Banner, Plot Drawings, Sign Drawings.

I hereby certify that I have read this application and that all information contained herein is true and correct; that I agree to comply with all City Ordinances, Codes, and State Laws regulating sign construction; that I am the owner or authorized to act as the owner's agent for the herein described work.

Applicant's Signature

Date 03-28-2018

Sign and License Division Manager



## WARRANTY DEED

FOR AND IN CONSIDERATION, of the sum of Ten Dollars (\$10.00), cash in hand paid, and other good and valuable considerations, the receipt and sufficiency all of which is hereby acknowledged, the undersigned, Mattiace Properties, Inc., a Mississippi corporation, Grantor, does hereby sell, convey and warrant unto Cracker Barrel Old Country Store, Inc., a Tennessee corporation, Grantee, the following land and property situated in the City of Jackson, Hinds County, State of Mississippi, to-wit:

Part of the Southeast 1/4 of the Southeast 1/4 of Section 1, Township 6 North, Range 1 East, Jackson, Hinds County, Mississippi and described as follows:

Begin at a point that is 428.2 feet North of and 1,120.63 feet West of the Southeast Corner of said Section 1, said Point of Beginning is on the present Easterly Right of Way Line of I-55; from said Point of Beginning run thence along said Right of Way line the following: North 8° 00' East, a distance of 242.67 feet; thence along a curve to the left having a radius of 4,609.66 feet a distance of 123.53 feet said curve has a chord of North 7° 14' 24" East, a distance of 123.53 feet; thence South 67° 33' 25" East, a distance of 50.95 feet; thence leaving said right of way line run South 1° 49' West, a distance of 13.25 feet; thence South 88° 11' East, a distance of 303.85 feet; thence South 4° 00' West, a distance of 350.98 feet; thence South 1° 06' West, a distance of 183.7 feet to the Northerly Right of Way Line of Adkins Boulevard; thence North 77° 38' West, along said Right of Way Line a distance of 50.98 feet; thence North 1° 06' East, a distance of 200.3 feet; thence North 89° 38' West, a distance of 325.76 feet to the Point of Beginning, containing 131,172.84 square feet or 3.0113 acres.

## LESS AND EXCEPT:

Begin at a point that is 428.2 feet north of and 1120.63 feet west of the Southeast corner of said Section 1, said Point of Beginning is on the present easterly right of way line of I-55; from said Point of Beginning run thence North 8° 00' East, along said right of way line a distance of 30.0 feet; thence South 89° 38' East, a distance of 50.0 feet; thence South 8° 00' West, a distance of 30.0 feet; thence North 89° 38' West, a distance of 50.0 feet to the Point of Beginning, containing 1486.7 square feet or 0.03 acres, more or less.

This conveyance is made subject to and there is excepted from the warranty hereof the following:

1. Any prior reservation or conveyance, together with release of damages, of minerals of every kind and character, including, but not limited to, oil, gas, sand, and gravel in, on, and under subject property.
2. Reservation of Perpetual Easement for ingress and egress over 50' X 183.7' strip as described in instrument recorded in Book 3694 at Page 22 in the office of the Chancery Clerk of Hinds County at Jackson, Mississippi.
3. 10' Easement for Utilities along the East side of subject parcel et al for the benefit of owner of lands North of and adjacent to subject parcel as recorded in Book 2080 at Page 370 and, also, Book 2080 at Page 437 in the office of the aforesaid Chancery Clerk.
4. Temporary Easement to the State Highway Commission of Mississippi dated October 27, 1982, for a term of 10 years as

recorded in Book 2870 at Page 353 in the office of the aforesaid Chancery Clerk.

5. Release of Damages to the State Highway Commission of Mississippi as recorded in Book 2870 at Page 355 and Book 2870 at Page 1171 in the office of the aforesaid Chancery Clerk.

6. Release of Damages etc. to the State Highway Commission of Mississippi as recorded in Book 1030 at Page 516, Book 1046 at Page 479, Book 2870 at Page 1171 and Book 2870 at Page 1173 in the office of the aforesaid Chancery Clerk.

Ad valorem taxes for the current year have been prorated between Grantors and Grantee on an estimated basis. When said taxes are actually determined, if the proration as of this date is incorrect, then Grantors agree to pay Grantee any additional amounts due, and Grantee agrees to pay Grantors any amounts overpaid. Grantee assumes and agrees to pay ad valorem taxes for all subsequent years.

WITNESS OUR SIGNATURE, this the 25<sup>th</sup> day of October, 1991.

RECEIVED

APR 02 2018

MATTIACE PROPERTIES, INC.,  
a Mississippi corporation

BY: [Signature]  
T. Andrew Mattiace, President

SIGN AND LICENSE DIVISION

ADDRESS OF GRANTOR:

Mattiace Properties, Inc.  
1818 Crane Ridge Drive  
Jackson, Mississippi 39216  
ATTENTION: T. Andrew Mattiace  
BUSINESS PHONE: (601) 982-1820  
RESIDENCE PHONE: None

ADDRESS OF GRANTEE:

Cracker Barrel Old Country  
Store, Inc.  
P. O. Box 787  
Hartman Drive  
Lebanon, Tennessee 37088-0787  
ATTENTION: V. P. Development  
BUSINESS PHONE: (615) 444-5533  
RESIDENCE PHONE: None

STATE OF MISSISSIPPI

COUNTY OF HINDS

Personally appeared before me, the undersigned authority in and for the said county and state, on this 25<sup>th</sup> day of October, 1991, within my jurisdiction, the within named T. Andrew Mattiace, duly identified before me, who acknowledged that he is President of Mattiace Properties, Inc., a Mississippi corporation, and that for and on behalf of said corporation, and as its act and deed, he executed the above and foregoing instrument, after first having been duly authorized by said corporation so to do.

[Signature]  
NOTARY PUBLIC

My Commission Expires:

My Commission Expires April 23, 1993

(Affix official seal)



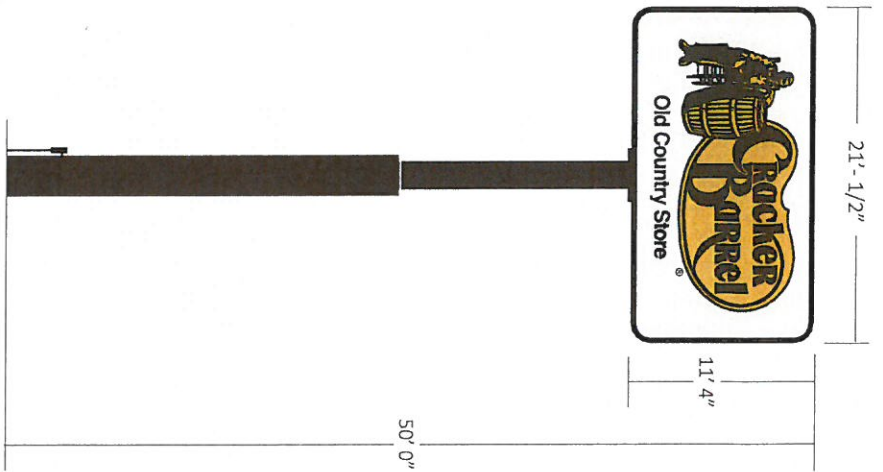

240sf @ 50'-0"  
Existing Flex Face Sign

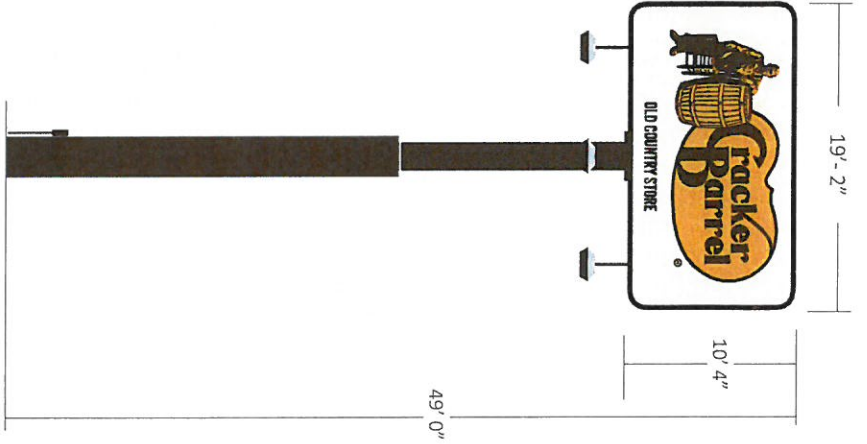

200sf @ 50'-0"  
Porcelain Face  
Variance Proposed

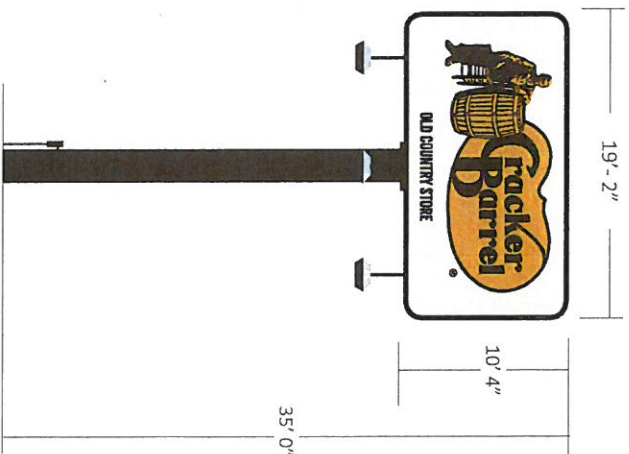

200sf @ 35'-0"  
Porcelain Face  
Current Sign Codes

**RECEIVED**

APR 02 2018

Store #CB139  
6020 I-55 North  
Jackson, MS

SIGN AND LICENSE DIVISION

	SCALE:	NTS	NO:	200sf PF X3624
	DATE:	3/2/2018	REVISION:	REVISION DATE:

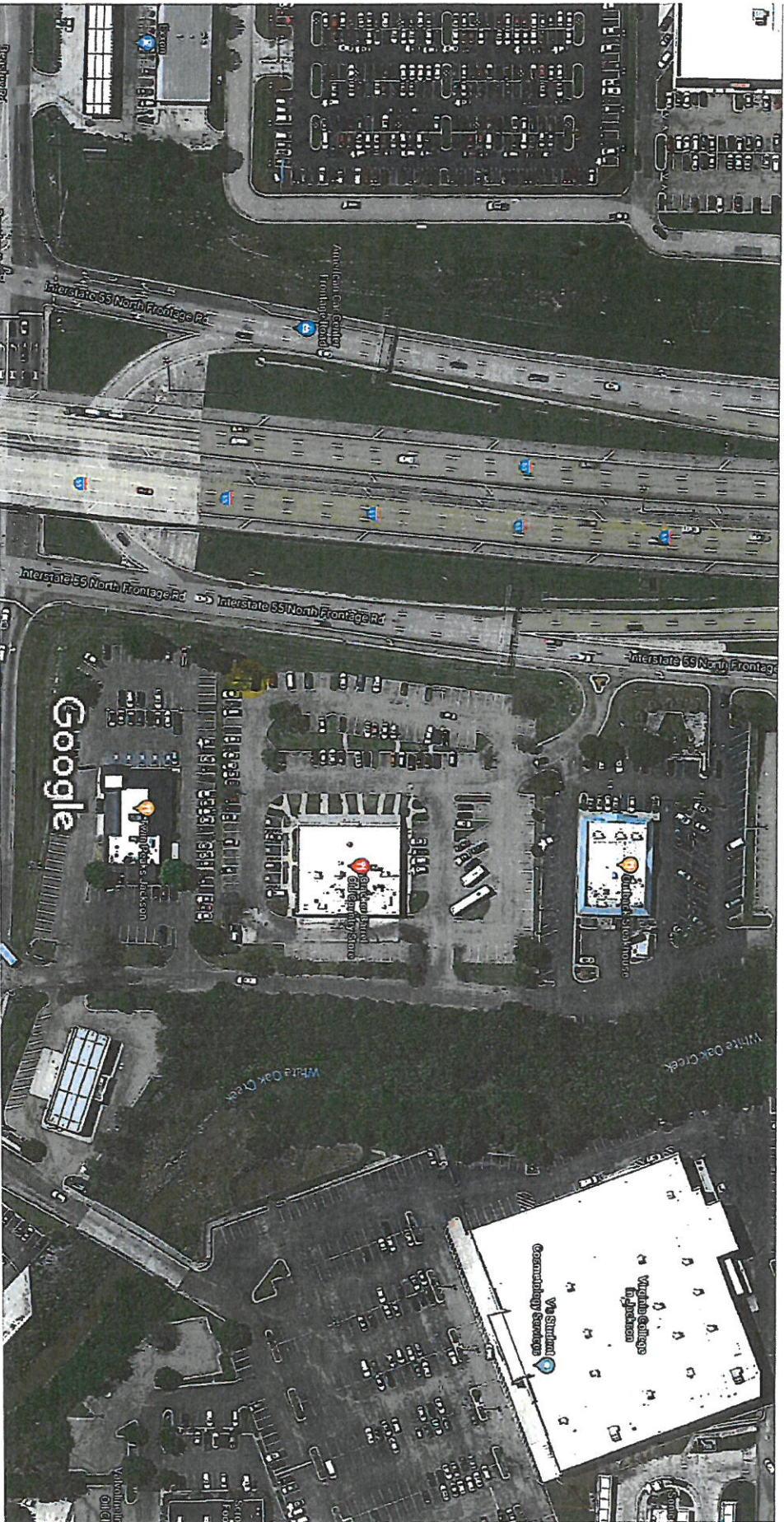

RECEIVED

APR 02 2018

Aerial view: Cracker Barrel Old Country Store

6020 Interstate 55 North Frontage Road

SIGN AND LICENSE DIVISION

Jackson, MS



**LEGAL DESCRIPTIONS**

Part of the Southwest 1/4 of Section 29, T. 2 S., R. 1 W., Jackson Township, Michigan County, Michigan, described as follows: ...

Part of the Southwest 1/4 of Section 29, T. 2 S., R. 1 W., Jackson Township, Michigan County, Michigan, described as follows: ...

**INGRESS/EGRESS DESCRIPTION #1**

Part of the Southwest 1/4 of Section 29, T. 2 S., R. 1 W., Jackson Township, Michigan County, Michigan, described as follows: ...

**INGRESS/EGRESS DESCRIPTION #2**

Part of the Southwest 1/4 of Section 29, T. 2 S., R. 1 W., Jackson Township, Michigan County, Michigan, described as follows: ...

**RECEIVED**

APR 02 2018

**SIGN AND LICENSE DIVISION**

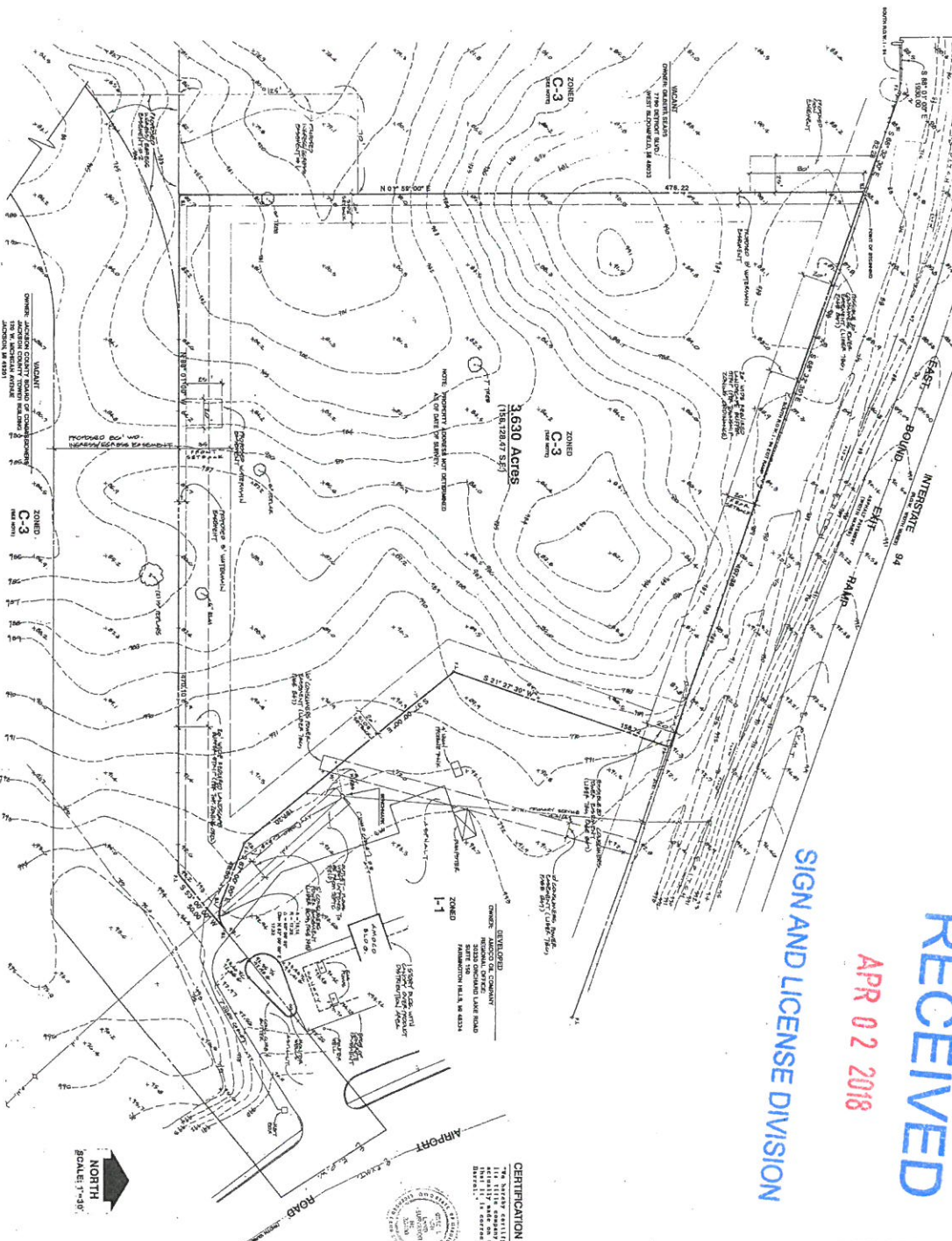

**CERTIFICATION**

The survey was made in accordance with the laws of the State of Michigan, and the surveyor is duly licensed and qualified to perform the same. The survey was made on the 29th day of March, 2018, and the same is hereby certified to be correct and true to the best of my knowledge and belief.

**DIETRICH, BAILEY AND ASSOCIATES, P.C.**  
 10000 E. 14th Street, Jackson, MI 49201  
 Phone: (517) 788-4881  
 Fax: (517) 788-4882

**CLIENT:**  
 CRACKER BARREL  
 OLD COUNTRY STORE, INC.  
 HARTSMANN DRIVE, P.O. BOX 187  
 LEBANON, TN 37087

NO.	DATE	ISSUED FOR	BY

**BOUNDARY & TOPOGRAPHIC SURVEY**  
**CRACKER BARREL OLD COUNTRY STORE, INC.**  
 PART OF THE S.W. QUARTER SECTION 29, T. 2 S., R. 1 W.,  
 BLACKMAN TOWNSHIP, JACKSON COUNTY, MICHIGAN.

**DBA DIETRICH, BAILEY AND ASSOCIATES, P.C.**  
 10000 E. 14th Street, Jackson, Michigan 49201  
 Phone: (517) 788-4881  
 Fax: (517) 788-4882  
 Engineering Planning Surveying Landscape Architecture

**CLIENT:**  
 CRACKER BARREL  
 OLD COUNTRY STORE, INC.  
 HARTSMANN DRIVE, P.O. BOX 187  
 LEBANON, TN 37087

OFFICE OF THE CITY ATTORNEY  
*Alton*

**ORDER AUTHORIZING THE MAYOR TO EXECUTE A CONTRACT BETWEEN THE CITY OF JACKSON AND SMITH, ALTON, ACA DEMOLITION & PROJECT GROUP,LLC 120 HILLCROFT PLACE, JACKSON , MISSISSIPPI 39211 FOR THE DEMOLITION AND REMOVAL OF STRUCTURE(S), FOUNDATION, STEPS, DRIVEWAY, THE CUTTING OF GRASS AND WEEDS AND REMOVAL OF TRASH AND DEBRIS AND REMEDYING OF CONDITIONS ON PRIVATE PROPERTY WHICH CONSTITUTE A MENACE TO PUBLIC HEALTH, SAFETY AND WELFARE ACCORDING TO THE MISSISSIPPI CODE ANNOTATED SECTION 21-19-11. CASE # 2012-2218 – 3758 NORTHVIEW DRIVE – \$3,323.00 – WARD 7**

**WHEREAS**, on September 24, 2013 the City Council adopted the resolutions, declaring certain parcels of real property in the City of Jackson to be a menace to public health, safety and welfare pursuant to Section 21-19-11 of the Mississippi Code pursuant to Administrative Hearing held on August 6,2013 for the following case: *Case# 2012-2218 located in Ward 7* and

**WHEREAS**, the Jackson Police Department’s Community Improvement Division has a system in which vendors performing services related to the remedying of conditions on property adjudicated to be a menace to public health, safety, and welfare are rotated; and

**WHEREAS**, SMITH, ALTON, ACA DEMOLITION & PROJECT GROUP,LLC appeared next on the rotation list and has agreed to demolish the structure, cut grass and weeds, and remedy the conditions for case 2012-2218 located at *3758 Northview Drive*; and

**WHEREAS**, the project accepted by SMITH, ALTON, ACA DEMOLITION & PROJECT GROUP,LLC is for the demolishing and cleaning of the aforementioned parcel for the amount of \$3,323.00;

**IT IS, THEREFORE, ORDERED**, that the Mayor be authorized to execute a contract with SMITH, ALTON, ACA DEMOLITION & PROJECT GROUP,LLC, providing the demolition and removal of structure(s), foundation, steps, driveway and the cutting of grass and weeds and removal of tires, trash and debris and remedying of conditions on the stated property.

**IT IS, THEREFORE, ORDERED**, that the payment for the said contract be made from the Community Improvement Unit’s Budget.

Agenda Item#

Agenda Date

**CITY COUNCIL AGENDA ITEM 10 POINT DATA SHEET**

**04/19/2018**  
**DATE**

<b>POINTS</b>		<b>COMMENTS</b>																																													
1.	<b>Brief Description/Purpose</b>	This item provides for the demolition and removal of structures, foundation, steps, driveway and cutting of grass and weeds and removing of trash and debris for cases adjudicated a menace by the City Council. The Order is asking that the Mayor be authorized to execute a contract for the completion of the work to improve public health, safety and welfare.																																													
2.	<b>Public Policy Initiative</b> <ol style="list-style-type: none"> <li>1. Youth &amp; Education</li> <li>2. Crime Prevention</li> <li>3. Changes in City Government</li> <li>4. Neighborhood Enhancement</li> <li>5. Economic Development</li> <li>6. Infrastructure and Transportation</li> <li>7. Quality of Life</li> </ol>	<ol style="list-style-type: none"> <li>1. Neighborhood Enhancement</li> <li>2. Crime Prevention</li> <li>7. Quality of Life</li> </ol>																																													
3.	<b>Who will be affected</b>	All City of Jackson residents																																													
4.	<b>Benefits</b>	The demolition of structures and cleaning of those properties will improve the conditions of communities and will also remove and/or deter threats to improve the public health, safety, and welfare of surrounding residents and communities.																																													
5.	<b>Schedule (beginning date)</b>	To be determined pending execution of contracts.																																													
6.	<b>Location:</b> <ul style="list-style-type: none"> <li>▪ WARD</li> <li>▪ CITYWIDE (yes or no) (area)</li> <li>▪ Project limits if applicable</li> </ul>	WARD 7																																													
7.	<b>Action implemented by:</b> <ul style="list-style-type: none"> <li>▪ City Department <input type="checkbox"/></li> <li>▪ Consultant <input type="checkbox"/></li> </ul>	JACKSON POLICE DEPARTMENT COMMUNITY IMPROVEMENT UNIT																																													
8.	<b>COST</b>	\$3,323.00																																													
9.	<b>Source of Funding</b> <ul style="list-style-type: none"> <li>▪ General Fund <input type="checkbox"/></li> <li>▪ Grant <input type="checkbox"/></li> <li>▪ Bond <input type="checkbox"/></li> <li>▪ Other <input type="checkbox"/></li> </ul>	GENERAL FUNDS (001-442.71-6485)																																													
10.	<b>EBO participation</b>	<table style="width: 100%; border: none;"> <tr> <td>ABE</td> <td>_____ %</td> <td>WAIVER</td> <td>yes</td> <td>___</td> <td>no</td> <td>___</td> <td>N/A</td> <td>___</td> </tr> <tr> <td>AABE</td> <td>_____ %</td> <td>WAIVER</td> <td>yes</td> <td>___</td> <td>no</td> <td>___</td> <td>N/A</td> <td>___</td> </tr> <tr> <td>WBE</td> <td>_____ %</td> <td>WAIVER</td> <td>yes</td> <td>___</td> <td>no</td> <td>___</td> <td>N/A</td> <td>___</td> </tr> <tr> <td>HBE</td> <td>_____ %</td> <td>WAIVER</td> <td>yes</td> <td>___</td> <td>no</td> <td>___</td> <td>N/A</td> <td>___</td> </tr> <tr> <td>NABE</td> <td>_____ %</td> <td>WAIVER</td> <td>yes</td> <td>___</td> <td>no</td> <td>___</td> <td>N/A</td> <td>___</td> </tr> </table>	ABE	_____ %	WAIVER	yes	___	no	___	N/A	___	AABE	_____ %	WAIVER	yes	___	no	___	N/A	___	WBE	_____ %	WAIVER	yes	___	no	___	N/A	___	HBE	_____ %	WAIVER	yes	___	no	___	N/A	___	NABE	_____ %	WAIVER	yes	___	no	___	N/A	___
ABE	_____ %	WAIVER	yes	___	no	___	N/A	___																																							
AABE	_____ %	WAIVER	yes	___	no	___	N/A	___																																							
WBE	_____ %	WAIVER	yes	___	no	___	N/A	___																																							
HBE	_____ %	WAIVER	yes	___	no	___	N/A	___																																							
NABE	_____ %	WAIVER	yes	___	no	___	N/A	___																																							



Jackson Police Department



327 East Pascagoula Street  
Post Office Box 17  
Jackson, Mississippi 39205-0017

## ***Memorandum***

To: Mayor Chokwe A. Lumumba

From: Anthony L. Moore *Alm 5/1/18*  
Chief of Police

Date: May 1, 2018

Ref: Agenda Item

---

The attached agenda item is an Order requesting that the Mayor execute a contract with ALTON SMITH, ACA DEMOLITION & PROJECT GROUP, LLC, for the demolition and removal of structure(s), foundation, steps, driveway, cutting of grass and weeds, and removal of trash and debris for certain parcels of real property in the City of Jackson declared to be a menace to public health, safety and welfare pursuant to Section 21-19-11 of Mississippi Code.

Therefore, we respectfully request that you authorize the execution of contracts from project select and awarded to the said contractor for the following case # 2012-2218.

Thank you for your prompt consideration in this matter.

Jackson Police Department  
Community Improvement Unit



327 East Pascagoula Street  
Post Office Box 17  
Jackson, Mississippi 39205-0017

## MEMORANDUM

TO: Anthony L Moore, Chief of Police *Am 5/1/18*

VIA: James Davis, Assistant Chief

Sandra Stasher, Deputy Chief *SS 4/30/18*  
Administration

Jaye Coleman, Commander *JC 4/30/18*  
Administration

FROM: Henry Davis, Supervisor *HD 4/25/18*  
Community Improvement Unit

DATE: April 19, 2018

Re: Agenda Item

The attached agenda item is an Order requesting that the Mayor execute a contract with ALTON SMITH, ACA DEMOLITION & PROJECT GROUP, LLC , for the demolition and removal of structure(s), foundation, steps, driveway, cutting of grass and weeds, and removal of trash and debris for certain parcels of real property in the City of Jackson declared to be a menace to public health, safety and welfare pursuant to section 21-19-11 of Mississippi Code. Therefore, we request that you authorize the execution of contracts from project select and awarded to the said contractor for the following case: 2012-2218

Thank you for your consideration.

RECEIVED

APR 25 2018  
*5-1 sent to A/C*  
Deputy Chief of Support Services / JPU

Office of the City Attorney

455 East Capitol Street  
Post Office Box 2779  
Jackson, Mississippi 39207-2779  
Telephone: (601) 960-1799  
Facsimile: (601) 960-1756

5/19/18

## OFFICE OF THE CITY ATTORNEY

OFFICE OF THE CITY ATTORNEY  
5/15/18

This ORDER AUTHORIZING THE MAYOR TO EXECUTE A CONTRACT BETWEEN THE CITY OF JACKSON AND SMITH, ALTON, ACA DEMOLITION & PROJECT GROUP, LLC 120 HILLCROFT PLACE, JACKSON, MISSISSIPPI 39211 FOR THE DEMOLITION AND REMOVAL OF STRUCTURE(S), FOUNDATION, STEPS, DRIVEWAY, THE CUTTING OF GRASS AND WEEDS AND REMOVAL OF TRASH AND DEBRIS AND REMEDYING OF CONDITIONS ON PRIVATE PROPERTY WHICH CONSTITUTE A MENACE TO PUBLIC HEALTH, SAFETY AND WELFARE ACCORDING TO THE MISSISSIPPI CODE ANNOTATED SECTION 21-19-11. CASE # 2012-2218 - 3758 NORTHVIEW DRIVE - \$3,323.00 - WARD 7 is legally sufficient for placement in NOVUS Agenda.



Sharon D. Gipson, City Attorney

Carrie Johnson, Deputy City Attorney

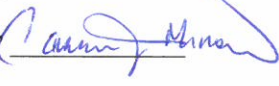

5/15/18

DATE

**ORDINANCE OF THE CITY COUNCIL OF JACKSON, MISSISSIPPI  
RENAMING LAVERNET ROAD (FROM MARTIN LUTHER KING, JR, DRIVE  
TO END) TO CHARLES EVERS DRIVE**

**WHEREAS, Mr. Charles Evers has served the community in many capacities in the City of Jackson and the State of Mississippi; and,**

**WHEREAS, Mr. Charles Evers is currently the head of a local radio station in the City of Jackson known as WMPR; and,**

**WHEREAS, Mr. Charles Evers has fearlessly contributed to the enhancement of the quality of life for the poor and disenfranchised citizens of the City of Jackson and the State of Mississippi; and**

**WHEREAS, the designation of the street will continue the cultural recognition of icons of the civil rights movement and freedom fighters who have walked among us.**

**THEREFORE, BE IT ORDAINED, that the City Council of Jackson, Mississippi hereby renames Lavernet Road (from Martin Luther King, Jr. Drive to End) to Charles Evers Drive.**

**SO ORDAINED, this the \_\_\_\_\_ day of June, 2018.**

**Agenda Item No. 5  
Agenda Date: June 5, 2018  
By: STOKES**

**ORDINANCE OF THE CITY COUNCIL OF JACKSON, MISSISSIPPI  
RENAMING NORTH STREET (FROM MISSISSIPPI STREET TO AMITE STREET)  
TO MYRLIE EVERS DRIVE**

**WHEREAS, Mrs. Myrlie Evers is one of the most recognizable Mississippians of the twenty-first century and has contributed greatly to the civil rights legacy of the City of Jackson; and,**

**WHEREAS, Mrs. Myrlie Evers was married to the late Mr. Medgar Evers, and they were blessed with three children; and,**

**WHEREAS, Mrs. Myrlie Evers has carried on the blood-stained banner of truth and justice left by her husband, Mr. Medgar Evers, as he was assassinated in the driveway of their home in Jackson, Mississippi; and**

**WHEREAS, the designation of the street renaming will enhance the historic nature of the area surrounding the two new museums in the City of Jackson.**

**THEREFORE, BE IT ORDAINED, that the City Council of Jackson, Mississippi hereby renames North Street (from Mississippi Street to Amite Street) to Myrlie Evers Drive.**

**SO ORDAINED, this the \_\_\_\_\_ day of June, 2018.**

**Agenda Item No. 6  
Agenda Date: June 5, 2018  
By: STOKES**

**ORDER REVISING THE FY2017-18 BUDGET TO INCREASE THE CITY CLERK'S VOTER ROLL BUDGET IN THE AMOUNT OF \$500,000.00 FOR ELECTION EXPENSES RELATED TO THE JACKSON PUBLIC SCHOOL'S BOND REFERENDUM.**

**WHEREAS**, the City Clerk's Office will be engaged in the process of overseeing a Special election on August 7, 2018 for the Jackson Public Schools bond referendum; and

**WHEREAS**, the City Clerk's Office does not have an amount in their budget to cover the expenses associated with the overseeing of the JPS elections; and

**WHEREAS**, a budget revision from the General Fund balance will provide funds to increase the City Clerk's budget by \$500,000.00; and

**WHEREAS**, the Jackson Public School district will reimburse the City of Jackson in the amount of \$500,000 incurred during this Special Election; and

**WHEREAS**, the reimbursement to the City of Jackson will be used to replenish the General Fund account #001-5899; and

**WHEREAS**, FY2017-18 budget will be revised as follows:

<b>Account Number</b>	<b>From Account</b>	<b>To Account</b>
001-5899	\$500,000.00	
001-402-20-6419		\$300,000.00
001-402-20-6431		\$200,000.00

**IT IS, THEREFORE ORDERED** that the City Clerk's FY2017-18 budget be increased by the amount of \$500,000.00 expenses related to the Jackson Public Schools bond referendum.

Item #9  
Date: 06/05/18  
By: Blaine, Lumumba

**10-POINT DATA SHEET for CITY COUNCIL AGENDA ITEM    DATE: MAY 31, 2018**

<b>P O I N T S</b>		<b>C O M M E N T S</b>																																													
1.	<b>Brief Description</b>	<b>ORDER REVISING THE FY2017-18 BUDGET TO INCREASE THE CITY CLERK'S VOTER ROLL BUDGET IN THE AMOUNT OF \$500,000.00 FOR ELECTION EXPENSES RELATED TO THE JACKSON PUBLIC SCHOOL'S BOND REFERENDUM.</b>																																													
2.	<b>Purpose</b>	Infrastructure improvement within Jackson Public Schools																																													
3.	<b>Who will be affected</b>	Citizens of Jackson and Jackson Public School District																																													
4.	<b>Benefits</b>	Jackson Public Schools will be in compliance with the external audit																																													
5.	<b>Schedule (beginning date)</b>	August 7, 2018																																													
6.	<b>Location:</b> <ul style="list-style-type: none"> <li>▪ <b>WARD</b></li> <li>▪ <b>CITYWIDE (yes or no) (area)</b></li> <li>▪ <b>Project limits if applicable</b></li> </ul>	Citywide																																													
7.	<b>Action implemented by:</b> <ul style="list-style-type: none"> <li>▪ <b>City Department</b>    <input checked="" type="checkbox"/></li> <li>▪ <b>Consultant</b>            <input type="checkbox"/></li> </ul>	City Clerk's Office																																													
8.	<b>COST</b>	\$500,000 to be reimbursed by Jackson Public Schools before September 30, 2018.																																													
9.	<b>Source of Funding</b> <ul style="list-style-type: none"> <li>▪ <b>General Fund</b>        <input type="checkbox"/></li> <li>▪ <b>Grant</b>                    <input type="checkbox"/></li> <li>▪ <b>Bond</b>                    <input type="checkbox"/></li> <li>▪ <b>Other</b>                    <input type="checkbox"/></li> </ul>	General Fund #001-5899																																													
10.	<b>EBO participation</b>	<table style="width: 100%; border-collapse: collapse;"> <tr> <td style="width: 15%;">ABE</td> <td style="width: 15%;">_____%</td> <td style="width: 15%;">WAIVER</td> <td style="width: 5%;">yes</td> <td style="width: 5%;">___</td> <td style="width: 5%;">no</td> <td style="width: 5%;">___</td> <td style="width: 10%;">N/A</td> <td style="width: 5%;">_x_</td> </tr> <tr> <td>AABE</td> <td>_____%</td> <td>WAIVER</td> <td>yes</td> <td>___</td> <td>no</td> <td>___</td> <td>N/A</td> <td>_x_</td> </tr> <tr> <td>WBE</td> <td>_____%</td> <td>WAIVER</td> <td>yes</td> <td>___</td> <td>no</td> <td>___</td> <td>N/A</td> <td>_x_</td> </tr> <tr> <td>HBE</td> <td>_____%</td> <td>WAIVER</td> <td>yes</td> <td>___</td> <td>no</td> <td>___</td> <td>N/A</td> <td>_x_</td> </tr> <tr> <td>NABE</td> <td>_____%</td> <td>WAIVER</td> <td>yes</td> <td>___</td> <td>no</td> <td>___</td> <td>N/A</td> <td>_x_</td> </tr> </table>	ABE	_____%	WAIVER	yes	___	no	___	N/A	_x_	AABE	_____%	WAIVER	yes	___	no	___	N/A	_x_	WBE	_____%	WAIVER	yes	___	no	___	N/A	_x_	HBE	_____%	WAIVER	yes	___	no	___	N/A	_x_	NABE	_____%	WAIVER	yes	___	no	___	N/A	_x_
ABE	_____%	WAIVER	yes	___	no	___	N/A	_x_																																							
AABE	_____%	WAIVER	yes	___	no	___	N/A	_x_																																							
WBE	_____%	WAIVER	yes	___	no	___	N/A	_x_																																							
HBE	_____%	WAIVER	yes	___	no	___	N/A	_x_																																							
NABE	_____%	WAIVER	yes	___	no	___	N/A	_x_																																							

**ORDER CLARIFYING PREVIOUS ORDER AUTHORIZING THE MAYOR TO EXECUTE AN AGREEMENT WITH COGENT COMMUNICATIONS TO MOVE THE CITY OF JACKSON FROM 1 G OF BROADBAND ACCESS TO 10GIG BROADBAND ACCESS**

OFFICE OF THE CITY CLERK  
2018  
5/15/18  
CITY OF JACKSON, MISSISSIPPI

**WHEREAS**, the governing authorities for the City of Jackson previously approved an Order Authorizing Mayor to Execute an Agreement with Cogent Communications to move the City of Jackson form 1g of broadband access to 10gig broadband access; and

**WHEREAS**, shortly thereafter Cogent subcontracted with LiteCloud to provide the same services to the City of Jackson; and

**WHEREAS**, LiteCloud is a regional ISP that is a wholesale consumer of Cogent bandwidth; and

**IT IS, THEREFORE, ORDERED** that the Mayor is authorized to execute the agreement with LiteCloud in lieu of Cogent for a 36 month period; and

**IT IS, FURTHER, ORDERED** that the cost of this service shall include a one-time installation fee of \$1,000 and a monthly rate of \$3,550.

Item #10  
Date: 6/5/18  
By: Blaine, Lumumba



CITY COUNCIL AGENDA ITEM 10 POINT DATA SHEET

05-15-18  
DATE

POINTS		COMMENTS																																																							
1.	Brief Description	This item authorizes to clarify a previously agreed upon order.																																																							
2.	Public Policy Initiative Youth & Education Crime Prevention Changes in City Government Neighborhood Enhancement Economic Development Infrastructure and Transportation Quality of Life	Quality of Life																																																							
3.	Who will be affected	City of Jackson residents																																																							
4.	Benefits	Allows the City to multiply its broadband access by 10 without a change in pricing.																																																							
5.	Schedule (beginning date)	Upon Council Approval																																																							
6.	Location: WARD  CITYWIDE (yes or no) (area)  Project limits if applicable	Citywide																																																							
7.	Action implemented by: City Department <input type="checkbox"/>  Consultant <input type="checkbox"/>	CAO Office																																																							
8.	COST	\$3,550 per month, One time Installation Fee of \$1,000.																																																							
9.	Source of Funding General Fund <input type="checkbox"/> Grant <input type="checkbox"/> Bond <input type="checkbox"/> Other <input type="checkbox"/>	004904006454																																																							
10.	EBO participation	<table border="0"> <tr> <td>ABE</td> <td>100</td> <td>%</td> <td>WAIVER</td> <td>___</td> <td>Yes</td> <td>___</td> <td>No</td> <td>___</td> <td>N/A</td> <td>___</td> </tr> <tr> <td>AABE</td> <td>___</td> <td>%</td> <td>WAIVER</td> <td>___</td> <td>Yes</td> <td>___</td> <td>No</td> <td>___</td> <td>N/A</td> <td>___</td> </tr> <tr> <td>WBE</td> <td>___</td> <td>%</td> <td>WAIVER</td> <td>___</td> <td>Yes</td> <td>___</td> <td>No</td> <td>___</td> <td>N/A</td> <td>___</td> </tr> <tr> <td>HBE</td> <td>___</td> <td>%</td> <td>WAIVER</td> <td>___</td> <td>Yes</td> <td>___</td> <td>No</td> <td>___</td> <td>N/A</td> <td>___</td> </tr> <tr> <td>NABE</td> <td>___</td> <td>%</td> <td>WAIVER</td> <td>___</td> <td>Yes</td> <td>___</td> <td>No</td> <td>___</td> <td>N/A</td> <td>___</td> </tr> </table>	ABE	100	%	WAIVER	___	Yes	___	No	___	N/A	___	AABE	___	%	WAIVER	___	Yes	___	No	___	N/A	___	WBE	___	%	WAIVER	___	Yes	___	No	___	N/A	___	HBE	___	%	WAIVER	___	Yes	___	No	___	N/A	___	NABE	___	%	WAIVER	___	Yes	___	No	___	N/A	___
ABE	100	%	WAIVER	___	Yes	___	No	___	N/A	___																																															
AABE	___	%	WAIVER	___	Yes	___	No	___	N/A	___																																															
WBE	___	%	WAIVER	___	Yes	___	No	___	N/A	___																																															
HBE	___	%	WAIVER	___	Yes	___	No	___	N/A	___																																															
NABE	___	%	WAIVER	___	Yes	___	No	___	N/A	___																																															

Chief Administrative Officer



200 South President Street  
Post Office Box 17  
Jackson, Mississippi 39205-0017

Chokwe Antar Lumumba  
*Mayor of the City of Jackson*

## Memorandum

TO: Mayor Lumumba  
FROM: Robert Blain, CAO  
DATE: May 15, 2018

---



The governing authorities previously authorized the Mayor to execute an agreement with Cogent Communications, Inc. Pursuant to the authorization, Cogent was to provide the City of Jackson with 10gig of broadband access. Due to contract provision restrictions, the City was unable to execute an agreement with Cogent outright. Accordingly, the CAO's office would like to clarify its previous request and ask that the Mayor be authorized to execute an agreement with Cogent and instead ask that it be authorized to execute an agreement with LiteCloud. LiteCloud will facilitate Cogent's services with the City.

Office of the City Attorney

455 East Capitol Street  
Post Office Box 2779  
Jackson, Mississippi 39207-2779  
Telephone: (601) 960-1799  
Facsimile: (601) 960-1756

## OFFICE OF THE CITY ATTORNEY

This ORDER CLARIFYING PREVIOUS ORDER AUTHORIZING THE MAYOR TO EXECUTE AN AGREEMENT WITH COGENT COMMUNICATIONS TO MOVE THE CITY OF JACKSON FROM 1 G OF BROADBAND ACCESS TO 10 GIG BROADBAND ACCESS is legally sufficient for placement in NOVUS Agenda.

  
\_\_\_\_\_  
**Sharon D. Gipson**, *City Attorney*  
**Roslyn Griffin**, *Deputy City Attorney* 

5/15/18  
DATE

**ORDER REQUESTING THE CITY COUNCIL REVIEW AND VOTE TO APPROVE THE SIGN VARIANCE REQUEST FOR CRACKER BARREL OLD COUNTRY STORE TO REFACE THEIR EXISTING NONCONFORMING 240 SQ. FT. GROUND SIGN AT 50 FT. IN HEIGHT WITHIN A C-3 ZONE WHICH ONLY ALLOWS GROUND SIGNS TO BE 200 SQ. FT. IN SIZE AND 35 FT. IN HEIGHT (WARD 7)**

OFFICE OF THE CITY ATTORNEY  
4/24/18

**WHEREAS**, the public health, safety or general welfare of the community may require that variances be granted in specific cases as set forth in City of Jackson Sign Ordinance, Sections 102-26, et seq., of the City of Jackson Code of Ordinances; and

**WHEREAS**, pursuant to Section 102-40, no action by the City Council may be taken concerning a variance from the sign regulations until after a public hearing in relation thereto, at which parties in interest and the general citizenry shall have an opportunity to be heard; and

**WHEREAS**, no variance from the Sign Ordinance shall be passed by the City Council unless and until an application seeking the variance is filed with the City's Signs and License Division, with such application containing, at a minimum, a legal description, location map, plot plan, the exact nature of the requested variance, the grounds upon which it is requested, and/or such other information as may be required by the Signs and License Division manager; and

**WHEREAS**, said variance application shall also demonstrate that:

1. Special conditions and circumstances exist which are peculiar to the land, structure, or building involved and which are not applicable to other lands, structures, or buildings in the same district;
2. The literal interpretation of the provisions of the Sign Ordinance would deprive the applicant of rights commonly enjoyed by other properties in the same district under the provisions of the Sign Ordinance;
3. The special conditions and circumstances do not result from actions of the applicant; and
4. Granting the variance requested will not confer upon the applicant any special privilege that is denied by the Sign Ordinance to other similar lands, structures, or buildings in the same district; and

Item #11  
Date: 06/05/18  
By: Kumar, Lumumba

**WHEREAS**, Cracker Barrel Old Country Store, the applicant herein, has requested a variance from the Sign Ordinance regulations to reface their existing nonconforming 240 sq. ft. ground sign at 50 ft. in height within a C-3 zone which only allows ground signs to be 200 sq. ft. in size and 35 ft. in height.

**IT IS THEREFORE, ORDERED** that Cracker Barrel Old Country Store is hereby (*approved*) a variance from the Sign Ordinance regulations to reface their existing nonconforming 240 sq. ft. ground sign at 50 ft. in height within a C-3 zone which only allows ground signs to be 200 sq. ft. in size and 35 ft. in height.

**IT IS FURTHER ORDERED** that the City Council has considered the variance application and grants the variance requested therein based on a finding that special conditions and circumstances exist which are peculiar to the land, structure, or building involved and which are not applicable to other lands, structures, or buildings in the same district; the literal interpretation of the provision of the Sign Ordinance (*would*) deprive the applicant of rights commonly enjoyed by other properties in the same district under the provisions of the Sign Ordinance; the special conditions and circumstances do not result from actions of the applicant; and granting the variance requested (*will not*) confer upon the applicant any special privilege that is denied by the Sign Ordinance to other similar lands, structures, or buildings in the same district.

Item#

Date:

By: Coleman, Kumar, Lumumba

**CITY COUNCIL AGENDA ITEM 10 POINT DATA SHEET**

04/17/18

DATE

<b>POINTS</b>		<b>COMMENTS</b>	
1.	<b>Brief Description/Purpose</b>	To reface their existing nonconforming 240 sq. ft. ground sign at 50 ft. in height within a C-3 zone which only allows ground signs to be 200 sq. ft. in size and 35 ft. in height.	
2.	<b>Public Policy Initiative</b> 1. Youth & Education 2. Crime Prevention 3. Changes in City Government 4. Neighborhood Enhancement 5. Economic Development 6. Infrastructure and Transportation 7. Quality of Life	N/A	
3.	<b>Who will be affected</b>	N/A	
4.	<b>Benefits</b>	N/A	
5.	<b>Schedule (beginning date)</b>	N/A	
6.	<b>Location:</b> ■ WARD ■ CITYWIDE (yes or no) (area) ■ Project limits if applicable	6020 I-55 N WARD 7	
7.	<b>Action implemented by:</b> ■ City Department <input checked="" type="checkbox"/> ■ Consultant <input type="checkbox"/>	Department of Planning & Development Signs & License Division	
8.	<b>COST</b>	N/A	
9.	<b>Source of Funding</b> ■ General Fund <input type="checkbox"/> ■ Grant <input type="checkbox"/> ■ Bond <input type="checkbox"/> ■ Other <input type="checkbox"/>	N/A	
10.	<b>EBO participation</b>	ABE _____%	WAIVER yes ___ no ___ N/A <u>X</u>
		AABE _____%	WAIVER yes ___ no ___ N/A <u>X</u>
		WBE _____%	WAIVER yes ___ no ___ N/A <u>X</u>
		HBE _____%	WAIVER yes ___ no ___ N/A <u>X</u>
		NABE _____%	WAIVER yes ___ no ___ N/A <u>X</u>

Department of Planning and Development



200 South President Street  
Post Office Box 17  
Jackson, Mississippi 39205-0017

## MEMORANDUM

**TO:** Mayor Chokwe Antar Lumumba

**FROM:** Dr. Mukesh Kumar, Director *mkc*  
Department of Planning & Development

**DATE:** April 17, 2018

**RE:** Sign Variance

---

Cracker Barrel Old Country Store, located at 6020 I-55 N, is requesting a variance to reface their existing nonconforming 240 sq. ft. ground sign at 50 ft. in height within a C-3 zone which only allows ground signs to be 200 sq. ft. in size and 35 ft. in height.

Office of the City Attorney

455 East Capitol Street  
Post Office Box 2779  
Jackson, Mississippi 39207-2779  
Telephone: (601) 960-1799  
Facsimile: (601) 960-1756

## OFFICE OF THE CITY ATTORNEY

This ORDER REQUESTING THE CITY COUNCIL REVIEW AND VOTE TO **APPROVE** THE SIGN VARIANCE REQUEST FOR CRACKER BARREL OLD COUNTRY STORE TO REFACE THEIR EXISTING NONCONFORMING 240 SQ. FT. GROUND SIGN AT 50 FT. IN HEIGHT WITHIN A C-3 ZONE WHICH ONLY ALLOWS GROUND SIGNS TO BE 200 SQ. FT. IN SIZE AND 35 FT. IN HEIGHT (WARD 7) is legally sufficient for placement in NOVUS Agenda.

  
\_\_\_\_\_  
**Sharon D. Gipson**, *City Attorney*

**Dana Sims**, *Deputy City Attorney* 

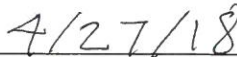
  
\_\_\_\_\_  
DATE



**ORDER REQUESTING THE CITY COUNCIL REVIEW AND VOTE TO DENY THE SIGN VARIANCE REQUEST FOR CRACKER BARREL OLD COUNTRY STORE TO REFACE THEIR EXISTING NONCONFORMING 240 SQ. FT. GROUND SIGN AT 50 FT. IN HEIGHT WITHIN A C-3 ZONE WHICH ONLY ALLOWS GROUND SIGNS TO BE 200 SQ. FT. IN SIZE AND 35 FT. IN HEIGHT (WARD 7)**

OFFICE OF THE CITY ATTORNEY  
KPR  
6/24/18

**WHEREAS**, the public health, safety or general welfare of the community may require that variances be granted in specific cases as set forth in City of Jackson Sign Ordinance, Sections 102-26, et seq., of the City of Jackson Code of Ordinances; and

**WHEREAS**, pursuant to Section 102-40, no action by the City Council may be taken concerning a variance from the sign regulations until after a public hearing in relation thereto, at which parties in interest and the general citizenry shall have an opportunity to be heard; and

**WHEREAS**, no variance from the Sign Ordinance shall be passed by the City Council unless and until an application seeking the variance is filed with the City's Signs and License Division, with such application containing, at a minimum, a legal description, location map, plot plan, the exact nature of the requested variance, the grounds upon which it is requested, and/or such other information as may be required by the Signs and License Division manager; and

**WHEREAS**, said variance application shall also demonstrate that:

1. Special conditions and circumstances exist which are peculiar to the land, structure, or building involved and which are not applicable to other lands, structures, or buildings in the same district;
2. The literal interpretation of the provisions of the Sign Ordinance would deprive the applicant of rights commonly enjoyed by other properties in the same district under the provisions of the Sign Ordinance;
3. The special conditions and circumstances do not result from actions of the applicant; and
4. Granting the variance requested will not confer upon the applicant any special privilege that is denied by the Sign Ordinance to other similar lands, structures, or buildings in the same district; and

Item #12  
Date: 06/05/18  
By: Kumar, Lumumba

**WHEREAS**, Cracker Barrel Old Country Store, the applicant herein, has requested a variance from the Sign Ordinance regulations to reface their existing nonconforming 240 sq. ft. ground sign at 50 ft. in height within a C-3 zone which only allows ground signs to be 200 sq. ft. in size and 35 ft. in height.

**IT IS THEREFORE, ORDERED** that Cracker Barrel Old Country Store is hereby *(denied)* a variance from the Sign Ordinance regulations to reface their existing nonconforming 240 sq. ft. ground sign at 50 ft. in height within a C-3 zone which only allows ground signs to be 200 sq. ft. in size and 35 ft. in height, it being determined that the parties in interest and the general citizenry first had their opportunity to be heard and that the applicant *(has not)* met the necessary criteria for the requested variance.

**IT IS FURTHER ORDERED** that the City Council has considered the variance application and denies the variance requested therein based on a finding that no special conditions and circumstances exist which are peculiar to the land, structure, or building involved and which are not applicable to other lands, structures, or buildings in the same district; the literal interpretation of the provision of the Sign Ordinance *(would not)* deprive the applicant of rights commonly enjoyed by other properties in the same district under the provisions of the Sign Ordinance; the special conditions and circumstances do not result from actions of the applicant; and granting the variance requested *(will)* confer upon the applicant any special privilege that is denied by the Sign Ordinance to other similar lands, structures, or buildings in the same district.

Item#

Date:

By: Coleman, Kumar, Lumumba

**CITY COUNCIL AGENDA ITEM 10 POINT DATA SHEET**

04/17/18

DATE

<b>POINTS</b>		<b>COMMENTS</b>								
1.	<b>Brief Description/Purpose</b>	To reface their existing nonconforming 240 sq. ft. ground sign at 50 ft. in height within a C-3 zone which only allows ground signs to be 200 sq. ft. in size and 35 ft. in height.								
2.	<b>Public Policy Initiative</b> 1. Youth & Education 2. Crime Prevention 3. Changes in City Government 4. Neighborhood Enhancement 5. Economic Development 6. Infrastructure and Transportation 7. Quality of Life	N/A								
3.	<b>Who will be affected</b>	N/A								
4.	<b>Benefits</b>	N/A								
5.	<b>Schedule (beginning date)</b>	N/A								
6.	<b>Location:</b> ■ WARD ■ CITYWIDE (yes or no) (area) ■ Project limits if applicable	6020 I-55 N WARD 7								
7.	<b>Action implemented by:</b> ■ City Department <input checked="" type="checkbox"/> ■ Consultant <input type="checkbox"/>	Department of Planning & Development Signs & License Division								
8.	<b>COST</b>	N/A								
9.	<b>Source of Funding</b> ■ General Fund <input type="checkbox"/> ■ Grant <input type="checkbox"/> ■ Bond <input type="checkbox"/> ■ Other <input type="checkbox"/>	N/A								
10.	<b>EBO participation</b>	ABE	_____ %	WAIVER	yes	___	no	___	N/A	<u>X</u>
		AABE	_____ %	WAIVER	yes	___	no	___	N/A	<u>X</u>
		WBE	_____ %	WAIVER	yes	___	no	___	N/A	<u>X</u>
		HBE	_____ %	WAIVER	yes	___	no	___	N/A	<u>X</u>
		NABE	_____ %	WAIVER	yes	___	no	___	N/A	<u>X</u>

Department of Planning and Development



200 South President Street  
Post Office Box 17  
Jackson, Mississippi 39205-0017

## MEMORANDUM

**TO:** Mayor Chokwe Antar Lumumba

**FROM:** Dr. Mukesh Kumar, Director *mk*  
Department of Planning & Development

**DATE:** April 17, 2018

**RE:** Sign Variance

---

Cracker Barrel Old Country Store, located at 6020 I-55 N, is requesting a variance to reface their existing nonconforming 240 sq. ft. ground sign at 50 ft. in height within a C-3 zone which only allows ground signs to be 200 sq. ft. in size and 35 ft. in height.

Office of the City Attorney



455 East Capitol Street  
Post Office Box 2779  
Jackson, Mississippi 39207-2779  
Telephone: (601) 960-1799  
Facsimile: (601) 960-1756

## OFFICE OF THE CITY ATTORNEY

OFFICE OF THE CITY ATTORNEY  
APR 27 2018

This ORDER REQUESTING THE CITY COUNCIL REVIEW AND VOTE TO **DENY** THE SIGN VARIANCE REQUEST FOR CRACKER BARREL OLD COUNTRY STORE TO REFACE THEIR EXISTING NONCONFORMING 240 SQ. FT. GROUND SIGN AT 50 FT. IN HEIGHT WITHIN A C-3 ZONE WHICH ONLY ALLOWS GROUND SIGNS TO BE 200 SQ. FT. IN SIZE AND 35 FT. IN HEIGHT (WARD 7) is legally sufficient for placement in NOVUS Agenda.

Sharon D. Gipson, City Attorney

Dana Sims, Deputy City Attorney

4/27/18

DATE

OFFICE OF THE CITY ATTORNEY  
5/22/18

**ORDER AUTHORIZING THE MAYOR OR DESIGNEE TO EXECUTE THE APPLICATION AND RELATED DOCUMENTS AND EXECUTE THE AGREEMENT WITH THE UNITED STATES DEPARTMENT OF TRANSPORTATION, FEDERAL TRANSIT ADMINISTRATION FOR THE DISCRETIONARY FY2018 COMPETITIVE FUNDING OPPORTUNITY FOR BUS AND BUS FACILITIES FORMULA PROGRAM SECTION 5339(C) IN THE AMOUNT OF \$6,000,000.00**

**WHEREAS**, the U.S. Department of Transportation, Federal Transit Administration announced on April 23, 2018 the availability for these funds and opened the application process for Section 5339(c) FY 2018 Competitive Funding Opportunity: Bus and Bus Facilities Formula Discretionary Program with the Opportunity Number of FTA-2018-003-LOWNO and;

**WHEREAS**, this is a competitive grant where an application must be submitted by June 23, 2018 to receive these funds; and

**WHEREAS**, these funds will be used to purchase four (4) 35 ft. Low Floor Hybrid (Electric/Diesel) new fixed route buses; and

**WHEREAS**, there is a 15% match required of the City in the amount of \$900,000.00 upon acceptance of these funds; and

**WHEREAS**, the Transit staff is recommending that the City apply for and accept said award for use in the City's transit system and City of Jackson's Transportation Planning and Transit Services Division; and

**IT IS, THEREFORE, ORDERED** that the Mayor is authorized to execute the applications and related documents and execute the agreement with the U.S. Department of Transportation's Federal Transit Administration seeking a grant award of \$6,000,000.00 from Section 5339(c) FY 2018 Competitive Funding Opportunity: Bus and Bus Facilities Formula Discretionary Program with the Opportunity Number of FTA-2018-003-LOWNO to aid in the financing of the City's transit system and the City of Jackson's Transportation Planning and Transit Services Division.

Item# 13  
Agenda Date: May 22, 2018  
By: (Welch, Kumar, Lumumba)

**CITY COUNCIL AGENDA ITEM 10 POINT DATA SHEET 5/22/2018**

POINTS		COMMENTS
1.	<b>Brief Description/Purpose</b>	<b>ORDER AUTHORIZING THE MAYOR OR DESIGNEE TO EXECUTE THE APPLICATION AND RELATED DOCUMENTS AND EXECUTE THE AGREEMENT WITH THE UNITED STATES DEPARTMENT OF TRANSPORTATION, FEDERAL TRANSIT ADMINISTRATION FOR THE DISCRETIONARY FY2018 COMPETITIVE FUNDING OPPORTUNITY FOR BUS AND BUS FACILITIES FORMULA PROGRAM SECTION 5339(C) IN THE AMOUNT OF \$6,000,000.00</b>
2.	<b>Public Policy Initiative</b> <b>1. Youth &amp; Education</b> <b>2. Crime Prevention</b> <b>3. Changes in City Government</b> <b>4. Neighborhood Enhancement</b> <b>5. Economic Development</b> <b>6. Infrastructure &amp; Transportation</b> <b>7. Quality of Life</b>	Infrastructure & Transportation
3.	<b>Who will be affected</b>	All residents of the City of Jackson.
4.	<b>Benefits</b>	This grant will purchase new, low
5.	<b>Schedule (beginning date)</b>	Grant application will occur following council action and mayor's execution of required documents.
6.	<b>Location:</b>	Citywide
7.	<b>Action implemented by: City Department</b>	Department of Planning & Development Transportation Planning Division
8.	<b>COST</b>	\$6,000,000.00
9.	<b>Source of Funding</b> <b>General Fund X</b> <b>Grant X</b> <b>Bond</b> <b>Other</b>	Section 5339(c) FY 2018 Competitive Funding Opportunity: Bus and Bus Facilities Formula Discretionary Program with the Opportunity Number of FTA-2018-003-LOWNO  85%: \$5,100,000.00  General Fund: 187.565.20.6867: \$900,000.00
10.	<b>EBO participation</b>	ABE % WAIVER yes no N/A <u>X</u> AABE % WAIVER yes no N/A <u>X</u> WBE % WAIVER yes no N/A <u>X</u> _HBE % WAIVER yes no N/A <u>X</u> NABE % WAIVER yes no N/A <u>X</u>

# MEMORANDUM

**TO:** Chokwe A. Lumumba, Mayor

**THRU:** Mukesh Kumar, Director *mk*  
Department of Planning & Development

**FROM:** Christine Welch, Deputy Director *CW*  
Office of Transportation

**DATE:** May 10, 2018

**RE:** Agenda Item for May 22, 2018 City Council Meeting

The attached agenda item authorizes the Mayor to execute applications, execute grant agreements and related documents for \$6,000,000.00 to receive the federal funds from the United States Department of Transportation's Federal Transportation Administration (FTA) Section Section 5339(c) FY 2018 Competitive Funding Opportunity: Bus and Bus Facilities Formula Discretionary Program with the Opportunity Number of FTA-2018-003-LOWNO. The grant funds requested are \$6,000,000.

As the recipient of the funds, the City of Jackson agrees that said funds will be used to purchase four (4) 35 ft. Low Floor Hybrid (Electric/Diesel) new fixed route buses.

Said grants would require a total in matching funds in the amount \$900,000.00 from the City of Jackson. Matching funds will be budgeted in the City of Jackson fiscal years when the expenses will be incurred.

If you have any questions, please call Christine Welch, Deputy Director, Office of Transportation at (601) 960-1909 or e-mail [cwelch@jacksonms.gov](mailto:cwelch@jacksonms.gov)



5/22/18

Office of the City Attorney

455 East Capitol Street  
Post Office Box 2779  
Jackson, Mississippi 39207-2779  
Telephone: (601) 960-1799  
Facsimile: (601) 960-1756

## OFFICE OF THE CITY ATTORNEY

OFFICE OF THE CITY ATTORNEY  
5/22/18  
DPS

This ORDER AUTHORIZING THE MAYOR OR DESIGNEE TO EXECUTE THE APPLICATION AND RELATED DOCUMENTS AND EXECUTE THE AGREEMENT WITH THE UNITED STATES DEPARTMENT OF TRANSPORTATION, FEDERAL TRANSIT ADMINISTRATION FOR THE DISCRETIONARY FY2018 COMPETITIVE FUNDING OPPORTUNITY FOR BUS AND FACILITIES FORMULA PROGRAM SECTION 5339(C) IN THE AMOUNT OF \$6,000,000.00 is legally sufficient for placement in NOVUS Agenda.



Sharon D. Gipson, *City Attorney*

Dana Sims, *Deputy City Attorney* 

5/23/18

DATE

**ORDER ACCEPTING THE REQUEST FOR PROPOSAL OF PICADILLY HOLDINGS, LLC TO PROVIDE FOOD CATERING SERVICES TO THE JACKSON POLICE DEPARTMENT RECRUIT CADETS AND TRAINING STAFF.**

OFFICE OF THE CITY ATTORNEY  
D. B. [Signature]  
5/21/18

**WHEREAS**, the City of Jackson Police Department is requesting to receive food catering services from Piccadilly Holdings, LLC (Piccadilly) for providing meals to the 57<sup>th</sup> Jackson Police Department Recruit Class; and

**WHEREAS**, Piccadilly will provide food catering services during the 12 – week recruit training for fifty (50) recruits; and

**WHEREAS**, Piccadilly will provide on-site to the recruit class, breakfast, lunch and dinner, Monday through Thursday, and breakfast and lunch on Fridays; and

**WHEREAS**, Piccadilly has provided the lowest and best proposal for food catering services for fifty recruits (50) at a cost of \$65,916.00 for a term of one (1) year with an automatic extension each year up to three (3) years at the same proposed cost.

**IT IS HEREBY ORDERED**, that the proposal of Piccadilly Holdings, LLC, received April 10, 2018, for a twelve week term for food services, in the amount of \$65,916.00 and not to exceed the amount of \$65,916.00, be accepted as the lowest and best proposal received, it being determined that said proposal met the specifications and needs of the department.

**IT IS FURTHER ORDERED** that the Mayor or his designee be authorized to execute any and all documents necessary to facilitate the terms of the agreement and that payment for said food services be made from the General Fund.

**APPROVED FOR AGENDA:**

Item # \_\_\_\_\_ #14  
Agenda Date: 06/05/18

By: \_\_\_\_\_  
Moore, Lumumba

Jackson Police Department



327 East Pascagoula Street  
Post Office Box 17  
Jackson, Mississippi 39205-0017

## MEMORANDUM

**TO:** Mayor Chokwe A. Lumumba  
**FROM:** Anthony L. Moore, Chief of Police *ALM 5/1/18*  
**DATE:** April 25, 2018  
**RE:** Catering Service

---

The Jackson Police Department (JPD) has received Requests for Proposal (RFP) 93440-041018 from four (4) vendors for catering food for the 57<sup>th</sup> Police Recruit Class.

We have reviewed the bids for service. As a vendor, Piccadilly Holding, LLC, 4273 Robinson, Road, Jackson, MS, has experience from previous recruit classes and provided the lowest quote of the four submissions we received.

Therefore, I am requesting Council approval of the JPD selection of Piccadilly Holding, LLC, as the vendor to provide food service to the 57<sup>th</sup> Recruit Class.

**CITY COUNCIL AGENDA ITEM 10 POINT DATA SHEET**

**April 25, 2018**  
DATE

<b>POINTS</b>	<b>COMMENTS</b>																																													
1. <b>Brief Description/Purpose</b>	Order authorizing the Jackson Police Department (JPD) to enter into an agreement with Piccadilly Holding for food catering services for its upcoming 12 – Week 57 <sup>th</sup> JPD Police Recruit Class.																																													
2. <b>Public Policy Initiative</b> 1. Youth & Education 2. Crime Prevention 3. Changes in City Government 4. Neighborhood Enhancement 5. Economic Development 6. Infrastructure and Transportation 7. Quality of Life	Jackson Police Department																																													
3. <b>Who will be affected</b>	Jackson Police Department (JPD) and the City of Jackson (COJ)																																													
4. <b>Benefits</b>	Jackson Police Department will be able to increase its personnel conducting a 12 –week Police Recruit Class by providing them with nutritious and balanced meals during the rigorous training.																																													
5. <b>Schedule (beginning date)</b>	As Soon As Possible																																													
6. <b>Location:</b> ▪ <b>WARD</b>  ▪ <b>CITYWIDE (yes or no) (area)</b>  ▪ <b>Project limits if applicable</b>	ALL WARDS  CITY WIDE																																													
7. <b>Action implemented by:</b> ▪ <b>City Department</b> <input type="checkbox"/> ▪ <b>Consultant</b> <input type="checkbox"/>	Jackson Police Department Training Academy																																													
8. <b>COST</b>	\$65,916.00																																													
9. <b>Source of Funding</b> ▪ <b>General Fund</b> <input type="checkbox"/> ▪ <b>Grant</b> <input type="checkbox"/> ▪ <b>Bond</b> <input type="checkbox"/> ▪ <b>Other</b> <input type="checkbox"/>	Account # 001-442-266-419																																													
10. <b>EBO participation</b>	<table border="0"> <tr> <td>ABE</td> <td>_____ %</td> <td>WAIVER</td> <td>yes</td> <td>___</td> <td>no</td> <td>___</td> <td>N/A</td> <td>___</td> </tr> <tr> <td>AABE</td> <td>_____ %</td> <td>WAIVER</td> <td>yes</td> <td>___</td> <td>no</td> <td>___</td> <td>N/A</td> <td>___</td> </tr> <tr> <td>WBE</td> <td>_____ %</td> <td>WAIVER</td> <td>yes</td> <td>___</td> <td>no</td> <td>___</td> <td>N/A</td> <td>___</td> </tr> <tr> <td>HBE</td> <td>_____ %</td> <td>WAIVER</td> <td>yes</td> <td>___</td> <td>no</td> <td>___</td> <td>N/A</td> <td>___</td> </tr> <tr> <td>NABE</td> <td>_____ %</td> <td>WAIVER</td> <td>yes</td> <td>___</td> <td>no</td> <td>___</td> <td>N/A</td> <td>___</td> </tr> </table>	ABE	_____ %	WAIVER	yes	___	no	___	N/A	___	AABE	_____ %	WAIVER	yes	___	no	___	N/A	___	WBE	_____ %	WAIVER	yes	___	no	___	N/A	___	HBE	_____ %	WAIVER	yes	___	no	___	N/A	___	NABE	_____ %	WAIVER	yes	___	no	___	N/A	___
ABE	_____ %	WAIVER	yes	___	no	___	N/A	___																																						
AABE	_____ %	WAIVER	yes	___	no	___	N/A	___																																						
WBE	_____ %	WAIVER	yes	___	no	___	N/A	___																																						
HBE	_____ %	WAIVER	yes	___	no	___	N/A	___																																						
NABE	_____ %	WAIVER	yes	___	no	___	N/A	___																																						

Revised 2-04

Office of the City Attorney

455 East Capitol Street  
Post Office Box 2779  
Jackson, Mississippi 39207-2779  
Telephone: (601) 960-1799  
Facsimile: (601) 960-1756

## OFFICE OF THE CITY ATTORNEY

---

This **ORDER ACCEPTING THE REQUEST FOR PROPOSAL OF PICCADILLY HOLDINGS, LLC TO PROVIDE FOOD CATERING SERVICES TO THE JACKSON POLICE DEPARTMENT RECRUIT CADETS AND TRAINING STAFF** is legally sufficient for placement in NOVUS Agenda.

  
\_\_\_\_\_  
**Sharon D. Gipson**, *City Attorney*  
**Gregory Burnett**, *Deputy City Attorney* RB

5/15/18  
\_\_\_\_\_  
DATE

OFFICE OF THE CITY ATTORNEY  
A.R.S.  
5/15/18

4-25 sent to A/C  
Jackson Police Department  



327 East Pascagoula Street  
Post Office Box 17  
Jackson, Mississippi 39205-0017



**Memorandum**

To: Chief Anthony L. Moore *AM 4/26/18*  
Via: Assistant Chief James E. Davis *JD 4/25/18*  
Deputy Chief Joseph Wade, Administration Division *JD 4-25-18*  
From: Commander Herman Horton, Training Academy *HP 4/25/2018*  
Date: April 25, 2018  
Re: **CATERING FOOD SERVICE**

The Jackson Police Department (JPD) received Request for Proposal (RFP) 93440-041018 from the City of Jackson (COJ) Department of Finance. The RFP identified four (4) potential food catering companies to provide food service for fifty (50) recruits and members of the Training Staff during the upcoming JPD police recruit class. The following vendors submitted their RFP by the April 10, 2018 deadline:

1. Piccadilly Holding, LLC 4273 Robinson Rd, Jackson, MS
2. Country Fisherman 3110 Highway 80, Jackson, MS
3. Nick Wallace Culinary 5519 Ridgewood Rd, Jackson, MS
4. Lee Heavenly BBQ, LLC 2130 Belknap Rd, Edwards, MS

Meal	Piccadilly Holding, LLC	Nick Wallace Culinary	Country Fisherman	Lee Heavenly BBQ
Breakfast	\$5.99 = \$1,497.50 wkly	\$21.00 = \$5,250.00 wkly	\$7.00 = \$1,750.00 wkly	\$5.00 = \$1,250.00 wkly
Lunch	\$7.99 = \$1,997.50 wkly	\$23.00 = \$5,750.00 wkly	\$9.00 = \$2,250.00 wkly	\$10.00 = \$2,500.00 wkly
Dinner	\$9.99 = \$1,998.00 wkly	\$25.00 = \$5,000.00 wkly	\$10.00 = \$2,000.00 wkly	\$15.00 = \$3,000.00 wkly
50 meals	\$5,493.00 weekly	\$16,000.00 weekly	\$6,000.00 weekly	\$6,750.00 weekly
12 week	\$65,916.00	\$192,000.00	\$72,000.00	\$81,000.00

The JPD Training Academy selects Piccadilly Holding as the vendor to receive the bid for services based on the following:

- Piccadilly has provided food catering services to the Training Academy in the past.
- Piccadilly has the lowest prices for their services out of all other vendors.

**TERM:** one year with a three (3) year option automatic extension in one year intervals; contract starting around April 2018 or after approval and the selected recruits are in place, but the contract will be for a year to start. The automatic extension will be provided once the services have been required but will be left up to the COJ Police Department and the Training Academy.

  
Commander Herman Horton

## INSTRUCTIONS FOR PREPARING BID/RFP RECOMMENDATION

Please read the following instructions to prepare recommendation.

1. Enclosed in this package are your bid/RFP recommendation instructions, Brochures (if attached) and a copy of the bid tabulation prepared by Purchasing Division. PLEASE DO NOT RETURN BROCHURES OR BID PACKAGES TO PURCHASING.
2. Preparing the recommendation, address your memo as follows:

**TO:** Mayor Chokwe Antar Lumumba  
**FROM:** Requestor Department Director/Department Head  
Name/Department or Division  
**DATE:** The current date when typing the memo  
**SUBJECT:** List the Bid/RFP Description, Bid/RFP Number and Opening Date and/or Term

Example of the Subject Line:

One-Time Bid/RFP: Microcomputers & Software  
Bid/RFP No. 20590-043011  
Opened: April 30, 20011

A Term Bid: Twelve Month Supply of Foods - Dairy Products - Group III  
Bid/RFP No. 37301-043011  
Opened: April 30, 2011  
Term: June 1, 2011 through May 31, 2012

3. The bid recommendation should be prepared ASAP, no later than 5 working days after receipt of the bid tabulation and the related documents.
4. Clearly state in the body of your memo the vendor(s) you are recommending their address, why and the appropriate items. Lowest and best bid being recommended is not necessarily the lowest bid received, detail calculations and a summary statement must be included as a part of your memorandum to justify the recommended purchase (Sec 31-7-13 (d) MS Code 1972 Annotated)
5. If your recommendation is for a one-time bid award, it should clearly state the recommended vendor and a total bid dollar amount being awarded.
6. If your recommendation is for a term bid award, it should clearly state the recommended vendor(s), item by number, by section and item or by the description. The dollar amount is not to be stated for a term bid award.
7. At the conclusion of your memorandum there should be an area for signatures of approval by the following person only: **Department Director, Deputy Director or Division Manager**; unless the memo is from one of them.

8. Now you have completed your recommendation; please send the original recommendation & other documents to the Purchasing Division as indicated below:

- a. Recommendation- prepared by using Department.
- b. 10 Point Data Sheet - prepared & completed by the using Department.
- c. Tabulation Copy- of bid(s)/RFP received provided from Purchasing.
- d. EBO Determination-is provided by the EBO Office though e-mail.
- e. Technical Review Form from Purchasing; requestor should complete & signed.

**9. The Purchasing Division is not connected or set up in the Novus Agenda Routing System to route the Agenda Item. Therefore, Purchasing will prepare the Agenda Item if selected and email a copy to Legal for approval & signature by Legal or to the department to secure & attached in the Novus Agenda System, signifying Purchasing Manager's approval, after clearance to process.**

10. Immediately after the Agenda Order has been approved by Purchasing, it will be emailed to the appropriate person within your department. At that time you will set up the Agenda in the Novus Agenda System to be routed to the various personnel within your department for approval. The attached Agenda Order will have the Purchasing Manager's approval already. Once set up in Novus, attach the Agenda in the Novus Agenda System and route to the following personnel:

Department Director  
Deputy Director  
Division Manager  
Finance  
EBO Office  
Legal Department  
Mayor's Office Representative/CAO

11. The final step is to make sure the Agenda is routed in Novus to the City Clerk's Office to be placed on the City Council's Agenda.



TABULATION OF PROPOSALS RECEIVED FOR LICENSED CATERING FOOD SERVICES  
 TWELVE MONTH CATERING SERVICES W/3 YEAR OPTIONS FOR CITY OF JACKSON POLICE TRAINING ACADEMY  
 CONTRACT STARTING APPROXIMATELY MAY 1, 2018

RFP NO. 93440-041018

ADVERTISED: MARCH 15 & 22, 2018

OPENED: APRIL 10, 2018

JACKSON POLICE DEPARTMENT

		Piccadilly Holdings, LLC Attn: Azam Malik 4273 Robinson Road Jackson, MS 39209 4273 Robinson Road Jackson, MS 39209 (225) 296-8369 amalik@picadilly.com	Nick Wallace Culinary Attn: Nick Wallace 5519 Ridgewood Rd Jackson, MS 39211 5519 Ridgewood Rd Jackson, MS 39211 (601) 919-6328 nick@nickwallaceculinary.com	Country Fisherman Attn: Nate Blount/Joyce Simmons 3110 Highway 80 Jackson, MS 39204 3110 Highway 80 Jackson, MS 39204 (601)944-9933 joycesimmins57@gmail.com	Lee Heavenly BBQ LLC Attn: Benita Myles-Lee 2130 Belknap Rd Edwards, MS 39066 114 Main Street Edwards, MS 39066 (773) 351-1069 grillingqueen@gmail.com
ITEM	DESCRIPTION	UNIT PRICE PER MEAL	UNIT PRICE PER MEAL	UNIT PRICE PER MEAL	UNIT PRICE PER MEAL
<b>OPTION 1-Est. 15-20 meal</b>					
1.	Breakfast	\$5.99	\$26.00	\$7.00	\$5.00
2.	Lunch	\$7.99	\$28.00	\$9.00	\$10.00
3.	Dinner	\$9.99	\$30.00	\$10.00	\$15.00
<b>OPTION 2-Est. 21-30 meal</b>					
ITEM	DESCRIPTION	UNIT PRICE PER MEAL	UNIT PRICE PER MEAL	UNIT PRICE PER MEAL	UNIT PRICE PER MEAL
1.	Breakfast	\$5.99	\$25.00	\$7.00	\$5.00
2.	Lunch	\$7.99	\$27.00	\$9.00	\$10.00
3.	Dinner	\$9.99	\$29.00	\$10.00	\$15.00
<b>OPTION 3-Est. 31-40 meal</b>					
ITEM	DESCRIPTION	UNIT PRICE PER MEAL	UNIT PRICE PER MEAL	UNIT PRICE PER MEAL	UNIT PRICE PER MEAL
1.	Breakfast	\$5.99	\$23.00	\$7.00	\$5.00
2.	Lunch	\$7.99	\$25.00	\$9.00	\$10.00
3.	Dinner	\$9.99	\$27.00	\$10.00	\$15.00

		<p>Piccadilly Holdings, LLC                  Attn: Azam Malik                  4273 Robinson Road                  Jackson, MS 39209                  4273 Robinson Road                  Jackson, MS 39209                  (225) 296-8369  <a href="mailto:amalik@picadilly.com">amalik@picadilly.com</a></p>	<p>Nick Wallace Culinary                  Attn: Nick Wallace                  5519 Ridgewood Rd                  Jackson, MS 39211                  5519 Ridgewood Rd                  Jackson, MS 39211                  (601) 919-6328  <a href="mailto:nick@nickwallaceculinary.com">nick@nickwallaceculinary.com</a></p>	<p>Country Fisherman                  Attn: Nate Blount/Joyce                  Simmons                  3110 Highway 80                  Jackson, MS 39204                  3110 Highway 80                  Jackson, MS 39204                  (601)944-9933  <a href="mailto:joycesimmins57@gmail.com">joycesimmins57@gmail.com</a></p>	<p>Lee Heavenly BBQ LLC                  Attn: Benita Myles-Lee                  2130 Belknap Rd                  Edwards, MS 39066                  114 Main Street                  Edwards, MS 39066                  (773) 351-1069  <a href="mailto:grillingqueen@gmail.com">grillingqueen@gmail.com</a></p>
<b>OPTION 4-Est.41-50 meal</b>					
<u>ITEM</u>	<u>DESCRIPTION</u>	<u>UNIT PRICE PER MEAL</u>	<u>UNIT PRICE PER MEAL</u>	<u>UNIT PRICE PER MEAL</u>	<u>UNIT PRICE PER MEAL</u>
1.	Breakfast	\$5.99	\$21.00	\$7.00	<u>MEAL</u> \$5.00
2	Lunch	\$7.99	\$23.00	\$9.00	\$10.00
3.	Dinner	\$9.99	\$25.00	\$10.00	\$15.00
<b>OPTION 5-Est.51-60 meal</b>					
<u>ITEM</u>	<u>DESCRIPTION</u>	<u>UNIT PRICE PER MEAL</u>	<u>UNIT PRICE PER MEAL</u>	<u>UNIT PRICE PER MEAL</u>	<u>UNIT PRICE PER MEAL</u>
1.	Breakfast	\$5.99	\$20.00	\$7.00	<u>MEAL</u> \$5.00
2.	Lunch	\$7.99	\$22.00	\$9.00	\$10.00
3.	Dinner	\$9.99	\$24.00	\$10.00	\$15.00

			<p>Piccadilly Holdings, LLC  Attn: Azam Malik  4273 Robinson Road  Jackson, MS 39209  4273 Robinson Road  Jackson, MS 39209  (225) 296-8369  amalik@picadilly.com</p>	<p>Nick Wallace Culinary  Attn: Nick Wallace  5519 Ridgewood Rd  Jackson, MS 39211  5519 Ridgewood Rd  Jackson, MS 39211  (601) 919-6328  nick@nickwallaceculinary.com</p>	<p>Country Fisherman  Attn: Nate Blount/Joyce  Simmons  3110 Highway 80  Jackson, MS 39204  3110 Highway 80  Jackson, MS 39204  (601)944-9933  joycesimmins57@gmail.com</p>	<p>Lee Heavenly BBQ LLC  Attn: Benita Myles-Lee  2130 Belknap Rd  Edwards, MS 39066  114 Main Street  Edwards, MS 39066  (773) 351-1069  grillingqueen@gmail.com</p>
<b>OPTION 6-Est.61-70 meal</b>						
<b>ITEM</b>	<b>DESCRIPTION</b>	<b>UNIT PRICE PER MEAL</b>	<b>UNIT PRICE PER MEAL</b>	<b>UNIT PRICE PER MEAL</b>	<b>UNIT PRICE PER MEAL</b>	<b>UNIT PRICE PER MEAL</b>
1.	Breakfast	\$5.99	\$20.00	\$7.00	\$5.00	<u>MEAL</u>
2.	Lunch	\$7.99	\$21.00	\$9.00	\$10.00	
3.	Dinner	\$9.99	\$23.00	\$10.00	\$15.00	
<b>EBO PLAN</b>		<b>An Attachment</b>	<b>An Attachment</b>	<b>An Attachment</b>	<b>An Attachment</b>	<b>An Attachment</b>
Menu Option 2/ wk. opt		Yes	Yes	Yes	Yes	Yes
Liability Ins.		Yes	Yes	Yes	Yes	Yes
Food License		Yes	Yes	Yes	Yes	Yes

HG/js  
04/13/2018



OFFICE OF THE CITY ATTORNEY  
5/17/18

**ORDER AUTHORIZING THE CITY OF JACKSON TO ENTER INTO AN AGREEMENT WITH THE YAZOO CITY POLICE DEPARTMENT FOR THEIR POLICE APPLICANTS TO ATTEND THE 57<sup>TH</sup> BASIC RECRUIT CLASS**

**WHEREAS**, the Yazoo City Police Department (YCPD) desires for their police applicants to participate in the Jackson Police Department 12 week course for the 57<sup>th</sup> Basic Recruit Class; and

**WHEREAS**, the City of Jackson Police Department is requesting authority to train police applicants of the Yazoo City Police Department (YCPD) at the Jackson Police Training Academy as part of its 57<sup>th</sup> Basic Recruit Class; and

**WHEREAS**, the 57<sup>th</sup> Basic Recruit Class commences June 24, 2018 and ends September 14, 2018; and

**WHEREAS**, the City of Jackson Police Department will provide meals, lodging and firearms ammunition for the YCPD recruits; and

**WHEREAS**, the City of Jackson Police Department will not incur any additional cost to train the applicants of the YCPD at the Jackson Police Training Academy; and

**WHEREAS**, YCPD will reimburse the City of Jackson \$3600.00 for each YCPD police recruit that successfully completes the 12 week course; and

**WHEREAS**, the amount of \$3,600.00 includes tuition, meals, ammunition for firearms training, and lodging, for the 12-week course; and

**WHEREAS**, the Jackson Police Training Academy conducts the same 480-hour training curriculum as the other six full-time training academies across the State of Mississippi.

**IT IS, THEREFORE, ORDERED** that the Mayor is authorized to enter into an agreement with the Yazoo City Police Department to enable the Jackson Police Department to provide training for the Yazoo City Police Department recruits and receive reimbursement.

**IT IS FURTHER ORDERED** that the Mayor or his designee is authorized to sign any and all documents to accept reimbursement from the Yazoo City Police Department for training their police recruits.

**APPROVED FOR AGENDA:**

Item # \_\_\_\_\_ #15  
Agenda Date: 06/05/18

By: \_\_\_\_\_ Moore, Lumumba

# CITY COUNCIL AGENDA ITEM 10 POINT DATA SHEET

May 21, 2018

DATE

	<b>P O I N T S</b>	<b>C O M M E N T S</b>
1.	<b>Brief Description/Purpose</b>	Order authorizing the Jackson Police Department and the City of Jackson to enter into an agreement with the Yazoo City Police Department
2.	<b>Public Policy Initiative</b> 1. Youth & Education 2. Crime Prevention 3. Changes in City Government 4. Neighborhood Enhancement 5. Economic Development 6. Infrastructure and Transportation 7. Quality of Life	Jackson Police Department
3.	<b>Who will be affected</b>	Jackson Police Department (JPD and the City of Jackson (COJ)
4.	<b>Benefits</b>	Jackson Police Department will be able to increase its revenue by training applicants of the Yazoo City Police Department along with the recruits of the Jackson Police Department
5.	<b>Schedule (beginning date)</b>	As soon as possible
6.	<b>Location:</b> ▪ WARD  ▪ CITYWIDE (yes or no) (area) ▪ ▪ Project limits if applicable	ALL WARDS  CITY WIDE
7.	<b>Action implemented by:</b> ▪ City Department <input type="checkbox"/> ▪ Consultant <input type="checkbox"/>	Jackson Police Department Training Academy
8.	<b>COST</b>	NA
9.	<b>Source of Funding</b> ▪ General Fund <input type="checkbox"/> ▪ Grant <input type="checkbox"/> ▪ Bond <input type="checkbox"/> ▪ Other <input type="checkbox"/>	No cost is incurred by the City of Jackson (COJ) or the Jackson Police Department for training police recruits from the Yazoo City Police Department.
10.	<b>EBO participation</b>	ABE _____ %      WAIVER    yes ___    no ___      N/A _____ AABE _____ %      WAIVER    yes ___    no ___      N/A _____ WBE _____ %      WAIVER    yes ___    no ___      N/A _____ HBE _____ %      WAIVER    yes ___    no ___      N/A _____ NABE _____ %      WAIVER    yes ___    no ___      N/A _____

Jackson Police Department



327 East Pascagoula Street  
Post Office Box 17  
Jackson, Mississippi 39205-0017

## Memorandum

To: Mayor Chokwe A. Lumumba, City of Jackson

From: Chief Anthony L. Moore, Jackson Police Department *Am 5/15/18*

Date: May 14, 2018

Re: **MEMORANDUM OF UNDERSTANDING (MOU); Jackson Police Department and Yazoo City Police Department**

---

The City of Jackson Police Department will be conducting the 57<sup>th</sup> Basic Recruit Class in June 2018 and I am requesting that applicants from the Yazoo City Police Department be allowed the opportunity to attend the Jackson Police Training Academy.

The qualified applicants from YCPD would participate in the 12-week, 480-hour training course at no cost to the City of Jackson (COJ) and the Jackson Police Department (JPD).

JPD would be reimbursed \$3,600.00 per applicant upon successful completion of the Jackson Police Training Academy. The \$3,600.00 would be reimbursement for tuition, meals, lodging, and firearms ammunition.

I am requesting that all qualified applicants of the YCPD be afforded the opportunity to train at the Jackson Police Training Academy.

5/17/18

Office of the City Attorney

455 East Capitol Street  
Post Office Box 2779  
Jackson, Mississippi 39207-2779  
Telephone: (601) 960-1799  
Facsimile: (601) 960-1756

# OFFICE OF THE CITY ATTORNEY

OFFICE OF THE CITY ATTORNEY  
RBS  
5/12/18

This **ORDER AUTHORIZING THE CITY OF JACKSON TO ENTER INTO AN AGREEMENT WITH THE YAZOO CITY POLICE DEPARTMENT FOR THEIR POLICE APPLICANTS TO ATTEND THE 57TH BASIC RECRUIT CLASS** is legally sufficient for placement in NOVUS Agenda.

  
\_\_\_\_\_  
**Sharon D. Gipson, City Attorney**  
**Gregory Burnett, Deputy City Attorney** *RB*

5/27/18  
DATE

OFFICE OF THE CITY ATTORNEY  
MB  
5/22/18

**ORDER AUTHORIZING THE RENEWAL AND PAYMENT OF THE ANNUAL MAINTENANCE AGREEMENT ON THE AUTOMATED FINGERPRINT IDENTIFICATION SYSTEM.**

**WHEREAS**, the Jackson Police Department has previously purchased an Automated Finger Print Identification System (AFIS) which scans, stores, and reads fingerprints; and

**WHEREAS**, the AFIS requires an annual maintenance agreement to provide unscheduled, on-call emergency remedial maintenance; and

**WHEREAS**, the previous maintenance agreement expired July 2016; and

**WHEREAS**, the Jackson Police Department desires to renew the expired agreement in order to minimize costs associated with repair and maintenance of AFIS.

**WHEREAS**, such maintenance agreement for the period of June 18, 2018 through June 17, 2019 will enable the City of Jackson to continue receiving unscheduled, on-call emergency remedial maintenance; and

**WHEREAS**, the cost to renew the agreement is a onetime reinstatement fee of \$2500.00 with an annual maintenance contract fee of \$6806.10.

**IT IS HEREBY ORDERED** that the City of Jackson Police Department be authorized to pay the amount of \$9306.10 to NEC Corporation of America for the renewal of its annual maintenance agreement on the Automated Fingerprint Identification System (AFIS).

**IT IS FURTHER ORDERED** that the Mayor or his designee be authorized to execute any and all documents necessary to facilitate the terms of the herein-described agreement.

**APPROVED FOR AGENDA:**

Item # \_\_\_\_\_  
Agenda Date: \_\_\_\_\_

#16  
06/05/18

By: MOORE, LUMUMBA





**MEMORANDUM**

**To:** Chokwe A. Lumumba, Mayor

**From:** Anthony L. Moore, Interim Chief of Police *Alon 5/16/18*

**Date:** May 10, 2018

**RE:** Agenda Authorizing Payment of Reinstatement Fee and Maintenance Contract of Annual Software Maintenance Agreement with NEC Corporation of America for the Automated Fingerprint Identification System (AFIS)

---

The attached agenda documents are submitted for the purpose of reinstatement fee and an annual maintenance contract for the maintenance agreement with NEC Corporation for the Automated Fingerprint Identification System (AFIS) for the Jackson Police Department.

The Police Department's Identification Unit utilizes AFIS in its day-to-day operations to scan, sort and read latent fingerprints (crime scene fingerprints). The technology increases case solvability by helping to identify suspects and sharing information with other agencies.

The equipment must receive regular maintenance checks, which are conducted routinely, and upon emergency requests by the vendor, NEC Corporation. Also, by having this coverage, the costs of emergency requests for service, if needed, are minimal as opposed to not having the maintenance agreement.

I recommend we move forward with the reinstatement and the maintenance contract.

CITY COUNCIL AGENDA ITEM 10 POINT DATA SHEET

May 8, 2018  
DATE

POINTS		COMMENTS						
1.	<b>Brief Description/Purpose</b>	Reinstatement and Maintenance of Automated Finger Print Identification System (AFIS) software maintenance agreement.						
2.	<b>Public Policy Initiative</b> 1. Youth & Education 2. Crime Prevention 3. Changes in City Government 4. Neighborhood Enhancement 5. Economic Development 6. Infrastructure and Transportation 7. Quality of Life	Crime Prevention						
3.	<b>Who will be affected</b>	Jackson Police Department						
4.	<b>Benefits</b>	Readable crime scene prints are scanned onto this system and the database is searched for possible suspects.						
5.	<b>Schedule (beginning date)</b>	As soon as possible, upon ratification by City Council						
6.	<b>Location:</b> • WARD  • CITYWIDE (yes or no) (area)  • Project limits if applicable	ALL WARDS  CITY WIDE						
7.	<b>Action implemented by:</b> • City Department D • Consultant D	Jackson Police Department						
8.	<b>COST</b>	\$2500.00; Reinstatement fee \$6806.10; Annual maintenance fee (2018-19)						
9.	<b>Source of Funding</b> • General Fund D • Grant D • Bond D • Other D	001.442.28.6464						
10.	<b>EBO participation</b>	ABE	%	WAIVER	yes	no	NIA	--
		AABE	%	WAIVER	yes	no	NIA	--
		WBE	%	WAIVER	yes	no	NIA	--
		HBE	%	WAIVER	yes	no	NIA	--
		NABE	%	WAIVER	yes	no	NIA	--

5/22/18

Office of the City Attorney

455 East Capitol Street  
Post Office Box 2779  
Jackson, Mississippi 39207-2779  
Telephone: (601) 960-1799  
Facsimile: (601) 960-1756

# OFFICE OF THE CITY ATTORNEY

OFFICE OF THE CITY ATTORNEY  
RB  
5/22/18

This **ORDER AUTHORIZING THE RENEWAL AND PAYMENT OF THE ANNUAL MAINTENANCE AGREEMENT ON THE AUTOMATED FINGERPRINT IDENTIFICATION SYSTEM** is legally sufficient for placement in NOVUS Agenda.



**Sharon D. Gipson**, *City Attorney*  
**Gregory Burnett**, *Deputy City Attorney* RB

5/23/18

DATE

April 10, 2018

Patricia Jackson  
Jackson Police Department  
327 E. Pascagoula Street  
Jackson, MS 39201

Contract: IDS1192

Dear Ms. Jackson:

The term of your maintenance agreement on your NEC AFIS (Automated Fingerprint Identification System) equipment expired June 17, 2017. Due to the lapse in coverage there will be a one-time reinstatement fee of \$2,500 in addition to the Annual Maintenance Charges (AMC). The annual maintenance charges (AMC) for 2018 will be \$6,806.10. Upon confirmation from Jackson Police Department of intent to reinstate the maintenance, NEC will issue a new Maintenance Agreement with complete terms and conditions. Updated service dates will be determined in accordance with the new agreement.

This is not an invoice. Invoices will be sent separately from our billing team.

The NECAM team is proud of our history supporting national, state and local law enforcement in their crucial roles and we are committed to providing you with excellent service and support. NEC appreciates your business and we look forward to fulfilling your future AFIS needs.

Sincerely,

*Cindy Taylor*

Cindy Taylor  
Administrative Support Specialist  
NEC Corporation of America  
Ph: 916-463-7070  
[cindy.taylor@necam.com](mailto:cindy.taylor@necam.com)

**ORDER AUTHORIZING THE JACKSON POLICE DEPARTMENT TO PURCHASE THIRTY IN CAR RADIOS FROM MOTOROLA.**

OFFICE OF THE CITY ATTORNEY  
ZBS  
5/22/18

**WHEREAS**, the City of Jackson Police Department (JPD) desire to purchase thirty (30) In Car Radios for use by the rank and file officers of Patrol Operations; and

**WHEREAS**, the City of Jackson Police Department desire to purchase the thirty (30) In Car Radios from Motorola pursuant to the Mississippi Wireless Information Network (MSWIN) Direct agreement; and

**WHEREAS**, the purchase of the In Car Radios from Motorola will be under the Mississippi Wireless Information Network (MSWIN) Direct Contract Number 3429; and

**WHEREAS**, the In Car Radios are necessary communication equipment for JPD officers for the safety of JPD personnel and the citizens of Jackson; and

**WHEREAS**, the total cost for the Motorola In Car Radios is \$83,940.00, which includes accessories (i.e., battery, Mount, Headset, 36 month warranty).

**IT IS, THEREFORE, ORDERED** that the City of Jackson Police Department is authorized to purchase thirty (30) In Car Radios from Motorola for an amount not to exceed \$83,940.00.

**APPROVED FOR AGENDA:**

Item # \_\_\_\_\_ #17  
Agenda Date: 06/05/18 \_\_\_\_\_  
By: MOORE, LUMUMBA

**CITY COUNCIL AGENDA ITEM 10 POINT DATA SHEET**

**May 22, 2018**

**DATE**

POINTS		COMMENTS						
1.	<b>Brief Description/Purpose</b>	ORDER AUTHORIZING THE PURCHASE OF IN CAR RADIOS FROM MOTOROLA FOR THE JACKSON POLICE DEPARTMENT						
2.	<b>Public Policy Initiative</b> <ol style="list-style-type: none"> <li>1. Youth &amp; Education</li> <li>2. Crime Prevention</li> <li>3. Changes in City Government</li> <li>4. Neighborhood Enhancement</li> <li>5. Economic Development</li> <li>6. Infrastructure and Transportation</li> <li>7. Quality of Life</li> </ol>	Crime Prevention/Quality of Life						
3.	<b>Who will be affected</b>	Citizens of Jackson, Jackson Police Department						
4.	<b>Benefits</b>	To provide for safe and efficient operations.						
5.	<b>Schedule (beginning date)</b>	Upon Council approval						
6.	<b>Location:</b> <ul style="list-style-type: none"> <li>▪ WARD</li> <li>▪ CITYWIDE (yes or no) (area)</li> <li>▪ Project limits if applicable</li> </ul>	ALL Wards  CITY WIDE						
7.	<b>Action implemented by:</b> <ul style="list-style-type: none"> <li>▪ City Department <input type="checkbox"/></li> <li>▪ Consultant <input type="checkbox"/></li> </ul>	Jackson Police Department						
8.	<b>COST</b>	\$84,000.00						
9.	<b>Source of Funding</b> <ul style="list-style-type: none"> <li>▪ General Fund <input type="checkbox"/></li> <li>▪ Grant <input type="checkbox"/></li> <li>▪ Bond <input type="checkbox"/></li> <li>▪ Other <input checked="" type="checkbox"/></li> </ul>	Fund Account No. 302-443606848						
10.	<b>EBO participation</b>	ABE	_____ %	WAIVER	yes ___	no ___	N/A	_____
		AABE	_____ %	WAIVER	yes ___	no ___	N/A	_____
		WBE	_____ %	WAIVER	yes ___	no ___	N/A	_____
		HBE	_____ %	WAIVER	yes ___	no ___	N/A	_____
		NABE	_____ %	WAIVER	yes ___	no ___	N/A	_____

Jackson Police Department



327 East Pascagoula Street  
Post Office Box 17  
Jackson, Mississippi 39205-0017

## MEMORANDUM

To: Chokwe A. Lumumba, Mayor

From: Anthony L. Moore, Chief of Police

Subject: **Purchase of In Car Radios**

Date: May 17, 2018

---

The Jackson Police Department request permission to purchase thirty (30) in car radios and accessories in the amount of \$83,940.00. This purchase will assist in providing necessary communication equipment to promote safety to our personnel and the citizens of Jackson. The radios will be purchased with the Wireless Communication Fund, Account # 302-44360-6848.

We respectfully request your signature approving the document contained herein. Should you have any questions or concerns, please do not hesitate to contact me.

Office of the City Attorney

455 East Capitol Street  
Post Office Box 2779  
Jackson, Mississippi 39207-2779  
Telephone: (601) 960-1799  
Facsimile: (601) 960-1756

## OFFICE OF THE CITY ATTORNEY

---

This **ORDER AUTHORIZING THE JACKSON POLICE DEPARTMENT TO PURCHASE THIRTY IN CAR RADIOS FROM MOTOROLA** is legally sufficient for placement in NOVUS Agenda.

  
\_\_\_\_\_  
**Sharon D. Gipson**, *City Attorney*  
**Gregory Burnett**, *Deputy City Attorney* *RB*

*5/23/18*  
\_\_\_\_\_  
**DATE**

OFFICE OF THE CITY ATTORNEY  
*RB*  
*5/23/18*



**ORDER ACCEPTING THE TERM BIDS OF HEMPHILL CONSTRUCTION COMPANY, UTILITY CONSTRUCTORS, INC., AND DELTA CONSTRUCTORS, INC., FOR LABOR AND EQUIPMENT TO PERFORM VARIOUS PUBLIC WORKS SEWER PROJECTS. [ALL WARDS]**

OFFICE OF THE CITY ATTORNEY  
6/5/18  
21/2018

**WHEREAS**, sealed term bids for Labor & Equipment to perform various Public Works Sewer Projects were opened January 23, 2018, and three (3) bids were received for labor and equipment services for various Public Works Water Projects; and

**WHEREAS**, the Department of Public Works, will use the contractors to perform various water construction projects by providing labor and equipment to the City of Jackson; and

**WHEREAS**, the Department of Public Works, will issue task orders based off prices supplied per bid items to perform various sewer construction projects by providing labor and equipment to the City of Jackson; and

**WHEREAS**, the staff of the Department of Public Works, has reviewed all bids submitted and recommends the governing authorities deem the term bids submitted by Hemphill Construction Company, Inc, P.O Drawer 879, Florence, Mississippi 39073-0879; Utility Constructors, Inc; and Delta Constructors, Inc., P.O. Box 9545, Jackson, MS 39286, received January 23, 2018, as the lowest and best bids to perform various sewer construction projects by providing labor and equipment to the City of Jackson:

Item #18  
Date: 06/05/18  
Miller, Lumumba

**Hemphill Construction Company, Inc, P. O. Drawer 879, Florence, MS 39073-0879,  
Richard Rula, (601) 932-2060, rrula@hemphillconstruction.com**

**Bid Summary**

Part A (Materials, Labor, Equipment)	\$21,448,818.50
Part B (Hourly Rates for Labor & Equipment)	\$ 2,948.00
Total Bid Part A & B	\$21,451,766.50

**Delta Constructors, Inc, P. O. Box 9545, Jackson, MS 39201, Joe H. Campbell, (601) 939-8732, delta9545@aol.com**

**Bid Summary**

Part A (Materials, Labor, Equipment)	\$22,797,877.50
Part B (Hourly Rates for Labor & Equipment)	\$ 3,115.00
Total Bid Part A & B	\$22,800,992.50

**Utility Constructors, Inc, 2262 Maddox Road, Jackson, MS 39236, Terry Lovelace, (601) 922-9355, tlovelace@uci-ms.com**

**Bid Summary**

Part A (Materials, Labor, Equipment)	\$23,725,860.00
Part B (Hourly Rates for Labor & Equipment)	\$ 3,350.00
Total Bid Part A & B	\$23,729,210.00

**IT IS THEREFORE ORDERED** that the **FOLLOWING** bids received for labor & equipment to perform various Public Works Sewer Projects, are accepted as the lowest and best bids for the respective items, it being determined that these bids met the specification.

**IT IS FURTHER ORDERED** that the Mayor is authorized to execute any and all documents necessary for the Department of Public Works to make payments for labor & equipment to perform various Public Works Sewer Projects.

**CITY COUNCIL AGENDA ITEM 10 POINT DATA SHEET**  
**March 16, 2018**

<b>P O I N T S</b>		<b>C O M M E N T S</b>	
1.	<b>Brief Description/Purpose</b>	<b>ORDER ACCEPTING THE TERM BIDS OF HEMPHILL CONSTRUCTION COMPANY, UTILITY CONSTRUCTORS, INC., AND DELTA CONSTRUCTORS, INC., FOR LABOR AND EQUIPMENT TO PERFORM VARIOUS PUBLIC WORKS SEWER PROJECTS. [ALL WARDS]</b>	
2.	<b>Public Policy Initiative</b> 1. Youth & Education 2. Crime Prevention 3. Changes in City Government 4. Neighborhood Enhancement 5. Economic Development 6. Infrastructure and Transportation 7. Quality of Life	This item addresses Items 4, 6, and 7	
3.	<b>Who will be affected</b>	<b>City of Jackson Corporate Limits</b>	
4.	<b>Benefits</b>	<b>Sewer Infrastructure Improvements</b>	
5.	<b>Schedule (beginning date)</b>	When task orders are issued for sewer infrastructure repairs.	
6.	<b>Location:</b> ▪ <b>WARD</b> ▪ <b>CITYWIDE (yes or no) (area)</b> ▪ <b>Project limits if applicable</b>	Citywide	
7.	<b>Action implemented by:</b> ▪ <b>City Department</b> <input checked="" type="checkbox"/> ▪ <b>Consultant</b> <input type="checkbox"/>	<b>This project was implemented by the Engineering Division.</b>	
8.	<b>COST</b>	Cost will be based on task order, and will exceed the total bid submitted by each contractor.	
9.	<b>Source of Funding</b> ▪ <b>General Fund</b> <input checked="" type="checkbox"/> ▪ <b>Grant</b> <input type="checkbox"/> ▪ <b>Bond</b> <input type="checkbox"/> ▪ <b>Other</b> <input type="checkbox"/>	Water/Sewer Revenue Funds	
10.	<b>EBO participation</b>	ABE _____%      WAIVER    yes ___ no ___      N/A ___ AABE _____%      WAIVER    yes ___ no ___      N/A ___ WBE _____%      WAIVER    yes ___ no ___      N/A ___ HBE _____%      WAIVER    yes ___ no ___      N/A ___ NABE _____%      WAIVER    yes ___ no ___      N/A ___	

3/22/18

Office of the City Attorney

455 East Capitol Street  
Post Office Box 2779  
Jackson, Mississippi 39207-2779  
Telephone: (601) 960-1799  
Facsimile: (601) 960-1756

# OFFICE OF THE CITY ATTORNEY

This **ORDER ACCEPTING THE TERM BIDS OF HEMPHILL CONSTRUCTION COMPANY, UTILITY CONSTRUCTORS, INC., AND DELTA CONSTRUCTORS, INC. FOR LABOR AND EQUIPMENT TO PERFORM VARIOUS PUBLIC WORKS SEWER PROJECTS. [ALL WARDS]** is legally sufficient for placement in NOVUS Agenda.



Sharon D. Gipson, *City Attorney*

Terry Williamson, *Legal Counsel*

3/22/18

DATE

3/22/18  
OFFICE OF THE CITY ATTORNEY  
JACKSON, MISSISSIPPI

Department of Public Works



200 South President Street  
Post Office Box 17  
Jackson, Mississippi 39205-0017

Chokwe Antar Lumumba  
*Mayor of the City of Jackson*

**MEMORANDUM**

**To:** Mayor Chokwe Antar Lumumba  
**From:** Robert K. Miller  
Director   
**Date:** March 16, 2018  
**Subject:** Agenda Item for City Council Meeting

Attached you will find an agenda item for accepting the term bid prices from Hemphill Construction Company, Delta Constructors, Inc, and Utility Constructors, Inc.

The City advertised for term bid prices to perform various Public Works Sewer projects. The City received three bids: Hemphill Construction Company, Delta Constructors, Inc, and Utility Constructors, Inc. The City will accept all three bids, and issue task order accordingly to contractors when various sewer infrastructure projects are needed to assist Public Works Crews.

It is the recommendation of Public Works that the bids be accepted. If you have any questions or comments, please do not hesitate to call me at (601) 960-2091.

**ORDER ACCEPTING THE TERM BIDS OF HEMPHILL CONSTRUCTION COMPANY, UTILITY CONSTRUCTORS, INC., AND DELTA CONSTRUCTORS, INC., FOR LABOR AND EQUIPMENT TO PERFORM VARIOUS PUBLIC WORKS WATER PROJECTS. [ALL WARDS]**

OFFICE OF THE CITY CLERK  
- 576-321-3318  
JAN 23 2018

**WHEREAS**, sealed term bids for Labor & Equipment to perform various Public Works Water Projects were opened January 23, 2018, and three (3) bids were received for labor and equipment services for various Public Works Water Projects; and

**WHEREAS**, the Department of Public Works, will use the contractors to perform various water construction projects by providing labor and equipment to the City of Jackson; and

**WHEREAS**, the Department of Public Works, will issue task orders based off prices supplied per bid items to perform various water construction projects by providing labor and equipment to the City of Jackson; and

**WHEREAS**, the staff of the Department of Public Works, has reviewed all bids submitted and recommends the governing authorities deem the term bids submitted by Hemphill Construction Company, Inc, P.O Drawer 879, Florence, Mississippi 39073-0879; Utility Constructors, Inc; and Delta Constructors, Inc., P.O. Box 9545, Jackson, MS 39286, received January 23, 2018, as the lowest and best bids to perform various water construction projects by providing labor and equipment to the City of Jackson:

Item #19  
Date: 06/05/18  
Miller, Lumumba

**Hemphill Construction Company, Inc, P. O. Drawer 879, Florence, MS 39073-0879,  
Richard Rula, (601) 932-2060, rrula@hemphillconstruction.com**

**Bid Summary**

Part A (Materials, Labor, Equipment)	\$21,563,952.50
Part B (Hourly Rates for Labor & Equipment)	\$ 2,948.00
Total Bid Part A & B	\$21,566,900.00

**Delta Constructors, Inc, P. O. Box 9545, Jackson, MS 39201, Joe H. Campbell, (601) 939-8732, delta9545@aol.com**

**Bid Summary**

Part A (Materials, Labor, Equipment)	\$22,553,916.50
Part B (Hourly Rates for Labor & Equipment)	\$ 2,577.00
Total Bid Part A & B	\$22,556,493.50

**Utility Constructors, Inc, 2262 Maddox Road, Jackson, MS 39236, Terry Lovelace, (601) 922-9355, tlovelace@uci-ms.com**

**Bid Summary**

Part A (Materials, Labor, Equipment)	\$23,337,950.00
Part B (Hourly Rates for Labor & Equipment)	\$ 3,390.00
Total Bid Part A & B	\$23,341,340.00

**IT IS THEREFORE ORDERED** that the **FOLLOWING** bids received for labor & equipment to perform various Public Works Water Projects, are accepted as the lowest and best bids for the respective items, it being determined that these bids met the specification.

**IT IS FURTHER ORDERED** that the Mayor is authorized to execute any and all documents necessary for the Department of Public Works to make payments for labor & equipment to perform various Public Works Water Projects.

**CITY COUNCIL AGENDA ITEM 10 POINT DATA SHEET**  
**March 16, 2018**

<b>P O I N T S</b>		<b>C O M M E N T S</b>																																													
1.	<b>Brief Description/Purpose</b>	<b>ORDER ACCEPTING THE TERM BIDS OF HEMPHILL CONSTRUCTION COMPANY, UTILITY CONSTRUCTORS, INC., AND DELTA CONSTRUCTORS, INC., FOR LABOR AND EQUIPMENT TO PERFORM VARIOUS PUBLIC WORKS WATER PROJECTS. [ALL WARDS]</b>																																													
2.	<b>Public Policy Initiative</b> 1. Youth & Education 2. Crime Prevention 3. Changes in City Government 4. Neighborhood Enhancement 5. Economic Development 6. Infrastructure and Transportation 7. Quality of Life	This item addresses Items 4, 6, and 7																																													
3.	<b>Who will be affected</b>	<b>City of Jackson Corporate Limits</b>																																													
4.	<b>Benefits</b>	<b>Water Infrastructure Improvements</b>																																													
5.	<b>Schedule (beginning date)</b>	When task orders are issued for water infrastructure repairs.																																													
6.	<b>Location:</b> ▪ <b>WARD</b> ▪ <b>CITYWIDE (yes or no) (area)</b> ▪ <b>Project limits if applicable</b>	Citywide																																													
7.	<b>Action implemented by:</b> ▪ <b>City Department</b> <input checked="" type="checkbox"/> ▪ <b>Consultant</b> <input type="checkbox"/>	<b>This project was implemented by the Engineering Division.</b>																																													
8.	<b>COST</b>	Cost will be based on task order, and will exceed the total bid submitted by each contractor.																																													
9.	<b>Source of Funding</b> ▪ <b>General Fund</b> <input checked="" type="checkbox"/> ▪ <b>Grant</b> <input type="checkbox"/> ▪ <b>Bond</b> <input type="checkbox"/> ▪ <b>Other</b> <input type="checkbox"/>	Water/Sewer Revenue Funds																																													
10.	<b>EBO participation</b>	<table style="width: 100%; border-collapse: collapse;"> <tr> <td style="width: 15%;">ABE</td> <td style="width: 15%;">_____ %</td> <td style="width: 15%;">WAIVER</td> <td style="width: 10%;">yes</td> <td style="width: 10%;">___</td> <td style="width: 10%;">no</td> <td style="width: 10%;">___</td> <td style="width: 10%;">N/A</td> <td style="width: 10%;">___</td> </tr> <tr> <td>AABE</td> <td>_____ %</td> <td>WAIVER</td> <td>yes</td> <td>___</td> <td>no</td> <td>___</td> <td>N/A</td> <td>___</td> </tr> <tr> <td>WBE</td> <td>_____ %</td> <td>WAIVER</td> <td>yes</td> <td>___</td> <td>no</td> <td>___</td> <td>N/A</td> <td>___</td> </tr> <tr> <td>HBE</td> <td>_____ %</td> <td>WAIVER</td> <td>yes</td> <td>___</td> <td>no</td> <td>___</td> <td>N/A</td> <td>___</td> </tr> <tr> <td>NABE</td> <td>_____ %</td> <td>WAIVER</td> <td>yes</td> <td>___</td> <td>no</td> <td>___</td> <td>N/A</td> <td>___</td> </tr> </table>	ABE	_____ %	WAIVER	yes	___	no	___	N/A	___	AABE	_____ %	WAIVER	yes	___	no	___	N/A	___	WBE	_____ %	WAIVER	yes	___	no	___	N/A	___	HBE	_____ %	WAIVER	yes	___	no	___	N/A	___	NABE	_____ %	WAIVER	yes	___	no	___	N/A	___
ABE	_____ %	WAIVER	yes	___	no	___	N/A	___																																							
AABE	_____ %	WAIVER	yes	___	no	___	N/A	___																																							
WBE	_____ %	WAIVER	yes	___	no	___	N/A	___																																							
HBE	_____ %	WAIVER	yes	___	no	___	N/A	___																																							
NABE	_____ %	WAIVER	yes	___	no	___	N/A	___																																							



3/22/18

Office of the City Attorney

455 East Capitol Street  
Post Office Box 2779  
Jackson, Mississippi 39207-2779  
Telephone: (601) 960-1799  
Facsimile: (601) 960-1756

# OFFICE OF THE CITY ATTORNEY

This ORDER ACCEPTING THE TERM BIDS OF HEMPHILL CONSTRUCTION COMPANY, UTILITY CONSTRUCTORS, INC., AND DELTA CONSTRUCTORS, INC. FOR LABOR AND EQUIPMENT TO PERFORM VARIOUS PUBLIC WORKS WATER PROJECTS. [ALL WARDS] is legally sufficient for placement in NOVUS Agenda.

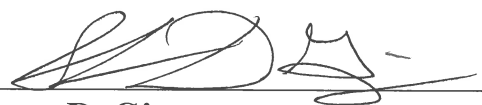

Sharon D. Gipson, *City Attorney*  
Terry Williamson, *Legal Counsel*

3/22/18

DATE

OFFICE OF THE CITY ATTORNEY  
3/22/18

Department of Public Works



200 South President Street  
Post Office Box 17  
Jackson, Mississippi 39205-0017

Chokwe Antar Lumumba  
*Mayor of the City of Jackson*

**MEMORANDUM**

**To:** Mayor Chokwe Antar Lumumba

**From:** Robert K. Miller  
Director 

**Date:** March 16, 2018

**Subject:** Agenda Item for City Council Meeting

Attached you will find an agenda item for accepting the term bid prices from Hemphill Construction Company, Delta Constructors, Inc, and Utility Constructors, Inc.

The City advertised for term bid prices to perform various Public Works Water projects. The City received three bids: Hemphill Construction Company, Delta Constructors, Inc, and Utility Constructors, Inc. The City will accept all three bids, and issue task order accordingly to contractors when various water infrastructure projects are needed to assist Public Works Crews.

It is the recommendation of Public Works that the bids be accepted. If you have any questions or comments, please do not hesitate to call me at (601) 960-2091.

**ORDER ACCEPTING THE BID OF TECHNOLOGY INTERNATIONAL, INC. FOR LOWBOY/FLATBED TRAILER (BID NO. 07051-011618) (ALL WARDS)**

OFFICE OF THE CITY ATTORNEY  
C. Miller  
June 1, 2018  
AMW

**WHEREAS**, the City of Jackson solicited sealed, competitive bids for one Lowboy/Flatbed Trailer; and

**WHEREAS**, two (2) sealed bids were submitted to the City Clerk by January 16, 2018, but inclement weather delayed the opening of bids until January 23, 2018; and

**WHEREAS**, the Department of Public Works reviewed the bids and determined that the bid submitted by Technology International, Inc. is the lowest and best bid and meets bid specifications;

**WHEREAS**, the Department of Public Works recommends that the governing authorities deem the bid of Technology International, Inc., 1349 S International Parkway Ste. 2411, Lake Mary, FL 32746 received January 16, 2018, in the amount of \$43,915.00, the lowest and best bid received.

**IT IS, THEREFORE, ORDERED** that the bid of Technology International Inc. 1349 S Intern. Pkwy, Ste., 2411 Lake Mary, FL. 32746 received on January 16, 2018, in the amount of \$43,915.00, for Lowboy/Flatbed Trailer is accepted as the lowest and best bid received, it being determined that the bid meets City specifications.

AGENDA DATE: #20  
BY: MILLER, LUMUMBA  
06/05/18

**CITY COUNCIL AGENDA ITEM 10 POINT DATA SHEET**

January 17, 2017

<b>P O I N T S</b>		<b>C O M M E N T S</b>
1.	<b>Brief Description</b>	Lowboy/Flatbed Trailer,
2.	<b>Public Policy Initiative</b> 1. Youth & Education 2. Crime Prevention 3. Changes in City Government 4. Neighborhood Enhancement 5. Economic Development 6. Infrastructure and Transportation 7. Quality of Life	4,5,6,7
3.	<b>Who will be affected</b>	City of Jackson's Sewer Maintenance Division
4.	<b>Benefits</b>	Will allow Sewer Maintenance Division to transport Excavators and other Equipment that requires a Low/Boy Flatbed
5.	<b>Schedule (beginning date)</b>	Upon Approval
6.	<b>Location:</b> ■ WARD ■ CITYWIDE (yes or no) (area) ■ Project limits if applicable	Citywide
7.	<b>Action implemented by:</b> ■ City Department <input checked="" type="checkbox"/> Department of Public Works, Water/Sewer Division ■ Consultant <input type="checkbox"/>	
8.	<b>COST</b>	\$ 43,915.00

9.	<b>Source of Funding</b> <input type="checkbox"/> <b>General Fund</b> <input type="checkbox"/> <b>Grant</b> <input type="checkbox"/> <b>Bond</b> <input checked="" type="checkbox"/> <b>Other</b>	<b>Water/Sewer Enterprise Fund</b>
10.	<b>EBO participation</b>	ABE _____% WAIVER yes <input checked="" type="checkbox"/> no _____ N/A _____ AABE _____% WAIVER yes <input checked="" type="checkbox"/> no _____ N/A _____ WBE _____% WAIVER yes <input checked="" type="checkbox"/> no _____ N/A _____ HBE _____% WAIVER yes <input checked="" type="checkbox"/> no _____ N/A _____ NABE _____% WAIVER yes <input checked="" type="checkbox"/> no _____ N/A _____

# Memo

**To:** Mayor Chokwe Antar Lumumba  
**From:** Robert Miller, Public Works Director  
**Date:** 2/26/2018  
**Re:** One-time Bid for Lowboy / Flatbed Trailer. Opened: January 16, 2018 due to weather, open on January 23, 2018. Bid No. 07051-011618

I would like to recommend the best bid to Technology International, Inc., on the above items. They met all the required specifications on the Lowboy/Flatbed Trailer. The grand total is \$43,915.00 for a purchase of the items being awarded.

Technology International, Inc.

<u>ITEM</u>	<u>QTY.</u>	<u>DESCRIPTION</u>	<u>UNIT</u>
1.	1	Lowboy/Flatbed Trailer	\$43,915.00

Per the attached specifications. New Equipment Only, no refurbished.

Total: \$43,915.00

APPROVED:

*Joe Snow*  
Fleet Manager, Municipal Garage

*William Miles*  
Water/Sewer Utilities Manager

*Robert Miller*  
Director, Public Works Department

\_\_\_\_\_  
EBO, Officer



5/11/18

Office of the City Attorney

455 East Capitol Street  
Post Office Box 2779  
Jackson, Mississippi 39207-2779  
Telephone: (601) 960-1799  
Facsimile: (601) 960-1756

# OFFICE OF THE CITY ATTORNEY

OFFICE OF THE CITY ATTORNEY  
5/11/18  
Nakesha Watkins

This ORDER ACCEPTING THE BID OF TECHNOLOGY INTERNATIONAL, INC. FOR LOWBOY/FLATBED TRAILER (BID NO. 070501-011618) (ALL WARDS) is legally sufficient for placement in NOVUS Agenda.

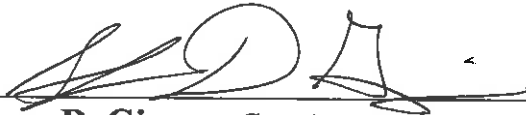

Sharon D. Gipson, *City Attorney*

Nakesha Watkins, *Legal Counsel* NW

5/11/18

DATE

**ORDER ACCEPTING THE TERM BID OF PRECISION  
PACKAGING, INC., FOR A TWENTY-FOUR MONTH SUPPLY  
OF PORTLAND CEMENT, (BID NO. 75021-112117), FOR ALL  
WARDS.**

OFFICE OF THE CITY ATTORNEY  
*April 12, 2018*  
*nmw*

WHEREAS, sealed term bids for a twenty-four month supply of Portland Cement were received November 21, 2017, and

WHEREAS, Maintenance Supply, a Division of the Department of Public Works, will use said cement throughout the City of Jackson on various streets; and

WHEREAS, the staff of Maintenance Supply, a Division of the Department of Public Works, has reviewed the sole bid received and recommends that this governing authority deem the term bid submitted by Precision Packaging Inc., 2805 Meter Road, Jackson, MS 39204, to be the lowest, best and only bid.

IT IS HEREBY ORDERED that the sole term bid received November 21, 2017, from Precision Packaging Inc., for Portland Cement (Bid No. 75021-112117) for a term beginning upon City Council approval and ending twenty-four months later, at a cost of \$9.45 per 92.6 lb. sack and \$9.05 pick-up and 15.00 each pallet, be accepted as the lowest and best bid received, it being determined that said bid met the City specifications.

IT IS FURTHER ORDERED that payment for said Portland Cement be made from the General Fund.

Item#: #21  
06/05/18  
Date: \_\_\_\_\_  
By: Miller, Jones, Greer & Lumumba



**CITY COUNCIL AGENDA ITEM 10 POINT DATA SHEET**

1/23/18 \_\_\_\_\_

DATE

<b>POINTS</b>		<b>COMMENTS</b>			
1.	<b>Brief Description/Purpose</b>	BID FOR SUPPLY FOR TWENTY FOUR MONTHS SUPPLY OF PORTLAND CEMENT.			
2.	<b>Public Policy Initiative</b> 1. Youth & Education 2. Crime Prevention 3. Changes in City Government 4. Neighborhood Enhancement 5. Economic Development 6. Infrastructure and Transportation 7. Quality of Life	4. NEIGHORHOOD ENHANCEMENT 6. INFRASTRUCTURE AND TRANSPORTATION 7. QUALITY OF LIFE			
3.	<b>Who will be affected</b>	SEWER, PAVED STREET, WATER DEPARTMENT, AND THE CITIZEN OF JACKSON			
4.	<b>Benefits</b>	THE CITIZENS OF JACKSON BY MAINTAINING AND IMPROVING CITY FACILITIES. ALSO TO SAVE PROPERTY AND LIVES			
5.	<b>Schedule (beginning date)</b>	UPON CITY COUNCIL APPROVAL THROUGH DECEMBER 2019			
6.	<b>Location:</b> ■ WARD  ■ CITYWIDE (yes or no) (area)  ■ Project limits if applicable	CITYWIDE			
7.	<b>Action implemented by:</b> ■ City Department <input type="checkbox"/> ■ Consultant <input type="checkbox"/>	MAINTENANCE SUPPLY DIVISION OF THE PUBLIC WORKS DEPARTMENT			
8.	<b>COST</b>	ON TABULATION SHEET ATTECHED			
9.	<b>Source of Funding</b> ■ General Fund <input type="checkbox"/> ■ Grant <input type="checkbox"/> ■ Bond <input type="checkbox"/> ■ Other <input type="checkbox"/>	GENERAL FUND			
10.	<b>EBO participation</b>	ABE _____ %	WAIVER	yes ___ no ___	N/A _____
		AABE _____ %	WAIVER	yes ___ no ___	N/A _____
		WBE _____ %	WAIVER	yes ___ no ___	N/A _____
		HBE _____ %	WAIVER	yes ___ no ___	N/A _____
		NABE _____ %	WAIVER	yes ___ no ___	N/A _____

# MEMO

RECEIVED  
PURCHASING DIVISION  
CITY OF JACKSON  
18 JAN 30 PM 1:34

**TO:** MAYOR CHOKWE ANTAR LUMUMBA  
**FROM:** BOB MILLER, PUBLIC WORKS DIRECTOR  
**SUBJECT:** BID NO.75021-112117 TWENTY FOUR MONTH SUPPLY OF PORTLAND CEMENT/TERM: 1/1/2018 THROUGH 12/31/2019  
**DATE:** JANUARY 25, 2018

---

RECOMMEND AWARD BE MADE TO THE BID PER ITEM LISTED BELOW. THE BID IS FROM PRECISION PACKAGE INC., 2805 METER ROAD, JACKSON, AND MS. 39204. PURCHASE WILL BE MADE FROM MAINTENANCE SUPPLY INVENTORY ACCOUNT 1-1502.

**PRECISION PACKAGEING INC., 2805 METER ROAD, JACKSON, MS.**

ITEM 1. PORTLAND CEMENT BY TRUCK TO MAINTENANCE SUPPLY (4225-B MICHAEL AVALON ST) DELIVERED PRICE \$9.45 PER SACK. AND PALLET CHARGES \$15.00

APPROVED:

*Frederick Gates* 1-23-18

---

FREDERICK GATES, PURCHASING MANAGER

*Tony Jones* 1-26-18

---

TONY JONES, DEPUTY DIRECTOR

*Bob Miller* 1/20/2018

---

BOB MILLER, PUBLIC WORKS DIRECTOR

TABULATION OF BID RECEIVED ON A TWENTY-FOUR MONTH SUPPLY OF PORTLAND CEMENT  
 TERM: January 01, 2018 through December 31, 2019  
 BID NO. 75021-112117  
 ADVERTISED: October 26 & November 2, 2017  
 OPENED: November 21, 2017

MAINTENANCE SUPPLY DIVISION  
 DEPARTMENT OF PUBLIC WORKS

ACCOUNT: GENERAL FUND

PURCHASING DIVISION  
 CITY OF JACKSON

18 JAN 23 PM 3:52

<u>ITEM</u>	<u>DESCRIPTION</u>	<u>PRICE PER SACK</u>
I.	Portland Cement in less than Car Load Lots	
	Delivered Price (per sack)	\$9.45
	Number of pounds (per sack)	# 92.6
	Pallet Charges	\$15.00
	Total Price Per Sack Delivery	\$9.45
	Total Per Sack Picked-Up	\$9.05
Bid valid for:		60 days
Delivery:		2 days
EBO Plan Application:		Waiver Included

Precision Packaging Inc.  
 Attn: Tim Kuhn  
 2805 Meter Road  
 Jackson, MS 39204  
 2805 Meter Road  
 Jackson, MS 39204  
 (601) 352-2016  
[Tim.kuhn@ashgrovePKG.Com](mailto:Tim.kuhn@ashgrovePKG.Com)

HG  
 1/23/18



DEPT. COPY  
COPY

CITY OF JACKSON, MISSISSIPPI  
PROPOSAL FORM

PLEASE RETURN THIS SECTION IN ITS ENTIRETY

NOTICE TO BIDDERS:

FOR DELIVERY OR MAILING INSTRUCTIONS:

1. Submit one (1) original and two (2) copies of your Bid Package.
2. MAILING ADDRESS: City Clerk's Office of Jackson  
Post Office Box 17  
Jackson, MS 39205
3. DELIVERY ADDRESS: City Clerk's Office of Jackson  
219 S. President Street  
Jackson, MS 39201
4. Note the following on the outside of your envelope:  
"Bid No. 75021-112117; to be opened November 21, 2017"

In accordance with your Notice of October 26 & November 2, 2017, bid as follows:

Twenty-Four Month Supply of Portland Cement

Term: January 01, 2018 through December 31, 2019

COMPANY NAME <i>Precision Packaging Inc</i>		
ITEM	DESCRIPTION	PRICE PER SACK
1.	Portland Cement in less than Car Load Lots	
	Delivered Price (per sack)	\$ 9.45
	Number of pounds (per sack)	li 92.6
	Pallet Changes	\$ 15.00
	Total Price Per Sack Delivery	\$ 9.45
	Total Per Sack Picked-Up	\$ 9.05

The above will comply with the specifications included in the Notice to Dealers, with any and all exceptions noted in a separate document.

This bid must be valid for 60 days after bid opening. If this bid is good for longer than 60 days, then state how long this bid is good for \_\_\_\_\_.

The above will be delivered F.O.B., prepaid and allowed, Jackson, Mississippi, within 2 days after receipt of your purchase order.

SALES TAX AND FEDERAL EXCISE TAX ARE NOT TO BE INCLUDED IN ABOVE PRICE.  
THE CITY OF JACKSON ASSUMES NO TAX LIABILITY

BID SUBMITTED BY:  
PLEASE TYPE OR PRINT:

Complete Legal Name of Bidder: Precision Packaging Incorporated

Mailing Address: 2805 Meter Road

City: Jackson State: MS Zip Code: 39204

Physical Address, Principal Place of Business: 2805 Meter Road

City: Jackson State: MS Zip Code: 39204

Name of Person Submitting Proposal: Tim Kuhn

Signature of Person Submitting Proposal: [Signature]

Date: November 16, 2017 E-Mail address: Tim.Kuhn.<sup>(Required)</sup>@ashgrove-pkb.com

Telephone No.: 601 352-2016 Fax No.: 601 353-6863

**\*\*The (EBO) Application form must be completed by all vendors and returned with ALL bids. The EBO staff is available at (601) 960-1856 to assist you with any questions you may have in preparing the EBO Application.**

4/12/18

Office of the City Attorney

455 East Capitol Street  
Post Office Box 2779  
Jackson, Mississippi 39207-2779  
Telephone: (601) 960-1799  
Facsimile: (601) 960-1756

# OFFICE OF THE CITY ATTORNEY

OFFICE OF THE CITY ATTORNEY  
APR 12 2018  
NOW

This ORDER ACCEPTING THE TERM BID OF PRECISION PACKAGING, INC., FOR A TWENTY-FOUR MONTH SUPPLY OF PORTLAND CEMENT, (BID NO. 75021-112117), FOR (ALL WARDS) is legally sufficient for placement in NOVUS Agenda.

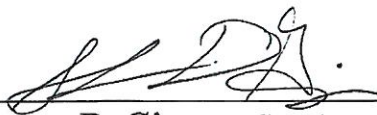

Sharon D. Gipson, *City Attorney*  
Nakesha Watkins, *Legal Counsel* NW

4/17/18

DATE

**ORDER OF CITY COUNCIL OF JACKSON, MISSISSIPPI RESCINDING THE MAY 8, 2018 ORDER AUTHORIZING THE MAYOR TO EXECUTE A PROFESSIONAL SERVICE AGREEMENT WITH RESULT BIZ FOR THE DEVELOPMENT OF AN RFP OF AN ERP SYSTEM.**

**WHEREAS**, the City Council of Jackson, Mississippi considers financial decisions as they are made to cover system changes. At this time, the City Council wishes to look closely at such decisions in determination of its ability to reallocate funds; and

**WHEREAS**, the City Council of Jackson, Mississippi must perform its role as the legislative branch by making fiscally responsible decisions, evaluating the budget, and providing recommendations for cost savings; and

**WHEREAS**, the City Council of Jackson, saw fit to upgrade the current system, Cayenta Financial Software (“JIMS) to Enterprise Resource Planning System (ERP). With that in mind, it was determined that an analysis and execution was recommended to complete the upgrade; and

**WHEREAS**, the City Council of Jackson, Mississippi approved a Professional Services agreement with Results Biz to assist with the analysis and execution with the ERP Steering Committee in creating an RFP for the IT improvements; and

**WHEREAS**, the cost for the professional services of Result Biz is Thirty-Two Thousand Dollars for 800 of IT Professional Services (\$32,000.00); and

**WHEREAS**, the City Council of Jackson, Mississippi now deems this agreement not necessary.

**IT IS THEREFORE ORDERED** that the City Council authorizes the action to rescind the agreement, and all other necessary documents, for a contract with Result Biz to execute IT Professional Services.

Item #22  
Date: 06/05/18  
By: Councilman Stamps



**ORDER OF THE CITY COUNCIL OF JACKSON, MISSISSIPPI  
AUTHORIZING A GRANT TO SUPPORT THE MISSISSIPPI BLACK RODEO  
IN THE AMOUNT OF TEN THOUSAND DOLLARS (\$10,000.00).**

**WHEREAS**, the City Council of the City of Jackson recognizes the historic and cultural significance of the Mississippi Black Rodeo; and

**WHEREAS**, the aim of the Mississippi Black Rodeo is to display support for the Rodeo in the capital city as a great economic impact within the City of Jackson and in the State of Mississippi; and

**WHEREAS**, it is in the best interest of the City of Jackson to support the significance of the Mississippi Black Rodeo.

**THEREFORE, IT IS HEREBY ORDERED** that the City Council of Jackson, Mississippi hereby authorizes the grant to support the Mississippi Black Rodeo in the amount of ten thousand dollars (\$10,000.00).

Item #23

Date: 06/05/18

By: Stamps

**ORDER OF THE CITY COUNCIL OF JACKSON, MISSISSIPPI  
AUTHORIZING THE GRANT TO THE JACKSON MUSIC AWARDS  
IN THE AMOUNT OF TEN THOUSAND DOLLARS (\$10,000.00).**

**WHEREAS, the public health, safety and welfare of the citizens of the City of Jackson shall be considered by this Order; and**

**WHEREAS, the City Council of the City of Jackson recognizes the contribution of the Jackson Music Awards to the quality of life for the citizens of Jackson; and**

**WHEREAS, Jackson Music Awards Association, Inc. began with Rhythm and Blues in 1974; and, with Gospel Music in 1974; and, with Hip Hop in 2005; and**

**WHEREAS, it is in the best interest of the City of Jackson to support the ambassador efforts of the Jackson Music Awards.**

**THEREFORE, IT IS HEREBY ORDERED that the City Council of Jackson, Mississippi hereby authorizes the grant to the Jackson Music Awards in the amount of ten thousand dollars (\$10,000.00).**

**SO ORDERED, this the \_\_\_\_\_ day of May, 2018.**

**Agenda No. #24**

**Agenda Date: May 22, 2018**

**By: STOKES**

**RESOLUTION OF THE CITY COUNCIL OF JACKSON, MISSISSIPPI  
RECOGNIZING AND SUPPORTING THE CELEBRATION OF FATHER'S  
DAY, 2018.**

*W*HEREAS, the idea of celebrating Father's Day grew from the thoughts of Sonora Dodd, a loving daughter from Spokane, whose father, Henry Jackson Smart, single-handedly raised her and five of her siblings following the death of her mother; upon attending a Mother's Day Sermon in 1909, she felt that there should be a corresponding day to honor fathers; she worked relentlessly for years to bring Father's Day to fruition; and

*W*HEREAS, the celebration of Father's Day was begun in 1924 during the administration of former President Calvin Coolidge in order to establish a stronger bond between fathers and children; the idea gained momentum during WWII; President Lyndon B. Johnson proclaimed the third Sunday of June to be Father's Day in 1966, with President Richard Nixon establishing a permanent national observance of Father's Day in 1972; and

*W*HEREAS, according to census data, there are approximately 70.1 million fathers in the U.S.; about 2 million are single fathers; and

*W*HEREAS, observance of Father's Day provides children the opportunity to express love and respect for their fathers; this act is vital to strengthening the father-child relationship and consequently in the emotional development of a child; as we confirm the important role of fathers in nurturing children and building a stronger society, the entire nation and world join the City of Jackson in recognizing and supporting the observance of Father's Day.

**THEREFORE, IT IS HEREBY RESOLVED**, that the City Council of Jackson, Mississippi hereby recognizes and supports the observance of Father's Day, 2018, as we wish for each father a Happy Father's Day.

**SO RESOLVED**, this the 5<sup>th</sup> day of June, 2018.

ITEM NO:   
AGENDA DATE:   
BY: K. STOKES

**RESOLUTION OF THE CITY OF JACKSON, MS IN SUPPORT OF ENTERING INTO A MARKETING LICENSE AGREEMENT WITH THE NATIONAL LEAGUE OF CITIES PARTNERING WITH UTILITY SERVICE PARTNERS, INC. (“USP”) A HOMESERVE COMPANY, IN OFFERING THE NCL SERVICE LINE WARRANTY PROGRAM.**

**WHEREAS**, sewer and water line laterals between the mainlines and the connection on residential private property are owned by individual residential property owners residing in the City ("**Residential Property Owner**"); and

**WHEREAS**, City desires to offer Residential Property Owners the opportunity, but not the obligation, to purchase a service line warranty and other similar products set forth in Exhibit A or as otherwise agreed in writing from time-to-time by the Parties; and

**WHEREAS**, Company, a subsidiary of HomeServe Company, is the administrator of the National League of Cities Service Line Warranty Program and has agreed to make the Products available to Residential Property Owners subject to the terms and conditions contained herein.

**NOW, THEREFORE, BE IT RESOLVED** that the Mayor of the City of Jackson or his designee enter into an agreement with the National League of Cities partnering with Utility Service Partners, Inc., a HomeServe Company, to provide external water service line warranty, external sewer/septic line warranty and interior plumbing and drainage warranty for residents within the City of Jackson.

**“Exhibit A”**  
NLC Service Line Warranty Program  
City of Jackson  
Term Sheet

I. Initial Term. Five years

II. License Fee. \$0.50 per Product for each month that a Product is in force for a Residential Property Owner (and for which payment is received by Company), aggregated and paid annually, for:

- a. City logo on letterhead, advertising, billing, and marketing materials
- b. Signature by City official

III. Brand Fee. \$32,000.00 spread across the first three years of the Term, as follows:

- a. Year 1 - \$16,000.00
- b. Year 2 - \$8,000.00
- c. Year 3 - \$8,000.00

Payment of the Brand Fee for each Year is subject to approval and mailing of the first campaign for that Year and City's timely approval of marketing materials for the prior Year, if relevant.

#### IV. Products.

- a. External water service line warranty (initially, \$5.75 per month)
- b. External sewer/septic line warranty (initially, \$7.75 per month)
- c. Interior plumbing and drainage warranty (initially, \$9.99 per month)

Company may adjust the foregoing Product fees; provided, that any such adjustment shall not exceed \$.50 per month in any 12-month period, unless otherwise agreed by the Parties in writing.

#### V. Scope of Coverage.

- a. External water service line warranty:
  - Homeowner responsibility: From the meter and/or curb box to the external wall of the home.
  - Covers thawing of frozen external water lines.
  - Covers well service lines if applicable.
- b. External sewer/septic line warranty:
  - Homeowner responsibility: From the exit point of the home to the main.
  - Covers septic lines if applicable.
- c. Interior plumbing and drainage warranty:
  - Water supply pipes and drainage pipes within the interior of the home.

VI. Marketing Campaigns. Company shall have the right to conduct up to three campaigns per year. comprised of up to six mailings and such other channels as may be mutually agreed. Initially, Company anticipates offering the Interior plumbing and drainage warranty Product via in-bound channels only.