



REVISED

**REGULAR MEETING OF THE CITY COUNCIL
CITY OF JACKSON, MISSISSIPPI**

May 23, 2023

AGENDA

10:00 AM

CALL TO ORDER BY THE PRESIDENT

INVOCATION

1. **REV. DR. JOHN E. CAMERON, SR OF GREATER MOUNT CALVARY M.B. CHURCH**

PLEDGE OF ALLEGIANCE

PUBLIC HEARING

INTRODUCTIONS

PUBLIC COMMENTS

CONSENT AGENDA

2. **NOTE: "ALL MATTERS LISTED UNDER THE CONSENT AGENDA ARE CONSIDERED TO BE ROUTINE BY THE CITY COUNCIL AND WILL BE ENACTED BY ONE MOTION IN THE FORM LISTED BELOW. THERE WILL BE NO SEPARATE DISCUSSION OF THESE ITEMS. IF DISCUSSION IS DESIRED, THAT ITEM WILL BE REMOVED FROM THE CONSENT AGENDA AND CONSIDERED SEPARATELY."**
3. **APPROVAL OF THE APRIL 24, 2023 SPECIAL ZONING COUNCIL MEETING MINUTES. (S.JORDAN, FOOTE)**
4. **APPROVAL OF THE APRIL 25, 2023 REGULAR COUNCIL MEETING MINUTES. (S.JORDAN, FOOTE)**
5. **APPROVAL OF THE APRIL 27, 2023 SPECIAL COUNCIL/CITIZEN'S AGENDA MEETING MINUTES. (S.JORDAN, FOOTE)**
6. **APPROVAL OF THE MAY 9, 2023 REGULAR COUNCIL MEETING MINUTES. (S.JORDAN, FOOTE)**
7. **APPROVAL OF THE MAY 15, 2023 REGULAR ZONING COUNCIL MEETING MINUTES. (S.JORDAN, FOOTE)**
8. **RESOLUTION DECLARING CERTAIN PARCELS OF REAL PROPERTY IN THE CITY OF JACKSON TO BE A MENACE TO PUBLIC HEALTH,**

SAFETY, AND WELFARE PURSUANT TO SECTION 21-19-11 OF THE MISSISSIPPI CODE AND BASED ON ADMINISTRATIVE HEARINGS HELD ON FEBRUARY 7, 2023 FOR THE FOLLOWING CASES:

21-204	21-494	21-887	22-1054	22-1825	22-2163
21-205	22-716	22-910	22-1386	22-1953	22-2165
22-228	21-788	22-1003	22-1496	22-2034	22-2307
22-431	22-791	22-1011	22-1529	22-2079	22-2319
22-463	21-842	22-1053	21-1648	22-2121	

9. **RESOLUTION DECLARING CERTAIN PARCELS OF REAL PROPERTY IN THE CITY OF JACKSON TO BE A MENACE TO PUBLIC HEALTH, SAFETY, AND WELFARE PURSUANT TO SECTION 21-19-11 OF THE MISSISSIPPI CODE AND BASED ON ADMINISTRATIVE HEARINGS HELD JANUARY 24, 2023 FOR THE FOLLOWING CASES:**

21-526	21-747	22-335	22-1543	22-1809
22-2173	22-2176	21-355	21-475	21-540
21-1177	21-1992	21-2032	21-1193	22-1767

10. **RESOLUTION DECLARING CERTAIN PARCELS OF REAL PROPERTY IN THE CITY OF JACKSON TO BE A MENACE TO PUBLIC HEALTH, SAFETY, AND WELFARE PURSUANT TO SECTION 21-19-11 OF THE MISSISSIPPI CODE AND BASED ON ADMINISTRATIVE HEARINGS HELD MARCH 21, 2023 FOR THE FOLLOWING CASES:**

22-410	23-624	22-2523	22-2106	22-1949
22-1860	22-1199			

11. **RESOLUTION DECLARING CERTAIN PARCELS OF REAL PROPERTY IN THE CITY OF JACKSON TO BE A MENACE TO PUBLIC HEALTH, SAFETY, AND WELFARE PURSUANT TO SECTION 21-19-11 OF THE MISSISSIPPI CODE AND BASED ON ADMINISTRATIVE HEARINGS HELD ON FEBRUARY 28, 2023 FOR THE FOLLOWING CASES:**

22-2427	22-721	21-372	21-612	22-2262	22-1955
22-835	22-116	21-925	21-773	22-1359	23-2
22-336	22-115	21-1216	21-580	21-1483	
22-282	22-670	22-247	21-385	23-180	
22-837	21-462	21-1498	21-671	22-800	

12. **ORDER AUTHORIZING THE MAYOR TO EXECUTE A CONTRACT BETWEEN THE CITY OF JACKSON AND TRIARC MANAGEMENT SERVICES LLC TO DEMOLISH A STRUCTURE, FOUNDATION, STEPS AND DRIVEWAY, TO CUT GRASS AND WEEDS, TO REMOVE TRASH AND DEBRIS, AND TO PERFORM OTHER WORK TO REMEDY THE CONDITIONS ON STATE-OWNED PROPERTY THAT CONSTITUTE A MENACE TO PUBLIC HEALTH, SAFETY, AND WELFARE ACCORDING TO MISSISSIPPI CODE ANNOTATED SECTION 21-19-11 FOR CASE #CE-22-1521 LOCATED AT 245 ARCHER AVE. PARCEL #613-230- \$5,000.00. (WARD 7) (DOTSON, LUMUMBA)**

13. **ORDER AUTHORIZING THE MAYOR TO EXECUTE A CONTRACT BETWEEN THE CITY OF JACKSON AND R & C SERVICES, LLC. TO DEMOLISH THE STRUCTURE, FOUNDATION, STEPS, AND DRIVEWAY; CUT GRASS AND WEEDS; REMOVE TRASH AND DEBRIS; AND REMEDY CONDITIONS ON PRIVATE PROPERTY WHICH CONSTITUTE A MENACE TO PUBLIC HEALTH, SAFETY, AND WELFARE ACCORDING TO MISSISSIPPI CODE ANNOTATED SECTION 21-19-11 FOR CASE #CE-21-685 LOCATED AT 1804 BAILEY AVE. PARCEL #98-129 – \$4,750.00 – WARD 7 (DOTSON, LUMUMBA)**
14. **ORDER AUTHORIZING THE MAYOR TO EXECUTE A CONTRACT BETWEEN THE CITY OF JACKSON AND R & C SERVICES, LLC. TO DEMOLISH THE STRUCTURE, FOUNDATION, STEPS, AND DRIVEWAY; CUT GRASS AND WEEDS; REMOVE TRASH AND DEBRIS; AND REMEDY CONDITIONS ON PRIVATE PROPERTY WHICH CONSTITUTE A MENACE TO PUBLIC HEALTH, SAFETY, AND WELFARE ACCORDING TO MISSISSIPPI CODE ANNOTATED SECTION 21-19-11 FOR CASE #CE-21-1563 LOCATED AT 946 N. CONGRESS ST. PARCEL #39-56– \$8,600.00 – WARD 7 (DOTSON, LUMUMBA)**
15. **ORDER AUTHORIZING THE MAYOR TO EXECUTE A CONTRACT BETWEEN THE CITY OF JACKSON AND LOVE TRUCKING CO., INC. TO DEMOLISH A STRUCTURE, FOUNDATION, STEPS AND DRIVEWAY, TO CUT GRASS AND WEEDS, TO REMOVE TRASH AND DEBRIS, AND TO PERFORM OTHER WORK TO REMEDY THE CONDITIONS ON STATE-OWNED PROPERTY THAT CONSTITUTE A MENACE TO PUBLIC HEALTH, SAFETY, AND WELFARE ACCORDING TO MISSISSIPPI CODE ANNOTATED SECTION 21-19-11 FOR CASE #CE-22-144 LOCATED AT 151 WOODY DR. PARCEL #625-38-2- \$6,400.00. (WARD 7) (DOTSON, LUMUMBA)**
16. **ORDER AUTHORIZING THE MAYOR TO EXECUTE A CONTRACT BETWEEN THE CITY OF JACKSON AND SOCRATES GARRETT ENTERPRISES, INC. TO DEMOLISH THE STRUCTURE, FOUNDATION, STEPS, AND DRIVEWAY; CUT GRASS AND WEEDS; REMOVE TRASH AND DEBRIS; AND REMEDY CONDITIONS ON PRIVATE PROPERTY WHICH CONSTITUTE A MENACE TO PUBLIC HEALTH, SAFETY, AND WELFARE ACCORDING TO MISSISSIPPI CODE ANNOTATED SECTION 21-19-11 FOR CASE #CE-21-866 – 5478 QUEEN MARY LN. – \$5,925.00 – (WARD 4) (DOTSON, LUMUMBA)**
17. **ORDER AUTHORIZING CANCELLATION OF LIEN WITH THE HINDS COUNTY TAX COLLECTOR FOR ADJUDICATED COSTS AND PENALTIES ASSESSED FOR CLEANING PARCEL NUMBER 128-202 LOCATED AT 934 CLAIBORNE AVENUE, JACKSON MISSISSIPPI. (DOTSON, LUMUMBA)**
18. **ORDER ACCEPTING PAYMENT OF \$1,600.42 FROM STATE FARM INSURANCE COMPANY ON BEHALF OF THEIR INSURED ROY DAVIDSON AS A VEHICLE PROPERTY DAMAGE SETTLEMENT. (C.MARTIN, LUMUMBA)**

INTRODUCTION OF ORDINANCES

REGULAR AGENDA

19. **CLAIMS (MALEMBEKA, LUMUMBA)**
20. **PAYROLL (MALEMBEKA, LUMUMBA)**
21. **ORDER CONFIRMING THE MAYOR'S APPOINTMENT OF SHARON THAMES AS DIRECTOR OF THE DEPARTMENT OF ADMINISTRATION, CITY OF JACKSON, MISSISSIPPI. (LUMUMBA)**
22. **ORDER AUTHORIZING THE MAYOR TO EXECUTE AN AGREEMENT WITH eCIVIS, Inc FOR SERVICES RELATED TO THE IMPLEMENTATION OF A GRANTS NETWORK SYSTEM AND SUBSCRIPTION TO THE CLOUD HOSTED SaaS GRANTS MANAGEMENT PLATFORM. (LUMUMBA)**
23. **ORDER AUTHORIZING THE MAYOR TO EXECUTE A MEMORANDUM OF UNDERSTANDING WITH THE PRESIDENT AND FELLOWS OF HARVARD COLLEGE ACTING THROUGH THE TAUBMAN CENTER FOR STATE AND LOCAL GOVERNMENT AT THE HARVARD KENNEDY SCHOOL REGARDING THE GOVERNMENT INNOVATION FELLOW AND GOVERNMENT PERFORMANCE LAB. (LUMUMBA)**
24. **ORDER REVISING THE FISCAL YEAR 2023 MUNICIPAL BUDGET FOR THE CITY OF JACKSON POLICE DEPARTMENT. (DAVIS, LUMUMBA)**
25. **ORDER ACCEPTING THE BID OF ACTIVE SOLUTIONS, LLC FOR A THIRTY-SIX (36) MONTH SUPPLY OF SAFECITYCAM SURVEILLANCE CAMERAS AND INSTALLATION AND AUTHORIZING THE MAYOR TO EXECUTE A SALES AGREEMENT BETWEEN THE CITY OF JACKSON AND ACTIVE SOLUTIONS, LLC. (DAVIS, LUMUMBA)**
26. **ORDER AUTHORIZING THE CONTRIBUTION OF MATCHING FUNDS TO VARIOUS ORGANIZATIONS FOR THE PURPOSE OF SUPPORTING THE DEVELOPMENT OF THE ARTS OR SOCIAL AND COMMUNITY SERVICE PROGRAMS AND AUTHORIZING THE MAYOR TO EXECUTE CONTRACTS WITH THE ENTITIES RECEIVING MATCHING FUNDS. (WRIGHT, LUMUMBA)**
27. **ORDER AUTHORIZING THE MAYOR TO ENTER INTO AN AGREEMENT WITH CREATIVE RESEARCH SOLUTIONS (CRS) TO SERVE AS CONSULTANT FOR THE CITY OF JACKSON TO CONDUCT EVALUATION ASSESSMENTS FOR THE W.K. KELLOGG FOUNDATION-FUNDED PROJECT, ECONOMIC PATHWAYS TO HUMAN DIGNITY: BUILDING OCCUPATIONAL OPPORTUNITIES & ECONOMIC GROWTH (EPHD). (DOTSON, LUMUMBA)**
28. **ORDER RATIFYING AND AUTHORIZING THE MAYOR TO ENTER INTO AN AGREEMENT WITH SERVICEMASTER COMMERCIAL CLEANING OF JACKSON TO PROVIDE JANITORIAL SERVICES AND SUPPLIES FOR THE ADMINISTRATION BUILDING AND CUSTOMER SERVICE OFFICE (UNION STATION) OF THE CITY OF JACKSON'S PUBLIC TRANSPORTATION SYSTEM (JTRAN) COMMENCING MAY 1, 2023. (DOTSON, LUMUMBA)**
29. **ORDER AUTHORIZING THE EXECUTION OF A MEMORANDUM OF UNDERSTANDING BETWEEN THE CITY OF JACKSON AND HOPE ENTERPRISE CORPORATION TO PARTICIPATE IN THE DIVERSITY PILOT PROGRAM. (DOTSON, LUMUMBA)**

30. **ORDER DECLARING PARCEL NUMBER 112-1 SURPLUS PROPERTY AND AUTHORIZING THE MAYOR TO EXECUTE THE DEED OF CONVEYANCE AND OTHER DOCUMENTS NECESSARY TO DONATE SAID PROPERTY TO JACKSON RESOURCE CENTER FOR THE DEVELOPMENT OF A TRANSITIONAL HOUSING CENTER. (DOTSON, LUMUMBA)**
31. **ORDER AMENDING THE FISCAL YEAR 2022-2023 BUDGET OF THE CITY OF JACKSON DEPARTMENT OF INFORMATION TECHNOLOGY. (REID, LUMUMBA)**
32. **ORDER AUTHORIZING THE MAYOR TO EXECUTE A FORTY-EIGHT (48) MONTH RENTAL AGREEMENT WITH ADVANTAGE BUSINESS SYSTEMS FOR A KONICA MINOLTA BIZHUB C750i DIGITAL BLACK/WHITE AND COLOR SYSTEM AND THE KONICA MINOLTA BIZHUB 4750i DIGITAL (BLACK/WHITE) TO BE USED BY THE DEPARTMENT OF PUBLIC WORKS. (R.LEE, LUMUMBA)**
33. **ORDER RATIFYING CONTRACTS RELATED TO THE EMERGENCY REPAIRS TO THALIA MARA HALL AND THE ARTS CENTER OF MISSISSIPPI IN PREPARATION FOR THE U.S.A. INTERNATIONAL BALLET COMPETITION. (R.LEE, LUMUMBA)**
34. **ORDER RATIFYING A CONTRACT WITH MS TIRE RECYCLING FOR TIRE COLLECTION AND RECYCLING FOR THE SOLID WASTE DIVISION OF THE DEPARTMENT OF PUBLIC WORKS AND AUTHORIZING PAYMENT. (R.LEE, LUMUMBA)**
35. **ORDER AUTHORIZING THE MAYOR TO EXECUTE AN AGREEMENT WITH THE PUBLIC RIGHTS PROJECT TO REPRESENT THE CITY IN CHALLENGING THE LEGALITY OF ACTIONS TAKEN DURING THE 2023 MISSISSIPPI LEGISLATIVE SESSION. (C.MARTIN, LUMUMBA)**
36. **ORDER AUTHORIZING THE MAYOR TO EXECUTE A RENEWAL CONTRACT WITH TIM HOWARD TO PROVIDE INDIGENT DEFENDER LEGAL SERVICES FOR THE CITY OF JACKSON, MISSISSIPPI. (C.MARTIN, LUMUMBA)**
37. **ORDER AUTHORIZING PAYMENT OF \$30,000.00 TO THE ESTATE OF REGUS MCCULLEN AS FULL AND COMPLETE SETTLEMENT OF PROPERTY CLAIM. (C.MARTIN, LUMUMBA)**
38. **ORDER AUTHORIZING THE MAYOR TO EXECUTE A CONTRACT WITH KAYLA POWER TO SERVE AS A LEGAL INTERN FOR THE OFFICE OF THE CITY ATTORNEY. (C.MARTIN, LUMUMBA)**
39. **ORDER REVIEWING AND CONTINUING AUGUST 29, 2022 STATE OF EMERGENCY. (C.MARTIN, LUMUMBA)**
40. **RESOLUTION OF THE CITY COUNCIL OF JACKSON, MISSISSIPPI HONORING, RECOGNIZING AND SUPPORTING THE ANNUAL JUNETEENTH FREEDOM AND UNITY CULTURAL CELEBRATION. (STOKES)**
41. **ORDER REVIEWING AND CONTINUING STATE OF EMERGENCY. (JACKSON CITY COUNCIL)**
42. **RESOLUTION OF CITY COUNCIL OF JACKSON, MISSISSIPPI IN SUPPORT OF RECOGNIZING THE MONTH OF MAY AS NATIONAL**

TENNIS MONTH AND HONORING MS. VENECCA GREEN FOR HER EFFORTS TO PROMOTE TENNIS TO CITIZENS OF JACKSON, MISSISSIPPI AT BATTLEFIELD PARK. (JACKSON CITY COUNCIL)

DISCUSSION

43. **DISCUSSION: REVIEW AND CONTINUATION OF COVID-19 LOCAL EMERGENCY (JACKSON CITY COUNCIL)**
44. **DISCUSSION: JMAA (LUMUMBA)**
45. **DISCUSSION: LITIGATION (C.MARTIN)**

PRESENTATION

PROCLAMATION

RESOLUTIONS

REPORT FROM MEMBERS, MAYOR, DEPARTMENT DIRECTORS

46. **MONTHLY FINANCIAL REPORTS AS REQUIRED ACCORDING TO SECTION 21-35-13 OF THE MISSISSIPPI CODE ANNOTATED OF 1972.**

ANNOUNCEMENTS

ADJOURNMENT

AGENDA ITEMS IN COMMITTEE

Consent

Agenda

#3

BE IT REMEMBERED that a Special Zoning Meeting of the City Council of Jackson, Mississippi was convened in the Council Chambers in City Hall at 2:30 p.m. on April 24, 2023, being the fourth Monday of said month when and where the following things were had and done to wit:

Present: Council Members: Ashby Foote, Council President, Ward 1; Brian Grizzell, Ward 4 (via teleconference); Vernon Hartley, Ward 5 (via teleconference) and Aaron Banks, Ward 6. Directors: Sabrina Shelby, Chief Deputy Clerk of Council; Victor Allen, Chief Deputy Clerk of Council; Ester Ainsworth, Zoning Administrator and Kristie Metcalfe, Deputy City Attorney.

Absent: Angelique Lee, Vice President, Ward 2; Kenneth I. Stokes, Ward 3 and Virgi Lindsay, Ward 7.

* * * * *

The meeting was called to order by **President Ashby Foote**.

* * * * *

President Foote recognized Zoning Administrator **Ester Ainsworth** who provided the Council with a procedural history of Zoning Case No. 4203, including all applicable ordinances, statutes, and a brief review of documents included in the Council agenda packets which were the applicable zoning map, future land use map, photos of the subject area, staff report, application with exhibits and planning board meeting minutes.

President Foote requested that the Clerk read the Order:

ORDER GRANTING HARVEY WILLIAMS SR. A SPECIAL EXCEPTION TO ALLOW FOR A RESIDENTIAL COMMUNITY FACILITY WITHIN A R-1 (SINGLE-FAMILY) RESIDENTIAL DISTRICT FOR THE PROPERTY LOCATED AT 5129 ANDOVER DR. (PARCEL 640-428) CASE NO. 4203.

WHEREAS, Harvey Williams Sr. has filed a petition for a Special Exception to allow for a residential community facility within a R-1 (Single-Family) Residential District for the property located at 5129 Andover Dr. (Parcel 640-428), in the City of Jackson, First Judicial District of Hinds County, Mississippi; and

WHEREAS, the Jackson City Planning Board, after holding the required public hearing has recommended approval of a Special Exception to allow for a residential community facility within a R-1 (Single-Family) Residential District; and

WHEREAS, notice was duly and legally given to property owners and interested citizens that a meeting of the Jackson City Council would be held at the City Hall at 2:30 p.m., April 17, 2023 to consider said petition based upon the record of the case as developed before the Jackson City Planning Board; and

WHEREAS, it appeared to the satisfaction of the Jackson City Council that notice of said petition had been published in the Mississippi Link on March 2, 2023 and March 16, 2023 that a hearing had been held by the Jackson City Planning Board on March 22, 2023, as provided for by ordinances of the City of Jackson and the laws of the State of Mississippi, and that the Jackson City Planning Board had recommended approval of a Special Exception for the above described property within an existing R-1 (Single-Family) Residential Zoning District of the City of Jackson; and

WHEREAS, it appears to the Jackson City Council that the documents are in order and that the recommendation of the Planning Board to approve a Special Exception to allow for a residential community facility within a R-1 (Single-Family) Residential District does support the promotion of the public health, safety, morals, the general welfare of the community and the granting of such will not adversely affect adjacent property owners.

NOW, THEREFORE, BE IT ORDERED BY THE COUNCIL OF THE CITY OF JACKSON, MISSISSIPPI:

That the property located in the First Judicial District of Hinds County, Jackson, Mississippi, and being more particularly described as follows:

Lot Sixty-five (65), Clinton Boulevard Subdivision, part 5, a subdivision according to a map or plat thereof which is on file and of record in the office of the Chancery Clerk of Hinds County at Jackson, Mississippi, in Plat Book 16 at Page 40 thereof, reference to which is hereby made in aid of and as a part of this description.

be and is hereby granted a Special Exception to allow for a residential community facility within a R-1 (Single-Family) Residential District for the property located at 5129 Andover Dr. (Parcel 640-428). However, that before for any structure is erected or use thereof on the said property, the applicant must meet the requirements established through the Site Plan Review process.

Council Member Banks moved adoption; **Council Member Hartley** seconded.

President Foote recognized **Harvey Williams Sr., Applicant**, who spoke in favor of a Special Exception for a residential community facility in a R-1 (Single-Family) Residential District.

There was no opposition from the public.

Thereafter, **President Foote** called for a vote on said item:

- Yeas – Banks, Foote, Grizzell and Hartley.
- Nays – None.
- Absent – Lee, Lindsay and Stokes.

Cancelled Special Exceptions\Use Permits – No Action Required

(Ward 3) SE 2905 – Mary Tillman – 3651 Moseley Avenue. – (Parcel 425-353)

- SE was granted to Mary Tillman on April 4, 1992 to operate a Personal Care Facility for up to Twelve (12) Residents within an R-4 (Limited Multi-Family) Residential District.
- Cancellation was based upon **non-response** from the grantee by the deadline date **April 3, 2023**.

ORDER GRANTING EXTENSION OF SPECIAL EXCEPTIONS AND USE PERMITS FOR ONE YEAR.

Coming for consideration are requests for the approval of the following for certification of renewal for one year and after the anniversary date of approval for Use Permit or Special Exceptions as follows:

<u>CASE NO.</u>	<u>NAME</u>	<u>LOCATION</u>	<u>USE</u>	<u>GRANTED</u>
SE – 3290 Ward 2	Southern Consultants	5740 County Cork Rd.	Engineering Office	03/01/90
SE –3048 Ward 4	Deborah Harper	405 Queen Margaret Lane	One-Chair Beauty Salon	4/5/95

**SPECIAL ZONING MEETING OF THE CITY COUNCIL
MONDAY, APRIL 24, 2023 2:30 P.M.**

C-UP-3894 Ward 1	Meena Sabharwal	1625 E. County Line Rd. - Suite 320 Jackson, MS 39206	Operation of a Liquor Store	4/20/15
SE - 3962 Ward 7	Morrison Heights Baptist Church	142 E. Bell St.	Residential Community Facility	4/17/17
C-UP-4168 Ward 3	Byron & Octavia Poindexter	210 & 212 W. Ash St.	Rooming House	4/18/22

IT IS HEREBY ORDERED by the Council of the City of Jackson that the said Use Permits and/or Special Exceptions be and the same are hereby extended for another year from and after the anniversary date granting said permits.

Council Member Banks moved adoption; **Council Member Lindsay** seconded.

Yeas – Banks, Foote, Grizzell and Hartley.
Nays – None
Absent – Lee, Lindsay, and Stokes.

There being no further business to come before the City Council, it was unanimously voted to adjourn until the next Regular Council Meeting to be held at 10:00 a.m. on Tuesday, April 25, 2023. At 3:15 p.m., the Council stood adjourned.

PREPARED BY:

APPROVED:

CLERK OF COUNCIL

_____,
COUNCIL PRESIDENT DATE

MAYOR

ATTEST:

CITY CLERK

#4

**REGULAR MEETING OF THE CITY COUNCIL
TUESDAY, APRIL 25, 2023 10:00 A.M.**

BE IT REMEMBERED that a Regular Meeting of the City Council of Jackson, Mississippi, was convened at City Hall at 10:00 a.m. on April 25, 2023, being the fourth Tuesday of said month, when and where the following things were had and done to wit:

Present: Council Members: Ashby Foote, Council President, Ward 1; Angelique Lee, Vice-President, Ward 2; Brian Grizzell, Ward 4; Vernon Hartley, Ward 5; Aaron Banks, Ward 6 and Virgi Lindsay, Ward 7. Directors: Chokwe Antar Lumumba, Mayor; Shanekia Mosley-Jordan, Clerk of Council; Sabrina Shelby, Chief Deputy Clerk of Council and Catoria Martin, City Attorney.

Absent: Kenneth Stokes, Ward 3.

The meeting was called to order by **President Foote**.

The invocation was offered by **Dr. David Strain of First Presbyterian Church of Jackson**.

The Council recited the **Pledge of Allegiance**.

APPROVAL OF THE MARCH 30, 2023 SPECIAL COUNCIL MEETING MINUTES.

Vice President Lee moved adoption; **Council Member Lindsay** seconded.

Yeas – Banks, Foote, Grizzell, Hartley, Lee and Lindsay.
Nays – None.
Absent – Stokes.

APPROVAL OF THE MARCH 30, 2023 SPECIAL COUNCIL/CITIZEN'S AGENDA MEETING MINUTES.

Vice President Lee moved adoption; **Council Member Lindsay** seconded.

Yeas – Banks, Foote, Grizzell, Hartley, Lee and Lindsay.
Nays – None.
Absent – Stokes.

APPROVAL OF THE APRIL 1, 2023 SPECIAL COUNCIL MEETING MINUTES.

Vice President Lee moved adoption; **Council Member Lindsay** seconded.

Yeas – Banks, Foote, Grizzell, Hartley, Lee and Lindsay.
Nays – None.
Absent – Stokes.

**Consent Agenda Item No. 4
May 23, 2023
(S.Jordan, Foote)**

ORDER AUTHORIZING THE MAYOR TO EXECUTE A CONTRACT BETWEEN THE CITY OF JACKSON AND TRIARC MANAGEMENT SERVICES, LLC TO CUT GRASS AND WEEDS; REMOVE TRASH AND DEBRIS; AND REMEDY CONDITIONS ON PRIVATE PROPERTY WHICH CONSTITUTE A MENACE TO PUBLIC HEALTH, SAFETY, AND WELFARE ACCORDING TO MISSISSIPPI CODE ANNOTATED SECTION 21-19-11 FOR CASE #CE-21-818 – 3150 TOUGALOO STREET – \$1,200.00.

WHEREAS, on September 13, 2022, the Jackson City Council approved a resolution declaring certain parcels of real property in the City of Jackson to be a menace to public health, safety, and welfare pursuant to Section 21-19-11 of the Mississippi Code following an administrative hearing held on August 9, 2022 for Case #CE-21-818 located in Ward 5 of the City of Jackson; and

WHEREAS, the Community Improvement Division of the Planning and Development Department maintains a list of licensed, bonded, and insured contractors that received and responded to the request for bids for the project located at 3150 Tougaloo St. and

WHEREAS, Triarc Management Services LLC, submitted the lowest bid of \$1,200.00; and

WHEREAS, a municipal contract for the professional services of a contractor is not subject to advertising and bidding requirements set forth in Section 31-7-13 of the Mississippi Code of 1972; and

WHEREAS, upon receipt of a written Notice to Proceed, Triarc Management Services LLC. through its representative, Stacey Stowers, has agreed to cut grass, weeds, shrubbery, fence line, bushes, and saplings; remove trash, debris, tires, fallen tree parts, wooden boards, crates, appliances, old furniture, building materials, old bricks and clean curbside; and remedy conditions constituting a menace to public health, safety, and welfare for the parcel located at 3150 Tougaloo St. in an amount not to exceed \$1,200.00; and

WHEREAS, Triarc Management Services LLC. has a principal office located at 644 E. Rhinewalt Rd. Lena, MS 39094, according to the information appearing on the Mississippi Secretary of State's website.

IT IS, THEREFORE, ORDERED that the Mayor is authorized to execute a contract with Triarc Management Services, LLC upon receipt of a written Notice to Proceed, to cut vegetation and remedy conditions on the property located at 3150 Tougaloo St. deemed to be a menace to public health, safety, and welfare.

IT IS FURTHER HEREBY ORDERED that a sum not to exceed \$1,200.00 shall be paid to Triarc Management Services, LLC upon the completion of the services provided from funds budgeted for the Division.

Vice President Lee moved adoption; **Council Member Lindsay** seconded.

Yeas – Banks, Foote, Grizzell, Hartley, Lee and Lindsay.

Nays – None.

Absent – Stokes.

* * * * *

ORDER AUTHORIZING THE MAYOR TO EXECUTE A CONTRACT BETWEEN THE CITY OF JACKSON AND QUALITYLANDSCAPE & LAWN MAINTENANCE INC, TO BOARD UP AND SECURE THE STRUCTURE(S) AND/OR CUT GRASS AND WEEDS; REMOVE TRASH AND DEBRIS; AND REMEDY CONDITIONS ON PRIVATE PROPERTY WHICH CONSTITUTE A MENACE TO PUBLIC HEALTH, SAFETY, AND WELFARE ACCORDING TO MISSISSIPPI CODE ANNOTATED SECTION 21-19-11 FOR CASE #CE- 21-1333 306 FORD AVE. – \$1,247.00.

WHEREAS, on July 5, 2022, the Jackson City Council approved a resolution declaring certain parcels of real property in the City of Jackson to be a menace to public health, safety, and welfare pursuant to Section 21-19-11 of the Mississippi Code following an administrative hearing held on June 14, 2022 for Case #CE-21-1333 located in Ward 4 of the City of Jackson; and

WHEREAS, the Community Improvement Division of the Planning and Development Department maintains a list of licensed, bonded, and insured contractors that received and responded to the request for bids for the project located at 306 Ford Ave.; and

WHEREAS, Quality Landscape and Lawn Maintenance Inc. submitted the lowest bid of \$1,247.00; and

WHEREAS, a municipal contract for the professional services of a contractor is not subject to advertising and bidding requirements set forth in Section 31-7-13 of the Mississippi Code of 1972; and

WHEREAS, upon receipt of a written Notice to Proceed, Quality Landscape and Lawn Maintenance Inc. through its representative, Quinton Kelly, has agreed to board up and secure structure(s) and/or cut grass, weeds, shrubbery, fence line, bushes, and saplings; remove trash, debris, tires, fallen tree parts, wooden boards, crates, appliances, old furniture, building materials, old bricks and clean curbside; and remedy conditions constituting a menace to public health, safety, and welfare for the parcel located at 306 Ford Ave. in an amount not to exceed \$1,247.00; and

WHEREAS, Quality Landscape and Lawn Maintenance Inc. has a principal office located at 133 Park Circle, Jackson, MS 39212, according to the information appearing on the Mississippi Secretary of State's website.

IT IS, THEREFORE, ORDERED that the Mayor is authorized to execute a contract with Quality Landscape & Lawn Maintenance Inc., upon receipt of a written Notice to Proceed, to cut vegetation and remedy conditions on the property located at 306 Ford Avenue deemed to be a menace to public health, safety, and welfare.

IT IS FURTHER HEREBY ORDERED that a sum not to exceed \$1,247.00 shall be paid to Quality Landscape and Lawn Maintenance upon the completion of the services provided from funds budgeted for the Division.

Vice President Lee moved adoption; **Council Member Lindsay** seconded.

Yeas – Banks, Foote, Grizzell, Hartley, Lee and Lindsay.
Nays – None.
Absent – Stokes.

There came on for consideration Agenda Item No. 8:

ORDER APPROVING CLAIMS NUMBER 28732 to 28745 APPEARING AT PAGES 394 TO 400 INCLUSIVE THEREON, ON MUNICIPAL "DOCKET OF CLAIMS", IN THE AMOUNT OF \$3,590,283.99 AND MAKING APPROPRIATIONS FOR THE PAYMENT THEREOF. President Foote stated said item would be taken up in Executive Session.

ORDER APPROVING GROSS PAYROLL INCLUDING PAYROLL DEDUCTION CLAIMS NUMBERED 28732 TO 28745 AND MAKING APPROPRIATION FOR THE PAYMENT THEREOF.

IT IS HEREBY ORDERED that payroll deduction claims numbered 28732 to 28745 inclusive therein, in the Municipal "Docket of Claims", in the aggregate amount of \$97,109.37 plus payroll, are approved for payment and necessary amounts are appropriated from various municipal funds for transfer to the payroll fund for the immediate payment thereof.

IT IS FINALLY ORDERED that the following expenditures from the accounts payable fund be made in order to pay amounts transferred thereto from the payroll fund for payment of the payroll deduction claims authorized herein for payment:

FROM:	TO ACCOUNTS PAYABLE FUND	TO PAYROLL FUND
GENERAL FUND		2,269,483.16
PARKS & RECR FUND		102,077.39
LANDFILL FUND		18,418.22
SENIOR AIDES		3,440.23
WATER/SEWER OPER & MAINT		186,238.52
PAYROLL	97,109.37	
HOUSING COMM DEV		8,506.36
TITLE III AGING PROGRAMS		5,974.20
TRANSPORTATION FUND		18,213.44
PEG ACCESS-PROGRAMMING FUND		5,465.01
2020 SAKI GRAND DOJ		7,405.71
ZOOLOGICAL PARK		28,745.96
AMERICAN RESCUE PLAN ACT 2021		10,427.45
NLC-MUNICIPAL REIMAGINING COMM		3,627.77
TOTAL		\$2,668,023.42

Vice President Lee moved adoption; **Council Member Hartley** seconded.

Yeas – Banks, Foote, Grizzell, Hartley, Lee and Lindsay.

Nays – None.

Absent – Stokes.

* * * * *

RESOLUTION OF THE CITY OF JACKSON, MISSISSIPPI, ADOPTING THE PUBLIC EMPLOYEE’S RETIREMENT SYSTEM OF MISSISSIPPI’S PROPOSED MILLAGE TAX TO SUPPORT THE COST-OF-LIVING ADJUSTMENT UNDER THE MUNICIAPL RETIREMENT SYSTEM.

WHEREAS, the City of Jackson, Mississippi, participates in the Mississippi Municipal Retirement System and maintains a fund known as the “City Employee Retirement Fund, which is for the benefit of certain city employees: and

WHEREAS, under the City of Jackson’s retirement plan, retired participants and beneficiaries currently receiving benefits receive a cost-of-living increase, which is funded through taxes levied on assessed properties; and

WHEREAS, the Board of Trustees for the Public Employee’s Retirement System of Mississippi (PERS) will provide the City of Jackson with the cost-of-living increases that is authorized by Section 21-29-247(2) and (3) of the Mississippi Code Annotated, as amended, to the persons authorized and entitled to receive them, after the following conditions are met:

- (a) the governing authority of any municipality must adopt a resolution to provide for the cost-of-living increases, and transmit the resolution to the Board of Trustees; and
- (b) the advisory board on the disability and relief fund must adopt a resolution supporting the providing of the cost-of-living increase and transmit the resolution to the Board of Trustees and
- (c) the Board of Trustees must receive the resolutions from the governing authorities and the advisory board and receive the most recent actuarial study of the disability and relief fund and the certified statement from the actuarial firm that the disability and relief fund will remain actuarially sound if the cost-of-living increases are provided; and

WHEREAS, according to the PERS Report of the Annual Valuation Covering the Participation of the City of Jackson in the Mississippi Municipal Retirement Systems prepared as of June 30, 2022, the millage rate is established at a level that will ensure actuarial soundness of the system; and

WHEREAS, according to the valuation report, the City of Jackson’s current millage rate for fiscal year ending September 30, 2023, is less than the certified rate for the fiscal year ending September 30, 2024, under the funding policy; and

WHEREAS, the City of Jackson is required to increase its current millage rate to the certified millage rate for fiscal year ending September 30, 2024, which is 3.15; and

WHEREAS, the governing authorities for the City of Jackson, Mississippi, adopt the certified millage rate of 3.15 for assessed property and authorizes the Department of the Municipal Clerk to provide this resolution to the Board of Trustees for the Public Employee’s Retirement System of Mississippi.

NOW, THEREFORE, BE IT RESOLVED BY THE GOVERNING AUTHORITIES OF THE CITY OF JACKSON, MISSISSIPPI, that the City will establish a millage rate of no less than 3.15 mills, consistent with that certified by the PERS Actuarial Valuation for Fiscal Year 2024 beginning October 1, 2023, and that the Board of Trustees of the Public Employees’ Retirement System of Mississippi is hereby directed to pay all of those persons receiving an allowance from said fund.

Vice President Lee moved adoption; **Council Member Hartley** seconded.

President Foote recognized **Fidelis Malembeka, Chief Financial Officer**, who provided a brief overview of said item.

Thereafter, **President Foote**, called for a vote of said item:

Yeas – Banks, Foote, Grizzell, Hartley, Lee and Lindsay.
Nays – None.
Absent – Stokes.

ORDER AUTHORIZING THE MAYOR TO EXECUTE A SERVICE AGREEMENT BY AND BETWEEN BUSINESS SYSTEMS & CONSULTANTS, INC. AND THE CITY OF JACKSON, MISSISSIPPI FOR DOCUMENT SCANNING SERVICES FOR THE DEPARTMENT OF MUNICIPAL CLERK-RECORDS MANAGEMENT FACILITY.

WHEREAS, the Municipal Clerk solicited quotes from two (2) to provide digital conversion of paper documents to electronic records for the City of Jackson; and

WHEREAS, the Municipal Clerk requested quotes for scanning services of approximately 400,000 documents, which includes picking up the boxes of documents, scanning images, document preparation, and shredding of documents after scanning; and

WHEREAS, Business Systems & Consultants, Inc., and Vital Records Control submitted quotes for the above-referenced services; and

WHEREAS, Business Systems & Consultants, Inc. submitted to lowest and best quote; and

WHEREAS, Business Systems & Consultant, Inc. proposed the following fee schedule for the solicited services, as follows:

- a. Capture Services – Black & White – Legal size and smaller - \$.06/image (Scan, Publish to flash drive)
- b. Document Preparation- \$22.00/hour (Preparing documents for scanning, staple removal, and removal of fasteners)
- c. Pick-up boxes- \$1,535.00

Estimated Pricing
Approximately 400,000 x \$.06/image = \$24,000.00
Approximately 730 hours of document preparation @ \$22/hour = \$16,060
Total = \$40,060.00

WHEREAS, Business Systems & Consultants, Inc. will remove documents from folders or binders, remove staples, insert document separator sheets, verify all documents are facing upwards in one direction, visually check image quality on a PC monitor, check for skewed pages, light or dark images, missed documents breaks, rescan documents as needed, provide storage of hardcopy records up to sixty (60) days and provide shredding of documents; and

WHEREAS, the Department of Municipal Records recommends that governing authorities for the City of Jackson authorize the Mayor to execute a 24-month agreement with Business Systems & Consultants, Inc. in an amount not to exceed \$40,060.00, a copy of which is attached to this Order and made a part of these minutes.

IT IS, THEREFORE, ORDERED that the Mayor is hereby authorized to execute a service agreement with Business Systems & Consultants, Inc. for the digital conversion of paper documents stored within the Records Management Facility located at 2525 Robinson Road for a 24-month term commencing on May 1, 2023, through April 30, 2025, with an option to renew at no cost to the City of Jackson.

SERVICE AGREEMENT

This Service Agreement is made by and between the City of Jackson, Mississippi, Department of Municipal Clerk, located at 219 South President Street, Jackson, MS 39201, and Business Systems, Inc., with its principal office at 405 Briarwood Drive, Suite 102 B, Jackson, MS 39206.

WHEREAS, the City of Jackson, Mississippi, through the Department of the Municipal Clerk, desires to retain and employ Business Systems and Consultants, Inc. to conduct document scanning services; and

WHEREAS, the governing authorities for the City of Jackson authorized payment to Business Systems and Consultants in an amount not to exceed \$40,060.00; and

WHEREAS, the parties intend to commit to terms and provisions that shall govern their relationship and the use of monies appropriated.

NOW, THEREFORE, in consideration of the mutual covenants and promises hereinafter set forth, and in exchange for the other good and valuable consideration, the receipt and sufficiency of all of which hereby acknowledged, the City of Jackson and Business Systems and Consultants, Inc. agree as follows:

1. **TERM:** This contract will be for 24 months, beginning May 1, 2023, and ending April 30, 2025.
2. **SCOPE OF SERVICES:** Business Systems & Consultants, Inc will provide the following services:
 - a. Business Systems & Consultants, Inc. will arrive at Storage Facility at 2525 Robinson Road, Jackson, to pick up boxes.
 - b. Business Systems & Consultants, Inc. will label and write up range descriptions on the outside of each cart.
 - c. Business Systems & Consultants, Inc. shall provide document preparation for document scanning of files for records stored at the Records Management facility located at 2525 Robinson Road as follows:
 - Remove documents from folders or binders.
 - Remove staples and make minor repairs to documents (i.e. taping, unfolding) may incur additional charges.
 - Insert document separator sheets.
 - Securely tape pages smaller than a half sheet may incur additional charges.
 - Verify all documents are facing upwards in one direction.
 - Scan documents in the same order as they were received from the customer.
 - Visually check image quality on a PC monitor, checking for skewed pages, light or dark images, and missed document breaks.
 - Rescan documents as needed to improve image quality.

- d. A final check of 10% of the documents to verify accuracy of document breaks, quality of images, and image to index.
 - e. Rescans to improve image quality may occur in any of the above steps.
 - f. Business Systems & Consultants will scan everything at the main office at 113 Little Valley Court, Birmingham, AL 35244.
 - g. Business Systems & Consultants, Inc. shall provide storage of hardcopy records within a secure facility for up to 60 days at no charge.
 - h. Business Systems & Consultants, Inc. shall shred documents after the customer has reviewed for accuracy up to sixty (60) days.
3. FEES. The City of Jackson agrees to compensate Business Systems & Consultants, Inc. to perform the Scope of Services for the following fees:
- a. Capture Services – Black & White – Legal size and smaller - \$.06/image (Scan, Publish to flash drive)
 - b. Document Preparation- \$22.00/hour (Preparing documents for scanning, staple removal, and removal of fasteners)
 - c. Pick up boxes- \$1,535.00
4. TERMINATION: If the parties wish to cancel this Agreement prior to the expiration of the contract term and for any other reason(s) than for the cause as delineated below, thirty (30) days written notice shall be provided to the other party.
5. TERMINATION BY THE CITY OF JACKSON FOR CAUSE: The City of Jackson shall have the right to immediately cancel and terminate this Agreement in its entirety if Business Systems & Consultants, Inc. defaults in the performance of, or otherwise fails or neglects to perform or observe, any of the terms, provisions, conditions, obligations, or covenants under this Agreement.
6. INDEMNIFICATION: Business Systems & Consultants, Inc. agrees to indemnify and save harmless the City, its officers, and employees from any act of or omission of the Agency, its employees, agency or servants, that results in the bodily injury, property damage, death of any party, or any other claims for damages growing out of the performance of this Service Agreement.
7. GOVERNING LAW: The parties agree that the provisions of this Agreement shall be construed according to the laws of the State of Mississippi. The parties agree that the City may assert any and all remedies available at law and or in equity in the event of default or breach and shall not be waived.
8. RENEWAL: The parties agree this Service Agreement will renew automatically, at no additional cost to the City of Jackson, if the City does not provide Business Systems & Consultants, Inc. with thirty (30) day notice that it intends to terminate the said Agreement

before the expiration of the term.

9. SEVERABILITY: It is understood and agreed by the parties hereto that if any part, term or provision of this Agreement is by the courts or other judicial body held to be illegal or in conflict with any law of the State of Mississippi or Ordinance of the City of Jackson, the validity of the remaining portions or provisions shall not be affected and the obligations of the parties shall be construed in full force as if the Agreement did not contain that particular part, term, or provision held to be invalid.
10. PUBLIC RECORDS: This Agreement, including any accompanying exhibits, attachments, and appendices, is subject to the "Mississippi Public Records Act of 1983" and its exceptions. See Mississippi Code Annotated §§ 25-61-1 et seq. and Mississippi Code Annotated § 79-23-1.
11. MODIFICATION OR AMENDMENT: Modifications or amendments to this Agreement may be made upon mutual Agreement of the parties, in writing, signed by the parties hereto and approved as required by the City Council and Mayor.
12. APPROVAL: It is understood that this Agreement requires approval by the Governing Authority/City Council, and if the Governing Authority/City Council does not approve this Agreement, it is void, and no payment shall be made hereunder.
13. AVAILABILITY OF FUNDS: The parties agree that the City's obligations under this Agreement are subject to the continued availability of funding and contingent upon the City receiving sufficient revenues during the budget year to provide the allocated monies.

IN WITNESS THEREOF, this Agreement is executed by the parties hereto on this the _____ day of _____, 2023.

CITY OF JACKSON, MISSISSIPPI

BY: _____
Chokwe Antar Lumumba, Mayor

ATTEST

City Clerk

BUSINESS SYSTEMS & CONSULTANTS, INC.

BY: _____
Barry McNair, Business Development
Manager

Council Member Hartley moved adoption; Council Member Lindsay seconded.

Yeas – Banks, Foote, Grizzell, Hartley, Lee and Lindsay.
Nays – None.
Absent – Stokes.

* * * * *

ORDER REVISING THE 2022-2023 FISCAL YEAR BUDGET FOR THE DEPARTMENT OF HUMAN AND CULTURAL SERVICES.

WHEREAS, the City of Jackson, Department of Human and Cultural Services requests a revision to its 2022-2023 fiscal budget to provide consistent and outstanding service to our employees and citizens; and

WHEREAS, the Department of Human and Cultural Services recommends that the governing authorities for the City of Jackson transfer funds in the amount of \$90,000.00, to provide services and maintain needed repairs throughout the department and support the City of Jackson Summer Film Camp; and

WHEREAS, Section 21-35-25 of the Mississippi Code Annotated, as amended, states that if it affirmatively appears at any time during the current fiscal year that there is in any fund or account any sum remaining unexpended and not needed or expected to be needed for the purpose or purposes for which appropriated in said budget, then the governing authorities may, in their discretion, transfer such sum or any part thereof to any other fund or funds or account or accounts where needed, by order to such effect entered upon their minutes. This shall not, however, authorize the expenditure of any funds for any purpose other than that for which the levy producing such funds was made; and

WHEREAS, the Department of Human and Cultural Services represents that funds from Sundry-Contingencies will not be expended because Hinds County Human Resource Agency no longer requires the funds; therefore, these funds are not needed for that purpose; and

WHEREAS, the Department of Human and Cultural Services Fiscal Year 2022-2023 recommends its budget be revised, as follows:

FUNDS TRANSFER FROM:	FUNDS TRANSFER TO:
Sundry-Contingencies 001 43300 6739 \$15,000	ECD Security 001-43300-6419 \$15,000
Sundry-Contingencies 001 43300 6739 \$15,000	Senior Center Repairs (Sykes) 001-43420 6317 \$15,000
Sundry-Contingencies 001 43300 6739 \$24,000	Mary C Jones 001-43300-6317 \$24,000
Sundry-Contingencies 001 43300 6739 \$26,000	Smith Robertson Museum 001 43600 6848 \$26,000
Sundry-Contingencies 001 43300 6739 \$10,000	Film Camp 300-44346-6299 \$10,000
TOTAL \$90,000	TOTAL \$90,000

WHEREAS, this intradepartmental transfer of Ninety Thousand Dollars (\$90,000.00) is in statutory compliance with Section 21-35-25 of the Mississippi Code Annotated, as amended, as there have been no other budget amendments or revisions to the Fiscal Year 2022-2023 Budget for the Department of Human and Cultural Services and this transfer does not exceed ten percent (10%) of the total budget amount appropriated to the Department of Human and Cultural Services in the Fiscal Year 2022-2023 Budget.

IT IS, THEREFORE, ORDERED that the Department of Human and Cultural Services Fiscal Year 2022-2023 budget be revised as set forth above.

Council Member Lindsay moved adoption; Vice President Lee seconded.

President Foote recognized Louis Wright, Chief Administrative Officer, who provided a brief overview of said item.

Thereafter, President Foote, called for a vote of said item:

Yeas – Banks, Foote, Grizzell, Hartley, Lee and Lindsay.
Nays – None.
Absent – Stokes.

ORDER AUTHORIZING THE MAYOR TO EXECUTE AN ANTENNA SITE LICENSE AGREEMENT WITH T-MOBILE SOUTH, LLC TO MODIFY EQUIPMENT AND INCREASE LICENSEE FEES AT TWO TOWER SITES WITHIN THE CITY OF JACKSON.

WHEREAS, Mississippi Code of 1972, Annotated, Section 21-17-5(1) vests the care, management, and control of the municipal affairs and its property and finances with the governing authorities; and

WHEREAS, Mississippi Code of 1972, Annotated, Section 21-17-5(1) authorizes the governing authorities of the municipality to adopt an order concerning municipal affairs, property and finances with are not inconsistent with the Mississippi Constitution of 1890, the Mississippi Code of 1972, or any other statute or law of the State of Mississippi; and

WHEREAS, the Department of Information Technology, through the Telecommunications Division, needs to amend the Antenna Site License Agreements with T-Mobile South, LLC that will modify T-Mobile’s equipment and increase the monthly license fees at two (2) towers, at Site 28/TCS, located at 2835 Oak Forest and Site 3/ FS 3 Tower, located at 333 East Fortification Street; and

WHEREAS, T-Mobile, with its principal office located at T-Mobile USA Incorporation, 12920 SE 38th Street Bellevue, WA 98006, has proposed the following provisions for the tower located at 333 East Fortification Street:

- a) At the commencement of the first (1st) renewal term provided for by this fourth amendment, licensee shall pay licensor annual rent in the amount of Fifty-three Thousand Eight Hundred Twenty- nine and 05/100th Dollars (\$53,829.05) per year (the “rent”), partial years to be prorated. Where duplicate rent would occur, a credit shall be taken by licensee for any prepayment of rent by licensee.
- b) Rent shall be adjusted annually on each anniversary of the First Renewal Term or any Additional Renewal Term by an amount equal to three and one-half percent (3.5%) over the Rent for the immediately preceding year. This new Rent and Rent adjustment shall supersede and replace any prior Rent or Rent adjustments.
- c) T-Mobile South, LLC may terminate the Agreement without further liability, upon thirty (30) days prior written notice to the City of Jackson ninety (90) days written notice for any or no reason.

WHEREAS, T-Mobile, with its principal office located at T-Mobile USA Incorporation, 12920 SE 38th Street Bellevue, WA 98006, has proposed the following provisions for the tower located at 2835 Oak Forest:

- a) At the commencement of the first (1st) renewal term provided for by this fourth amendment, T-Mobile South, LLC shall pay the City of Jackson annual rent in the amount of Thirty-nine Thousand Three- Hundred Eighty-Two and 28/100th Dollars (\$39,382.28) per year (the “rent”), partial years to be prorated. Where duplicate rent would occur, a credit shall be taken by licensee for any prepayment of rent by licensee.
- b) Rent shall be adjusted annually on each anniversary of the First Renewal Term or any Additional Renewal Term by an amount equal to three and one-half percent (3.5%) over the Rent for the immediately preceding year. This new Rent and Rent adjustment shall supersede and replace any prior Rent or Rent adjustments.

-
-
- c) T-Mobile South, LLC may terminate the Agreement without further liability, upon thirty (30) days prior written notice to the City of Jackson ninety (90) days written notice for any or no reason.

IT IS, THEREFORE, ORDERED that the Mayor shall be authorized to execute the Fourth Amendment to commencement Agreement for the property at Site 3/FS 3 Tower, located at 333 Fortification Street, Jackson, Hinds County, Mississippi, 39202.

IT IS, THEREFORE, ORDERED that the Mayor shall be authorized to execute the reinstatement and Fourth Amendment to Antenna Site License Agreement for the property at the TCS, located at Site 28/2835 Oak Forest Drive, Jackson, Hinds County, Mississippi, 39212.

IT IS FURTHER ORDERED that the Mayor may perform those actions necessary to effect the purpose of this Order with the exception of expending municipal funds without further approval of the Jackson City Order.

Vice President Lee moved adoption; **Council Member Lindsay** seconded.

Yeas – Banks, Foote, Grizzell, Hartley, Lee and Lindsay.

Nays – None.

Absent – Stokes.

* * * * *

ORDER AMENDING THE FISCAL YEAR 2023 BUDGET OF THE CITY OF JACKSON DEPARTMENT OF PUBLIC WORKS.

WHEREAS, since the adoption of the Fiscal Year 2023 City of Jackson budget for the Department of Public Works, the department is faced with unanticipated needs that will require a reallocation of funding; and

WHEREAS, the Department of Public Works recommends that the governing authorities for the City of Jackson amend the Fiscal Year 2023 City of Jackson budget to provide funding for these unanticipated needs; and

WHEREAS, if it affirmatively appears at any time during the current fiscal year that there is in any fund or account any sum remaining unexpended and not needed or expected to be needed for the purpose or purposes for which appropriated in said budget, then the governing authorities may, in their discretion, transfer such sum or any part thereof to any other fund or funds or account or accounts where needed, by order to such effect entered upon their minutes. This shall not, however, authorize the expenditure of any funds for any purpose other than that for which the levy producing such funds was made. Miss. Code. Ann. §21-35-25 (West); and

WHEREAS, the proposed changes in Fund 1 are necessary to reallocate funds from a vacant Deputy Director's position to upgrade the 5th-floor conference room's computer and conferencing equipment, replace well-outdated computers in the Engineering Office and Fiscal Office, and set aside funds for replacing signs for the renaming of Bobby Rush Boulevard and James Meredith Drive; and

WHEREAS, the proposed changes in Fund 173 and Fund 372 are necessary to move funds intended for capitalized expenditures into the newer 6800 object codes for capitalized expenditures; and

WHEREAS, the proposed changes to Fund 31 Water Sewer Engineering are necessary to move funds from an unfilled position to pay for temp work performed last summer and fall and for ongoing uniform expenses budgeted in the water half of this division; and

WHEREAS, the proposed change in Fund 174 would move funds from data processing to other professional services to fully fund the CSL flow meter contract recently approved by the City Council; and

**REGULAR MEETING OF THE CITY COUNCIL
TUESDAY, APRIL 25, 2023 10:00 A.M.**

WHEREAS, any amendments made pursuant to this section to an originally adopted budget which exceed ten percent (10%) of the total amount appropriated or authorized to be expended in a particular department fund shall be published or posted within two (2) weeks of the action in a newspaper in the same manner as the final adopted budget. Separate amendments to an originally adopted budget during one fiscal year which affect a particular department fund shall be considered as one (1) amendment in determining whether the ten percent (10%) threshold requiring publication or posting has been reached. This publication or posted notice shall contain a description of the amendment, the amount of money and funds affected, and a detailed statement explaining the need and purpose of the amendment. The vote of each member of the municipality's governing authority on each amendment shall be included in the publication or posted notice. Miss. Code. Ann. §21-35-25 (West); and

WHEREAS, the Department of Public Works recommends that the governing authorities amend the following accounts, as follows:

From: Account	Amount	To: Account
173 45135 6413	\$ 405,936.00	173 45135 6823
173 45190 6413	\$ 99,863.00	173 45190 6823
173 52290 6413	\$ 954,045.00	173 52290 6823
173 45135 6485	\$ 2,021,580.00	173 45135 6824
173 45190 6485	\$ 3,240,609.00	173 45190 6824
173 52290 6485	\$ 855,264.00	173 52290 6824
372 52290 6419	\$ 132,639.00	372 52290 6823
031 52210 6111	\$ 22,480.00	031 52210 6489
031 52210 6111	\$ 3,000.00	031 52210 6489
031 52210 6111	\$ 2,247.00	031 52210 6489
031 52210 6111	\$ 8,000.00	031 52210 6489
031 52210 6111	\$ 2,088.00	031 52210 6489
031 52210 6111	\$ 1,850.00	031 52120 6516
001 46110 6111	\$ 20,000.00	001 44830 6240
001 46110 6111	\$ 11,080.00	001 46110 6240
001 46110 6111	\$ 3,122.00	001 45010 6240
001 46110 6131	\$ 1,877.00	001 45010 6240
001 46110 6136	\$ 468.00	001 45010 6240
001 46110 6133	\$ 5,613.00	001 45010 6240
174 94400 6847	\$ 40,000.00	174 94400 6419

Total: 7,831,761.00

NOW, IT IS THEREFORE ORDERED that the Department of Public Works Fiscal Year 2022-2023 budget be revised as follows:

From: Account	Amount	To: Account
173 45135 6413	\$ 405,936.00	173 45135 6823
173 45190 6413	\$ 99,863.00	173 45190 6823
173 52290 6413	\$ 954,045.00	173 52290 6823
173 45135 6485	\$ 2,021,580.00	173 45135 6824
173 45190 6485	\$ 3,240,609.00	173 45190 6824
173 52290 6485	\$ 855,264.00	173 52290 6824
372 52290 6419	\$ 132,639.00	372 52290 6823
03152210 6111	\$ 22,480.00	031 52210 6489
03152210 6111	\$ 3,000.00	031 52210 6489
03152210 6111	\$ 2,247.00	031 52210 6489
03152210 6111	\$ 8,000.00	031 52210 6489

**REGULAR MEETING OF THE CITY COUNCIL
TUESDAY, APRIL 25, 2023 10:00 A.M.**

031 52210 6111	\$ 2,088.00	031 52210 6489
031 52210 6111	\$ 1,850.00	031 52120 6516
001 46110 6111	\$ 20,000.00	001 44830 6240
001 46110 6111	\$ 11,080.00	001 46110 6240
001 46110 6111	\$ 3,122.00	001 45010 6240
001 46110 6131	\$ 1,877.00	001 45010 6240
001 46110 6136	\$ 468.00	001 45010 6240
001 46110 6133	\$ 5,613.00	001 45010 6240
174 94400 6847	\$ 40,000.00	174 94400 6419

Total: 7,831,761.00

IT IS, THEREFORE, FURTHER ORDERED pursuant to Miss. Code Ann. Section 2135-25, this budget revision shall be published or posted within two (2) weeks of approval, in a newspaper in the same manner as the final adopted budget. In accordance with Miss. Code Ann. Section 21-35-25, the published notice shall contain a description of the amendment, the amount of money and funds affected, and a detailed statement explaining the need and purpose of the amendment, as well as, the vote of each City Council member.

Council Member Banks moved adoption; **Council Member Lindsay** seconded.

President Foote recognized **Terry Williamson, Legal Counsel**, who stated that an amendment was needed in said order. The order needed to be amended in the last WHEREAS and the NOW, IT IS THEREFORE ORDERED Sections changing account number “00144830 6240” to “00144830 6419”.

President Foote recognized **Council Member Banks** who moved; seconded by **Council Member Grizzell**, to amend said order to reflect the changes as stated by **Terry Williamson, Legal Counsel**. The motion prevailed by the following vote:

Yeas – Banks, Foote, Grizzell, Hartley, Lee and Lindsay.
Nays – None.
Absent – Stokes.

Thereafter, **President Foote** called for a vote on said Order as amended:

ORDER AMENDING THE FISCAL YEAR 2023 BUDGET OF THE CITY OF JACKSON DEPARTMENT OF PUBLIC WORKS.

WHEREAS, since the adoption of the Fiscal Year 2023 City of Jackson budget for the Department of Public Works, the department is faced with unanticipated needs that will require a reallocation of funding; and

WHEREAS, the Department of Public Works recommends that the governing authorities for the City of Jackson amend the Fiscal Year 2023 City of Jackson budget to provide funding for these unanticipated needs; and

WHEREAS, if it affirmatively appears at any time during the current fiscal year that there is in any fund or account any sum remaining unexpended and not needed or expected to be needed for the purpose or purposes for which appropriated in said budget, then the governing authorities may, in their discretion, transfer such sum or any part thereof to any other fund or funds or account or accounts where needed, by order to such effect entered upon their minutes. This shall not, however, authorize the expenditure of any funds for any purpose other than that for which the levy producing such funds was made. Miss. Code. Ann. §21-35-25 (West); and

WHEREAS, the proposed changes in Fund 1 are necessary to reallocate funds from a vacant Deputy Director's position to upgrade the 5th-floor conference room's computer and

**REGULAR MEETING OF THE CITY COUNCIL
TUESDAY, APRIL 25, 2023 10:00 A.M.**

conferencing equipment, replace well-outdated computers in the Engineering Office and Fiscal Office, and set aside funds for replacing signs for the renaming of Bobby Rush Boulevard and James Meredith Drive; and

WHEREAS, the proposed changes in Fund 173 and Fund 372 are necessary to move funds intended for capitalized expenditures into the newer 6800 object codes for capitalized expenditures; and

WHEREAS, the proposed changes to Fund 31 Water Sewer Engineering are necessary to move funds from an unfilled position to pay for temp work performed last summer and fall and for ongoing uniform expenses budgeted in the water half of this division; and

WHEREAS, the proposed change in Fund 174 would move funds from data processing to other professional services to fully fund the CSL flow meter contract recently approved by the City Council; and

WHEREAS, any amendments made pursuant to this section to an originally adopted budget which exceed ten percent (10%) of the total amount appropriated or authorized to be expended in a particular department fund shall be published or posted within two (2) weeks of the action in a newspaper in the same manner as the final adopted budget. Separate amendments to an originally adopted budget during one fiscal year which affect a particular department fund shall be considered as one (1) amendment in determining whether the ten percent (10%) threshold requiring publication or posting has been reached. This publication or posted notice shall contain a description of the amendment, the amount of money and funds affected, and a detailed statement explaining the need and purpose of the amendment. The vote of each member of the municipality's governing authority on each amendment shall be included in the publication or posted notice. Miss. Code. Ann. §21-35-25 (West); and

WHEREAS, the Department of Public Works recommends that the governing authorities amend the following accounts, as follows:

From: Account	Amount	To: Account
173 45135 6413	\$ 405,936.00	173 45135 6823
173 45190 6413	\$ 99,863.00	173 45190 6823
173 52290 6413	\$ 954,045.00	173 52290 6823
173 45135 6485	\$ 2,021,580.00	173 45135 6824
173 45190 6485	\$ 3,240,609.00	173 45190 6824
173 52290 6485	\$ 855,264.00	173 52290 6824
372 52290 6419	\$ 132,639.00	372 52290 6823
031 52210 6111	\$ 22,480.00	031 52210 6489
031 52210 6111	\$ 3,000.00	031 52210 6489
031 52210 6111	\$ 2,247.00	031 52210 6489
031 52210 6111	\$ 8,000.00	031 52210 6489
031 52210 6111	\$ 2,088.00	031 52210 6489
031 52210 6111	\$ 1,850.00	031 52120 6516
001 46110 6111	\$ 20,000.00	001 44830 6419
001 46110 6111	\$ 11,080.00	001 46110 6240
001 46110 6111	\$ 3,122.00	001 45010 6240
001 46110 6131	\$ 1,877.00	001 45010 6240
001 46110 6136	\$ 468.00	001 45010 6240
001 46110 6133	\$ 5,613.00	001 45010 6240
174 94400 6847	\$ 40,000.00	174 94400 6419

Total: 7,831,761.00

NOW, IT IS THEREFORE ORDERED that the Department of Public Works Fiscal Year 2022-2023 budget be revised as follows:

**REGULAR MEETING OF THE CITY COUNCIL
TUESDAY, APRIL 25, 2023 10:00 A.M.**

From: Account	Amount	To: Account
173 45135 6413	\$ 405,936.00	173 45135 6823
173 45190 6413	\$ 99,863.00	173 45190 6823
173 52290 6413	\$ 954,045.00	173 52290 6823
173 45135 6485	\$ 2,021,580.00	173 45135 6824
173 45190 6485	\$ 3,240,609.00	173 45190 6824
173 52290 6485	\$ 855,264.00	173 52290 6824
372 52290 6419	\$ 132,639.00	372 52290 6823
031 52210 6111	\$ 22,480.00	031 52210 6489
031 52210 6111	\$ 3,000.00	031 52210 6489
031 52210 6111	\$ 2,247.00	031 52210 6489
031 52210 6111	\$ 8,000.00	031 52210 6489
031 52210 6111	\$ 2,088.00	031 52210 6489
031 52210 6111	\$ 1,850.00	031 52120 6516
001 46110 6111	\$ 20,000.00	001 44830 6419
001 46110 6111	\$ 11,080.00	001 46110 6240
001 46110 6111	\$ 3,122.00	001 45010 6240
001 46110 6131	\$ 1,877.00	001 45010 6240
001 46110 6136	\$ 468.00	001 45010 6240
001 46110 6133	\$ 5,613.00	001 45010 6240
174 94400 6847	\$ 40,000.00	174 94400 6419

Total: 7,831,761.00

IT IS, THEREFORE, FURTHER ORDERED pursuant to Miss. Code Ann. Section 21-35-25, this budget revision shall be published or posted within two (2) weeks of approval, in a newspaper in the same manner as the final adopted budget. In accordance with Miss. Code Ann. Section 21-35-25, the published notice shall contain a description of the amendment, the amount of money and funds affected, and a detailed statement explaining the need and purpose of the amendment, as well as, the vote of each City Council member.

Yeas – Banks, Foote, Grizzell, Hartley, Lee and Lindsay.

Nays – None.

Absent – Stokes.

* * * * *

ORDER RATIFYING CONTRACTS RELATED TO THE EMERGENCY REPAIRS TO THALIA MARA HALL AND THE ARTS CENTER OF MISSISSIPPI IN PREPARATION FOR THE U.S.A. INTERNATIONAL BALLET COMPETITION.

WHEREAS, the City of Jackson Department of Public Works and Department of Human and Cultural Services are currently in the process of preparing Thalia Mara Hall and the Arts Center of Mississippi for the USA International Ballet Competition (“USA IBC”); and

WHEREAS, the USA IBC is a two-week Olympic-style competition for top young dancers from all over the world, which occurs every four (4) years in the City of Jackson and is scheduled to take place June 10, 2023 through June 24, 2023; and

WHEREAS, the 2018 USA IBC was attended by more than 44,000 people generating a combined economic impact of \$12.5 million for the City of Jackson and the State of Mississippi; and

WHEREAS, the USA IBC is scheduled to begin June 10, 2023 and there are necessary repairs which must take place at both Thalia Mara and the Arts Center of Mississippi prior to June 10, 2023; and

WHEREAS, the City of Jackson previously contracted with Cooke Douglass Farr Lemons (“CDFL”) to produce a scope of work for Thalia Mara Hall; and

WHEREAS, the City has contracted Canizaro Cawthon Davis, A Professional Association to produce a scope of work for the Arts Center of Mississippi, which scope is to include an update to the existing public restrooms to bring them into compliance with the ADA due to performance issues with Construction Specialists, LLC, which recently caused the City to terminate that construction agreement; and

WHEREAS, the City has authorized a contract with Benchmark Construction Corporation, whose principal office address is 1867 Crane Ridge Drive #200A, Jackson, MS 39216, to provide general contractor services to assist the City of Jackson with completing the proposed scope of work for Thalia Mara Hall by June 1, 2023; and

WHEREAS, pursuant to Miss. Code Ann. § 31-7-13(k), due to the threat of economic loss based on the restricted time period, limitations of available equipment, materials and delivery schedules, and to protect and preserve the facilities, the City of Jackson invoked the emergency procurement procedure for the intended repairs to Thalia Mara and the Arts Center, a copy of which is attached hereto; and

WHEREAS, pursuant to the emergency procurement process, the following proposals have been accepted for work or materials, which constitute a contract for the work, a copy of said contracts being attached to this Order and made a part of the minutes of this meeting:

Vendor	Services/Materials	Amount
Global Sector Security	Access Control Work	\$ 2,798.00
West Architectural Specialities	Access Panel	\$ 595.00
Scanlon Taylor	Millwork Millwork Change Order	\$ 184.00
J.L. Roberts Mechanical, LLC	HVAC Work	\$ 94,612.00
Big John's Tree Service	Tree Trimming	\$ 6,250.00
A Complete Flag Source	Flagpoles	\$ 27,717.30
West Architectural Specialities	Signage/Fire Extg Cabinets	\$ 3,250.00
Benchmark Const. Corp.	Reimburse for Roto-Rooter	\$ 387.95
Schindler Elevator Corp.	Escalator Repairs	\$ 28,657.00
Elite Paint	Add'l Painting; Granite Cleaning	\$ 36,200.00
	Total	\$ 200,651.25

IT IS, THEREFORE, ORDERED that the contracts for work listed in the proposals listed above at the amounts stated are hereby ratify.



April 14, 2023

Catoria P. Martin
City Attorney
City of Jackson, MS
Post Office Box 2779
Jackson, MS 39207

Re: Thalia Mara – Paint, Granite Cleaning

Dear Ms. Martin:

Please find attached a proposal from Elite Paint, LLC in the amount of \$36,200.00. I have reviewed the proposal and recommend it be accepted.

Please let me know if you have any questions.

Sincerely,

David Marsh,
President

Accepted by 
City of Jackson, Mississippi

1867 Crane Ridge Dr., Suite 200-A, Jackson, MS 39216 • P.O. Box 31177 Jackson, MS 39286-1177
Phone 601-362-6110 • Fax 601-362-9812 • www.benchmarkms.com



ELITE PAINT LLC
156 Greenfield Ridge Dr.
Brandon, Ms, 39042
josef@elitepaintllc.com
Cell 601-717-2976

TO: BENCHMARK CONSTRUCTION
1867 Crane Ridge Drive Suite 200-A
Jackson, MS 39216

Estimate	Date
#029	4-14-23

Project: Thalia Mara Hall
Address: 255 E Pascagoula St.
Jackson, MS 39201

Stage fronts
Exterior stairs risers
Bridge walk-on
Granite fountain cleaner

Total Estimate \$36,200

Respectfully, Jose Fonseca



April 11, 2023

Catoria P. Martin
 City Attorney
 City of Jackson, MS
 Post Office Box 2779
 Jackson, MS 39207

REVISED

Re: Arts Center – Access Control Work

Dear Ms. Martin:

Please find attached a revised proposal from Global Sector Security in the amount of \$2,798.00. I have reviewed the proposal and recommend it be accepted.

Please let me know if you have any questions.

Sincerely,

David Marsh
 David Marsh,
 President

Accepted by: *[Signature]*
 City of Jackson, Mississippi

1867 Crane Ridge Dr., Suite 200-A, Jackson, MS 39216 • P.O. Box 31177 Jackson, MS 39286-1177
 Phone 601-362-6110 • Fax 601-362-9812 • www.benchmarkms.com



Global Sector Security LLC
 3953 Underwood Drive
 Flowood, MS 39232

Proposal

Proposal Date: 3/30/2023
 Proposal #: 41805
 Project:

Bill To:
 Thalia Mara Hall
 255 East Pascagoula Street
 Jackson, MS 39201

Description	Est. Hours/Qty.	Rate	Total
Access Control Wire Per Ft.	200	1.69	338.00T
Miscellaneous Parts and supplies	1	300.00	300.00T
Labor Hour (2 Man Team)	16	135.00	2,160.00T
Due To Condition Of Building Additional Parts may be needed			
Sales Tax		0.00%	0.00
Total			\$2,798.00



April 5, 2023

Catoria P. Martin
City Attorney
City of Jackson, MS
Post Office Box 2779
Jackson, MS 39207

Re: Arts Center – Scanlon Taylor – Millwork Change Order

Dear Ms. Martin:

Please find attached a proposal from Scanlon-Taylor in the amount of \$184.00 due to unforeseen condition. I have reviewed the proposal and recommend it be accepted.

Please let me know if you have any questions.

Sincerely,

A handwritten signature in blue ink that reads 'David Marsh'.

David Marsh,
President

Accepted by: _____

A handwritten signature in blue ink, appearing to be 'Charles L. ...', written over a horizontal line.

City of Jackson, Mississippi

SCANLON-TAYLOR MILLWORK COMPANY
MANUFACTURERS
ARCHITECTURAL WOODWORK
POST OFFICE BOX 5029
JACKSON, MS 39296-5029

Telephone: 601.362.5333
Fax: 601.981.7504

Office and Mill
2913 N. West Street
Jackson, MS 39216

MATERIAL CHANGE ORDER PRICE QUOTATION

DATE: 4/5/2023
TO: DAVID MARSH
COMPANY: BENCHMARK CONSTRUCTION CORP.
EMAIL: dmarsh@benchmarkms.com
FROM: SHERMAN DUKES
REFERENCE: ART CENTER OF MISSISSIPPI, CITY OF JACKSON – ATRIUM RAIL CAP
PAYMENT TERMS: NET 30 DAYS FROM DATE OF INVOICE – NO RETAINAGE WITHHELD
TAX: TAX EXEMPT # _____

ADD PRICE FOR INCREASING THE WIDTH OF THE PAINT GRADE POPLAR ATRIUM RAIL CAP FROM 7 1/4" PER THE ORIGINAL DETAIL (S/A331) TO 9 1/4" PER ACTUAL JOBSITE CONDITIONS.

TOTAL ADD PRICE \$ 184.00
PLUS ANY APPLICABLE TAXES

PRICE DOES NOT INCLUDE: PRIMING, PAINTING OR PREFINISHING; BLOCKING OF ANY KIND;
CHANGE TO INSTALLATION LABOR; SALES TAX

PLEASE ADVISE HOW IS WE ARE TO PROCEED.

CALL WITH ANY QUESTIONS.



April 11, 2023

Catoria P. Martin
City Attorney
City of Jackson, MS
Post Office Box 2779
Jackson, MS 39207

Re: Arts Center – HVAC Work

Dear Ms. Martin:

Please find attached a proposal from J.L. Roberts Mechanical in the amount of \$94,612.00. I have reviewed the proposal and recommend it be accepted.

Please let me know if you have any questions.

Sincerely,

David Marsh,
President

Accepted by: 
City of Jackson, Mississippi



COMPANY	BENCHMARK CONSTRUCTION CORPORATION	DATE	APRIL 06, 2023
CONTACT	DAVID MARSH	CR #	13941-MC
PROJECT	ARTS CENTER OF MISSISSIPPI - CONTROLS		

SCOPE OF WORK

AIR HANDLING UNIT CONTROLS

- Replacement of existing return air sensors in AHU-1 & 2
- Replacement of Chilled water coil control valve actuator with DDC Actuator on AHU-2
- Replacement of Re-Heat coil control valve actuators with DDC Actuators on AHU-1 & 2
- Replacement of O/A and R/A damper actuators on AHU 1 & 2
- Replacement of existing belts/pulleys on AHU 1 & 2
- Test and balance assistance for R/A and O/A split

BOILER CONTROLS RETROFIT

- Replacement of existing DDC controller
- Furnish/install new HW mixing valve
- Furnish/install temp sensors, relays and communication wiring as required
- Programming and verification of operation

NETWORKING/INTEGRATION

- Provide/install Network programming and Graphics including the following: Integration of controls installed under this scope including interface with existing JCI Metasys System.

NOTE: A meeting will be required prior to JL Roberts accepting any work order associated with this proposal.

Not Included

After hours work, Dampers, VFD's, Controls for terminal units, system re-commissioning, smoke/fire detectors, servicing/cleaning of existing equipment, chemical treatment, equipment warranties on AHU's or Boiler, Servers/workstations, software.

PRICING

BASE BID PRICE:	\$94,612.00

ACCEPTANCE

This proposal may be withdrawn by J.L. Roberts Mechanical if not accepted within 30 days. PROPOSAL ACCEPTANCE The above prices, specifications and conditions are satisfactory and are hereby accepted. J.L. Roberts Mechanical is authorized to perform the work as specified. Payment will be made as outlined in the contract documents.	David Graves <i>J.L. Roberts Mechanical Authorized Representative</i>

J.L. ROBERTS MECHANICAL LLC • P.O. Box 180579 • 150 Linda Jo Drive • Richland, MS 39218 • 601-939-1011 • Fax 601-936-3958



April 4, 2023

Catoria P. Martin
City Attorney
City of Jackson, MS
Post Office Box 2779
Jackson, MS 39207

Re: Arts Center – Access Panel

Dear Ms. Martin:

Please find attached a proposal from West Architectural Specialties in the amount of \$595.00. I have reviewed the proposal and recommend it be accepted.

Please let me know if you have any questions.

Sincerely,

David Marsh
David Marsh,
President

Accepted by: *[Signature]*
City of Jackson, Mississippi

QUOTATION

291 Highway 51, Suite E-6
Ridgeland, MS 39157
Phone: 601/853-9908



P. O. Box 1828
Ridgeland, MS 39158-1828
Fax: 601/853-9921

To: City of Jackson
C/o Benchmark Construction, David Marsh
PROJECT: Arts Center of Mississippi, Jackson, Mississippi

Date: 04.03.2023

Addenda Acknowledged: N/A

We propose to furnish for the above project materials listed below:

Access Panel: as requested by Steve Davis

1 ea. 24" w x 36" h Non-Flated wall access panel with mortise prep lock (includes cylinder)

White Powder coat finish

Requested for access underneath stair for electrical access

Cut sheet attached

Current lead time: 2 weeks

FOR THE SUM OF.....\$ 595.00

Note: Due to current fluctuations in stainless steel and aluminum prices, we are required to review all pricing after 30 days prior to accepting a purchase order for any products containing stainless steel or aluminum.

INSTALLATION AVAILABLE ON ALL MATERIALS UPON REQUEST, IF NOT SHOWN ABOVE

F.O.B. Factory, Freight allowed jobsite

MS COR# 17654-SC

Taxes: Not Included

TERMS: NET, 30 DAYS

By: M. Keith West, FCSI, CCPR **

Accepted: _____

This proposal is subject to the approval of the architect.

Prices subject to change 30 days after date, and subject to acceptance by our suppliers. All agreements contingent upon strikes, accidents, or delays unavoidable or beyond our control.

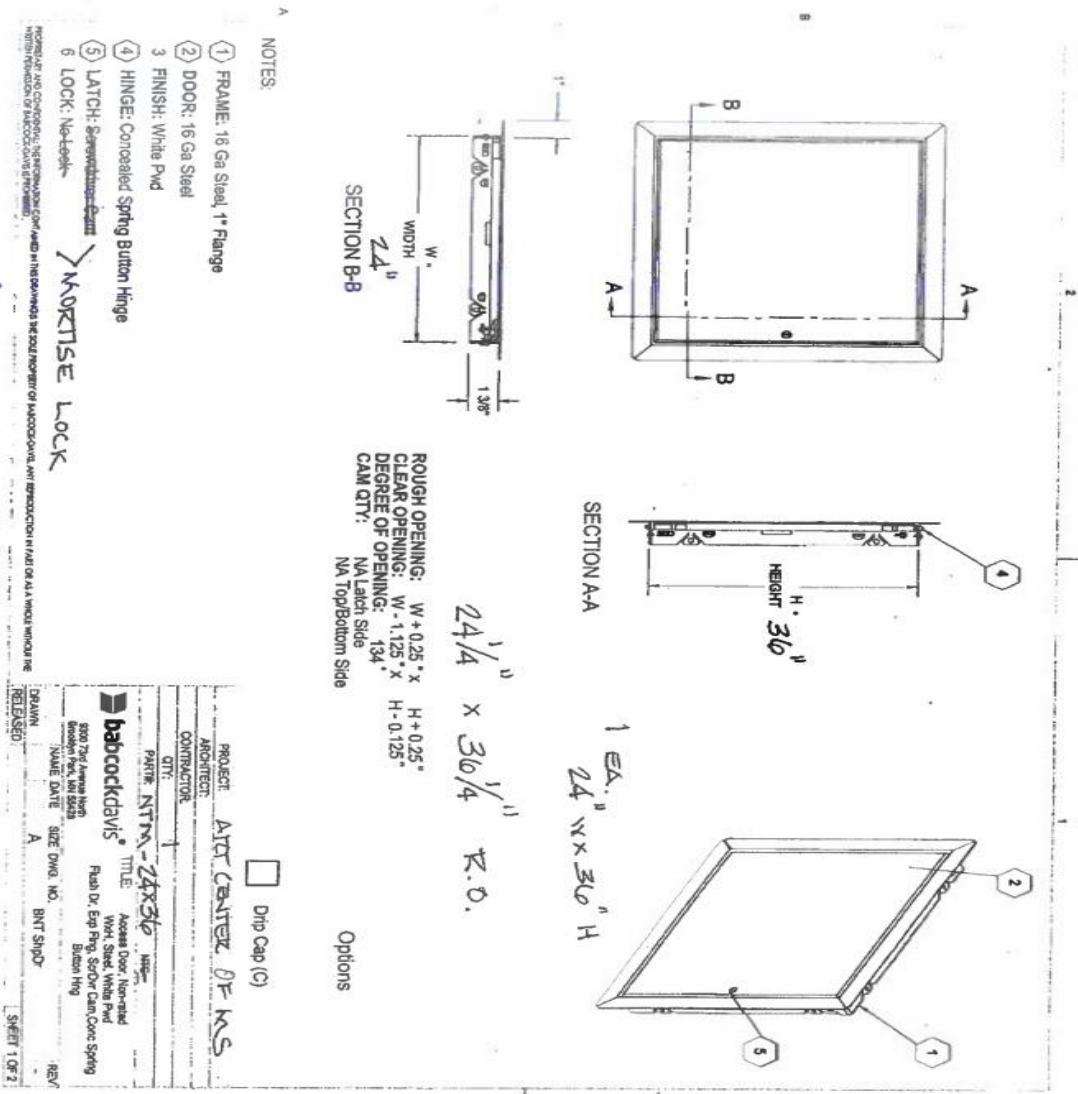



April 12, 2023

Catoria P. Martin
City Attorney
City of Jackson, MS
Post Office Box 2779
Jackson, MS 39207

Re: Arts Center – Signage/Fire Extg Cabinets

Dear Ms. Martin:

Please find attached a proposal from West Architectural Specialties in the amount of \$3,250.00. I have reviewed the proposal and recommend it be accepted.

Please let me know if you have any questions.

Sincerely,

J. David Marsh, Pres.

David Marsh,
President

Accepted by: _____

[Signature]
City of Jackson, Mississippi

1867 Crane Ridge Dr., Suite 200-A, Jackson, MS 39216 • P.O. Box 31177 Jackson, MS 39286-1177
Phone 601-362-5110 • Fax 601-362-9812 • www.benchmarkms.com

QUOTATION

291 Highway 51, Suite E-6
Ridgeland, MS 39157
Phone: 601/853-9908



P. O. Box 1828
Ridgeland, MS 39158-1828
Fax: 601/853-9921

To: City of Jackson
C/o Benchmark Construction, Attn.: David Marsh
PROJECT: Arts Center of Mississippi, Jackson, Mississippi

Date: 04.12.2023

Addenda Acknowledged: None
We propose to furnish for the above project materials listed below:
Fire Extinguisher Cabinets: as requested & as identified below
3 ea. semi-recessed non-rated steel cabinets
Full glass bubble acrylic door

FOR THE SUM OF.....\$ 600.00

Restroom Signage: as requested & as identified below
2 ea. 8" x 6" Unisex / ADA restroom signs / for renovated restrooms
1 ea. 8" x 6" Men restroom sign, no h/c symbol / for eastern existing room
1 ea. 8" x 6" Women restroom sign, no h/c symbol / eastern existing room
1 ea. 9" x 7" directional sign for eastern existing restroom / no h/c symbol
1 ea. 10" x 7" direction sign for renovated restrooms / ADA symbols
Standard color selections & production schedules

FOR THE SUM OF.....\$ 650.00

Installation of the above, including removing existing cabinets and opening modifications for new cabinets and installation of restrooms signs after final wall finishes are in place.

ADD \$ 2,000.00 to the material price

\$ 3,250.00

Note: Due to current fluctuations in stainless steel and aluminum prices, we are required to review all pricing after 30 days prior to accepting a purchase order for any products containing stainless steel or aluminum.

INSTALLATION AVAILABLE ON ALL MATERIALS UPON REQUEST, IF NOT SHOWN ABOVE

F.O.B. Factory, Freight allowed jobsite
Taxes: Not Included
By: M. Keith West, FCSI, CCPR **

MS COR# 17854-3C
TERMS: NET, 30 DAYS

Accepted: _____

This proposal is subject to the approval of the architect.

Prices subject to change 30 days after date, and subject to acceptance by our suppliers. All agreements contingent upon strikes, accidents, or delays unavoidable or beyond our control.



April 13, 2023

Catoria P. Martin
City Attorney
City of Jackson, MS
Post Office Box 2779
Jackson, MS 39207

Re: Arts Center – Clean Out Floor Drain

Dear Ms. Martin:

Please find attached a proposal from Roto Rooter in the amount of \$387.95. I have reviewed the proposal and recommend it be accepted.

Roto Rooter required immediate payment. Benchmark paid via credit card. Payment needs to be made to Benchmark.

Please let me know if you have any questions.

Sincerely,

David Marsh,
President

Accepted by: 
City of Jackson, Mississippi

NOTE: This was emergency work that needed correction immediately in order to stop or mitigate damage to adjacent work. The drain was clogged creating an overflow in other spaces. The Roto Rooter work solved the problem. There was no time for preapproval.

1867 Crane Ridge Dr., Suite 200-A, Jackson, MS 39216 • P.O. Box 31177 Jackson, MS 39286-1177
Phone 601-362-6110 • Fax 601-362-9612 • www.benchmarkms.com



Roto-Rooter
PO Box 720539
Byram, MS 39272
(601) 353-3333
*(900) 438-7686
Fax (601) 371-7423
License * Federal ID #54-2166713
Operated as an Independent Contractor

Invoice # 559-360888
Invoice Date 4/7/2023
Technician 181 Chauncy Gates
Additional Tech
Location Jackson MS
Customer Class Commercial

Bill To:
Arts Center Of Mississippi
225 E Pascagoula St
Jackson, Mississippi 39201

Job Site:
Arts Center Of Mississippi
225 E Pascagoula St
Jackson, MS 39201
michaelstennett@live.com
(601) 941-7250

Invoice Details

Repair Code	Labor Description
401-D-C	Camera Floor Drain Guarantee - 1 Week Ran camera through floor drain in mens restroom tried to run camera through c/o but couldn't get past bottom of drain

Total Tax	\$387.95 \$31.04						
Total Invoice	\$448.99 ¹						
 →	<table border="0"> <tr> <td>Payment Type</td> <td>Payment Amount</td> </tr> <tr> <td>Credit Card 272473</td> <td>\$418.99</td> </tr> <tr> <td>Amount Due</td> <td>\$0.00</td> </tr> </table>	Payment Type	Payment Amount	Credit Card 272473	\$418.99	Amount Due	\$0.00
Payment Type	Payment Amount						
Credit Card 272473	\$418.99						
Amount Due	\$0.00						

COMPLETION: I acknowledge completion of the described work which has been done to my complete satisfaction.

Customer Name: Arts Center Of Mississippi
Signature GeoTimestamp: 2023-4-7 21:04 GMT 32.26755484854477, -90.18533530194182

Customer Signature: 

Roto-Rooter Services Company Terms and Conditions

The following terms apply to all work performed by Roto-Rooter or its affiliates ("us") for the customer indicated on our invoice ("you").

- 1. Your Responsibilities.** You agree to (a) remove any hazards, obstructions or dangerous conditions around the job site, not caused by our work, (b) limit access to the job site so that people not working on our job are not exposed to dangerous conditions relating to our job, (c) place appropriate warnings to warn of dangerous conditions when we are not on the job site, and (d) provide us with adequate access.
- 2. Exceptions to Our Responsibilities.** We are not responsible for (a) personal injury, property damage or other damage or loss to you or others arising out of our work, except to the extent caused by our negligence or failure to perform the work in accordance with the contract between us; (b) defective, damaged, or deteriorated lines, mold, lead piping, or other unexpected or undisclosed conditions, and the consequences of such conditions, including delays, broken fixtures or lines, and lodged equipment (if we encounter such a condition, we may stop work and you will pay us a reasonable charge for the work performed); (c) the time required to complete our work with reasonable diligence; (d) unless explicitly stated in writing, any damages necessary to complete our work, including damages to landscaping, walls painting, tile or concrete or similar items; (e) damage caused by the removal of any clean out, drain cover or cap; or (f) tasks we perform in accordance with your specific instructions.
- 3. Release and Hold Harmless.** You release us from (and if you are a commercial customer, you will defend and indemnify us and hold us harmless against) all damages, claims, demands, settlements, judgments, liabilities, costs and expenses, including reasonable attorneys' fees, allegedly arising out of (a) breach of your responsibilities under paragraph 1, or (b) matters for which we disclaim responsibility under paragraph 2.
- 4. Our Guarantee.** If we provide a parts or equipment guarantee, as your exclusive remedy, we will give you the benefit we receive, if any, under the manufacturer's warranty. If we provide a service guarantee, it covers only drainage failure in the line serviced, and defective plumbing workmanship, during the guarantee term. As your exclusive remedy under our service guarantee, we will at our option, either do the work again at no labor cost or refund your payment. Guarantees do not apply to problems arising out of main sewer line backup or improper, abnormal or unanticipated use or conditions. Except as explicitly stated in writing, we are not giving any guarantees or making any warranties. WE DISCLAIM ANY IMPLIED WARRANTIES OF MERCHANTABILITY OR FITNESS FOR A PARTICULAR PURPOSE. You may transfer a guarantee of plumbing repair or replacement to a person who purchases the property, but you may not transfer a drain cleaning or toilet auger guarantee. Your transferee must present the warranty claim to Roto-Rooter at the time we perform our work. For problems or inquiries, you should contact our General Manager at the phone number listed on our invoice.
- 5. Limitation of Damages.** Our liability to you for any claim arising out of our work on any job (other than a claim permitted by these terms for personal or bodily injury) will in no event exceed three times the amount you actually pay us for the work on that job. EXCEPT FOR A CLAIM PERMITTED BY THESE TERMS FOR PERSONAL OR BODILY INJURY OR PROPERTY DAMAGE, YOU WAIVE ANY RIGHT TO RECOVER INCIDENTAL DAMAGES, CONSEQUENTIAL DAMAGES OR DELAY DAMAGES.
- 6. Overdue Amounts.** If you fail to pay us any amount when due, we will charge you interest on the amount due at the rate of 1.5% per month (but not exceeding the highest rate legally permissible). In the event check is returned, you are responsible for all related bank fees. You will reimburse us for the reasonable attorneys' fees we incur in all stages of collection.
- 7. General.** These terms are part of our contractual agreement and will prevail over any inconsistent terms in any other agreement between us, including the terms of any purchase order, and may be modified only in a written instrument signed by both of us which specifically refers to the provisions to be modified. If any of these terms is held invalid or unenforceable, the remaining provisions will not be affected and will continue to apply.
- 8. Discrimination.** We will abide by the requirements of 41 CFR SS 60-1.4(a) and 60-741.5(a). These regulations prohibit discrimination against qualified individuals with disabilities, and prohibit discrimination against all individuals based on their race, color, religion, sex, or national origin. Moreover, these regulations require that we take affirmative action to employ and advance in employment individuals without regard to race, color, religion, sex, national origin or disability.

HOW TO RESOLVE A PROBLEM

- Contact the manager at your local Roto-Rooter office.
- The manager may be reached at the phone number printed on this invoice.



April 11, 2023

Catoria P. Martin
City Attorney
City of Jackson, MS
Post Office Box 2779
Jackson, MS 39207

Re: Thalia Mara – Flagpoles

Dear Ms. Martin:

Please find attached a proposal from A Complete Flag Source in the amount of \$27,717.30. I have reviewed the proposal and recommend it be accepted.

Please let me know if you have any questions.

Sincerely,

David Marsh,
President

Accepted by: 
City of Jackson, Mississippi

REGULAR MEETING OF THE CITY COUNCIL
TUESDAY, APRIL 25, 2023 10:00 A.M.

135

David Marsh

Tuesday, April 11, 2023 at 12:42:23 PM Central Daylight Time

Subject: FW: Flagpole quote for Thalia Mara Hall
Date: Thursday, April 6, 2023 at 4:19:40 PM Central Daylight Time
From: Jim McIntyre
To: David Marsh
Attachments: image001.jpg, image002.jpg, image003.jpg

From: Jim McIntyre
Sent: Tuesday, April 04, 2023 12:49 PM
To: mdmarsh11@gmail.com
Cc: ACFS Sales 2 <sales2@completeflags.com>
Subject: Flagpole quote for Thalia Mara Hall

Revised flagpole quote / David Marsh 4-4-23

David – Please find below my quote for pulling two flagpoles, relocating both & a third flagpole on the East side of the building. The third will be as close to the other two as possible. The holes will be by hydro excavated to eliminate some debris & mess, the sleeves set in concrete & pads formed for flagpole base. Two poles pulled & relocated to East side of building, a third matching flagpole to be installed in a line behind the statue of King of Spain. Third flagpole to be delivered by mid April. Holes dug & sleeve set as soon as site & approval allows.

Turn key flagpole installation - \$ 27,717.30. This is as close an estimate as I can offer & should hold true unless an unknown underground surprise causes a delay & diversion of location.

Page 1 of 2

Jim McIntyre
A Complete Flag Source, Inc.
5295 I - 55 North, Ste A
Jackson, Ms. 39206
OFF- 601- 362 - 9333
FAX- 601- 362 - 9383
Cell - 601- 506 - 1103
jim@completeflags.com

<http://www.completeflags.com/>



CITY OF JACKSON FLAG

See Us on Facebook -

<https://www.facebook.com/pages/A-Complete-Flag-Source/597653156975532>

Page 2 of 2



April 11, 2023

Catoria P. Martin
City Attorney
City of Jackson, MS
Post Office Box 2779
Jackson, MS 39207

Re: Thalia Mara – Tree Trimming

Dear Ms. Martin:

Please find attached a proposal from Big John's Tree Service in the amount of \$6,250.00. I have reviewed the proposal and recommend it be accepted.

Please let me know if you have any questions.

Sincerely,

David Marsh
David Marsh,
President

Accepted by: *Chad Anderson*
City of Jackson, Mississippi

1867 Crane Ridge Dr., Suite 200-A, Jackson, MS 39216 • P.O. Box 31177 Jackson, MS 39296-1177
Phone 601-362-6110 • Fax 601-362-9812 • www.benchmarkms.com



Big John's Tree Service
P.O. Box 321064
Flowood, MS 39232
(601) 941-7773

JOHNNIE ROLAND
Owner

Big John's Tree Service does hereby contract with Benchmark Construction - Thalia Mara Hall,
Owner, of the subject property (listed below), to perform such specific services as listed below. The contract price
is \$_____. Full payment is due in full upon completion of services.

SUBJECT PROPERTY ADDRESS

Address: 255 E Pascagoula Street Phone: Max Marsh 601-454-5622
City/State/Zip: Jackson, MS 39201 Email: mdmarsh11@gmail.com

SPECIFIC SERVICES TO BE PERFORMED

1. Raise & clean up canopy on (1) Ash @ corner of E. Pascagoula & West Street.	
Haul Off Debris.	<u>\$1,100.00</u>
2. Take Down, Haul Off & Grind Stump (1) Crape Myrtle @ sidewalk corner near Louis XIV statue.	<u>\$350.00</u>
3. Raise & Clean up canopy on (1) Ash on south side of Louis XIV Statue on West Street.	<u>\$900.00</u>
4. Remove shrubs around Louis XIV statue.	<u>\$600.00</u>
5. Clean up (5) Crape Myrtles along West Street down to Crape Myrtle @ Windsor Columns. Haul Off Debris.	<u>\$650.00</u>
6. Raise & Clean up canopy on (3) Drake Elms on West side of building @ covered entry/ parking lot.	<u>\$800.00</u>
7. Clean up canopy on (3) Crape Myrtles @ Arts Center crossover.	<u>\$350.00</u>

_____ I Understand that taking trees down is a construction process and some damage may occur to the yard
and landscape.

_____ I Understand that **Big John's Tree Service** is not liable for any underground utilities unless property
marked.

Client's Signature: _____ Date: _____
Representative: Kenneth Anderson Date: 04.07.23 Pg.1



Big John's Tree Service
P.O. Box 321064
Flowood, MS 39232
(601) 941-7773

JOHNNIE ROLAND
Owner

Big John's Tree Service does hereby contract with Benchmark Construction - Thalia Mara Hall,
Owner, of the subject property (listed below), to perform such specific services as listed below. The contract price
is \$_____. Full payment is due in full upon completion of services.

SUBJECT PROPERTY ADDRESS

Address: 255 E. Pascagoula Street Phone: Max Marsh 601-454-5622
City/State/Zip: Jackson, MS 39201 Email: mdmarsh11@gmail.com

SPECIFIC SERVICES TO BE PERFORMED

8. Clean up (2) Ash @ Windson Columns. Haul Off Debris. **\$1,500.00**

TOTAL OF ALL:
\$6,250

____ I Understand that taking trees down is a construction process and some damage may occur to the yard
and landscape.

____ I Understand that Big John's Tree Service is not liable for any underground utilities unless property
marked.

Client's Signature: _____ Date: _____

Representative: Kenneth Anderson Date: 04/07/2023 Pg.2



April 6, 2023

Catoria P. Martin
City Attorney
City of Jackson, MS
Post Office Box 2779
Jackson, MS 39207

Re: Thalia Mara - Escalator

Dear Ms. Martin:

Please find attached a proposal from Schindler Elevator in the amount of \$28,657.00. I have reviewed
the proposal and recommend it be accepted.

Please let me know if you have any questions.

Sincerely,

David Marsh,
President

Accepted by:
City of Jackson, Mississippi



Schindler Elevator Corporation
5251 Greenway Drive
Jackson, MS 39204-3212
Phone:
Fax:

UPGRADE ORDER AGREEMENT

Date: 04/08/2023

Estimate Number: JHAN-CQMJK5 (2022.5.1)

To:
Benchmark Construction
1887 Crane Ridge Drive
Suite 208-A
Jackson, MS 39216

Customer:
Thalia Mara Hall
266 East Pascagoula Street
Jackson, MS 39201

Attn: David Marsh

Schindler hereby proposes to furnish and install the following with respect to the equipment located at the above building:

- Secure equipment
- Change obsolete starter contactors in the up unit.
- Install new 3 phase breaker and piping in up and down units
- Adjust step chains on the down unit
- Clean area and run escalators
- Return escalators to service
- While units are open if there is any further damage a secondary proposal will follow.

Price: \$28,657.00, plus applicable taxes. (Quotations valid for 30 days; price based upon work during regular working hours of regular working days.)

*Financing available (see below)



Payment: PO will be provided.
Balance due upon completion, within 30 days of invoice.

Schindler reserves the right not to source material or schedule labor for the above quoted work until initial payment has been received.

Schindler retains title to any equipment furnished hereunder until final payment is made. Late or non-payment will result in assessment of interest charged at a rate of 1 1/2% per month or the highest legal rate available, and any attorneys' fees, expenses, and costs of collection. The customer understands that this is a fixed price proposal. Supporting documentation for materials and/or labor shall not be a condition precedent for payment in full to be made to Schindler.

Available Financing: Schindler understands that the cost of capital improvements can put a strain on a property's budget. For this reason, Schindler has teamed with leading financial organizations (Lender) in an effort to help our customers sort through the best options to fund these capital improvements. The financing is done directly between the Lender and you, our customer. In return, Schindler requires that you enter into a new 5-year maintenance agreement with Schindler.

Often times, other building systems will need upgrades as a part of the elevator or escalator improvements. The cost of the related work can be rolled into the total finance package with the Lender.

As an example, if you finance \$25,000.00 for 60 months, your monthly payment would be approximately \$510.00 plus any applicable state and federal tax. The monthly finance payment is an approximation and will be finalized between you and the Lender.

Financing is subject to the borrower's qualifications, including income, property evaluation, sufficient equity and final credit approval. Approvals are subject to underwriting guidelines, interest rates, and program guidelines. Loans are subject to change without notice based upon eligibility and market conditions. This is not a commitment to make a loan as financing options are subject to credit checks and approval.

This program is offered and provided through third-party financial organizations and are dependent upon those entities' rules, regulations, and restrictions.

If the maintenance agreement is cancelled for any reason prior to the 60-month term, all remaining balances become due immediately.

Your sales representative will be happy to facilitate the process moving forward if you are interested in our financing option. The finance credit approval form can be found attached to this document.



The attached terms and conditions are incorporated herein by reference.

Acceptance by you as owner's agent or authorized representative and subsequent approval by our authorized representative will be required to validate this agreement.

Proposed: [Signature] Accepted: _____
By: Kevin Martin By: _____
For: Schindler Elevator Corporation For: Benchmark Construction
Title: City Representative Title: _____
Date: 4/11/23 Date: _____

Approved:
[Signature]
By: Vincent Henry Don Potts
Title: Branch Manager
Date: 4-11-23

Page 3 of 4
JHAN-QDMXIS
2022.5.1



TERMS AND CONDITIONS

1. Any changes to the building to meet local or state codes are to be made by Purchaser. Any changes in the Work required due to building conditions discovered in the performance of the Work will be paid by Purchaser.
2. No work, service materials or equipment other than as specified hereunder is included or intended.
3. Purchaser retains its normal responsibilities as Owner of the equipment which is subject of this Agreement.
4. Schindler will not be liable for damages of any kind, in excess of the Price of this Agreement, nor in any event for special, indirect, consequential or liquidated damages.
5. Any cutting and patching is by others and not included in this work.
6. Neither party shall be responsible for any loss, damage, detention or delay caused by labor trouble or disputes, strikes, lockouts, fire, explosion, theft, lightning, wind storm, earthquake, floods, epidemics, pandemics, storms, riot, civil commotion, malicious mischief, embargoes, shortages of materials or workmen, unavailability of material from usual sources, government priorities or requests or demands of the National Defense Program, civil or military authority, war, insurrection, failure to act on the part of either party's suppliers or subcontractors, orders or instructions of any federal, state, or municipal government or any department or agency thereof, acts of God, or by any other cause beyond the reasonable control of either party. Delays for the performance or completion of the work shall be extended by such delay of time as may be reasonably necessary to compensate for the delay.
7. We warrant that the work will comply with the specifications and that there will be no defects in materials or workmanship for one year after completion of the work or acceptance thereof by beneficial use, whichever is earlier. Our duty under this warranty is to correct nonconformance or defect at our expense within a reasonable time after the receipt of notice. THE EXPRESS WARRANTIES CONTAINED HEREIN ARE IN LIEU OF ALL OTHER WARRANTIES, EXPRESS OR IMPLIED, INCLUDING ANY WARRANTIES OF MERCHANTABILITY OR FITNESS FOR A PARTICULAR PURPOSE. Purchaser's remedies hereunder are exclusive.
8. Purchaser agrees to defend, indemnify and hold Schindler harmless from and against any claims, lawsuits, demands, judgments, damages, costs and expenses arising out of this Agreement except to the extent caused by or resulting from the sole and direct fault of Schindler.
9. For non-maintenance contract customers, to the extent permitted by Mississippi law, Customer hereby agrees, without limitation, to defend, indemnify, release and hold harmless Schindler and its employees, affiliates, divisions, parent entities, predecessors and successors, representatives and agents from and against all claims, liabilities, losses, injuries, death, damages, fines, penalties, payments, costs, and expenses (including reasonable attorneys' fees and expenses) arising out of or relating to the Work performed by Schindler under this Agreement. **INSURANCE:** At a minimum, Customer shall provide to Schindler insurance coverages set forth within and provide certificates of insurance evidencing such coverage: Comprehensive General Liability (including Products Liability, Completed Operations, Broad Form Property damage, and Blanket Contractual Liability) in the amount of \$2M per occurrence, \$5M aggregate. Schindler Holding, Ltd., Schindler Elevator Corporation, and Schindler Enterprise, Inc. shall appear as additional insureds on the above referenced policies, pursuant to ISO Form CG 2010-11.05, and shall provide a waiver of subrogation in favor of the entities named as additional insureds. Insurance shall be primary over any other valid and collectible insurance. Any deductible/retention is the responsibility of the Named Insured. The City is self-insured.
10. Any proprietary material, information, data or devices contained in the equipment or work provided hereunder, or any component or feature thereof, remains our property. This includes, but is not limited to, any tools, devices, manuals, software, modems, source code/ object codes, passwords. In the event Schindler's maintenance obligation is terminated, the Schindler Ahead features ("SA") (if applicable) will be deactivated and Schindler reserves the right to remove the Schindler Ahead hardware. If Schindler is no longer the maintenance provider, Customer is responsible for obtaining alternative telephone service for the elevator phones.
11. In the event of governmental changes to applicable tariffs, tax rates, including but not limited to sales tax, use tax, excise tax, privilege tax, transaction tax and similar changes, or loss of tax exempt status, Schindler reserves the right to adjust the contract price accordingly to account for all additional cost impacts.
12. We reserve the right to modify price and schedule without penalty due to material or component shortages, increases in inflation and/or material price increases based upon the S&P Material Price Index (MPI).

Page 4 of 4
JHAN-QDMXIS
2022.5.1

Council Member Lindsay moved adoption; **Council Member Hartley** seconded.

Yeas – Banks, Foote, Grizzell, Hartley, Lee and Lindsay.
Nays – None.
Absent – Stokes.

ORDER RATIFYING THE LEASING OF A FORKLIFT AND AUTHORIZING THE PAYMENT OF INVOICES TOTTALLING \$23,097.87 TO H&E EQUIPMENT SERVICES USED FOR WATER DONATED AND DELIVERED TO HAWKINS FIELD.

WHEREAS, the City of Jackson had a water emergency which resulted in the donation and delivery of bottles of water from various sources between September 2022 and March 2023; and

WHEREAS, the water donations were stored and received at Hawkins Field; and

WHEREAS, a forklift was required to be used for the delivery and receipt of the water donations; and

WHEREAS, the forklift was ordered by Randy Spell, the Superintendent of the City of Jackson Municipal garage from H& E Equipment Services; and

WHEREAS, H& E Equipment Services tendered invoices to the City of Jackson; and

WHEREAS, the invoices form H&E Equipment Services incorrectly state that the forklift was ordered by Cornell Wright;

H&E Equipment Services	Invoice No.	Invoice Date	Account Number	Invoice Amount
Telehandler 10K# 50' Reach Forklift	96812119	9/23/2022	1004941	\$4,642.73
Telehandler 6K# 30' Reach Forklift	96814803	9/23/2022		\$2,765.02
Telehandler 6K# 30' Reach Forklift	96876413	9/23/2022		\$2,615.02
Telehandler 6K# 30' Reach Forklift	96932921	11/18/2022		\$2,615.02
Telehandler 6K# 30' Reach Forklift	96994398	12/16/2022		\$2,615.02
Telehandler 6K# 30' Reach Forklift	97047276	1/23/2023		\$2,615.02
Telehandler 6K# 30' Reach Forklift	97104649	2/21/2023		\$2,615.02
Telehandler 6K# 30' Reach Forklift	97163209	3/21/2023		\$2,615.02
Total				\$23,097.87

WHEREAS, due to the circumstances of the emergency, the procurement of these services was done without prior approval through a purchase order by the governing authorities.

IT IS, THEREFORE, ORDERED that the rental of the forklift from H& E Equipment Services is ratified.

IT IS FURTHER ORDERED that payment of the invoices indicated in this order is approved.

Council Member Grizzell moved adoption; **Vice President Lee** seconded.

President Foote recognized **Terry Williamson, Legal Counsel**, who provided a brief overview of said item.

Thereafter, **President Foote**, called for a vote of said item:

Yeas – Banks, Foote, Grizzell, Hartley, Lee and Lindsay.
Nays – None.
Absent – Stokes.

* * * * *

There came on for consideration Agenda Item No. 17:

ORDER AUTHORIZING THE OFFICE OF THE CITY ATTORNEY TO ENTER INTO A BINDING APPRAISAL AGREEMENT WITH ZURICH INSURANCE IN THE MATTER OF CITY OF JACKSON V. ZURICH, INS., IN THE UNITED STATES DISTRICT COURT OF THE SOUTHERN DISTRICT OF MISSISSIPPI; CAUSE NO. 3:19-CV-805-DPJ-FKP. **President Foote** stated said item would be taken up in Executive Session.

* * * * *

ORDER REVIEWING AND CONTINUING AUGUST 29, 2022 STATE OF EMERGENCY.

WHEREAS, on August 29, 2022, the Mayor issued a proclamation of emergency as a result of (1) excessive rainfall and extreme flooding, (2) the March 7, 2020 Safe Drinking Water Act (SDWA) Emergency Administrative Order (EAO); (3) the February 2021 system-wide failure due to extreme water conditions that caused pipes to freeze and lose pressure; (4) the July 1, 2021 SDWA Administrative Order of Consent (AOC); (5) the July 29, 2022 Boil Water Notice which existed for more than thirty (30) days; and (6) the August 25, 2022 flooding of the Pearl River, which lead to problems with treating water at the O.B. Curtis Water Plant; and

WHEREAS, Section 33-15-17(d) of the Mississippi Code allows the mayor of a municipality to proclaim a local emergency and authorizes the governing body of a municipality to review and approve or disapprove the need for continuing the local emergency at its first regular meeting following such proclamation or at a special meeting; and

WHEREAS, Section 33-15-5 (h) of the Mississippi Code defines an emergency as “any occurrence, or threat thereof, whether natural, technological, or man-made, in war or in peace, which results or may result in substantial injury or harm to the population or substantial damage to loss of property;” and

WHEREAS, Section 33-15-5 (g) of the Mississippi Code defines a local emergency as “the duly proclaimed existence of conditions of disaster or extreme peril to the safety of person and property within the territorial limits of a...municipality caused by such conditions as...water pollution...or other natural or man-made conditions, which conditions are or are likely to be beyond the control of the services, personnel, equipment and facilities of the political subdivision and require the combined forces of other subdivisions or of the state to combat;” and

WHEREAS, pursuant to Section 33-15-17 (b) of the Mississippi Code, the City “is authorized to exercise the powers vested under [Section 33-15-1, et seq.,] in light of the exigencies of the extreme emergency situation without regard to time-consuming procedures and formalities prescribed by law pertaining to the performance of public work, entering into contracts, the incurring of obligations...and the expenditure of public funds....

NOW, THEREFORE, IT IS ORDERED THAT we the governing body of the City of Jackson, Mississippi, pursuant to the authority vested in the body by Section 33-15-17(d) of the Mississippi Code of 1972, as amended, and in the public interest and for the general welfare of the City of Jackson, do hereby approve of the continued need for a civil emergency for the entire City of Jackson for the reasons set forth in this Order.

Vice President Lee moved adoption; Council Member Lindsay seconded.

Yeas – Banks, Foote, Grizzell, Hartley, Lee and Lindsay.
Nays – None.
Absent – Stokes.

* * * * *

ORDER REVIEWING AND CONTINUING STATE OF EMERGENCY.

WHEREAS, on February 18, 2020, the Jackson City Council, pursuant to Section 33-15-17(8)(d) of the Mississippi Code of 1972, as amended, passed an Order Declaring the Need to Continue the State of Emergency that was issued on February 13, 2020 by Chokwe A. Lumumba, Mayor of the City of Jackson, Mississippi; and

WHEREAS, the Jackson City Council, in the February 18, 2020 Order, found that flood waters and wide spread drainage system issues had affected several Jackson creeks, including, but not limited to: Belhaven Creek; Bogue Chitto Creek; Caney Creek; Eubanks Creek; Hanging Moss Creek; Lynch Creek; Purple Creek; Three Mile Creek; Town Creek; Travon Creek; and White Oak Creek; and

WHEREAS, the Jackson City Council, in the February 18, 2020 Order, found that the flood waters and wide spread drainage system issues caused extensive damages to homes, business, public property, and threatened the safety of the citizens and property of the City of Jackson, Mississippi, requiring the exercise of extraordinary measures; and

WHEREAS, the Jackson City Council, in the February 18, 2020 Order, found that all efforts should be taken to protect people and property in consideration of the health, safety, and welfare of the City’s residents and the protection of their property within the affected areas; and

WHEREAS, the Jackson City Council, on March 17, 2020; April 14, 2020; May 12, 2020, June 9, 2020, July 7, 2020, August 4, 2020, September 1, 2020, September 29, 2020, October 27, 2020, November 24, 2020, December 22, 2020, January 19, 2021, February 17, 2021, March 30, 2021, April 27, 2021, May 25, 2021, June 22, 2021, July 20, 2021, August 31, 2021, September 28, 2021, October 26, 2021, November 23, 2021, December 21, 2021, January 25, 2022, February 15, 2022, March 29, 2022, April 26, 2022, May 24, 2022, June 21, 2022, July 19, 2022, August 30, 2022, September 27, 2022, October 25, 2022, November 22, 2022, December 20, 2022, January 31, 2023, February 28, 2023 and March 21, 2023 pursuant to Section 33-15-17(8)(d) of the Mississippi Code of 1972, reviewed the need for and continued the local emergency; and

WHEREAS, pursuant to Section 33-15-17(8)(d) of the Mississippi Code of 1972, as amended, the Jackson City Council has again reviewed the need for continuing the local emergency and determined that the emergency should be continued.

IT IS, THEREFORE, HEREBY ORDERED that said Order Declaring the Need to Continue the Declared State of Emergency as delineated by the Jackson City Council, remains in full force and effect and shall be reviewed again in thirty (30) days in accordance with Section 33-15-17(8)(d) of the Mississippi Code of 1972, as amended.

Council Member Lindsay moved adoption; Vice President Lee seconded.

President Foote recognized Fidelis Malembeka, Chief Financial Officer and Terry Williamson, Legal Counsel, who provided a brief overview of said item.

Thereafter, President Foote, called for a vote of said item:

Yeas – Banks, Foote, Grizzell, Hartley, Lee and Lindsay.
Nays – None.
Absent – Stokes.

* * * * *

There came on for Discussion, Agenda Item No. 20:

DISCUSSION: LITIGATION: President Foote stated said item would be discussed later in the meeting during Executive Session.

DISCUSSION: RELOCATION OF WSBA AND OTHER DEPARTMENTS LOCATED AT THE METROCENTER MALL: President Foote recognized **Council Member Grizzell** who expressed concerns in regards to the relocation of WSBA causing some customers to have to pay service fees at bill payment stations because they could not drive to Pearl to pay in person. **President Foote** recognized **Chokwe Antar Lumumba, Mayor**, who stated that City officials were aware of the potential problem and were looking for ways to address it.

The following reports/announcements were provided during the meeting:

- **Council Member Hartley** announced the following:
 - Jackson Public Schools will hold community meetings at Pecan Park Elementary School April 25, 2023, Isabelle Elementary School April 26,2023, and Jim Hill High School April 27, 2023 at 5:30 each night.
 - Offer condolences and request prayers for Deputy Clerk Fran Bridges for the passing of her brother.
 - Ask for prayers for the Stokes family.

- **Mayor Chokwe Antar Lumumba** announced the following:
 - Acknowledged and recognized all City Clerks, Council Clerks and Deputy Clerks for their hard work and dedication during Municipal Clerks Week April 30th through May 6th.

President Foote recognized **Council Member Banks** who stated that the Council had received the following report for review: **MONTHLY REPORT OF PRIVILEGE TAXES AS REQUIRED ACCORDING TO SECTION 27-17-501 OF THE MISSISSIPPI CODE ANNOTATED OF 1972.**

President Foote recognized **Council Member Banks** who moved, seconded by **Council Member Hartley** to go into Closed Session to take up Agenda Items 8,7, and 20. The motion prevailed by the following vote:

Yeas – Banks, Foote, Grizzell, Hartley, Lindsay and Lee.
Nays – None.
Absent – Stokes.

President Foote announced to the public that the Council voted to go into Closed Session to discuss going into Executive Session regarding “Potential Litigation and Litigation”.

During Closed Session, **Council Member Hartley** moved, seconded by **Vice President Lee** to go into Executive Session regarding “Potential Litigation and Litigation”.

Yeas – Banks, Foote, Grizzell, Hartley, Lindsay and Lee.

Nays – None.
Absent – Stokes.

* * * * *

President Foote recognized **Council Member Grizzell** who moved, seconded by **Council Member Hartley**, to come out of Executive Session. The motion prevailed by the following vote:

Yeas – Banks, Foote, Grizzell, Hartley, Lindsay and Lee.
Nays – None.
Absent – Stokes.

* * * * *

President Foote announced to the public that the Council voted to come out of Executive Session and action was taken.

* * * * *

During Executive Session, the Council took action on Agenda Item No. 17:

ORDER AUTHORIZING THE OFFICE OF THE CITY ATTORNEY TO ENTER INTO A BINDING APPRAISAL AGREEMENT WITH ZURICH INSURANCE IN THE MATTER OF CITY OF JACKSON V. ZURICH, INS., IN THE UNITED STATES DISTRICT COURT OF THE SOUTHERN DISTRICT OF MISSISSIPPI; CAUSE NO. 3:19-CV-805-DPJ-FKP.

WHEREAS, the City of Jackson filed a lawsuit against Zurich Insurance in the United States District Court of Southern District of Mississippi for issues arising out of insurance coverage for damaged structures sustained in the hail storm of 2013; and

WHEREAS, the Office of the City Attorney vigorously prosecuted the action; and

WHEREAS, the Office of the City Attorney participated in a Settlement Conference with Zurich Insurance and the United States Magistrate Judge; and

WHEREAS, approximately 160 structures were damaged in the 2013 hail storm, and neither the City of Jackson nor Zurich Insurance could agree on the value of the property or the amount of loss; and

WHEREAS, the Commercial Property Conditions of the insurance policy with Zurich Insurance allows the parties to submit to a binding appraisal process in the event that the parties cannot agree on the value of loss; and

WHEREAS, pursuant to the binding appraisal process, an independent umpire will determine the value of loss for each structure; and

WHEREAS, the Office of the City Attorney believes that the best interest of the City of Jackson would be served by foregoing costly and lengthy litigation and entering into a Binding Appraisal Agreement with Zurich Insurance Company to have an independent umpire resolve this matter.

IT IS HEREBY ORDERED that the Office of the City Attorney is authorized to enter into a Binding Appraisal Agreement with Zurich Insurance to resolve the pending federal court litigation in the United States District Court of the Southern District of Mississippi, Cause No. 3:19-cv-805-DPJ-FKP.

IT IS HEREBY ORDERED that the Office of the City Attorney shall be authorized to perform those acts necessary to affect the resolution of this matter.

Council Member Banks moved adoption; **Council Member Lindsay** seconded.

Yeas – Banks, Foote, Grizzell, Hartley, Lee and Lindsay.
Nays – None.

Absent – Stokes.

* * * * *

ORDER APPROVING CLAIMS NUMBER 28732 to 28745 APPEARING AT PAGES 394 TO 400 INCLUSIVE THEREON, ON MUNICIPAL “DOCKET OF CLAIMS”, IN THE AMOUNT OF \$3,590,283.99 AND MAKING APPROPRIATIONS FOR THE PAYMENT THEREOF.

IT IS HEREBY ORDERED that claims numbered 28732 to 28745 appearing at pages 394 to 400, inclusive thereon in the Municipal “Docket of Claims”, in the aggregate amount of \$3,590,283.99 are hereby approved for payment and said amount is expressly appropriated for the immediate payment thereof.

IT IS FURTHER ORDERED that there is appropriated from the various funds the sums necessary to be transferred to other funds for the purpose of paying the claims as follows:

FROM:	TO ACCOUNTS PAYABLE FUND
GENERAL FUND	833,505.87
SEIZURE & FORF PORP-STATE	268,203.29
TECHNOLOGY FUND	67,968.66
PARKS & RECR. FUND	102,418.84
LANDFILL/SANITATION FUND	205,768.77
FIRE PROTECTION	24,997.00
STATE TORT CLAIMS FUND	56,854.30
WATER/SEWER OP & MAINT FUND	106,397.34
WATER/SEWER CAPITAL IMPR FUND	166,649.80
EMPLOYEES GROUP INSURANCE FUND	6,972.86
KELLOGG FOUNDATION PROJECT	2,708.34
NARCOTICS EVIDENCE ESCROW	1,334.00
HOUSING COM DEV ACT (CDBG) FD	13,761.72
INFRASTRUCTURE BOND 2020 \$32M	58,162.84
1% INFRASTRUCTURE TAX	350,303.24
MADISON SEWAGE DISP OP & MAINT	39.19
WATER/SEWER CAP IMP NOTE 7M	4,148.24
TRANSPORTATION FUND	79,144.95
JXN CONVENTION & VISITORS BUR	262,125.11
2018 TIF BOND \$4.6M – EASTOVER	92,796.14
P E G ACCESS – PROGRAMMING FUND	7,476.88
CDBG COVID CARES	1,258.00
ZOOLOGICAL PARK	13,631.97
LIBRARY FUND	9,453.50
DFA – SB2971 – PETE BROWN GOLF	4,800.00
DFA – THALIA MARA HALL \$2M	26,806.00
MDOT – CMPDD PROJECTS	761,983.15
2022 GO PLANETARIUM BOND \$7.5M	60,613.99
TOTAL	<u>\$3,590,283.99</u>

Vice President Lee moved adoption; Council Member Grizzell seconded.

President Foote recognized Fidelis Malembeka, Chief Financial Officer and Terry Williamson, Legal Counsel who provided a brief overview of said item.

Thereafter, **President Foote**, called for a vote of said item:

Yeas – Grizzell and Lee.
Nays – Banks, Foote, Hartley.
Absent – Lindsay and Stokes.

Note: Said item failed for a lack of a majority vote.

* * * * *

Note: Council Member Lindsay left the meeting during the discussion.

* * * * *

There being no further business to come before the City Council, it was unanimously voted to adjourn until the Special Council/Citizen’s Agenda Meeting at 6:00 p.m. on April 27, 2023. At 11:21 a.m., the Council stood adjourned.

PREPARED BY:

APPROVED:

CLERK OF COUNCIL

_____,
COUNCIL PRESIDENT DATE

MAYOR

ATTEST:

CITY CLERK

* * * * *

#5

**SPECIAL MEETING OF THE CITY COUNCIL
THURSDAY, APRIL 27, 2023 6:00 P.M.**

BE IT REMEMBERED that a Special Meeting of the City Council of Jackson, Mississippi, was called by a majority of the City Council Members and notices having been placed by the Clerk of Council at 12:59 p.m. Wednesday, April 26, 2023 in the Clerk of Council’s Office, electronic notifications to all Council Members, on the City’s website and on the public bulletin board in City Hall, relative to: (1) Claims. (2) Public Comments: Citizen Agenda. The meeting was convened in the Council Chambers located at 219 S. President Street at 6:00 p.m. on April 27, 2023 being the fourth Thursday of said month, when and where the following things were had and done to wit:

Present: Council Members: Angelique Lee, Council Vice President, Ward 2 (via teleconference); Brian C. Grizzell, Ward 4; Aaron Banks, Ward 6 (via teleconference) and Virgi Lindsay, Ward 7. Directors: Safiya Omari, Chief of Staff; Shanekia Mosley-Jordan, Clerk of the Council; Sabrina Shelby, Chief Deputy Clerk of the Council and Carrie Johnson, Deputy City Attorney.

Absent: Ashby Foote, Council President, Ward 1; Kenneth I. Stokes, Ward 3 and Vernon Hartley, Ward 5.

The meeting was called to order by **Council Member Lindsay**.

ORDER APPROVING CLAIMS NUMBER 28732 to 28745 APPEARING AT PAGES 394 TO 400 INCLUSIVE THEREON, ON MUNICIPAL “DOCKET OF CLAIMS”, IN THE AMOUNT OF \$3,590,283.99 AND MAKING APPROPRIATIONS FOR THE PAYMENT THEREOF.

IT IS HEREBY ORDERED that claims numbered 28732 to 28745 appearing at pages 394 to 400, inclusive thereon in the Municipal “Docket of Claims”, in the aggregate amount of \$3,590,283.99 are hereby approved for payment and said amount is expressly appropriated for the immediate payment thereof.

IT IS FURTHER ORDERED that there is appropriated from the various funds the sums necessary to be transferred to other funds for the purpose of paying the claims as follows:

FROM:	TO ACCOUNTS PAYABLE FUND
GENERAL FUND	833,505.87
SEIZURE & FORF PORP-STATE	268,203.29
TECHNOLOGY FUND	67,968.66
PARKS & RECR. FUND	102,418.84
LANDFILL/SANITATION FUND	205,768.77
FIRE PROTECTION	24,997.00
STATE TORT CLAIMS FUND	56,854.30
WATER/SEWER OP & MAINT FUND	106,397.34
WATER/SEWER CAPITAL IMPR FUND	166,649.80
EMPLOYEES GROUP INSURANCE FUND	6,972.86
KELLOGG FOUNDATION PROJECT	2,708.34
NARCOTICS EVIDENCE ESCROW	1,334.00
HOUSING COM DEV ACT (CDBG) FD	13,761.72
INFRASTRUCTURE BOND 2020 \$32M	58,162.84
1% INFRASTRUCTURE TAX	350,303.24
MADISON SEWAGE DISP OP & MAINT	39.19

**SPECIAL MEETING OF THE CITY COUNCIL
THURSDAY, APRIL 27, 2023 6:00 P.M.**

WATER/SEWER CAP IMP NOTE 7M	4,148.24
TRANSPORTATION FUND	79,144.95
JXN CONVENTION & VISITORS BUR	262,125.11
2018 TIF BOND \$4.6M – EASTOVER	92,796.14
P E G ACCESS – PROGRAMMING FUND	7,476.88
CDBG COVID CARES	1,258.00
ZOOLOGICAL PARK	13,631.97
LIBRARY FUND	9,453.50
DFA – SB2971 – PETE BROWN GOLF	4,800.00
DFA – THALIA MARA HALL \$2M	26,806.00
MDOT – CMPDD PROJECTS	761,983.15
2022 GO PLANETARIUM BOND \$7.5M	60,613.99
TOTAL	<u>\$3,590,283.99</u>

Council Member Grizzell moved adoption; **Council Member Lindsay** seconded.

Council Member Lindsay recognized **Fidelis Malembeka, Chief Financial Officer**, who provided a brief overview of said item.

Thereafter, **Council Member Lindsay**, called for a vote of said item:

- Yeas – Grizzell, Lee and Lindsay.
- Nays – Banks.
- Absent – Foote, Hartley and Stokes.

* * * * *

PUBLIC COMMENTS: **Council Member Lindsay** recognized **Janelle Westley-Edwards**, who presented the Council with a collaboration plan that would bring fun and fitness to the City of Jackson and requested a letter of support from the Administration.

* * * * *

PUBLIC COMMENTS: **Council Member Lindsay** recognized **Vinson Gibbs**, who expressed concerns regarding the members of the City Council and the Administration fighting against each other and should be working together for the citizens of Jackson.

* * * * *

There being no further business to come before the City Council, it was unanimously voted to adjourn until the Regular Council Meeting at 10:00 a.m. on May 9, 2023. At 6:26 p.m., the Council stood adjourned.

PREPARED BY:

APPROVED:

CLERK OF COUNCIL

_____, _____
COUNCIL PRESIDENT DATE

MAYOR

ATTEST:

CITY CLERK

* * * * *

#6

**REGULAR MEETING OF THE CITY COUNCIL
TUESDAY, MAY 9, 2023 10:00 A.M.**

BE IT REMEMBERED that a Regular Meeting of the City Council of Jackson, Mississippi, was convened at City Hall at 10:00 a.m. on May 9, 2023, being the second Tuesday of said month, when and where the following things were had and done to wit:

Present: Council Members: Ashby Foote, Council President, Ward 1; Angelique Lee, Vice-President, Ward 2; Brian Grizzell, Ward 4; Vernon Hartley, Ward 5; Aaron Banks, Ward 6 and Virgi Lindsay, Ward 7. Directors: Safiya Omari, Chief of Staff; Shanekia Mosley-Jordan, Clerk of Council; Sabrina Shelby, Chief Deputy Clerk of Council and Catoria Martin, City Attorney.

Absent: Kenneth Stokes, Ward 3.

The meeting was called to order by **President Foote**.

The invocation was offered by **Pastor Tony McBride of Greater Mt. Olive M.B. Church**.

The Council recited the **Pledge of Allegiance**.

The following individuals provided public comments during the meeting:

- **Anthony Brown** spoke on discussion item 34 expressing concerns regarding frequent flooding at his business J & A Fuel Store located at the Freedom Corner intersection.

President Foote requested that Agenda Item No. 28 be moved forward on the Agenda. Hearing no objections, the Clerk read the following:

RESOLUTION OF THE CITY COUNCIL OF JACKSON, MISSISSIPPI IN SUPPORT OF THE 60TH ANNIVERSARY OBSERVANCE OF THE MEDGAR WILEY EVERS HOMECOMING, JUNE 6-12, 2023.

WHEREAS, the Medgar Wiley Evers Homecoming activities will recognize the sixtieth anniversary of the assassination of Mr. Medgar Wiley Evers which occurred in Jackson, Mississippi on June 12, 1963; and

WHEREAS, Medgar Evers was field secretary for the NAACP in Mississippi, a civil rights advocate, and a trailblazer for voting rights and humanitarian efforts on behalf of poor and disenfranchised Mississippians; and

WHEREAS, the entire nation and world join the City of Jackson in recognizing and supporting the 60th Anniversary Observance of the Homecoming of native-born Mississippian, Mr. Medgar Wiley Evers.

THEREFORE, IT IS HEREBY RESOLVED that the City of Jackson is hereby authorized to support and join the 60th Anniversary Observance of the Medgar Wiley Evers Homecoming.

Council Member Grizzell moved adoption; **Council Member Lindsay** seconded.

President Foote recognized **Reena Evers, Civil Rights Activist**, who provided a brief overview of said item.

**Consent Agenda Item No. 6
May 23, 2023
(S.Jordan, Foote)**

Thereafter, **President Foote** called for a vote on said item:

Yeas – Foote, Grizzell, Hartley, Lee and Lindsay.
Nays – None.
Absent – Banks and Stokes.

* * * * *

APPROVAL OF THE APRIL 10, 2023 SPECIAL COUNCIL MEETING MINUTES.

Council Member Grizzell moved adoption; **Council Member Lindsay** seconded.

Yeas – Foote, Lee and Lindsay.
Nays – Grizzell and Hartley.
Absent – Banks and Stokes.

* * * * *

APPROVAL OF THE APRIL 11, 2023 REGULAR COUNCIL MEETING MINUTES.

Council Member Grizzell moved adoption; **Council Member Lindsay** seconded.

Yeas – Foote, Lee and Lindsay.
Nays – Grizzell and Hartley.
Absent – Banks and Stokes.

* * * * *

APPROVAL OF THE APRIL 12, 2023 SPECIAL COUNCIL MEETING MINUTES.

Council Member Grizzell moved adoption; **Council Member Lindsay** seconded.

Yeas – Foote, Lee and Lindsay.
Nays – Grizzell and Hartley.
Absent – Banks and Stokes.

* * * * *

APPROVAL OF THE APRIL 18, 2023 SPECIAL COUNCIL MEETING MINUTES.

Council Member Grizzell moved adoption; **Council Member Lindsay** seconded.

Yeas – Foote, Lee and Lindsay.
Nays – Grizzell and Hartley.
Absent – Banks and Stokes.

* * * * *

President Foote requested that Agenda Item No. 31 be moved forward on the Agenda. Hearing no objections, the Clerk read the following:

NUNC PRO TUNC ORDER OF THE CITY COUNCIL OF JACKSON, MISSISSIPPI TO RETAIN LEGALCOUNSEL.

WHEREAS, the City Council of Jackson, Mississippi, did at a Special Meeting on April 5, 2022, adopt an “Order of the City Council of Jackson, Mississippi to Retain Legal Counsel” related to the City Council’s determination that it required separate representation from two law firms – Martin and Martin, PLLC, and Mills, Scanlon, Dye & Pittman, P.A. – related to certain litigation filed by the Mayor against the City Council; and

WHEREAS, one basis for the need for separate counsel was a determination that a conflict of interest did exist between the office of the City Attorney and the City of Jackson; and

WHEREAS, the rate of pay for those outside attorneys had been proposed at \$325 for Deshun Martin of the Martin and Martin firm, \$325 for John Scanlon of the Mills Scanlon firm, with the Mills Scanlon firm to be retained in accordance with the terms of an engagement letter, including hourly rates (a copy of which is attached hereto); and

WHEREAS, all terms of the Mills Scanlon engagement letter were discussed at the meeting and had also been previously submitted to Ms. Virgi Lindsay, the then City Council president; and

WHEREAS, then-Council president Virgi Lindsay (who served until July 1, 2022, when Mr. Ashby Foote assumed the position of City Council president) did execute an engagement letter with Mills Scanlon the following day, on April 6, 2022, containing those rates for both Mr. Scanlon and his firm (see attached Mills Scanlon engagement letter); and

WHEREAS, the Order adopted by the City Council on April 5, 2022, did correctly reference a rate of pay of \$325 per hour for both Mr. Martin and Mr. Scanlon, but through inadvertent clerical error did not reference all Mills Scanlon rates, despite the clear terms of the Mills Scanlon engagement letter and despite the fact of full discussion of those terms with the City Council at its April 5 meeting; and

WHEREAS, the City Council at its regular meeting on July 5, 2022 (at which time Mr. Ashby Foote had begun his term as Council president), and at its special meeting on July 19, 2022, did adopt similar orders, indicating a need for separate representation from the same two law firms related to certain other litigation, again based on a determination that “a conflict does exist between the City Council and the Mayor’s office rendering the City Attorney unable to represent both the Council and the Mayor”; and

WHEREAS, at its regular meeting on Oct. 11, 2022, the City Council did adopt an Order which in part authorized the City Council’s independent special legal counsel to commence seeking other relief, including where appropriate and necessary, judicial relief” which was to be “at their current rate of pay;” and

WHEREAS, at its special meeting on Jan. 10, 2023, the City Council again adopted an Order which in part authorized the hiring of the City Council’s outside legal counsel to seek a certain judicial ruling in court; and

WHEREAS, each of the above Orders of the governing authority of the City of Jackson (April 5, 2022; July 5, 2022; July 19, 2022; Oct. 11, 2022; and Jan. 23, 2023) became final in the absence of the veto of the Mayor; and

WHEREAS, at all times, it was and is the intent of the City Council in its adoption of all of these Orders herein listed, supra, to authorize the rate for Mills, Scanlon, Dye and Pittman to include the rate for Mr. Scanlon and other rates of his firm, as memorialized in an engagement letter the president of the City Council did, and was authorized to, execute the following day on April 6, 2022; and

WHEREAS, the purpose of a nunc pro tunc order is to correctly evidence a previous action which was not accurately recorded, and the City Council hereby makes a determination that 1) the Order from its April 5, 2022, meeting did not correctly evidence the City Council’s actions which were not accurately recorded, and 2) a nunc pro tunc order is needed in this matter to reflect accurately the City Council’s actions, namely that the Mills Scanlon firm was hired in accordance with the terms of its written engagement letter; and

WHEREAS, the City Council thus and hereby issues this Order, nunc pro tunc, to correctly evidence the previous action(s) of the City Council which was/were not properly recorded – the City Council’s true action, albeit not properly recorded at the time, was to retain and engage the Mills Scanlon firm in accordance with the terms of its written engagement letter; and

WHEREAS, the City Council of Jackson, Mississippi was named as a defendant in the lawsuit styled “Chokwe A. Lumumba, in his official capacity as Mayor of the City of Jackson vs The City Council of Jackson, Mississippi”; and

WHEREAS, the City Council of Jackson, Mississippi has determined that a conflict does exist between the City Attorney’s Office and the City of Jackson; and

WHEREAS, the City Council of Jackson, Mississippi has determined that it is in the best interest of the City of Jackson to defend this lawsuit by retaining the independent legal counsel of Martin and Martin, PLLC and Mills, Scanlon, Dye and Pittman as Co-Counsel; and

WHEREAS, the attorneys with Martin and Martin, PLLC and Mills, Scanlon, Dye and Pittman as Co-Counsel will represent the governing authorities in all matters referencing the lawsuit styled

“Chokwe A. Lumumba, in his official capacity as Mayor of the City of Jackson vs The City Council of Jackson, Mississippi” in the Circuit Court of Hinds County First Judicial District Cause No. 22-194; and

WHEREAS, the governing authorities have determined that such representation by outside counsel shall be limited to the City of Jackson, and shall not include the representation of Mayor Chokwe A. Lumumba individually or in his official capacity; and

WHEREAS, Mr. Deshun Martin with Martin and Martin, PLLC and Mr. John Scanlon of Mills, Scanlon, Dye and Pittman as Co-Counsel are highly experienced with the subject matter involved in this case and have agreed to perform services for the City at an hourly rate of \$325.00 per hour equally, based on the skill and experience of the assigned counsels for the charge tasked; and

WHEREAS, the agreement with Mills, Scanlon, Dye and Pittman shall also include all of the firm’s rates, as memorialized in an engagement letter the president of the City Council is hereby authorized to execute; and

WHEREAS, the City Council President has the authorization to execute a waiver letter with Mills, Scanlon, Dye and Pittman.

IT IS, THEREFORE, ORDERED nunc pro tunc that Mr. Deshun Martin of Martin and Martin, PLLC, and Mr. John Scanlon of Mills, Scanlon, Dye and Pittman as Co-Counsel is retained as the independent legal counsel of the City of Jackson at an hourly rate of \$325.00 per hour based upon the skill and experience of the assigned counsels (with the Mills Scanlon agreement to be as memorialized in its engagement letter the City Council president is hereby authorized to execute) for the charged task for the purpose of defending the City of Jackson in the lawsuit styled “Chokwe A. Lumumba, in his official capacity as Mayor of the City of Jackson vs The City Council of Jackson, Mississippi”.

Mills, Scanlon, Dye & Pittman
ATTORNEYS AT LAW
800 Avery Boulevard North, Suite 101
Ridgeland, Mississippi 39157

Jerry L. Mills
John P. Scanlon
Zachary L. Giddy
John T. Wakefield
Edwin L. Pittman, Of Counsel

Telephone:
(601) 957-2800
Facsimile:
(601) 957-7440
Brad Dye (1933-2018)
James H. Gabriel (1948-2015)
Carolyn B. Mills (1947-2017)

April 6, 2022

City Council of the City of Jackson, Mississippi
c/o Ward 7 Councilwoman Virgi Lindsay, President
219 S. President St.
Jackson, MS 39201

ENGAGEMENT LETTER
In Re: Lumumba vs. City Council of Jackson,
in the Circuit Court of Hinds County, First Judicial District, Cause No. 22-194,
and other litigation between Mayor Chokwe A. Lumumba and
The City Council of Jackson, Mississippi, as directed

Dear Councilwoman Lindsay:

I want to take this opportunity to thank you personally for your consideration of my firm and me to represent the City Council of the City of Jackson. This Engagement Letter will confirm our formal agreement. This agreement is subject to your approval and signature.

The Client will be The City Council of the City of Jackson, Mississippi. We will also submit separately a required waiver of conflict. The Payor and point of contact for our firm will be you, Councilwoman Virgi Lindsay, or your designee, who will authorize both the legal work for, and all payments to, our firm.

The scope of work includes all matters related to, up to and including the litigation between Mayor Chokwe A. Lumumba and The City Council of the City of Jackson, Mississippi, specifically the dispute regarding the determination of the Mayor’s Veto of the City Council’s decision regarding a solid waste collection contract, filed as *Lumumba vs. City Council of Jackson*, in the Circuit Court of Hinds County, First Judicial District, Cause No. 22-194. If there are any other litigation matter or other, related matters, our firm will work on those matters only after being directed to do so by you. Please accept this engagement letter as our attorney-client agreement.

The arrangement for attorney’s fees will be based on the hourly rate of three-hundred seventy-five dollars (\$375.00) per hour for senior partner, three-hundred twenty-five dollars (\$325.00) per hour for junior partner and two hundred dollars (\$200.00) per hour for associate’s work on the case. There will be no initial retainer; we will bill on a monthly basis for any fees and expenses due. Expenses include photocopying, postage, long distance charges, courier services, computer on-line services, court costs, mileage, travel, etc. Payment is due within thirty (30) days

City Council of the City of Jackson, Mississippi
c/o Ward 7 Councilwoman Virgi Lindsay, President
April 6, 2022
Page 2

of receipt of our invoice. Failure to make timely payments may, upon notice, result in the firm's withdrawal as your counsel in this matter.

At the conclusion of this matter, we will retain your legal files for a period of seven (7) years after we close our file. At the expiration of the seven-year period, we will destroy these files unless you notify us in writing that you wish to take possession of them. We reserve the right to charge administrative fees and costs associated with researching, retrieving, copying and delivering such files.

Again, thank you for this opportunity to be of service. Please sign and return a copy of this letter. If you have any questions, please call me at 601-957-2600.

With best regards, I remain,

Sincerely,

Mills, Scanlon, Dye & Pittman



John P. Scanlon

JPS/mmh

Acknowledged and agreed by:

(Name) Virgi Lindsay

(Title) President

Council Member Hartley moved adoption; **President Foote** seconded.

President Foote recognized **Catoria Martin, City Attorney**, who provided a brief overview of said item.

Thereafter, **President Foote**, called for a vote of said item:

Yeas – Foote, Hartley and Lindsay.

Nays – Grizzell and Lee.

Absent – Banks and Stokes.

* * * * *

Note: Council Member Banks arrived to the meeting.

* * * * *

ORDER APPROVING CLAIMS NUMBER 28781 to 28847 APPEARING AT PAGES 421 TO 451 INCLUSIVE THEREON, ON MUNICIPAL “DOCKET OF CLAIMS”, IN THE AMOUNT OF \$7,025,606.41 AND MAKING APPROPRIATIONS FOR THE PAYMENT THEREOF.

IT IS HEREBY ORDERED that claims numbered 28781 to 28847 appearing at pages 421 to 451, inclusive thereon in the Municipal “Docket of Claims”, in the aggregate amount of \$7,025,606.41 are hereby approved for payment and said amount is expressly appropriated for the immediate payment thereof.

IT IS FURTHER ORDERED that there is appropriated from the various funds the sums necessary to be transferred to other funds for the purpose of paying the claims as follows:

FROM:	TO ACCOUNTS PAYABLE FUND
GENERAL FUND	2,015,841.78
SEIZURE & FORF PORP-FED	49,666.67
TECHNOLOGY FUND	31,005.48
PARKS & RECR. FUND	54,382.73
BUSINESS IMPROV FUND (LANDSCP)	58,645.87
LANDFILL/SANITATION FUND	809,534.29

**REGULAR MEETING OF THE CITY COUNCIL
TUESDAY, MAY 9, 2023 10:00 A.M.**

STATE TORT CLAIMS FUND	102,899.38
WATER/SEWER REVENUE FUND	889.29
WATER/SEWER OP & MAINT FUND	1,284,163.06
WATER/SEWER CAPITAL IMPR FUND	36,474.82
DISABILITY RELIEF FUND	107,882.66
EMPLOYEES GROUP INSURANCE FUND	143,287.80
KELLOGG FOUNDATION PROJECT	40,833.33
HOUSING COM DEV ACT (CDBG) FD	20,486.55
UNEMPLOYMENT COMPENSATION REVO	36,302.23
HOME PROGRAM FUND	47.95
H O P W A GRANT – DEPT. OF HUD	104,340.28
INFRASTRUCTURE BOND 2020 \$32M	142,459.66
1% INFRASTRUCTURE TAX	10,982.48
TRANSPORTATION FUND	750,012.21
FONDREN BUSINESS IMPROV FUND	3,962.12
MHC BLIGHT ELIMINATION PROGRAM	27,750.06
SIEMENS SETTLEMENT ACCOUNT	454,045.94
ESG COVID CARES ACT	23,711.67
CDBG COVID CARES	39,418.62
ZOOLOGICAL PARK	38,133.02
LIBRARY FUND	171,704.16
DFA – SB2971 – LIVINGSTON PARK	15,000.00
DFA – SB2971 – PETE BROWN GOLF	63,331.00
DFA – THALIA MARA HALL \$2M	352,134.68
2022 GO PLANETARIUM BOND \$7.5M	32,250.00
BELHAVEN COMMUNITY IMPROVEMENT	4,026.62
TOTAL	<u>\$7,025,606.41</u>

Vice President Lee moved adoption; Council Member Lindsay seconded.

President Foote recognized Fidelis Malembeka, Chief Financial Officer, who provided a brief overview of the larger claims.

Note: Council Members Grizzell and Lee left the meeting.

President Foote moved, seconded by Council Member Hartley to amend claims to add a payment to Mills, Scanlon, Dye and Pittman, Inc. in the amount of \$32,566.09. The motion prevailed by the following vote:

- Yeas – Banks, Foote and Hartley.
- Nays – Lindsay.
- Absent – Grizzell, Lee and Stokes.

Thereafter, President Foote, called for a vote of said item as amended:

ORDER APPROVING CLAIMS NUMBER 28781 to 28847 APPEARING AT PAGES 421 TO 451 INCLUSIVE THEREON, ON MUNICIPAL “DOCKET OF CLAIMS”, IN THE AMOUNT OF \$7,058,172.50 AND MAKING APPROPRIATIONS FOR THE PAYMENT THEREOF.

IT IS HEREBY ORDERED that claims numbered 28781 to 28847 appearing at pages 421 to 451, inclusive thereon in the Municipal “Docket of Claims”, in the aggregate amount of \$7,058,172.50

**REGULAR MEETING OF THE CITY COUNCIL
TUESDAY, MAY 9, 2023 10:00 A.M.**

are hereby approved for payment and said amount is expressly appropriated for the immediate payment thereof.

IT IS FURTHER ORDERED that there is appropriated from the various funds the sums necessary to be transferred to other funds for the purpose of paying the claims as follows:

FROM:	TO ACCOUNTS PAYABLE FUND
GENERAL FUND	2,015,841.78
SEIZURE & FORF PORP-FED	49,666.67
TECHNOLOGY FUND	31,005.48
PARKS & RECR. FUND	54,382.73
BUSINESS IMPROV FUND (LANDSCP)	58,645.87
LANDFILL/SANITATION FUND	809,534.29
STATE TORT CLAIMS FUND	102,899.38
WATER/SEWER REVENUE FUND	889.29
WATER/SEWER OP & MAINT FUND	1,284,163.06
WATER/SEWER CAPITAL IMPR FUND	36,474.82
DISABILITY RELIEF FUND	107,882.66
EMPLOYEES GROUP INSURANCE FUND	143,287.80
KELLOGG FOUNDATION PROJECT	40,833.33
HOUSING COM DEV ACT (CDBG) FD	20,486.55
UNEMPLOYMENT COMPENSATION REVO	36,302.23
HOME PROGRAM FUND	47.95
H O P W A GRANT – DEPT. OF HUD	104,340.28
INFRASTRUCTURE BOND 2020 \$32M	142,459.66
1% INFRASTRUCTURE TAX	10,982.48
TRANSPORTATION FUND	750,012.21
FONDREN BUSINESS IMPROV FUND	3,962.12
MHC BLIGHT ELIMINATION PROGRAM	27,750.06
SIEMENS SETTLEMENT ACCOUNT	454,045.94
ESG COVID CARES ACT	23,711.67
CDBG COVID CARES	39,418.62
ZOOLOGICAL PARK	38,133.02
LIBRARY FUND	171,704.16
DFA – SB2971 – LIVINGSTON PARK	15,000.00
DFA – SB2971 – PETE BROWN GOLF	63,331.00
DFA – THALIA MARA HALL \$2M	352,134.68
2022 GO PLANETARIUM BOND \$7.5M	32,250.00
BELHAVEN COMMUNITY IMPROVEMENT	4,026.62
TOTAL	<u>\$7,058,172.50</u>

- Yeas – Banks and Foote.
- Nays – Lindsay.
- Abstention – Hartley
- Absent – Grizzell, Lee and Stokes.

Note: Said item failed due to lack of a majority vote.

* * * * *

Note: Vice President Lee returned to the meeting.

* * * * *

President Foote recognized **Council Member Lindsay** who moved, seconded by **Council Member Hartley** to reconsider Claims. The motion prevailed by the following vote:

Yeas – Foote, Hartley and Lindsay.

Nays – Banks and Lee.

Absent – Grizzell and Stokes.

Thereafter, **President Foote** requested that the Clerk read the order as amended:

ORDER APPROVING CLAIMS NUMBER 28781 to 28847 APPEARING AT PAGES 421 TO 451 INCLUSIVE THEREON, ON MUNICIPAL “DOCKET OF CLAIMS”, IN THE AMOUNT OF \$7,058,172.50 AND MAKING APPROPRIATIONS FOR THE PAYMENT THEREOF.

IT IS HEREBY ORDERED that claims numbered 28781 to 28847 appearing at pages 421 to 451, inclusive thereon in the Municipal “Docket of Claims”, in the aggregate amount of \$7,058,172.50 are hereby approved for payment and said amount is expressly appropriated for the immediate payment thereof.

IT IS FURTHER ORDERED that there is appropriated from the various funds the sums necessary to be transferred to other funds for the purpose of paying the claims as follows:

FROM:	TO ACCOUNTS PAYABLE FUND
GENERAL FUND	2,015,841.78
SEIZURE & FORF PORP-FED	49,666.67
TECHNOLOGY FUND	31,005.48
PARKS & RECR. FUND	54,382.73
BUSINESS IMPROV FUND (LANDSCP)	58,645.87
LANDFILL/SANITATION FUND	809,534.29
STATE TORT CLAIMS FUND	102,899.38
WATER/SEWER REVENUE FUND	889.29
WATER/SEWER OP & MAINT FUND	1,284,163.06
WATER/SEWER CAPITAL IMPR FUND	36,474.82
DISABILITY RELIEF FUND	107,882.66
EMPLOYEES GROUP INSURANCE FUND	143,287.80
KELLOGG FOUNDATION PROJECT	40,833.33
HOUSING COM DEV ACT (CDBG) FD	20,486.55
UNEMPLOYMENT COMPENSATION REVO	36,302.23
HOME PROGRAM FUND	47.95
H O P W A GRANT – DEPT. OF HUD	104,340.28
INFRASTRUCTURE BOND 2020 \$32M	142,459.66
1% INFRASTRUCTURE TAX	10,982.48
TRANSPORTATION FUND	750,012.21
FONDREN BUSINESS IMPROV FUND	3,962.12
MHC BLIGHT ELIMINATION PROGRAM	27,750.06
SIEMENS SETTLEMENT ACCOUNT	454,045.94
ESG COVID CARES ACT	23,711.67
CDBG COVID CARES	39,418.62
ZOOLOGICAL PARK	38,133.02
LIBRARY FUND	171,704.16
DFA – SB2971 – LIVINGSTON PARK	15,000.00
DFA – SB2971 – PETE BROWN GOLF	63,331.00
DFA – THALIA MARA HALL \$2M	352,134.68

**REGULAR MEETING OF THE CITY COUNCIL
TUESDAY, MAY 9, 2023 10:00 A.M.**

157

2022 GO PLANETARIUM BOND \$7.5M	32,250.00
BELHAVEN COMMUNITY IMPROVEMENT	4,026.62
TOTAL	<u>\$7,058,172.50</u>

Yeas – Foote.
Nays – Banks, Hartley, Lee and Lindsay.
Absent – Grizzell and Stokes.

Note: Said item failed due to lack of a majority vote.

* * * * *

Note: Council Member Grizzell returned to the meeting.

* * * * *

ORDER APPROVING GROSS PAYROLL INCLUDING PAYROLL DEDUCTION CLAIMS NUMBERED 28732 TO 28745 AND MAKING APPROPRIATION FOR THE PAYMENT THEREOF.

IT IS HEREBY ORDERED that payroll deduction claims numbered 28732 to 28745 inclusive therein, in the Municipal “Docket of Claims”, in the aggregate amount of \$97,109.37 plus payroll, are approved for payment and necessary amounts are appropriated from various municipal funds for transfer to the payroll fund for the immediate payment thereof.

IT IS FINALLY ORDERED that the following expenditures from the accounts payable fund be made in order to pay amounts transferred thereto from the payroll fund for payment of the payroll deduction claims authorized herein for payment:

FROM:	TO ACCOUNTS PAYABLE FUND	TO PAYROLL FUND
GENERAL FUND		2,269,483.16
PARKS & RECR FUND		102,077.39
LANDFILL FUND		18,418.22
SENIOR AIDES		3,440.23
WATER/SEWER OPER & MAINT		186,238.52
PAYROLL	97,109.37	
HOUSING COMM DEV		8,506.36
TITLE III AGING PROGRAMS		5,974.20
TRANSPORTATION FUND		18,213.44
PEG ACCESS-PROGRAMMING FUND		5,465.01
2020 SAKI GRAND DOJ		7,405.71
ZOOLOGICAL PARK		28,745.96
AMERICAN RESCUE PLAN ACT 2021		10,427.45
NLC-MUNICIPAL REIMAGINING COMM		3,627.77
TOTAL		\$2,668,023.42

Vice President Lee moved adoption; **Council Member Hartley** seconded.

Yeas – Banks, Foote, Grizzell, Hartley, Lee and Lindsay.
Nays – None.
Absent – Stokes.

* * * * *

ORDER AUTHORIZING THE MAYOR TO EXECUTE AN AGREEMENT WITH FIRST MEA PRIMARY CARE PLUS, LCC D/B/A MEA CARES EMPLOYEE ASSISTANCE PROGRAM.

WHEREAS, Section 25-15-101 of the Mississippi Code authorizes the governing authorities of a municipality to negotiate and secure for its employees and their dependents contracts for health, hospitalization, medical, surgical and other benefits; and

WHEREAS, First MEA Primary Care Plus, LLC d/b/a MEA Cares has available an Employee Assistance Program capable of providing counseling services to employees on issues, including but not limited to, stress management, grief, anxiety, alcohol, substance abuse, or marital issues; and

WHEREAS, the services provided by MEA Cares Employee Assistance Program relate to an individual's mental health; and

WHEREAS, contracting with First MEA Primary Care Plus LLC d/b/a MEA Cares to provide assistance to municipal employees challenged with personal or familiar issues affecting mental health serves the best interest; and

WHEREAS, the assistance afforded by the program will be confidential; and

WHEREAS, MEA Cares will provide a toll-free confidential Employee Assistance line with twenty-four (24) hour access for City of Jackson, Mississippi employees and their covered family members; and

WHEREAS, after hours face-to-face meetings with a counselor in the case of an emergency defined as homicidal, suicidal, or actively psychotic will also be available; and

WHEREAS, MEA Cares submitted a proposal containing three (3) plan options as follows:

Option A: Three (3) sessions per employee and per covered family member at a cost of \$2,000 per month for a total of \$24,000 per contract year; and

Option B: Four (4) sessions per employee and per covered family member at a cost of \$2,688.00 per month for a total of \$32,256 per contract year; and

Option C: Five (5) sessions per employee and per covered member at a cost of \$3,600.00 per month for a total of \$43,200 per contract year; and

WHEREAS, covered family member is defined as spouse and unmarried children or step-children living at home or in school full-time under the age of 26 and residing in the state of Mississippi; and

WHEREAS, referral for treatment (when appropriate and available) will be made in accordance with the preferred provider network of the City of Jackson, Mississippi; and

WHEREAS, MEA Cares will provide Unlimited on-site critical incident stress debriefing per contract year available within forty-eight hours following an in-house crisis or a community crisis involving City of Jackson, Mississippi employees; and

WHEREAS, the Department of Human Resources recommends that the governing authorities enter in a contract with First MEA Primary Care Plus, LLC to provide services consistent with Option A; and

WHEREAS, the sessions will be provided by licensed professionals with a minimum of a Master's degree in social work, counseling, marriage and family, or psychology; and

WHEREAS, the counseling sessions will occur at the office(s) of the respective therapist and will be located within 65 miles of the covered employee's workplace; and

WHEREAS, employees and covered family members will be provided with written notification of the City of Jackson's sponsored benefit referred to as the Employee Assistance Program (EAP); and

WHEREAS, employees and covered dependents will be informed of the various services offered; and

WHEREAS, participation in the program will be voluntary and kept confidential; and

WHEREAS, management and supervisors will not receive information concerning an employee's participation unless a formal release of information is signed by the employee; and

WHEREAS, the City will be required to designate a representative to act as liaison to MEA in the administration of the program; and

WHEREAS, MEA Cares will develop and provide to the City of Jackson brochures and a User Guide; and

WHEREAS, MEA Cares will prepare and submit a monthly statistical report on EAP utilization to a representative of the City of Jackson, Mississippi including number of EAP calls, referrals, number of admissions to outpatient therapy and number of counseling sessions; and

WHEREAS, the monthly reports will not contain identifying information on the employee or covered family member; and

WHEREAS, the term of the Agreement will be for a period of three (3) years from the date executed and will be renewed for successive annual periods unless either party provides notice of intent to terminate to the other 60 days in advance of the date of termination; and

WHEREAS, neither MEA nor the City shall assign its duties and responsibilities under the Agreement without the prior consent of the other party; and

WHEREAS, the Agreement may be modified only by a written consent amendment signed by representatives of the City and MEA.

IT IS HEREBY ORDERED that the Mayor is authorized to execute a contract with First MEA Primary Care Plus, LLC d/b/a MEA Cares for the offering of the Employee Assistance Program benefit.

IT IS HEREBY ORDERED that a sum not exceeding \$2,000.00 per month or \$24,000.00 per year may be paid for the program benefits.

IT IS HEREBY ORDERED that the agreement may be renewed after the initial three (3) year term for successive one (1) year terms provided that the terms of the agreement remain unchanged.

IT IS HEREBY ORDERED that the Mayor shall be authorized to designate an individual who will be liaison for the City and receive the monthly statistical report.

Council Member Grizzell moved adoption; **Vice President Lee** seconded.

Yeas – Foote, Grizzell, Hartley, Lee, Lindsay.
Nays – Banks.
Absent – Stokes.

* * * * *

ORDER AUTHORIZING THE MAYOR TO EXECUTE AN AGREEMENT WITH WISE STAFFING SERVICES INC. TO PROVIDE TEMPORARY STAFFING SERVICES TO VARIOUS CITY DEPARTMENTS.

WHEREAS, the City of Jackson has a need for temporary staffing services for various City Departments; and

WHEREAS, the Department of Human Resources is responsible for securing temporary staffing services for all City Departments; and

WHEREAS, representatives from City Departments will notify the Department of Human Resources when they are in need of temporary staffing services; and

WHEREAS, the Department of Human Resources sends a request to temporary agencies when there is a need for services; and

WHEREAS, the request includes the requesting Department, classification title, duties, quote and schedule; and

WHEREAS, the Department of Human Resources selects the agency with the lowest quote; and

WHEREAS, Wise Staffing Services Inc. will provide the City of Jackson on request with qualified temporary staffing services for the classification specifications; and

WHEREAS, Wise Staffing Services Inc. has an office located at 432 Magazine Street, Tupelo, Mississippi; and

WHEREAS, Wise Staffing Services Inc. submitted a rate sheet for the temporary positions provided to the City of Jackson as follows:

Position	Pay Rate	Bill Rate
Communications Clerk	\$11.63	\$16.23
Public Safety Dispatcher	\$13.30	\$18.62
Records Clerk	\$9.89	\$13.85
Data Entry Clerk	\$9.89	\$13.85
Custodian, Janitorial, House Keeping	\$9.89	\$13.85
Golf Course Attendant	\$9.70	\$13.58
Zoo Keeper	\$12.72	\$17.81
Maintenance Worker/General Labor	\$12.50	\$17.50
Clerical	\$14.00	\$19.60

WHEREAS, Wise Staffing Services Inc. will submit time sheets documenting the time worked and invoices to the City for services performed by assigned employees on a weekly basis, and the City will remit payment within 30-45 days consistent with the statute for timely payment by governmental entities; and

WHEREAS, invoices will be supported by the Wise Staffing Services Inc., Timesheets for assigned employees; and

WHEREAS, the signature of the City of Jackson on the Timesheet certifies that the documented hours are correct and authorizes Wise Staffing Services, Inc to bill The City of Jackson for those hours; and

WHEREAS, the term of the contract will be 24 months (2) years from the date of execution of the agreement; and

WHEREAS, Wise Staffing Services Inc. will recruit, screen, interview, hire, and assign its employees to perform the work under the supervision of the City of Jackson and will be responsible for paying the assigned employees' wages and provide them with the benefits Wise Staffing Services Inc. offers to them; and

WHEREAS, Wise Staffing Services Inc. will pay, withhold, and transmit payroll taxes, provide unemployment insurance and workers compensation benefits and handle unemployment and workers' compensation claims involving the assigned employees; and

WHEREAS, Wise Staffing Services Inc. will comply with federal, state and local labor and employment laws applicable to assigned employees including the Immigration Reform and Control Act of 1986, the Internal Revenue Code, the Employee Retirement Income Security Act, the Health Insurance Portability and Accountability Act, the Family Medical Leave Act, Title VII of the Civil Rights Act of 1964, the American with Disabilities Act, the Fair Labor Standards Act, the Consolidated Omnibus Budget Reconciliation Act, the Uniformed Services Employment and Reemployment Rights Act of 1994, and the Patient Protection and Affordable Care Act; and

WHEREAS, Wise Staffing Services Inc. will comply with all provisions of the Affordable Care Act applicable to assigned employees, including the employer shared responsibility provisions related to the offer of minimum essential coverage to "full-time" employees as those terms are defined in the United States Code and related regulations and the applicable employer information reporting provisions set forth in the United States Code and related regulations; and

WHEREAS, Wise Staffing Services Inc. will have the right to physically inspect the work site and work processes to review and address unilaterally or in coordination with the City work performance issues of the assigned employee and to enforce Wise Staffing Services Inc. employment policies related to the assigned employees conduct at the worksite; and

WHEREAS, the City will properly supervise the assigned employee performing its work and be responsible for its business operations, products, services, and intellectual property; and

WHEREAS, the City will supervise, control, and safeguard its premises, processes, or systems and not permit assigned employees to operate any vehicle or mobile equipment or entrust them with unattended premises, cash, checks, keys, credit cards, merchandise, confidential or trade secret information, negotiable instruments, or other valuables without Wise Staffing Services Inc. express prior written approval or as strictly required by the job description provided to Wise Staffing Services Inc.; and

WHEREAS, the City will not change the assigned employees job duties without Wise Staffing Services Inc. express prior written approval; and

WHEREAS, the City will exclude assigned employees from its benefit plans, policies, and practices and not make any offer or promise relating to the assigned employee's compensation and benefits; and

WHEREAS, the City and Wise Staffing Services Inc. agree to hold confidential information in strict confidence and not disclose the information to third parties or use the information for any purpose other than performing the Agreement as required; and

WHEREAS, knowledge, possession or use of the City's information will not be imputed to Wise Staffing Services Inc. as a result of an assigned employee having access to the information; and

WHEREAS, the terms of the agreement will be considered severable, such that if any provision or clause which conflicts with existing or future law or may not be given full effect because of the law, no other provision that can operate without the conflicting provision or clause will be affected; and

WHEREAS, neither party will be responsible for failure or delay in performance of the agreement if the delay in performance is due to labor disputes, strikes, fire, riot, war, terrorism, Acts of God or other causes beyond the control of the nonperforming party; and

WHEREAS, Wise Staffing Services Inc. will provide proof of liability and workers compensation coverage upon request of the City.

IT IS HEREBY ORDERED that the Mayor be authorized to execute a contract with Wise Staffing Services Inc. for the purposes stated in this Order.

IT IS FURTHER ORDERED that the Mayor, or his designee, be authorized to execute any and all documents necessary to implement the contract described in this Order.

IT IS FURTHER ORDERED that payment for the services provided after the contract has been executed may be made to Wise Staffing Services Inc.

Vice President Lee moved adoption; **Council Member Lindsay** seconded.

Yeas – Foote, Grizzell, Hartley, Lee, Lindsay.

Nays – Banks.

Absent – Stokes.

* * * * *

ORDER AUTHORIZING THE MAYOR TO EXECUTE A FORTY-EIGHT MONTH (4yr) RENTAL AGREEMENT WITH ADVANTAGE BUSINESS SYSTEMS FOR AMINOLTABIZHUB C300i DIGITAL COLOR SYSTEM AND THE MINOLTA BIZHUB 360i (BLACK/WHITE) DIGITAL COLOR SYSTEM TO BE USED BYTHE DEPARTMENT OF HUMAN RESOURCES.

WHEREAS, Section 31-7-13(m)(i) of the Mississippi Code exempts from bidding requirements purchasing agreements, contracts, and maximum price regulations executed or approved by the Department of Finance and Administration; and

WHEREAS, Advantage Business Systems is authorized by State Contract # 8200062059 to furnish copier equipment and supplies; and

WHEREAS, the Department of Human Resources has need for copying equipment and supplies and has identified the Minolta Bizhub C300i Digital Color System and a Minolta Bizhub 360i Black and White Digital System as being sufficient to meet its needs; and

WHEREAS, the terms of the agreement with Advantage Business Systems are set for in State Contract #8200062059 dated February 2017; and

WHEREAS, the term of the lease of the equipment will be for a period of forty-eight (48) months and no automatic renewal will be allowed; and

WHEREAS, another agreement will be required if the City of Jackson desires to continue leasing the equipment; and

WHEREAS, Advantage Business Systems will install, maintain, and repair the equipment to keep in good working order; and

WHEREAS, Advantage Business Systems will provide one copy credit for copy which the City deems unusable and for copies produced during servicing of the equipment; and

WHEREAS, Advantage Business Systems will to the maximum extent permitted by law indemnify, defend, and hold harmless the City, its officers, employers, and agents against all claims, demands, liabilities, suits, action, damage, losses and costs of any kind and nature caused by Advantage Business System in performance of or failure to perform the agreement; and

WHEREAS, Advantage Business Systems must use legal counsel acceptable to the City in defending a suit, if it controls the defense; and

WHEREAS, Advantage Business Systems shall not settle any claim, suit, or action with concurrence from the City; and

WHEREAS, the cost of the Minolta Bizhub C300i Digital Color System is \$165.00 per month plus a per copy charge of .0085 for all copies; and

WHEREAS, the cost of the Minolta Bizhub 360i Black and White System is \$123.00 per month plus a per copy charge of .0079 for copies; and

WHEREAS, labor, parts, toner and drums with the exception of staples and paper are included in the price of the equipment rental.

IT IS HEREBY ORDERED that the Mayor shall be authorized to execute a contract with Advantage Business System for the rental of a Minolta Bizhub C300i copier at a cost of \$165.00 per month plus a per copy charge of .0085 per copy and for the rental of a Minolta Bizhub 360i at a cost of \$123.00 per month plus a per copy charge of .0079 per copy.

IT IS HEREBY ORDERED that payment for the rental of the equipment and the copy charges may be made from budgeted funds of the Department of Human Resources.

Vice President Lee moved adoption; **Council Member Grizzell** seconded.

Yeas – Banks, Foote, Grizzell, Hartley, Lee and Lindsay.

Nays – None.

Absent – Stokes.

* * * * *

ORDER AUTHORIZING THE SOLE SOURCE PROCUREMENT OF TWENTY-FIVE (25) GUARDIAN HANDHELD LAUNCHING SYSTEMS AND ALSO TWENTY-FIVE (25) TWELVE MONTH SUBSCRIPTIONS TO GPS LIVE TRACKING PROJECTILES, COREVIEW MAPPING, DATA AND USE ACCESS FOR FOUR YEARS AND ONE TRAIN THE TRAINER MODULE FOR APERIOD OF FOUR (4) YEARS AND AUTHORIZING THE MAYOR TO EXECUTE A CONTRACT WITH STAR CHASE, LLC RELATED TO THE SUBSCRIPTIONS.

WHEREAS, Starchase, LLC has a patent on a handheld real time vehicle tagging and tracking technology product which may be used by law enforcement as a safe alternative to high-speed pursuits; and

WHEREAS, the Jackson Police Department received undated correspondence from Trevor A. Fischbach, the President of StarChase LLC advising that it is the exclusive and sole manufacturer of the handheld tagging and tracking technology product; and

WHEREAS, the correspondence from StarChase also indicated that its technology is a patented product and its unique characteristics make it a stand-alone product in electronic/surveillance, law enforcement vehicle/traffic accessories and pursuit management; and

WHEREAS, the Jackson Police Department has been able to locate a company with a similar product offering with the capacity to tag and track in real time; and

WHEREAS, Section 31-7-13 (m)(viii) of the Mississippi Code exempts from bidding requirements non-competitive items available from one (1) source only; and

WHEREAS, Section 31-7-13(m)(viii) the governing authorities for the City of Jackson have the power to authorize the purchase of non-competitive items when the conditions and circumstances requiring the purchase are known; and

WHEREAS, the Guardian-HX Handheld Launcher manufactured by Star Chase, LLC is only available from Star Chase LLC; and

WHEREAS, the Guardian-HX Handheld Launcher may be applied in auto theft recovery, special operations, DUI checkpoints, barricaded suspects, patrol operations, and interdiction of law enforcement agencies; and

WHEREAS, the City of Jackson is an urban area where high speed law enforcement pursuits pose significant risk of death and severe bodily injury; and

WHEREAS, the Guardian-HX Handheld Launcher is cutting edge technology which will be useful in reducing the risk of death and severe bodily injury from police pursuits while simultaneously assisting with the capture of criminal of criminal suspects; and

WHEREAS, the Jackson Police Department recommends that the governing authorities authorize the purchase of twenty (25) Guardian-HX Handheld Launchers at the cost of \$82,612.00 after application of a \$12,388.00 discount and includes the Pelican 1720 rifle case, battery mags and charger, training rounds and live GPS rounds; and

WHEREAS, a subscription to the GPS Live Tracking Projectiles, Coreview, and Mapping Data is required for the use of the Guardian-HX Handheld Launcher; and

WHEREAS, twenty-five (25) one (1) year subscriptions to the GPS Live Tracking Projectiles and Mapping Data cost \$11,400.00 after application of a discount of \$600.00; and

WHEREAS, StarChase has offered an opportunity to renew the subscriptions for three twelve-month periods after the initial subscription year at a cost of \$11,400.00; and

Whereas, the terms and conditions of the agreement with StarChase are as follows:

- (1) The products will be of genuine and authentic manufacture and new and unused;

- (2) All maintenance services including updates and software upgrades will be in a professional manner by qualified personnel;
- (3) StarChase hardware will be free from manufacturing defects and will be in good operating condition in accordance with publicly available written specifications in effect at the time of delivery during StarChase's one year warranty period for the StarChase hardware; and
- (4) StarChase shall issue a separate invoice for each order containing the following information:
 - (a) description and quantity of products ordered;
 - (b) the quantity of products shipped;
 - (c) delivery destination and day/date confirming product delivery;
 - (d) purchase order number;
 - (e) purchase price for each product;
 - (f) total purchase price for purchase order;
 - (g) applicable taxes, freight charges and applicable discounts;
- (5) All invoiced amounts shall be subject to a two percent (2%) (early payment discount for payments remitted within fifteen (15) days of receipt of invoice;
- (6) Any payment which is past due and caused by reasons attributable to City will be subject to a monthly charge at the rate of one- and one-half percent (1.5) per month of the amount due or the maximum rate permitted by law, whichever is lower;
- (7) If there is a dispute arising out of the agreement, the prevailing party shall be entitled to recover its attorney's fees and cost, including at trial and on appeal and in any action brought solely to recover attorneys' fees and costs to which it is entitled.

WHEREAS, in addition to the GPS Live Tracking Projectiles and Mapping Data, StarChase provides an Interactive Web based Operator Train the Trainer Module at a cost of \$420.00; and

WHEREAS, the best interest of the City of Jackson would be served by authorizing the purchase of Interactive Web based Operator Train the Trainer Module at \$420.00; and

WHEREAS, the best interest of the City of Jackson would be served by authorizing the purchase of a twelve-month subscription to the GPS Live Tracking Projectiles and Mapping Data program at the discounted cost of \$11,400.00; and

WHEREAS, the best interest of the City of Jackson would be served by authorizing the renewal of the GPS Live Tracking Projectiles and Mapping Data program at the discounted cost of \$11,400.00; and

WHEREAS, the best interest of the City of Jackson would be served by authorizing the renewal of the GPS Live Tracking Projectiles and Mapping Data for three (3) additional years at the discounted cost of \$11,400.00 following the expiration of the initial subscription year.

IT IS, THEREFORE, ORDERED that 25 Guardian Handheld Launchers may be purchased from StarChase at a cost of \$82,612.00.

IT IS, THEREFORE, ORDERED that 25 twelve-month subscriptions of the GPS Live Tracking Projectiles, Coreview, Mapping and Data service.

IT IS, THEREFORE, ORDERED that subsequent to the expiration of the initial twelve-month subscription of the GPS Live Tracking Projectiles, Coreview, Mapping and Data services, the subscription may be renewed for three additional one-year periods at the same discounted cost of \$11,400.00 annually.

IT IS, THEREFORE, ORDERED that payment for the renewal subscription of the GPS Live Tracking Projectiles Coreview Mapping and Data service shall be made at the time that the subscription requires review and not prior to the renewal period.

IT IS, THEREFORE, ORDERED that the total sum which may be paid for the initial purpose of the Handheld Launchers, GPS Live Tracking Projectiles, Coreview Mapping and Data Service, and Training Module shall not exceed the sum of \$95,808.00 which includes shipping of \$1,376.00.

IT IS, THEREFORE, ORDERED that the Mayor shall be authorized to execute the agreement with StarChase related to the procurement of the goods and the subscriptions.

IT IS, THEREFORE, ORDERED that the Mayor shall be authorized to execute agreements related to the subscription service when each renewal period occurs without further order of the Jackson City Council. No advance agreement to renew the subscription services is authorized.

Vice President Lee moved adoption; **Council Member Lindsay** seconded.

Yeas – Banks, Foote, Grizzell, Hartley, Lee and Lindsay.

Nays – None.

Absent – Stokes.

* * * * *

Note: Council Member Banks and **Council Member Hartley** left the meeting.

* * * * *

ORDER AUTHORIZING THE MAYOR OF THE CITY OF JACKSON TO EXECUTE AN MOU WITH THE MISSISSIPPI DEPARTMENT OF MENTAL HEALTH BUREAU OF BEHAVIORAL HEALTH SERVICES WHICH WILL ENABLE THE JACKSON POLICE DEPARTMENT TO RECEIVE, DISTRIBUTE, AND ADMINISTER NARCAN.

WHEREAS, Section 21-17-5 of the Mississippi Code authorizes the governing authorities of a municipality to adopt any orders with respect to municipal affairs which is not inconsistent with the Mississippi Constitution of 1890; and

WHEREAS, protecting the health and safety of persons within the municipality is a function of the Jackson Police Department and constitutes a municipal affair; and

WHEREAS, the Mississippi Department of Mental Health Bureau of Behavioral Health Services is a state instrumentality with access to the nasal spray – Narcan; and

WHEREAS, Narcan is also known as Naloxone and has been known to be effective in reducing the effects of opioid overdoses; and

WHEREAS, the Mississippi Department of Mental Health Bureau of Behavioral Health has the authority to supply law enforcement and public safety personnel with Narcan at no cost; and

WHEREAS, the Mississippi Department of Mental Health Bureau of Behavioral Health Services is amenable to supplying the Jackson Police Department with Narcan upon execution of an MOU; and

WHEREAS, the Jackson Police Department recommends that the City of Jackson enter into an MOU with the Mississippi Department of Mental Health’s Bureau of Behavioral Health to facilitate the supplying of Narcan; and

WHEREAS, having access to Narcan will enable officers of the Jackson Police Department to minimize the risk of death when called to respond to opioid overdoses; and

WHEREAS, pursuant to the terms of the MOU, the Department of Mental Health will provide units of Narcan to the Jackson Police Department monthly; and

WHEREAS, the Department of Mental Health will provide electronic and paper forms for tracking the supply of Narcan and capturing data related to the distribution and deployment of Narcan; and

WHEREAS, the Department of Mental Health will provide online or in person training on the proper administration and storage of the Narcan to personnel determined by the Jackson Police Department prior to the delivery of the Narcan; and

WHEREAS, the City of Jackson must attest to the training of agency personnel prior to personal possession of the NARCAN; and

WHEREAS, the City of Jackson through its police department must monitor agency personnel in possession of Narcan for adherence to the proper safeguarding and storage of the inventory including but not limited to the following guidelines:

Store at room temperature between 59 degrees Fahrenheit to 77 degrees Fahrenheit (15 degrees Celsius to 25 degrees Celsius);
Do not freeze Narcan;
Keep the Narcan in its box until ready for use to protect from light;
Replace the Narcan before the expiration date on the box;
Keep it and all medicines out of the reach of children

WHEREAS, the City of Jackson must designate an individual to be a Point of Contact for the purpose of completing and delivering the monthly Narcan Reporting form; and

WHEREAS, the monthly Narcan Reporting Form must be delivered by electronic mail by the 10th day of each month to Maggie.Roberts@dmh.ms.gov whose telephone number is 601-359-6221; and

WHEREAS, the City of Jackson through its police department must distribute Narcan to agency personnel as necessary to ensure that the first-in-first out inventory management is followed to reduce inventory loss arising out of product expiration; and

WHEREAS, the MOU will be effective for the lesser of two (2) years from the date of execution or until the NARCAN inventory is depleted; and

WHEREAS, the MOU may be terminated by the Department of Mental Health in its discretion along with a return of all remaining NARCAN inventory if the monthly reporting form becomes more than 90 days delinquent; and

WHEREAS, 14 days advance notice will be provided if there is early termination, and the Point of Contact shall be responsible for obtaining all returning inventory and delivery to: Chuch Oliphant, Bureau of Behavioral Health Services, 239 North Lamar Street, 1101 Robert E. Lee Building, Jackson, Mississippi.

IT IS HEREBY ORDERED that the Mayor shall be authorized to execute the MOU with the Mississippi Department of Mental Health pertaining to the delivery and distribution of NARCAN.

Vice President Lee moved adoption; **Council Member Lindsay** seconded.

Yeas – Foote, Grizzell, Lee and Lindsay.

Nays – None.

Absent – Banks, Hartley and Stokes.

* * * * *

ORDER AUTHORIZING THE MAYOR TO TERMINATE AN ADDENDUM TO THE LICENSE AND SERVICE AGREEMENT IT TYLER TECHNOLOGIES, INC. FOR THE TYLER NEW WORLD PUBLIC SAFETY PRODUCTS, LICENSES, SOFTWARE, AND SERVICES.

WHEREAS, the Information System Division for the Department of Information Technology recommended that the Jackson Police Department utilize Tyler Technologies Inc.'s ("TylerTech") New World Public Safety system to replace legacy systems for Fire, Police and 91 1; and

WHEREAS, on October 29, 2019, the Jackson City Council authorized the Mayor to execute an addendum to the Tyler Technologies, Inc. Agreement for additional software, hardware, and implementation services for the Enterprise Resource Planning System: and

WHEREAS, the Department of Information Technology and the Jackson Police Department recommend that the governing authorities for the City of Jackson authorize the Mayor to terminate the Addendum to the License and Service Agreement with TylerTech for the Tyler New World Public Safety products, licenses, software, and services; and

WHEREAS, the License and Service Agreement between the City of Jackson and Tyler Technologies, Inc. provides that if the City of Jackson believes TylerTech materially breached the Agreement, the City will invoke the Dispute Resolution clause set forth in the Agreement. The City of Jackson may terminate this Agreement for cause in the event TylerTech does not cure, or cause a mutually agreeable action plan to address, a material breach of this Agreement within the thirty (30) day window set forth in the Dispute Resolution clause; and

WHEREAS, in the event of termination for cause, the City will pay TylerTech for all undisputed fees and expenses related to the software, products, and/or services the City has received or TylerTech has incurred or delivered prior to the effective date of termination; and

WHEREAS, under the Dispute Resolution clause, the City of Jackson will provide written notice within thirty (30) days of becoming aware of dispute; and

WHEREAS, pursuant to said Agreement, the City of Jackson must cooperate in trying to reasonably resolve all disputes, including, if requested by either party; and

WHEREAS, the City of Jackson must appoint a senior representative to meet and engage in good faith negotiations with TylerTech's appointed senior representative; and

WHEREAS, senior representatives will convene within thirty (30) days of the written dispute notice, unless otherwise agreed; and

WHEREAS, if the parties fail to resolve the dispute, then the parties shall participate in non-binding mediation, then either of the parties may assert their respective rights and remedies in a court of competent jurisdiction; and

WHEREAS, the Department of Information Technology and the Jackson Police Department recommends to the governing authorities for the City of Jackson that the Mayor be authorized to provide TylerTech with written notice of a dispute regarding the Tyler New World Public Safety products, licenses, software, and services.

IT IS, THEREFORE, ORDERED that the Mayor is authorized to terminate the Addendum to the License and Software Agreement with TylerTech. for the Tyler New World Public Safety products, software, and services.

IT IS FURTHER ORDERED that the Jackson Police Department and the Department of Information Technology are authorized to pay TylerTech for all undisputed fees and expenses related to the software, products, and/or services the City has received or TylerTech has incurred or delivered prior to the effective date of termination.

Council Member Grizzell moved adoption; **Council Member Lindsay** seconded.

Yeas – Foote, Grizzell, Lee and Lindsay.

Nays – None.

Absent – Banks, Hartley and Stokes.

* * * * *

Note: Council Member Banks and Council Member Hartley returned to the meeting.

* * * * *

ORDER AUTHORIZING THE REVISION OF THE DEPARTMENT OF PLANNING AND DEVELOPMENT'S FISCAL YEAR 2023 BUDGET TO MOVE FUNDS ACROSS CATEGORIES FOR THE EMERGENCY SOLUTIONS CARES ACT GRANT PROGRAM YEAR 2023.

WHEREAS, the Mississippi Code Annotated, Section 21-35-25, states, if it affirmatively appears at any time during the current fiscal year that there is in any fund or account any sum remaining unexpended and not needed or expected to be needed for the purpose or purposes for which appropriated in said budget, then the governing authorities may, in their discretion, transfer such sum or any part thereof to any other fund or funds or account or accounts where needed; and

WHEREAS, there is an account line item in the Office of Housing and Community Development budget requiring Council approval to be moved across categories for the Emergency Solutions CARES Act Grant program year 2023; and

WHEREAS, the following funds would be revised as follows:

**REGULAR MEETING OF THE CITY COUNCIL
TUESDAY, MAY 9, 2023 10:00 A.M.**

168

To/From	Fund/Account Number	Amount
From:	0379.71513.6742 (Stewpot ESG-CV)	\$39,060.76
To:	0379.71511.6115 (Redistributed Salary ESG-CV)	\$39,060.76

IT IS, THEREFORE, ORDERED that the Department of Planning and Development’s Fiscal Year 2023 budget be revised for the Emergency Solutions CARES Act Grant program year 2023 funds in the amount of \$39,060.76 as follows:

To/From	Fund/Account Number	Amount
From:	0379.71513.6742 (Stewpot ESG-CV)	\$39,060.76
To:	0379.71511.6115 (Redistributed Salary ESG-CV)	\$39,060.76

Vice President Lee moved adoption; **Council Member Grizzell** seconded.

Yeas – Banks, Foote, Grizzell, Hartley, Lee and Lindsay.

Nays – None.

Absent – Stokes.

* * * * *

ORDER RATIFYING THE SUBMISSION OF AN APPLICATION TO THE MISSISSIPPI DEPARTMENT OF TRANSPORTATION’S MULTI-MODAL TRANSPORTATION IMPROVEMENT PROGRAM FOR FUNDING IN THE AMOUNT OF \$480,000.00 FOR THE SUPPORT OF JTRAN OPERATIONS.

WHEREAS, the Mississippi Department of Transportation published on its website notice for Section 5311 and Section 5307 recipients that the Mississippi Department of Transportation was making 16% of the Multi-Modal Transit Improvement Program (MMTIP) allocated funds available for transit projects; and

WHEREAS, the deadline for submitting an application was 4:00 p.m. on March 31, 2023; and

WHEREAS, the purpose of the Multi-Modal Transit Improvement Program is to provide funds for priority projects which funds are not otherwise available that are important to the continued development and improvement of the state’s public transportation infrastructure and have significant impact on local communities; and

WHEREAS, the funds cannot be used for routine administrative expenses; and

WHEREAS, the Mississippi Department of Transportation stated that funds will be approved on a competitive basis and not based on the number of applications received; and

WHEREAS, the City of Jackson has in previous years received an allocation or been awarded funds from the MMTIP; and

WHEREAS, the City of Jackson’s Transit Division recommends that the City of Jackson ratify the application submitted for the sum of \$480,000.00 to the Mississippi Department of Transportation in order to support fueling and other operating expenses not eligible for funding provided by the Federal Transit Administration; and

WHEREAS, the City of Jackson’s Transit Division believes that its application will be competitive and considered as a priority project; and

WHEREAS, the best interest of the City of Jackson would be served by applying for funding in the amount of \$480,000.00.

IT IS, THEREFORE, ORDERED that the application submitted to the Mississippi Department of Transportation MMTIP for funding in the amount of \$480,000.00 is ratified.

IT IS FURTHER ORDERED that if funds are awarded to the City of Jackson by the Mississippi Department of Transportation, the Mayor shall be authorized to accept the funds received, execute documents and agreements required for receipt of funds and submit financial reports concerning the receipt and expenditure of the monies.

Council Member Hartley moved adoption; **Vice President Lee** seconded.

Yeas – Banks, Foote, Grizzell, Hartley, Lee and Lindsay.

Nays – None.

Absent – Stokes.

* * * * *

ORDER AUTHORIZING THE MAYOR TO EXECUTE AN AMENDMENT, CHANGE ORDERS #1-4 AND RELATED DOCUMENTS TO THE AGREEMENT WITH GCW PAVEMENT SERVICES TO COMPLETE THE BUS STOP IMPROVEMENT PROGRAM OF THE JACKSON PUBLIC TRANSPORTATION SYSTEM (JTRAN).

WHEREAS, the City of Jackson, Mississippi (“City”), determined that it was in the City’s best interest to seek a construction company for the bus stop improvement project of the City’s public transit system; and

WHEREAS, on March 22, 2022, Minute Book 6U, pages 555-556, the governing authorities authorized the Mayor to execute an agreement with GCW Pavement Services to provide construction of the bus stop improvement project at a total cost not to exceed four hundred seventy-two thousand fifty-three dollars and one cent (\$472,053.01); and

WHEREAS, on December 6, 2022, Minute Book 6W, pages 425-426, the governing authorities authorized the Mayor to extend the agreement to March 31, 2023 with GCW Pavement Services to provide construction of the bus stop improvement project at a total cost not to exceed four hundred seventy-two thousand fifty-three dollars and one cent (\$472,053.01); and

WHEREAS, due to additional unforeseen site work, Transit Services is requesting an extension to the contract through June 30, 2023; and

WHEREAS, during construction, multiple issues were identified that require a change order to correct; and

WHEREAS, Change Orders #1-4 resulted in an increased amount not to exceed twenty-two thousand six hundred twelve dollars and twenty-seven cents (\$22,612.27); and

WHEREAS, for all work to be completed in accordance with the contract documents, minor modifications to the existing plans were required and description of each change listed below; and

Change Order#1: This was necessary due to extra work required at the UMMC location on North State Street (east side) in order for the shelter pad and sidewalk to meet slop tolerances (\$5,822.23).

Change Order#2: This was necessary due to extra work required at the Wal-Mart site due to unstable soil conditions (\$6,750.91).

Change Order#3: This was necessary due to extra work required at the Fortification Street site on North State to provide for modification to accommodate wheelchair access (\$4,189.13).

Change Order#4: This was necessary due to extra work required at the base of the column posts and brace posts (\$5,850.00).

IT IS, THEREFORE, ORDERED that the governing authorities hereby authorizes the Mayor to execute an amendment, change orders#1-4 and related documents to the agreement with GCW Pavement Services increasing the contract by an amount not to exceed twenty-two thousand six hundred twelve dollars and twenty-seven cents (\$22,612.27) with eighty percent (80%) of the cost or eighteen thousand eighty-nine dollars and eighty-two cents (\$18,089.82) to be paid by the Federal Transit Administration and twenty percent (20%) or four thousand five hundred twenty-two dollars and forty-five cents

(\$4,522.45) from local match from FY2023 Transit Budget and extending the contract period to June 30, 2023.

Vice President Lee moved adoption; Council Member Hartley seconded.

Yeas – Banks, Foote, Grizzell, Hartley, Lee and Lindsay.

Nays – None.

Absent – Stokes.

* * * * *

ORDER AUTHORIZING THE MAYOR TO EXECUTE A LEASE AND RELATED DOCUMENTS WITH WESTLAND SHOPPING CENTER, L.P. TO LEASE OFFICE SPACE FOR THE JACKSON POLICE DEPARTMENT, POLICE PRECINCT NO. 2.

WHEREAS, the Jackson Police Department, Precinct No. 2 is currently housed in the Metrocenter Mall; and

WHEREAS, the Metrocenter Mall is in a consistent state of disrepair, and Precinct No. 2 is in need of an alternate location; and

WHEREAS, the Jackson Police Department recommends to the governing authorities for the City of Jackson that the Mayor be authorized to execute a Lease agreement with Westland Shopping Center, L.P., represented by its General Partner, Westland SC GP, Inc., having an address at c/o Stirling Properties, LLC, 109 Northpark Boulevard, Suite 300, Covington, Louisiana 70433 (“Landlord”) to relocate Precinct No. 2 to the Westland Plaza Shopping Center located at the corner of Ellis Avenue and Robinson Road; and

WHEREAS, the Jackson Police Department proposes that the City enter into a 60-month lease that will automatically renew for 60 months in month 61, under the same terms and conditions, unless the City of Jackson gives the Landlord one hundred eighty (180) days advance notice of termination; and

WHEREAS, the minimum annual rent is set at \$19.55 per square foot, which is \$9,151.03 per month for the first period of 60 months for 5,617 square feet of rentable space, and if the Lease agreement is renewed for an additional 60 months, the minimum annual rent is set at \$21.05 per square foot, which is \$9,853.15 per month, which includes operating construction, and common area maintenance costs; and

WHEREAS, the leased premises will be used solely for an office for the Jackson Police Department, Precinct No. 2; therefore, the Landlord will perform the work in Exhibit A for the benefit of the City of Jackson at a cost not to exceed \$530,000.00; and

WHEREAS, the cost of construction is included in the rental payment over the period of the Lease, however should the City of Jackson terminate the Lease prior to the expiration of a ten (10) year term, then the City shall repay the Landlord at a zero percent (0%) amortized rate; and

WHEREAS, while this work is being performed, the Landlord will provide a temporary space for Precinct No. 2 to conduct its operations at no additional charge to the City of Jackson, which is also located in the Westland Plaza Shopping Center; and

WHEREAS, the City will be responsible for paying all utilities, including water rates, and charges, all sewer rates and all charges for electricity, gas, steam, hot and/or chilled water, air conditioning, ventilating, lighting systems, and any other utility supplied to the premises; and

WHEREAS, it is expressly understood and agreed that the obligation of the City of Jackson to proceed under this Lease is conditioned upon the appropriation of funds by the City Council and the receipt of funds. If the funds anticipated for the continuing fulfillment of the Lease are, at any time, not forthcoming or insufficient, either through the failure of the City of Jackson to provide funds or of the City Council to appropriate funds or the discontinuance or material alteration of the program under which funds were provided or if funds are not otherwise available to the City of Jackson, the City shall have the right upon ten (10) working days written notice to the Landlord to terminate this Lease without damage, penalty, cost or expenses to the City of any kind whatsoever, other than payment for services rendered prior to receiving written notice. The effective date of termination shall be as specified in the notice of termination; and

WHEREAS, it is understood that this Lease requires approval by the governing authorities for the City of Jackson and, if it is not approved, then it is void and no payment shall be made; and

WHEREAS, in the event that Landlord or the City of Jackson is delayed or hindered in or prevented from doing or performing any act or thing required hereunder by reason of strike, lock-outs, casualties, Acts of God, labor troubles, terrorism, inability to procure materials, failure of power, governmental laws or regulations, riots, insurrection, war or other causes beyond the reasonable control of Landlord or City of Jackson, then neither Landlord nor City of Jackson shall be liable or responsible for any such delays and the doing or performing of such act or thing shall be excused for the period of the delay and the period for the performance of any such act shall be extended for a period equivalent to the period of such delay.

IT IS, THEREFORE, ORDERED that the Mayor is authorized to execute a Lease and related documents with Westland Shopping Center, L.P., represented by its General Partner, Westland SC GP, Inc., to relocate the Jackson Police Department Precinct No. 2 to the Westland Plaza Shopping Center from the Metrocenter Mall.

IT IS FURTHER ORDERED that the Jackson Police Department shall make rental payments as outlined in this order and the Lease agreement.

Council Member Grizzell moved adoption; **Vice President Lee** seconded.

President Foote recognized **Allen Carr, Property Manager** and **Chloe Dotson, Director of Planning and Development**, who provided a brief overview of said item.

Thereafter, **President Foote**, called for a vote of said item:

- Yeas – Banks, Foote, Grizzell, Hartley, Lee and Lindsay.
- Nays – None.
- Absent – Stokes.

* * * * *

ORDER AUTHORIZING THE MAYOR TO EXECUTE A LEASE AND RELATED DOCUMENTS WITH JACKSON-NORTH STATE, LLC TO LEASE OFFICE SPACE FOR THE COJ EMPLOYEE CLINIC, THE DEPARTMENT OF HUMAN AND CULTURAL SERVICES, THE DEPARTMENT OF HUMAN RESOURCES AND THE DEPARTMENT OF PARKS AND RECREATION.

WHEREAS, currently, the COJ Employee Clinic, the Department of Human and Cultural Services, the Department of Human Resources, and the Department of Parks and Recreation are housed in the Metrocenter Mall; however, the Metrocenter Mall is in such a consistent state of disrepair that these departments must be relocated to an alternate location; and

WHEREAS, the Department of Planning and Development recommends that the City of Jackson enter into a Lease agreement for office space with Jackson-North State, LLC (hereinafter “Landlord”), with its principal office at 633 North State Street, Jackson, Mississippi 39202; and

WHEREAS, the Landlord proposes a 60-month agreement which, unless the City of Jackson has notified the Landlord of termination of the Lease on or before one hundred eighty (180) days of the initial period, will automatically renew for a period of sixty (60) months; and

WHEREAS, the base rent for the first 60 months is \$36,229.17 a month and if this Lease is automatically renewed, the base rent will be \$39,852.08 a month for the second five (5) year term; and

WHEREAS, the base rent amounts are estimated based upon the Rentable Area of Premises which is approximately 34,780 rentable square feet and are subject to confirmation of such measurement (\$12.50 per RSF for months 1-60 and \$13.75 per RSF for months 61-120); and

WHEREAS, the auto-renewal term will automatically commence in month sixty-one (61), under the same terms and conditions, with the exception of Base Rent, as the Initial Term, unless the City of Jackson gives Landlord one hundred eighty (180) days advance notice of termination; and

WHEREAS, the City of Jackson will have two (2) options to extend the term of the Lease for an additional five (5) years; and

WHEREAS, the premises will only be used for professional offices for the City of Jackson, including the in-house clinic facilities, and the premises may not be used for any other purpose, including, without limitation, retail or residential use, without the prior express written consent of Landlord, which may be withheld in Landlord's sole discretion; and

WHEREAS, the Landlord will also make improvements to the facility to house the various department as well as the employee health clinic; and

WHEREAS, the Landlord will (i) install new flooring on each floor of the Premises, (ii) build out space for clinic facilities, (iii) paint the walls of each floor of the Premises, (iv) install partial lighting upgrades in the premises and the building, (v) install replacement plumbing fixtures, and (vi) any additional improvements to the premises which are requested by City of Jackson and approved by Landlord; and

WHEREAS, the Landlord shall pay \$350,000.00 for the construction of the Initial Building/Premises Improvements (Landlord Improvement Allowance), however the City will be responsible for any cost of construction which are in excess of the Landlord Improvement Allowance, which will be charged as additional rents to be paid out over the life of the Lease; and

WHEREAS, notwithstanding the \$350,000.00, the City understands and agrees that the Landlord will expend funds in an amount not to exceed \$100,000.00, unless agreed to by Landlord in writing, to build out space for clinic facilities that will be Tenant specific improvements to be reimbursed (actual amount of expenditure, not estimate) by the City as additional payments spread out over the course of the Initial Term; and

WHEREAS, if the City of Jackson should terminate this Lease prior to the expiration of the initial 60-month term that Landlord will suffer damage in the amount still owing to Landlord for the COJ employee clinic, the City of Jackson, shall owe to Landlord the amount remaining to be paid for the clinic facilities with said amount due and payable to Landlord forty-five (45) days from the notice of termination given to Landlord; and

WHEREAS, the parties agree that this is not a termination fee, but is based solely on the amount Tenant will owe to Landlord for the tenant specific improvement build-out for the City's on-site clinic facilities; and

WHEREAS, if applicable, all interest, late charges, fees, charges, and other amounts payable under this Lease will constitute additional rent; and

WHEREAS, the Landlord will also deliver a statement providing the amount of the City of Jackson's pro-rata share of operating expenses for each calendar year of the term by February 28th of the following year, and the City of Jackson shall pay such amount to Landlord on or before April 30th of the next year; and

WHEREAS, the operating expenses shall not exceed an amount of \$20,000.00 on an annual basis without additional City Council approval; and

WHEREAS, if Landlord fails to perform any of its obligations hereunder, Landlord shall not be in default and the City of Jackson shall not have any rights or remedies growing out of such failure unless the City of Jackson gives Landlord written notice setting forth in reasonable detail the nature and extent of such failure and such failure is not cured within thirty (30) days following Landlord's receipt of such notice or such longer period as may otherwise be provided herein; and

WHEREAS, if such failure cannot reasonably be cured within thirty (30) days, the length for curing shall be extended as reasonably required. In the event Landlord shall be in default (as stated above) and thereafter fails to provide such services within a reasonable time, the City of Jackson shall have the right, but not the obligation, to perform such obligations; and upon receipt of a demand therefor, Landlord shall reimburse the City for the actual and reasonable cost of performing such obligations, plus interest thereon; and

WHEREAS, each party shall be excused for the period of any delay and shall not be deemed in default with respect to the performance of any of its obligations when prevented from so doing by a cause beyond such party's reasonable control, including labor disputes, government regulations, fire or casualty, acts of terrorism, inability to obtain any materials or services, or acts of God; and

WHEREAS, it is understood that this Lease requires approval by the governing authorities for the City of Jackson and, if it is not approved, then it is void and no payment shall be made; and

WHEREAS, it is expressly understood and agreed that the obligation of the City of Jackson to proceed under this Lease is conditioned upon the appropriation of funds by the City Council and the receipt of funds and if the funds anticipated for the continuing fulfillment of the Lease are, at any time, not forthcoming or insufficient, either through the failure of the City of Jackson to provide funds or of the City Council to appropriate funds or the discontinuance or material alteration of the program under which funds were provided or if funds are not otherwise available to the City of Jackson, the City shall have the right upon ten (10) working days written notice to the Landlord to terminate this Lease without damage, penalty, cost or expenses to the City of any kind whatsoever, other rental payments accrued prior to receiving written notice and vacating the premises.

IT IS, THEREFORE, ORDERED that the Mayor is authorized to execute a Lease and related documents with Jackson-North State, LLC to relocate the COJ Employee Clinic, the Department of Human And Cultural Services, the Department of Human Resources, and the Department of Parks And Recreation to 633 North State Street, Jackson, Mississippi 39202 due to the Metrocenter Mall being in such a consistent state of disrepair.

IT IS FURTHER ORDERED that the respective departments are to make payment as outlined in this Order and the Lease agreement.

Council Member Lindsay moved adoption; **Council Member Grizzell** seconded.

Yeas – Banks, Foote, Grizzell, Hartley, Lee and Lindsay.

Nays – None.

Absent – Stokes.

* * * * *

ORDER AUTHORIZING THE MAYOR TO EXECUTE AN AGREEMENT BETWEEN THE CITY OF JACKSON, MISSISSIPPI, AND BIG MOKEY TRAIN, INC., FOR THE USE OF A TWENTY-FOUR-INCH (24") GAUGE TRAIN AT THE JACKSON ZOO LOCATED AT 2918 WEST CAPITOL STREET, JACKSON, MISSISSIPPI.

WHEREAS, Section 21-17-5(1) of the Mississippi Code, as Amended, states that the governing authorities of every municipality of the state shall have the care, management, and control of its municipal affairs, property, and finances; and

WHEREAS, the Jackson Zoo and the Department of Parks and Recreation wish to enter into an Agreement with Big Mokey Trains, Inc., ("Big Mokey Train") for the rental and use of a twenty-four-inch (24") gauge train; and

WHEREAS, Big Mokey Train has provided an Agreement for the rental and use of a twenty-four-inch (24") gauge train with one (1) locomotive and three (3) coaches, to be used by the Jackson Zoo for a period of twelve (12) months; and

WHEREAS, the Jackson Zoo shall pay Big Mokey Train fifty percent (50%) of all monthly train ticket sales (ticket prices shall be \$3.00 per person, per ride) accompanied by a detailed written report of daily train ticket sales; and

WHEREAS, the Jackson Zoo shall include information about the operational train in all advertisements of attractions available at the Jackson Zoo; and

WHEREAS, the Jackson Zoo shall provide all fuel and oil for the train to be operational at the Jackson Zoo; and

WHEREAS, the Jackson Zoo shall provide staff and designate a supervisor to oversee proper protocol, checklists completion, operations, and maintenance of the train engine, coaches, and train track; and

WHEREAS, Big Mokey Train shall provide the Jackson Zoo with tickets to be used for train rides; and

WHEREAS, Big Mokey Train shall remain responsible for all major repairs and maintenance on the engine and coaches, including but not limited to, brakes, rear-end work, and transmission; and

WHEREAS, In the event of train inoperability/break-down, Big Mokey Train shall replace any inoperable unit(s) with serviceable unit(s) within forty-eight (48) hours after being notified of train inoperability; and

WHEREAS, the Jackson Zoo shall use its own maintenance staff for minor train repairs and routine train maintenance; and

WHEREAS, neither the City of Jackson nor the Jackson Zoo shall be liable for any injuries or damages to any persons or property occurring from the use and operation of said train, unless caused by the gross negligence of the City of Jackson and/or the Jackson Zoo; and

WHEREAS, Big Mokey Train shall maintain a liability insurance policy with a minimum of One Million (\$1,000,000.00) Dollars in personal injury coverage and a minimum of One Million (\$1,000,000.00) Dollars in property damage coverage, listing the City of Jackson as an additional named insured in said policy; and

WHEREAS, Big Mokey Train shall provide a copy of said liability insurance policy and a Certificate of Coverage to the City of Jackson and the Jackson Zoo, before the train begins operation; and

WHEREAS, Big Mokey Train shall maintain an operational train as agreed upon in the Agreement at the Jackson Zoo for a period of twelve (12) months, said twelve (12) months commencing upon the first day the train is operational for public use; and

WHEREAS, the Agreement may be terminated with cause by either party upon providing a sixty (60) day written notice to the other party; and

WHEREAS, In the event of an early termination as outlined above, Big Mokey Train shall be given a reasonable amount of time to remove the train.

IT IS, THEREFORE, ORDERED that the Mayor be authorized to execute an Agreement with Big Mokey Train for the use of a twenty-four-inch (24") gauge train with one (1) locomotive and three (3) coaches, to be used by the Jackson Zoo for a period of twelve (12) months commencing upon the first day that the train is operational for public use, with the Jackson Zoo paying Big Mokey Train fifty percent (50%) of all train ride ticket sales.

IT IS FUTHERED ORDERED that payment for this Agreement be made from the funds budgeted for use by the Jackson Zoo, upon submission of the appropriate invoices from Big Mokey Train.

Vice President Lee moved adoption; **Council Member Hartley** seconded.

Yeas – Banks, Foote, Grizzell, Hartley, Lee and Lindsay.
Nays – None.
Absent – Stokes.

* * * * *

ORDER RATIFYING PAYMENTS FOR SERVICES PERFORMED BY OVG 360 MANAGEMENT GROUP AND IATSE LOCAL 589, IN THE AMOUNT OF TWO THOUSAND SIX HUNDRED TWENTY-ONE DOLLARS AND FORTY CENTS (\$2,621.40).

WHEREAS, the OVG 360 Management Group (“OVG 360”) of the Jackson Convention Center and IATSE Local 589 (“IATSE”) with Thalia Maria Hall, both performed services for the City of Jackson, Parks and Recreation Department, on three (3) separate dates; and

WHEREAS, OVG 360 for the Jackson Convention Center provided the following services totaling One Thousand Dollars (\$1,000.00) for the Jackson African American Male Wellness Walk on April 22, 2023: Ballroom D at the discounted rate of Five Hundred Dollars (\$500.00); six (6) hours of security services for two hundred plus (200+) participants at the rate of Twenty-Five Dollars (\$25.00) per hour; and janitorial services at the rate of Three Hundred and Fifty Dollars (\$350.00); and

WHEREAS, IATSE with Thalia Maria Hall provided the following services totaling One Thousand Sixteen Dollars and Forty Cents (\$1,016.40) for the Five Heartbeat Musical on February 4, 2023: stage set-up, focus lighting, and gel lighting at the rate of Twenty Dollars (\$20.00) per hour with a twenty-one percent (21%) payroll fee for six (6) employees during the seven (7) hours of set-up time; and

WHEREAS, IATSE with Thalia Maria Hall also provided the following services totaling Six Hundred and Five Dollars (\$605.00) for the Mic Check with a Twist event on March 17, 2023: stage set-up, focus lighting, and gel lighting at the rate of Twenty Dollars (\$20.00) per hour with a twenty-one percent (21%) payroll fee for five (5) employees during the six (6) hours of set-up time.

IT IS HEREBY ORDERED that a payment in the amount of One Thousand Dollars (\$1,000.00) be made to OVG 360 from account number 005.501.10-6512 for providing the above listed services, on April 22, 2023, for the Department of Parks and Recreation.

IT IS FURTHER ORDERED that a payment in the amount of One Thousand Six Hundred Twenty-One Dollars and Forty Cents (\$1,621.40) be made to IATSE from account no. 005.501.25-6419 for providing the above listed services, on February 4, 2023, and March 17, 2023, for the Department of Parks and Recreation.

Council Member Grizzell moved adoption; **Vice President Lee** seconded.

President Foote recognized **Ison Harris, Director of Parks and Recreation**, who provided a brief overview of said item.

Thereafter, **President Foote**, called for a vote of said item:

Yeas – Banks, Foote, Grizzell, Hartley, Lee and Lindsay.

Nays – None.

Absent – Stokes.

* * * * *

ORDER ACCEPTING THE SPONSORSHIP OF A FIREWORKS DISPLAY FROM DOWNTOWN PARTNERS, LLC, FOR THE SPECIFIC PURPOSE OF PROVIDING A FIREWORKS EXHIBITION NEAR 105 EAST PASCAGOULA STREET ON FRIDAY, JUNE 16, 2023, FOR THE OBSERVANCE OF JUNETEENTH.

WHEREAS, Section 21-17-5(1) of the Mississippi Code, as Amended, states that the governing authorities of every municipality of the state shall have the care, management, and control of its municipal affairs, property, and finances; and

WHEREAS, Mississippi Attorney General Opinion Number 2010-00022 (2010 WL 942877) states that municipal governing authorities have the authority to accept donations for **specifically** designated purposes; and

WHEREAS, Downtown Partners, LLC, (“Downtown Partners”) has indicated that it is sponsoring the fireworks display for the City of Jackson’s Juneteenth Fireworks Extravaganza with no expectation of future favorable treatment by the City of Jackson and with no intention of influencing or attempting to influence any future City of Jackson municipal action(s); and

WHEREAS, Downtown Partners is a Mississippi limited liability company in good standing according to the information appearing in the online database of the Mississippi Secretary of State’s website; and

WHEREAS, Downtown Partners’ sponsorship of the fireworks display arises from its desire to support the City of Jackson and the Department of Parks and Recreation in their efforts to observe Juneteenth; and

WHEREAS, the Department of Parks and Recreation desires permission to accept Downtown Partners’ sponsorship of the fireworks display; and

WHEREAS, the Department of Parks and Recreation is requesting permission to have the Juneteenth Street Festival and Firework Exhibition near 105 East Pascagoula Street, Jackson, Mississippi, on Friday, June 16, 2023.

IT IS, THEREFORE, ORDERED that the Mayor be authorized to execute any and all documents accepting the sponsorship of the fireworks display by Downtown Partners.

IT IS FURTHER ORDERED that said fireworks display shall be used on Friday, June 16, 2023, in the City of Jackson’s observance of Juneteenth.

Council Member Grizzell moved adoption; **Vice President Lee** seconded.

President Foote recognized **Ison Harris, Director of Parks and Recreation**, who provided a brief overview of said item.

Thereafter, **President Foote**, called for a vote of said item:

Yeas – Banks, Foote, Grizzell, Hartley, Lee and Lindsay.

Nays – None.

Absent – Stokes.

ORDER PROPOSING REVISED FEE SCHEDULES FOR THE FOLLOWING CITY OF JACKSON, MISSISSIPPI, RECREATIONAL FACILITIES: PETE BROWN GOLF FACILITY, GROVE PARK GOLF COURSE, AND THE JACKSON ZOO.

WHEREAS, the City of Jackson, Department of Parks and Recreation, provides full golf services at the Pete Brown Golf Facility and the Grove Park Golf Course, as well as educational and zoological experiences at the Jackson Zoo, to the general public at certain set prices; and

WHEREAS, the current fees at the Pete Brown Golf Facility have been in place since December 20, 2019; and

WHEREAS, the fee schedule adjustments at each above facility are to provide fair and comparable fees and to attract more public participation; and

WHEREAS, the City of Jackson Parks and Recreation Department proposes revising the fee schedules, as listed below:

PETE BROWN GOLF FACILITY

	OLD FEES	NEW FEES
GREEN FEES	9-HOLE WEEKDAY \$10.50	9-HOLE WEEKDAY \$12.00
	18-HOLE WEEKDAY \$12.50	18-HOLE WEEKDAY \$14.00
	9-HOLE WEEKEND \$14.50	9-HOLE WEEKEND \$14.00
	18-HOLE WEEKEND \$14.40	18-HOLE WEEKEND \$16.00
CART FEES	9-HOLE \$6.25	9-HOLE \$8.00
	18-HOLE \$12.50	18-HOLE \$16.00
DRIVING RANGE FEES	SMALL BUCKET \$3.50	SMALL BUCKET \$5.00
	MEDIUM BUCKET \$5.00	MEDIUM BUCKET \$7.00

**REGULAR MEETING OF THE CITY COUNCIL
TUESDAY, MAY 9, 2023 10:00 A.M.**

	LARGE BUCKET \$8.50	LARGE BUCKET \$9.00
	JUMBO BUCKET \$12.50	JUMBO BUCKET \$10.00
MEMBERSHIP MONTHLY FEES	SENIOR RATE \$35.00	SENIOR RATE \$40.00
	REGULAR \$50.00	REGULAR RATE \$60.00
MEMBERSHIP ANNUAL FEES		SENIOR RATE \$650.00
		REGULAR RATE \$800.00
MEMBERSHIP ANNUAL GOLF PASSES (JAN-FEB)	SENIOR RATE \$670.00	SENIOR RATE \$600.00
	REGULAR RATE \$900.00	REGULAR RATE \$750.00
MEMBERSHIP ANNUAL SINGLE GOLF FEES	SENIOR RATE \$720.00	SENIOR RATE \$800.00
	REGULAR RATE \$950.00	REGULAR RATE \$950.00

GROVE PARK GOLF COURSE

	OLD FEES	NEW FEES
GREEN FEES		9-HOLE WEEKDAY \$8.00
		18-HOLE WEEKDAY \$10.00
		9-HOLE WEEKEND \$10.00
		18-HOLE WEEKEND \$10.00
CART FEES		9-HOLE \$7.00
		18-HOLE \$14.00
MEMBERSHIP MONTHLY FEES		SENIOR RATE \$25.00
		REGULAR RATE \$35.00
· Yearly fee does not include Golf Cart Fee (ONLY Green Fee)		

THE JACKSON ZOO

MEMBERSHIP	FAMILY (4)	\$150.00
	EACH ADDITIONAL CHILD	\$10.00
SINGLE-MEMBER		\$100.00
MILITARY		10% DISCOUNT
SENIOR		10% DISCOUNT
ZOO DAY ICE CREAM SAFARI	MEMBERSHIP COVERS ADMISSION, BUT NOT SPECIAL TICKETS	
	CAROUSEL RIDE INCLUDED WITH MEMBERSHIP	

IT IS HEREBY ORDERED that the proposed fee schedule revisions for the City of Jackson, Department of Parks and Recreation, Pete Brown Golf Facility, Grove Park Golf Course, and the Jackson Zoo, be hereby ratified and adopted as provided in the above-referenced charts.

Council Member Grizzell moved adoption; **Council Member Lindsay** seconded.

President Foote recognized **Ison Harris, Director of Parks and Recreation**, who provided a brief overview of said item.

Thereafter, **President Foote**, called for a vote of said item:

Yeas – Banks, Foote, Grizzell, Hartley, Lee and Lindsay.
Nays – None.
Absent – Stokes.

ORDER AMENDING THE FISCAL YEAR 2022-2023 BUDGET FOR THE DEPARTMENT OF PARKS AND RECREATION TO TRANSFER \$66,974.42 FROM THE PERSONAL SERVICES CATEGORY TO THE FOLLOWING: FEED FOR ANIMALS CATEGORY, OTHER PROFESSIONAL SERVICES CATEGORY, BUILDING MAINTENANCE CATEGORY, AND THE SUNDRY CATEGORY, IN ORDER TO ASSIST

**WITH FEEDING ANIMALS, BUILDING MAINTENANCE, AND EMPLOYEE WAGES
AT THE JACKSON ZOO.**

WHEREAS, Section 21-17-5(1) of the Mississippi Code Annotated, as amended, states that the governing authorities of every municipality of the state shall have the care, management, and control of its municipal affairs, property, and finances; and

WHEREAS, it is the sincere desire of the City of Jackson, Department of Parks and Recreation, to provide consistent and outstanding service to our citizens and visiting guests at the Jackson Zoo. To help accomplish this endeavor, adequate animal feedings, building maintenance, and staff wages are critically needed. Especially with the ongoing occurrence of major structural breakdowns, the rising cost of animal feed, and staffing shortages faced by the Jackson Zoo, all of which have caused and contributed to revenue losses; and

WHEREAS, Section 21-35-25 of the Mississippi Code Annotated, as amended, states that if it affirmatively appears at any time during the current fiscal year that there is in any fund or account any sum remaining unexpended and not needed or expected to be needed for the purpose or purposes for which appropriated in said budget, then the governing authorities may, in their discretion, transfer such sum or any part thereof to any other fund or funds or account or accounts where needed, by order to such effect entered upon their minutes. This shall not, however, authorize the expenditure of any funds for any purpose other than that for which the levy producing such funds was made; and

WHEREAS, the Department of Parks and Recreation represents that the Sixty-Six Thousand Nine-Hundred Seventy-Four Dollars and Forty-Two Cents (\$66,974.42) currently located in the “Personal Services” category, that it presently seeks to transfer to other categories, is not needed or expected to be needed for the purpose(s) for which it was originally appropriated in the Fiscal Year 2022-2023 Budget; and

WHEREAS, the Sixty-Six Thousand Nine-Hundred Seventy-Four Dollars and Forty-Two Cents (\$66,974.42) located in the “Personal Services” category is comprised of unspent funds for vacant positions; and

WHEREAS, the Department of Parks and Recreation needs this requested Budget amendment so that the Jackson Zoo may continue purchasing food for the animals, continue efforts to fix the severe structural maintenance issues, and help with the cost of wages and overtime, especially as summer is approaching and with it an increased number of guests visiting the Jackson Zoo; and

WHEREAS, the following funds are requested to be transferred to the following categories listed below:

FUNDS TRANSFER FROM:		FUNDS TRANSFER TO:	
Personal Services Category Account: 390-498.00-6111	\$66,974.42	Feed For Animals Category Account: 390-498.00-6214	\$20,000.00
		Other Professional Services Category Account: 390-498.00 - 6419	\$20,000.00
		Building Maintenance Category Account: 390-498.00 - 6461	\$20,000.00
		Sundry Category Account: 390-498.00 - 6730	\$6,974.42
		Total Funds Transfer Request	\$66,974.42

WHEREAS, this intradepartmental transfer of Sixty-Six Thousand Nine-Hundred Seventy-Four Dollars and Forty-Two Cents (\$66,974.42) is in statutory compliance with Section 21-35-25 of the Mississippi Code Annotated, as amended, because the transfer requested in this Order, added to any previous Fiscal Year 2022-2023 Department of Parks and Recreation Budget intradepartmental transfers, does not exceed ten percent (10%) of the total budget amount appropriated to the Fiscal Year 2022-2023 Department of Parks and Recreation Budget.

IT IS, THEREFORE, ORDERED that the Fiscal Year 2022-2023 Budget for the Department of Parks and Recreation be amended to authorize a Budget transfer of Sixty-Six Thousand Nine-Hundred Seventy-Four Dollars and Forty-Two Cents (\$66,974.42) from the “Personal Services” category, to be allocated as follows:

FUNDS TRANSFER FROM:		FUNDS TRANSFER TO:	
Personal Services Category Account: 390-498.00-6111	\$66,974.42	Feed For Animals Category Account: 390-498.00-6214	\$20,000.00
		Other Professional Services Category Account: 390-498.00 - 6419	\$20,000.00
		Building Maintenance Category Account: 390-498.00 - 6461	\$20,000.00
		Sundry Category Account: 390-498.00 - 6730	\$6,974.42
		Total Funds Transfer Request	\$66,974.42

Vice President Lee moved adoption; **Council Member Grizzell** seconded.

Yeas – Banks, Foote, Grizzell, Hartley, Lee and Lindsay.

Nays – None.

Absent – Stokes.

* * * * *

ORDER AMENDING THE APRIL 11, 2023 ORDER ACCEPTNG THE BIDS OF MANDEL METALS, INC., d/b/a US STANDARD SIGN FOR 18 MONTH SUPPLY OF ALUMINUM SIGN BLANKS, (BID NO. 55063-010323) TO INCLUDE AND ACCEPT THE BID OF NEWMAN SIGNS, INC.

WHEREAS, the Department of Public Works issued an advertisement for bids for the eighteen-month supply of aluminum sign blank: and

WHEREAS, the advertisement requested a bid for flat aluminum traffic control sign blanks, extruded aluminum street mime sign blanks, and flat aluminum street name sign blanks in carious sins: and

WHEREAS, on April 11, 2023, the governing authorities for the City of Jackson accepted the Bid of Mandel Metals, Inc. d/b/a US Standard Sign for eighteen-month supplies of aluminum sign blanks; and

WHEREAS, the Department of Public Works recommends that the governing authorities of the City of Jackson amend its April 11, 2023 order also to accept the bid of Newman Signs, Inc.; and

WHEREAS, the Department of Public Works recommends that the governing authority accepts the lowest and best bid of Newman Signs, Inc. for the following items for the supply of aluminum sign blanks:

Section 1: 4, 12, 15, 17, 24, 26, 27, 28, 32, 33, 34, 36, 38, 39, 44, 45, 46, 47, 54, 55, 56, 57, 58; and

Section 3: 1-11

WHEREAS, the Department of Public Works recommends that the governing authority accepts the lowest and best bid of Mandel Metals, Inc. d/b/a US Standard Sign for the following items for the supply of aluminum sign blanks:

Section 1: 1, 2, 3, 5, 6, 7, 8, 9, 10, 11, 13, 14, 16, 18, 19, 20, 21, 22, 23, 25, 29, 30, 31, 35, 37, 40, 41, 42, 43, 48, 49, 50, 51, 52, 53, 59, 60, 61 and Section 2: 1-6.

IT IS, THEREFORE, ORDERED that the bids, 55063-010323 be amended as enumerated below for an eighteen-month (February 1, 2023 through August 31, 2024) term for the supply of aluminum sign blanks, be accepted as the lowest and best bids received:

**REGULAR MEETING OF THE CITY COUNCIL
TUESDAY, MAY 9, 2023 10:00 A.M.**

COMPANY NAME

ITEMS

Mandel Metals. Inc.	Section 1: 1, 2,35,6,7,8,9,10.11,13,14,16,18,19,20,21,22,23,25,29,30,31., 35, 37, 40, 41, 42, 43, 48, 49, 50, 51, 52, 53, 59, 60, 61 and Section 2: 1-6
Newman Signs, Inc.	Section 1:4, 12,15,17,24,26,27,28,32,33,34,36,38,39,44,45,46,47,54,55,56,57,58; and Sections 3: 1-11

IT IS FURTHER ORDERED that the Mayor is authorized to execute any and all documents necessary for the Public Works Department to make payments for said Aluminum Sign Blanks from the General Fund.

Vice President Lee moved adoption; **Council Member Lindsay** seconded.

President Foote recognized **Robert Lee, Interim Director of Public Works**, who provided a brief overview of said item.

Thereafter, **President Foote**, called for a vote of said item:

Yeas – Banks, Foote, Grizzell, Hartley, Lee and Lindsay.

Nays – None.

Absent – Stokes.

* * * * *

ORDER AUTHORIZING THE MAYOR TO EXECUTE AN AMENDMENT TO THE PROFESSIONAL SERVICES AGREEMENT WITH BENCHMARK CONSTRUCTION CORPORATION FOR EMERGENCY PROJECT MANAGEMENT.

WHEREAS, the City of Jackson Department of Public Works and Department of Human and Cultural Services are currently in the process of preparing Thalia Mara Hall and the Arts Center of Mississippi for the USA International Ballet Competition ("USA IBC"); and

WHEREAS, the USA IBC is a two-week "Olympic-style" competition for top young dancers from all over the world which occurs every four (4) years in the City of Jackson and is scheduled to take place June 10, 2023 through June 24, 2023; and

WHEREAS, the 2018 USA IBC was attended by more than 44,000 people generating a combined economic impact of \$12.5 million for the City of Jackson and the State of Mississippi; and

WHEREAS, necessary repairs which must take place at both Thalia Mara and the Arts Center prior to June 10, 2023 are currently underway under the management of Benchmark Construction Corporation; and

WHEREAS, the scope of the work originally negotiated did not originally include the Arts Center of Mississippi, which was added to Benchmark's scope just prior to the presentation of the original order to the City Council at its February 28, 2023 meeting; and

WHEREAS, due to cost savings with some of the work originally contemplated in the scope of work for Thalia Mara Hall, additional projects to further enhance the appearance and environment of Thalia Mara Hall have been identified and are currently progressing toward completion; and

WHEREAS, the additions to the scope of work have resulted in Benchmark Construction Corporation expending additional time in the management of both Thalia Mara Hall and the Arts Center of Mississippi; and

WHEREAS, Benchmark Construction Corporation has estimated that management of the additional scopes of work will require additional management and supervisory services in an amount up

to \$52,550.00, which will increase the not to exceed amount of the agreement from \$75,000.00 to \$127,550.00; and

WHEREAS, the Department of Public Works recommends approving the amendment to accomplish the additional scopes of work prior to the U.S.A. International Ballet Competition.

IT IS, THEREFORE, ORDERED that the Mayor is authorized to execute an amendment to the professional services agreement with Benchmark Construction Corporation to provide project management services to the City of Jackson to increase the not to exceed amount of the agreement to \$127,550.00.

Vice President Lee moved adoption; **Council Member Grizzell** seconded.

Yeas – Banks, Foote, Grizzell, Hartley, Lee and Lindsay.
Nays – None.
Absent – Stokes.

There came on for consideration Agenda Item No. 30:

RESOLUTION OF THE CITY COUNCIL OF JACKSON, MISSISSIPPI HONORING, RECOGNIZING AND SUPPORTING THE ANNUAL JUNETEENTH FREEDOM AND UNITY CULTURAL CELEBRATION. **President Foote** stated said item would be pulled due to the absence of **Council Member Stokes**.

RESOLUTION OF THE CITY COUNCIL OF JACKSON, MISSISSIPPI RECOGNIZING, SUPPORTING THE CELEBRATION OF MOTHER’S DAY, 2023.

WHEREAS, the celebration of Mother’s Day was started in the early 20th century by an American, Anna Jarvis, who never became a mother; at the age of twelve, Anna heard her mother as she prayed that someone would begin a day of commemoration to recognize the role mothers play in the development of humankind; and

WHEREAS, in 1907, two years after Ann Marie Jarvis died, her daughter, Anna, began an aggressive campaign to establish Mother’s Day; in 1914, Mother’s Day became an official holiday in the US.; and

WHEREAS, in almost every culture throughout the world, mothers are deeply respected and revered as the foundation of the most basic unit- - the family; and

WHEREAS, traditions of recognition for mother, step-mothers, mothers-in-law, grandmother, great- grandmothers, mother figures and female relatives are diverse; and

WHEREAS, because of the affirmation of the important role of mothers in nurturing children and building a stronger society, the entire nation and world join the City of Jackson in recognizing and supporting the observance of Mother’s Day, 2023.

THEREFORE, IT IS HEREBY RESOLVED that the City Council of Jackson, Mississippi hereby recognizes and supports the observance of Mother’s Day, 2018.

Council Member Grizzell moved adoption; **Vice President Lee** seconded.

Yeas – Banks, Foote, Grizzell, Hartley, Lee and Lindsay.
Nays – None.
Absent – Stokes.

There came on for consideration Agenda Item No. 30:

RESOLUTION OF THE CITY COUNCIL OF JACKSON MISSISSIPPI VOTE OF NO CONFIDENCE IN THE INTERIM DIRECTOR OF PUBLIC WORKS. President Foote stated said item would be pulled due to the absence of Council Member Stokes.

* * * * *

President Foote recognized **Vice President Lee** who moved, seconded by **Council Member Grizzell** to reconsider Claims. The motion prevailed by the following vote:

Yeas – Foote, Grizzell, Lee and Lindsay.
Nays – Banks and Hartley.
Absent – Stokes.

Thereafter, **President Foote** requested that the Clerk read the order as amended:

ORDER APPROVING CLAIMS NUMBER 28781 to 28847 APPEARING AT PAGES 421 TO 451 INCLUSIVE THEREON, ON MUNICIPAL “DOCKET OF CLAIMS”, IN THE AMOUNT OF \$7,058,172.50 AND MAKING APPROPRIATIONS FOR THE PAYMENT THEREOF.

IT IS HEREBY ORDERED that claims numbered 28781 to 28847 appearing at pages 421 to 451, inclusive thereon in the Municipal “Docket of Claims”, in the aggregate amount of \$7,058,172.50 are hereby approved for payment and said amount is expressly appropriated for the immediate payment thereof.

IT IS FURTHER ORDERED that there is appropriated from the various funds the sums necessary to be transferred to other funds for the purpose of paying the claims as follows:

FROM:	TO ACCOUNTS PAYABLE FUND
GENERAL FUND	2,015,841.78
SEIZURE & FORF PORP-FED	49,666.67
TECHNOLOGY FUND	31,005.48
PARKS & RECR. FUND	54,382.73
BUSINESS IMPROV FUND (LANDSCP)	58,645.87
LANDFILL/SANITATION FUND	809,534.29
STATE TORT CLAIMS FUND	102,899.38
WATER/SEWER REVENUE FUND	889.29
WATER/SEWER OP & MAINT FUND	1,284,163.06
WATER/SEWER CAPITAL IMPR FUND	36,474.82
DISABILITY RELIEF FUND	107,882.66
EMPLOYEES GROUP INSURANCE FUND	143,287.80
KELLOGG FOUNDATION PROJECT	40,833.33
HOUSING COM DEV ACT (CDBG) FD	20,486.55
UNEMPLOYMENT COMPENSATION REVO	36,302.23
HOME PROGRAM FUND	47.95
H O P W A GRANT – DEPT. OF HUD	104,340.28
INFRASTRUCTURE BOND 2020 \$32M	142,459.66
1% INFRASTRUCTURE TAX	10,982.48
TRANSPORTATION FUND	750,012.21
FONDREN BUSINESS IMPROV FUND	3,962.12
MHC BLIGHT ELIMINATION PROGRAM	27,750.06
SIEMENS SETTLEMENT ACCOUNT	454,045.94

**REGULAR MEETING OF THE CITY COUNCIL
TUESDAY, MAY 9, 2023 10:00 A.M.**

183

ESG COVID CARES ACT	23,711.67
CDBG COVID CARES	39,418.62
ZOOLOGICAL PARK	38,133.02
LIBRARY FUND	171,704.16
DFA – SB2971 – LIVINGSTON PARK	15,000.00
DFA – SB2971 – PETE BROWN GOLF	63,331.00
DFA – THALIA MARA HALL \$2M	352,134.68
2022 GO PLANETARIUM BOND \$7.5M	32,250.00
BELHAVEN COMMUNITY IMPROVEMENT	4,026.62
TOTAL	<u>\$7,058,172.50</u>

President Foote moved adoption; **Council Member Hartley** seconded.

President Foote recognized **Vice President Lee** who moved, seconded by **Council Member Lindsay** to amend claims to remove the payment to Mills, Scanlon, Dye and Pittman, Inc. in the amount of \$32,566.09. The motion failed by the following vote:

Yeas – Grizzell, Lee and Lindsay.
Nays – Banks, Foote and Hartley.
Absent – Stokes.

* * * * *

Note: Council Member Grizzell left the meeting.

* * * * *

After a thorough, **President Foote**, called for a vote of said item:

Yeas – Banks, Foote and Hartley.
Nays – Lee and Lindsay.
Absent – Grizzell and Stokes.

* * * * *

Note: Council Member Grizzell returned to the meeting.

* * * * *

President Foote recognized **Vice President Lee** who moved, seconded by **Council Member Hartley** to add an item to the agenda on an emergency basis, Order ratifying three emergency contracts with Lewis Electric, Inc. for traffic signal emergency repair work at Northside Drive and Boling Street; Watkins Drive and Valley North Boulevard; and Medgar Evers Boulevard and Ridgeway Street. The motion prevailed by the following vote:

Yeas – Banks, Foote, Grizzell, Hartley, Lee and Lindsay.
Nays – None.
Absent – Stokes.

* * * * *

There came on as the Emergency Agenda Item: ORDER RATIFYING THREE EMERGENCY CONTRACTS WITH LEWIS ELECTRIC, INC. FOR TRAFFIC SIGNAL EMERGENCY REPAIR WORK AT NORTHSIDE DRIVE AND BOLING STREET; WATKINS DRIVE AND VALLEY NORTH BOULEVARD; AND MEDGAR EVERS BOULEVARD AND RIDGEWAY STREET: Hearing no objections, the Clerk read the following:

ORDER RATIFYING THREE EMERGENCY CONTRACTS WITH LEWIS ELECTRIC, INC. FOR TRAFFIC SIGNAL EMERGENCY REPAIR WORK AT NORTHSIDE DRIVE AND BOLING STREET; WATKINS DRIVE AND VALLEY NORTH BOULEVARD; AND MEDGAR EVERS BOULEVARD AND RIDGEWAY STREET.

WHEREAS, traffic signals at three locations: 1) Northside Drive and Boling Street; 2) Watkins Drive and Valley North Boulevard; and 3) Medgar Evers Boulevard and Ridgeway Street are in need of repair to restore their functionality; and

WHEREAS, due to the severity of the failures, the City of Jackson needed to hire a contractor to replace the damaged poles and make the necessary repairs to the traffic signals; and

WHEREAS, because of these public safety dangers, the Mayor invoked the emergency procurement process, pursuant to Section 31-7-13 (k), a copy of which is attached to this Order and made a part of these minutes; and

WHEREAS, pursuant to the emergency procurement process, the City received quotes from Lewis Electric, Inc., for an amount not to exceed \$24,450.00 for the repairs at Northside Drive; for an amount not to exceed \$26,475.00 for the repairs at Watkins Drive; and for an amount not to exceed \$24,925.00 for the repairs at Medgar Evers Boulevard, copies of which are attached to this Order and made a part of these minutes.

IT IS, THEREFORE, ORDERED that emergency contracts with Lewis Electric, Inc. for an amount not to exceed \$24,450.00 for the repairs at Northside Drive; for an amount not to exceed \$26,475.00 for the repairs at Watkins Drive; and for an amount not to exceed \$24,925.00 for the repairs at Medgar Evers Boulevard are ratified.

REGULAR MEETING OF THE CITY COUNCIL
TUESDAY, FEBRUARY 28, 2023 10:00 A.M. 711

**DECLARATION INVOKING THE EMERGENCY
PROCUREMENT PROCEDURE**

I. REQUEST

Over the past month, traffic signals have been damaged and are in need of repair at the following locations:

Baldwin Road and Sheriff Drive,
Bailey Avenue Extension and Myers Street,
Watkins Drive and Valley North Boulevard,
Northside at Boling,
Medgar Evers and Ridgeway, and
adjoin Barbours at Northside Drive and at Bailey Avenue Extension

Currently, traffic engineering lacks the materials, equipment, and personnel to repair the traffic signals at all of these locations. Leaving these signals creates a public safety hazard to motorists.

Accordingly, I request that you declare that this situation constitutes an "emergency" as that term is defined in Section 31-7-1 of the Mississippi Code Annotated of 1972, as amended, and authorize contracts to make repairs to the damaged traffic signals, pursuant to Section 31-7-13 (k) of the Mississippi Code Annotated of 1972, as amended.

As background information to assist in your determination that an emergency exists, I have attached a memorandum from Robert Lee, City Engineer. I have also obtained the review and approval of the Office of the City Attorney, the Chief Financial Officer, and the Chief Administrative Officer as evidenced by the signatures below.

Robert Lee
City Engineer

2/3/2023
DATE

II. REVIEWED AND APPROVED

Toni Martin
City Attorney

2/3/23
DATE

Paula Matherly
Chief Financial Officer

02/06/23
DATE

Laura Wright
Chief Administrative Officer

2/6/23
DATE

III. DECLARATION OF EMERGENCY

I hereby determine that damaged traffic signals at the certain locations constitute an emergency as that term is defined under Section 31-7-1 of the Mississippi Code Annotated of 1972, as amended, so that the delay incident to giving opportunity for competitive bidding would be detrimental to the interest of the City of Jackson, Mississippi and its citizens, and that contracts to make repairs to certain damaged traffic signals to local streets, are authorized pursuant to Section 31-7-13 (k) of the Mississippi Code Annotated of 1972, as amended.

Accordingly, this request is approved, effective November 1, 2022.

CHRISTINE A. LUMUMBA
Mayor

2/6/2023
DATE

LEWIS ELECTRIC, INC.

P.O. BOX 320337
FLOWOOD, MS 39232-0337
601-932-0101 / 601-709-0866 (FAX)
FED ID #64-0823637

QUOTE

DATE	QUOTE #
4/21/2023	23042101

PROJECT NAME/LOCATION	
NORTHBROOK @ BOILING JACKSON MS	

QTY	Description	UNIT	PRICE	TOTAL
1.00	Signal Repairs at Northbrooke Drive and Boiling	LS	\$ 24,000.00	\$ 24,000.00
	Includes:			
	New Wood Pole			
	(1) Type 2 Heads			
	(1) Type 3 Heads			
	Repair Span Wires and Signal Cables			
TOTAL ITEMS:				\$ 24,000.00

NOTES:
1.00 Lewis Electric is a certified WBE Contractor
2.00 Bonded/Insured by Borealis/Travelers Insurance

Daniel Steadham

Daniel Steadham / Estimator
601-586-2391 / 601-852-0300

LEWIS ELECTRIC, INC.

P.O. BOX 320337
FLOWOOD, MS 39232-0337
601-932-0101 / 601-709-0866 (FAX)
FED ID #64-0823637

QUOTE

DATE	QUOTE #
4/21/2023	23042102

PROJECT NAME/LOCATION	
WATKINS @ VALLEY NORTH JACKSON MS	

QTY	Description	UNIT	PRICE	TOTAL
1.00	Signal Repairs at Watkins Dr. and Valley North	LS	\$ 26,475.00	\$ 26,475.00
	Includes:			
	New Wood Pole			
	Stringtree Existing Cabinet (8' tall Working)			
	(1) Type 3 Heads			
	Repair Span Wires and Signal Cables			
TOTAL ITEMS:				\$ 26,475.00

NOTES:
1.00 Lewis Electric is a certified WBE Contractor
2.00 Bonded/Insured by Borealis/Travelers Insurance

Daniel Steadham

Daniel Steadham / Estimator
601-586-2391 / 601-852-0300

LEWIS ELECTRIC, INC.

P.O. BOX 320337
FLOWOOD, MS 39232-0337
601-932-0101 / 601-709-0866 (FAX)
FED ID #64-0823637

QUOTE

DATE	QUOTE #
4/21/2023	23042103

PROJECT NAME/LOCATION	
MEDGAR EYERS @ RIDGEWAY JACKSON MS	

QTY	Description	UNIT	PRICE	TOTAL
1.00	Signal Repairs at Medgar Evers and Ridgeway	LS	\$ 24,825.00	\$ 24,825.00
	Includes:			
	New Wood Pole			
	(1) Type 3 Heads			
	(1) Type 4 Heads			
	(1) Type 2 Head			
	(1) Type 2 Head (prevent marking tape 2)			
	Repair Span Wires and Signal Cables			
TOTAL ITEMS:				\$ 24,825.00

NOTES:
1.00 Lewis Electric is a certified WBE Contractor
2.00 Bonded/Insured by Borealis/Travelers Insurance

Daniel Steadham

Daniel Steadham / Estimator
601-586-2391 / 601-852-0300

Vice President Lee moved adoption; Council Member Grizzell seconded.

President Foote recognized Robert Lee, Interim Director of Public Works, who provided a brief overview of said item.

Thereafter, **President Foote**, called for a vote of said item:

Yeas – Banks, Foote, Grizzell, Hartley, Lee and Lindsay.

Nays – None.

Absent – Stokes.

* * * * *

President Foote recognized **Council Member Lindsay** who moved, seconded by **Vice President Lee** to add an item to the agenda on an emergency basis, Order amending the fiscal year 2022-2023 budget for the City of Jackson Fire Department in order to transfer funds for the procurement of one (1) Dodge Durango SUV to be used by the Deputy Fire Chief of the emergency services division. The motion prevailed by the following vote:

Yeas – Banks, Foote, Grizzell, Hartley, Lee and Lindsay.

Nays – None.

Absent – Stokes.

* * * * *

There came on as the Emergency Agenda Item: ORDER AMENDING THE FISCAL YEAR 2022-2023 BUDGET FOR THE CITY OF JACKSON FIRE DEPARTMENT IN ORDER TO TRANSFER FUNDS FOR THE PROCUREMENT OF ONE (1) DODGE DURANGO SUV TO BE USED BY THE DEPUTY FIRE CHIEF OF THE EMERGENCY SERVICES DIVISION: Hearing no objections, the Clerk read the following:

ORDER AMENDING THE FISCAL YEAR 2022-2023 BUDGET FOR THE CITY OF JACKSON FIRE DEPARTMENT IN ORDER TO TRANSFER FUNDS FOR THE PROCUREMENT OF ONE (1) DODGE DURANGO SUV TO BE USED BY THE DEPUTY FIRE CHIEF OF THE EMERGENCY SERVICES DIVISION.

WHEREAS, Section 21-17-5(1) of the Mississippi Code Annotated, as amended, states that the governing authorities of every municipality of the state shall have the care, management, and control of its municipal affairs, property, and finances; and

WHEREAS, the public health, safety, and welfare of the citizens of the City of Jackson mandates that there be adequate resources available to respond to emergencies; and

WHEREAS, certain unbudgeted needs have arisen since the adoption of the Fiscal Year 2022-2023 City of Jackson Fire Department Budget; and

WHEREAS, the City of Jackson Fire Department has a need for one (1) Dodge Durango SUV to be used by the Deputy Fire Chief of the Emergency Services Division; and

WHEREAS, the Deputy Fire Chief of the Emergency Services Division is on-call at nearly all times and needs a reliable and durable vehicle so that he can quickly and safely respond to fire and other emergencies; and

WHEREAS, the procurement of said vehicle serves the best interests of the public’s health, safety, and welfare; and

WHEREAS, the procurement of said vehicle was not included in the Fiscal Year 2022-2023 City of Jackson Fire Department Budget, therefore a Budget amendment is needed to reallocate funds within said Budget to make the procurement; and

WHEREAS, there are funds available in the “Other Professional Services” category of the Fiscal Year 2022-2023 City of Jackson Fire Department Budget which may be used for this procurement if said Budget is amended; and

WHEREAS, Section 21-35-25 of the Mississippi Code Annotated, as amended, states that if it affirmatively appears at any time during the current fiscal year that there is in any fund or account any sum remaining unexpended and not needed or expected to be needed for the purpose or purposes for which appropriated in said budget, then the governing authorities may, in their discretion, transfer such sum or any part thereof to any other fund or funds or account or accounts where needed, by order to such effect

entered upon their minutes. This shall not, however, authorize the expenditure of any funds for any purpose other than that for which the levy producing such funds was made; and

WHEREAS, pursuant to Mississippi purchasing laws, two (2) written competitive quotes for the purchase of said vehicle were obtained from Mac Haik Jackson Ford and Massey Automotive Group; and

WHEREAS, pursuant to Mississippi purchasing laws, the City of Jackson Fire Department has selected Mac Haik Jackson Ford as the vendor because it provided the lowest and best quote for the purchase of said vehicle; and

WHEREAS, the interests of public health, safety, and welfare would best be served by authorizing a Budget transfer of Forty-Five Thousand Dollars (\$45,000.00) from Fund 001.441.20.6419 (“Other Professional Services”) to Fund 001.441.20.6868 (“Automobiles & Pickup Trucks”), to be allocated as follows:

Amount:	From Fund:	To Fund:
\$45,000.00	001.441.20.6419 (“Other Professional Services”)	001.441.20.6868 (“Automobiles & Pickup Trucks”)

WHEREAS, the City of Jackson Fire Department represents that the Forty-Five Thousand Dollars (\$45,000.00) currently located in “Other Professional Services” is not needed or expected to be needed for the purpose(s) for which it was originally appropriated in the Fiscal Year 2022-2023 City of Jackson Fire Department Budget; and

WHEREAS, this intradepartmental transfer of Forty-Five Thousand Dollars (\$45,000.00) is in statutory compliance with Section 21-35-25 of the Mississippi Code Annotated, as amended, because the transfer requested in this Order, added to any previous Fiscal Year 2022-2023 City of Jackson Fire Department Budget intradepartmental transfers, does not exceed ten percent (10%) of the total budget amount appropriated to the Fiscal Year 2022-2023 City of Jackson Fire Department Budget; thus.

IT IS, THEREFORE, ORDERED that the Fiscal Year 2022-2023 Budget of the City of Jackson Fire Department be amended to authorize a Budget transfer of Forty-Five Thousand Dollars (\$45,000.00) from Fund 001.441.20.6419 (“Other Professional Services”) to Fund 001.441.20.6868 (“Automobiles & Pickup Trucks”), to be allocated as follows:

Amount:	From Fund:	To Fund:
\$45,000.00	001.441.20.6419 (“Other Professional Services”)	001.441.20.6868 (“Automobiles & Pickup Trucks”)

IT IS FURTHER ORDERED that the Forty-Five Thousand Dollars (\$45,000.00), once transferred to Fund 001.441.20.6868 (“Automobiles & Pickup Trucks”), be used to procure one (1) Dodge Durango SUV from Mac Haik Jackson Ford pursuant to the winning quote identified above in this Order to be used by the Deputy Fire Chief of the Emergency Services Division.

IT IS FURTHER ORDERED that the Mayor be authorized to execute any and all documents associated with the procurement of the above Dodge Durango SUV.

Council Member Lindsay moved adoption; **Vice President Lee** seconded.

President Foote recognized **Elliot Holmes, Deputy Chief of the Jackson Fire Department**, who provided a brief overview of said item.

Thereafter, **President Foote**, called for a vote of said item:

- Yeas – Banks, Foote, Grizzell, Hartley, Lee and Lindsay.
- Nays – None.
- Absent – Stokes.

* * * * *

ORDER CONFIRMING THE MAYOR'S TEMPORARY APPOINTMENT OF ROBERT LEE AS DIRECTOR OF THE DEPARTMENT OF PUBLIC WORKS, CITY OF JACKSON, MISSISSIPPI.

WHEREAS, on or about February 10, 2023, the Mayor appointed Robert Lee as Interim Director of the Department of Public Works for the City of Jackson, Mississippi; and

WHEREAS, pursuant to Miss. Code Ann. §21-15-41, Mississippi Code of 1972, as amended, the interim term of Robert Lee as Public Works Director will expire May 11, 2023, upon expiration he can no longer serve in an interim capacity; and

WHEREAS, on February 28, 2023, the City Council authorized the City of Jackson to enter into an agreement with GovHR USA LLC to provide professional recruiting services to the City of Jackson to employ a Public Works Director; and

WHEREAS, on GovHR USA LLC has worked diligently with the City of Jackson to develop and issue advertising materials to recruit a Public Works Director, but the City has not yet received a list of qualified interested applicants for the position; and

WHEREAS, the temporary appointment came before the City Council for confirmation as required by Section 21-8-23(2), Mississippi Code of 1972, as amended; and

WHEREAS, the appointment of Robert Lee will be temporary and shall expire at the time a new Public Works Director is presented to the City Council for confirmation as a result of the recruitment efforts of GovHR USA LLC; and

WHEREAS, the City Council has considered the temporary appointment, and a majority of the Council present and voting has determined that the appointment should be confirmed.

IT IS, THEREFORE, ORDERED by the City Council of the City of Jackson, Mississippi, that the appointment of Robert Lee as Director of the Department of Public Works for the City of Jackson, Mississippi, is hereby confirmed.

Vice President Lee moved adoption; **Council Member Lindsay** seconded.

President Foote recognized **Catoria Martin, City Attorney and Toya Martin, Director of Human Resources**, who provided a brief overview of said item.

Thereafter, **President Foote**, called for a vote of said item:

Yeas – Foote, Grizzell, Lee and Lindsay.

Nays – Banks and Hartley.

Absent – Stokes.

* * * * *

ORDER RATIFYING CONTRACTS RELATED TO THE EMERGENCY REPAIRS TO THALIA MARA HALL AND THE ARTS CENTER OF MISSISSIPPI IN PREPARATION FOR THE U.S.A. INTERNATIONAL BALLET COMPETITION.

WHEREAS, the City of Jackson Department of Public Works and Department of Human and Cultural Services are currently in the process of preparing Thalia Mara Hall and the Arts Center of Mississippi for the USA International Ballet Competition ("USA IBC"); and

WHEREAS, the USA IBC is a two-week Olympic-style competition for top young dancers from all over the world, which occurs every four (4) years in the City of Jackson and is scheduled to take place June 10, 2023 through June 24, 2023; and

WHEREAS, the 2018 USA IBC was attended by more than 44,000 people generating a combined economic impact of \$12.5 million for the City of Jackson and the State of Mississippi; and

WHEREAS, the USA IBC is scheduled to begin June 10, 2023 and there are necessary repairs which must take place at both Thalia Mara and the Arts Center of Mississippi prior to June 10, 2023; and

WHEREAS, the City of Jackson previously contracted with Cooke Douglass Farr Lemons ("CDFL") to produce a scope of work for Thalia Mara Hall; and

WHEREAS, the City has contracted Canizaro Cawthon Davis, A Professional Association to produce a scope of work for the Arts Center of Mississippi, which scope is to include an update to the existing public restrooms to bring them into compliance with the ADA due to performance issues with Construction Specialists, LLC, which recently caused the City to terminate that construction agreement; and

WHEREAS, the City has authorized a contract with Benchmark Construction Corporation, whose principal office address is 1867 Crane Ridge Drive #200A, Jackson, MS 39216, to provide general contractor services to assist the City of Jackson with completing the proposed scope of work for Thalia Mara Hall by June 1, 2023; and

WHEREAS, pursuant to Miss. Code Ann. § 31-7-13(k), due to the threat of economic loss based on the restricted time period, limitations of available equipment, materials and delivery schedules, and to protect and preserve the facilities, the City of Jackson invoked the emergency procurement procedure for the intended repairs to Thalia Mara and the Arts Center, a copy of which is attached hereto; and

WHEREAS, pursuant to the emergency procurement process, the following proposals have been accepted for work or materials, which constitute a contract for the work, a copy of said contracts being attached to this Order and made a part of the minutes of this meeting:

Vendor	Services/ Materials	Amount
Capitol Hardware	Lock Cylinders	\$ 11,250.00
A Plus Signs & Creative	Signs	\$ 10,293.50
Big John's Tree Service	Tree Trimming	\$ 300.00
J.L. Roberts Mechanical, LLC	Plumbing Repairs	\$ 3,625.00
ADCO Electrical	Flag Lights	\$ 19,650.00
ADCO Electrical	Add'l Track Heads	\$ 10,460.00
ADCO Electrical	Elevator Lobby Fixture	\$ 520.00
ADCO Electrical	Track, Light, Switch	\$ 1,210.00
Jani King	General Cleaning, Wash Interior & Exterior	\$ 8,370.00
Jani King	Scrub Ceramic Tile	\$ 990.00
Jani King	Carpet Extraction	\$ 2,304.00
Jani King	General Cleaning, Wash Interior & Exterior	\$ 500.00
Guaranteed Roofing	Leak Investigation	\$ 1,250.00
Total		\$ 70,722.50

IT IS, THEREFORE, ORDERED that the contracts for work listed in the proposals listed above at the amounts stated are hereby ratify.



April 17, 2023

Catoria P. Martin
City Attorney
City of Jackson, MS
Post Office Box 2779
Jackson, MS 39207

Re: Arts Center – Lock Cylinders

Dear Ms. Martin:

Please find attached a proposal from Capitol Hardware in the amount of \$11,250.00. I have reviewed the proposal and recommend it be accepted.

Please let me know if you have any questions.

Sincerely,

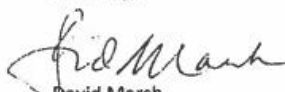
David Marsh,
President

Accepted by: 
City of Jackson, Mississippi



PROPOSAL

HARDWARE / BUILDING PRODUCTS
112 Business Park Dr. Ridgeland, MS 39157

ISSUE DATE: 4/14/23

TO: CITY OF JACKSON
C/O BENCHMARK CONST. MGMT.
ATTN: DAVE MARCH

JOB: ARTS CENTER
JACKSON, MS.

WE PROPOSE TO FURNISH THE FOLLOWING MATERIAL FOR THE SUM OF \$ 11,250.00

ELEVEN THOUSAND TWO HUNDRED FIFTY & NO/100-----

- FOR EXISTING DOORS
- (1) LOT NEW CYLINDERS PER SURVEY OF 4/13/23 - STEVE DAVIS & OWNER REPS
- (1) NEW KEY CABINET
- (1) NEW LOCK FOR #110A
- (1) LOT INSTALLATION OF CYLINDERS & NEW LOCK
- (1) LOT LUBRICATION OF EXISTING INTERIOR LOCKS
- (3) SETS OF NEW KNOBS /SPINDLES FOR EXISTING MORTISE LOCKS

THANKS AND PLEASE ADVISE IF WE ARE TO PROCEED.



OWNER TO PROVIDE REQ'D KEYING SCHEDULE WITHIN THE NEXT COUPLE OF DAYS

EXCLUSIONS

EXISTING FRAME AND /OR EXISTING DOOR REPAIR

Terms are net 30 days of delivery, without retainage, and plus any and all applicable taxes; FOB warehouse with freight allowed to motor freight station nearest job site. Delivery to carrier shall constitute delivery to purchaser. This proposal is subject to acceptance within 30 days, or before earlier withdrawal by Seller. Installation and/or allowances are not included in the above pricing unless otherwise noted.

Accepted:

By:

CHARLES D. STACY

Date:

CAPITOL HARDWARE COMPANY, INC.



April 24, 2023

Catoria P. Martin
City Attorney
City of Jackson, MS
Post Office Box 2779
Jackson, MS 39207

Re: Thalia Mara, Signs

Dear Ms. Martin:

Please find attached a proposal from A Plus Signs & Creative in the amount of \$10,293.50. I have reviewed the proposal and recommend it be accepted.

Please let me know if you have any questions.

Sincerely,

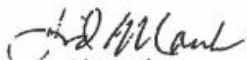
David Marsh,
President

Accepted by: 
City of Jackson, Mississippi



SIGNS & CREATIVE

QUOTE & PURCHASE CONTRACT

A Plus Signs and Creative
Job #1321
04/14/2023

Michaela Fisk
Office Phone: 601-355-9995
Email: mfisk@aplusigns.com

BILL TO
City of Jackson
200 South Presidents St
Suite 424
Jackson, MS 39205
United States

JOB LOCATION
Thalia Mara Hall

5830 N State Street
Jackson, MS 39209
United States
Phone: 601.309.9595

QUANTITY	DESCRIPTION	UNIT COST	COST
1	Dimensional Halo-Lighted Channel Letters Approx 2' tall aluminum letters, painted black	\$6,768	\$6,768
1	Mounting Cabinet Non-lit cabinet for install of letters	\$2,145.50	\$2,145.50
1	Install	\$1,295	\$1,295
1	Permit Filing Fee	\$85	\$85

THIS AGREEMENT IS ACCEPTED AND APPROVED BY:

Subtotal \$10,293.50

Total Tax \$0

City of Jackson

A Plus Signs and Creative

Sign: _____

Sign: _____

Print: _____

Print: _____

Date: _____

Date: _____

TOTAL CONTRACT \$10,293.50

Required Deposit \$5,146.75

FINAL BALANCE \$5,146.75

Quotes are only valid for 30 days. By signing, Customer accepts Company's proposal for the Job and agrees to all of the terms of the purchase contract.

For an approved job to move forward a 50% deposit is required along with approval on all artwork and the signed contract. Accepted forms of payment are Credit Card(3.5% fee), ACH (\$10 fee), and Check. If paying by check, please make all checks payable to: A Plus Signs and Creative. Remaining balances are due upon install/deliver. In order to set up alternative terms (i.e. 30 days) you must reach out to your project manager at the time of deposit.



SIGN PROOF FOR APPROVAL
Emily Henson - 4/11/23

Thalia Mara Hall

THALIA MARA HALL made as halo lit channel letters.
white faces and 2" white returns. Channels will be
mounted to cabinet with 2" spacers
Channel letters are mounted to nonlit cabinet. Cabinet
will have black faces and 2" black return.
Non lit cabinet mounted to granite tile



Please review carefully. If any errors, no responsibility will be held. If revisions are requested, please email us. If the client approves, a signature and email from approval indicates that with the completion of all noted corrections, we will not be held responsible for any errors.

This design is property of A Plus Signs & Creative and for its use only.



April 24, 2023

Catoria P. Martin
City Attorney
City of Jackson, MS
Post Office Box 2779
Jackson, MS 39207

Re: Thalia Mara, Tree Trimming

Dear Ms. Martin:

Please find attached a proposal from Big John's Tree Service in the amount of \$300.00. I have reviewed the proposal and recommend it be accepted.

Please let me know if you have any questions.

Sincerely,

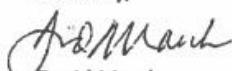
David Marsh,
President

Accepted by: 
City of Jackson, Mississippi



Big John's Tree Service
P.O. Box 321064
Flowood, MS 39232
(601) 941-7773

JOHNNIE ROLAND
Owner

Big John's Tree Service does hereby contract with Benchmark Construction - Thalia Mara Hall,
Owner, of the subject property (listed below), to perform such specific services as listed below. The contract price
is \$ 300.00. Full payment is due in full upon completion of services.

SUBJECT PROPERTY ADDRESS

Address: 255 E Pascagoula Street Phone: Max Marsh - 601-454-5622
City/State/Zip: Jackson, MS 39201 Email: mdmarsh11@gmail.com

SPECIFIC SERVICES TO BE PERFORMED

Take Down & Haul Off (3) Loripedlum on East side of building.

[Redacted area]

I Understand that taking trees down is a construction process and some damage may occur to the yard and landscape.
 I Understand that **Big John's Tree Service** is not liable for any underground utilities unless property marked.

Client's Signature: _____ Date: _____
Representative: Kenneth Anderson Date: 04.13.23



April 25, 2023

Catoria P. Martin
City Attorney
City of Jackson, MS
Post Office Box 2779
Jackson, MS 39207

Re: Thalia Mara – Plumbing Repairs

Dear Ms. Martin:

Please find attached a proposal from J. L. Roberts Mechanical in the amount of \$3,625.00. I have reviewed the proposal and recommend it be accepted.

Please let me know if you have any questions.

Sincerely,

A handwritten signature in blue ink that reads 'David Marsh'.

David Marsh,
President

Accepted by: A handwritten signature in blue ink, appearing to be 'C. L. ...', written over a horizontal line.
City of Jackson, Mississippi



PROPOSAL

COMPANY	Benchmark Construction	DATE	March 22, 2023
CONTACT	David Marsh	CR #	13941-MC
PROJECT	Thalia Mara Hall		

SCOPE OF WORK

Plumbing

- Correct orientation of lavatory faucets as directed during site visit.
- Repair/Replace 5 water closet flush valves as directed during site visit.

HVAC

- NONE

Not Included

Bond, dumpster, water proofing, latent conditions discovered during construction, painting of any kind, patching of walls, floors, ceiling. asbestos testing/abatement

PRICING

PRICE INCLUDING TAX:	\$3,625.00

ACCEPTANCE

<p>This proposal may be withdrawn by J.L. Roberts Mechanical if not accepted within 30 days.</p> <p>PROPOSAL ACCEPTANCE The above prices, specifications and conditions are satisfactory and are hereby accepted. J.L. Roberts Mechanical is authorized to perform the work as specified. Payment will be made as outlined in the contract documents.</p>	<p>David Graves</p> <p><i>J.L. Roberts Mechanical Authorized Representative</i></p>
--	--



April 24, 2023

Catoria P. Martin
City Attorney
City of Jackson, MS
Post Office Box 2779
Jackson, MS 39207

Re: Thalia Mara, Flag Lights

Dear Ms. Martin:

Please find attached a proposal from ADCO Electric in the amount of \$19,650.00. I have reviewed the proposal and recommend it be accepted.

Please let me know if you have any questions.

Sincerely,

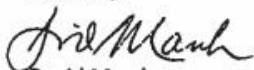
David Marsh,
President

Accepted by: 

City of Jackson, Mississippi

PROPOSAL

Date: 4/27/23

To: David Marsh

c/o Benchmark Construction Management

Re: **TMH New Work to Light up New Flag Poles at East Entry**

David,

We are pleased to provide our price to illuminate the (3) new 60' Flag Poles to be located at the East Entry of Thaila Mara Hall in time for the start of the IBC Competition in June of this year. Our proposal includes (9) total lights specifically designed for Flagpole lighting at the heights of these poles and projected Flag sizes, they will carry. Our price including Tax for this installed work is: \$ 19,660

Please advise if we are to proceed with this new work and we will order the lights and equipment as needed.

Please note this is a time-sensitive proposal in order for us to be able to order and receive the special 50,000 Lumen lights required for this work; therefore our proposal is only good for 7 calendar days from date of this proposal.

Respectfully submitted,

Andy Hardin, VP

Adco Electric, Inc.

ADCO ELECTRIC INC.
CONTRACTORS ENGINEERS



Adco Electric Inc.
P.O. Box 7395
Jackson, MS 39282-7395

CCN # 1
Date: 4/19/2023
Project Name: THALIAMARAHALLLIGHTRENOVATIONS
Project Number: THALIAMARAHALLLIGHTRENOVATIONS
Page Number: 1

ClientAddress:

BENCHMARK CONSTRUCTION
Contact: DAVID MARSH
1867 CRANE RIDGE ROAD
SUITE 200A
JACKSON, MS 39216

Work Description

CCN#01; COP to add (9) Flag Pole lights to new location of (3) 60' Flag Poles to be located on the East Side of TMH behind the existing Statue. Lights will be circuited through the same power source as the Statue, but the Statue lights will be RGB type for color changing. Flag Pole Lights are only 5000K color (White) light.

We reserve the right to correct this quote for errors and omissions.
This quote covers direct costs only and we reserve the right to claim for impact and consequential costs.
This price is good for acceptance within 10 days from the date of receipt.
We request a time extension of 3 days.

Itemized Breakdown

Description	Qty U	Total Mat.	Labor U	Total Hrs.
Flag Mount flood	9E	0.00	4.22 E	37.98
2" CONDUIT - RMC - GALV	23C	315.38	11.00 C	2.48
3/4" ELBOW 90 DEG - RMC - GALV	12C	82.81	40.00 C	4.80
3/4" LOCKNUT - STEEL	8C	3.20	2.88 C	0.23
3/4" CONDUIT - PVC40	160C	181.02	4.50 C	7.20
3/4" COUPLING - PVC	6C	1.20	0.00 C	0.00
3/4" ADAPTER MALE - PVC	8C	4.18	16.00 C	1.28
3/4" ADAPTER FEM - PVC	24C	9.04	16.00 C	3.84
PVC CEMENT STANDARD (1-PINT)	1E	12.62	0.63 E	0.63
#10 THHN BLACK	180M	46.50	7.00 M	1.26
#10 THHN WHITE	180M	46.50	7.00 M	1.26
#10 THHN GREEN	180M	46.50	7.00 M	1.26
WIRE CONN RED	27C	6.89	7.50 C	2.02
6x 6x 6" J-BOX W/ CVR NO HUBS - PVC	1C	52.38	45.00 C	0.45
FIXTURE LENS	9E	0.00	0.13 E	1.17
FIXTURE SLIP FIT ASSEMBLY	9E	0.00	0.25 E	2.25

ORIGINAL

**REGULAR MEETING OF THE CITY COUNCIL
TUESDAY, MAY 9, 2023 10:00 A.M.**

Adco Electric Inc. P. O. Box 7395 Jackson, MS 39282-7395	Client Address: BENCHMARK CONSTRUCTION 1867 CRANE RIDGE ROAD SUITE 200A JACKSON, MS 39216	CCN # 1 Date: 4/19/2023 Project Name: THALIAMARAHALLIGHTRE Project Number: THALIAMARAHALLIGHTRE Page Number: 2
---	--	---

Description	Qty U	Total Mat.	Labor U	Total Hrs.
ST AN CH ION PEDESTAL	9E	0.00	4.00E	36.00
BAG OF QUICKCRETE	9E	45.00	0.50E	4.50
TRENCHING 3' X 6"	90E	0.00	1.25C	1.13
BACKFILL 3' X 6"	90E	0.00	3.30C	2.97
ex staurte light replace for new flag light circu	1E	0.00	2.50E	2.50
Totals	1,036	853.24		115.21

Summary

General Materials		853.24
FIXTURES		10,932.12
Material Total		11,785.36
LABOR		
ELECTRICIAN	(57.61 Hrs @ \$46.50)	2,678.87
APPRENTICE	(57.61 Hrs @ \$38.10)	2,194.94
Indirect Job Cost		
CONSUMABLES & MISCELLANEOUS	(853.24 @ 0.00 @ \$0.03 + 0.000 % + 0.000 % + 0.000 %)	25.60
CLEAN-UP	(115.22 @ 0.00 @ \$0.05 + 0.000 % + 0.000 % + 0.000 %)	5.76
SAFTEY MEETINGS	(115.22 @ 0.00 @ \$0.01 + 0.000 % + 0.000 % + 0.000 %)	1.15
SMALL TOOLS	(115.22 @ 0.00 @ \$0.45 + 0.000 % + 0.000 % + 0.000 %)	51.85
WARRANTY	(853.24 @ 0.00 @ \$0.03 + 0.000 % + 0.000 % + 0.000 %)	25.60
Total Indirect Job Cost		109.96
Equipment		
TRENCHER-WALK BEHIND (DAILY)	(1.00 @ 0.00 @ \$155.00 + 8.000 % + 0.000 % + 0.000 %)	167.40
TAMPER (DAILY)	(1.00 @ 0.00 @ \$72.00 + 8.000 % + 0.000 % + 0.000 %)	77.78
Total Equipment		245.16
Subtotal		17,014.29
Overhead	(@ 10.000 %)	1,701.43
Markup	(@ 5.000 %)	935.79
Subtotal		19,651.51
Final Adjustment		-1.51
Final Amount		\$19,650.00

CONTRACTOR CERTIFICATION

Name:	
Date:	
Signature:	
I hereby certify that this quotation is complete and accurate based on the information provided.	

CLIENT ACCEPTANCE

ORIGINAL

REGULAR MEETING OF THE CITY COUNCIL
TUESDAY, MAY 9, 2023 10:00 A.M.

Adco Electric Inc.
P.O. Box 7395
Jackson, MS 39282-7395

Client Address:
BENCHMARK CONSTRUCTION
1887 CRANE RIDGE ROAD
SUITE 200A
JACKSON, MS 38216

CCN # 1
Date: 4/19/2023
Project Name: THALIA MARA HALL LIGHTRE
Project Number: THALIA MARA HALL LIGHTRE
Page Number: 3

CCN #: 1	_____
Final Amount: \$19,850.00	_____
Name:	_____
Date:	_____
Signature:	_____

I hereby accept this quotation and authorize the contractor to complete the above described work.

ORIGINAL

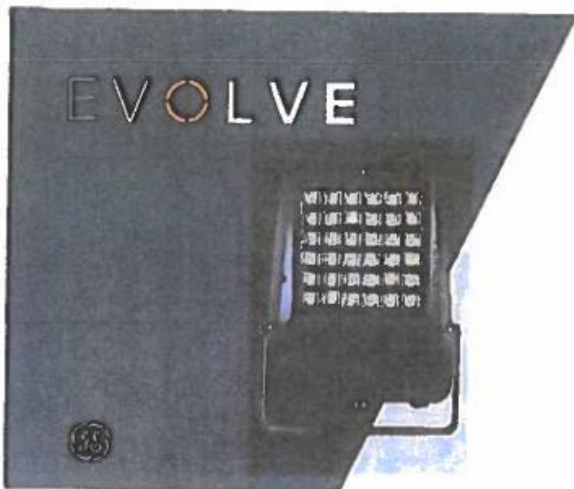

CUSTOMER NAME _____
Project Name _____
Date _____ Type _____
Catalog Number _____

EFH Series
High Output LED Flood Light
Mounting & Accessories

Construction

Housing: Aluminum die cast enclosure.
Integral heat sink for maximum heat transfer
Lens: Impact resistant tempered glass
Paint: Corrosion resistant polyester powder paint,
minimum 2.0 mil thickness
Standard = Black, Dark Bronze, Gray, White
(RAL & custom colors available)
Optional = Coastal Finish
Weight: 35 lbs (15.9 kgs)

Optical system

Lumens: 23,400 - 58,000
Distribution: 3x3, 6x6, 6x8, 7x8, 7x7
Efficacy: 121 -184 LPW
CCT: 2700K, 3000K, 4000K, 5000K
CRI: ≥70

Electrical

Input Voltage: 120-277V, 277-480V
Input Frequency: 50/60 Hz
Power Factor: ≥ 90% at rated watts
Total Harmonic Distortion: ≤ 20% at rated watts

Surge Protection

Typical	Enhanced	Extreme
<input type="checkbox"/> 6kV/3kA*	<input type="checkbox"/> 10kV/5kA*	<input type="checkbox"/> 20kV/10kA*

*Per ANSI C136.8-2018

Warranty

5 Year (Standard) 10 Year (Optional)

Lumen Maintenance

Projected Lx per IES TM-21-11 at 25°C

Lumen Codes	Distribution	LXX(LUX) @ Hours		
		25,000 HR	50,000 HR	65,000 HR
30, 35, 40, 45, 50	77, 78, 87, 88, 85	L97	L94	L93
30, 35, 40, 45, 50	33	L96	L94	L94
55	77, 78, 88, 85	L96	L92	L91
80	77, 78, 88	L96	L92	L90

Note: Projected Lx based on LM80 (> 10,000 hour testing). Accepted industry tolerances apply to initial luminous flux and lumen maintenance measurements.

Luminaire Ambient Temperature Factor

Ambient Temp (°C)	Adjusted Lumen Factor	Ambient Temp (°C)	Adjusted Lumen Factor
10	1.02	30	0.99
20	1.01	40	0.98
25	1.00	50	0.97

Ratings

Operating Temperature: -40° C to 50° C
Vibration*: 2G - Splitter Mounting K1, K2, S1 & S2
3G - Trunnion Mounting T1
LM-79: Testing in accordance with IESNA Standards

*Per ANSI C136.31-2010

Controls

Dimming: Standard - 0-10V
Optional - DALI (Option U)
Sensors: Photo Electric Sensors (PE) available
LightGrid and Daintree Compatible



Visit www.etglights.org/search to confirm qualifications.



document.com/brands/evolve

© 2022 Current Lighting Solutions, U.S. All rights reserved. GE and the GE monogram are trademarks of the General Electric Company and are used under license. Information and specifications subject to change without notice. All values are design or typical values when measured under laboratory conditions.

Page 1 of 8
(Rev February 21, 2023 10:23 AM)
OLP3191_R03



CUSTOMER NAME

Project Name _____
Date _____ Type _____
Catalog Number _____

Ordering Information

EFH1 02

7

PROP ID	QTY	VOLTAGE	LENGTH	SP. MOUNTING	LED	CCT	RECEPTACLE	CONTROL	TERMINAL	COLOR	OPTIONS
Evolve	02	0 = 120-277V ¹	30 = 30,000 lm	33 = NEMA 2x3	1 = 0	27 = 2700K	A = ANSI C136.41 7-Pin Receptacle ⁴	A = No Control	K1 = Knuckle splitter 1.8 in. - 2.3 in OD	GRAY = Gray	F = Push ²
High Flood Light	1	1 = 120V	35 = 35,000 lm	55 = NEMA 6x5		30 = 3000K	D = No receptacle, with external dimming 18/2 3 ft cable	D = Shoring Cap ⁶	K3 = Knuckle splitter 1.8 in. - 2.3 in OD Tenon Supplied with 14/3 3ft power cable	BLACK = Black	H2 = Dainzeq Enabled Motion Sensor ⁷
In Standard	2	2 = 208V	40 = 40,000 lm	66 = NEMA 6x6		40 = 4000K	H = No PE Receptacle & Non Dimmable	E = ANSI C136.41 7-pin with non-Dimming PE Control ⁸	E1 = Knuckle splitter 2.3-3.0 in. OD Tenon ⁴	DKBZ = Dark Bronze	H4 = Motion Sensor (FSP22) ⁴
	3	3 = 240V	45 = 45,000 lm	76 = NEMA 7x6		50 = 5000K	P = ANSI C136.41 7-Pin Receptacle with external dimming 18/2 3 ft cable ⁴		E2 = Knuckle splitter 2.3-3.0 in. OD Tenon, Supplied with 14/3 3ft power cable	WHITE = White	NOM = NOM3 ⁹
	4	4 = 277V	50 = 50,000 lm	77 = NEMA 7x7					T1 = Trunion with external 3ft 14/3 power cable		POB = Prewired with BR 14/3 cable
	5	5 = 480V	55 = 55,000 lm ¹⁰						V1 = Knuckle Wall Mount ⁵		R = 10kV/5kA Enhanced Surge Protection Device (SPD)
	D	D = 347V	60 = 60,000 lm ¹¹								T = 20kV/5kA Enhanced Surge Protection Device (SPD)
	E	E = 277-480V ¹									U = DALI Dimming ³
											VO = 3-Position Terminal Block
											V1 = FAM module
											Y = Coastal Finish ¹²

- NOTES
- ¹ Pushing requires discrete voltage
 - ² Not Available in 5x3 distribution
 - ³ Not Available in 6x6 distribution
 - ⁴ Installed aiming angle of 0-45°
 - ⁵ Can only be ordered with "A" or "P" Dimming Options
 - ⁶ Supplied with leads
 - ⁷ Not available in 347V, 480V OR 277-480V
 - ⁸ Only available in K1 or H1 mount
 - ⁹ Compatible with LightGrid System
 - ¹⁰ Recommended for installations within 750 feet from coast. Lead time varies, check with factory



gcurrent.com/brands/evolve

© 2022 Current Lighting Solutions, LLC. All rights reserved. GE and the GE monogram are trademarks of the General Electric Company and are used under license. Information and specifications subject to change without notice. All values are design or typical values when measured under laboratory conditions.

Page 3 of 6
(Rev February 21, 2023 10:23 AM)
OLP319L_R03



April 25, 2023

Catoria P. Martin
City Attorney
City of Jackson, MS
Post Office Box 2779
Jackson, MS 39207

Re: Arts Center – Additional Track & Heads

Dear Ms. Martin:

Please find attached a proposal from Adco Electric in the amount of \$10,460.00. I have reviewed the proposal and recommend it be accepted.

Please let me know if you have any questions.

Sincerely,

A handwritten signature in blue ink that reads 'David Marsh'.

David Marsh,
President

Accepted by:

A handwritten signature in blue ink, appearing to be 'John', written over a horizontal line.

City of Jackson, Mississippi

ADCO ELECTRIC INC.
CONTRACTORS ENGINEERS



Adco Electric Inc.
P.O. Box 7395
Jackson, MS 39282-7395

CCN # 1
Date: 4/4/2023
Project Name: ARTS CENTER OF MISSISSIPPI RENOVATIONE
Project Number: ARTS CENTER OF MISSISSIPPI RENOVATIONE
Page Number: 1

Client Address:

BENCHMARK
Contact: DAVID MARSH
1867 CRANE RIDGE DRIVE
SUITE 200 A
JACKSON, MS 39216

Work Description

CCN#01; COP #01 as per CCD. Add Track and Heads to project Scope

We reserve the right to correct this quote for errors and omissions.
This quote covers direct costs only and we reserve the right to claim for impact and consequential costs.
This price is good for acceptance within 2 days from the date of receipt.
We request a time extension of 2 days.

Itemized Breakdown

Description	QtyU	Total Mat.	LaborU	Total Hrs.
H track 8ft length	4E	0.00	1.96E	7.84
1/2" CONDUIT - EMT	15C	8.85	4.50C	0.68
1/2" CONN SS STL - EMT	2C	0.54	8.00C	0.16
1/2" COUPLING SS STL - EMT	2C	0.56	4.00C	0.08
1/2 OR 3/4" SNAP CLOSE CLIP - BTM MN	2C	4.31	5.00C	0.08
1/2" FLEX - STEEL	28C	30.61	4.00C	1.12
1/2" STL FLEX CONN	10C	26.23	12.00C	1.20
#12 THHN BLACK	96M	26.94	8.00M	0.58
#12 THHN SOLID BLACK	62M	12.83	8.00M	0.37
#12 THHN SOLID WHITE	17M	3.44	6.00M	0.10
#12 THHN SOLID GREEN	17M	3.44	6.00M	0.10
#18/2C CL2 JKT T-STAT CBL	15M	4.29	14.00M	0.21
WIRE CONN RED	15C	4.79	7.50C	1.13
DEV BOX 2 1/2" DEEP 1/2" KO W/ EARS	1C	7.04	25.00C	0.25
4x 1 1/2" OCT BOX 1/2" KO	4C	18.19	30.00C	1.20
4x 1 1/2" SQ BOX COMB KO	1C	4.96	30.00C	0.30
4" SQ BLANK COVER	1C	2.07	8.00C	0.08
1 x 1 5/8x 12G STRUT GRN	30C	150.03	10.00C	3.00
#8 TO #10x 7/8 PLAS ANCHOR (3/16)	8C	200.80	15.00C	1.20

ORIGINAL

**REGULAR MEETING OF THE CITY COUNCIL
TUESDAY, MAY 9, 2023 10:00 A.M.**

Adco Electric Inc.
P.O. Box 7395
Jackson, MS 39282-7395

ClientAddress:
BENCHMARK
1867 CRANE RIDGE DRIVE
SUITE 200 A
JACKSON, MS 39216

CCN # 1
Date: 4/4/2023
Project Name: ARTS CENTER OF MISSISSIP
Project Number: ARTS CENTER OF MISSISSIP
Page Number: 2

Description	Qty U	Total Mat.	Labor U	Total Hrs.
1/4" THREADED ROD - PLTD	32 C	18.74	11.00 C	3.52
1/4-20 HEX NUT - PLTD STL	16 C	1.12	2.40 C	0.38
1/4" FLAT WASHER - PLTD STL	24 C	1.99	1.25 C	0.30
1/4x4 TGL BOLT SPRING WING P/H	8 C	3.24	12.00 C	0.96
#10x1 P/H SELF-TAP SCREW	8 C	0.78	5.50 C	0.44
#8x 1/2 WAFER HEAD SHEET MTL SCR	2 C	0.18	1.88 C	0.04
OLD WORK BOX MOUNT F-CLIPS (PR)	1 C	0.87	10.00 C	0.10
512 24" T-BAR BOX HNGR (CADDY)	4 C	48.22	18.75 C	0.75
4G9 T-BAR TWIST-ON FIXT SUPPORT (8 C	17.15	9.38 C	0.75
1G DECORATOR PLATE - 302 S/S	1 C	1.86	10.00 C	0.10
1000W/S/P SLIDE-TO-OFF INCAND DIMM	1E	99.86	0.50 E	0.50
TRACK LIVE END CONN FLUSH	4E	0.00	0.25 E	1.00
FLOOD TRACK FIXT	45E	0.00	0.65 E	29.25
50PAR/SP/S/HAL SPOTLAMP	20E	0.00	0.04 E	0.80
FIXTURE LENS	20E	0.00	0.13 E	2.60
FIXTURE SPECIAL LENS	20E	0.00	0.19 E	3.80
Totals	542	703.52		64.94

Summary

General Materials		703.52
FIXTURES		5,530.00
Material Total		6,233.52
LABOR		
ELECTRICIAN	(32.47 Hrs @ \$46.50)	1,509.86
APPRENTICE	(32.47 Hrs @ \$38.10)	1,237.11
Indirect Job Cost		
CONSUMABLES & MISCELLANEOUS	(703.52 @ 0.00 @ \$0.03 + 0.000 % + 0.000 % + 0.000 %)	21.11
CLEAN-UP	(64.94 @ 0.00 @ \$0.05 + 0.000 % + 0.000 % + 0.000 %)	3.25
SAFTEY MEETINGS	(64.94 @ 0.00 @ \$0.01 + 0.000 % + 0.000 % + 0.000 %)	0.65
SMALL TOOLS	(64.94 @ 0.00 @ \$0.45 + 0.000 % + 0.000 % + 0.000 %)	29.22
WARRANTY	(703.52 @ 0.00 @ \$0.03 + 0.000 % + 0.000 % + 0.000 %)	21.11
Total Indirect Job Cost		75.34
Subtotal		9,055.83
Overhead	(@ 10.000 %)	905.58
Markup	(@ 5.000 %)	498.07
Subtotal		10,459.48
Final Adjustment		0.52
Final Amount		\$10,460.00

CONTRACTOR CERTIFICATION

Name:	_____
Date:	_____
Signature:	_____

I hereby certify that this quotation is complete and accurate based on the information provided.

ORIGINAL

REGULAR MEETING OF THE CITY COUNCIL
TUESDAY, MAY 9, 2023 10:00 A.M.

Adco Electric Inc.
P.O. Box 7395
Jackson, MS 39282-7395

Client Address:
BENCHMARK
1867 CRANE RIDGE DRIVE
SUITE 200A
JACKSON, MS 39216

CCN # 1
Date: 4/4/2023
Project Name: ARTS CENTER OF MISSISSIP
Project Number: ARTS CENTER OF MISSISSIP
Page Number: 3

CLIENT ACCEPTANCE

CCN #: 1	_____
Final Amount: \$10,460.00	_____
Name:	_____
Date:	_____
Signature:	_____
<small>I hereby accept this quotation and authorize the contractor to complete the above described work.</small>	

ORIGINAL



April 25, 2023

Catoria P. Martin
City Attorney
City of Jackson, MS
Post Office Box 2779
Jackson, MS 39207

Re: Arts Center – Elevator Lobby Fixture

Dear Ms. Martin:

Please find attached a proposal from Adco Electric in the amount of \$520.00. I have reviewed the proposal and recommend it be accepted.

Please let me know if you have any questions.

Sincerely,

A handwritten signature in blue ink that reads 'David Marsh'.

David Marsh,
President

Accepted by:  JRU
City of Jackson, Mississippi

ADCO ELECTRIC INC.
CONTRACTORS ENGINEERS



2236 MADDOX ROAD P.O. BOX 7396
JACKSON, MISSISSIPPI 39282-7396
(601) 922-3576 FAX (601) 922-9705

PROPOSAL

Date: 4/27/23

To: David Marsh

c/o Benchmark Construction Management

Re: MS Arts Center Elevator Lobby light fixture type D

David,

We are pleased to provide our price to provide and install (1) new type D downlight into the Elevator Lobby area as per the Architect's Drawing for CR103 Drawing.

Our price including Tax for this installed work is: \$ 520

Please advise if we are to proceed with this new work and we will order the lights and equipment as needed.

As time is of the essence on this project; this price will be good for 7 calendar days from date of this proposal.

Respectfully submitted,

Andy Hardin, VP

Adco Electric, Inc.

ADCO ELECTRIC INC.
CONTRACTORS ENGINEERS



Adco Electric Inc.
P.O. Box 7395
Jackson, MS 39282-7395

CCN # 3
Date: 4/4/2023
Project Name: ARTS CENTER OF MISSISSIPPI RENOVATIONE
Project Number: ARTS CENTER OF MISSISSIPPI RENOVATIONE
Page Number: 1

Client Address:

BENCHMARK
Contact: DAVID MARSH
1887 CRANE RIDGE DRIVE
SUITE 200A
JACKSON, MS 39216

Work Description

CCN#03; COP #03 per CCD

We reserve the right to correct this quote for errors and omissions.
This quote covers direct costs only and we reserve the right to claim for impact and consequential costs.
This price is good for acceptance within 2 days from the date of receipt.
We request a time extension of 1 days.

Itemized Breakdown

Description	Qty U	Total Mat.	Labor U	Total Hrs.
D	1E	0.00	0.94E	0.94
1/2" CONDUIT - EMT	25C	14.74	4.50C	1.13
1/2" CONN SS STL - EMT	2C	0.54	8.00C	0.16
1/2" COUPLING SS STL - EMT	3C	0.93	4.00C	0.10
1/2 OR 3/4" SNAP CLOSE CLIP - BTM MN	3C	7.20	5.00C	0.14
#12 THHN SOLID BLACK	28M	5.74	6.00M	0.17
#12 THHN SOLID WHITE	28M	5.74	6.00M	0.17
#12 THHN SOLID GREEN	28M	5.74	6.00M	0.17
#12/2C CABLE MC - ALUM ARMOR	9M	7.68	30.00M	0.28
1/2 MC-AC SNAP-IN CONN	2C	0.88	0.25E	0.50
3/8" CBL SNAP CLOSE CLIP - BTM MNT O	1C	1.74	8.38C	0.11
WIRE CONN RED	3C	0.96	7.50C	0.23
RED/YELLOW SKIRT WIRE NUTS	3C	0.63	7.50C	0.23
4x 1 1/2" SQ BOX COMB KO	1C	4.96	30.00C	0.30
4" SQ BLANK COVER	2C	4.13	8.00C	0.16
#8x 1/2 WAFER HEAD SELF-TAP STUD	4C	0.18	5.00C	0.20
#8x 1/2 WAFER HEAD SHEET MTL SCR	2C	0.18	1.88C	0.04
FIXTURE MOUNTING 10 TO 15' HEIGHT	1E	0.00	0.38E	0.38
4" SQ 2 1/8" DEEP JBOX - 1/2"-3/4" KO	1C	0.91	11.40C	0.11

ORIGINAL

**REGULAR MEETING OF THE CITY COUNCIL
TUESDAY, MAY 9, 2023 10:00 A.M.**

Adco Electric Inc.
P.O. Box 7395
Jackson, MS 39282-7395

Client Address:

BENCHMARK
1867 CRANE RIDGE DRIVE
SUITE 200A
JACKSON, MS 39216

CCN # **3**
Date: **4/4/2023**
Project Name: **ARTS CENTER OF MISSISSIP**
Project Number: **ARTS CENTER OF MISSISSIP**
Page Number: **2**

Description	QtyU	Total Mat.	LaborU	Total Hrs.
Totals	145	62.87		5.47

Summary

General Materials				62.87
FIXTURES				148.50
Material Total				211.37
LABOR				
ELECTRICIAN	(2.74 Hrs @ \$46.50)			127.41
APPRENTICE	(2.74 Hrs @ \$38.10)			104.39
Indirect Job Cost				
CONSUMABLES & MISCELLANEOUS	(62.87 @ 0.00 @ \$0.03 + 0.000 % + 0.000 % + 0.000 %)			1.89
CLEAN-UP	(5.48 @ 0.00 @ \$0.05 + 0.000 % + 0.000 % + 0.000 %)			0.27
SAFETY MEETINGS	(5.48 @ 0.00 @ \$0.01 + 0.000 % + 0.000 % + 0.000 %)			0.05
SMALL TOOLS	(5.48 @ 0.00 @ \$0.45 + 0.000 % + 0.000 % + 0.000 %)			2.47
WARRANTY	(62.87 @ 0.00 @ \$0.03 + 0.000 % + 0.000 % + 0.000 %)			1.89
Total Indirect Job Cost				6.57
Subtotal				448.74
Overhead	(@ 10.000 %)			44.97
Markup	(@ 5.000 %)			24.74
Subtotal				518.45
Final Adjustment				0.55
Final Amount				\$520.00

CONTRACTOR CERTIFICATION

Name:	_____
Date:	_____
Signature:	_____
<small>I hereby certify that this quotation is complete and accurate based on the information provided.</small>	

CLIENT ACCEPTANCE

CCN #: 3	_____
Final Amount: \$520.00	_____
Name:	_____
Date:	_____
Signature:	_____
<small>I hereby accept this quotation and authorize the contractor to complete the above described work.</small>	

ORIGINAL



April 25, 2023

Catoria P. Martin
City Attorney
City of Jackson, MS
Post Office Box 2779
Jackson, MS 39207

Re: Arts Center – Track, Light, Switch

Dear Ms. Martin:

Please find attached a proposal from Adco Electric in the amount of \$1,210.00. I have reviewed the proposal and recommend it be accepted.

Please let me know if you have any questions.

Sincerely,

A handwritten signature in blue ink, appearing to read 'David Marsh'.

David Marsh,
President

Accepted by:  
City of Jackson, Mississippi

ADCO ELECTRIC INC.
CONTRACTORS ENGINEERS



2236 MADDOX ROAD P.O. BOX 7385
JACKSON, MISSISSIPPI 39282-7385
(601) 922-3575 FAX (601) 922-9705

PROPOSAL

Date: 4/27/23

To: David Marsh

c/o Benchmark Construction Management

Re: MS Arts Center Adding new Type H Trac and Dimmer Switch

David,

We are pleased to provide our price to provide and install new type H Trac and Dimmer Switch as per the Architect's Drawing for CR102 Drawing.

Our price including Tax for this installed work is: \$ 1,210

Please advise if we are to proceed with this new work and we will order the lights and equipment as needed.

As time is of the essence on this project; this price will be good for 7 calendar days from date of this proposal.

Respectfully submitted,

Andy Hardin, VP

Adco Electric, Inc.

ADCO ELECTRIC INC.
CONTRACTORS ENGINEERS



Adco Electric Inc.
P.O. Box 7395
Jackson, MS 39282-7395

CCN # 2
Date: 4/4/2023
Project Name: ARTS CENTER OF MISSISSIPPI RENOVATIONS
Project Number: ARTS CENTER OF MISSISSIPPI RENOVATIONS
Page Number: 1

Client Address:

BENCHMARK
Contact: DAVID MARSH
1867 CRANE RIDGE DRIVE
SUITE 200A
JACKSON, MS 39216

Work Description

CCN#02: COP #02 per CCD

We reserve the right to correct this quote for errors and omissions.
This quote covers direct costs only and we reserve the right to claim for impact and consequential costs.
This price is good for acceptance within 2 days from the date of receipt.
We request a time extension of 1 days.

Itemized Breakdown

Description	Qty U	Total Mat.	Labor U	Total Hrs.
H track 8ft length	1 E	0.00	1.96 E	1.96
1/2" CONDUIT - EMT	45 C	28.48	4.50 C	2.02
1/2" CONN SS STL - EMT	4 C	1.08	8.00 C	0.32
1/2" COUPLING SS STL - EMT	5 C	1.67	4.00 C	0.18
1/2 OR 3/4" SNAP CLOSE CLIP - BTM MN	5 C	12.94	5.00 C	0.24
1/2" FLEX - STEEL	14 C	15.29	4.00 C	0.56
1/2" STL FLEX CONN	4 C	10.49	12.00 C	0.48
#12 THHN BLACK	24 M	6.87	6.00 M	0.14
#12 THHN SOLID BLACK	83 M	17.21	6.00 M	0.50
#12 THHN SOLID WHITE	50 M	10.33	6.00 M	0.30
#12 THHN SOLID GREEN	50 M	10.33	6.00 M	0.30
WIRE CONN RED	9 C	2.63	7.50 C	0.68
DEV BOX 2 1/2" DEEP 1/2" KO W/ EARS	1 C	7.04	25.00 C	0.25
4x 1 1/2" OCT BOX 1/2" KO	1 C	4.85	30.00 C	0.30
4x 1 1/2" SQ BOX COMB KO	2 C	9.92	30.00 C	0.60
4" SQ BLANK COVER	2 C	4.13	8.00 C	0.16
1 x 1 5/8x 12G STRUT GRN	8 C	49.38	10.00 C	0.80
#8 TO #10x 7/8 PLAS ANCHOR (3/16)	2 C	8.88	15.00 C	0.30
1/4" THREADED ROD - PLTD	16 C	9.88	11.00 C	1.76

ORIGINAL

**REGULAR MEETING OF THE CITY COUNCIL
TUESDAY, MAY 9, 2023 10:00 A.M.**

Adco Electric Inc.
P.O. Box 7395
Jackson, MS 39282-7395

Client Address:

BENCHMARK
1867 CRANE RIDGE DRIVE
SUITE 200A
JACKSON, MS 39216

CCN # **2**
Date: **4/4/2023**
Project Name: **ARTS CENTER OF MISSISSIP**
Project Number: **ARTS CENTER OF MISSISSIP**
Page Number: **2**

Description	Qty U	Total Mat.	Labor U	Total Hrs.
1/4-20 HEX NUT - PLTD STL	8 C	0.56	2.40 C	0.19
1/4" FLAT WASHER - PLTD STL	12 C	0.99	1.25 C	0.15
1/4x4 TGL BOLT SPRING WING P/H	4 C	1.80	12.00 C	0.48
#10x1 P/H SELF-TAP SCREW	2 C	0.20	5.50 C	0.11
#8x 1/2 WAFER HEAD SHEET MTL SCR	4 C	0.37	1.88 C	0.08
OLD WORK BOX MOUNT F-CLIPS (PR)	1 C	0.87	10.00 C	0.10
512 24" T-BAR BOX HNGR (CADDY)	1 C	12.05	18.75 C	0.19
4G9 T-BAR TWIST-ON FIXT SUPPORT (2 C	4.29	9.38 C	0.19
1G TGL SWITCH PLATE - 302 S/S	1 C	1.49	10.00 C	0.10
20A 120-277V S/P SW - TOGGLE IVY (CS-	1 C	4.77	25.00 C	0.25
TRACK LIVE END CONN FLUSH	1 E	0.00	0.25 E	0.25
DEMO SWITCH	1 E	0.00	0.19 E	0.19
Totals	382	238.59		14.12

Summary

General Materials		238.59
FIXTURES		190.00
Material Total		428.59
LABOR		
ELECTRICIAN	(7.06 Hrs @ \$46.50)	328.29
APPRENTICE	(7.06 Hrs @ \$38.10)	268.99
Indirect Job Cost		
CONSUMABLES & MISCELLANEOUS	(238.59 @ 0.00 @ \$0.03 + 0.000 % + 0.000 % + 0.000 %)	7.16
CLEAN-UP	(14.12 @ 0.00 @ \$0.05 + 0.000 % + 0.000 % + 0.000 %)	0.71
SAFETY MEETINGS	(14.12 @ 0.00 @ \$0.01 + 0.000 % + 0.000 % + 0.000 %)	0.14
SMALL TOOLS	(14.12 @ 0.00 @ \$0.45 + 0.000 % + 0.000 % + 0.000 %)	6.35
WARRANTY	(238.59 @ 0.00 @ \$0.03 + 0.000 % + 0.000 % + 0.000 %)	7.16
Total Indirect Job Cost		21.52
Subtotal		1,047.39
Overhead	(@ 10.000 %)	104.74
Markup	(@ 5.000 %)	57.61
Subtotal		1,209.74
Final Adjustment		0.26
Final Amount		\$1,210.00

CONTRACTOR CERTIFICATION

Name:	_____
Date:	_____
Signature:	_____
I hereby certify that this quotation is complete and accurate based on the information provided	

CLIENT ACCEPTANCE

ORIGINAL

REGULAR MEETING OF THE CITY COUNCIL
TUESDAY, MAY 9, 2023 10:00 A.M.

Adco Electric Inc.
P.O. Box 7395
Jackson, MS 39282-7395

Client Address:
BENCHMARK
1867 CRANE RIDGE DRIVE
SUITE 200A
JACKSON, MS 39216

CCN # 2
Date: 4/4/2023
Project Name: ARTS CENTER OF MISSISSIP
Project Number: ARTS CENTER OF MISSISSIP
Page Number: 3

CCN #: 2	_____
Final Amount:\$1,210.00	_____
Name:	_____
Date:	_____
Signature:	_____
<small>I hereby accept this quotation and authorize the contractor to complete the above described work.</small>	

ORIGINAL



April 27, 2023

Catoria P. Martin
City Attorney
City of Jackson, MS
Post Office Box 2779
Jackson, MS 39207

Re: Thalia Mara – General Cleaning, Wash Interior & Exterior Windows

Dear Ms. Martin:

Please find attached a proposal from Jani King in the amount of \$8,370.00. I have reviewed the proposal and recommend it be accepted.

Please let me know if you have any questions.

Sincerely,

A handwritten signature in blue ink, appearing to read 'David Marsh', written over a horizontal line.

David Marsh,
President

Accepted by:

A handwritten signature in blue ink, written over a horizontal line. The signature is stylized and difficult to decipher.

City of Jackson, Mississippi



ONE TIME SERVICE AGREEMENT

(Form not intended for current customers)

DATE OF SERVICE		NAME OF COMPANY AGREEING TO SERVICES City of Jackson	
NAME OF LOCATION SERVICED Thalia Mara Hall		NAME OF COMPANY REPRESENTATIVE Benchmark Construction / David Marsh	
ADDRESS WHERE SERVICE PROVIDED 255 E Pascagoula Street		PHONE NUMBER OF COMPANY REPRESENTATIVE (601) 941-7250	
CITY, STATE, ZIP WHERE SERVICE PROVIDED Jackson, MS, 39201		EMAIL ADDRESS OF COMPANY REPRESENTATIVE dmarsh@benchmarkms.com	
HAVE WE SERVICED UNDER A ONE TIME AGREEMENT BEFORE? <input type="checkbox"/> YES <input checked="" type="checkbox"/> NO IF YES, CUST# _____		JANI-KING REP Rashad Randle	SERVICED BY (FIRAN NAME and #) Allstar Solutions, LLC 041158
ACCOUNTS PAYABLE INFORMATION (MUST BE COMPLETED)		JOB INFORMATION (MUST BE COMPLETED)	
NAME OF A/P CONTACT		PURCHASE ORDER/JOB NUMBER	
ADDRESS OF A/P DEPARTMENT		INSURANCE CERTIFICATE NEEDED? <input type="checkbox"/> YES <input checked="" type="checkbox"/> NO IF YES, Attach copy	
CITY, STATE, ZIP OF A/P DEPARTMENT		SPECIAL INSURANCE REQUIRED? <input type="checkbox"/> YES <input checked="" type="checkbox"/> NO IF YES, Attach copy	
A/P PHONE NUMBER		WAIVER OF LIEN REQUIRED? <input type="checkbox"/> YES <input checked="" type="checkbox"/> NO IF YES, Attach copy	
A/P ALTERNATE NUMBER		Client agrees that the above mentioned items, documentation, insurance, etc. are either required or not as indicated above.	
A/P EMAIL ADDRESS			
AUTHORIZED SIGNATURE			
SERVICES REQUESTED			
1. General cleaning			
2. Thoroughly wash interior and exterior of windows			
3.			

TOTAL COST: \$ 8,370.00

Sales tax not included - applicable to FL and TX only.
Credit Card Payments are subject to a 3% fee.

This Agreement supersedes all prior Agreements. JANI-KING WILL NOT BE LIABLE FOR CONDITIONS BEYOND OUR CONTROL, INCLUDING THOSE CONDITIONS THAT EXIST PRIOR TO CLEANING OR WHICH PRESENT AFTER CLEANING. Customer should be careful in the event the cleaning service specifications include floor care services, as floors may be slippery due to damp conditions. Client consents to the use of EPA approved chemicals selected by JANI-KING for cleaning COVID-19. To the extent client wishes to direct which specific chemicals are used, Client will notify JANI-KING in writing.

~~INDEMNITY: Client agrees to defend, indemnify, and hold harmless Jani-King, and their respective affiliates, franchisees, officers, directors, shareholders, members, employees, agents and representatives, from all claims, demands, liabilities, injuries, damages, losses, and expenses arising out of or related to the presence, or suspected presence, of any infectious pathogens at Client's facility (including, without limitation, SARS-CoV-2/COVID-19) and any exposure to such pathogens from Client's facility.~~

Payment of the Total Amount shall be due from Client within ⁴⁵ ~~thirty~~ (30) days of completion of the work. In the event the full Total Amount is not paid within ~~thirty~~ ⁴⁵ days, interest shall accrue on any remaining balance at a rate of 12% per day. In the event it becomes necessary for Jani-King to institute suit against Client to secure or protect its rights or to collect any sums due under this Agreement, Jani-King shall be entitled to all associated costs of the suit, including reasonable attorney's fees and interest. The terms of this Agreement shall be binding upon and inure to the benefit of Jani-King and Client and their respective heirs, representatives, successors and assigns, except as otherwise herein provided. Any waiver by either party to this Agreement of a breach of any term or condition of this Agreement shall not constitute a waiver of any subsequent breach of the same or any other term or condition of this Agreement. Jurisdiction and venue for any suit brought on this Agreement shall be in the county or parishes where the Jani-King regional office is located. **HINDS COUNTY, MS**

AUTHORIZATION FOR WORK TO BEGIN AND GUARANTY

The undersigned individual owner, officer, agent, member or employee of Client hereby guarantees the payment to Jani-King of the total amount indicated above. Said individual acknowledges that without this guaranty of payment, Jani-King would not enter into this Agreement.

_____ AUTHORIZED SIGNATURE	_____ PRINTED NAME & TITLE	_____ DATE
-------------------------------	-------------------------------	---------------

COMPLETED WORK

All work described has been inspected and completed to my satisfaction. Payment for these services is authorized upon receipt of Jani-King Invoice.

_____ AUTHORIZED SIGNATURE	_____ PRINTED NAME & TITLE	_____ DATE
-------------------------------	-------------------------------	---------------

NOT AN INVOICE



April 27, 2023

Catoria P. Martin
City Attorney
City of Jackson, MS
Post Office Box 2779
Jackson, MS 39207

Re: Thalia Mara – Scrub Ceramic Tile

Dear Ms. Martin:

Please find attached a proposal from Jani King in the amount of \$990.00. I have reviewed the proposal and recommend it be accepted.

Please let me know if you have any questions.

Sincerely,

A handwritten signature in blue ink, appearing to read 'David Marsh'.

David Marsh,
President

Accepted by:

A handwritten signature in blue ink, likely representing the City of Jackson, positioned above a horizontal line.
City of Jackson, Mississippi



ONE TIME SERVICE AGREEMENT

(Form not intended for current customers)

DATE OF SERVICE		NAME OF COMPANY AGREEING TO SERVICES City of Jackson	
NAME OF LOCATION SERVICED Thalia Mara Hall		NAME OF COMPANY REPRESENTATIVE Benchmark Construction / David Marsh	
ADDRESS WHERE SERVICE PROVIDED 255 E Pascagoula Street		PHONE NUMBER OF COMPANY REPRESENTATIVE (601) 941-7250	
CITY, STATE, ZIP WHERE SERVICE PROVIDED Jackson, MS, 39201		EMAIL ADDRESS OF COMPANY REPRESENTATIVE dmarsh@benchmarkms.com	
HAVE WE SERVICED UNDER A ONE TIME AGREEMENT BEFORE? <input type="checkbox"/> YES <input checked="" type="checkbox"/> NO IF YES, CUST# _____		JANI-KING REP Rashad Randle	SERVICED BY (FRAN NAME and#) Alistar Solutions, LLC 041158
ACCOUNTS PAYABLE INFORMATION (MUST BE COMPLETED)		JOB INFORMATION (MUST BE COMPLETED)	
NAME OF A/P CONTACT		PURCHASE ORDER/JOB NUMBER	
ADDRESS OF A/P DEPARTMENT		INSURANCE CERTIFICATE NEEDED? <input type="checkbox"/> YES <input checked="" type="checkbox"/> NO IF YES, Attach copy	
CITY, STATE, ZIP OF A/P DEPARTMENT		SPECIAL INSURANCE REQUIRED? <input type="checkbox"/> YES <input checked="" type="checkbox"/> NO IF YES, Attach copy	
A/P PHONE NUMBER		WAIVER OF LIEN REQUIRED? <input type="checkbox"/> YES <input checked="" type="checkbox"/> NO IF YES, Attach copy	
A/P ALTERNATE NUMBER		Client agrees that the above mentioned items, documentation, insurance, etc. are either required or not as indicated above.	
A/P EMAIL ADDRESS			
AUTHORIZED SIGNATURE			
SERVICES REQUESTED			
1. Scrub of ceramic tile			
2.			
3.			

TOTAL COST: \$ 990.00

Sales tax not included - applicable to FL and TX only.
Credit Card Payments are subject to a 3% fee.

This Agreement supersedes all prior Agreements. JANI-KING WILL NOT BE LIABLE FOR CONDITIONS BEYOND OUR CONTROL, INCLUDING THOSE CONDITIONS THAT EXIST PRIOR TO CLEANING OR WHICH PRESENT AFTER CLEANING. Customer should be careful in the event the cleaning service specifications include floor care services, as floors may be slippery due to damp conditions. Client consents to the use of EPA approved chemicals selected by JANI-KING for cleaning COVID-19. To the extent client wishes to direct which specific chemicals are used, Client will notify JANI-KING in writing.

~~JANIKING Client agrees to defend, indemnify and hold harmless Jani-King and their respective officers, franchisees, affiliates, directors, shareholders, members, employees, agents and representatives, from all claims, demands, actions, suits, damages, losses and expenses arising out of or related to the presence, or suspected presence, of any biohazard pathogen at Client's facility including, without limitation, SARS-CoV-2 (COVID-19) and any exposures to such pathogens from Client's facility.~~

Payment of the Total Amount shall be due from Client within (10) ⁴⁵ days of completion of the work. In the event the full Total Amount is not paid within ~~30~~ ⁴⁵ days, interest shall accrue on any remaining balance of ~~total amount~~ ^{total amount} in the event it becomes necessary for Jani-King to institute suit against Client to secure or protect its rights or to collect any sums due under this Agreement, Jani-King shall be entitled to all associated costs of the suit, including reasonable attorney's fees and interest. The terms of this Agreement shall be binding upon and inure to the benefit of Jani-King and Client and their respective heirs, representatives, successors and assigns, except as otherwise herein provided. Any waiver by either party to this Agreement of a breach of any term or condition of this Agreement shall not constitute a waiver of any subsequent breach of the same or any other term or condition of this Agreement. Jurisdiction and venue for any suit brought on this Agreement shall be in the county or parish where the Jani-King regional office is located - **HINDS COUNTY, MS**

AUTHORIZATION FOR WORK TO BEGIN AND GUARANTY

The undersigned individual owner, officer, agent, member or employee of Client hereby guarantees the payment to Jani-King of the total amount indicated above. Said individual acknowledges that without this guaranty of payment, Jani-King would not enter into this Agreement.

AUTHORIZED SIGNATURE _____ PRINTED NAME & TITLE _____ DATE _____

COMPLETED WORK

All work described has been inspected and completed to my satisfaction. Payment for these services is authorized upon receipt of Jani-King Invoice.

AUTHORIZED SIGNATURE _____ PRINTED NAME & TITLE _____ DATE _____

NOT AN INVOICE



April 27, 2023

Catoria P. Martin
City Attorney
City of Jackson, MS
Post Office Box 2779
Jackson, MS 39207

Re: Thalia Mara – Carpet Extraction

Dear Ms. Martin:

Please find attached a proposal from Jani King in the amount of \$2,304.00. I have reviewed the proposal and recommend it be accepted.

Please let me know if you have any questions.

Sincerely,

A handwritten signature in blue ink, appearing to read 'David Marsh'.

David Marsh,
President

Accepted by: _____

A handwritten signature in blue ink, appearing to be a name followed by 'Jr.'.
City of Jackson, Mississippi



ONE TIME SERVICE AGREEMENT

(Form not intended for current customers)

DATE OF SERVICE	NAME OF COMPANY AGREEING TO SERVICES City of Jackson	
NAME OF LOCATION SERVICED Thalla Mara Hall	NAME OF COMPANY REPRESENTATIVE Benchmark Construction / David Marsh	
ADDRESS WHERE SERVICE PROVIDED 255 E Pascagoula Street	PHONE NUMBER OF COMPANY REPRESENTATIVE (801) 941-7250	
CITY, STATE, ZIP WHERE SERVICE PROVIDED Jackson, MS, 39201	EMAIL ADDRESS OF COMPANY REPRESENTATIVE dmarsh@benchmarkms.com	
HAVE WE SERVICED UNDER A ONE TIME AGREEMENT BEFORE? <input type="checkbox"/> YES <input checked="" type="checkbox"/> NO IF YES, CUST# _____	JANI-KING REP Rashad Randle	SERVICED BY (FRAN NAME and #) Allstar Solutions, LLC 041158

ACCOUNTS PAYABLE INFORMATION (MUST BE COMPLETED)	JOB INFORMATION (MUST BE COMPLETED)
NAME OF A/P CONTACT	PURCHASE ORDER/JOB NUMBER
ADDRESS OF A/P DEPARTMENT	INSURANCE CERTIFICATE NEEDED? <input type="checkbox"/> YES <input checked="" type="checkbox"/> NO IF YES, Attach copy
CITY, STATE, ZIP OF A/P DEPARTMENT	SPECIAL INSURANCE REQUIRED? <input type="checkbox"/> YES <input checked="" type="checkbox"/> NO IF YES, Attach copy
A/P PHONE NUMBER	WAIVER OF LIEN REQUIRED? <input type="checkbox"/> YES <input checked="" type="checkbox"/> NO IF YES, Attach copy
A/P ALTERNATE NUMBER	Client agrees that the above mentioned items, documentation, insurance, etc. are either required or not as indicated above. _____ AUTHORIZED SIGNATURE
A/P EMAIL ADDRESS	

SERVICES REQUESTED

1. Carpet extraction
- 2.
- 3.

TOTAL COST: \$ 2,304.00

Sales tax not included - applicable to FL and TX only.
Credit Card Payments are subject to a 3% fee.

This Agreement supersedes all prior Agreements. JANI-KING WILL NOT BE LIABLE FOR CONDITIONS BEYOND OUR CONTROL, INCLUDING THOSE CONDITIONS THAT EXIST PRIOR TO CLEANING OR WHICH PRESENT AFTER CLEANING. Customer should be careful in the event the cleaning service specifications include floor care services, as floors may be slippery due to damp conditions. Client consents to the use of EPA approved chemicals selected by JANI-KING for cleaning COVID-19. To the extent client wishes to direct which specific chemicals are used, Client will notify JANI-KING in writing.

~~JANI-KING Client agrees to defend, indemnify, and hold harmless Jani-King, and their respective affiliates, franchisees, officers, directors, shareholders, members, employees, agents, and representatives, from all claims, demands, damages, losses, and expenses, arising out of or related to the presence, or suspected presence, of any infectious pathogens at Client's facility (including, without limitation, SARS-CoV-2, COVID-19) and any exposure to such pathogens from Client's facility.~~

Payment of the Total Amount shall be due from Client within ~~thirty (30) days~~ ⁴⁵ days of completion of the work. In the event the full Total Amount is not paid within ~~thirty (30) days~~ ⁴⁵ days, interest shall accrue on any remaining balance at a rate of 4.5% per day. In the event it becomes necessary for Jani-King to institute suit against Client to secure or protect its rights or to collect any sums due under this Agreement, Jani-King shall be entitled to all associated costs of the suit, including reasonable attorney fees and interest. The terms of this Agreement shall be binding upon and inure to the benefit of Jani-King and Client and their respective heirs, representatives, successors and assigns, except as otherwise herein provided. Any waiver by either party to this Agreement of a breach of any term or condition of this Agreement shall not constitute a waiver of any subsequent breach of the same or any other term or condition of this Agreement. Jurisdiction and venue for any suit brought on this Agreement shall be in ~~the county or parish where the Jani-King regional office is located~~ ^{HINDS COUNTY, MS}

AUTHORIZATION FOR WORK TO BEGIN AND GUARANTY

The undersigned individual owner, officer, agent, member or employee of Client hereby guarantees the payment to Jani-King of the total amount indicated above. Said individual acknowledges that without this guaranty of payment, Jani-King would not enter into this Agreement.

_____ AUTHORIZED SIGNATURE	_____ PRINTED NAME & TITLE	_____ DATE
COMPLETED WORK		
All work described has been inspected and completed to my satisfaction. Payment for these services is authorized upon receipt of Jani-King invoice.		
_____ AUTHORIZED SIGNATURE	_____ PRINTED NAME & TITLE	_____ DATE

NOT AN INVOICE



April 27, 2023

Catoria P. Martin
City Attorney
City of Jackson, MS
Post Office Box 2779
Jackson, MS 39207

Re: Arts Center – General Cleaning, Wash Interior & Exterior Windows

Dear Ms. Martin:

Please find attached a proposal from Jani King in the amount of \$500.00. I have reviewed the proposal and recommend it be accepted.

Please let me know if you have any questions.

Sincerely,

A handwritten signature in blue ink, appearing to read 'David Marsh'.

David Marsh,
President

Accepted by:

A handwritten signature in blue ink, appearing to be a name followed by 'psw'. Below the signature is a horizontal line.

City of Jackson, Mississippi



ONE TIME SERVICE AGREEMENT

(Form not intended for current customers)

DATE OF SERVICE	NAME OF COMPANY AGREEING TO SERVICES City of Jackson	
NAME OF LOCATION SERVICED Arts Center	NAME OF COMPANY REPRESENTATIVE Benchmark Construction / David Marsh	
ADDRESS WHERE SERVICE PROVIDED 255 E Pascagoula Street	PHONE NUMBER OF COMPANY REPRESENTATIVE (601) 941-7250	
CITY, STATE, ZIP WHERE SERVICE PROVIDED Jackson, MS, 39201	EMAIL ADDRESS OF COMPANY REPRESENTATIVE dmarsh@benchmarkms.com	
HAVE WE SERVICED UNDER A ONE TIME AGREEMENT BEFORE? <input type="checkbox"/> YES <input checked="" type="checkbox"/> NO IF YES, CUST# _____	JAN-KING REP Rashad Randle	SERVICED BY (FIRM NAME and #) Allstar Solutions, LLC 041158
ACCOUNTS PAYABLE INFORMATION (MUST BE COMPLETED)		JOB INFORMATION (MUST BE COMPLETED)
NAME OF A/P CONTACT		PURCHASE ORDER/JOB NUMBER
ADDRESS OF A/P DEPARTMENT		INSURANCE CERTIFICATE NEEDED? <input type="checkbox"/> YES <input checked="" type="checkbox"/> NO IF YES, Attach copy
CITY, STATE, ZIP OF A/P DEPARTMENT		SPECIAL INSURANCE REQUIRED? <input type="checkbox"/> YES <input checked="" type="checkbox"/> NO IF YES, Attach copy
A/P PHONE NUMBER		WAIVER OF LIEN REQUIRED? <input type="checkbox"/> YES <input checked="" type="checkbox"/> NO IF YES, Attach copy
A/P ALTERNATE NUMBER		Client agrees that the above mentioned items, documentation, insurance, etc. are either required or not as indicated above.
A/P EMAIL ADDRESS		
AUTHORIZED SIGNATURE		
SERVICES REQUESTED		
1. General cleaning		
2. Thoroughly wash interior and exterior of windows		
3.		

TOTAL COST: \$ 500.00

Sales tax not included - applicable to FL and TX only.
Credit Card Payments are subject to a 3% fee.

This Agreement supersedes all prior Agreements. JAN-KING WILL NOT BE LIABLE FOR CONDITIONS BEYOND OUR CONTROL, INCLUDING THOSE CONDITIONS THAT EXIST PRIOR TO CLEANING OR WHICH PRESENT AFTER CLEANING. Customer should be careful in the event the cleaning service specifications include floor care services, as floors may be slippery due to damp conditions. Client consents to the use of EPA approved chemicals selected by JAN-KING for cleaning COVID-19. To the extent client wishes to direct which specific chemicals are used, Client will notify JAN-KING in writing.

~~INDEMNITY: Client agrees to defend, indemnify, and hold Jan-King and their respective officers, directors, employees, members, employees, agents, and representatives, from all claims, demands, liabilities, injuries, damages, losses, and expenses arising out of or related to the presence, or suspected presence, of any bacteria, pathogens, or chemicals (including, without limitation, COVID-19) and any exposure to such pathogens from Client's facility.~~

Payment of the Total Amount shall be due from Client within fifteen (15) days of completion of the work. In the event the full Total Amount is not paid within ~~thirty (30)~~ ⁴⁵ days, interest shall ~~accrue on any remaining balance at a rate of 1.5% per day.~~ In the event it becomes necessary for Jan-King to institute suit against Client to secure or protect its rights or to collect any sums due under this Agreement, Jan-King shall be entitled to all reasonable costs of the suit, including reasonable attorney's fees and interest. The terms of this Agreement shall be binding upon and inure to the benefit of Jan-King and Client and their respective heirs, representatives, successors and assigns, except as otherwise herein provided. Any waiver by either party to this Agreement of a breach of any term or condition of this Agreement shall not constitute a waiver of any subsequent breach of the same or any other term or condition of this Agreement. Jurisdiction and venue for any suit brought on this Agreement shall be in the county or parish where the Jan-King regional office is located.

AUTHORIZATION FOR WORK TO BEGIN AND GUARANTY

Hinds County, MS

The undersigned individual owner, officer, agent, member or employee of Client hereby guarantees the payment to Jan-King of the total amount indicated above. Said individual acknowledges that without this guaranty of payment, Jan-King would not enter into this Agreement.

AUTHORIZED SIGNATURE _____ PRINTED NAME & TITLE _____ DATE _____

COMPLETED WORK

All work described has been inspected and completed to my satisfaction. Payment for these services is authorized upon receipt of Jan-King invoice.

AUTHORIZED SIGNATURE _____ PRINTED NAME & TITLE _____ DATE _____

NOT AN INVOICE



May 1, 2023

Catoria P. Martin
City Attorney
City of Jackson, MS
Post Office Box 2779
Jackson, MS 39207

Re: Thalia Mara – Investigate Leak

Dear Ms. Martin:

Please find attached a proposal from Guaranteed Roofing in the amount of \$1,250.00. I have reviewed the proposal and recommend it be accepted.

Please let me know if you have any questions.

Sincerely,

A handwritten signature in blue ink, appearing to read 'D Marsh'.

David Marsh,
President

Accepted by:

A handwritten signature in blue ink, with the initials 'Jaw' written above it. The signature is written over a horizontal line.

City of Jackson, Mississippi



PROPOSAL

May 1, 2023

- | | |
|---|------------|
| 1. Investigate leak at Thalia Mara Hall | \$1,250.00 |
|---|------------|

Thank you,
Shelley R Joiner
Shelley R Joiner
Vice President

601-939-2846
rene@guaranteedroofingcompany.com
www.greateroofers.com
P.O. Box 54122
Pearl, MS 39288-4122

Vice President Lee moved adoption; **Council Member Lindsay** seconded.

Yeas – Banks, Foote, Grizzell, Hartley, Lee and Lindsay.

Nays – None.

Absent – Stokes.

Note: Council Member Grizzell left the meeting.

DISCUSSION: CITY GRANT PROGRAMS: **President Foote** recognized **Council Member Hartley** who requested an update on the status of the city’s grants management program. **President Foote** recognized **Dr. Safiya Omari, Chief of Staff**, who stated that the Administration is in the process of interviewing for positions within the Grants Management Division.

Note: Vice President Lee left the meeting.

DISCUSSION: TRAFFIC LIGHTS: President Foote stated said item would be pulled at the request of Vice President Lee.

There came on for Discussion, Agenda Item No. 37:

DISCUSSION: LITIGATION: President Foote stated said discussion would be held in Executive Session.

There came on for Discussion, Agenda Item No. 38:

DISCUSSION: Personnel: said item was pulled by President Foote.

The following reports/announcements were provided during the meeting:

- **Council Member Lindsay, Council Member Banks and Council Member Hartley** announced the following:
 - Encourage citizens to remember **Council Member Stokes** and his family during the loss of his wife **Judge LaRita Cooper-Stokes**.

MONTHLY REPORT OF PRIVILEGE TAXES AS REQUIRED ACCORDING TO SECTION 27-17-501 OF THE MISSISSIPPI CODE ANNOTATED OF 1972. President Foote stated that all City Council members had received the monthly privilege taxes report for review.

President Foote recognized **Council Member Hartley** who moved, seconded by **Council Member Lindsay** to go into Closed Session to take up Agenda Items 8,7, and 20. The motion prevailed by the following vote:

Yeas – Banks, Foote, Hartley and Lindsay.
Nays – None.
Absent – Grizzell, Lee and Stokes.

President Foote announced to the public that the Council voted to go into Closed Session to discuss going into Executive Session regarding “Litigation”.

During Closed Session, **Council Member Lindsay** moved, seconded by **Council Member Banks** to go into Executive Session regarding “Litigation”.

Yeas – Banks, Foote, Hartley and Lindsay.
Nays – None.
Absent – Grizzell, Lee and Stokes.

President Foote recognized **Council Member Hartley** who moved, seconded by **Council Member Lindsay**, to come out of Executive Session. The motion prevailed by the following vote:

Yeas – Banks, Foote, Hartley and Lindsay.
Nays – None.

**REGULAR MEETING OF THE CITY COUNCIL
TUESDAY, MAY 9, 2023 10:00 A.M.**

Absent – Grizzell, Lee and Stokes.

President Foote announced to the public that the Council voted to come out of Executive Session and no action was taken.

There being no further business to come before the City Council, it was unanimously voted to adjourn until the Regular Zoning Council Meeting at 2:30 p.m. on May 15, 2023. At 12:52 p.m., the Council stood adjourned.

PREPARED BY:

APPROVED:

CLERK OF COUNCIL

_____, _____
COUNCIL PRESIDENT DATE

MAYOR

ATTEST:

CITY CLERK

#7

BE IT REMEMBERED that a Regular Zoning Meeting of the City Council of Jackson, Mississippi was convened in the Council Chambers in City Hall at 2:30 p.m. on May 15, 2023, being the third Monday of said month when and where the following things were had and done to wit:

Present: Council Members: Ashby Foote, Council President, Ward 1; Angelique Lee, Council Vice President, Ward 2 (via teleconference); Brian Grizzell, Ward 4 (via teleconference); Aaron Banks, Ward 6 and Virgi Lindsay, Ward 7. Directors: Shanekia Mosley-Jordan, Clerk of Council (via teleconference); Sabrina Shelby, Chief Deputy Clerk of Council; Ester Ainsworth, Zoning Administrator and Kristie Metcalfe, Deputy City Attorney.

Absent: Kenneth I. Stokes, Ward 3 and Vernon Hartley, Ward 5.

* * * * *

The meeting was called to order by **President Ashby Foote**.

* * * * *

President Foote recognized Zoning Administrator **Ester Ainsworth** who provided the Council with a procedural history of Zoning Case No. 4190, including all applicable ordinances, statutes, and a brief review of documents included in the Council agenda packets which were the applicable zoning map, future land use map, photos of the subject area, staff report, application with exhibits and planning board meeting minutes.

President Foote requested that the Clerk read the Order:

ORDINANCE GRANTING JENNIFER WELCH DBA VESICA REAL ESTATE A REZONING OF THE PROPERTIES LOCATED AT 804, 814, 818 & 823 N. JEFFERSON ST. (PARCELS #22-19, 22-18, 22-17, 23-16), 920, 924, 927, 928, 935, 937 HARDING ST. (PARCELS #22-20, 22-21, 25-4, 22-22, 25-7, 25-8) FROM R-1 (SINGLE-FAMILY) RESIDENTIAL DISTRICT TO NMU-1 (NEIGHBORHOOD) MIXED-USE DISTRICT, PEDESTRIAN ORIENTED TO ALLOW FOR CONSISTENCY WITH THE ZONING IN THE IMMEDIATE VICINITY OF THE PROPERTIES AND FOR A COMPATIBLE DIVERSITY OF LAND USES AND AN ORDER GRANTING A USE PERMIT FOR THE PROPERTY LOCATED AT PARCEL 22-19 ON JEFFERSON ST. TO ALLOW FOR ACCESSORY PARKING.

WHEREAS, Jennifer Welch DBA Vesica Real Estate has filed a petition to rezone the properties located at 804, 814, 818 & 823 N. Jefferson St. (Parcels #22-19, 22-18, 22-17, 23-16), 920, 924, 927, 928, 935, 937 Harding St. (Parcels #22-20, 22-21, 25-4, 22-22, 25-7, 25-8) and Parcels 25-7-1 & 25-49 Harding St. from R-1 (Single-Family) Residential District to NMU-1 (Neighborhood) Mixed-Use District, Pedestrian Oriented to allow for consistency with the zoning in the immediate vicinity of the properties and for a compatible diversity of land uses and a Use Permit for Parcel 22-19 to allow for accessory parking in the City of Jackson, First Judicial District of Hinds County, Mississippi; and

WHEREAS, the Jackson City Planning Board, after holding the required public hearing, has offered the recommendation to rezone the properties located at 804, 814, 818 & 823 N. Jefferson St. (Parcels #22-19, 22-18, 22-17, 23-16), 920, 924, 927, 928, 935, 937 Harding St. (Parcels #22-20, 22-21, 25-4, 22-22, 25-7, 25-8) and Parcels 25-7-1 & 25-49 Harding St. from R-1 (Single-Family) Residential District to NMU-1 (Neighborhood) Mixed-Use District, Pedestrian Oriented to allow for consistency with the zoning in the immediate vicinity of the properties and for a compatible diversity of land uses and a Use Permit be granted for Parcel 22-19 to allow for accessory parking; and

WHEREAS, notice was duly and legally given to property owners and interested citizens that a meeting of the Council would be held at the Jackson City Hall at 2:30 p.m.,

Monday, May 15, 2023 to consider said change, based upon the record of the case as developed before the Jackson City Planning Board; and

WHEREAS, it appeared to the satisfaction of the Jackson City Council that notice of said petition had been published in the Mississippi Link on April 6, 2023 and April 20, 2023 that a hearing had been held by the Jackson City Planning Board on April 26, 2023, all as provided for by ordinances of the City of Jackson and the laws of the State of Mississippi, and that the Jackson City Planning Board has offered the recommendation to rezone the properties located at 804, 814, 818 & 823 N. Jefferson St. (Parcels #22-19, 22-18, 22-17, 23-16), 920, 924, 927, 928, 935, 937 Harding St. (Parcels #22-20, 22-21, 25-4, 22-22, 25-7, 25-8) and Parcels 25-7-1 & 25-49 Harding St. from R-1 (Single-Family) Residential District to NMU-1 (Neighborhood) Mixed-Use District, Pedestrian Oriented to allow for consistency with the zoning in the immediate vicinity of the properties and for a compatible diversity of land uses and a Use Permit be granted for Parcel 22-19 to allow for accessory parking; and

WHEREAS, the Jackson City Council after having considered the matter, is of the opinion that such changes would be in keeping with sound land use practice and to the best interest of the City and that there has been a substantial change in the land use character of the surrounding area that justifies rezoning and there is a public need for additional property in that area zoned in accordance with the request in said application since any previous Jackson City Council action for the properties at 804, 814, 818 & 823 N. Jefferson St. (Parcels #22-19, 22-18, 22-17, 23-16), 920, 924, 927, 928, 935, 937 Harding St. (Parcels #22-20, 22-21, 25-4, 22-22, 25-7, 25-8) and Parcels 25-7-1 & 25-49 Harding St.; and

WHEREAS, the Jackson City Council, after having considered the matter, is of the opinion that such changes would be in keeping with sound land use practice and to the best interest of the City and that the proposed use would not be detrimental to the continued use, value, or development of properties in the vicinity and that a Use Permit be granted to allow for an accessory parking lot within the NMU-1 (Neighborhood) Mixed-Use District, Pedestrian Oriented of the City of Jackson for the property located at Parcel 22-19.

NOW, THEREFORE, BE IT ORDAINED BY THE COUNCIL OF THE CITY OF JACKSON, MISSISSIPPI:

Section 1. That the property located in the City of Jackson, First Judicial District of Hinds County, Mississippi, more particular described as follows:

Parcel 22-19

100 FT E/S N JEFFERSON ST X 184 FT N/S HARDING ST IN 5 A LOT 10 NJ *CITY OF JACKSON LOT CLEANUP ASSESSMENT* PARCEL NO.: 22-19 HINDS COUNTY, FIRST JUDICIAL DISTRICT, MISSISSIPPI

Parcel 22-18

A part of Five Acre Lot No. 10 North Jackson according to the official map of said city made by J.C. Daniel in the year 1875 and more particularly described by metes and bounds as follows:

Beginning at a point on the East side of North Jefferson Street 100 feet North of the intersection of the North line of Harding Street (formerly called Oldham Street), with the East line of North Jefferson Street; thence running from said point of beginning East and parallel with the North line of Harding Street 234 feet; thence North and parallel with North Jefferson Street 60 feet 9 inches; thence West parallel with Harding Street 234 feet to the East line of North Jefferson Street; thence South along the east line of North Jefferson Street 60 feet 9 inches to the point of beginning; the said lot having a frontage on North Jefferson Street of 60 feet 9 inches and running back between parallel lines 234 feet.

And being the same property described in Instrument recorded in Book 7183 at Page 4722.

Parcel 22-17

Beginning the a point on the East line of Jefferson Street which point is 160.75 feet measured northerly along the East line of Jefferson Street from the Intersection of the East line of Jefferson Street with the North line of Oldham (Harding) Street; run thence northerly along the East line

of Jefferson Street 60.75 feet; run thence easterly and parallel with Oldham (Harding) Street 234 feet; run thence southerly and parallel with Jefferson Street 60.75 feet; run thence westerly and parallel with Oldham (Harding) Street 234 feet to the point of beginning.

And being the same property as described in Quitclaim Deed recorded in Book 7130 at Page 1750 and Warranty Deed recorded in Book 5850 at Page 200.

Parcel 23-16

That part of 5-acre Lot 7 North, in the City of Jackson, Mississippi, indicated on the map of said City made by H.C. Daniels in 1875, more particularly described by metes and bounds as follows:

For a point of beginning, commence at a point on the West line of N. Jefferson Street 414.3 feet measured southerly along the West line of N. Jefferson Street from the intersection of the West line of N. Jefferson Street with the South line of Boyd Street as both streets are now laid out and improved, said point of beginning being the northeast corner of the property hereby conveyed which is known as the Mary E. McGill property; thence run southerly along the West line of N. Jefferson street for a distance of 151.3 feet to the Spann property; thence westerly along the North line of the Spann property 157 feet, more or less, to the southeast corner of that certain property sold to Miss Mary E McGill and Richard F. McGill to James T. Canizaro on or about July 25, 1945; thence run in a northerly direction along the East line of the Canizaro property 49.92 feet to a point; thence run westwardly along the Canizaro property for 7 feet to a point; thence northwardly along the East line of the Canizaro property and along the East line of J. J. Neal property for 106 feet more or less to the northeast corner of the said J. J. Neal property and the northwest corner of the lands hereby conveyed; thence easterly in a straight line 163.5 feet, more or less, to the point of beginning on N. Jefferson Street.

There is also conveyed hereby all rights in and to a certain sewer line running across the Canizaro property to North Street, as amended by agreement of record in Deed Book 408, page 101 in the Chancery Clerk's office at Jackson, Mississippi, which rights were reserved in the deed afore-said to Canizaro of record in said Clerk's office in Deed Book 404, page 396 et.seq., reference to which deed and to the recitations therein and to the affidavits attached there-to is hereby made for greater certainty of deraignment of title to the lands hereby conveyed.

Parcel 22-20

Part of Five-acre Lot No. 10 North Jackson in said City particularly described as: Commencing at a point on the North line of Oldham or Harding Street, which point is 184 feet East of the intersection of said street with North Jefferson Street; run thence North parallel with Jefferson Street 92 ½ feet; thence East 50 feet; thence South 92 ½ feet; thence West 50 feet to the Point of Beginning, and being the same lot conveyed to David T. Flanagan by deed recorded in Book 323 at Page 10 of the land deed records of Hinds County, Mississippi.

Parcels 22-21 & 22-22

PARCEL A:

A CERTAIN LOT OR PARCEL OF LAND, FRONTING 45 FEET ON THE NORTH LINE OF HARDING STREET (FORMERLY OLDHAM STREET) AND RUNNING BACK NORTHERLY BETWEEN PARALLEL LINES FOR A DISTANCE OF 220 FEET, MORE OR LESS, TO THE PROPERTY FORMERLY OWNED BY JUDGE COOK, AND MORE PARTICULARLY DESCRIBED BY METES AND BOUNDS AS FOLLOWS, TO-WIT:

BEGINNING AT A POINT ON THE NORTH LINE OF HARDING STREET 279 FEET MEASURED EASTERLY ALONG THE NORTH LINE OF HARDING STREET FROM ITS INTERSECTION WITH THE EAST LINE OF NORTH JEFFERSON STREET, AS BOTH STREETS ARE NOW LAID OUT AND IMPROVED IN THE CITY OF JACKSON, MISSISSIPPI, RUNNING THENCE EASTERLY ALONG THE NORTH LINE OF HARDING STREET FOR A DISTANCE OF 45 FEET; THENCE TURNING TO THE LEFT THROUGH AN ANGLE OF 89 DEGREES 26 SECONDS, RUN NORTHERLY FOR A DISTANCE OF 220 FEET, MORE OR LESS, TO THE SOUTH LINE OF THE COOK PROPERTY; THENCE WESTERLY AND PARALLEL WITH THE NORTH LINE OF HARDING STREET FOR A DISTANCE OF 45 FEET; THENCE SOUTHERLY IN A STRAIGHT LINE 220 FEET, MORE

OR LESS, TO THE POINT OF BEGINNING, AND BEING A PART OF 5 ACRE LOT 10, NORTH JACKSON.

PARCEL B:

A PART OF 5-ACRE LOT TEN (10) NORTH ACCORDING TO H. C. DANIELS'S MAP OF THE CITY OF JACKSON, MISSISSIPPI, AND MORE PARTICULARLY DESCRIBED BY METES AND BOUNDS AS FOLLOWS, TO-WIT:

BEGINNING AT A POINT ON THE NORTH LINE OF HARDING STREET WHICH POINT IS 279 FEET MEASURED EASTERLY ALONG THE NORTH LINE OF HARDING STREET FROM THE INTERSECTION OF THE NORTH LINE OF HARDING STREET WITH THE EAST LINE OF NORTH JEFFERSON STREET AS BOTH STREETS ARE NOW LAID OUT AND IMPROVED IN THE CITY OF JACKSON, MISSISSIPPI; RUN THENCE WESTERLY ALONG THE NORTH LINE OF HARDING STREET FOR A DISTANCE OF 45 FEET; THENCE TURNING TTO THE RIGHT THROUGH AN ANGLE OF 90 DEGREES 24 SECONDS RUN NORTHERLY 220 FEET; RUN THENCE EASTERLY AND PARALLEL WITH THE NORTH LINE OF HARDING STREET FOR A DISTANCE OF 45 FEET; RUN THENCE SOUTHERLY 220 FEET TO THE POINT OF BEGINNING.

Parcels 25-4, 25-7 & 25-7-1

Beginning at a point on the south side of Harding Street, formerly Oldham Street, in the said City of Jackson, which point is 246 (248 measured) feet east of the intersection of the east line of North Jefferson Street with the south line of said Harding Street as said streets are now laid out and improved in the said City of Jackson and run thence 120 feet to a point; thence run east 52 feet to the point of beginning; said property being a part of the East Half of Lots Number Two (2) and Number Three (3) of Patton Subdivision of Five Acre Lot Number Eleven (11) North, as shown by plat recorded in Surveyor's Record Book "B" at Page 31 thereof in the office of the Chancery Clerk of Hinds County at Jackson, Mississippi, and the west half of a twenty-foot alley lying east of and adjacent to the property hereinabove described.

And being the same property as described in Quitclaim Deed recorded in Book 5318 at Page 134.

Fifty feet wide across and off the West side of Lot 4 of Pattons Subdivision of said City, a subdivision according to the map or plat thereof which is on file and of record in the office of the Chancery Clerk of Hands County, Mississippi, in Plat Book B at Page 31, reference to which is hereby made in aid of and as a part of this description and the East Half of a twenty-foot alley lying West of and adjacent to the property herein above described.

And being the same property as described in Quitclaim Deed recorded in Book 5314 at Page 510.

Parcel 25-8

10 feet off the East side of Lot 4 and 40 feet off the West side of Lot 5 of Pattons Subdivision, a subdivision according to the map or plat thereof which is on file and of record in the office of the Chancery Clerk of Hinds County at Jackson, Mississippi, in Plat Book B at Page 31, reference to which is hereby made in aid of and as a part of this description.

Parcel 25-49

20 FT E/S LOT 5 & 30 FT W/S LOT 6 PATTONS SUBN 5 A LOT 11 NJ

is hereby modified so as to approve the rezoning of the properties located at 804, 814, 818 & 823 N. Jefferson St. (Parcels #22-19, 22-18, 22-17, 23-16), 920, 924, 927, 928, 935, 937 Harding St. (Parcels #22-20, 22-21, 25-4, 22-22, 25-7, 25-8) and Parcels 25-7-1 & 25-49 Harding St. from R-1 (Single-Family) Residential District to NMU-1 (Neighborhood) Mixed-Use District, Pedestrian Oriented to allow for consistency with the zoning in the immediate vicinity of the properties and for a compatible diversity of land uses and a Use Permit be granted for Parcel 22-19 to allow for accessory parking. However, before any structure is erected or use thereof on the said property, the applicant must meet the requirements established through

the Site Plan Review process. The Zoning Administrator is ordered to note such change on the Official Zoning Map to the City of Jackson, Mississippi.

SECTION 2. That the cost of publication of this Ordinance shall be borne by the petitioner.

SECTION 3. That this Ordinance shall be effective thirty (30) days after its passage and after publication of same by the petitioner.

Council Member Lindsay moved adoption; **Council Member Banks** seconded.

President Foote recognized **Jennifer Welch**, Applicant and **Brad Reeves**, Attorney for Applicant, who spoke in favor of a **Rezoning** from R-1 (Single-Family) Residential District to NMU-1 (Neighborhood) Mixed-Use District, Pedestrian Oriented for the properties located at 804, 814, 818 & 823 N. Jefferson St. (Parcels #22-19, 22-18, 22-17, 23-16), 920, 924, 927, 928, 935, 937 Harding St. (Parcels #22-20, 22-21, 25-4, 22-22, 25-7, 25-8) and Parcels 25-7-1 & 25-49 Harding St. with a **Use Permit** for Parcel 22-19 to allow for accessory parking for businesses located at 730, 750 and 752 N. Jefferson St. in addition to the Oaks House Museum and Urban Foxes at 833 N. Jefferson St. & duplex at 818 N. Jefferson.

There was no opposition from the public.

Thereafter, **President Foote** called for a vote on said item:

- Yeas – Banks, Foote, Grizzell, Lee and Lindsay.
- Nays – None
- Absent – Hartley and Stokes.

Note: **Council Member Grizzell** left the meeting.

President Foote requested that the Clerk read the Order:

ORDER GRANTING EXTENSION OF SPECIAL EXCEPTIONS AND USE PERMITS FOR ONE YEAR.

Coming for consideration are requests for the approval of the following for certification of renewal for one year and after the anniversary date of approval for Use Permit or Special Exceptions as follows:

<u>CASE NO.</u>	<u>NAME</u>	<u>LOCATION</u>	<u>USE</u>	<u>GRANTED</u>
SE – 3862 Ward 7	Millsaps College	1702 N. State St. Jackson, MS 39206	Office/Meeting Spaces & Administrative Units	05/19/14
C-UP-4166 Ward 2	John W. Craig & Lynn Nguyen	6351 I-55 N. Frontage Rd. - Suite 147 Jackson, MS 39206	Operation of a Graphic Arts Studio w/ Professional Tattooing	5/16/22

IT IS HEREBY ORDERED by the Council of the City of Jackson that the said Use Permits and/or special Exceptions be and the same are hereby extended for another year from and after the anniversary date granting said permits.

**REGULAR ZONING MEETING OF THE CITY COUNCIL
MONDAY, MAY 15, 2023 2:30 P.M.**

Council Member Banks moved adoption; **Council Member Lindsay** seconded.

Yeas – Banks, Foote, Lee and Lindsay.
Nays – None
Absent – Grizzell, Hartley and Stokes.

* * * * *

There being no further business to come before the City Council, it was unanimously voted to adjourn until the next Regular Council Meeting to be held at 10:00 a.m. on Tuesday, May 23, 2023. At 2:55 p.m., the Council stood adjourned.

PREPARED BY:

APPROVED:

CLERK OF COUNCIL

_____, _____
COUNCIL PRESIDENT DATE

MAYOR

ATTEST:

CITY CLERK

* * * * *

8

OFFICE OF THE CITY ATTORNEY
4/26/23

RESOLUTION DECLARING CERTAIN PARCELS OF REAL PROPERTY IN THE CITY OF JACKSON TO BE A MENACE TO PUBLIC HEALTH, SAFETY, AND WELFARE PURSUANT TO SECTION 21-19-11 OF THE MISSISSIPPI CODE AND BASED ON ADMINISTRATIVE HEARINGS HELD ON FEBRUARY 7, 2023 FOR THE FOLLOWING CASES:

21-204	21-494	21-887	22-1054	22-1825	22-2163
21-205	22-716	22-910	22-1386	22-1953	22-2165
22-228	21-788	22-1003	22-1496	22-2034	22-2307
22-431	22-791	22-1011	22-1529	22-2079	22-2319
22-463	21-842	22-1053	21-1648	22-2121	

WHEREAS, Section 21-19-11 of the Mississippi Code, as amended, provides that a governing authority shall conduct a hearing to determine whether property or parcels of land located within a municipality is in such a state of uncleanliness as to be a menace to the public health, safety, and welfare of the community; and

WHEREAS, Section 21-19-11 of the Mississippi Code as amended sets forth the procedure for mailing and posting notice of the hearing; and

WHEREAS, hearings were held on February 7, 2023; and

WHEREAS, the hearing officer determined that notice was provided in accordance with Section 21-19-11 prior to the hearings; and

WHEREAS, after hearing testimony and reviewing evidence, the hearing officer made findings and recommendations for adjudication concerning certain parcels as follows:

- 1) **Case #22-1496: Parcel #633-43** located at 1170 McDowell Cir.: No appearance by owner or an interested party. Hearing officer recommends that the property be adjudicated as a menace to public health, safety, and welfare with assessment of actual costs and a penalty of \$500.00. Ward 6

Scope of Work: Cut grass, weeds, shrubbery, fence line, bushes, saplings as needed. Remove trash and debris. Remove inoperable vehicle(s) or vehicle(s) parked on grass.

- 2) **Case #22-2307: Parcel #853-34** located at 590 Chelsea Dr.: No appearance by owner or an interested party. Hearing officer recommends that the property be adjudicated as a menace to public health, safety, and welfare with assessment of actual costs and a penalty of \$500.00. Ward 6

Scope of Work: Remove trash and debris. Remove inoperable vehicle(s) or vehicle(s) parked on grass.

- 3) **Case #22-2165: Parcel #842-272** located at 149 Sharon Hill Dr.: No appearance by owner or an interested party. Hearing officer recommends that the property be adjudicated as a menace to public health, safety, and welfare with assessment of actual costs and a penalty of \$500.00. Ward 4

Scope of Work: Remove trash and debris. Remove inoperable vehicle(s) or vehicle(s) parked on grass.

- 4) **Case #22-2319: Parcel #853-267** located at 3914 Forest Lake Dr.: No appearance by owner or an interested party. Hearing officer recommends that the property be adjudicated as a menace to public health, safety, and welfare with assessment of actual costs and a penalty of \$500.00. Ward 6

Scope of Work: Board up and/or secure structure(s). Cut grass, weeds, shrubbery, fence line, bushes, saplings as needed. Remove trash and debris.

- 5) **Case #22-2121: Parcel #627-204** located at 3853 Meadow Lane Rd.: No appearance by owner or an interested party. Hearing officer recommends that the property be adjudicated as a menace to public health, safety, and welfare with assessment of actual costs and a penalty of \$500.00. Ward 6

Scope of Work: Cut grass, weeds, shrubbery, fence line, bushes, and saplings as needed. Remove trash and debris.

- 6) **Case # 22-2034: Parcel #633-183** located at 1303 Maria Dr.: No appearance by owner or an interested party. Hearing officer recommends that the property be adjudicated as a menace to public health, safety, and welfare with assessment of actual costs. Ward 6

Scope of Work: Demolish and remove remains of dilapidated structure, trash, debris, foundation, steps, driveway, tires, and any other items to insure property is clear and free of any and all health hazards. Cut grass, weeds, shrubbery, fence line, bushes, saplings as needed.

- 7) **Case #22-228: Parcel #721-834** located at 2267 Forest Glen Dr.: No appearance by owner or an interested party. Hearing officer recommends that the property be adjudicated as a menace to public health, safety, and welfare with assessment of actual costs and a penalty of \$500.00. Ward 2

Scope of Work: Cut grass, weeds, shrubbery, fence line, bushes, and saplings as needed. Remove trash and debris.

- 8) **Case #22-1386: Parcel #432-360** located at 4613 Churchill Dr.: No appearance by owner or an interested party. Hearing officer recommends that the property be adjudicated as a menace to public health, safety, and welfare with assessment of actual costs and a penalty of \$750.00. Ward 3

Scope of Work: Cut grass, weeds, shrubbery, fence line, bushes, and saplings as needed. Remove trash and debris.

- 9) **Case #21-788: Parcel #821-713** located at 1021 Capri Cir.: No appearance by owner or an interested party. Hearing officer recommends that the property be adjudicated as a menace to public health, safety, and welfare with assessment of actual costs and a penalty of \$750.00. Ward 4

Scope of Work: Remove trash and debris, cut grass, weeds and remove inoperable vehicles or vehicles parked on the grass.

- 10) **Case #21-494: Parcel #212-271** located at 1850 Elaine St.: No appearance by owner or an interested party. Hearing officer recommends that the property be adjudicated as a menace to public health, safety, and welfare with assessment of actual costs and a penalty of \$500.00. Ward 5

Scope of Work: Cut grass, weeds, shrubbery, fence line, bushes, saplings as needed. Board up and/or secure structure(s). Remove trash and debris.

- 11) **Case #21-204: Parcel #633-153** located at 1115 Barbara Ann Dr.: No appearance by owner or an interested party. Hearing officer recommends that the property be adjudicated as a menace to public health, safety, and welfare with assessment of actual costs and a penalty of \$750.00. Ward 6

Scope of Work: Board up and secure structure(s). Cut grass, weeds, shrubbery, fence line, bushes, and saplings as needed. Remove trash and debris.

- 12) **Case #21-205: Parcel #842-294** located at 359 Sharon Hills Dr.: No appearance by owner or an interested party. Hearing officer recommends that the property be adjudicated as a menace to public health, safety, and welfare with assessment of actual costs and a penalty of \$750.00. Ward 4

Scope of Work: Cut grass, weeds, shrubbery, fence line, bushes, saplings as needed. Remove trash and debris. Remove inoperable vehicle(s) or vehicle(s) parked on grass.

- 13) **Case #21-1648: Parcel #839-231** located at 1051 Deryll St.: No appearance by owner or an interested party. Hearing officer recommends that the property be adjudicated as a menace to public health, safety, and welfare with assessment of actual costs and a penalty of \$750.00. Ward 6

Scope of Work: Board up and/or secure structure(s). Cut grass, weeds, shrubbery, fence line, bushes, saplings as needed. Remove trash and debris.

- 14) **Case #22-2163: Parcel #606-133** located at 2831 Kingswood Ave.: No appearance by owner or an interested party. Hearing officer recommends that the property be adjudicated as a menace to public health, safety, and welfare with assessment of actual costs and a penalty of \$750.00. Ward 7

Scope of Work: Demolish and remove remains of dilapidated structure, trash, debris, foundation, steps, driveway, tires, and any other items to insure property is clear and free of any and all health hazards. Cut grass, weeds, shrubbery, fence line, bushes, saplings as needed.

- 15) **Case #22-463: Parcel #104-155** located at 2280 Decatur St.: No appearance by owner or an interested party. Hearing officer recommends that the property be adjudicated as a menace to public health, safety, and welfare with assessment of actual costs and a penalty of \$750.00. Ward 3

Scope of Work: Demolish and remove remains of dilapidated structure, trash, debris, foundation, steps, driveway, tires, and any other items to insure property is clear and free of any and all health hazards. Cut grass, weeds, shrubbery, fence line, bushes, saplings as needed.

- 16) **Case #22-1529: Parcel #410-77** located at 3621 Gammill St.: No appearance by owner or an interested party. Hearing officer recommends that the property be adjudicated as a menace to public health, safety, and welfare with assessment of actual costs and a penalty of \$750.00. Ward 3

Scope of Work: Cut grass, weeds, shrubbery, fence line, bushes, and saplings as needed. Remove trash and debris.

- 17) **Case #22-1825: Parcel # 723-665** located at 418 Lake Dr.: No appearance by owner or an interested party. Hearing officer recommends that the property be adjudicated as a menace to public health, safety, and welfare with assessment of actual costs and a penalty of \$500.00. Ward 2

Scope of Work: Remove trash and debris.

- 18) **Case #22-1011: Parcel #162-281** located at 1623 Barrett Ave.: No appearance by owner or an interested party. Hearing officer recommends that the property be held in abeyance and be adjudicated as a menace to public health, safety, and welfare with assessment of actual costs and a penalty of \$750.00. Ward 5

Scope of Work: Demolish and remove remains of dilapidated structure, trash, debris, foundation, steps, driveway, tires, and any other items to insure property is clear and free of

any and all health hazards. Cut grass, weeds, shrubbery, fence line, bushes, saplings as needed.

- 19) **Case #21-842: Parcel #101-45** located at 2860 Bishop St.: No appearance by owner or an interested party. Hearing officer recommends that the property be held in abeyance and be adjudicated as a menace to public health, safety, and welfare with assessment of actual costs and a penalty of \$750.00. Ward 5

Scope of Work: Board up and/or secure structure(s). Cut grass, weeds, shrubbery, fence line, bushes, saplings as needed. Remove trash and debris.

- 20) **Case #22-1054: Parcel #410-395** located at 3702 Skyline Dr.: No appearance by owner or an interested party. Hearing officer recommends that the property be held in abeyance and be adjudicated as a menace to public health, safety, and welfare with assessment of actual costs and a penalty of \$750.00. Ward 3

Scope of Work: Demolish and remove remains of dilapidated structure, trash, debris, foundation, steps, driveway, tires, and any other items to insure property is clear and free of any and all health hazards. Cut grass, weeds, shrubbery, fence line, bushes, saplings as needed.

- 21) **Case #22-1053: Parcel #410-394** located at 3648 Skyline Dr.: No appearance by owner or an interested party. Hearing officer recommends that the property be adjudicated as a menace to public health, safety, and welfare with assessment of actual costs and a penalty of \$750.00. Ward 3

Scope of Work: Demolish and remove remains of dilapidated structure, trash, debris, foundation, steps, driveway, tires, and any other items to insure property is clear and free of any and all health hazards. Cut grass, weeds, shrubbery, fence line, bushes, saplings as needed.

- 22) **Case #21-887: Parcel #523-266** located at 716 Kirkley Dr.: After hearing testimony from owner Connie Anderson, hearing officer recommends that the property be adjudicated as a menace to public health, safety, and welfare; however, Connie Anderson shall be afforded thirty (30) days or until March 9, 2023 to cure the violations by completing the scope of work. If there is a default and the City proceeds with cleaning, hearing officer recommends an assessment of actual costs and a penalty of \$500.00. Ward 2

Scope of Work: Cut grass, weeds, shrubbery, fence line, bushes, and saplings as needed. Remove trash and debris.

- 23) **Case #22-431: Parcel #97-192** located at 445 Vardaman St.: No appearance by owner or an interested party. Hearing officer recommends that the property be adjudicated as a menace to public health, safety, and welfare with assessment of actual costs and a penalty of \$750.00. Ward 3

Scope of Work: Remove trash and debris.

- 24) **Case #22-1953: Parcel #425-33-1** located at 3811 Mosley Ave.: No appearance by owner or an interested party. Hearing officer recommends that the property be adjudicated as a menace to public health, safety, and welfare with assessment of actual costs and a penalty of \$1,500.00. Ward 3

Scope of Work: Remove trash and debris.

- 25) **Case #22-1003: Parcel #410-86** located at 3552 Cromwell St.: No appearance by owner or an interested party. Hearing officer recommends that the property be adjudicated as a menace to public health, safety, and welfare with assessment of actual costs and a penalty of \$750.00. Ward 3

Scope of Work: Cut grass, weeds, shrubbery, fence line, bushes, and saplings as needed. Remove trash and debris.

- 26) **Case #22-2079: Parcel #821-712** located at 1023 Capri Cir.: No appearance by owner or an interested party. Hearing officer recommends that the property be adjudicated as a menace to public health, safety, and welfare with assessment of actual costs and a penalty of \$750.00. Ward 4

Scope of Work: Demolish and remove remains of the dilapidated structure, trash, debris, foundation, steps, driveway, tires, and any other items to insure the property is clear and free of any and all health hazards. Cut grass, weeds, shrubbery, fence line, bushes, saplings as needed.

- 27) **Case #22-910: Parcel #825-261** located at 5821 Fairchild St.: After hearing testimony from owner John H. Smith, hearing officer recommends that the property be adjudicated as a menace to public health, safety, and welfare; however, John H. Smith shall be afforded forty-five (45) days until March 24, 2023 to cure the violations by completing the scope of work. If there is a default and the City proceeds with cleaning, hearing officer recommends an assessment of actual costs and a penalty of \$500.00. Ward 4

Scope of Work: Cut grass, weeds, shrubbery, fence line, bushes, saplings as needed. Remove trash and debris. Remove inoperable vehicle(s) or vehicle(s) parked on grass.

- 28) **Case #22-791: Parcel #306-323** located at 108 Sanford St.: No appearance by owner or an interested party. Hearing officer recommends that the property be adjudicated as a

menace to public health, safety, and welfare with assessment of actual costs and a penalty of \$500.00. Ward 4

Scope of Work: Cut grass, weeds, shrubbery, fence line, bushes, and saplings as needed. Remove trash and debris.

- 29) **Case #22-716: Parcel #629-253** located at 722 Westmont Dr.: After hearing testimony from owner Zachary Cornelius Moore, hearing officer recommends that the property be adjudicated as a menace to public health, safety, and welfare; however, Zachary Cornelius Moore shall be afforded forty-five (45) days until March 24, 2023 to cure the violations by completing the scope of work. If there is a default and the City proceeds with cleaning, hearing officer recommends an assessment of actual costs and a penalty of \$500.00. Ward 5

Scope of Work: Demolish and remove remains of the dilapidated structure, trash, debris, foundation, steps, driveway, tires, and any other items to insure the property is clear and free of any and all health hazards. Cut grass, weeds, shrubbery, fence line, bushes, saplings as needed.

IT IS HEREBY ORDERED that the above parcels be adjudicated a menace to public health, safety, and welfare as recommended by the hearing officer.

IT IS HEREBY ORDERED that a copy of the notices mailed and posted to owners and interested parties of the above parcels shall be included in the minutes along with this resolution pursuant to Section 21-19-11 of the Mississippi Code as amended.

IT IS HEREBY ORDERED that the Administration shall be authorized to remedy conditions on the parcels posing a threat to public health and safety using municipal resources or contract labor if the owners fail to do so.

IT IS HEREBY ORDERED that the adjudication of penalties, if any, shall be reserved until such time that a resolution is approved assessing actual costs.

ITEM# _____

AGENDA _____

CITY COUNCIL AGENDA ITEM 10 POINT DATA SHEET

3/3/2023
DATE

P O I N T S		C O M M E N T S					
1.	Brief Description/Purpose	This is Community Improvement regular agenda item for the City Council authority to clean private property.					
2.	Public Policy Initiative <ol style="list-style-type: none"> 1. Youth & Education 2. Crime Prevention 3. Changes in City Government 4. Neighborhood Enhancement 5. Economic Development 6. Infrastructure and Transportation 7. Quality of Life 	<ol style="list-style-type: none"> 1. Neighborhood Enhancement 2. Crime Prevention 7. Quality of Life 					
3.	Who will be affected	All City of Jackson residents					
4.	Benefits	The cleaning of the private properties will improve the conditions of communities and will also remove threats to the health, safety and welfare of surrounding residents.					
5.	Schedule (beginning date)	To be determined pending execution of contracts.					
6.	Location: <ul style="list-style-type: none"> ▪ WARD ▪ CITYWIDE (yes or no) (area) ▪ Project limits if applicable 	CITYWIDE					
7.	Action implemented by: <ul style="list-style-type: none"> ▪ City Department <input type="checkbox"/> ▪ Consultant <input type="checkbox"/> 	PLANNING AND DEVELOPMENT DEPARTMENT COMMUNITY IMPROVEMENT DIVISION					
8.	COST	To be determined pending execution of contracts.					
9.	Source of Funding <ul style="list-style-type: none"> ▪ General Fund ▪ Grant <input type="checkbox"/> ▪ Bond <input type="checkbox"/> ▪ Other <input type="checkbox"/> 	GENERAL FUNDING					
10.	EBO participation	ABE	_____ %	WAIVER	yes _____	no _____	N/A _____
		AABE	_____ %	WAIVER	yes _____	no _____	N/A _____
		WBE	_____ %	WAIVER	yes _____	no _____	N/A _____
		HBE	_____ %	WAIVER	yes _____	no _____	N/A _____
		NABE	_____ %	WAIVER	yes _____	no _____	N/A _____

Jackson Police Department
Community Improvement Unit



327 East Pascagoula Street
Post Office Box 17
Jackson, Mississippi 39205-0017

MEMORANDUM

TO: Mayor Choke A. Lumumba

Via: Chloe Dotson
Director, Planning and Development

lum

From: Community Improvement
Planning and Development

DATE: February 12, 2023

Re: Agenda Item

The attached agenda item is a Resolution declaring certain parcel of real property in the City of Jackson to be a menace to public health, safety, and welfare pursuant to section 21-19-11 of Mississippi Code. Therefore, we request that you authorize cleaning.

Thank you for your consideration.

Office of the City Attorney

455 East Capitol Street
Post Office Box 2779
Jackson, Mississippi 39207-2779
Telephone: (601) 960-1799
Facsimile: (601) 960-1756

OFFICE OF THE CITY ATTORNEY

This RESOLUTION DECLARING CERTAIN PARCELS OF REAL PROPERTY IN THE CITY OF JACKSON TO BE A MENACE TO PUBLIC HEALTH, SAFETY, AND WELFARE PURSUANT TO SECTION 21-19-11 OF THE MISSISSIPPI CODE AND BASED ON ADMINISTRATIVE HEARINGS HELD FEBRUARY 7, 2023 FOR THE FOLLOWING CASES: 21-204 21-205 22-228 22-431 22-463 21-494 22-716 21-788 22-791 21-842 21-887 22-910 22-1003 22-1011 22-1053 22-1054 22-1386 22-1496 22-1529 21-1648 22-1825 22-1953 22-2034 22-2079 22-2121 22-2163 22-2165 22-2307 22-2319 is legally sufficient for placement in NOVUS Agenda.



Catoria Martin, City Attorney

Kristie Metcalfe, Deputy City Attorney 

5/3/23

Date

OFFICE OF THE CITY ATTORNEY
5/3/23

9

OFFICE OF THE CITY ATTORNEY
pkc
4/26/23

RESOLUTION DECLARING CERTAIN PARCELS OF REAL PROPERTY IN THE CITY OF JACKSON TO BE A MENACE TO PUBLIC HEALTH, SAFETY, AND WELFARE PURSUANT TO SECTION 21-19-11 OF THE MISSISSIPPI CODE AND BASED ON ADMINISTRATIVE HEARINGS HELD JANUARY 24, 2023 FOR THE FOLLOWING CASES:

21-526	21-747	22-335	22-1543	22-1809	22-1961
22-2173	22-2176	21-355	21-475	21-540	21-1177
21-1992	21-2032	21-1193	22-1767		

WHEREAS, Section 21-19-11 of the Mississippi Code as amended provides that a governing authority shall conduct a hearing to determine whether property or parcels of land located within a municipality is in such a state of uncleanness as to be a menace to the public health, safety and welfare of the community; and

WHEREAS, Section 21-19-11 of the Mississippi Code as amended sets forth the procedure for mailing and posting notice of the hearing; and

WHEREAS, hearings were held on January 24, 2023; and

WHEREAS, the hearing officer determined that notice was provided in accordance with Section 21-19-11 prior to the hearings; and

WHEREAS, after hearing testimony and reviewing evidence, the hearing officer made findings and recommendations for adjudication concerning certain parcels as follows:

- 1) **Case #21-526: Parcel #607-25** located at 115 Cedar Lane.: No appearance by the owner or an interested party. The hearing officer recommends that the property be adjudicated as a menace to public health, safety, and welfare. Ward 7

Scope of Work: Board up and secure structure, cut grass, weeds, shrubbery, fence line, bushes, and saplings; remove the trash, debris, wooden boards/crates, appliances/old furniture, building materials/old bricks, tree limbs & parts, tires; and clean curbside.

- 2) **Case #21-747: Parcel #854-40** located at 111 Glenstone Cir.: After hearing testimony from Kire Parson, the hearing officer recommends that the property be adjudicated as a menace to public health, safety, and welfare. However, Kire Parson shall be afforded thirty (30) days, or until February 23, 2023, to cure the violations by completing the scope of work. Ward 4

Scope of Work: Cut grass, weeds, shrubbery, fence line, bushes, and saplings; remove the trash, debris, wooden boards/crates, appliances/old furniture, building materials/old bricks, tree limbs & parts, and tires; and clean curbside. Remove trash and debris, inoperable vehicles, or vehicles parked on the lawn.

- 3) **Case #22-335: Parcel #837-40** located at 2474 Vernon Dr. After hearing testimony from owner Velasquez Nicandro, the hearing officer recommends that the property be adjudicated as a menace to public health, safety, and welfare. However, Velasquez Nicandro shall be afforded fifteen (15) days, or until February 8, 2023, to cure the violations by completing the scope of work. If there is a default and the City proceeds with cleaning, the hearing officer recommends an assessment of actual costs and a penalty of \$500.00. Ward 5

Scope of Work: Demolish and remove remains of the dilapidated structure, trash, debris, foundation, steps, driveway, tires, and any other items to ensure the property is clear and free of any and all health hazards and cut grass and weeds.

- 4) **Case #22-1543: Parcel #616-79** located at 2723 Emerald Dr.: No appearance by the owner or an interested party. The hearing officer recommends that the property be adjudicated as a menace to public health, safety, and welfare with an assessment of actual costs and a penalty of \$500.00. Ward 6

Scope of Work: Demolish and remove remains of the dilapidated structure, trash, debris, foundation, steps, driveway, tires, and any other items to ensure the property is clear and free of any and all health hazards and cut grass and weeds.

- 5) **Case #22-1809: Parcel #211-387** located at 943 Stuart St.: No appearance by the owner or an interested party. The hearing officer recommends that the property be adjudicated as a menace to public health, safety, and welfare with an assessment of actual costs and a penalty of \$750.00. Ward 6

Scope of Work: Demolish and remove remains of the dilapidated structure, trash, debris, foundation, steps, driveway, tires, and any other items to ensure the property is clear and free of any and all health hazards and cut grass and weeds.

- 6) **Case #22-1961: Parcel #633-452** located at 2383 Breckinridge Rd.: No appearance by the owner or an interested party. The hearing officer recommends that the property be adjudicated as a menace to public health, safety, and welfare with an assessment of actual costs and a penalty of \$500.00. Ward 6

Scope of Work: Demolish and remove remains of the dilapidated structure, trash, debris, foundation, steps, driveway, tires, and any other items to ensure the property is clear and free of any and all health hazards and cut grass and weeds.

- 7) **Case #22-2173: Parcel #606-347** located at 431 Sennett Ave.: No appearance by the owner or an interested party. The hearing officer recommends that the property be adjudicated as a menace to public health, safety, and welfare with an assessment of actual costs and a penalty of \$500.00. Ward 7

Scope of Work: Demolish and remove remains of the dilapidated structure, trash, debris, foundation, steps, driveway, tires, and any other items to ensure the property is clear and free of any and all health hazards and cut grass and weeds.

- 8) **Case #22-2176: Parcel #606-348** located at 441 Sennett Ave.: No appearance by the owner or an interested party. The hearing officer recommends that the property be adjudicated as a menace to public health, safety, and welfare with an assessment of actual costs and a penalty of \$500.00. Ward 7

Scope of Work: Demolish and remove remains of the dilapidated structure, trash, debris, foundation, steps, driveway, tires, and any other items to ensure the property is clear and free of any and all health hazards and cut grass and weeds.

- 9) **Case #21-355: Parcel #805-290** located at 6728 George Washington Dr.: No appearance by the owner or an interested party. The hearing officer recommends that the property be adjudicated as a menace to public health, safety, and welfare with an assessment of actual costs and a penalty of \$500.00. Ward 2

Scope of Work: Cut grass, weeds, shrubbery, fence line, bushes, and saplings, and remove trash and debris.

- 10) **Case #21-475: Parcel #410-60** located at 2727 Miller Ave. After hearing testimony from Lamarus Taylor, the hearing officer recommends that the property be adjudicated as a menace to public health, safety, and welfare. However, Lamarus Taylor shall be afforded thirty (30) days, or until February 23, 2023, to cure the violations by completing the scope of work. Ward 3

Scope of Work: Cut grass, weeds, shrubbery, fence line, bushes, and saplings, and remove trash and debris.

- 11) **Case #21-540: Parcel #409-86** located at 1938 Corley Ave.: After hearing testimony from owner Oscar Lee Stewart, the hearing officer recommends that the property be adjudicated as a menace to public health, safety, and welfare. However, Oscar Lee Stewart shall be afforded sixty (60) days, or until March 25, 2023, to cure the violations by completing the scope of work. If there is a default and the City proceeds with cleaning, the hearing officer recommends an assessment of actual costs and a penalty of \$500.00. Ward 3

Scope of Work: Demolish and remove remains of the dilapidated structure, trash, debris, foundation, steps, driveway, tires, and any other items to ensure the property is clear and free of any and all health hazards and cut grass and weeds.

- 12) **Case #21-1177: Parcel #713-183** located at 1924 Hamilton Blvd.: No appearance by the owner or an interested party. The hearing officer recommends that the property be adjudicated as a menace to public health, safety, and welfare with an assessment of actual costs and a penalty of \$500.00. Ward 2

Scope of Work: Remove trash and debris, inoperable vehicles, or vehicles parked on the lawn.

- 13) **Case #21-1992: Parcel #409-282** located at 1833 Oakland Ave.: No appearance by the owner or an interested party. The hearing officer recommends that the property be

adjudicated as a menace to public health, safety, and welfare with an assessment of actual costs and a penalty of \$500.00. Ward 3

Scope of Work: Demolish and remove remains of the dilapidated structure, trash, debris, foundation, steps, driveway, tires, and any other items to ensure the property is clear and free of any and all health hazards and cut grass and weeds

- 14) **Case #21-2032: Parcel #637-8** located at 4837 Clinton Blvd.: No appearance by the owner or an interested party. The hearing officer recommends that the property be adjudicated as a menace to public health, safety, and welfare with an assessment of actual costs and a penalty of \$500.00. Ward 4

Scope of Work: Remove trash and debris, inoperable vehicles, or vehicles parked on the lawn.

- 15) **Case #21-1193: Parcel #821-305** located at 1424 Pear St.: After hearing testimony from owner Brown Theodore, the hearing officer recommends that the property be adjudicated as a menace to public health, safety, and welfare. However, Brown Theodore shall be afforded twenty (25) days, or until February 28, 2023, to cure the violations by completing the scope of work. If there is a default and the City proceeds with cleaning, the hearing officer recommends an assessment of actual costs and a penalty of \$500.00. Ward 4

Scope of Work: Demolish and remove remains of the dilapidated structure, trash, debris, foundation, steps, driveway, tires, and any other items to ensure the property is clear and free of any and all health hazards and cut grass and weeds.

- 16) **Case #22-1767: Parcel #164-1** located at 1141 University Blvd.: After hearing testimony from owner Al Shami Investments LLC, the hearing officer recommends that the property be adjudicated as a menace to public health, safety, and welfare. However, Al Shami Investments LLC shall be afforded twenty-one (21) days, or until February 14, 2023, to cure the violations by completing the scope of work. If there is a default and the City proceeds with cleaning, the hearing officer recommends an assessment of actual costs and a penalty of \$500.00. Ward 5

Scope of Work: Demolish and remove remains of the dilapidated structure, trash, debris, foundation, steps, driveway, tires, and any other items to ensure the property is clear and free of any and all health hazards and cut grass and weeds.

IT IS HEREBY ORDERED that the above parcels be adjudicated a menace to public health as recommended by the hearing officer.

IT IS HEREBY ORDERED that a copy of the notices mailed and posted to owners and interested parties of the above parcels shall be included in the minutes along with this resolution pursuant to Section 21-19-11 of the Mississippi Code as amended.

IT IS HEREBY ORDERED that the adjudication of penalties, if any, shall be reserved until such time that a resolution is approved assessing actual costs.

ITEM# _____
AGENDA _____

CITY COUNCIL AGENDA ITEM 10 POINT DATA SHEET

02/13/2023
DATE

POINTS		COMMENTS
1.	Brief Description/Purpose	This is Community Improvement regular agenda for the City Council authority to clean private property.
2.	Public Policy Initiative 1. Youth & Education 2. Crime Prevention 3. Changes in City Government 4. Neighborhood Enhancement 5. Economic Development 6. Infrastructure and Transportation 7. Quality of Life	1. Neighborhood Enhancement 2. Crime Prevention 7. Quality of Life
3.	Who will be affected	All City of Jackson residents
4.	Benefits	The cleaning of the private properties will improve the conditions of communities and will also remove threats to the health, safety and welfare of surrounding residents.
5.	Schedule (beginning date)	To be determined pending execution of contracts.
6.	Location: ▪ WARD ▪ CITYWIDE (yes or no) (area) ▪ Project limits if applicable	CITYWIDE
7.	Action implemented by: City Department <input type="checkbox"/> ▪ Consultant <input type="checkbox"/>	PLANNING AND DEVELOPMENT DEPARTMENT COMMUNITY IMPROVEMENT DIVISION
8.	COST	To be determined pending execution of contracts.
9.	Source of Funding ▪ General Fund ▪ Grant <input type="checkbox"/> ▪ Bond <input type="checkbox"/> ▪ Other <input type="checkbox"/>	COMMUNITY IMPROVEMENT DEVELOPMENT BLOCK GRANT FUNDS GENERAL FUNDS
10.	EBO participation	ABE _____ % WAIVER yes _____ no _____ N/A _____ AABE _____ % WAIVER yes _____ no _____ N/A _____ WBE _____ % WAIVER yes _____ no _____ N/A _____ HBE _____ % WAIVER yes _____ no _____ N/A _____ NABE _____ % WAIVER yes _____ no _____ N/A _____

Department of Planning and Development
Community Improvement Division

200 South President Street
Post Office Box 17
Jackson, Mississippi 39205-0017

MEMORANDUM

TO: Mayor Choke A. Lumumba

VIA: Chloe Dotson
Director, Planning and Development

FROM: Community Improvement Planning and Development 

DATE: 02/13/2023

RE: Agenda Item

The attached agenda item is a Resolution declaring a certain parcel of real property in the City of Jackson to be a menace to public health, safety, and welfare pursuant to section 21-19-11 of the Mississippi Code. Therefore, we request that you authorize cleaning.

Thank you for your consideration.

Office of the City Attorney

455 East Capitol Street
Post Office Box 2779
Jackson, Mississippi 39207-2779
Telephone: (601) 960-1799
Facsimile: (601) 960-1756

OFFICE OF THE CITY ATTORNEY

This RESOLUTION DECLARING CERTAIN PARCELS OF REAL PROPERTY IN THE CITY OF JACKSON TO BE A MENACE TO PUBLIC HEALTH, SAFETY, AND WELFARE PURSUANT TO SECTION 21-19-11 OF THE MISSISSIPPI CODE AND BASED ON ADMINISTRATIVE HEARINGS HELD JANUARY 24, 2023 FOR THE FOLLOWING CASES: 21-526 22-2173 21-1992 21-747 22-2176 21-2032 22-335 21-355 21-1193 22-1543 21-475 22-1767 22-1809 21-40 22-1961 21-1177 is legally sufficient for placement in NOVUS Agenda.



Catoria Martin, *City Attorney*

Kristie Metcalfe, *Deputy City Attorney*



5/3/23
Date

OFFICE OF THE CITY ATTORNEY
5/3/23

10

OFFICE OF THE CITY ATTORNEY
6/10/23

RESOLUTION DECLARING CERTAIN PARCELS OF REAL PROPERTY IN THE CITY OF JACKSON TO BE A MENACE TO PUBLIC HEALTH, SAFETY, AND WELFARE PURSUANT TO SECTION 21-19-11 OF THE MISSISSIPPI CODE AND BASED ON ADMINISTRATIVE HEARINGS HELD MARCH 21, 2023 FOR THE FOLLOWING CASES:

**22-410 23-624 22-2523 22-2106 22-1949 22-1860
22-1199**

WHEREAS, Section 21-19-11 of the Mississippi Code as amended provides that a governing authority shall conduct a hearing to determine whether property or parcels of land located within a municipality is in such a state of uncleanliness as to be a menace to the public health, safety and welfare of the community; and

WHEREAS, Section 21-19-11 of the Mississippi Code as amended sets forth the procedure for mailing and posting notice of the hearing; and

WHEREAS, hearings were held on March 21, 2023; and

WHEREAS, the hearing officer determined that notice was provided in accordance with Section 21-19-11 prior to the hearings; and

WHEREAS, after hearing testimony and reviewing evidence, the hearing officer made findings and recommendations for adjudication concerning certain parcels as follows:

- 1) **Case #22-410: Parcel #628-376** located at 3043 Lakewood Dr.: No appearance by the owner or an interested party. The hearing officer recommends that the property be adjudicated as a menace to public health, safety, and welfare with an assessment of actual costs and a penalty of \$500.00 Ward 6

Scope of Work: Demolish and remove remains of the dilapidated structure, trash, debris, foundation, steps, driveway, tires, and any other items to ensure the property is clear and free of any and all health hazards and cut grass and weeds.

- 2) **Case #23-624: Parcel #306-127** located at 4313 Officer Thomas Catchings Dr.: No appearance by the owner or an interested party. The hearing officer recommends that the property be adjudicated as a menace to public health, safety, and welfare with an assessment of actual costs and a penalty of \$500.00 Ward 4

Scope of Work: Demolish and remove remains of the dilapidated structure, trash, debris, foundation, steps, driveway, tires, and any other items to ensure the property is clear and free of any and all health hazards and cut grass and weeds.

- 3) **Case #22-2523: Parcel #306-129** located at 4309 Officer Thomas Catchings Dr.: No appearance by the owner or an interested party. The hearing officer recommends that the

Consent Agenda No. 10
May 23, 2023
(Dotson, Lumumba)

property be adjudicated as a menace to public health, and safety with an assessment of actual costs and a penalty of \$500.00. Ward 4

Scope of Work: Demolish and remove remains of the dilapidated structure, trash, debris, foundation, steps, driveway, tires, and any other items to ensure the property is clear and free of any and all health hazards and cut grass and weeds.

- 4) **Case #22-2106: Parcel #144-282** located at 811 Deer Park St.: After hearing testimony from owner Joe Davis, the hearing officer recommends that the property be adjudicated as a menace to public health, safety, and welfare. However, Joe Davis shall be afforded sixty (60) days, or until June 5, 2023, to cure the violations by completing the scope of work. If there is a default and the City proceeds with cleaning, the hearing officer recommends an assessment of actual costs and a penalty of \$750.00 Ward 3

Scope of Work: Demolish and remove remains of the dilapidated structure, trash, debris, foundation, steps, driveway, tires, and any other items to ensure the property is clear and free of any and all health hazards and cut grass and weeds.

- 5) **Case #22-1949: Parcel #91-44** located at 817 Palmyra St.: After hearing testimony from owner James Warner, the hearing officer recommends that the property be adjudicated as a menace to public health, safety, and welfare. However, James Warner shall be afforded sixty (60) days, or until May 6, 2023, to cure the violations by completing the scope of work. If there is a default and the City proceeds with cleaning, the hearing officer recommends an assessment of actual costs and a penalty of \$750.00. Ward 3

Scope of Work: Remove trash and debris. Cut grass, weeds, shrubbery, fence line, bushes, and saplings as needed.

- 6) **Case #22-1860: Parcel #91-41** located at 841 Palmyra St.: After hearing testimony from owner James Warner, the hearing officer recommends that the property be adjudicated as a menace to public health, safety, and welfare. However, James Warner shall be afforded sixty (60) days, or until May 6, 2023, to cure the violations by completing the scope of work. If there is a default and the City proceeds with cleaning, the hearing officer recommends an assessment of actual costs and a penalty of \$750.00. Ward 3

Scope of Work: Remove trash and debris. Cut grass, weeds, shrubbery, fence line, bushes, and saplings as needed.

- 7) **Case #22-1199: Parcel #711-146** located at 6002 Whitestone Rd.: No appearance by the owner or an interested party. The hearing officer recommends that the property be adjudicated as a menace to public health, safety, and welfare with an assessment of actual costs and a penalty of \$500.00. Ward 2

Scope of Work: Demolish and remove remains of the dilapidated structure, trash, debris, foundation, steps, driveway, tires, and any other items to ensure the property is clear and free of any and all health hazards and cut grass and weeds.

IT IS HEREBY ORDERED that the above parcels be adjudicated a menace to public health as recommended by the hearing officer.

IT IS HEREBY ORDERED that a copy of the notices mailed and posted to owners and interested parties of the above parcels shall be included in the minutes along with this resolution pursuant to Section 21-19-11 of the Mississippi Code as amended.

IT IS HEREBY ORDERED that the Administration shall be authorized to remedy conditions on the parcels posing a threat to public, health, and safety using municipal resources or contract labor if the owners fail to do so.

IT IS HEREBY ORDERED that the adjudication of penalties, if any, shall be reserved until such time that a resolution is approved assessing actual costs.

ITEM# _____
AGENDA _____

CITY COUNCIL AGENDA ITEM 10 POINT DATA SHEET

03/21/2023
DATE

POINTS	COMMENTS																																													
1. Brief Description/Purpose	This is Community Improvement regular agenda for the City Council authority to clean private property.																																													
2. Public Policy Initiative 1. Youth & Education 2. Crime Prevention 3. Changes in City Government 4. Neighborhood Enhancement 5. Economic Development 6. Infrastructure and Transportation 7. Quality of Life	1. Neighborhood Enhancement 2. Crime Prevention 7. Quality of Life																																													
3. Who will be affected	All City of Jackson residents																																													
4. Benefits	The cleaning of the private properties will improve the conditions of communities and will also remove threats to the health, safety and welfare of surrounding residents.																																													
5. Schedule (beginning date)	To be determined pending execution of contracts.																																													
6. Location: ▪ WARD ▪ CITYWIDE (yes or no) (area) ▪ Project limits if applicable	CITYWIDE																																													
7. Action implemented by: City Department <input type="checkbox"/> ▪ Consultant <input type="checkbox"/>	PLANNING AND DEVELOPMENT DEPARTMENT COMMUNITY IMPROVEMENT DIVISION																																													
8. COST	To be determined pending execution of contracts.																																													
9. Source of Funding ▪ General Fund ▪ Grant <input type="checkbox"/> ▪ Bond <input type="checkbox"/> ▪ Other <input type="checkbox"/>	COMMUNITY IMPROVEMENT DEVELOPMENT BLOCK GRANT FUNDS GENERAL FUNDS																																													
10. EBO participation	<table border="0"> <tr> <td>ABE</td> <td>_____ %</td> <td>WAIVER</td> <td>yes</td> <td>_____</td> <td>no</td> <td>_____</td> <td>N/A</td> <td>_____</td> </tr> <tr> <td>AABE</td> <td>_____ %</td> <td>WAIVER</td> <td>yes</td> <td>_____</td> <td>no</td> <td>_____</td> <td>N/A</td> <td>_____</td> </tr> <tr> <td>WBE</td> <td>_____ %</td> <td>WAIVER</td> <td>yes</td> <td>_____</td> <td>no</td> <td>_____</td> <td>N/A</td> <td>_____</td> </tr> <tr> <td>HBE</td> <td>_____ %</td> <td>WAIVER</td> <td>yes</td> <td>_____</td> <td>no</td> <td>_____</td> <td>N/A</td> <td>_____</td> </tr> <tr> <td>NABE</td> <td>_____ %</td> <td>WAIVER</td> <td>yes</td> <td>_____</td> <td>no</td> <td>_____</td> <td>N/A</td> <td>_____</td> </tr> </table>	ABE	_____ %	WAIVER	yes	_____	no	_____	N/A	_____	AABE	_____ %	WAIVER	yes	_____	no	_____	N/A	_____	WBE	_____ %	WAIVER	yes	_____	no	_____	N/A	_____	HBE	_____ %	WAIVER	yes	_____	no	_____	N/A	_____	NABE	_____ %	WAIVER	yes	_____	no	_____	N/A	_____
ABE	_____ %	WAIVER	yes	_____	no	_____	N/A	_____																																						
AABE	_____ %	WAIVER	yes	_____	no	_____	N/A	_____																																						
WBE	_____ %	WAIVER	yes	_____	no	_____	N/A	_____																																						
HBE	_____ %	WAIVER	yes	_____	no	_____	N/A	_____																																						
NABE	_____ %	WAIVER	yes	_____	no	_____	N/A	_____																																						

Department of Planning and Development



200 South President Street
Post Office Box 17
Jackson, Mississippi 39205-0017

MEMORANDUM

TO: Mayor Choke A. Lumumba

VIA: Chloe Dotson
Director, Planning, and Development

FROM: Community Improvement
Planning and Development

DATE: 3/21/2023

RE: Agenda Item

The attached agenda item is a Resolution declaring a certain parcel of real property in the City of Jackson to be a menace to public health, safety, and welfare pursuant to section 21-19-11 of the Mississippi Code. Therefore, we request that you authorize cleaning.

Thank you for your consideration.

Office of the City Attorney

455 East Capitol Street
Post Office Box 2779
Jackson, Mississippi 39207-2779
Telephone: (601) 960-1799
Facsimile: (601) 960-1756

OFFICE OF THE CITY ATTORNEY

This RESOLUTION DECLARING CERTAIN PARCELS OF REAL PROPERTY IN THE CITY OF JACKSON TO BE A MENACE TO PUBLIC HEALTH, SAFETY, AND WELFARE PURSUANT TO SECTION 21-19-11 OF THE MISSISSIPPI CODE AND BASED ON ADMINISTRATIVE HEARINGS HELD MARCH 21, 2023 FOR THE FOLLOWING CASES: 22-410 23-624 22-2523 22-2106 22-1949 22-1860 22-1199 is legally sufficient for placement in NOVUS Agenda.



Catoria Martin, *City Attorney*

Kristie Metcalfe, *Deputy City Attorney* 

5/3/23
Date

OFFICE OF THE CITY ATTORNEY
5/3/23

11

OFFICE OF THE CITY CLERK
JACKSON, MISSISSIPPI
6/6/2023

RESOLUTION DECLARING CERTAIN PARCELS OF REAL PROPERTY IN THE CITY OF JACKSON TO BE A MENACE TO PUBLIC HEALTH, SAFETY, AND WELFARE PURSUANT TO SECTION 21-19-11 OF THE MISSISSIPPI CODE AND BASED ON ADMINISTRATIVE HEARINGS HELD ON FEBRUARY 28, 2023 FOR THE FOLLOWING CASES:

22-2427	22-721	21-372	21-612	22-2262	22-1955
22-835	22-116	21-925	21-773	22-1359	23-2
22-336	22-115	21-1216	21-580	21-1483	
22-282	22-670	22-247	21-385	23-180	
22-837	21-462	21-1498	21-671	22-800	

WHEREAS, Section 21-19-11 of the Mississippi Code, as amended, provides that a governing authority shall conduct a hearing to determine whether property or parcels of land located within a municipality is in such a state of uncleanness as to be a menace to the public health, safety, and welfare of the community; and

WHEREAS, Section 21-19-11 of the Mississippi Code as amended sets forth the procedure for mailing and posting notice of the hearing; and

WHEREAS, hearings were held on February 28, 2023; and

WHEREAS, the hearing officer determined that notice was provided in accordance with Section 21-19-11 prior to the hearings; and

WHEREAS, after hearing testimony and reviewing evidence, the hearing officer made findings and recommendations for adjudication concerning certain parcels as follows:

- 1) **Case #22-2427: Parcel #837-16** located at 2435 Vernon Dr.: No appearance by owner or an interested party. Hearing officer recommends that the property be adjudicated as a menace to public health, safety, and welfare with assessment of actual costs and a penalty of \$750.00. Ward 5

Scope of Work: Cut grass, weeds, shrubbery, fence line, bushes, saplings as needed. Remove trash and debris. Remove inoperable vehicle(s) or vehicle(s) parked on grass.

- 2) **Case #22-835: Parcel #837-14** located at 2464 Vernon Dr.: No appearance by owner or an interested party. Hearing officer recommends that the property be adjudicated as a menace to public health, safety, and welfare with assessment of actual costs. Ward 5

Scope of Work: Demolish and remove remains of dilapidated structure, trash, debris, foundation, steps, driveway, tires, and any other items to insure property is clear and free

of any and all health hazards. Cut grass, weeds, shrubbery, fence line, bushes, saplings as needed.

- 3) **Case #22-336: Parcel #837-11** located at 2434 Vernon Dr.: No appearance by owner or an interested party. Hearing officer recommends that the property be adjudicated as a menace to public health, safety, and welfare with assessment of actual costs. Ward 5

Scope of Work: Demolish and remove remains of dilapidated structure, trash, debris, foundation, steps, driveway, tires, and any other items to insure property is clear and free of any and all health hazards. Cut grass, weeds, shrubbery, fence line, bushes, saplings as needed.

- 4) **Case #22-282: Parcel #837-13** located at 2454 Vernon Dr.: No appearance by owner or an interested party. Hearing officer recommends that the property be adjudicated as a menace to public health, safety, and welfare with assessment of actual costs and a penalty of \$500.00. Ward 5

Scope of Work: Demolish and remove remains of dilapidated structure, trash, debris, foundation, steps, driveway, tires, and any other items to insure property is clear and free of any and all health hazards. Cut grass, weeds, shrubbery, fence line, bushes, saplings as needed.

- 5) **Case #22-837: Parcel #837-146** located at 2346 Hickory Dr.: No appearance by owner or an interested party. Hearing officer recommends that the property be adjudicated as a menace to public health, safety, and welfare with assessment of actual costs. Ward 5

Scope of Work: Demolish and remove remains of dilapidated structure, trash, debris, foundation, steps, driveway, tires, and any other items to insure property is clear and free of any and all health hazards. Cut grass, weeds, shrubbery, fence line, bushes, saplings as needed

- 6) **Case # 22-721: Parcel #837-178-1** located at 2269 Hickory Dr.: No appearance by owner or an interested party. Hearing officer recommends that the property be adjudicated as a menace to public health, safety, and welfare with assessment of actual costs. Ward 5

Scope of Work: Demolish and remove remains of dilapidated structure, trash, debris, foundation, steps, driveway, tires, and any other items to insure property is clear and free of any and all health hazards. Cut grass, weeds, shrubbery, fence line, bushes, saplings as needed.

- 7) **Case #22-116: Parcel #837-166-2** located at 2343 Hickory Dr.: No appearance by owner or an interested party. Hearing officer recommends that the property be adjudicated as a menace to public health, safety, and welfare with assessment of actual costs and a penalty of \$750.00. Ward 5

Scope of Work: Demolish and remove remains of dilapidated structure, trash, debris, foundation, steps, driveway, tires, and any other items to insure property is clear and free of any and all health hazards. Cut grass, weeds, shrubbery, fence line, bushes, saplings as needed.

- 8) **Case #22-115: Parcel #837-147** located at 2356 Hickory Dr.: No appearance by owner or an interested party. Hearing officer recommends that the property be adjudicated as a menace to public health, safety, and welfare with assessment of actual costs and a penalty of \$750.00. Ward 5

Scope of Work: Demolish and remove remains of dilapidated structure, trash, debris, foundation, steps, driveway, tires, and any other items to insure property is clear and free of any and all health hazards. Cut grass, weeds, shrubbery, fence line, bushes, saplings as needed.

- 9) **Case #22-670: Parcel #837-120** located at 2306 Hickory Dr.: After hearing testimony from owner Melinda S. McNamee, hearing officer recommends that the property be adjudicated as a menace to public health, safety, and welfare; however, Melinda S. McNamee shall be afforded thirty (30) days until March 30, 2023 to cure the violations by completing the scope of work. If there is a default and the City proceeds with cleaning, hearing officer recommends an assessment of actual costs and a penalty of \$1,000.00. Ward 5

Scope of Work: Cut grass, weeds, shrubbery, fence line, bushes, saplings as needed. Remove trash and debris. Remove inoperable vehicle(s) or vehicle(s) parked on grass.

- 10) **Case #21-462: Parcel #95-184** located at 158 Clover Leaf Cir.: No appearance by owner or an interested party. Hearing officer recommends that the property be adjudicated as a menace to public health, safety, and welfare with assessment of actual costs and a penalty of \$500.00. Ward 3

Scope of Work: Remove trash and debris.

- 11) **Case #21-372: Parcel #101-38** located at 2924 Marion Dunbar St.: No appearance by owner or an interested party. Hearing officer recommends that the property be adjudicated as a menace to public health, safety, and welfare with assessment of actual costs and a penalty of \$500.00. Ward 3

Scope of Work: Demolish and remove remains of dilapidated structure, trash, debris, foundation, steps, driveway, tires, and any other items to insure property is clear and free of any and all health hazards. Cut grass, weeds, shrubbery, fence line, bushes, saplings as needed.

- 12) **Case #21-925: Parcel #410-445** located at 0 Skyline Dr.: No appearance by owner or an interested party. Hearing officer recommends that the property be adjudicated as a menace to public health, safety, and welfare. Ward 5

Scope of Work: Cut grass, weeds, shrubbery, fence line, bushes, saplings as needed. Remove trash and debris.

- 13) **Case #21-1216: Parcel #105-182-5** located at 524 Scott St.: No appearance by owner or an interested party. Hearing officer recommends that the property be adjudicated as a menace to public health, safety, and welfare with assessment of actual costs and a penalty of \$1,000.00. Ward 5

Scope of Work: Demolish and remove remains of dilapidated structure, trash, debris, foundation, steps, driveway, tires, and any other items to insure property is clear and free of any and all health hazards. Cut grass, weeds, shrubbery, fence line, bushes, saplings as needed.

- 14) **Case #22-247: Parcel #802-171** located at 134 James Monroe Pl.: No appearance by owner or an interested party. Hearing officer recommends that the property be adjudicated as a menace to public health, safety, and welfare with assessment of actual costs and a penalty of \$750.00. Ward 3

Scope of Work: Demolish and remove remains of dilapidated structure, trash, debris, foundation, steps, driveway, tires, and any other items to insure property is clear and free of any and all health hazards. Cut grass, weeds, shrubbery, fence line, bushes, saplings as needed.

- 15) **Case #21-1498: Parcel #410-95** located at 3618 Cromwell St.: No appearance by owner or an interested party. Hearing officer recommends that the property be adjudicated as a menace to public health, safety, and welfare with assessment of actual costs and a penalty of \$750.00. Ward 3

Scope of Work: Remove trash and debris. Remove inoperable vehicle(s) or vehicle(s) parked on grass.

- 16) **Case #21-612: Parcel #523-504** located at 4639 Locksley Dr.: No appearance by owner or an interested party. Hearing officer recommends that the property be adjudicated as a menace to public health, safety, and welfare with assessment of actual costs and a penalty of \$750.00. Ward 2

Scope of Work: Cut grass, weeds, shrubbery, fence line, bushes, and saplings as needed. Remove trash and debris.

- 17) **Case #21-773: Parcel #712-232** located at 5961 Huntview Dr.: After hearing testimony from owner Ron Myer, hearing officer recommends that the property be adjudicated as a menace to public health, safety, and welfare; however, Ron Myer shall be afforded sixty (60) days until April 29, 2023 to cure the violations by completing the scope of work. If there is a default and the City proceeds with cleaning, hearing officer recommends an assessment of actual costs and a penalty of \$500.00. Ward 2

Scope of Work: Demolish and remove remains of dilapidated structure, trash, debris, foundation, steps, driveway, tires, and any other items to insure property is clear and free of any and all health hazards. Cut grass, weeds, shrubbery, fence line, bushes, saplings as needed.

- 18) **Case #21-580: Parcel #642-164** located at 5354 Queen Mary Ln.: No appearance by owner or an interested party. Hearing officer recommends that the property be adjudicated as a menace to public health, safety, and welfare with assessment of actual costs and a penalty of \$750.00. Ward 4

Scope of Work: Board up and/or secure structure(s). Cut grass, weeds, shrubbery, fence line, bushes, saplings as needed. Remove trash and debris.

- 19) **Case #21-385: Parcel #431-219** located at 769 Woodbury Rd.: No appearance by owner or an interested party. Hearing officer recommends that the property be adjudicated as a menace to public health, safety, and welfare with assessment of actual costs and a penalty of \$1,500.00. Ward 3

Scope of Work: Remove trash and debris. Remove inoperable vehicle(s) or vehicle(s) parked on grass.

- 20) **Case #21-671: Parcel #431-220** located at 763 Woodbury Rd.: No appearance by owner or an interested party. Hearing officer recommends that the property be adjudicated as a menace to public health, safety, and welfare with assessment of actual costs and a penalty of \$1,000.00. Ward 3

Scope of Work: Remove trash and debris.

- 21) **Case #22-2262: Parcel #517-658** located at 750 Woodbury Rd.: No appearance by owner or an interested party. Hearing officer recommends that the property be adjudicated as a menace to public health, safety, and welfare with assessment of actual costs and a penalty of \$750.00. Ward 3

Scope of Work: Cut grass, weeds, shrubbery, fence line, bushes, saplings as needed. Remove trash and debris. Remove inoperable vehicle(s) or vehicle(s) parked on grass.

- 22) **Case #22-1359: Parcel #433-157** located at 4616 Normandy Dr.: No appearance by owner or an interested party. Hearing officer recommends that the property be adjudicated as a menace to public health, safety, and welfare with assessment of actual costs and a penalty of \$750.00. Ward 3

Scope of Work: Cut grass, weeds, shrubbery, fence line, bushes, saplings as needed. Remove trash and debris. Remove inoperable vehicle(s) or vehicle(s) parked on grass.

- 23) **Case #21-1483: Parcel #19-74** located at 1211 Kenwood Pl. Unit AB.: No appearance by owner or an interested party. Hearing officer recommends that the property be adjudicated as a menace to public health, safety, and welfare with assessment of actual costs and a penalty of \$750.00. Ward 7

Scope of Work: Cut grass, weeds, shrubbery, fence line, bushes, saplings as needed. Remove trash and debris. Remove inoperable vehicle(s) or vehicle(s) parked on grass.

- 24) **Case #23-180: Parcel #72-70** located at 141 E. Davis St.: No appearance by owner or an interested party. Hearing officer recommends that the property be adjudicated as a menace to public health, safety, and welfare with assessment of actual costs and a penalty of \$500.00. Ward 7

Scope of Work: Board up and/or secure structure(s). Cut grass, weeds, shrubbery, fence line, bushes, saplings as needed. Remove trash and debris.

- 25) **Case #22-800: Parcel #51-143** located at 504 Mitchell Ave.: No appearance by owner or an interested party. Hearing officer recommends that the property be adjudicated as a menace to public health, safety, and welfare with assessment of actual costs and a penalty of \$500.00. Ward 7

Scope of Work: Board up and/or secure structure(s). Cut grass, weeds, shrubbery, fence line, bushes, saplings as needed. Remove trash and debris.

- 26) **Case #22-1955: Parcel #517-656** located at 756 Woodbury Rd.: After hearing testimony from owner Portia Taylor, hearing officer recommends that the property be adjudicated as a menace to public health, safety, and welfare; however, Portia Taylor shall be afforded thirty (30) days until March 30, 2023 to cure the violations by completing the scope of work. If there is a default and the City proceeds with cleaning, hearing officer recommends an assessment of actual costs and a penalty of \$500.00. Ward 3

Scope of Work: Remove trash and debris. Remove inoperable vehicle(s) or vehicle(s) parked on grass.

- 27) **Case #23-2: Parcel #118-11** located at 120 Beach St.: No appearance by owner or an interested party. Hearing officer recommends that the property be adjudicated as a menace to public health, safety, and welfare with assessment of actual costs and a penalty of \$500.00. Ward 3

Scope of Work: Board up and/or secure structure(s). Cut grass, weeds, shrubbery, fence line, bushes, saplings as needed. Remove trash and debris.

IT IS HEREBY ORDERED that the above parcels be adjudicated a menace to public health, safety, and welfare as recommended by the hearing officer.

IT IS HEREBY ORDERED that a copy of the notices mailed and posted to owners and interested parties of the above parcels shall be included in the minutes along with this resolution pursuant to Section 21-19-11 of the Mississippi Code as amended.

IT IS HEREBY ORDERED that the Administration shall be authorized to remedy conditions on the parcels posing a threat to public health and safety using municipal resources or contract labor if the owners fail to do so.

IT IS HEREBY ORDERED that the adjudication of penalties, if any, shall be reserved until such time that a resolution is approved assessing actual costs.

ITEM# _____

AGENDA _____

CITY COUNCIL AGENDA ITEM 10 POINT DATA SHEET

3/3/2023

DATE

POINTS		COMMENTS
1.	Brief Description/Purpose	This is Community Improvement regular agenda item for the City Council authority to clean private property.
2.	Public Policy Initiative <ol style="list-style-type: none"> 1. Youth & Education 2. Crime Prevention 3. Changes in City Government 4. Neighborhood Enhancement 5. Economic Development 6. Infrastructure and Transportation 7. Quality of Life 	<ol style="list-style-type: none"> 1. Neighborhood Enhancement 2. Crime Prevention 7. Quality of Life
3.	Who will be affected	All City of Jackson residents
4.	Benefits	The cleaning of the private properties will improve the conditions of communities and will also remove threats to the health, safety and welfare of surrounding residents.
5.	Schedule (beginning date)	To be determined pending execution of contracts.
6.	Location: <ul style="list-style-type: none"> ▪ WARD ▪ CITYWIDE (yes or no) (area) ▪ Project limits if applicable 	CITYWIDE
7.	Action implemented by: <ul style="list-style-type: none"> ▪ City Department <input type="checkbox"/> ▪ Consultant <input type="checkbox"/> 	PLANNING AND DEVELOPMENT DEPARTMENT COMMUNITY IMPROVEMENT DIVISION
8.	COST	To be determined pending execution of contracts.
9.	Source of Funding <ul style="list-style-type: none"> ▪ General Fund <input type="checkbox"/> ▪ Grant <input type="checkbox"/> ▪ Bond <input type="checkbox"/> ▪ Other <input type="checkbox"/> 	GENERAL FUNDING
10.	EBO participation	ABE _____% WAIVER yes ___ no ___ N/A _____ AABE _____% WAIVER yes ___ no ___ N/A _____ WBE _____% WAIVER yes ___ no ___ N/A _____ HBE _____% WAIVER yes ___ no ___ N/A _____ NABE _____% WAIVER yes ___ no ___ N/A _____

Jackson Police Department
Community Improvement Unit



327 East Pascagoula Street
Post Office Box 17
Jackson, Mississippi 39205-0017

MEMORANDUM

TO: Mayor Choke A. Lumumba

Via: Chloe Dotson
Director, Planning and Development *Cum*

From: Community Improvement
Planning and Development

DATE: March 3, 2023

Re: Agenda Item

The attached agenda item is a Resolution declaring certain parcel of real property in the City of Jackson to be a menace to public health, safety, and welfare pursuant to section 21-19-11 of Mississippi Code. Therefore, we request that you authorize cleaning.

Thank you for your consideration.

Office of the City Attorney

455 East Capitol Street
Post Office Box 2779
Jackson, Mississippi 39207-2779
Telephone: (601) 960-1799
Facsimile: (601) 960-1756

OFFICE OF THE CITY ATTORNEY

This RESOLUTION DECLARING CERTAIN PARCELS OF REAL PROPERTY IN THE CITY OF JACKSON TO BE A MENACE TO PUBLIC HEALTH, SAFETY, AND WELFARE PURSUANT TO SECTION 21-19-11 OF THE MISSISSIPPI CODE AND BASED ON ADMINISTRATIVE HEARINGS HELD FEBRUARY 28, 2023 FOR THE FOLLOWING CASES: 22-2427 22-721 21-372 21-612 22-2262 22-1955 22-835 22-116 21-925 21-773 22-1359 23-2 22-336 22-115 21-1216 21-580 21-1483 22-282 22-670 22-247 21-385 23-180 22-837 21-462 21-1498 21-671 22-800 is legally sufficient for placement in NOVUS Agenda.



Catoria Martin, City Attorney

Kristie Metcalfe, Deputy City Attorney 

5/3/23

Date

OFFICE OF THE CITY ATTORNEY
5/2/23

12

OFFICE OF THE CITY ATTORNEY
4/10/23

ORDER AUTHORIZING THE MAYOR TO EXECUTE A CONTRACT BETWEEN THE CITY OF JACKSON AND TRIARC MANAGEMENT SERVICES LLC TO DEMOLISH A STRUCTURE, FOUNDATION, STEPS AND DRIVEWAY, TO CUT GRASS AND WEEDS, TO REMOVE TRASH AND DEBRIS, AND TO PERFORM OTHER WORK TO REMEDY THE CONDITIONS ON STATE-OWNED PROPERTY THAT CONSTITUTE A MENACE TO PUBLIC HEALTH, SAFETY, AND WELFARE ACCORDING TO MISSISSIPPI CODE ANNOTATED SECTION 21-19-11 FOR CASE #CE-22-1521 LOCATED AT 245 ARCHER AVE. PARCEL #613-230- \$5,000.00. (WARD 7) (DOTSON)

WHEREAS, the State of Mississippi received 245 Archer Ave. due to delinquent taxes;
and

WHEREAS, said property must be maintained and conditions that constitute a menace to public health, safety and welfare remedied; and

WHEREAS, on November 17, 2022, the State of Mississippi Public Lands Division issued a Consent to Enter onto State-Owned Property to the City for the purpose of cleaning and demolishing the improvement on the property at no cost to the Office of the Mississippi Secretary of State for case #CE-22-1521 located at 245 Archer Ave., parcel #613-230, in Ward 7 of the City of Jackson; and

WHEREAS, the Community Improvement Division of the Department of Planning and Development has a system in which vendors performing services related to the remedying of conditions on property deemed to be a menace to public health, safety, and welfare submit bids; and

WHEREAS, TriArc Management Services, LLC submitted the lowest bid and through its Member, Stacey Stowers, agreed to demolish the structure, foundation, steps, and driveway, to cut grass and weeds, to remove trash and debris, and to perform other work to remedy conditions constituting a menace to public health, safety, and welfare on the parcel located at 245 Archer Ave. for the sum of \$5,000.00; and

WHEREAS, TriArc Management Services, LLC, has a principal office address of 644 E. Rhinewalt Rd. Lena, MS 39094 according to the information appearing on the Mississippi Secretary of State's website; and

IT IS THEREFORE ORDERED that the Mayor be authorized to execute a contract with TriArc Management Services, LLC to demolish the structure, foundation, steps, and driveway, to cut grass and weeds, to remove trash and debris, and to perform work to remedy the other conditions on the property located at 245 Archer Ave. deemed to be a menace to public health, safety, and welfare;

IT IS FURTHER HEREBY ORDERED that a sum not to exceed \$5,000.00 shall be paid to TriArc Management Services, LLC for the services provided from funds budgeted for the Division.

Consent Agenda No.
May 23, 2023
(Dotson, Lumumba)

12

CITY COUNCIL AGENDA ITEM 10 POINT DATA SHEET

04/18/2023
DATE

POINTS		COMMENTS					
1.	Brief Description/Purpose	This item provides for the remedying of conditions for case adjudicated a menace by the City Council. The Order is asking that the Mayor be authorized to execute a contract for the completion of work to improve public health, safety and welfare.					
2.	Public Policy Initiative 1. Youth & Education 2. Crime Prevention 3. Changes in City Government 4. Neighborhood Enhancement 5. Economic Development 6. Infrastructure and Transportation 7. Quality of Life	1. Neighborhood Enhancement 2. Crime Prevention 7. Quality of Life					
3.	Who will be affected	All City of Jackson residents.					
4.	Benefits	Cleaning of the private property will remove threats to the health, safety and welfare of surrounding residents while improving the condition of the community.					
5.	Schedule (beginning date)	To be determined pending execution of contract.					
	Location: ▪ WARD ▪ CITYWIDE (yes or no) (area) ▪ Project limits if applicable	Ward 7					
7.	Action implemented by: ▪ City Department <input type="checkbox"/> ▪ Consultant <input type="checkbox"/>	PLANNING AND DEVELOPMENT DEPARTMENT COMMUNITY IMPROVEMENT DIVISION					
8.	COST	\$5,000.00					
9.	Source of Funding ▪ General Fund ▪ Grant <input type="checkbox"/> ▪ Bond <input type="checkbox"/> ▪ Other <input type="checkbox"/>	General Funding (001-444-70-6485)					
10.	EBO participation	ABE	%	WAIVER	yes	no	N/A
		AABE	%	WAIVER	yes	no	N/A
		WBE	%	WAIVER	yes	no	N/A
		HBE	%	WAIVER	yes	no	N/A
		NABE	%	WAIVER	yes	no	N/A



Memo

To: Chokwe Lumumba, Mayor

From: Chloe Dotson, Director
Department of Planning and Development

Date: 4/18/2023

Re: Agenda Item

The attached agenda item is an Order requesting that the Mayor execute a contract with TriArc Management Services LLC for to demolish the structure, foundation, steps, and driveway; cut grass and weeds; remove trash and debris for certain parcels of real property in the City of Jackson declared to be a menace to public health, safety and welfare pursuant to Section 21-19-11 of Mississippi Code.

Therefore, we respectfully request that you authorize the execution of contract and related documents for project selected and awarded to the said contractor for the following case #CE-22-1521.

Thank you for your prompt consideration in this matter.

Office of the City Attorney

455 East Capitol Street
Post Office Box 2779
Jackson, Mississippi 39207-2779
Telephone: (601) 960-1799
Facsimile: (601) 960-1756

OFFICE OF THE CITY ATTORNEY

3

This ORDER AUTHORIZING THE MAYOR TO EXECUTE A CONTRACT BETWEEN THE CITY OF JACKSON AND TRIARC MANAGEMENT SERVICES LLC TO DEMOLISH A STRUCTURE, FOUNDATION, STEPS AND DRIVEWAY, TO CUT GRASS AND WEEDS, TO REMOVE TRASH AND DEBRIS, AND TO PERFORM OTHER WORK TO REMEDY THE CONDITIONS ON STATE-OWNED PROPERTY THAT CONSTITUTE A MENACE TO PUBLIC HEALTH, SAFETY, AND WELFARE ACCORDING TO MISSISSIPPI CODE ANNOTATED SECTION 21-19-11 FOR CASE #CE-22-1521 LOCATED AT 245 ARCHER AVE. PARCEL #613-230 \$5,000.00 is legally sufficient for placement in NOVUS Agenda.

Catoria Martin, City Attorney

Kristie Metcalfe, Deputy City Attorney 

4/28/23
Date

13

ORDER AUTHORIZING THE MAYOR TO EXECUTE A CONTRACT BETWEEN THE CITY OF JACKSON AND R & C SERVICES, LLC. TO DEMOLISH THE STRUCTURE, FOUNDATION, STEPS, AND DRIVEWAY; CUT GRASS AND WEEDS; REMOVE TRASH AND DEBRIS; AND REMEDY CONDITIONS ON PRIVATE PROPERTY WHICH CONSTITUTE A MENACE TO PUBLIC HEALTH, SAFETY, AND WELFARE ACCORDING TO MISSISSIPPI CODE ANNOTATED SECTION 21-19-11 FOR CASE #CE-21-685 LOCATED AT 1804 BAILEY AVE. PARCEL #98-129 – \$4,750.00 – WARD 7

OFFICE OF THE CITY CLERK
5/24/23

WHEREAS, on September 13, 2022, the Jackson City Council approved a resolution declaring certain parcels of real property in the City of Jackson to be a menace to public health, safety, and welfare pursuant to Section 21-19-11 of the Mississippi Code following an administrative hearing held on August 9, 2022, for case #CE-21-685 located at 1804 Bailey Ave., parcel #98-129, in Ward 7 of the City of Jackson; and

WHEREAS, the Community Improvement Division of the Planning and Development Department maintains a list of licensed, bonded, and insured contractors that received and responded to the request for bids for the demolition project located at 1804 Bailey Ave.; and

WHEREAS, R & C Services, LLC submitted the lowest bid of \$4,750.00; and

WHEREAS, a municipal contract for the professional services of a contractor is not subject to advertising and bidding requirements set forth in Section 31-7-13 of the Mississippi Code of 1972; and

WHEREAS, upon receipt of a written Notice to Proceed, R & C Services, LLC through its representative, Raymond Granderson has agreed to demolish the structure, foundation, steps, driveway and/or cut grass, weeds, shrubbery, fence line, bushes, and saplings; remove trash, debris, tires, crates, appliances, building materials, furniture, and fallen tree parts; clean curbside; and remedy conditions constituting a menace to public health, safety, and welfare for the parcel located at 1804 Bailey Ave. in an amount not to exceed \$4,750.00; and

WHEREAS, R & C Services, LLC has a principal office located at 987 Gore Rd., Jackson, MS 39212, according to the information appearing on the Mississippi Secretary of State's website.

IT IS, THEREFORE, ORDERED that the Mayor is authorized to execute a contract with R & C Services, LLC to demolish the structure and remedy conditions on the property located at 1804 Bailey Ave. deemed to be a menace to public health, safety, and welfare.

IT IS FURTHER HEREBY ORDERED that a sum not to exceed \$4,750.00 shall be paid to R & C Services, LLC upon the completion of the services provided from funds budgeted for the Division.

CITY COUNCIL AGENDA ITEM 10 POINT DATA SHEET

04/18/2023
DATE

POINTS		COMMENTS			
1.	Brief Description/Purpose	This item provides for the remedying of conditions for case adjudicated a menace by the City Council. The Order is asking that the Mayor be authorized to execute a contract for the completion of work to improve public health, safety and welfare.			
2.	Public Policy Initiative 1. Youth & Education 2. Crime Prevention 3. Changes in City Government 4. Neighborhood Enhancement 5. Economic Development 6. Infrastructure and Transportation 7. Quality of Life	1. Neighborhood Enhancement 2. Crime Prevention 7. Quality of Life			
3.	Who will be affected	All City of Jackson residents.			
4.	Benefits	Cleaning of the private property will remove threats to the health, safety and welfare of surrounding residents while improving the condition of the community.			
5.	Schedule (beginning date)	To be determined pending execution of contract.			
6.	Location: ▪ WARD ▪ CITYWIDE (yes or no) (area) ▪ Project limits if applicable	Ward 7			
7.	Action implemented by: ▪ City Department <input type="checkbox"/> ▪ Consultant <input type="checkbox"/>	PLANNING AND DEVELOPMENT DEPARTMENT COMMUNITY IMPROVEMENT DIVISION			
8.	COST	\$4,750.00			
9.	Source of Funding ▪ General Fund ▪ Grant <input type="checkbox"/> ▪ Bond <input type="checkbox"/> ▪ Other <input type="checkbox"/>	General Funding (001-444-70-6485)			
10.	EBO participation	ABE _____ % AABE _____ % WBE _____ % HBE _____ % NABE _____ %	WAIVER yes _____ no _____ WAIVER yes _____ no _____ WAIVER yes _____ no _____ WAIVER yes _____ no _____ WAIVER yes _____ no _____	N/A _____ N/A _____ N/A _____ N/A _____ N/A _____	



Memo

To: Chokwe Lumumba, Mayor

From: Chloe Dotson, Director
Department of Planning and Development

Date: 4/18/2023

Re: Agenda Item

The attached agenda item is an Order requesting that the Mayor execute a contract with R & C Services, LLC., for to demolish the structure, foundation, steps, and driveway; cut grass and weeds; remove trash and debris for certain parcels of real property in the City of Jackson declared to be a menace to public health, safety and welfare pursuant to Section 21-19-11 of Mississippi Code.

Therefore, we respectfully request that you authorize the execution of contract and related documents for project selected and awarded to the said contractor for the following case #CE-21-685.

Thank you for your prompt consideration in this matter.

Office of the City Attorney

455 East Capitol Street
Post Office Box 2779
Jackson, Mississippi 39207-2779
Telephone: (601) 960-1799
Facsimile: (601) 960-1756

OFFICE OF THE CITY ATTORNEY

This **ORDER AUTHORIZING THE MAYOR TO EXECUTE A CONTRACT BETWEEN THE CITY OF JACKSON AND R & C SERVICES, LLC. TO DEMOLISH THE STRUCTURE, FOUNDATION, STEPS, AND DRIVEWAY; CUT GRASS AND WEEDS; REMOVE TRASH AND DEBRIS; AND REMEDY CONDITIONS ON PRIVATE PROPERTY WHICH CONSTITUTE A MENACE TO PUBLIC HEALTH, SAFETY, AND WELFARE ACCORDING TO MISSISSIPPI CODE ANNOTATED SECTION 21-19-11 FOR CASE #CE--21-685 LOCATED AT 1804 BAILEY AVE. PARCEL #98-129- \$4,750.00** is legally sufficient for placement in NOVUS Agenda.



Catoria Martin, City Attorney

Kristie Metcalfe, Deputy City Attorney 

5 / 3 / 23

Date

14

ORDER AUTHORIZING THE MAYOR TO EXECUTE A CONTRACT BETWEEN THE CITY OF JACKSON AND R & C SERVICES, LLC. TO DEMOLISH THE STRUCTURE, FOUNDATION, STEPS, AND DRIVEWAY; CUT GRASS AND WEEDS; REMOVE TRASH AND DEBRIS; AND REMEDY CONDITIONS ON PRIVATE PROPERTY WHICH CONSTITUTE A MENACE TO PUBLIC HEALTH, SAFETY, AND WELFARE ACCORDING TO MISSISSIPPI CODE ANNOTATED SECTION 21-19-11 FOR CASE #CE-21-1563 LOCATED AT 946 N. CONGRESS ST. PARCEL #39-56- \$8,600.00 – WARD 7

OFFICE OF THE CITY CLERK
6/9/23

WHEREAS, on August 2, 2022, the Jackson City Council approved a resolution declaring certain parcels of real property in the City of Jackson to be a menace to public health, safety, and welfare pursuant to Section 21-19-11 of the Mississippi Code following an administrative hearing held on July 12, 2022, for case #CE-21-1563 located at 946 N. Congress St., parcel #39-56, in Ward 7 of the City of Jackson; and

WHEREAS, the Community Improvement Division of the Planning and Development Department maintains a list of licensed, bonded, and insured contractors that received and responded to the request for bids for the demolition project located at 946 N. Congress St.; and

WHEREAS, R & C Services, LLC submitted the lowest bid of \$8,600.00; and

WHEREAS, a municipal contract for the professional services of a contractor is not subject to advertising and bidding requirements set forth in Section 31-7-13 of the Mississippi Code of 1972; and

WHEREAS, upon receipt of a written Notice to Proceed, R & C Services, LLC through its representative, Raymond Granderson has agreed to demolish the structure, foundation, steps, driveway and/or cut grass, weeds, shrubbery, fence line, bushes, and saplings; remove trash, debris, tires, crates, appliances, building materials, furniture, and fallen tree parts; clean curbside; and remedy conditions constituting a menace to public health, safety, and welfare for the parcel located at 946 N. Congress St. in an amount not to exceed \$8,600.00; and

WHEREAS, R & C Services, LLC has a principal office located at 987 Gore Rd., Jackson, MS 39212, according to the information appearing on the Mississippi Secretary of State's website.

IT IS, THEREFORE, ORDERED that the Mayor is authorized to execute a contract with R & C Services, LLC to demolish the structure and remedy conditions on the property located at 946 N. Congress St. deemed to be a menace to public health, safety, and welfare.

IT IS FURTHER HEREBY ORDERED that a sum not to exceed \$8,600.00 shall be paid to R & C Services, LLC upon the completion of the services provided from funds budgeted for the Division.

CITY COUNCIL AGENDA ITEM 10 POINT DATA SHEET

04/18/2023
DATE

POINTS		COMMENTS						
1.	Brief Description/Purpose	This item provides for the remedying of conditions for case adjudicated a menace by the City Council. The Order is asking that the Mayor be authorized to execute a contract for the completion of work to improve public health, safety and welfare.						
2.	Public Policy Initiative 1. Youth & Education 2. Crime Prevention 3. Changes in City Government 4. Neighborhood Enhancement 5. Economic Development 6. Infrastructure and Transportation 7. Quality of Life	1. Neighborhood Enhancement 2. Crime Prevention 7. Quality of Life						
3.	Who will be affected	All City of Jackson residents.						
4.	Benefits	Cleaning of the private property will remove threats to the health, safety and welfare of surrounding residents while improving the condition of the community.						
5.	Schedule (beginning date)	To be determined pending execution of contract.						
6.	Location: ■ WARD ■ CITYWIDE (yes or no) (area) ■ Project limits if applicable	Ward 7						
7.	Action implemented by: ■ City Department <input type="checkbox"/> ■ Consultant <input type="checkbox"/>	PLANNING AND DEVELOPMENT DEPARTMENT COMMUNITY IMPROVEMENT DIVISION						
8.	COST	\$8,600.00						
9.	Source of Funding ■ General Fund ■ Grant <input type="checkbox"/> ■ Bond <input type="checkbox"/> ■ Other <input type="checkbox"/>	General Funding (001-444-70-6485)						
10.	EBO participation	ABE	_____ %	WAIVER	yes _____	no _____	N/A _____	
		AABE	_____ %	WAIVER	yes _____	no _____	N/A _____	
		WBE	_____ %	WAIVER	yes _____	no _____	N/A _____	
		HBE	_____ %	WAIVER	yes _____	no _____	N/A _____	
		NABE	_____ %	WAIVER	yes _____	no _____	N/A _____	



Memo

To: Chokwe Lumumba, Mayor

From: Chloe Dotson, Director
Department of Planning and Development

Date: 4/18/2023

Re: Agenda Item

The attached agenda item is an Order requesting that the Mayor execute a contract with R & C Services, LLC., for to demolish the structure, foundation, steps, and driveway; cut grass and weeds; remove trash and debris for certain parcels of real property in the City of Jackson declared to be a menace to public health, safety and welfare pursuant to Section 21-19-11 of Mississippi Code.

Therefore, we respectfully request that you authorize the execution of contract and related documents for project selected and awarded to the said contractor for the following case #CE-21-1563.

Thank you for your prompt consideration in this matter.

Office of the City Attorney

455 East Capitol Street
Post Office Box 2779
Jackson, Mississippi 39207-2779
Telephone: (601) 960-1799
Facsimile: (601) 960-1756

OFFICE OF THE CITY ATTORNEY

This ORDER AUTHORIZING THE MAYOR TO EXECUTE A CONTRACT BETWEEN THE CITY OF JACKSON AND R & C SERVICES, LLC. TO DEMOLISH THE STRUCTURE, FOUNDATION, STEPS, AND DRIVEWAY; CUT GRASS AND WEEDS; REMOVE TRASH AND DEBRIS; AND REMEDY CONDITIONS ON PRIVATE PROPERTY WHICH CONSTITUTE A MENACE TO PUBLIC HEALTH, SAFETY, AND WELFARE ACCORDING TO MISSISSIPPI CODE ANNOTATED SECTION 21-19-11 FOR CASE #CE-22-1563 LOCATED AT 946 N. CONGRESS ST. PARCEL #39-56-\$8,600.00 is legally sufficient for placement in NOVUS Agenda.

Catoria Martin, City Attorney

Kristie Metcalfe, Deputy City Attorney 

5/3/23
Date

OFFICE OF THE CITY ATTORNEY
5/2/23

15

OFFICE OF THE SECRETARY OF STATE
APL
5/23/23

ORDER AUTHORIZING THE MAYOR TO EXECUTE A CONTRACT BETWEEN THE CITY OF JACKSON AND LOVE TRUCKING CO., INC. TO DEMOLISH A STRUCTURE, FOUNDATION, STEPS AND DRIVEWAY, TO CUT GRASS AND WEEDS, TO REMOVE TRASH AND DEBRIS, AND TO PERFORM OTHER WORK TO REMEDY THE CONDITIONS ON STATE-OWNED PROPERTY THAT CONSTITUTE A MENACE TO PUBLIC HEALTH, SAFETY, AND WELFARE ACCORDING TO MISSISSIPPI CODE ANNOTATED SECTION 21-19-11 FOR CASE #CE-22-144 LOCATED AT 151 WOODY DR. PARCEL #625-38-2- \$6,400.00. (WARD 7) (DOTSON)

WHEREAS, the State of Mississippi received 151 Woody Dr. due to delinquent taxes; and

WHEREAS, said property must be maintained and conditions that constitute a menace to public health, safety, and welfare remedied; and

WHEREAS, on February 22, 2022, the State of Mississippi Public Lands Division issued a Consent to Enter onto State-Owned Property to the City for the purpose of cleaning and demolishing the improvement on the property at no cost to the Office of the Mississippi Secretary of State for Case #CE-22-144 located at 151 Woody Dr., parcel #625-38-2, in Ward 7 of the City of Jackson; and

WHEREAS, the Community Improvement Division of the Department of Planning and Development has a system in which vendors performing services related to the remedying of conditions on property deemed to be a menace to public health, safety, and welfare submit bids; and

WHEREAS, Love Trucking Co., Inc. submitted the lowest bid and through its Member, Dennis Love, agreed to demolish the structure, foundation, steps, and driveway, to cut grass and weeds, to remove trash and debris, and to perform other work to remedy conditions constituting a menace to public health, safety, and welfare on the parcel located at 151 Woody Dr. for the sum of \$6,400.00; and

WHEREAS, Love Trucking Co., Inc. has a principal office address of 761 Woodlake Drive Jackson MS, 39206 according to the information appearing on the Mississippi Secretary of State's website; and

IT IS THEREFORE ORDERED that the Mayor be authorized to execute a contract with Love Trucking Co., Inc. to demolish the structure, foundation, steps, and driveway, to cut grass and weeds, to remove trash and debris, and to perform work to remedy the other conditions on the property located at 151 Woody Dr. deemed to be a menace to public health, safety, and welfare;

IT IS FURTHER HEREBY ORDERED that a sum not to exceed \$6,400.00 shall be paid to Love Trucking Co., Inc. for the services provided from funds budgeted for the Division.

Consent Agenda No.
May 23, 2023
(Dotson, Lumumba)

15

CITY COUNCIL AGENDA ITEM 10 POINT DATA SHEET

03/29/2023
DATE

POINTS		COMMENTS			
1.	Brief Description/Purpose	This item provides for the remedying of conditions for case adjudicated a menace by the City Council. The Order is asking that the Mayor be authorized to execute a contract for the completion of work to improve public health, safety and welfare.			
2.	Public Policy Initiative <ol style="list-style-type: none"> 1. Youth & Education 2. Crime Prevention 3. Changes in City Government 4. Neighborhood Enhancement 5. Economic Development 6. Infrastructure and Transportation 7. Quality of Life 	<ol style="list-style-type: none"> 1. Neighborhood Enhancement 2. Crime Prevention 7. Quality of Life 			
3.	Who will be affected	All City of Jackson residents.			
4.	Benefits	Cleaning of the private property will remove threats to the health, safety and welfare of surrounding residents while improving the condition of the community.			
5.	Schedule (beginning date)	To be determined pending execution of contract.			
6.	Location: <ul style="list-style-type: none"> ▪ WARD ▪ CITYWIDE (yes or no) (area) ▪ Project limits if applicable 	Ward 7			
7.	Action implemented by: <ul style="list-style-type: none"> ▪ City Department <input type="checkbox"/> ▪ Consultant <input type="checkbox"/> 	PLANNING AND DEVELOPMENT DEPARTMENT COMMUNITY IMPROVEMENT DIVISION			
8.	COST	\$6,400.00			
9.	Source of Funding <ul style="list-style-type: none"> ▪ General Fund ▪ Grant <input type="checkbox"/> ▪ Bond <input type="checkbox"/> ▪ Other <input type="checkbox"/> 	General Funding (001-444-70-6485)			
10.	EBO participation	ABE _____ % AABE _____ % WBE _____ % HBE _____ % NABE _____ %	WAIVER WAIVER WAIVER WAIVER WAIVER	yes ___ no ___ yes ___ no ___ yes ___ no ___ yes ___ no ___ yes ___ no ___	N/A ___ N/A ___ N/A ___ N/A ___ N/A ___



Memo

To: Chokwe Lumumba, Mayor

From: Chloe Dotson, Director
Department of Planning and Development

Date: 4/18/2023

Re: Agenda Item

The attached agenda item is an Order requesting that the Mayor execute a contract with Love Trucking Co., Inc. for to demolish the structure, foundation, steps, and driveway; cut grass and weeds; remove trash and debris for certain parcels of real property in the City of Jackson declared to be a menace to public health, safety and welfare pursuant to Section 21-19-11 of Mississippi Code.

Therefore, we respectfully request that you authorize the execution of contract and related documents for project selected and awarded to the said contractor for the following case #CE-22-144.

Thank you for your prompt consideration in this matter.

Office of the City Attorney

455 East Capitol Street
Post Office Box 2779
Jackson, Mississippi 39207-2779
Telephone: (601) 960-1799
Facsimile: (601) 960-1756

OFFICE OF THE CITY ATTORNEY

This ORDER AUTHORIZING THE MAYOR TO EXECUTE A CONTRACT BETWEEN THE CITY OF JACKSON AND LOVE TRUCKING CO. INC. TO DEMOLISH A STRUCTURE, FOUNDATION, STEPS AND DRIVEWAY, TO CUT GRASS AND WEEDS, TO REMOVE TRASH AND DEBRIS, AND TO PERFORM OTHER WORK TO REMEDY THE CONDITIONS ON STATE-OWNED PROPERTY THAT CONSTITUTE A MENACE TO PUBLIC HEALTH, SAFETY, AND WELFARE ACCORDING TO MISSISSIPPI CODE ANNOTATED SECTION 21-19-11 FOR CASE #CE-22-144 LOCATED AT 151 WOODY DR. PARCEL # 625-38-2 - \$6,400.00 is legally sufficient for placement in NOVUS Agenda.

Catoria Martin, City Attorney

Kristie Metcalfe, Deputy City Attorney 

5/3/23
Date

16

OFFICE OF THE CITY ATTORNEY
JDC
4/28/23

ORDER AUTHORIZING THE MAYOR TO EXECUTE A CONTRACT BETWEEN THE CITY OF JACKSON AND SOCRATES GARRETT ENTERPRISES, INC. TO DEMOLISH THE STRUCTURE, FOUNDATION, STEPS, AND DRIVEWAY; CUT GRASS AND WEEDS; REMOVE TRASH AND DEBRIS; AND REMEDY CONDITIONS ON PRIVATE PROPERTY WHICH CONSTITUTE A MENACE TO PUBLIC HEALTH, SAFETY, AND WELFARE ACCORDING TO MISSISSIPPI CODE ANNOTATED SECTION 21-19-11 FOR CASE #CE-21-866 – 5478 QUEEN MARY LN. – \$5,925.00 – WARD 4

WHEREAS, on August 2, 2022, the Jackson City Council approved a resolution declaring certain parcels of real property in the City of Jackson to be a menace to public health, safety, and welfare pursuant to Section 21-19-11 of the Mississippi Code following an administrative hearing held on July 12, 2022 for Case CE-21-866 located in Ward 4 of the City of Jackson; and

WHEREAS, the Community Improvement Division of the Planning and Development Department maintains a list of licensed, bonded, and insured contractors that received and responded to the request for bids for the demolition project located at 5478 Queen Mary Ln; and

WHEREAS, Socrates Garrett Enterprises, Inc. submitted the lowest bid of \$5,925.00; and

WHEREAS, a municipal contract for the professional services of a contractor is not subject to advertising and bidding requirements set forth in Section 31-7-13 of the Mississippi Code of 1972; and

WHEREAS, upon receipt of a written Notice to Proceed, Socrates Garrett Enterprises, Inc. through its representative, Leland Socrates Garrett, has agreed to demolish the structure, foundation, steps, driveway and/or cut grass, weeds, shrubbery, fence line, bushes, and saplings; remove trash, debris, tires, crates, appliances, building materials, furniture, and fallen tree parts; clean curbside; and remedy conditions constituting a menace to public health, safety, and welfare for the parcel located at 5478 Queen Mary Ln. in an amount not to exceed \$5,925.00; and

WHEREAS, Socrates Garrett Enterprises, Inc. has a principal office located at 2659 Livingston Rd., Jackson, MS 39213, according to the information appearing on the Mississippi Secretary of State's website.

IT IS, THEREFORE, ORDERED that the Mayor is authorized to execute a contract with Socrates Garrett Enterprises, Inc. to demolish the structure and remedy conditions on the property located at 5478 Queen Mary Ln deemed to be a menace to public health, safety, and welfare.

IT IS FURTHER HEREBY ORDERED that a sum not to exceed \$5,925.00 shall be paid to Socrates Garrett Enterprises, Inc. upon the completion of the services provided from funds budgeted for the Division.

CITY COUNCIL AGENDA ITEM 10 POINT DATA SHEET

12/27/2022
DATE

POINTS		COMMENTS					
1.	Brief Description/Purpose	This item provides for the remedying of conditions for case adjudicated a menace by the City Council. The Order is asking that the Mayor be authorized to execute a contract for the completion of work to improve public health, safety and welfare.					
2.	Public Policy Initiative 1. Youth & Education 2. Crime Prevention 3. Changes in City Government 4. Neighborhood Enhancement 5. Economic Development 6. Infrastructure and Transportation 7. Quality of Life	1. Neighborhood Enhancement 2. Crime Prevention 7. Quality of Life					
3.	Who will be affected	All City of Jackson residents.					
4.	Benefits	Cleaning of the private property will remove threats to the health, safety and welfare of surrounding residents while improving the condition of the community.					
5.	Schedule (beginning date)	To be determined pending execution of contract.					
6.	Location: ▪ WARD ▪ CITYWIDE (yes or no) (area) ▪ Project limits if applicable	Ward 4					
7.	Action implemented by: ▪ City Department <input type="checkbox"/> ▪ Consultant <input type="checkbox"/>	PLANNING AND DEVELOPMENT DEPARTMENT COMMUNITY IMPROVEMENT DIVISION					
8.	COST	\$5,925.00					
9.	Source of Funding ▪ General Fund ▪ Grant <input type="checkbox"/> ▪ Bond <input type="checkbox"/> ▪ Other <input type="checkbox"/>	General Funding (001-444-70-6446)					
10.	EBO participation	ABE _____ %	WAIVER	yes ___	no ___	N/A ___	
		AABE _____ %	WAIVER	yes ___	no ___	N/A ___	
		WBE _____ %	WAIVER	yes ___	no ___	N/A ___	
		HBE _____ %	WAIVER	yes ___	no ___	N/A ___	
		NABE _____ %	WAIVER	yes ___	no ___	N/A ___	



Memo

To: Chokwe Lumumba, Mayor

From: Chloe Dotson, Director
Department of Planning and Development

Date: 3/28/2023

Re: Agenda Item

The attached agenda item is an Order requesting that the Mayor execute a contract with Socrates Garrett Enterprises, Inc., for to demolish the structure, foundation, steps, and driveway; cut grass and weeds; remove trash and debris for certain parcels of real property in the City of Jackson declared to be a menace to public health, safety and welfare pursuant to Section 21-19-11 of Mississippi Code.

Therefore, we respectfully request that you authorize the execution of contract and related documents for project selected and awarded to the said contractor for the following case #CE-21-866.

Thank you for your prompt consideration in this matter.

Office of the City Attorney

455 East Capitol Street
Post Office Box 2779
Jackson, Mississippi 39207-2779
Telephone: (601) 960-1799
Facsimile: (601) 960-1756

OFFICE OF THE CITY ATTORNEY

OFFICE OF THE CITY ATTORNEY
4/12/23

This **ORDER AUTHORIZING THE MAYOR TO EXECUTE A CONTRACT BETWEEN THE CITY OF JACKSON AND SOCRATES GARRETT ENTERPRISES, INC. TO DEMOLISH THE STRUCTURE, FOUNDATION, STEPS, AND DRIVEWAY; CUT GRASS AND WEEDS; REMOVE TRASH AND DEBRIS; AND REMEDY CONDITIONS ON PRIVATE PROPERTY WHICH CONSTITUTE A MENACE TO PUBLIC HEALTH, SAFETY, AND WELFARE ACCORDING TO MISSISSIPPI CODE ANNOTATED SECTION 21-19-11 FOR CASE #CE-21-866- 5478 QUEEN MARY LN.- \$5,925.00** is legally sufficient for placement in NOVUS Agenda.



Catoria Martin, *City Attorney*
Kristie Metcalfe, *Deputy City Attorney* 

5/3/23
Date

17

OFFICE OF THE CITY ATTORNEY
RC
4/26/23

ORDER AUTHORIZING CANCELLATION OF LIEN WITH THE HINDS COUNTY TAX COLLECTOR FOR ADJUDICATED COSTS AND PENALTIES ASSESSED FOR CLEANING PARCEL NUMBER 128-202 LOCATED AT 934 CLAIBORNE AVENUE, JACKSON MISSISSIPPI.

WHEREAS, On May 22, 2018 the governing authorities for the City of Jackson passed a resolution that declared property located at 934 Claiborne Avenue to be a menace to public health, safety, and welfare; and

WHEREAS, pursuant to Section 21-19-11 of the Mississippi Code, the City of Jackson remedied conditions on the property constituting a menace to public health, safety, and welfare when the owner of the property failed to do so; and

WHEREAS, on October 15, 2019 the governing authorities for the City of Jackson passed a resolution that adjudicated costs and penalties totaling two thousand five hundred two dollars (\$2,502.00) for the cleaning of property located at 934 Claiborne Avenue legally described as LOT 10 BLK B ROSEDALE GARDENS; and

WHEREAS, consistent with the provisions of Section 21-19-11, the resolution adjudicating costs and penalties was subsequently included with 2020 municipal ad valorem taxes where payment would be enforced in the same manner as municipal ad valorem taxes; and

WHEREAS, at the time of cleaning, the property was owned by Lee Jackson; and

WHEREAS, the notice to proceed was issued on December 3, 2018, and the property was sold on December 14, 2018.

WHEREAS, at the time costs and penalties were adjudicated, ownership had changed to Charles D. King; and

WHEREAS, the property owners did not receive proper notice.

IT IS, THEREFORE, ORDERED that the clean-up assessment imposed on Parcel number 128-202 located at 934 Claiborne Avenue be removed from the Hinds County Real Property Billing Roll.

IT IS FURTHER ORDERED that any acts required and necessary to effect the cancellation of the lien arising out of the imposed clean-up assessment for Case 2017-1123 are authorized to be performed.

Consent Agenda
ITEM NO: 17
DATE May 23, 2023
BY (DOTSON, LUMUMBA)

CITY COUNCIL AGENDA ITEM 10 POINT DATA SHEET DATE April 6, 2023

P O I N T S		C O M M E N T S
1.	Brief Description/Purpose	ORDER AUTHORIZING CANCELLATION OF LIEN WITH THE HINDS COUNTY TAX COLLECTOR FOR ADJUDICATED COSTS AND PENALTIES ASSESSED FOR CLEANING PARCEL NUMBER 128-202 LOCATED AT 934 CLAIBORNE AVENUE, JACKSON MISSISSIPPI.
2.	Public Policy Initiative 1. Youth & Education 2. Crime Prevention 3. Changes in City Government 4. Neighborhood Enhancement 5. Economic Development 6. Infrastructure and Transportation 7. Quality of Life	N/A
3.	Who will be affected	An improperly imposed debt will be removed from the owner.
4.	Benefits	Approval of the recommended action will keep the City in good standing for acknowledging and correcting an improperly imposed debt.
5.	Schedule (beginning date)	Earliest date following City Council meeting.
6.	Location: ■ WARD ■ CITYWIDE (yes or no) (area) ■ Project limits if applicable	Ward 5
7.	Action implemented by: ■ City Department ■ Consultant	DEPARTMENT OF PLANNING AND DEVELOPMENT COMMUNITY IMPROVEMENT DIVISION
8.	COST	Document Filing Fee
9.	Source of Funding ■ General Fund ■ Grant ■ Bond ■ Other	General Fund 001-444-70-6447
10.	EBO participation	ABE _____% WAIVER yes ___ no ___ N/A _____ AABE _____% WAIVER yes ___ no ___ N/A _____ WBE _____% WAIVER yes ___ no ___ N/A _____ HBE _____% WAIVER yes ___ no ___ N/A _____ NABE _____% WAIVER yes ___ no ___ N/A _____



Memo

To: Chokwe Lumumba, Mayor

**From: Chloe Dotson, Director
Department of Planning and Development**

Date: April 6, 2022

Re: Agenda Item

The attached agenda item is an order requesting that the Jackson City Council authorize the filing of Cancellation of Lien with the Hinds County Tax Collector's office in reference to Parcel number 128-202 located at 934 Claiborne Avenue. for case 2017-1123. A lien in the amount of \$2,502.00 was included with 2020 municipal ad valorem taxes so that payment for clean-up assessment could be enforced in the same manner as municipal ad valorem taxes. Ownership changed hands after City-performed cleanup but before Lis Pendens was filed. Therefore, the current owner was not properly notified.

Community Improvement has since updated its practices. Lis Pendens notices are filed prior to issuing the Notice to Proceed following a new title search rather than after costs and penalties are adjudicated.

Your consideration in this matter is appreciated.

If you have questions and/or need clarification, please do not hesitate to contact my office at (601) 960-1172 or e-mail cdotson@jacksonms.gov.



Community Improvement Division

Owner Name	CARSON CHARLIE	Map-Parcel-Sub	128-202-0
Street Address	CLAIBORNE AVE 934	Owner Address	934 CLAIBORNE AVE
Inspector Name	CHRISTOPHER SWEENEY		JACKSON MS 39209
Case Number	2017-1123		
Narrative/Problem:	Board-up and secure house and cut grass, weeds and remove trash and debris, cut shrubbery, fence line, bushes, saplings, remove wooden boards, building materials, tree limbs, tree parts, tires, clean curbside.		
Comments:	ADJ. 500 DETERMINATION LETTER POSTED 5-24-18 6/6/18 QUOTE AWARDED TO CHRISTOPHER PARTEE, PARTEE & ASSOICATES, LLC \$1820.00		
Complaint Type:	BOARD-UP, SECURE, REMOVE DEBRIS, CUT GRAS		
Bidder Name		Bid Price	
Bidder Address		Notice to Proceed	<input type="checkbox"/>
City/State/Zip		CDBG	<input type="checkbox"/>
Bidder Phone #		Completed	<input type="checkbox"/>

<i>Tracking Information</i>		
<i>Description</i>	<i>Date</i>	<i>Memo</i>
NTP Date	12/3/2018	
Payment Authoriza	1/7/2019	\$2,502.00
First Inspection	3/23/2017	
Hearing	4/11/2017	
Council Date	5/22/2018	
Adjudication Date	9/6/2019	
Lis Pendens Notic	6/10/2020	

CONTRACT FOR DEED

Property: Tax Parcel 128-202, also known as 934 Claiborne Ave., Hinds County, MS

Seller shall quitclaim the interest in the Property acquired at the August 2016 tax sale when Seller has received payment in full.

Purchase Price and Payment Terms:

\$4,500, plus interest computed herein at a rate of 1.5% per month payable as follows: \$300 down payment on or before December 14, 2018, \$500 payment on January 15, 2019 with the balance paid in thirteen (13) equal monthly payments of \$300 beginning February 15, 2019 and ending February 15, 2020, plus a final payment of \$222 due March 15, 2020.

In addition, at the time of the final payment Buyer shall pay to Seller, per parcel, \$250 "closing costs" as reimbursement for tax deed and quitclaim deed filing fees and related administrative costs. An additional 3% will be added to payments made by credit card to cover Visa/MasterCard/Amex fees.

Payment is DUE the 15th of the month. If payment is RECEIVED after the 20th of the month, Buyer must pay a Late Fee of \$40. Separately, Buyer will be charged \$20.00 for checks returned for insufficient funds. All payments should be made to Seller at the following address:

Viking Investments
PO Box 321
Jackson, Mississippi 39205
601-326-1639

Agreement: Buyer agrees to purchase and Seller agrees to convey by quitclaim all of Seller's interest in the Property described above acquired at the August 2016 tax sale in accordance with this Contract. Seller retains all mineral rights, together with the rights of ingress and egress for the development and removal of same.

Taxes and Liens: Buyer shall be responsible for any lis pendens, outstanding property assessments, back and/or current property taxes, liens, judgments, encumbrances, deficiencies or other items existing and/or of record. Buyer understands that 2016 and subsequent years' taxes, interest and penalties remain unpaid and are the responsibility of Buyer. Buyer agrees to pay 2016 taxes before August 15, 2019 and 2017 taxes before August 15, 2020. If Buyer fails to pay any ad valorem taxes on the Property in accordance with this Agreement Buyer will be in default of Contract and will be subject to the terms spelled out in the Default Provision of the Contract.

C.D.K. By initialing here you acknowledge your obligation in regards to taxes.

Insurance: Buyer shall purchase fire & casualty insurance in the amount at least as much as owed to Seller, naming Seller as loss payee.

Default: The first payment must be on time and in full or this Contract may be cancelled by Seller. Thereafter, if payment is RECEIVED more than 5 days past due, Buyer agrees to pay a late charge of \$40. If Buyer fails to make any payment due hereunder (or under any other contract between Seller and Buyer relating to a separate property) within 30 days of the due date thereof, Seller shall have the right to (1) collect any rents or other amounts payable to Buyer from any tenant or purchaser of the Property, (2) terminate Buyer's rights under this Contract (in which event Buyer shall forfeit all payments and become a tenant at sufferance of Seller with rent thereafter due for any time Buyer remains in the Property in an amount equal to two times the principal and interest payment provided for prior to the default, and any then unpaid principal and interest payments shall be considered rent due and not principal or interest and any payments thereafter made by Buyer shall be considered payments of rent), and (3) declare the entire unpaid principal and interest at once due and payable. In the event of default, Buyer shall also be

liable for and agrees to pay all costs of collection and enforcement, including, but not limited to, reasonable attorney's fees for the services of counsel employed to collect the amounts due hereunder or to enforce any provision hereof. Further, Buyer agrees that, with receipt of notice, Buyer will vacate the Property within three days.

Warranties: Seller and Buyer acknowledge that this is an "As is", "Where is" sale, and Seller has not made and makes no warranties or representations regarding the Property, express or implied, including, without limitation, its habitability, condition or fitness for any particular use or purpose or merchantability of title. Buyer agrees if the full purchase price is paid in accordance with this Contract, the Property shall be quitclaimed by Seller and accepted by Buyer in an "As is" condition on the closing date.

Maintenance & Repairs. Buyer shall maintain and make repairs to the Property, including maintaining the lawn and landscaping, and shall keep the Property clean and free of debris.

Arbitration. BY EXECUTING THIS AGREEMENT, THE PARTIES HERETO AGREE THAT EXCEPT AS PROVIDED IN THE NEXT PARAGRAPH, ANY DISPUTE RELATING TO OR IN RESPECT OF THIS AGREEMENT (INCLUDING THE AGREEMENTS AND ADDENDA FORMING PART OF THIS AGREEMENT), ITS NEGOTIATION, EXECUTION, PERFORMANCE, SUBJECT MATTER, OR ANY COURSE OF CONDUCT OR DEALING OR ACTIONS UNDER OR IN RESPECT OF THIS AGREEMENT, SHALL BE SUBMITTED TO AND RESOLVED EXCLUSIVELY PURSUANT TO ARBITRATION IN ACCORDANCE WITH THE COMMERCIAL ARBITRATION RULES OF THE AMERICAN ARBITRATION ASSOCIATION. SUCH ARBITRATION SHALL TAKE PLACE IN HINDS COUNTY, MISSISSIPPI. DECISIONS PURSUANT TO SUCH ARBITRATION SHALL BE FINAL, CONCLUSIVE AND BINDING ON THE PARTIES. UPON THE CONCLUSION OF ARBITRATION, THE PARTIES MAY APPLY TO ANY COURT OF COMPETENT JURISDICTION TO ENFORCE THE DECISION PURSUANT TO SUCH ARBITRATION. THE PREVAILING PARTY IN ARBITRATION SHALL BE ENTITLED TO RECOVER REASONABLE COSTS AND ATTORNEYS FEES FROM THE OTHER PARTY. EXCEPT AS PROVIDED IN THE NEXT PARAGRAPH, THE PARTIES HERETO HEREBY WAIVE AND SHALL NOT SEEK JURY TRIAL IN ANY LAWSUIT, PROCEEDING, CLAIM, COUNTERCLAIM, DEFENSE OR OTHER LITIGATION OR DISPUTE UNDER OR IN RESPECT OF THIS AGREEMENT.

PROVIDED, BUYER AGREES THAT SHOULD BUYER DEFAULT HEREUNDER AND BECOME A TENANT AT SUFFERANCE PURSUANT TO THE DEFAULT PROVISIONS OF THIS AGREEMENT OR IF BUYER SHOULD DEFAULT UNDER ANY NOTE OR DEED OF TRUST EXECUTED IN CONNECTION WITH THIS AGREEMENT, SELLER SHALL HAVE THE RIGHT TO FORECLOSE AND TO EVICT AND REMOVE BUYER PURSUANT TO ANY AVAILABLE MEANS INCLUDING EVICTION IN JUSTICE COURT AND WRONGFUL ENTRY AND DETAINER IN COUNTY OR CIRCUIT COURT, WITHOUT SELLER HAVING TO AVAIL ITSELF OF ARBITRATION.

This Contract comprises the entire agreement of the Seller and the Buyer, and it is agreed that no other representation or agreements have been made or relied upon. Additionally, until a signed contract and good funds representing the initial payment have been received by Seller, Seller reserves the right to cancel this agreement. All sales are final.

Seller: Viking Investments

Buyer: Charles King

By: [Signature]

By: Charles D. King

Date: 12/13/18

Date: Dec 14, 2018

Sectional Subdivision List

Your search found 47 records.

Page 2 of 4

1602 Subdivision: ROSEDALE GARDENS

Grantor Grantee	Instrument Book-Page	Date	Block	Lot
CHANCERY CLERK JACKSON LEE	REL 7138-3920	06-03-2013 <u>Remark</u>	B	10
TAX COLLECTOR WOODS COVE IV LLC	TAX SALE 2014-1090	08-31-2015 <u>Remark</u>	B	10
TAX COLLECTOR CASA PORCA, LLC	TAX SALE 2015-1048	08-29-2016 <u>Remark</u>	B	10
TAX COLLECTOR STATE OF MISSISSIPPI	TAX SALE 2016-0754	08-28-2017 <u>Remark</u>	B	10
CHANCERY CLERK ALL PERSONS	AFFID 7211-0193	09-18-2017 <u>Remark</u>	B	10
TAX COLLECTOR STATE OF MISSISSIPPI	TAX SALE 2017-0671	08-27-2018 <u>Remark</u>	B	10
CHANCERY CLERK ALL PERSONS	AFFID 7225-0243	09-17-2018 <u>Remark</u>	B	10
TAX COLLECTOR STATE OF MISSISSIPPI	TAX SALE 2018-0834	08-26-2019 <u>Remark</u>	B	10
JACKSON CITY OF JACKSON LEE	LIS PEN 0050-1146	06-25-2020	B	10
TAX COLLECTOR STATE OF MISSISSIPPI	TAX SALE 2019-0663	08-31-2020 <u>Remark</u>	B	10
TAX COLLECTOR STATE OF MISSISSIPPI	TAX SALE 2019-0663	08-31-2020 <u>Remark</u>	B	10
TAX COLLECTOR STATE OF MISSISSIPPI	TAX SALE 2019-0663	08-31-2020 <u>Remark</u>	B	10
TAX COLLECTOR STATE OF MISSISSIPPI	TAX SALE 2019-0663	08-31-2020 <u>Remark</u>	B	10
TAX COLLECTOR STATE OF MISSISSIPPI	TAX SALE 2019-0663	08-31-2020 <u>Remark</u>	B	10
TAX COLLECTOR STATE OF MISSISSIPPI	TAX SALE 2019-0663	08-31-2020 <u>Remark</u>	B	10

Page 1

Page 3

[Back](#) [Search](#)

DT - Deed of Trust (this instrument shows financing info for property being purchased)

QCD - Quit Claim Deed (instrument shows conveying ownership from one party to another)

REL - Release (often referred to as Authority to Cancel) (this instrument shows that a Deed of Trust has been satisfied/paid in full)

WD - Warranty Deed (instrument shows conveying ownership from one party to another)

LIS PENS - Lis Penden (this instrument is a lien placed on property, ex. The City often places Lis Pens on property that the city has to clean up/mow grass, etc....)

Office of the City Attorney

455 East Capitol Street
Post Office Box 2779
Jackson, Mississippi 39207-2779
Telephone: (601) 960-1799
Facsimile: (601) 960-1756

OFFICE OF THE CITY ATTORNEY

This **ORDER AUTHORIZING CANCELLATION OF LIEN WITH THE HINDS COUNTY TAX COLLECTOR FOR ADJUDICATED COSTS AND PENALTIES ASSESSED FOR CLEANING PARCEL NUMBER 128-202 LOCATED AT 934 CLAIBORNE AVENUE, JACKSON MISSISSIPPI** is legally sufficient for placement in NOVUS Agenda.



Catoria Martin, *City Attorney*

Kristie Metcalfe, *Deputy City Attorney*



4/28/23
Date

OFFICE OF THE CITY ATTORNEY
4/28/23

18

ORDER ACCEPTING PAYMENT OF \$1,600.42 FROM STATE FARM INSURANCE COMPANY ON BEHALF OF THEIR INSURED ROY DAVIDSON AS A VEHICLE PROPERTY DAMAGE SETTLEMENT.

OFFICE OF THE CITY ATTORNEY
H. Brown
H. Brown

IT IS HEREBY ORDERED by the City Council for the City of Jackson, Mississippi, that the City Attorney or designee, be authorized to execute all necessary documents and accept payment in the amount of \$1,600.42 as a vehicle property damage and loss of use settlement by Risk Management for damages sustained to City of Jackson vehicle SUV-0144 on March 08, 2022.

APPROVED FOR AGENDA:

Item # 18
Agenda Date: 23 MAY 2023
By: Lumumba, Martin

05/10/2023
{TBP}

CITY COUNCIL AGENDA ITEM 10 POINT DATA SHEET

05/10/2023

DATE

POINTS		COMMENTS						
1.	1. Brief Description/Purpose	ORDER ACCEPTING PAYMENT OF \$1,600.42 FROM STATE FARM INSURANCE COMPANY ON BEHALF OF THEIR INSURED ROY DAVIDSON AS A VEHICLE PROPERTY DAMAGE SETTLEMENT						
2.	Public Policy Initiative 2. Crime Prevention 3. Changes in City Government 4. Neighborhood Enhancement 5. Economic Development 6. Infrastructure and Transportation 7. Quality of Life	N/A						
3.	Who will be affected	City of Jackson						
4.	Benefits	N/A						
5.	Schedule (beginning date)	N/A						
6.	Location: ▪ WARD ▪ CITYWIDE (yes or no) (area) ▪ Project limits if applicable	N/A						
7.	Action implemented by: ▪ City Department <input checked="" type="checkbox"/> ▪ Consultant <input type="checkbox"/>	Office of the City Attorney						
8.	COST	\$1,600.42						
9.	Source of Funding ▪ General Fund <input checked="" type="checkbox"/> ▪ Grant <input type="checkbox"/> ▪ Bond <input type="checkbox"/> ▪ Other <input type="checkbox"/>							
10.	EBO participation	ABE	_____ %	WAIVER	yes ___	no ___	N/A	<u>X</u>
		AABE	_____ %	WAIVER	yes ___	no ___	N/A	<u>X</u>
		WBE	_____ %	WAIVER	yes ___	no ___	N/A	<u>X</u>
		HBE	_____ %	WAIVER	yes ___	no ___	N/A	<u>X</u>
		NABE	_____ %	WAIVER	yes ___	no ___	N/A	<u>X</u>

MEMO

**TO: Chokwe Antar Lumumba, Mayor
City of Jackson**

DATE: May 10, 2023

**RE: Settlement of Vehicle Claim from State Farm Insurance Co.
{Roy Davidson 14542-DT}**

On 3/8/22, Roy Davidson driving a 1996 Ford Crown Victoria was traveling east on Robinson Street when his vehicle rear-ended JPD Officer Steven Long's 2020 Dodge Durango (SUV-0144) near the intersection of Dixon Road. Officer Long filed a worker's compensation claim due to his injuries which is being handled by the City's worker's compensation carrier. The City does not have any outstanding subrogation claims regarding Officer Long's injuries. Both vehicles were able to be driven away from the scene.

A demand letter was sent to State Farm Insurance Company in the amount of \$1,600.42. State Farm Insurance mailed the settlement check in the amount of \$1,600.42, which does include loss of use (\$250.00).

It is hereby recommended, pending City Council approval, that the City of Jackson accepts the aforementioned payment as a property damage settlement. The amount of \$1,600.42 represents amount estimated to repair vehicle and loss of use. If additional information is required, please let me know.



**Carrie Johnson, Senior Deputy City Attorney
Office of the City Attorney**

CJ/tbp

Attachments

PAYMENT NO 1 09 959359 J
PAYMENT AMOUNT \$1,600.42
ISSUE DATE 05-01-2023
AUTHORIZED BY GUERRERO, LEILANI
PHONE (844) 292-8615

CLAIM NO 24-31P0-89S
LOSS DATE 03-08-2022
POLICY NO 0443-079-24B
INSURED DAVIDSON, ROY L

CITY OF JACKSON RISK MANAGEMENT DIVISION
PO BOX 17
JACKSON MS 39205-0017

RECEIVED

MAY 08 2023

RISK MANAGEMENT

REMARKS Claim #14542 Date of Accident 03/08/2022 Jackson Police D
ept Vehicle

COVERAGE DESCRIPTION	ON BEHALF OF	AMOUNT
PROPERTY DAMAGE LIABILITY	JACKSON POLICE DEPT	1,600.42

RETAIN STUB FOR RECORDS

State Farm STATE FARM MUTUAL AUTOMOBILE INSURANCE COMPANY
AUTO INJURY INJ-B2 OFFICE CO. PAGECNTQ.P74
WELLS FARGO BANK, N.A. 64-975/612 SAVANNAH, GA
1 09 959359 J
DATE 05-01-2023 M-M DD YY-YY
CLAIM NO 24-31P0-89S INSURED DAVIDSON, ROY L
LOSS DATE 03-08-2022
*****EXACTLY ONE THOUSAND SIX HUNDRED AND 42/100 DOLLARS \$*****1,600.42
Pay to the Order of: CITY OF JACKSON RISK MANAGEMENT DIVISION
Michael Flynn AUTHORIZED SIGNATURE
John Terney AUTHORIZED SIGNATURE

SECURED DOCUMENT WATERMARK APPEARS ON BACK, HOLD AT 45° ANGLE FOR VIEWING

⑈0917959359⑈ ⑆061209756⑆ 2079900091274⑈

THE CITY OF
JACKSON
MISSISSIPPI
OFFICE OF THE CITY ATTORNEY
Risk Management Division

April 24, 2023

FIFTH REQUEST

State Farm Insurance Company
ATTN: Michael Nchale, Adjuster
One State Farm Plaza
Bloomington, IL 61710

Re: Damages to the City of Jackson Property
Date of Accident: 3/8/2022
Description of Property: Vehicle Accident involving SUV-0144
Location: Robinson St near Dixon Rd
Your Insured: Roy Davidson - Claim# 14542
Your Claim#: 24-32J205L
Amount of Lien: \$1,350.42 - vehicle repairs
\$ 250.00 - Loss of use
\$1,600.42 - Total Lien

Dear Mr. Nchale:

The City of Jackson has completed the investigation of the above captioned claim. Based on our findings, your insured is responsible for the accident. The City of Jackson is seeking full reimbursement for the cost of repairs.

Attached, you will find a copy of the estimate for the cost of repairs, please make the check payable to the City of Jackson, and send it to the following address:

City of Jackson
ATTN: Risk Management Division
PO Box 17
Jackson, Ms 39205-0017

Thank you for your cooperation in this matter. If you have any questions, please do not hesitate to call me at (601) 960-1738.

Sincerely,



Dornice W. Thurman, Claims Investigator
Risk Management Division

DWT

Enclosures

Jenkins Automotive

Jenkins Automotive
 1120 England Road
 Jackson, MS 39209
 Business Phone: (601) 874-0440
 dougmontrel@gmail.com

Estimate

Est # 99
 ID # 12529776

Vehicle Info

2019 Dodge -Durango SXT
 1C4RDHFG8LC307806
 Ext. Color: Bright White - PW7
 License: SUV144
 Body Type: 4 Door Utility
 Engine: 3.6L 6 Cyl Gas Injected
 Drive Type: 2WD

Owner

Jackson police department
 All parts supplied by city garage

Insurance Company

Inspection Date: 10/19/2022
 Repair Days: 2

RECEIVED

OCT 19 2022

	Oper	Description	Part Number	Price	Labor
REAR BUMPER					
1	Replace	REAR LWR BUMPER FASCIA Included in R&R Bumper Cover	68260788AA	\$487.00	0.4 hrs. Body
2	Repair	REAR BUMPER COVER			2.4 hrs. Paint panel
		1 hrs. Clearcoat, 1.2 hrs. Blend			2.2 hrs. Refinish
3	R&I	REAR BUMPER COVER			2.5 hrs. Body
4	Replace	FLEX ADDITIVE		\$10.00	
5	Other	HAZARDOUS WASTE REMOVAL Sublet - Nontaxed			
				\$5.00	

Totals

Type	Labor Time	Cost	Total	Taxable
Body Labor	2.9	\$80.00	\$232.00	
Paint Labor	4.6	\$80.00	\$368.00	
Paint Supplies	4.6	\$42.00	\$193.20	✓
Nontaxed			\$5.00	
OEM Parts			\$487.00	✓
Other Parts			\$10.00	✓
Taxable Amount			\$690.20	
Tax	8%		\$55.22	
Nontaxable Amount			\$605.00	
Grand Total			\$1,350.42	

PINE BELT

DURANGO

P2

P



CITY OF JACKSON

DODGE



PINE BELT
DURANGO

POLICE

144

P2

CITY OF JACKSON

DODGE

MISSISSIPPI
G 88018
GOVERNMENT
SAFETY Dodge Jeep RAM

POLICE

PIRE BELLY
SURFBOARD

P2



CENTRAL
FILE
COPY

CITY OF JACKSON
ACCIDENT REPORT INVOLVING CITY VEHICLE

MAR 22 2022

BY Jap

Date of Accident March 08, 2022 Time 1725 AM/PM
Date this form completed March 08, 2022 Time 1854 AM/PM

SECTION I. VEHICLE #1 (CITY VEHICLE)

1. Vehicle # 0144 Year 2021 Make Dodge Durango Type (Sedan, Pick-up, etc.) SUV Dept Police
2. Operator's Name Steven Long Employee # 097448 SSN [REDACTED] Date of Birth 11-07-1974
3. City Driver License # Unknown State Driver License # [REDACTED]
4. Home address [REDACTED] City/State/Zip Code Jackson/ Ms. 39209 Phone # [REDACTED]
5. Parts of vehicle damaged Rear Driver Side Lower Bumper Approximate cost of repairs \$ Unknown
6. Location of Accident Robinson Road and Dixon Road
7. Were the appropriate law enforcement officials notified immediately? Yes () No ()
8. If not, why? _____
9. Name of Investigating Officer Terrence Mayfield Badge # 2372 Employee # 103880 Case # 2022-025912
10. Vehicle # 1 was going (North, East, Parked, etc.) East on Robinson Road (Street)
11. Name, Address, Zip Code & Phone # of Witness (s) None

SECTION II. VEHICLE #2 (OTHER VEHICLE)

1. Year 1996 Make Ford Type (Sedan, Pick-up, etc.) Crown Victoria
2. Operator's Name Roy Davidson Phone # [REDACTED]
3. Street address [REDACTED] City/State/Zip Code Jackson/ Ms. 39209
4. Parts of vehicle damaged No Damage Approximate cost of repairs \$ N/A
5. Vehicle # 2 was going (North, East, Parked, etc.) East on Robinson Road (Street)

INDICATE
NORTH
BY ARROW



Remarks: Corporal Long was stationary at the intersection of Robinson Road and Dixon Road when he was rear ended by a green in color Ford Crown Victoria driven by Roy Davidson.

RECEIVED

MAR 18 2022

RISK MANAGEMENT DIVISION

NOTE: Please attach a separate sheet of paper, if necessary.

I certify that I have supplied all facts pertaining to this accident and the above information is true and correct to the best of my knowledge.

EMPLOYEE'S SIGNATURE [Signature] DATE 3/8/22

SECTION III. SUPERVISOR'S REVIEW & COMMENT SECTION

Comments After arriving on scene, I noticed Corporal Long was still seated inside his patrol car, he advised he was in pain. The patrol vehicle appeared to have minor damage. Corporal Long was not at fault, therefore I do not believe disciplinary action is warranted.

Was the City Employee injured? If yes has the Personal Injury Report been completed? Yes (X) No ()

I certify that I have reviewed the above information and it is correct to the best of my knowledge.

In my opinion the accident is: Preventable () Non-Preventable () Undetermined at this time (X)

Supervisor's Signature [Signature]
Supervisor's Printed Name Bennie Chisholm #1919 Supervisor's Employee # 101450 Date 03/08/2022

SECTION IV. DEPARTMENT HEAD'S REVIEW & COMMENT SECTION

Comments _____

In my opinion the accident is: Preventable () Non-Preventable () Undetermined at this time ()

Department Head's Signature _____ Department _____ Date _____
Department Head's Printed Name _____

Original Copy - Risk Management Division 2nd Copy- Department 3rd Copy - Timekeeper 4th Copy - Employee

3/23/22 VC 3/10/22

Office of the City Attorney

455 East Capitol Street
Post Office Box 2779
Jackson, Mississippi 39207-2779
Telephone: (601) 960-1799
Facsimile: (601) 960-1756

Alvin
OFFICE OF THE CITY ATTORNEY
Alvin

OFFICE OF THE CITY ATTORNEY

This **ORDER ACCEPTING PAYMENT OF \$1,600.42 FROM STATE FARM INSURANCE COMPANY ON BEHALF OF THEIR INSURED ROY DAVIDSON AS A VEHICLE PROPERTY DAMAGE SETTLEMENT** is legally sufficient for placement in NOVUS Agenda.



Catoria Martin, City Attorney

5/14/23

DATE



Carrie Johnson, Senior Deputy City Attorney

5/11/23

DATE

19

City of Jackson

Minute Book Summary

AGENDA DATE: May 23, 2023

ORDER APPROVING CLAIMS APPEARING AT PAGES 452 TO INCLUSIVE THEREON, ON MUNICIPAL 'DOCKET OF CLAIMS' IN THE AMOUNT OF \$3,379,126.59 FOR AND MAKING APPROPRIATION FOR THE PAYMENT THEREOF.

OFFICE OF THE CLERK OF THE BOARD OF ALDERMEN
5/19/23
L. H. THAMES

Fund	Fund Description	Amount
0001	GENERAL FUND	\$850,160.15
0003	SEIZURE & FORF PROP-FED	\$49,666.67
0004	TECHNOLOGY FUND	\$17,570.00
0005	PARKS & RECR. FUND	\$44,132.28
0009	LANDFILL/SANITATION FUND	\$105,610.64
0018	STATE TORT CLAIMS FUND	\$8,292.03
0031	WATER/SEWER OP & MAINT FUND	\$85,528.22
0057	EMPLOYEES GROUP INSURANCE FUND	\$160,563.37
0076	KELLOGG FOUNDATION PROJECT	\$6,041.67
0079	PAYROLL FUND	\$762.84
0085	HOUSING COMM DEV ACT (CDBG) FD	\$192,766.96
0086	EMERGENCY SHELTER GRANT (ESG)	\$5,248.08
0122	H O P W A GRANT - DEPT. OF HUD	\$104,252.51
0173	1% INFRASTRUCTURE TAX	\$126,237.83
0174	MADISON SEWAGE DISP OP & MAINT	\$39.23
0187	TRANSPORTATION FUND	\$483,487.86
0203	JXN CONVENTION & VISITORS BUR	\$333,480.60
00	P E G ACCESS- PROGRAMMING FUND	\$7,291.28
0376	SIEMENS SETTLEMENT ACCOUNT	\$290,854.76
0379	ESG COVID CARES ACT	\$3,487.28
0382	CDBG COVID CARES	\$33,145.18
0390	ZOOLOGICAL PARK	\$18,954.84
0392	2019 7M NOTE	\$113,750.00
0404	DFA-SB2971-PETE BROWN GOLF	\$13,046.00
0406	DFA- THALIA MARA HALL \$2M	\$33,797.37
0420	MDOT-CMPDD PROJECTS	\$281,026.05
0430	2022 GO PLANETARIUM BOND \$7.5M	\$9,932.89
		<u>\$3,379,126.59</u>

APPROVED FOR AGENDA
DEPARTMENT DIRECTOR
LEGAL
CAO
CFO
MAYOR'S OFFICE
ITEM # _____
AGENDA DATE 05/23/23
BY: THAMES, LUMUMBA

INITIALS	DATE
S.T.	05/19/2023
KHS	5/19/2023
RWP/JP	5/19/23
F.M.	05/19/23
CAL	5/19/23

CITY OF JACKSON, MISSISSIPPI
Office of the City Attorney

455 East Capitol Street
Post Office Box 2779
Jackson, Mississippi 39207-2779
Telephone: (601) 960-1799
Facsimile: (601) 960-1756

OFFICE OF THE CITY ATTORNEY
Keyona Stewart
5/19/2023

OFFICE OF THE CITY ATTORNEY

The **CLAIMS DOCKET** for May 23, 2023 in the aggregate amount of
\$ 3,379,126.59 has been reviewed by me and, based on information and belief,
this document is approved as to form pursuant to Miss. Code Ann. § 21-39-7 for entry into
NOVUS Agenda System and for payment authorization by governing authorities.

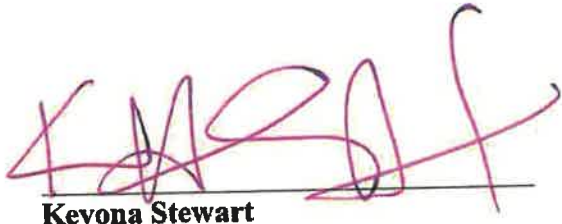

Keyona Stewart

Deputy City Attorney

DATE

5/19/2023

City of Jackson

ACCOUNTS PAYABLE CHECK RUN REPORT

Detail Invoice List

CHECK RUN: CD052323 05/23/2023
 DUE DATE: 05/23/2023



CASH ACCOUNT: 999		1100		POOLED CASH - AP DISBURSEMENTS						
VENDOR		REMIT	PO	TYPE	DUE DATE	INVOICE	AMOUNT	DOCUMENT	VOUCHER	CHECK
69998	1 800 RADIATOR	0000	99230208	INV	05/23/2023	41315469		91344		
	ACCOUNT DETAIL					LINE AMOUNT				
	1 00145125 6316		SBD - D	MOTOR VEH		185.00				
69998	1 800 RADIATOR	0000	99230208	INV	05/23/2023	41313791		91345		
	ACCOUNT DETAIL					LINE AMOUNT				
	1 00145124 6316		SBD - PAV	MOTOR VEH		751.00				
69998	1 800 RADIATOR	0000	99230208	INV	05/23/2023	41317071		91346		
	ACCOUNT DETAIL					LINE AMOUNT				
	1 00144240 6316		OPERATION	MOTOR VEH		108.00				
69998	1 800 RADIATOR	0000	99230208	INV	05/23/2023	41315407		91347		
	ACCOUNT DETAIL					LINE AMOUNT				
	1 00144240 6316		OPERATION	MOTOR VEH		114.00				
69998	1 800 RADIATOR	0000	99230208	INV	05/23/2023	41317163		91348		
	ACCOUNT DETAIL					LINE AMOUNT				
	1 00144240 6316		OPERATION	MOTOR VEH		133.00				
69998	1 800 RADIATOR	0000	99230208	INV	05/23/2023	41346629		91349		
	ACCOUNT DETAIL					LINE AMOUNT				
	1 00144240 6316		OPERATION	MOTOR VEH		222.00				
69998	1 800 RADIATOR	0000	99230208	INV	05/23/2023	41349361		91350		
	ACCOUNT DETAIL					LINE AMOUNT				
	1 00144240 6316		OPERATION	MOTOR VEH		160.00				
69998	1 800 RADIATOR	0000	99230208	INV	05/23/2023	41349362		91351		
	ACCOUNT DETAIL					LINE AMOUNT				
	1 00144240 6316		OPERATION	MOTOR VEH		123.00				
69998	1 800 RADIATOR	0000	99230208	INV	05/23/2023	41350477		91352		
	ACCOUNT DETAIL					LINE AMOUNT				
	1 00144240 6316		OPERATION	MOTOR VEH		187.00				

City of Jackson



ACCOUNTS PAYABLE CHECK RUN REPORT

Detail Invoice List

CHECK RUN: CD052323 05/23/2023
 DUE DATE: 05/23/2023

CASH ACCOUNT:	999	1100	POOLED CASH - AP DISBURSEMENTS				INVOICE	AMOUNT	DOCUMENT	VOUCHER	CHECK
VENDOR	REMIT	PO	TYPE	DUE DATE	INVOICE	AMOUNT	DOCUMENT	VOUCHER	CHECK		
401766 AIRSOUTH, LLC	0000	23001186	INV	05/23/2023	84359986	91292					
ACCOUNT DETAIL											
1 00550125 6315			PROGRAM/ELECTRICA		179.00						
			CHECK TOTAL		179.00						
401933 ALCORN STATE UNIVERSI	0000	23001191	INV	05/23/2023	136	91314					
ACCOUNT DETAIL											
1 00144240 6419			OPERATION OTHER PRO		5,000.00						
			CHECK TOTAL		5,000.00						
41630 ALOHA LOCK & KEY SHOP	0000	77230529	INV	05/23/2023	58789	91272					
ACCOUNT DETAIL											
1 00144225 6419			CRIME LAB OTHER PRO		24.00						
			CHECK TOTAL		24.00						
41630 ALOHA LOCK & KEY SHOP	0000	77230537	INV	05/23/2023	58791	91355					
ACCOUNT DETAIL											
1 00145300 6461			CARE & MA BUILDINGS		44.00						
			CHECK TOTAL		44.00						
72940 ALPHA TRAILER/TRUCKS	0000	23001206	INV	05/23/2023	INV-00006474	90806					
ACCOUNT DETAIL											
1 00550410 6299			PARKS - M OTHER OPE		338.96						
			CHECK TOTAL		338.96						
72940 ALPHA TRAILER/TRUCKS	0000	23001170	INV	05/23/2023	INV-00006473	90807					
ACCOUNT DETAIL											
1 00550410 6317			PARKS - M OTHER REP		991.10						
			CHECK TOTAL		991.10						
40892 AMERICAN PLANNING ASS	0000		INV	05/23/2023	05032023CD	90886					
ACCOUNT DETAIL											
1 00140410 6443			PLANNING DUES, MEM.		129.00						
			CHECK TOTAL		129.00						

Report generated: 05/18/2023 10:26:37
 User: Gloria Jones (glorjaj)
 Program ID: apwarrnt

City of Jackson



ACCOUNTS PAYABLE CHECK RUN REPORT

Detail Invoice List

CHECK RUN: CD052323 05/23/2023
 DUE DATE: 05/23/2023

CASH ACCOUNT: 999 1100		POOLED CASH - AP DISBURSEMENTS									
VENDOR		REMIT	PO	TYPE	DUE DATE	INVOICE	AMOUNT	DOCUMENT	VOUCHER	CHECK	
40892	AMERICAN PLANNING ASS ACCOUNT DETAIL	0000		INV	05/23/2023	05032023LM LINE AMOUNT		90887			
	1 00140410 6443			PLANNING DUES, MEM.		129.00	129.00				
40892	AMERICAN PLANNING ASS ACCOUNT DETAIL	0000		INV	05/23/2023	05032023KS LINE AMOUNT		90889			
	1 00140410 6443			PLANNING DUES, MEM.		129.00	129.00				
40892	AMERICAN PLANNING ASS ACCOUNT DETAIL	0000		INV	05/23/2023	05032023TH LINE AMOUNT		90890			
	1 00140410 6443			PLANNING DUES, MEM.		129.00	129.00				
				CHECK TOTAL			516.00				
30736	APAC MISS INC ACCOUNT DETAIL	0000		EFT	05/23/2023	4000148292 LINE AMOUNT		91884			
	1 00145124 6320			SBD - PAV ASPHALT-R		702.15	702.15				
				CHECK TOTAL			702.15				
401862	ARIA LIGHTS, INC ACCOUNT DETAIL	0000		INV	05/23/2023	6106 LINE AMOUNT		91887			
	1 40643350 6246			DFA-TMH 2MOFFICE FLR		19,566.12	19,566.12				
				CHECK TOTAL			19,566.12				
401246	ARTHUR V DAVIS ACCOUNT DETAIL	0000		INV	05/23/2023	001112746 LINE AMOUNT		91210			
	1 00550126 6419			ATHLETICS OTHER PRO		100.00	100.00				
401246	ARTHUR V DAVIS ACCOUNT DETAIL	0000		INV	05/23/2023	001112755 LINE AMOUNT		91500			
	1 00550126 6419			ATHLETICS OTHER PRO		100.00	100.00				
				CHECK TOTAL			200.00				

Report generated: 05/18/2023 10:26:37
 User: Gloria James (glorja)
 Program ID: apwarrnt



City of Jackson

ACCOUNTS PAYABLE CHECK RUN REPORT

Detail Invoice List

CHECK RUN: CD052323 05/23/2023
 DUE DATE: 05/23/2023

CASH ACCOUNT:	999	1100	POOLED CASH - AP DISBURSEMENTS				AMOUNT	DOCUMENT	VOUCHER	CHECK
VENDOR	REMIT	PO	TYPE	DUE DATE	INVOICE	AMOUNT	DOCUMENT	VOUCHER	CHECK	
70455	AT & T MOBILITY		INV	05/23/2023	287303958429X0405202	91410				
	ACCOUNT DETAIL				LINE AMOUNT					
	1 00144170 6419		FIRE STAT OTHER PRO		1,373.05					
70455	AT & T MOBILITY		INV	05/23/2023	X05082023	91598				
	ACCOUNT DETAIL				LINE AMOUNT					
	1 18756520 6455		TRANSIT S CELLULAR P		1,130.74					
70455	AT & T MOBILITY		INV	05/23/2023	287318532892X0427223	91621				
	ACCOUNT DETAIL				LINE AMOUNT					
	1 00141110 6455		OFFICE OF CELLULAR P		111.69					
70455	AT & T MOBILITY		INV	05/23/2023	X04272023	91653				
	ACCOUNT DETAIL				LINE AMOUNT					
	2 18756520 6455		TRANSIT S CELLULAR P		954.11					
70455	AT & T MOBILITY		INV	05/23/2023	X05062023	91680				
	ACCOUNT DETAIL				LINE AMOUNT					
	1 18756520 6455		TRANSIT S CELLULAR P		3,217.71					
			CHECK TOTAL		6,787.30					
72672	AT&T		INV	05/23/2023	287309721006X032723	89635				
	ACCOUNT DETAIL				LINE AMOUNT					
	1 38271530 6455		CDBG CARECELLULAR P		164.92					
72672	AT&T		INV	05/09/2023	0277814634	90378				
	ACCOUNT DETAIL				LINE AMOUNT					
	1 00144310 6454		TELECOMMUTELPHONE		198.75					
	2 00144235 6454		PUBLIC SA TELEPHONE		28.18					
	3 03152135 6454		SUPPORT S TELEPHONE		1.83					
	3 00144220 6454									
72672	AT&T		INV	05/09/2023	0277965237	90380				
	ACCOUNT DETAIL				LINE AMOUNT					
	1 00144310 6454		TELECOMMUTELPHONE		162.19					
	2 00144235 6454		PUBLIC SA TELEPHONE		37.33					
	3 03152135 6454		O B CURTI TELEPHONE		0.26					
	4 00144220 6454		SUPPORT S TELEPHONE		2.41					

Report generated: 05/19/2023 10:26:37
 User: Gloria Jones (gloriaj)
 Program ID: apwarrnt

City of Jackson

ACCOUNTS PAYABLE CHECK RUN REPORT

Detail Invoice List

CHECK RUN: CD052323 05/23/2023
 DUE DATE: 05/23/2023



VENDOR	CASH ACCOUNT	1100	POOLED CASH - AP DISBURSEMENTS			INVOICE	AMOUNT	DOCUMENT	VOUCHER	CHECK
			REMIT	PO	TYPE	DUE DATE				
72672	AT&T		0000		INV	05/23/2023	287309721006X042723	202.19	91770	
ACCOUNT DETAIL							LINE AMOUNT			
1 38271530 6455							164.92			
CDBG CARESELLULAR P							CHECK TOTAL	164.92		
								760.79		
73286	AW REPORTING LLC		0000		INV	05/23/2023	102728		91659	
ACCOUNT DETAIL							LINE AMOUNT			
1 00140794 6414							810.54			
CLAIMS (O) SPECIAL L							CHECK TOTAL	810.54		
2196	B W I OF JACKSON INC		0000	23001213	INV	05/23/2023	17795425		91207	
ACCOUNT DETAIL							LINE AMOUNT			
1 39049800 6211							2,904.64			
2 39049800 6422							35.00			
ZOO PARK AGR1 + BOT							CHECK TOTAL	2,939.64		
ZOO PARK FREIGHT EX							CHECK TOTAL	2,939.64		
71770	BEN WIGGINS REMODELIN		0000		EFT	05/23/2023	2023-0015		91661	
ACCOUNT DETAIL							LINE AMOUNT			
1 08596430 6485							1,700.00			
2 08596440 6485							5,000.00			
3 08584510 6485							44,300.00			
4 08596410 6734							7,250.00			
LEAD INTR CONTRACT							CHECK TOTAL	58,250.00		
HEALTHY H CONTRACT							CHECK TOTAL	58,250.00		
LERP CONTRACT							CHECK TOTAL	58,250.00		
LEAD-BASE CONT-CITY							CHECK TOTAL	58,250.00		
71770	BEN WIGGINS REMODELIN		0000		EFT	05/23/2023	23-0014		91665	
ACCOUNT DETAIL							LINE AMOUNT			
1 08596430 6485							20,000.00			
2 08596440 6485							5,000.00			
3 08584510 6485							25,000.00			
4 08596410 6734							3,000.00			
LEAD INTR CONTRACT							CHECK TOTAL	53,000.00		
HEALTHY H CONTRACT							CHECK TOTAL	53,000.00		
LERP CONTRACT							CHECK TOTAL	53,000.00		
LEAD-BASE CONT-CITY							CHECK TOTAL	53,000.00		



3 Year ERP Solution

City of Jackson

ACCOUNTS PAYABLE CHECK RUN REPORT

Detail Invoice List

CHECK RUN: CD052323 05/23/2023
 DUE DATE: 05/23/2023

VENDOR	CASH ACCOUNT	999	1100	REMIT	PO	TYPE	DUE DATE	INVOICE	AMOUNT	DOCUMENT	VOUCHER	CHECK
401708	BERKSHIRE HATHAWAY SP			0000		INV	05/23/2023	05012023		91302		
	ACCOUNT DETAIL							LINE AMOUNT				
	1 05755870 6495							53,797.20	53,797.20			
								CHECK TOTAL	53,797.20			
66150	BIG 10 TIRES & ACCESS			0000	99230156	INV	05/23/2023	2083751		91371		
	ACCOUNT DETAIL							LINE AMOUNT				
	1 00550410 6464							400.69	400.69			
66150	BIG 10 TIRES & ACCESS			0000	99230156	INV	05/23/2023	2083665		91372		
	ACCOUNT DETAIL							LINE AMOUNT				
	1 00550410 6464							691.96	691.96			
66150	BIG 10 TIRES & ACCESS			0000	99230156	INV	05/23/2023	2083565		91373		
	ACCOUNT DETAIL							LINE AMOUNT				
	1 00945510 6316							90.99	90.99			
66150	BIG 10 TIRES & ACCESS			0000	99230156	INV	05/23/2023	2083632		91375		
	ACCOUNT DETAIL							LINE AMOUNT				
	1 00144240 6316							190.99	190.99			
66150	BIG 10 TIRES & ACCESS			0000	99230156	INV	05/23/2023	2083630		91376		
	ACCOUNT DETAIL							LINE AMOUNT				
	1 00144240 6316							441.98	441.98			
66150	BIG 10 TIRES & ACCESS			0000	99230156	INV	05/09/2023	2083536		91377		
	ACCOUNT DETAIL							LINE AMOUNT				
	1 00144240 6316							803.96	803.96			
66150	BIG 10 TIRES & ACCESS			0000	99230156	INV	05/23/2023	2083537		91378		
	ACCOUNT DETAIL							LINE AMOUNT				
	1 00144240 6316							1,007.96	1,007.96			

Report generated: 05/18/2023 10:26:37
 User: Gloria Jones (glorinj)
 Program ID: apwarml

City of Jackson



ACCOUNTS PAYABLE CHECK RUN REPORT

Detail Invoice List

CHECK RUN: CD052323 05/23/2023
 DUE DATE: 05/23/2023

CASH ACCOUNT: 999		1100		POOLED CASH - AP DISBURSEMENTS						
VENDOR	REMIT	PO	TYPE	DUE DATE	INVOICE	AMOUNT	DOCUMENT	VOUCHER	CHECK	
66150	0000	99230156	INV	05/23/2023	2083481					
BIG 10 TIRES & ACCESS										
ACCOUNT DETAIL										
1		00144240	6316							
OPERATION MOTOR VEH										
					2083513	763.96	91381			
LINE AMOUNT										
2083513										
LINE AMOUNT										
79.99										
CHECK TOTAL										
763.96										
66150	0000	99230156	INV	05/23/2023	2083535					
BIG 10 TIRES & ACCESS										
ACCOUNT DETAIL										
1		00145610	6316							
VEHICLE M MOTOR VEH										
					2083534	313.98	91382			
LINE AMOUNT										
2083534										
LINE AMOUNT										
784.95										
CHECK TOTAL										
6,199.37										
401728	0000	23001204	INV	05/23/2023	8009501					
BRADY INDUSTRIES LLC										
ACCOUNT DETAIL										
1		18756520	6213							
TRANSITS CLEANING &										
					8009501	684.65	90876			
LINE AMOUNT										
684.65										
CHECK TOTAL										
684.65										
401777	0000		INV	05/23/2023	0011122762					
BRENDEN JOHNSON										
ACCOUNT DETAIL										
1		00550126	6419							
ATHLETICS OTHER PRO										
					0011122762	132.00	91507			
LINE AMOUNT										
132.00										
CHECK TOTAL										
132.00										
400057	0000		INV	05/23/2023	0329238					
BRIGGS MARKETING INC										
ACCOUNT DETAIL										
1		00141110	6419							
OFFICE OF OTHER PRO										
					0329238	495.00	92154			
LINE AMOUNT										
495.00										
CHECK TOTAL										
495.00										

City of Jackson



ACCOUNTS PAYABLE CHECK RUN REPORT

Detail Invoice List

CHECK RUN: CD052323 05/23/2023
 DUE DATE: 05/23/2023

CASH ACCOUNT: 999		1100		POOLED CASH - AP DISBURSEMENTS											
VENDOR	64274	REMIT	PO	TYPE	DUE DATE	INVOICE	AMOUNT	DOCUMENT	VOUCHER	CHECK					
CANIZARO CAWTHON DAVI		0000		INV	05/23/2023	0015214		91884							
ACCOUNT DETAIL															
1 43040820 6419				2022 GO PL OTHER PROF			7,992.89								
CHECK TOTAL							7,992.89								
69303 CAPITAL CITY SECURITY		0000		EFT	05/23/2023	18869		90769							
ACCOUNT DETAIL															
1 00141510 6420				MCS ADMIN CONTRACT			1,108.60								
CHECK TOTAL							1,108.60								
3522 CAPITOL HARDWARE CO I		0000		INV	05/23/2023	207168		91512							
ACCOUNT DETAIL															
1 00490400 6461				77230536 COMPUTER BUILDINGS			1,120.00								
CHECK TOTAL							1,120.00								
401782 CARSON CONSULTING SER		0000		EFT	05/23/2023	502		91749							
ACCOUNT DETAIL															
1 07640145 6419				KELLOG OTHER PROF			3,333.33								
CHECK TOTAL							3,333.33								
72884 CATHOLIC CHARITIES IN		0000		EFT	05/23/2023	22023		91796							
ACCOUNT DETAIL															
1 08580812 6742				CC-JVS CNTRB OTH			416.06								
CHECK TOTAL							416.06								
72884 CATHOLIC CHARITIES IN		0000		EFT	05/23/2023	32023		91797							
ACCOUNT DETAIL															
1 08580812 6742				CC-JVS CNTRB OTH			2,497.28								
CHECK TOTAL							2,497.28								
72884 CATHOLIC CHARITIES IN		0000		EFT	05/23/2023	42023		91798							
ACCOUNT DETAIL															
1 08580812 6742				CC-JVS CNTRB OTH			3,352.04								
CHECK TOTAL							6,265.38								

Report generated: 05/18/2023 10:26:37
 User: Gloria Jones (gljahj)
 Program ID: apwarrml

City of Jackson



ACCOUNTS PAYABLE CHECK RUN REPORT

Detail Invoice List

CHECK RUN: CD052323 05/23/2023
 DUE DATE: 05/23/2023

CASH ACCOUNT	999	1100	REMIT	PO	TYPE	DUE DATE	INVOICE	AMOUNT	DOCUMENT	VOUCHER	CHECK
73523	CENTRAL NEBRASKA PACK		0000	23001156	INV	05/23/2023	036104		91203		
	ACCOUNT DETAIL						LINE AMOUNT				
	1 39049800	6214		ZOO PARK	FEED FOR A		3,884.14				
	2 39049800	6422		ZOO PARK	FREIGHT EX		1,072.93				
							CHECK TOTAL	4,957.07			
								4,957.07			
40789	CINTAS CORPORATION		0000		EFT	05/23/2023	4147383913		86618		
	ACCOUNT DETAIL						LINE AMOUNT				
	1 00146130	6516		P-W- PARK	UNIFORMS,		12.48				
								12.48			
									90895		
40789	CINTAS CORPORATION		0000		EFT	05/23/2023	4151617594				
	ACCOUNT DETAIL						LINE AMOUNT				
	1 00144160	6516		FIRE VEHI	UNIFORMS,		55.78				
								55.78			
									90896		
40789	CINTAS CORPORATION		0000		EFT	05/23/2023	4153012482				
	ACCOUNT DETAIL						LINE AMOUNT				
	1 00144160	6516		FIRE VEHI	UNIFORMS,		167.33				
								167.33			
									90897		
40789	CINTAS CORPORATION		0000		EFT	05/23/2023	4153012359				
	ACCOUNT DETAIL						LINE AMOUNT				
	1 00144160	6516		FIRE VEHI	UNIFORMS,		61.09				
								61.09			
									90900		
40789	CINTAS CORPORATION		0000		EFT	05/23/2023	4154415987				
	ACCOUNT DETAIL						LINE AMOUNT				
	1 00146130	6516		P-W- PARK	UNIFORMS,		24.96				
								24.96			
									91195		
40789	CINTAS CORPORATION		0000		EFT	05/23/2023	4154543112				
	ACCOUNT DETAIL						LINE AMOUNT				
	1 00145124	6516		SBD - PAV	UNIFORMS,		19.74				
								19.74			
									91197		
40789	CINTAS CORPORATION		0000		EFT	05/23/2023	4154543112				
	ACCOUNT DETAIL						LINE AMOUNT				
	1 00145124	6516		SBD - PAV	UNIFORMS,		95.04				
								95.04			

City of Jackson



ACCOUNTS PAYABLE CHECK RUN REPORT

Detail Invoice List

CHECK RUN: CD052323 05/23/2023
 DUE DATE: 05/23/2023

VENDOR	CASH ACCOUNT	999	1100	REMIT	PO	TYPE	DUE DATE	INVOICE	AMOUNT	DOCUMENT	VOUCHER	CHECK
40789	CINTAS CORPORATION			0000		EFT	05/23/2023	4154543103	95.04	91201		
	ACCOUNT DETAIL							LINE AMOUNT				
		1	03152215			MAINTENAN UNIFORMS,		15.68				
40789	CINTAS CORPORATION			0000		EFT	05/23/2023	4154543088	15.68	91202		
	ACCOUNT DETAIL							LINE AMOUNT				
		1	03152215			MAINTENAN UNIFORMS,		53.43				
40789	CINTAS CORPORATION			0000		EFT	05/23/2023	4154557510	53.43	91278		
	ACCOUNT DETAIL							LINE AMOUNT				
		1	00145700			CUSTODIAL UNIFORMS,		178.75				
40789	CINTAS CORPORATION			0000		EFT	05/23/2023	4154557549	178.75	91279		
	ACCOUNT DETAIL							LINE AMOUNT				
		1	00145300			CARE & MA UNIFORMS,		125.82				
40789	CINTAS CORPORATION			0000		EFT	05/23/2023	4154416319	125.82	91380		
	ACCOUNT DETAIL							LINE AMOUNT				
		1	00950610			LANDFILL UNIFORMS,		106.35				
40789	CINTAS CORPORATION			0000		EFT	05/23/2023	4154543179	106.35	91570		
	ACCOUNT DETAIL							LINE AMOUNT				
		1	03152220			OPERATION UNIFORMS,		214.71				
40789	CINTAS CORPORATION			0000		EFT	05/23/2023	4155109944	214.71	91578		
	ACCOUNT DETAIL							LINE AMOUNT				
		1	00146130			P.W. PARK UNIFORMS,		23.65				
40789	CINTAS CORPORATION			0000		EFT	05/23/2023	4155249997	23.65	91597		
	ACCOUNT DETAIL							LINE AMOUNT				
		1	00145124			SBD - PAV UNIFORMS,		37.56				
40789	CINTAS CORPORATION			0000		EFT	05/23/2023	4155250207	37.56	91609		
	ACCOUNT DETAIL							LINE AMOUNT				
		1	00145124			SBD - PAV UNIFORMS,		95.04				

Report generated: 05/18/2023 10:28:37
 User: Gloria Jones (glorajj)
 Program ID: apwarrnl

City of Jackson



ACCOUNTS PAYABLE CHECK RUN REPORT

Detail Invoice List

CHECK RUN: CD052323 05/23/2023
 DUE DATE: 05/23/2023

CASH ACCOUNT: 999		1100		POOLED CASH - AP DISBURSEMENTS										
VENDOR		REMIT	PO	TYPE	DUE DATE	INVOICE	AMOUNT	DOCUMENT	VOUCHER	CHECK				
40789	CINTAS CORPORATION ACCOUNT DETAIL	0000		EFT	05/23/2023	4155265841		91824						
	1 00145700 6516					LINE AMOUNT	178.75							
40789	CINTAS CORPORATION ACCOUNT DETAIL	0000		EFT	05/23/2023	4155265882		91626						
	1 00145300 6516					LINE AMOUNT	125.82							
40789	CINTAS CORPORATION ACCOUNT DETAIL	0000		EFT	05/23/2023	4155260268		91646						
	1 03152215 6516					LINE AMOUNT	69.17							
40789	CINTAS CORPORATION ACCOUNT DETAIL	0000		EFT	05/23/2023	4155250257		91647						
	1 03152215 6516					LINE AMOUNT	15.68							
40789	CINTAS CORPORATION ACCOUNT DETAIL	0000		EFT	05/23/2023	4155250998		91657						
	1 00144810 6516					LINE AMOUNT	123.32							
40789	CINTAS CORPORATION ACCOUNT DETAIL	0000		EFT	05/23/2023	4155250423		91683						
	1 03152220 6516					LINE AMOUNT	214.71							
40789	CINTAS CORPORATION ACCOUNT DETAIL	0000		EFT	05/23/2023	4155110522		91778						
	1 00950610 6516					LINE AMOUNT	106.35							
40789	CINTAS CORPORATION ACCOUNT DETAIL	0000		EFT	05/23/2023	4155250675		91782						
	1 00145125 6516					LINE AMOUNT	190.00							
40789	CINTAS CORPORATION ACCOUNT DETAIL	0000		EFT	05/23/2023	4154543359		91878						
	1 00145125 6516					LINE AMOUNT	190.00							

Report generated: 05/18/2023 10:26:37
 User: Gloria Jones (gloriej)
 Program ID: apwarml



City of Jackson

ACCOUNTS PAYABLE CHECK RUN REPORT

Detail Invoice List

CHECK RUN: CD052323 05/23/2023
 DUE DATE: 05/23/2023

CASH ACCOUNT	999	1100	REMIT	PO	TYPE	DUE DATE	INVOICE	AMOUNT	DOCUMENT	VOUCHER	CHECK
VENDOR	40789	CINTAS CORPORATION	0000		EFT	05/23/2023	4153826770		91879		
		ACCOUNT DETAIL					LINE AMOUNT				
		1 00145125 6516		SBD - D	UNIFORMS,		232.53				
							CHECK TOTAL	232.53			
								2,789.52			
60900		CLARKE POWER SERVICES	0000	99230169	INV	05/23/2023	S108027601:01		91394		
		ACCOUNT DETAIL					LINE AMOUNT				
		1 00950610 6316		LANDFILL	MOTOR VEH		3,359.95				
							CHECK TOTAL	3,359.95			
60900		CLARKE POWER SERVICES	0000	99230169	INV	05/23/2023	S108027348:01		91395		
		ACCOUNT DETAIL					LINE AMOUNT				
		1 00950610 6316		LANDFILL	MOTOR VEH		1,341.46				
							CHECK TOTAL	1,341.46			
60900		CLARKE POWER SERVICES	0000	99230214	INV	05/23/2023	S108027259:01		91396		
		ACCOUNT DETAIL					LINE AMOUNT				
		1 00145125 6316		SBD - D	MOTOR VEH		1,133.62				
							CHECK TOTAL	1,133.62			
60900		CLARKE POWER SERVICES	0000	99230214	INV	05/09/2023	S108027311:01		91397		
		ACCOUNT DETAIL					LINE AMOUNT				
		1 00950610 6316		LANDFILL	MOTOR VEH		608.00				
							CHECK TOTAL	608.00			
60900		CLARKE POWER SERVICES	0000	99230214	INV	05/23/2023	S108027348		91398		
		ACCOUNT DETAIL					LINE AMOUNT				
		1 00950610 6316		LANDFILL	MOTOR VEH		447.48				
							CHECK TOTAL	447.48			
60900		CLARKE POWER SERVICES	0000	99230214	INV	05/23/2023	S108027259:01		91399		
		ACCOUNT DETAIL					LINE AMOUNT				
		1 00145125 6316		PUBLIC DE	SPECIAL L		15,000.00				
							CHECK TOTAL	15,000.00			
401475		CONSULTING BY LEE	0000	KELLOG	OTHER PROF	05/23/2023	017		91613		
		ACCOUNT DETAIL					LINE AMOUNT				
		1 07640145 6419					2,708.34				
							CHECK TOTAL	2,708.34			

City of Jackson



ACCOUNTS PAYABLE CHECK RUN REPORT

Detail Invoice List

CHECK RUN: CD052323 05/23/2023
 DUE DATE: 05/23/2023

VENDOR	CASH ACCOUNT	999	1100	REMIT	PO	TYPE	DUE DATE	INVOICE	AMOUNT	DOCUMENT	VOUCHER	CHECK
43968	CRAFT OFFICE PLUS LLC			0000		INV	05/23/2023	20434	89756			
	ACCOUNT DETAIL											
	1 00142800 6218					MUNI CLRK OFFICE SUP		35.58	35.58			
						CHECK TOTAL			35.58			
71086	CSL SERVICES INC			0000		INV	05/23/2023	JBN 22-07	91580			
	ACCOUNT DETAIL											
	1 03152210 6419					ADMINISTR OTHER PRO		5,872.00	5,872.00			
						CHECK TOTAL			15,604.00			
71086	CSL SERVICES INC			0000		INV	05/23/2023	WBIFM 22-07	91581			
	ACCOUNT DETAIL											
	1 03152210 6419					ADMINISTR OTHER PRO		15,604.00	15,604.00			
						CHECK TOTAL			21,476.00			
71998	CSPIRE BUSINESS SOLUT			0000		INV	05/23/2023	30004919890323	88654			
	ACCOUNT DETAIL											
	1 00142630 6455					BUSINESS CELLULAR P		377.63	377.63			
	2 00144470 6455					COMMUNITYCELLULAR P		240.31	240.31			
	3 00144410 6455					ADMINISTR CELLULAR P		411.96	411.96			
						CHECK TOTAL			1,029.90			
71998	CSPIRE BUSINESS SOLUT			0000		INV	05/23/2023	30004919890423	91393			
	ACCOUNT DETAIL											
	1 00140440 6455					RENTAL&RECELLULAR P		377.63	377.63			
	2 00144410 6455					ADMINISTR CELLULAR P		411.96	411.96			
	3 00144470 6455					COMMUNITYCELLULAR P		239.41	239.41			
						CHECK TOTAL			1,029.00			
4800	CUMMINS MID SOUTH INC			0000		INV	05/23/2023	C6-44972	91663			
	ACCOUNT DETAIL											
	1 00144120 6316					EMERGENCMOTOR VEH		141.87	141.87			
						CHECK TOTAL			141.87			

Report generated: 05/18/2023 10:26:37
 User: Gloria Jones (gforal)
 Program ID: apwerrn1

City of Jackson



ACCOUNTS PAYABLE CHECK RUN REPORT

Detail Invoice List

CHECK RUN: CD052323 05/23/2023
 DUE DATE: 05/23/2023

CASH ACCOUNT:	999	1100	REMIT	PO	TYPE	DUE DATE	INVOICE	AMOUNT	DOCUMENT	VOUCHER	CHECK
4800	CUMMINS MID SOUTH INC	0000	88230189	INV	05/23/2023	C6-45119	269.95	91670			
	ACCOUNT DETAIL										
	1 00144120 6316			EMERGENCMOTOR VEH			269.95				
4800	CUMMINS MID SOUTH INC	0000	88230189	INV	05/23/2023	C6-45124	941.93	91676			
	ACCOUNT DETAIL										
	1 00144120 6316			EMERGENCMOTOR VEH			941.93				
4800	CUMMINS MID SOUTH INC	0000	88230195	INV	05/23/2023	C6-45254	163.88	91676			
	ACCOUNT DETAIL										
	1 00144120 6316			EMERGENCMOTOR VEH			163.88				
				CHECK TOTAL			1,517.63				
42896	CUSTOM PRODUCTS CORPO	0000	23001228	INV	05/23/2023	391188	1,340.00	91712			
	ACCOUNT DETAIL										
	1 03152220 6299			OPERATION OTHER OPE			1,340.00				
				CHECK TOTAL			1,340.00				
401385	DAVIS REFRIGERATION &	0000	23000534	INV	05/23/2023	121522	4,500.00	90868			
	ACCOUNT DETAIL										
	1 40450133 6240			DFA-PETEBRONN-CAPITA			4,500.00				
				CHECK TOTAL			4,500.00				
71851	DELTA DENTAL INSURANC	0000		EFT	05/23/2023	BE005484225	52,926.93	91291			
	ACCOUNT DETAIL										
	1 057 2102			EMPLOYEESACCOUNTS			52,926.93				
				CHECK TOTAL			52,926.93				
59412	DEVINEY EQUIPMENT	0000	23001016	INV	05/23/2023	IV62481	46.26	87714			
	ACCOUNT DETAIL										
	1 00550410 6422			PARKS - M FREIGHT E			46.26				
	2 00550410 6464			PARKS - M MACHINE/E			240.24				
				CHECK TOTAL			286.50				

Report generated: 05/18/2023 10:26:37
 User: Gloria Jones (glorj) apwarrrl
 Program ID:

City of Jackson



ACCOUNTS PAYABLE CHECK RUN REPORT

Detail Invoice List

CHECK RUN: CD052323 05/23/2023
 DUE DATE: 05/23/2023

CASH ACCOUNT	999	1100	POOLED CASH - AP DISBURSEMENTS				INVOICE	AMOUNT	DOCUMENT	VOUCHER	CHECK
VENDOR	REMIT	PO	TYPE	DUE DATE	INVOICE	AMOUNT	DOCUMENT	VOUCHER	CHECK		
59412	DEVINEY EQUIPMENT	23001131	INV	05/23/2023	IV63051		90805				
	ACCOUNT DETAIL				LINE AMOUNT						
	1 00550410 6317		PARKS - M OTHER REP		358.12						
	2 00550410 6422		PARKS - M FREIGHT E		26.84						
						384.96					
59412	DEVINEY EQUIPMENT	99230222	INV	05/23/2023	WO56997		91572				
	ACCOUNT DETAIL				LINE AMOUNT						
	1 03152220 6465		OPERATION AUTO + TR		4,412.60						
59412	DEVINEY EQUIPMENT	99230222	INV	05/23/2023	IV62464		91573				
	ACCOUNT DETAIL				LINE AMOUNT						
	1 00144240 6316		OPERATION MOTOR VEH		440.80						
						440.80					
59412	DEVINEY EQUIPMENT	99230221	INV	05/23/2023	WO56975		91574				
	ACCOUNT DETAIL				LINE AMOUNT						
	1 03152220 6465		OPERATION AUTO + TR		3,722.70						
						3,722.70					
59412	DEVINEY EQUIPMENT	99230221	INV	05/23/2023	WO57145		91575				
	ACCOUNT DETAIL				LINE AMOUNT						
	1 03152220 6465		OPERATION AUTO + TR		1,141.16						
						1,141.16					
59412	DEVINEY EQUIPMENT	99230113	INV	05/23/2023	IV62604		91714				
	ACCOUNT DETAIL				LINE AMOUNT						
	1 00145125 6316		SBD - D MOTOR VEH		1,366.02						
						1,366.02					
59412	DEVINEY EQUIPMENT	99230113	INV	05/23/2023	IV62665		91715				
	ACCOUNT DETAIL				LINE AMOUNT						
	1 00145125 6316		SBD - D MOTOR VEH		338.15						
						338.15					
59412	DEVINEY EQUIPMENT	99230113	INV	05/23/2023	WO57146		91716				
	ACCOUNT DETAIL				LINE AMOUNT						
	1 03152220 6465		OPERATION AUTO + TR		1,241.17						
						1,241.17					
					CHECK TOTAL	13,334.06					
401745	DG MORRISON INC	22002003	INV	05/23/2023	CS/2023/8872		91702				
	ACCOUNT DETAIL				LINE AMOUNT						
	1 40450133 6240		DFA-PETE/BRNON-CAPITA		4,996.00						

City of Jackson



ACCOUNTS PAYABLE CHECK RUN REPORT

Detail Invoice List

CHECK RUN: CD052323 05/23/2023
 DUE DATE: 05/23/2023

VENDOR	CASH ACCOUNT	999	1100	REMIT	PO	TYPE	DUE DATE	INVOICE	AMOUNT	DOCUMENT	VOUCHER	CHECK
73505	DOXIM UTILTEC LLC			0000		INV	05/23/2023	0423P				
	ACCOUNT DETAIL											
	1 03152010 6421											
									21,650.15	91733		
									4,996.00			
									4,996.00			
73505	DOXIM UTILTEC LLC			0000		INV	05/23/2023	INV019225				
	ACCOUNT DETAIL											
	1 03152010 6421											
									9,348.34	91735		
									30,998.49			
69111	DUNCAN PARKING TECH I			0000		INV	05/23/2023	DPT04724				
	ACCOUNT DETAIL											
	1 00146130 6240											
									351.00	90822		
									351.00			
69111	DUNCAN PARKING TECH I			0000		INV	05/23/2023	DPT045735				
	ACCOUNT DETAIL											
	1 00146130 6240											
									36.00	90841		
									36.00			
400234	ECOLANE USA INC			0000		INV	05/23/2023	CINV-030401				
	ACCOUNT DETAIL											
	1 18756520 6231											
									39,999.00	91338		
									39,999.00			
400234	ECOLANE USA INC			0000		INV	05/23/2023	CINV-028466				
	ACCOUNT DETAIL											
	1 18756520 6231											
									74,778.00			
									65,551.37			
									140,329.37			
									180,328.37			

Report generated: 05/18/2023 10:26:37
 User: Gloria Jones (gloriaj)
 Program ID: apwarrn

City of Jackson



ACCOUNTS PAYABLE CHECK RUN REPORT

Detail Invoice List

CHECK RUN: CD052323 05/23/2023
 DUE DATE: 05/23/2023

CASH ACCOUNT: 999		1100		POOLED CASH - AP DISBURSEMENTS									
VENDOR	REMIT	PO	TYPE	DUE DATE	INVOICE	AMOUNT	DOCUMENT	VOUCHER	CHECK				
70982	EMERGENCY EQUIPMENT P	88230186	EFT	05/23/2023	482346		91664						
	ACCOUNT DETAIL				LINE AMOUNT								
	1 00144120 6316		EMERGENCMOTOR VEH		1,323.25								
70982	EMERGENCY EQUIPMENT P	88230186	EFT	05/23/2023	482347		91666						
	ACCOUNT DETAIL				LINE AMOUNT								
	1 00144120 6316		EMERGENCMOTOR VEH		84.08								
70982	EMERGENCY EQUIPMENT P	88230188	EFT	05/23/2023	482402		91667						
	ACCOUNT DETAIL				LINE AMOUNT								
	1 00144120 6316		EMERGENCMOTOR VEH		2,307.02								
					CHECK TOTAL	3,714.35							
20377	ENTERGY		INV	05/23/2023	1045813688052323		91896						
	ACCOUNT DETAIL				LINE AMOUNT								
	1 00145400 6451		STREET LI ELECTRIC L		114.72								
20377	ENTERGY		INV	05/23/2023	107755514052323		91897						
	ACCOUNT DETAIL				LINE AMOUNT								
	1 00145300 6451		CARE & MA ELECTRIC L		13.35								
20377	ENTERGY		INV	05/23/2023	109160960052323		91898						
	ACCOUNT DETAIL				LINE AMOUNT								
	1 00145400 6451		STREET LI ELECTRIC L		27.42								
20377	ENTERGY		INV	05/23/2023	110002342052323		91899						
	ACCOUNT DETAIL				LINE AMOUNT								
	1 00144820 6451		TRAFFIC S ELECTRIC L		27.42								
20377	ENTERGY		INV	05/23/2023	110002425052323		91900						
	ACCOUNT DETAIL				LINE AMOUNT								
	1 00144820 6451		TRAFFIC S ELECTRIC L		27.42								
20377	ENTERGY		INV	05/23/2023	110041514052323		91901						
	ACCOUNT DETAIL				LINE AMOUNT								
	1 00144820 6451		TRAFFIC S ELECTRIC L		36.25								

Report generated: 05/18/2023 10:26:37
 User: Gloria Jones (gloriaj)
 Program ID: apwarrrt



City of Jackson

ACCOUNTS PAYABLE CHECK RUN REPORT

Detail Invoice List

CHECK RUN: CD052323 05/23/2023
 DUE DATE: 05/23/2023

VENDOR	CASH ACCOUNT	999	1100	REMIT	PO	TYPE	DUE DATE	INVOICE	AMOUNT	DOCUMENT	VOUCHER	CHECK
20377	ENTERGY			0000		INV	05/23/2023	110041522052323		91902		
								LINE AMOUNT				
								27.42				
20377	ENTERGY			0000		INV	05/23/2023	112369830052323		91903		
								LINE AMOUNT				
								27.42				
20377	ENTERGY			0000		INV	05/23/2023	115118317052323		91904		
								LINE AMOUNT				
								35.30				
20377	ENTERGY			0000		INV	05/23/2023	116301771052323		91905		
								LINE AMOUNT				
								44.17				
20377	ENTERGY			0000		INV	05/23/2023	116301805052323		91906		
								LINE AMOUNT				
								27.42				
20377	ENTERGY			0000		INV	05/23/2023	116301896052323		91907		
								LINE AMOUNT				
								30.11				
20377	ENTERGY			0000		INV	05/23/2023	116302118052323		91908		
								LINE AMOUNT				
								28.37				
20377	ENTERGY			0000		INV	05/23/2023	116302142052323		91909		
								LINE AMOUNT				
								27.42				
20377	ENTERGY			0000		INV	05/23/2023	116302167052323		91910		
								LINE AMOUNT				
								96.08				
20377	ENTERGY			0000		INV	05/23/2023	116302167052323		91910		
								LINE AMOUNT				
								27.42				

Report generated: 05/18/2023 10:26:37
 User: Gloria Jones (glorjaj)
 Program ID: apwerrml

City of Jackson



ACCOUNTS PAYABLE CHECK RUN REPORT

Detail Invoice List

CHECK RUN: CD052323 05/23/2023
 DUE DATE: 05/23/2023

CASH ACCOUNT: 999		1100		POOLED CASH - AP DISBURSEMENTS						
VENDOR	REMIT	PO	TYPE	DUE DATE	INVOICE	AMOUNT	DOCUMENT	VOUCHER	CHECK	
20377	ENTERGY		INV	05/23/2023	116302175052323		91911			
	ACCOUNT DETAIL				LINE AMOUNT					
	1 03152010 6451		WATER/SEW/ELECTRIC L		27.42	27.42				
20377	ENTERGY		INV	05/23/2023	116302191052323		91912			
	ACCOUNT DETAIL				LINE AMOUNT					
	1 03152010 6451		WATER/SEW/ELECTRIC L		27.42	27.42				
20377	ENTERGY		INV	05/23/2023	116302431052323		91913			
	ACCOUNT DETAIL				LINE AMOUNT					
	1 03152010 6451		WATER/SEW/ELECTRIC L		29.00	29.00				
20377	ENTERGY		INV	05/23/2023	116434671052323		91914			
	ACCOUNT DETAIL				LINE AMOUNT					
	1 00145400 6451		STREET LI ELECTRIC L		66.11	66.11				
20377	ENTERGY		INV	05/23/2023	116434689052323		91915			
	ACCOUNT DETAIL				LINE AMOUNT					
	1 03152010 6451		WATER/SEW/ELECTRIC L		163.70	163.70				
20377	ENTERGY		INV	05/23/2023	116434705052323		91916			
	ACCOUNT DETAIL				LINE AMOUNT					
	1 00145400 6451		STREET LI ELECTRIC L		164.22	164.22				
20377	ENTERGY		INV	05/23/2023	116434713052323		91917			
	ACCOUNT DETAIL				LINE AMOUNT					
	1 00145400 6451		STREET LI ELECTRIC L		122.02	122.02				
20377	ENTERGY		INV	05/23/2023	116434721052323		91918			
	ACCOUNT DETAIL				LINE AMOUNT					
	1 00145400 6451		STREET LI ELECTRIC L		81.43	81.43				
20377	ENTERGY		INV	05/23/2023	118974476052323		91921			
	ACCOUNT DETAIL				LINE AMOUNT					
	1 00145400 6451		STREET LI ELECTRIC L		83.95	83.95				



City of Jackson

ACCOUNTS PAYABLE CHECK RUN REPORT

Detail Invoice List

CHECK RUN: CD052323 05/23/2023
 DUE DATE: 05/23/2023

CASH ACCOUNT: 999		1100		POOLED CASH - AP DISBURSEMENTS										
VENDOR	REMIT	PO	TYPE	DUE DATE	INVOICE	AMOUNT	DOCUMENT	VOUCHER	CHECK					
20377	ENTERGY		INV	05/23/2023	121079818052323		91923							
	ACCOUNT DETAIL				LINE AMOUNT	86.30								
	1 00145400 6451		STREET LI ELECTRIC L											
20377	ENTERGY		INV	05/23/2023	121079826052323		91924							
	ACCOUNT DETAIL				LINE AMOUNT	80.00								
	1 00145400 6451		STREET LI ELECTRIC L											
20377	ENTERGY		INV	05/23/2023	121230528052323		91925							
	ACCOUNT DETAIL				LINE AMOUNT	99.73								
	1 00145400 6451		STREET LI ELECTRIC L											
20377	ENTERGY		INV	05/23/2023	121230551052323		91926							
	ACCOUNT DETAIL				LINE AMOUNT	64.04								
	1 00145400 6451		STREET LI ELECTRIC L											
20377	ENTERGY		INV	05/23/2023	121230569052323		91927							
	ACCOUNT DETAIL				LINE AMOUNT	52.39								
	1 00145400 6451		STREET LI ELECTRIC L											
20377	ENTERGY		INV	05/23/2023	126131630052323		91928							
	ACCOUNT DETAIL				LINE AMOUNT	39.74								
	1 00145400 6451		STREET LI ELECTRIC L											
20377	ENTERGY		INV	05/23/2023	133471136052323		91930							
	ACCOUNT DETAIL				LINE AMOUNT	53.48								
	1 00145400 6451		STREET LI ELECTRIC L											
20377	ENTERGY		INV	05/23/2023	14866974052323		91931							
	ACCOUNT DETAIL				LINE AMOUNT	198.39								
	1 00550125 6451		PROGRAMMELECTRIC L											
20377	ENTERGY		INV	05/23/2023	15045388052323		91932							
	ACCOUNT DETAIL				LINE AMOUNT	5,266.75								
	1 00145300 6451		CARE & MA ELECTRIC L											

Report generated: 05/18/2023 10:26:37
 User: Gloria Jones (gloriaj)
 Program ID: apwrrnl

City of Jackson



ACCOUNTS PAYABLE CHECK RUN REPORT

Detail Invoice List

CHECK RUN: CD052323 05/23/2023
 DUE DATE: 05/23/2023

CASH ACCOUNT: 999		1100		POOLED CASH - AP DISBURSEMENTS						
VENDOR	REMT	PO	TYPE	DUE DATE	INVOICE	AMOUNT	DOCUMENT	VOUCHER	CHECK	
20377	ENTERGY		INV	05/23/2023	15118664052323		91933			
	ACCOUNT DETAIL				LINE AMOUNT					
	1 03152130 6451		FEWELL WT ELECTRIC L		27.42	27.42				
20377	ENTERGY		INV	05/23/2023	15681497052323		91935			
	ACCOUNT DETAIL				LINE AMOUNT					
	1 00950610 6451		LANDFILL ELECTRIC L		654.87	654.87				
20377	ENTERGY		INV	05/23/2023	15681984052323		91936			
	ACCOUNT DETAIL				LINE AMOUNT					
	1 00145400 6451		STREET LI ELECTRIC L		27.57	27.57				
20377	ENTERGY		INV	05/23/2023	16008930052323		91941			
	ACCOUNT DETAIL				LINE AMOUNT					
	1 00145400 6451		STREET LI ELECTRIC L		133.86	133.86				
20377	ENTERGY		INV	05/23/2023	16009169052323		91942			
	ACCOUNT DETAIL				LINE AMOUNT					
	1 00144170 6451		FIRE STAT ELECTRIC L		513.39	513.39				
20377	ENTERGY		INV	05/23/2023	16108474052323		91945			
	ACCOUNT DETAIL				LINE AMOUNT					
	1 00145400 6451		STREET LI ELECTRIC L		171.53	171.53				
20377	ENTERGY		INV	05/23/2023	16119380052323		91946			
	ACCOUNT DETAIL				LINE AMOUNT					
	1 00144170 6451		FIRE STAT ELECTRIC L		27.42	27.42				
20377	ENTERGY		INV	05/23/2023	16151102052323		91948			
	ACCOUNT DETAIL				LINE AMOUNT					
	1 00145300 6451		CARE & MA ELECTRIC L		5,647.99	5,647.99				
20377	ENTERGY		INV	05/23/2023	16242960052323		91950			
	ACCOUNT DETAIL				LINE AMOUNT					
	1 00144310 6451		TELECOMMUNELECTRIC L		4,171.99	4,171.99				

City of Jackson



ACCOUNTS PAYABLE CHECK RUN REPORT

Detail Invoice List

CHECK RUN: CD052323 05/23/2023
 DUE DATE: 05/23/2023

CASH ACCOUNT: 999		1100		POOLED CASH - AP DISBURSEMENTS				INVOICE	AMOUNT	DOCUMENT	VOUCHER	CHECK
VENDOR	REMIT	PO	TYPE	DUE DATE	INVOICE	AMOUNT	DOCUMENT	VOUCHER	CHECK			
20377	ENTERGY		INV	05/23/2023	163621931052323		91951					
	ACCOUNT DETAIL				LINE AMOUNT							
	1 00145300 6451		CARE & MA ELECTRIC L		2,348.23	2,348.23						
20377	ENTERGY		INV	05/23/2023	16365363052323		91952					
	ACCOUNT DETAIL				LINE AMOUNT							
	1 17494400 6451		MADISON S ELECTRIC L		27.42	27.42						
20377	ENTERGY		INV	05/23/2023	16365520052323		91953					
	ACCOUNT DETAIL				LINE AMOUNT							
	1 17494400 6451		MADISON S ELECTRIC L		11.81	11.81						
20377	ENTERGY		INV	05/23/2023	164129611052323		91955					
	ACCOUNT DETAIL				LINE AMOUNT							
	1 00144170 6451		FIRE STAT ELECTRIC L		48.06	48.06						
20377	ENTERGY		INV	05/23/2023	16488769052323		91957					
	ACCOUNT DETAIL				LINE AMOUNT							
	1 00550140 6451		TENNIS CO ELECTRIC L		2,048.26	2,048.26						
20377	ENTERGY		INV	05/23/2023	16488975052323		91958					
	ACCOUNT DETAIL				LINE AMOUNT							
	1 00144170 6451		FIRE STAT ELECTRIC L		1,024.54	1,024.54						
20377	ENTERGY		INV	05/23/2023	16547283052323		91959					
	ACCOUNT DETAIL				LINE AMOUNT							
	1 00144170 6451		FIRE STAT ELECTRIC L		50.61	50.61						
20377	ENTERGY		INV	05/23/2023	16548422052323		91960					
	ACCOUNT DETAIL				LINE AMOUNT							
	1 00144170 6451		FIRE STAT ELECTRIC L		758.99	758.99						
20377	ENTERGY		INV	05/23/2023	165831546052323		91961					
	ACCOUNT DETAIL				LINE AMOUNT							
	1 00145400 6451		STREET LI ELECTRIC L		84.64	84.64						

Report generated: 05/18/2023 10:26:37
 User: Gloria Jones (gjohnj)
 Program ID: apwarrnl

City of Jackson



ACCOUNTS PAYABLE CHECK RUN REPORT

Detail Invoice List

CHECK RUN: CD052323 05/23/2023
 DUE DATE: 05/23/2023

CASH ACCOUNT: 999		1100		POOLED CASH - AP DISBURSEMENTS						
VENDOR	ENTERGY	REMIT	PO	TYPE	DUE DATE	INVOICE	AMOUNT	DOCUMENT	VOUCHER	CHECK
20377	ENTERGY	0000		INV	05/23/2023	16664021052323		91963		
	ACCOUNT DETAIL					LINE AMOUNT				
	1 00144220 6451			SUPPORT S ELECTRIC L		159.32	159.32			
20377	ENTERGY	0000		INV	05/23/2023	16666216052323		91965		
	ACCOUNT DETAIL					LINE AMOUNT				
	1 00550410 6451			PARKS - M ELECTRIC L		32.27	32.27			
20377	ENTERGY	0000		INV	05/23/2023	16745341052323		91970		
	ACCOUNT DETAIL					LINE AMOUNT				
	1 00144170 6451			FIRE STAT ELECTRIC L		359.26	359.26			
20377	ENTERGY	0000		INV	05/23/2023	16745614052323		91971		
	ACCOUNT DETAIL					LINE AMOUNT				
	1 00145400 6451			STREET LI ELECTRIC L		89.59	89.59			
20377	ENTERGY	0000		INV	05/23/2023	16745846052323		91972		
	ACCOUNT DETAIL					LINE AMOUNT				
	1 00550460 6451			PARKS - BA ELECTRIC L		240.59	240.59			
20377	ENTERGY	0000		INV	05/23/2023	171330426052323		91978		
	ACCOUNT DETAIL					LINE AMOUNT				
	1 00144220 6451			SUPPORT S ELECTRIC L		73.04	73.04			
20377	ENTERGY	0000		INV	05/23/2023	17542267052323		91983		
	ACCOUNT DETAIL					LINE AMOUNT				
	1 00140700 6451			LEGAL ELECTRIC L		1,375.51	1,375.51			
20377	ENTERGY	0000		INV	05/23/2023	17840760052323		91986		
	ACCOUNT DETAIL					LINE AMOUNT				
	1 00550180 6451			AQUATICS ELECTRIC L		127.03	127.03			
20377	ENTERGY	0000		INV	05/23/2023	18027151052323		91992		
	ACCOUNT DETAIL					LINE AMOUNT				
	1 00144170 6451			FIRE STAT ELECTRIC L		412.80	412.80			



City of Jackson

ACCOUNTS PAYABLE CHECK RUN REPORT

Detail Invoice List

CHECK RUN: CD052323 05/23/2023
 DUE DATE: 05/23/2023

CASH ACCOUNT: 999		1100		POOLED CASH - AP DISBURSEMENTS						
VENDOR	ENTERGY	REMIT	PO	TYPE	DUE DATE	INVOICE	AMOUNT	DOCUMENT	VOUCHER	CHECK
20377	ENTERGY	0000		INV	05/23/2023	18027375052323		91993		
	ACCOUNT DETAIL					LINE AMOUNT				
	1 00144170 6451			FIRE STAT ELECTRIC L		536.11				
20377	ENTERGY	0000		INV	05/23/2023	18258616052323		91995		
	ACCOUNT DETAIL					LINE AMOUNT				
	1 00144170 6451			FIRE STAT ELECTRIC L		775.35				
20377	ENTERGY	0000		INV	05/23/2023	18291369052323		91997		
	ACCOUNT DETAIL					LINE AMOUNT				
	1 00144170 6451			FIRE STAT ELECTRIC L		361.16				
20377	ENTERGY	0000		INV	05/23/2023	18292896052323		91998		
	ACCOUNT DETAIL					LINE AMOUNT				
	1 00550180 6451			AQUATICS ELECTRIC L		27.42				
20377	ENTERGY	0000		INV	05/23/2023	18546085052323		92000		
	ACCOUNT DETAIL					LINE AMOUNT				
	1 00550460 6451			PARKS -BA ELECTRIC L		27.42				
20377	ENTERGY	0000		INV	05/23/2023	18546333052323		92001		
	ACCOUNT DETAIL					LINE AMOUNT				
	1 00550460 6451			PARKS -BA ELECTRIC L		27.42				
20377	ENTERGY	0000		INV	05/23/2023	18624239052323		92002		
	ACCOUNT DETAIL					LINE AMOUNT				
	1 00144170 6451			FIRE STAT ELECTRIC L		1,065.23				
20377	ENTERGY	0000		INV	05/23/2023	18624445052323		92003		
	ACCOUNT DETAIL					LINE AMOUNT				
	1 00149100 6451			MUNICIPAL ELECTRIC L		424.09				
20377	ENTERGY	0000		INV	05/23/2023	18625301052323		92004		
	ACCOUNT DETAIL					LINE AMOUNT				
	1 00145300 6451			CARE & MA ELECTRIC L		16,733.48				

City of Jackson

ACCOUNTS PAYABLE CHECK RUN REPORT

Detail Invoice List

CHECK RUN: CD052323 05/23/2023
 DUE DATE: 05/23/2023



CASH/ACCOUNT:		999 1100		POOLED CASH - AP DISBURSEMENTS							
VENDOR	REMIT	PO	TYPE	DUE DATE	INVOICE	AMOUNT	DOCUMENT	VOUCHER	CHECK		
20377	ENTERGY		INV	05/23/2023	19108414052323						
	ACCOUNT DETAIL				LINE AMOUNT						
	1 00145300 6451		CARE & MA ELECTRIC L		21,477.02	21,477.02	92006				
20377	ENTERGY		INV	05/23/2023	19341494052323						
	ACCOUNT DETAIL				LINE AMOUNT						
	1 00550460 6451		PARKS - BA ELECTRIC L		3,925.20	3,925.20	92008				
20377	ENTERGY		INV	05/23/2023	19582154052323						
	ACCOUNT DETAIL				LINE AMOUNT						
	1 00145300 6451		CARE & MA ELECTRIC L		6,487.52	6,487.52	92014				
20377	ENTERGY		INV	05/23/2023	19583129052323						
	ACCOUNT DETAIL				LINE AMOUNT						
	1 00144170 6451		FIRE STAT ELECTRIC L		398.90	398.90	92017				
20377	ENTERGY		INV	05/23/2023	19584663052323						
	ACCOUNT DETAIL				LINE AMOUNT						
	1 00145300 6451		CARE & MA ELECTRIC L		832.30	832.30	92018				
20377	ENTERGY		INV	05/23/2023	19585355052323						
	ACCOUNT DETAIL				LINE AMOUNT						
	1 00550480 6451		PARKS - M ELECTRIC L		31.69	31.69	92019				
20377	ENTERGY		INV	05/23/2023	1958553052323						
	ACCOUNT DETAIL				LINE AMOUNT						
	1 00145300 6451		CARE & MA ELECTRIC L		116.20	116.20	92021				
20377	ENTERGY		INV	05/23/2023	19585900052323						
	ACCOUNT DETAIL				LINE AMOUNT						
	1 00144170 6451		FIRE STAT ELECTRIC L		3,993.87	3,993.87	92022				
20377	ENTERGY		INV	05/23/2023	19731207052323						
	ACCOUNT DETAIL				LINE AMOUNT						
	1 00550125 6451		PROGRAMMEELECTRIC L		330.01	330.01					

City of Jackson



ACCOUNTS PAYABLE CHECK RUN REPORT

Detail Invoice List

CHECK RUN: CD052323 05/23/2023
 DUE DATE: 05/23/2023

CASH ACCOUNT: 999		1100		POOLED CASH - AP DISBURSEMENTS						
VENDOR	REMIT	PO	TYPE	DUE DATE	INVOICE	AMOUNT	DOCUMENT	VOUCHER	CHECK	
20377	ENTERGY		INV	05/23/2023	19786045052323		92026			
	ACCOUNT DETAIL				LINE AMOUNT					
	1 00550180 6451		AQUATICS ELECTRIC L		32.80	32.80				
20377	ENTERGY		INV	05/23/2023	19816537052323		92029			
	ACCOUNT DETAIL				LINE AMOUNT					
	1 03152240 6451		FIELD O & ELECTRIC L		329.10	329.10				
20377	ENTERGY		INV	05/23/2023	19825918052323		92031			
	ACCOUNT DETAIL				LINE AMOUNT					
	1 00144220 6451		SUPPORT S ELECTRIC L		12.13	12.13				
20377	ENTERGY		INV	05/23/2023	19831767052323		92032			
	ACCOUNT DETAIL				LINE AMOUNT					
	1 00145300 6451		CARE & MA ELECTRIC L		2,620.27	2,620.27				
20377	ENTERGY		INV	05/23/2023	19832625052323		92036			
	ACCOUNT DETAIL				LINE AMOUNT					
	1 00550125 6451		PROGRAMMELECTRIC L		278.76	278.76				
20377	ENTERGY		INV	05/23/2023	19832963052323		92037			
	ACCOUNT DETAIL				LINE AMOUNT					
	1 00550180 6451		AQUATICS ELECTRIC L		34.05	34.05				
20377	ENTERGY		INV	05/23/2023	19833300052323		92039			
	ACCOUNT DETAIL				LINE AMOUNT					
	1 00144242 6451		PRECINCT ELECTRIC L		47.79	47.79				
20377	ENTERGY		INV	05/23/2023	19833508052323		92040			
	ACCOUNT DETAIL				LINE AMOUNT					
	1 00550460 6451		PARKS-BA ELECTRIC L		766.71	766.71				
20377	ENTERGY		INV	05/23/2023	19833714052323		92041			
	ACCOUNT DETAIL				LINE AMOUNT					
	1 00144220 6451		SUPPORT S ELECTRIC L		385.30	385.30				

City of Jackson



ACCOUNTS PAYABLE CHECK RUN REPORT

Detail Invoice List

CHECK RUN: CD052323 05/23/2023
 DUE DATE: 05/23/2023

CASH ACCOUNT	999	1100	POOLED CASH - AP DISBURSEMENTS			INVOICE	AMOUNT	DOCUMENT	VOUCHER	CHECK
VENDOR	REMIT	PO	TYPE	DUE DATE	LINE AMOUNT					
20377	ENTERGY		INV	05/23/2023	19833904052323					
	ACCGUNT DETAIL				LINE AMOUNT					
	1	00144220	SUPPORT S ELECTRIC L		34.23					
20377	ENTERGY		INV	05/23/2023	39450929052323					
	ACCGUNT DETAIL				LINE AMOUNT					
	1	03152240	FIELD O & ELECTRIC L		139.45					
20377	ENTERGY		INV	05/23/2023	40145237052323					
	ACCGUNT DETAIL				LINE AMOUNT					
	1	00144220	SUPPORT S ELECTRIC L		57.25					
20377	ENTERGY		INV	05/23/2023	48262943052323					
	ACCGUNT DETAIL				LINE AMOUNT					
	1	00144220	SUPPORT S ELECTRIC L		13,254.28					
20377	ENTERGY		INV	05/23/2023	55985543052323					
	ACCGUNT DETAIL				LINE AMOUNT					
	1	00145300	CARE & MA ELECTRIC L		32.64					
20377	ENTERGY		INV	05/23/2023	60188810052323					
	ACCGUNT DETAIL				LINE AMOUNT					
	1	00144241	PRECINCT ELECTRIC L		1,490.44					
20377	ENTERGY		INV	05/23/2023	60378254052323					
	ACCGUNT DETAIL				LINE AMOUNT					
	1	00144225	CRIME LAB ELECTRIC L		985.50					
20377	ENTERGY		INV	05/23/2023	70585534052323					
	ACCGUNT DETAIL				LINE AMOUNT					
	1	00140700	LEGAL ELECTRIC L		390.65					
20377	ENTERGY		INV	05/23/2023	85381358052323					
	ACCGUNT DETAIL				LINE AMOUNT					
	1	00144225	CRIME LAB ELECTRIC L		128.47					

Report generated: 05/18/2023 10:26:37
 User: Gloria Jones (gloriej)
 Program ID: apwarrrt

City of Jackson

ACCOUNTS PAYABLE CHECK RUN REPORT

Detail Invoice List

CHECK RUN: CD052323 05/23/2023
 DUE DATE: 05/23/2023



VENDOR	CASH ACCOUNT	999	1100	REMIT	PO	TYPE	DUE DATE	INVOICE	AMOUNT	DOCUMENT	VOUCHER	CHECK
20377	ENERGY			0000		INV	05/23/2023	85440345052323		92061		
	ACCOUNT DETAIL							LINE AMOUNT				
		1	00144244 6451			PRECINCT ELECTRIC L		27.42				
20377	ENERGY			0000		INV	05/23/2023	85440386052323		92062		
	ACCOUNT DETAIL							LINE AMOUNT				
		1	00144244 6451			PRECINCT ELECTRIC L		27.42				
20377	ENERGY			0000		INV	05/23/2023	85449734052323		92063		
	ACCOUNT DETAIL							LINE AMOUNT				
		1	00144244 6451			PRECINCT ELECTRIC L		27.42				
20377	ENERGY			0000		INV	05/23/2023	92513530052323		92066		
	ACCOUNT DETAIL							LINE AMOUNT				
		1	00145300 6451			CARE & MA ELECTRIC L		10,841.23				
								CHECK TOTAL	117,458.09			
400114	ENVIRONMENTAL ANALYTI			0000		INV	05/09/2023	23030311		89916		
	ACCOUNT DETAIL							LINE AMOUNT				
		1	00144470 6446			COMMUNITYCONTRACT		70.00				
400114	ENVIRONMENTAL ANALYTI			0000		INV	05/23/2023	23030310		89917		
	ACCOUNT DETAIL							LINE AMOUNT				
		1	00144470 6446			COMMUNITYCONTRACT		28.00				
400114	ENVIRONMENTAL ANALYTI			0000		INV	05/09/2023	23030309		89918		
	ACCOUNT DETAIL							LINE AMOUNT				
		1	00144470 6446			COMMUNITYCONTRACT		42.00				
400114	ENVIRONMENTAL ANALYTI			0000		INV	05/23/2023	23042517		90852		
	ACCOUNT DETAIL							LINE AMOUNT				
		1	00144470 6446			COMMUNITYCONTRACT		30.00				
400114	ENVIRONMENTAL ANALYTI			0000		INV	05/09/2023	23042518		90853		
	ACCOUNT DETAIL							LINE AMOUNT				
		1	00144470 6446			COMMUNITYCONTRACT		60.00				

Report generated: 05/18/2023 10:26:37
 User: Gloria Jones (gloriaj)
 Program ID: apwarrml

City of Jackson



ACCOUNTS PAYABLE CHECK RUN REPORT

Detail Invoice List

CHECK RUN: CD052323 05/23/2023
 DUE DATE: 05/23/2023

CASH ACCOUNT: 999		1100		POOLED CASH - AP DISBURSEMENTS									
VENDOR		REMIT	PO	TYPE	DUE DATE	INVOICE	AMOUNT	DOCUMENT	VOUCHER	CHECK			
400114	ENVIRONMENTAL ANALYTI	0000		INV	05/23/2023	23042519							
	ACCOUNT DETAIL					LINE AMOUNT							
	1 00144470 6446					30.00		90854					
400114	ENVIRONMENTAL ANALYTI	0000		INV	05/23/2023	23042515							
	ACCOUNT DETAIL					LINE AMOUNT							
	1 00144470 6446					36.00		90855					
400114	ENVIRONMENTAL ANALYTI	0000		INV	05/23/2023	23042516							
	ACCOUNT DETAIL					LINE AMOUNT							
	1 00144470 6446					42.00		90856					
400114	ENVIRONMENTAL ANALYTI	0000		INV	05/23/2023	23042513							
	ACCOUNT DETAIL					LINE AMOUNT							
	1 00144470 6446					30.00		90857					
400114	ENVIRONMENTAL ANALYTI	0000		INV	05/23/2023	23042514							
	ACCOUNT DETAIL					LINE AMOUNT							
	1 00144470 6446					54.00		90858					
400114	ENVIRONMENTAL ANALYTI	0000		INV	05/23/2023	23050312							
	ACCOUNT DETAIL					LINE AMOUNT							
	1 00144470 6446					54.00		91701					
400114	ENVIRONMENTAL ANALYTI	0000		INV	05/23/2023	23050313							
	ACCOUNT DETAIL					LINE AMOUNT							
	1 00144470 6446					42.00		91703					
400114	ENVIRONMENTAL ANALYTI	0000		INV	05/23/2023	23050315							
	ACCOUNT DETAIL					LINE AMOUNT							
	1 00144470 6446					36.00		91704					
400114	ENVIRONMENTAL ANALYTI	0000		INV	05/23/2023	23050812							
	ACCOUNT DETAIL					LINE AMOUNT							
	1 00144470 6446					24.00		91705					

City of Jackson

ACCOUNTS PAYABLE CHECK RUN REPORT

Detail Invoice List

CHECK RUN: CD052323 05/23/2023
 DUE DATE: 05/23/2023



CASH ACCOUNT: 999		1100		POOLED CASH - AP DISBURSEMENTS				INVOICE	AMOUNT	DOCUMENT	VOUCHER	CHECK
VENDOR	REMIT	PO	TYPE	DUE DATE	INVOICE	AMOUNT	DOCUMENT	VOUCHER	CHECK			
400114	ENVIRONMENTAL ANALYTI	0000	INV	05/23/2023	23050813		91707					
	ACCOUNT DETAIL				LINE AMOUNT							
	1 00144470 6446		COMMUNITYCONTRACT		64.00	64.00						
					CHECK TOTAL	642.00						
60520	ENVIRONMENTAL MANAGEM	0000	INV	05/23/2023	102634		91682					
	ACCOUNT DETAIL				LINE AMOUNT							
	1 08592110 6419		FIRE STAT OTHER PROF		15,700.00	15,700.00						
					CHECK TOTAL	15,700.00						
46286	ENVIRONMENTAL SYSTEMS	0000	INV	05/23/2023	94485246		91706					
	ACCOUNT DETAIL				LINE AMOUNT							
	1 00140410 6231		PLANNING COMPUTER		960.00	960.00						
					CHECK TOTAL	960.00						
401944	FANNIE MOMAN	0000	INV	05/23/2023	001112751		91217					
	ACCOUNT DETAIL				LINE AMOUNT							
	1 00550126 6419		ATHLETICS OTHER PRO		33.00	33.00						
					CHECK TOTAL	33.00						
401944	FANNIE MOMAN	0000	INV	05/23/2023	001112742		91294					
	ACCOUNT DETAIL				LINE AMOUNT							
	1 00550126 6419		ATHLETICS OTHER PRO		33.00	33.00						
					CHECK TOTAL	33.00						
401944	FANNIE MOMAN	0000	INV	05/23/2023	001112760		91505					
	ACCOUNT DETAIL				LINE AMOUNT							
	1 00550126 6419		ATHLETICS OTHER PRO		33.00	33.00						
					CHECK TOTAL	99.00						
6286	FEDEX	0000	INV	05/23/2023	8-090-12985		90901					
	ACCOUNT DETAIL				LINE AMOUNT							
	1 00144120 6422		EMERGENCYFREIGHT E		12.55	12.55						

Report generated: 05/18/2023 10:28:37
 User: Gloria Jones (gloriaj)
 Program ID: apwarrnt

City of Jackson



ACCOUNTS PAYABLE CHECK RUN REPORT

Detail Invoice List

CHECK RUN: CD052323 05/23/2023
 DUE DATE: 05/23/2023

CASH ACCOUNT: 999		1100		POOLED CASH - AP DISBURSEMENTS							
VENDOR	REMIT	PO	TYPE	DUE DATE	INVOICE	AMOUNT	DOCUMENT	VOUCHER	CHECK		
6266	FEDEX	0000	INV	05/23/2023	8-126-53647		91534				
ACCOUNT DETAIL					LINE AMOUNT						
1	18756520	6422	TRANSIT S FREIGHT E		29.55						
CHECK TOTAL						29.55					
48050	FLEETCOR TECHNOLOGIES	0000	INV	05/23/2023	NP64352735		91838				
ACCOUNT DETAIL					LINE AMOUNT						
1	001	2390	GENERAL F DUE TO FUE		45,681.98						
48050	FLEETCOR TECHNOLOGIES	0000	INV	05/23/2023	NP64376651		91839				
ACCOUNT DETAIL					LINE AMOUNT						
1	001	2390	GENERAL F DUE TO FUE		44,342.80						
CHECK TOTAL						90,024.78					
61274	FLEETPRIDE	0000	INV	05/23/2023	107670290		91672				
ACCOUNT DETAIL					LINE AMOUNT						
1	00144120	6316	EMERGENCMOTOR VEH		825.00						
CHECK TOTAL						825.00					
69407	FLOWOOD FASTENER & SU	0000	INV	05/23/2023	165591		91677				
ACCOUNT DETAIL					LINE AMOUNT						
1	00144120	6316	EMERGENCMOTOR VEH		8.49						
CHECK TOTAL						8.49					
401913	FRENCH AWNING & SCREE	0000	INV	05/23/2023	16607-1		91387				
ACCOUNT DETAIL					LINE AMOUNT						
1	40643350	6419	DFA-TMH 2MOTHER PROF		14,231.25						
CHECK TOTAL						14,231.25					
71958	FUSE.CLOUD	0000	INV	05/23/2023	88606		90874				
ACCOUNT DETAIL					LINE AMOUNT						
1	18756520	6454	TRANSIT S TELEPHONE		3,471.09						
CHECK TOTAL						3,471.09					

Report generated: 05/18/2023 10:26:37
 User: Gloria Jones (gloriaj)
 Program ID: spwarnr

City of Jackson



ACCOUNTS PAYABLE CHECK RUN REPORT

Detail Invoice List

CHECK RUN: CD052323 05/23/2023
 DUE DATE: 05/23/2023

CASH ACCOUNT	999	1100	REMIT	PO	TYPE	DUE DATE	INVOICE	AMOUNT	DOCUMENT	VOUCHER	CHECK
POOLED CASH - AP DISBURSEMENTS											
63860	G & G ENTERPRISES	ACCOUNT DETAIL	0000	23001183	EFT	05/23/2023	2023-2804		91264		
	1 00144810	6299		TRAFFIC A	OTHER OPE		LINE AMOUNT	96.00			
	2 00144820	6299		TRAFFIC S	OTHER OPE		LINE AMOUNT	935.66			
							CHECK TOTAL	3,471.09			
63860	G & G ENTERPRISES	ACCOUNT DETAIL	0000	77230546	EFT	05/23/2023	2023-0405		91277		
	1 00145700	6213		CUSTODIAL	CLEANING		LINE AMOUNT	136.00			
							CHECK TOTAL	1,167.66			
400408	GEANETTE GROSS PERKI	ACCOUNT DETAIL	0000		INV	05/23/2023	00112759		91504		
	1 00550126	6419		ATHLETICS	OTHER PRO		LINE AMOUNT	33.00			
							CHECK TOTAL	33.00			
401551	GENESIS AND LIGHT CEN	ACCOUNT DETAIL	0000		INV	05/23/2023	0001		91779		
	1 08571534	6742		CDBG-GEN&CENTRB	OTH		LINE AMOUNT	2,578.19			
							CHECK TOTAL	2,578.19			
401551	GENESIS AND LIGHT CEN	ACCOUNT DETAIL	0000		INV	05/23/2023	0002		91781		
	1 08571534	6742		CDBG-GEN&CENTRB	OTH		LINE AMOUNT	4,278.06			
							CHECK TOTAL	4,278.06			
401551	GENESIS AND LIGHT CEN	ACCOUNT DETAIL	0000		INV	05/23/2023	1000		91785		
	1 08571534	6742		CDBG-GEN&CENTRB	OTH		LINE AMOUNT	6,134.44			
							CHECK TOTAL	12,990.69			
63422	GLOBAL SECTOR SERVICE	ACCOUNT DETAIL	0000	77230532	INV	05/23/2023	65038		91280		
	1 00141910	6317		MUNICIPAL	OTHER REP		LINE AMOUNT	590.70			
							CHECK TOTAL	590.70			

Report generated: 05/18/2023 10:26:37
 User: Gloria Jones (gloriaj)
 Program ID: apwarrnt

City of Jackson



ACCOUNTS PAYABLE CHECK RUN REPORT

Detail Invoice List

CHECK RUN: CD052323 05/23/2023
 DUE DATE: 05/23/2023

CASH ACCOUNT: 999		1100		POOLED CASH - AP DISBURSEMENTS						
VENDOR	REMIT	PO	TYPE	DUE DATE	INVOICE	AMOUNT	DOCUMENT	VOUCHER	CHECK	
68422	GLOBAL SECTOR SERVICE	0000	77230531	INV	05/23/2023	65073				
	ACCOUNT DETAIL					LINE AMOUNT				
	1 00141910 6317					280.35				
						CHECK TOTAL				
						280.35				
						871.05				
72753	GRACE HOUSE INC	0000		EFT	05/23/2023	183				
	ACCOUNT DETAIL					LINE AMOUNT				
	1 12256615 6742					104,252.51				
						CHECK TOTAL				
						104,252.51				
						104,252.51				
400052	GRAINGER	0000	23001196	INV	05/23/2023	9683872452				
	ACCOUNT DETAIL					LINE AMOUNT				
	1 39049800 6317					272.21				
						CHECK TOTAL				
						272.21				
						272.21				
68462	H & E EQUIPMENT SERVI	0000		INV	05/23/2023	96876413				
	ACCOUNT DETAIL					LINE AMOUNT				
	1 37652010 6514					2,615.02				
						CHECK TOTAL				
						2,615.02				
						2,615.02				
68462	H & E EQUIPMENT SERVI	0000		INV	05/23/2023	96994398				
	ACCOUNT DETAIL					LINE AMOUNT				
	1 37652010 6514					2,615.02				
						CHECK TOTAL				
						2,615.02				
						2,615.02				
68462	H & E EQUIPMENT SERVI	0000		INV	05/23/2023	97047276				
	ACCOUNT DETAIL					LINE AMOUNT				
	1 37652010 6514					2,615.02				
						CHECK TOTAL				
						2,615.02				
						2,615.02				
68462	H & E EQUIPMENT SERVI	0000		INV	05/23/2023	97104649				
	ACCOUNT DETAIL					LINE AMOUNT				
	1 37652010 6514					2,615.02				
						CHECK TOTAL				
						2,615.02				
						2,615.02				

Report generated: 05/18/2023 10:26:37
 User: Gloria Jones (glorjaj)
 Program ID: apwarml



City of Jackson

ACCOUNTS PAYABLE CHECK RUN REPORT

Detail Invoice List

CHECK RUN: CD052323 05/23/2023
 DUE DATE: 05/23/2023

CASH ACCOUNT	999	1100	REMT	PO	TYPE	DUE DATE	INVOICE	AMOUNT	DOCUMENT	VOUCHER	CHECK
68462	H & E EQUIPMENT SERVI	ACCOUNT DETAIL	0000		INV	05/23/2023	97163209		91752		
	1	37652010 6514			WATER RENTAL OF		2,615.02	2,615.02			
							LINE AMOUNT				
							CHECK TOTAL	2,765.02			
								18,455.14			
68462	H & E EQUIPMENT SERVI	ACCOUNT DETAIL	0000		INV	05/23/2023	96814803		91757		
	1	37652010 6514			WATER RENTAL OF		2,765.02	2,765.02			
							LINE AMOUNT				
							CHECK TOTAL	4,126.00			
								4,126.00			
66653	HARDISON ENTERPRISES	ACCOUNT DETAIL	0000		INV	05/23/2023	50423		91880		
	1	00144170 6461			FIRE STAT BUILDINGS		4,126.00	4,126.00			
							LINE AMOUNT				
							CHECK TOTAL	290.16			
								290.16			
7715	HARLEY-DAVIDSON OF CE	ACCOUNT DETAIL	0000		INV	05/23/2023	40998		91384		
	1	00144240 6316			OPERATION MOTOR VEH		290.16	290.16			
							LINE AMOUNT				
							CHECK TOTAL	290.16			
								290.16			
20570	HEMPHILL CONST. CO.	ACCOUNT DETAIL	0000		EFT	05/23/2023	043023-6		90903		
	1	42045190 6824			MDOT-CMPDOTBC		281,028.05	281,028.05			
	2	17345190 6824			1% ENG CAPIMPROVEMEN		93,675.35	93,675.35			
							LINE AMOUNT				
							CHECK TOTAL	374,701.40			
								374,701.40			
68345	HOME DEPOT COMMERCIAL	ACCOUNT DETAIL	0000		INV	05/23/2023	973450		91295		
	1	00550126 6311			ATHLETICS BUILDING		86.00	86.00			
							LINE AMOUNT				
							CHECK TOTAL	39.71			
								39.71			
68345	HOME DEPOT COMMERCIAL	ACCOUNT DETAIL	0000		INV	05/23/2023	972419		91389		
	1	00550180 6311			AQUATICS BUILDING		39.71	39.71			
							LINE AMOUNT				
							CHECK TOTAL	39.71			
								39.71			

Report generated: 05/18/2023 10:26:37
 User: Gloria Jones (gloriaj)
 Program ID: apwerrrrl

City of Jackson



ACCOUNTS PAYABLE CHECK RUN REPORT

Detail Invoice List

CHECK RUN: CD052323 05/23/2023
 DUE DATE: 05/23/2023

CASH ACCOUNT: 999		1100		POOLED CASH - AP DISBURSEMENTS						
VENDOR	REMIT	PO	TYPE	DUE DATE	INVOICE	AMOUNT	DOCUMENT	VOUCHER	CHECK	
68345	HOME DEPOT COMMERCIAL	99230227	INV	05/23/2023	972249		91727			
	ACCOUNT DETAIL				LINE AMOUNT					
	1 00145610 6299		VEHICLE M OTHER OPE		505.80					
					CHECK TOTAL	505.80				
						631.51				
8392	HOTEL & RESTAURANT SU	22001947	INV	05/23/2023	3122850		91652			
	ACCOUNT DETAIL				LINE AMOUNT					
	1 00144226 6419		STANDARDSOTHER PRO		3,293.00					
					CHECK TOTAL	3,293.00				
						3,293.00				
8555	HYDRAULIC SERVICE & S	99230146	EFT	05/23/2023	132702		91774			
	ACCOUNT DETAIL				LINE AMOUNT					
	1 03152210 6316		ADMINISTR MOTOR VEH		574.00					
						574.00				
8555	HYDRAULIC SERVICE & S	99230146	EFT	05/23/2023	132629		91775			
	ACCOUNT DETAIL				LINE AMOUNT					
	1 00950610 6316		LANDFILL MOTOR VEH		853.50					
						853.50				
8555	HYDRAULIC SERVICE & S	99230146	EFT	05/17/2023	132725		91776			
	ACCOUNT DETAIL				LINE AMOUNT					
	1 00950610 6316		LANDFILL MOTOR VEH		1,611.67					
						1,611.67				
8555	HYDRAULIC SERVICE & S	99230146	EFT	05/23/2023	132774		91777			
	ACCOUNT DETAIL				LINE AMOUNT					
	1 00145124 6316		SBD - PAV MOTOR VEH		31.88					
						31.88				
					CHECK TOTAL	3,071.05				
67504	IATSE LOCAL 589	23001210	INV	05/23/2023	4182023		91708			
	ACCOUNT DETAIL				LINE AMOUNT					
	1 00550125 6419		PROGRAMMOTHER PRO		1,016.40					
						1,016.40				
67504	IATSE LOCAL 589		INV	05/23/2023	03202023		91811			
	ACCOUNT DETAIL				LINE AMOUNT					
	1 00550125 6419		PROGRAMMOTHER PRO		605.00					
						605.00				

City of Jackson



ACCOUNTS PAYABLE CHECK RUN REPORT

Detail Invoice List

CHECK RUN: CD052323 05/23/2023
 DUE DATE: 05/23/2023

VENDOR	CASH ACCOUNT:	999	1100	REMIT	PO	TYPE	DUE DATE	INVOICE	AMOUNT	DOCUMENT	VOUCHER	CHECK
72116	ICC			0000	23000892	INV	05/23/2023	1001676463		90883		
								LINE AMOUNT				
								CHECK TOTAL	1,621.40			
72116	ICC			0000	23000892	INV	05/23/2023	1001649130		90884		
								LINE AMOUNT				
								CHECK TOTAL	345.00			
401934	INDUSTRIAL SERVICES C			0000	2022 GO PL OTHER PROF	INV	05/23/2023	5754		91588		
								LINE AMOUNT				
								CHECK TOTAL	1,940.00			
67938	INTEGRATED PEST SERVI			0000	PROGRAMMOTHER PRO	INV	05/23/2023	80128		91318		
								LINE AMOUNT				
								CHECK TOTAL	40.00			
67938	INTEGRATED PEST SERVI			0000	PROGRAMMOTHER PRO	INV	05/23/2023	80110		91320		
								LINE AMOUNT				
								CHECK TOTAL	40.00			
67938	INTEGRATED PEST SERVI			0000	PROGRAMMOTHER PRO	INV	05/23/2023	80111		91321		
								LINE AMOUNT				
								CHECK TOTAL	40.00			
67938	INTEGRATED PEST SERVI			0000	PROGRAMMOTHER PRO	INV	05/23/2023	80112		91322		
								LINE AMOUNT				
								CHECK TOTAL	40.00			

City of Jackson



ACCOUNTS PAYABLE CHECK RUN REPORT

Detail Invoice List

CHECK RUN: CD052323 05/23/2023
 DUE DATE: 05/23/2023

CASH ACCOUNT: 999		1100		POOLED CASH - AP DISBURSEMENTS						
VENDOR	REMIT	PO	TYPE	DUE DATE	INVOICE	AMOUNT	DOCUMENT	VOUCHER	CHECK	
401899	IPMA-HR SOUTHERN REGI	0000	INV	05/23/2023	INV-75882-C9R7VO		91812			
	ACCOUNT DETAIL				LINE AMOUNT					
	1 00141300 6443		PERSONNELDUES, MEM.		1,025.00					
			CHECK TOTAL		1,025.00					
8958	JACKSON ADVOCATE THE	0000	EFT	05/23/2023	5000		91525			
	ACCOUNT DETAIL				LINE AMOUNT					
	1 00142630 6444		BUSINESS LEGAL ADS		81.40					
			CHECK TOTAL		81.40					
8980	JACKSON BLUE PRINT &	0000	INV	05/23/2023	842090		90893			
	ACCOUNT DETAIL				LINE AMOUNT					
	1 00140310 6218		LAND USE OFFICE SU		274.20					
	2 00140320 6218		ZONING DI OFFICE SU		76.64					
	3 00144420 6218		BUILDING OFFICE SU		274.20					
	4 00144470 6218		COMMUNITYOFFICE SU		247.60					
			CHECK TOTAL		872.64					
72879	JACKSON CONVENTION CO	0000	EFT	05/23/2023	6582		91810			
	ACCOUNT DETAIL				LINE AMOUNT					
	1 00550110 6512		ADMIN PAR BUILDING		1,000.00					
			CHECK TOTAL		1,000.00					
73375	JACKSON MAC HAIK F LT	0000	INV	05/23/2023	3097299		90745			
	ACCOUNT DETAIL				LINE AMOUNT					
	1 00144240 6316		OPERATION MOTOR VEH		47.72					
			CHECK TOTAL		47.72					
73375	JACKSON MAC HAIK F LT	0000	INV	05/23/2023	3098098		90750			
	ACCOUNT DETAIL				LINE AMOUNT					
	1 00144240 6316		OPERATION MOTOR VEH		123.16					
			CHECK TOTAL		123.16					
73375	JACKSON MAC HAIK F LT	0000	INV	05/23/2023	3108250		91780			
	ACCOUNT DETAIL				LINE AMOUNT					
	1 00144240 6316		OPERATION MOTOR VEH		3,260.00					

Report generated: 05/18/2023 10:28:37
 User: Gloria Jones (gloriaj)
 Program ID: apwarrnt

City of Jackson



ACCOUNTS PAYABLE CHECK RUN REPORT

Detail Invoice List

CHECK RUN: CD052323 05/23/2023
 DUE DATE: 05/23/2023

CASH ACCOUNT	999	1100	REMIT	PO	TYPE	DUE DATE	INVOICE	AMOUNT	DOCUMENT	VOUCHER	CHECK
73375	JACKSON MAC HAIK F LT	0000	99230232	INV	05/23/2023	3108249	3,250.00	91783			
	ACCOUNT DETAIL										
	1 00144240 6316			OPERATION MOTOR VEH			16,148.00				
				CHECK TOTAL			19,578.88				
9387	JACKSON SUPPLY CO	0000	77230557	INV	05/23/2023	S5947242.001		91691			
	ACCOUNT DETAIL										
	1 00144170 6461			FIRE STAT BUILDINGS			67.81				
				CHECK TOTAL			67.81				
66452	JAMBOREE CHILD DEVEL	0000		EFT	05/23/2023	210405		91788			
	ACCOUNT DETAIL										
	1 08584610 6742			JAMBOREE CTOA			1,900.00				
				CHECK TOTAL			1,900.00				
401245	JAMES E SMITH	0000		INV	05/23/2023	001112749		91213			
	ACCOUNT DETAIL										
	1 00550126 6419			ATHLETICS OTHER PRO			75.00				
				CHECK TOTAL			75.00				
401245	JAMES E SMITH	0000		INV	05/23/2023	001112758		91503			
	ACCOUNT DETAIL										
	1 00550126 6419			ATHLETICS OTHER PRO			75.00				
				CHECK TOTAL			75.00				
401195	JAMYE TERRELL HORTON	0000		INV	05/23/2023	001112750		91214			
	ACCOUNT DETAIL										
	1 00550126 6419			ATHLETICS OTHER PRO			33.00				
				CHECK TOTAL			33.00				
71125	JENKINS AUTOMOTIVES	0000	99230211	EFT	05/23/2023	726		91784			
	ACCOUNT DETAIL										
	1 00144240 6316			OPERATION MOTOR VEH			1,950.00				

Report generated: 05/18/2023 10:26:37
 User: Gloria Jones (gloriaj)
 Program ID: apwarrrl

City of Jackson



ACCOUNTS PAYABLE CHECK RUN REPORT

Detail Invoice List

CHECK RUN: CD052323 05/23/2023
 DUE DATE: 05/23/2023

VENDOR	CASH ACCOUNT: 999	1100	REMIT	PO	TYPE	DUE DATE	INVOICE	AMOUNT	DOCUMENT	VOUCHER	CHECK
71125	JENKINS AUTOMOTIVES ACCOUNT DETAIL		0000	99230211	EFT	05/23/2023	727 LINE AMOUNT	1,950.00	91786		
	1 00144240 6316						1,500.00				
71125	JENKINS AUTOMOTIVES ACCOUNT DETAIL		0000	99230211	EFT	05/23/2023	718 LINE AMOUNT	1,500.00	91787		
	1 00144240 6316						150.00				
71125	JENKINS AUTOMOTIVES ACCOUNT DETAIL		0000	99230211	EFT	05/23/2023	719 LINE AMOUNT	150.00	91789		
	1 00144240 6316						150.00				
71125	JENKINS AUTOMOTIVES ACCOUNT DETAIL		0000	99230211	EFT	05/23/2023	720 LINE AMOUNT	855.00	91790		
	1 00144240 6316						855.00				
71125	JENKINS AUTOMOTIVES ACCOUNT DETAIL		0000	99230211	EFT	05/23/2023	721 LINE AMOUNT	389.50	91791		
	1 00144240 6316						389.50				
71125	JENKINS AUTOMOTIVES ACCOUNT DETAIL		0000	99230211	EFT	05/23/2023	723 LINE AMOUNT	872.00	91792		
	1 00144240 6316						872.00				
71125	JENKINS AUTOMOTIVES ACCOUNT DETAIL		0000	99230211	EFT	05/23/2023	724 LINE AMOUNT	190.00	91793		
	1 00144240 6316						190.00				
71125	JENKINS AUTOMOTIVES ACCOUNT DETAIL		0000	99230211	EFT	05/23/2023	725 LINE AMOUNT	580.00	91794		
	1 00144240 6316						580.00				
71125	JENKINS AUTOMOTIVES ACCOUNT DETAIL		0000	99230211	EFT	05/23/2023	722 LINE AMOUNT	123.50	91795		
	1 00144240 6316						123.50				
							CHECK TOTAL	6,760.00			

Report generated: 05/19/2023 10:26:37
 User: Gloria James (gloriej)
 Program ID: spwsmrnl



City of Jackson

ACCOUNTS PAYABLE CHECK RUN REPORT

Detail Invoice List

CHECK RUN: CD052323 05/23/2023
 DUE DATE: 05/23/2023

VENDOR	CASH ACCOUNT	999	1100	REMIT	PO	TYPE	DUE DATE	INVOICE	AMOUNT	DOCUMENT	VOUCHER	CHECK
9660	JOHNSON CONTROLS INC	ACCOUNT DETAIL	1 00145300 6468	0000		EFT	05/23/2023	00073950486	5,207.75	91358		
									5,207.75			
									CHECK TOTAL			
									5,207.75			
53714	JOHNSTONE SUPPLY OF J	ACCOUNT DETAIL	1 00144225 6419	0000		CRIME LAB OTHER PRO	05/23/2023	71-S5601171.001	90.18	91273		
									90.18			
									CHECK TOTAL			
									90.18			
53714	JOHNSTONE SUPPLY OF J	ACCOUNT DETAIL	1 00145300 6461	0000		CARE & MA BUILDINGS	05/23/2023	71-S5613471.001	275.40	91833		
									275.40			
									CHECK TOTAL			
									275.40			
53714	JOHNSTONE SUPPLY OF J	ACCOUNT DETAIL	1 00144170 6461	0000		FIRE STAT BUILDINGS	06/06/2023	71-S5614487.001	71.62	91883		
									71.62			
									CHECK TOTAL			
									71.62			
70866	KENWORTH of MISSISSIP	ACCOUNT DETAIL	1 00550410 6464	0000		PARKS - M MACHINE/E	05/23/2023	527934	2,364.22	91722		
									2,364.22			
									CHECK TOTAL			
									2,364.22			
70866	KENWORTH of MISSISSIP	ACCOUNT DETAIL	1 00145124 6316	0000		SBD - PAV MOTOR VEH	05/23/2023	527270	1,452.00	91723		
									1,452.00			
									CHECK TOTAL			
									3,816.22			
401846	KOLOGIK LLC	ACCOUNT DETAIL	1 00390825 6847	0000		HIDTA DATA PROC	05/23/2023	INV-10566	49,666.67	91813		
									49,666.67			
									CHECK TOTAL			
									49,666.67			

Report generated: 05/18/2023 10:26:37
 User: Gloria Jones (gloriaj)
 Program ID: epwarrnt

City of Jackson



ACCOUNTS PAYABLE CHECK RUN REPORT

Detail Invoice List

CHECK RUN: CD062323 05/23/2023
 DUE DATE: 05/23/2023

CASH ACCOUNT: 999		1100		POOLED CASH - AP DISBURSEMENTS						
VENDOR		REMIT	PO	TYPE	DUE DATE	INVOICE	AMOUNT	DOCUMENT	VOUCHER	CHECK
401511	KOMLETE CONTRACTING	0000	23001143	INV	05/23/2023	3749		91616		
	ACCOUNT DETAIL					LINE AMOUNT				
	1 39049800 6311		ZOO PARK BUILDING M			4,950.00				
							4,950.00			
401511	KOMLETE CONTRACTING	0000	23001125	INV	05/23/2023	3751		91619		
	ACCOUNT DETAIL		ZOO PARK BUILDINGS			LINE AMOUNT				
	1 39049800 6461					4,990.00				
						CHECK TOTAL	9,940.00			
71370	LUIS ESPINOZA	0000		INV	05/23/2023	122385		91522		
	ACCOUNT DETAIL		BUSINESS LEGAL ADS			LINE AMOUNT				
	1 00142630 6444					150.00				
						CHECK TOTAL	150.00			
69165	LD PRODUCTS DBA 4M/KJ	0000	23000294	EFT	05/23/2023	SIP-013704186		91248		
	ACCOUNT DETAIL		PERSONNEL OFFICE SU			LINE AMOUNT				
	1 00141300 6218					383.85				
						CHECK TOTAL	383.85			
65329	LEWIS BODY SHOP & WRE	0000		EFT	05/23/2023	30927		91526		
	ACCOUNT DETAIL		SUPPORT S AUTO + TR			LINE AMOUNT				
	1 00144220 6465					75.00				
						CHECK TOTAL	75.00			
65329	LEWIS BODY SHOP & WRE	0000		EFT	05/23/2023	30949		91530		
	ACCOUNT DETAIL		SUPPORT S AUTO + TR			LINE AMOUNT				
	1 00144220 6465					75.00				
						CHECK TOTAL	75.00			
65329	LEWIS BODY SHOP & WRE	0000		EFT	05/23/2023	30950		91531		
	ACCOUNT DETAIL		SUPPORT S AUTO + TR			LINE AMOUNT				
	1 00144220 6465					75.00				
						CHECK TOTAL	75.00			
65329	LEWIS BODY SHOP & WRE	0000		EFT	05/23/2023	31051		91532		
	ACCOUNT DETAIL		SUPPORT S AUTO + TR			LINE AMOUNT				
	1 00144220 6465					75.00				
						CHECK TOTAL	75.00			

Report generated: 05/19/2023 10:28:37
 User: Gloria Jones (glorjnj)
 Program ID: apwarnt

City of Jackson



ACCOUNTS PAYABLE CHECK RUN REPORT

Detail Invoice List

CHECK RUN: CD052323 05/23/2023
 DUE DATE: 05/23/2023

CASH ACCOUNT: 999		1100		POOLED CASH - AP DISBURSEMENTS										
VENOR		REMIT	PO	TYPE	DUE DATE	INVOICE	AMOUNT	DOCUMENT	VOUCHER	CHECK				
65329	LEWIS BODY SHOP & WIRE	0000		EFT	05/23/2023	31052		91533						
	ACCOUNT DETAIL					LINE AMOUNT								
	1 00144220 6465			SUPPORT S AUTO + TR		75.00								
65329	LEWIS BODY SHOP & WIRE	0000		EFT	05/23/2023	31053		91535						
	ACCOUNT DETAIL					LINE AMOUNT								
	1 00144220 6465			SUPPORT S AUTO + TR		75.00								
65329	LEWIS BODY SHOP & WIRE	0000		EFT	05/23/2023	31054		91536						
	ACCOUNT DETAIL					LINE AMOUNT								
	1 00144220 6465			SUPPORT S AUTO + TR		75.00								
65329	LEWIS BODY SHOP & WIRE	0000		EFT	05/23/2023	31055		91537						
	ACCOUNT DETAIL					LINE AMOUNT								
	1 00144220 6465			SUPPORT S AUTO + TR		75.00								
65329	LEWIS BODY SHOP & WIRE	0000		EFT	05/23/2023	31057		91538						
	ACCOUNT DETAIL					LINE AMOUNT								
	1 00144220 6465			SUPPORT S AUTO + TR		75.00								
65329	LEWIS BODY SHOP & WIRE	0000		EFT	05/23/2023	31058		91539						
	ACCOUNT DETAIL					LINE AMOUNT								
	1 00144220 6465			SUPPORT S AUTO + TR		75.00								
65329	LEWIS BODY SHOP & WIRE	0000		EFT	05/23/2023	31060		91540						
	ACCOUNT DETAIL					LINE AMOUNT								
	1 00144220 6465			SUPPORT S AUTO + TR		75.00								
65329	LEWIS BODY SHOP & WIRE	0000		EFT	05/23/2023	31061		91541						
	ACCOUNT DETAIL					LINE AMOUNT								
	1 00144220 6465			SUPPORT S AUTO + TR		75.00								
65329	LEWIS BODY SHOP & WIRE	0000		EFT	05/23/2023	30866		91542						
	ACCOUNT DETAIL					LINE AMOUNT								
	1 00144220 6465			SUPPORT S AUTO + TR		75.00								

Report generated: 05/18/2023 10:26:37
 User: Gloria Jones (gloriaj)
 Program ID: apwerrnt

City of Jackson



ACCOUNTS PAYABLE CHECK RUN REPORT

Detail Invoice List

CHECK RUN: CD052323 05/23/2023
 DUE DATE: 05/23/2023

CASH ACCOUNT: 999		1100		POOLED CASH - AP DISBURSEMENTS									
VENDOR	REMIT	PO	TYPE	DUE DATE	INVOICE	AMOUNT	DOCUMENT	VOUCHER	CHECK	LINE AMOUNT	LINE AMOUNT	LINE AMOUNT	LINE AMOUNT
65329	LEWIS BODY SHOP & WRE	0000	EFT	05/23/2023	31055	45.00	91543			45.00	75.00	91872	
	ACCOUNT DETAIL												
	1 00144220 6465												
65329	LEWIS BODY SHOP & WRE	0000	EFT	05/23/2023	31001	45.00	91544			45.00	75.00	91871	
	ACCOUNT DETAIL												
	1 00144220 6465												
401874	LIFE ENHANCEMENT & AC	0000	INV	05/23/2023	1050	2,000.00	91571			2,000.00	8,225.00	91630	
	ACCOUNT DETAIL												
	1 00550110 6419												
73212	LITECLOUD TRANSPORT S	0000	EFT	09/02/2022	INV-92101799	8,225.00	91630			8,225.00	16,450.00	91641	
	ACCOUNT DETAIL												
	1 00490400 6419												
73212	LITECLOUD TRANSPORT S	0000	EFT	05/23/2023	INV-92101890	8,225.00	91641			8,225.00	16,450.00	91641	
	ACCOUNT DETAIL												
	1 00490400 6419												
60933	LOPER D JIMMY	0000	INV	05/23/2023	21178	75.00	91870			75.00	75.00	91870	
	ACCOUNT DETAIL												
	1 00144220 6465												
60933	LOPER D JIMMY	0000	INV	05/23/2023	21164	75.00	91871			75.00	75.00	91871	
	ACCOUNT DETAIL												
	1 00144220 6465												
60933	LOPER D JIMMY	0000	INV	05/23/2023	21179	75.00	91872			75.00	75.00	91872	
	ACCOUNT DETAIL												
	1 00144220 6465												



City of Jackson

ACCOUNTS PAYABLE CHECK RUN REPORT

Detail Invoice List

CHECK RUN: CD052323 05/23/2023
 DUE DATE: 05/23/2023

VENDOR	CASH ACCOUNT	999	1100	REMIT	PO	TYPE	DUE DATE	INVOICE	AMOUNT	DOCUMENT	VOUCHER	CHECK
60933	LOPER D JIMMY			0000		INV	05/23/2023	21171		91873		
	ACCOUNT DETAIL							LINE AMOUNT				
		1	00144220 6465					75.00				
60933	LOPER D JIMMY			0000		INV	05/23/2023	21182		91874		
	ACCOUNT DETAIL							LINE AMOUNT				
		1	00144220 6465					75.00				
60933	LOPER D JIMMY			0000		INV	05/23/2023	21183		91875		
	ACCOUNT DETAIL							LINE AMOUNT				
		1	00144220 6465					75.00				
								CHECK TOTAL	450.00			
63804	M & R PROTECTIVE SYST			0000		INV	05/23/2023	13405		91271		
	ACCOUNT DETAIL							LINE AMOUNT				
		1	00145300 6461					288.00				
63804	M & R PROTECTIVE SYST			0000		INV	05/23/2023	13249		91276		
	ACCOUNT DETAIL							LINE AMOUNT				
		1	00145300 6461					178.50				
								CHECK TOTAL	466.50			
71857	MAC HAIK CHRYSLER			0000		INV	05/23/2023	383465		91629		
	ACCOUNT DETAIL							LINE AMOUNT				
		1	00550410 6464					593.20				
71857	MAC HAIK CHRYSLER			0000		INV	05/23/2023	382597		91631		
	ACCOUNT DETAIL							LINE AMOUNT				
		1	00144240 6316					1,138.00				
71857	MAC HAIK CHRYSLER			0000		INV	05/23/2023	384636		91633		
	ACCOUNT DETAIL							LINE AMOUNT				
		1	00144240 6316					850.00				

City of Jackson



ACCOUNTS PAYABLE CHECK RUN REPORT

Detail Invoice List

CHECK RUN: CD062323 05/23/2023
 DUE DATE: 06/23/2023

CASH/ACCOUNT: 999 1100		POOLED CASH - AP DISBURSEMENTS									
VENDOR		REMIT	PO	TYPE	DUE DATE	INVOICE	AMOUNT	DOCUMENT	VOUCHER	CHECK	
71857	MAC HAIK CHRYSLER ACCOUNT DETAIL	0000	99230223	INV	05/23/2023	5090305 LINE AMOUNT	549.00	91634			
	1 00144240 6316			OPERATION MOTOR VEH			549.00				
71857	MAC HAIK CHRYSLER ACCOUNT DETAIL	0000	99230223	INV	05/23/2023	5090178 LINE AMOUNT	325.50	91637			
	1 00144240 6316			OPERATION MOTOR VEH			325.50				
71857	MAC HAIK CHRYSLER ACCOUNT DETAIL	0000	99230223	INV	05/23/2023	384222 LINE AMOUNT	386.09	91638			
	1 00144240 6316			OPERATION MOTOR VEH			386.09				
71857	MAC HAIK CHRYSLER ACCOUNT DETAIL	0000	99230223	INV	05/23/2023	5090664 LINE AMOUNT	304.42	91639			
	1 00144240 6316			OPERATION MOTOR VEH			304.42				
71857	MAC HAIK CHRYSLER ACCOUNT DETAIL	0000	99230223	INV	05/23/2023	386355 LINE AMOUNT	279.90	91640			
	1 00144240 6316			OPERATION MOTOR VEH			279.90				
71857	MAC HAIK CHRYSLER ACCOUNT DETAIL	0000	99230223	INV	05/23/2023	5092436 LINE AMOUNT	234.00	91642			
	1 00144240 6316			OPERATION MOTOR VEH			234.00				
71857	MAC HAIK CHRYSLER ACCOUNT DETAIL	0000	99230223	INV	05/23/2023	5091854 LINE AMOUNT	61.77	91643			
	1 00144240 6316			OPERATION MOTOR VEH			61.77				
71857	MAC HAIK CHRYSLER ACCOUNT DETAIL	0000	99230223	INV	05/26/2023	385577 LINE AMOUNT	55.16	91644			
	1 00144310 6316			TELECOMMOTOR VEH			55.16				
71857	MAC HAIK CHRYSLER ACCOUNT DETAIL	0000	99230230	INV	05/23/2023	386100 LINE AMOUNT	8,640.60	91742			
	1 00145124 6316			SBD - PAV MOTOR VEH			8,640.60				

ACCOUNTS PAYABLE CHECK RUN REPORT

Detail Invoice List

CHECK RUN: CDD052323 05/23/2023
 DUE DATE: 05/23/2023



CASH ACCOUNT:	999	1100	POOLED CASH - AP DISBURSEMENTS				INVOICE	AMOUNT	DOCUMENT	VOUCHER	CHECK
VENDOR	REMIT	PO	TYPE	DUE DATE	INVOICE	AMOUNT	DOCUMENT	VOUCHER	CHECK		
71857	MAC HAIK CHRYSLER ACCOUNT DETAIL	99230228	INV	05/23/2023	385026 LINE AMOUNT	91743					
	1 00144240 6316		OPERATION MOTOR VEH		690.00						
71857	MAC HAIK CHRYSLER ACCOUNT DETAIL	99230228	INV	05/23/2023	386100C LINE AMOUNT	91745					
	1 00145124 6316		SBD - PAV MOTOR VEH		1,890.00						
71857	MAC HAIK CHRYSLER ACCOUNT DETAIL	99230228	INV	05/23/2023	387860 LINE AMOUNT	91746					
	1 00144240 6316		OPERATION MOTOR VEH		2,202.00						
71857	MAC HAIK CHRYSLER ACCOUNT DETAIL	99230228	INV	05/23/2023	386672 LINE AMOUNT	91747					
	1 00950610 6316		LANDFILL MOTOR VEH		176.00						
71857	MAC HAIK CHRYSLER ACCOUNT DETAIL	99230229	INV	05/23/2023	5094828 LINE AMOUNT	91751					
	1 00144240 6316		OPERATION MOTOR VEH		597.82						
71857	MAC HAIK CHRYSLER ACCOUNT DETAIL	99230229	INV	05/23/2023	5095132 LINE AMOUNT	91753					
	1 00144240 6316		OPERATION MOTOR VEH		247.50						
71857	MAC HAIK CHRYSLER ACCOUNT DETAIL	99230229	INV	05/23/2023	5095958 LINE AMOUNT	91754					
	1 00144240 6316		OPERATION MOTOR VEH		266.36						
71857	MAC HAIK CHRYSLER ACCOUNT DETAIL	99230229	INV	05/23/2023	5096500 LINE AMOUNT	91755					
	1 00144240 6316		OPERATION MOTOR VEH		49.66						
71857	MAC HAIK CHRYSLER ACCOUNT DETAIL	99230229	INV	05/23/2023	5096525 LINE AMOUNT	91756					
	1 00144240 6316		OPERATION MOTOR VEH		31.64						

City of Jackson



ACCOUNTS PAYABLE CHECK RUN REPORT

Detail Invoice List

CHECK RUN: CD052323 05/23/2023
 DUE DATE: 05/23/2023

CASH ACCOUNT: 999		1100		POOLED CASH - AP DISBURSEMENTS						
VENDOR		REMIT	PO	TYPE	DUE DATE	INVOICE	AMOUNT	DOCUMENT	VOUCHER	CHECK
71857	MAC HAIK CHRYSLER	0000	99230229	INV	05/23/2023	5096534		91758		
	ACCOUNT DETAIL					LINE AMOUNT	63.28			
	1 00144240 6316			OPERATION MOTOR VEH						
71857	MAC HAIK CHRYSLER	0000	99230229	INV	05/23/2023	5096812		91759		
	ACCOUNT DETAIL					LINE AMOUNT	124.50			
	1 00144240 6316			OPERATION MOTOR VEH						
71857	MAC HAIK CHRYSLER	0000	99230229	INV	05/23/2023	5096924		91760		
	ACCOUNT DETAIL					LINE AMOUNT	308.48			
	1 00144240 6316			OPERATION MOTOR VEH						
71857	MAC HAIK CHRYSLER	0000	99230229	INV	05/23/2023	5097025		91761		
	ACCOUNT DETAIL					LINE AMOUNT	197.25			
	1 00144240 6316			OPERATION MOTOR VEH						
71857	MAC HAIK CHRYSLER	0000	99230229	INV	05/23/2023	5097136		91762		
	ACCOUNT DETAIL					LINE AMOUNT	247.50			
	1 00144240 6316			OPERATION MOTOR VEH						
71857	MAC HAIK CHRYSLER	0000	99230229	INV	05/23/2023	5097205		91763		
	ACCOUNT DETAIL					LINE AMOUNT	117.75			
	1 00144240 6316			OPERATION MOTOR VEH						
71857	MAC HAIK CHRYSLER	0000	99230229	INV	05/23/2023	5097215		91764		
	ACCOUNT DETAIL					LINE AMOUNT	489.75			
	1 00144240 6316			OPERATION MOTOR VEH						
71857	MAC HAIK CHRYSLER	0000	99230229	INV	05/23/2023	5098316		91765		
	ACCOUNT DETAIL					LINE AMOUNT	138.00			
	1 00144240 6316			OPERATION MOTOR VEH						
71857	MAC HAIK CHRYSLER	0000	99230229	INV	05/23/2023	5099354		91766		
	ACCOUNT DETAIL					LINE AMOUNT	61.31			
	1 00144240 6316			OPERATION MOTOR VEH						

City of Jackson



ACCOUNTS PAYABLE CHECK RUN REPORT

Detail Invoice List

CHECK RUN: CD062323 05/23/2023
 DUE DATE: 05/23/2023

CASH ACCOUNT:	999	1100	POOLED CASH - AP DISBURSEMENTS				INVOICE	AMOUNT	DOCUMENT	VOUCHER	CHECK
VENDOR	REMIT	PO	TYPE	DUE DATE	INVOICE	AMOUNT	DOCUMENT	VOUCHER	CHECK		
71857	MAC HAIK CHRYSLER	99230229	INV	05/23/2023	5099387	91767					
	ACCOUNT DETAIL				LINE AMOUNT						
	1 00144240 6316		OPERATION MOTOR VEH		431.25						
71857	MAC HAIK CHRYSLER	99230229	INV	05/23/2023	5099388	91768					
	ACCOUNT DETAIL				LINE AMOUNT						
	1 00144240 6316		OPERATION MOTOR VEH		431.25						
71857	MAC HAIK CHRYSLER	99230229	INV	05/23/2023	5099799	91769					
	ACCOUNT DETAIL				LINE AMOUNT						
	1 00144240 6316		OPERATION MOTOR VEH		675.00						
			CHECK TOTAL		22,853.94						
10860	MEL LUNA SAW CO	99230225	INV	05/23/2023	93802	91858					
	ACCOUNT DETAIL				LINE AMOUNT						
	1 00145125 6316		SBD - D MOTOR VEH		74.00						
10860	MEL LUNA SAW CO	99230225	INV	05/23/2023	93831	91859					
	ACCOUNT DETAIL				LINE AMOUNT						
	1 03152220 6465		OPERATION AUTO + TR		83.00						
10860	MEL LUNA SAW CO	99230225	INV	05/23/2023	93797	91860					
	ACCOUNT DETAIL				LINE AMOUNT						
	1 00145125 6316		SBD - D MOTOR VEH		61.00						
10860	MEL LUNA SAW CO	99230225	INV	05/23/2023	93793	91861					
	ACCOUNT DETAIL				LINE AMOUNT						
	1 00145125 6316		SBD - D MOTOR VEH		93.00						
10860	MEL LUNA SAW CO	99230225	INV	05/23/2023	93798	91862					
	ACCOUNT DETAIL				LINE AMOUNT						
	1 00145125 6316		SBD - D MOTOR VEH		79.00						
10860	MEL LUNA SAW CO	99230225	INV	05/23/2023	94058	91863					
	ACCOUNT DETAIL				LINE AMOUNT						
	1 03152220 6316		OPERATION MOTOR VEH		14.90						

Report generated: 05/19/2023 10:26:37
 User: Gloria Jones (glorhaj)
 Program ID: apwarrnl

City of Jackson



ACCOUNTS PAYABLE CHECK RUN REPORT

Detail Invoice List

CHECK RUN: CD052323 05/23/2023
 DUE DATE: 05/23/2023

CASH ACCOUNT: 999		1100		POOLED CASH - AP DISBURSEMENTS						
VENDOR	REMIT	PO	TYPE	DUPLICATE	DUPLICATE	DUPLICATE	DUPLICATE	DUPLICATE	DUPLICATE	
10860	MEL LUNA SAW CO	99230225	INV	05/23/2023	94059	LINE AMOUNT				
	ACCOUNT DETAIL									
	1 03152220 6465		OPERATION AUTO + TR			42.90				
							42.90		91865	
10860	MEL LUNA SAW CO	99230225	INV	05/23/2023	93804	LINE AMOUNT				
	ACCOUNT DETAIL									
	1 03152220 6465		OPERATION AUTO + TR			91.47				
							91.47			
							539.27		91865	
400158	METRIX SOLUTIONS, LLC	23001163	EFT	05/23/2023	M91837	LINE AMOUNT				
	ACCOUNT DETAIL									
	1 00144210 6242		OFFICE OF DATA PROCE			10,832.90				
	2 00144240 6422		OPERATION FREIGHT E			30.00				
							10,862.90			
							10,862.90		91554	
52712	METRO JACKSON CONVENT		EFT	05/23/2023	05122023-1	LINE AMOUNT				
	ACCOUNT DETAIL									
	1 20355900 6771		JXN CONVE APPROP. C			333,480.60				
							333,480.60			
							333,480.60		91818	
401528	METROPOLITAN LIFE INS		INV	05/23/2023	050120230104321	LINE AMOUNT				
	ACCOUNT DETAIL									
	1 05755830 6495		LIFE INSU LIFE INS			6,839.20				
							6,839.20			
							6,839.20		91309	
11058	MID-SOUTH UNIFORM & S	23001239	EFT	05/23/2023	639421	LINE AMOUNT				
	ACCOUNT DETAIL									
	1 00144160 6217		FIRE VEHI UNIFORMS			443.60				
							443.60			
							443.60		91595	
401442	MILLER & CORY, PA		INV	05/23/2023	3817	LINE AMOUNT				
	ACCOUNT DETAIL									
	1 00140794 6414		CLAIMS (O SPECIAL L			885.00				
							885.00			
									91409	

Report generated: 05/18/2023 10:26:37
 User: Gloria Jones (gloriaj)
 Program ID: apwarrn1

City of Jackson



ACCOUNTS PAYABLE CHECK RUN REPORT

Detail Invoice List

CHECK RUN: CD052323 05/23/2023
 DUE DATE: 05/23/2023

VENDOR	CASH ACCOUNT: 999	1100	REMIT	PO	TYPE	DUE DATE	INVOICE	AMOUNT	DOCUMENT	VOUCHER	CHECK
401442	MILLER & CORY, PA		0000		INV	05/23/2023	3771	885.00	91583		
	ACCOUNT DETAIL						LINE AMOUNT				
	1 00140700 6414			LEGAL	SPECIAL L		258.45				
401442	MILLER & CORY, PA		0000		INV	05/23/2023	3770	258.45	91584		
	ACCOUNT DETAIL						LINE AMOUNT				
	1 00140794 6419			CLAIMS (O	OTHER PRO		80.00				
							CHECK TOTAL	1,223.45			
60427	MIPCO IMPRESSION PROD		0000		INV	05/23/2023	190879	82178			
	ACCOUNT DETAIL						LINE AMOUNT				
	1 00143300 6514			SPECIAL P	RENTAL OF		1,622.99				
60427	MIPCO IMPRESSION PROD		0000		INV	05/23/2023	195819	82179			
	ACCOUNT DETAIL						LINE AMOUNT				
	1 00143300 6514			SPECIAL P	RENTAL OF		1,209.54				
60427	MIPCO IMPRESSION PROD		0000		INV	05/23/2023	231676	89908			
	ACCOUNT DETAIL						LINE AMOUNT				
	1 00149700 6514			INTERNAL	RENTAL OF		161.11				
60427	MIPCO IMPRESSION PROD		0000		INV	05/23/2023	233906	91254			
	ACCOUNT DETAIL						LINE AMOUNT				
	1 00144470 6514			COMMUNITY	RENTAL OF		492.30				
60427	MIPCO IMPRESSION PROD		0000		INV	05/23/2023	233920	91323			
	ACCOUNT DETAIL						LINE AMOUNT				
	1 00145010 6514			PUBLIC WQ	RENTAL OF		458.33				
60427	MIPCO IMPRESSION PROD		0000		INV	05/23/2023	233917	91329			
	ACCOUNT DETAIL						LINE AMOUNT				
	1 00140193 6514			MAYOR LUM	RENTAL OF		234.79				
60427	MIPCO IMPRESSION PROD		0000		INV	05/23/2023	234278	91399			
	ACCOUNT DETAIL						LINE AMOUNT				
	1 00144224 6514			ADMINISTR	RENTAL OF		353.67				

Report generated: 05/18/2023 10:26:37
 User: Gloria Jones (gloria)
 Program ID: apwarnt

City of Jackson



ACCOUNTS PAYABLE CHECK RUN REPORT

Detail Invoice List

CHECK RUN: CD052323 05/23/2023
 DUE DATE: 05/23/2023

VENDOR	CASH ACCOUNT: 999	1100	REMIT	PO	TYPE	DUE DATE	INVOICE	AMOUNT	DOCUMENT	VOUCHER	CHECK
60427	MIPCO IMPRESSION PROD	0000			INV	05/23/2023	234279	353.67	91406		
	ACCOUNT DETAIL						LINE AMOUNT				
	1 00144224 6514						6,376.74				
	ADMINISTR RENTAL OF							6,376.74	91511		
60427	MIPCO IMPRESSION PROD	0000			INV	05/23/2023	233918				
	ACCOUNT DETAIL						LINE AMOUNT				
	1 00145110 6514						137.21				
	STREETS/B RENTAL OF							137.21	91548		
60427	MIPCO IMPRESSION PROD	0000			INV	05/23/2023	233922				
	ACCOUNT DETAIL						LINE AMOUNT				
	1 00142800 6514						486.36				
	MUNI CLERK RENTAL OF							486.36	91585		
60427	MIPCO IMPRESSION PROD	0000			INV	05/23/2023	234036				
	ACCOUNT DETAIL						LINE AMOUNT				
	1 00149700 6514						159.28				
	INTERNAL RENTAL OF							159.28	91648		
60427	MIPCO IMPRESSION PROD	0000			INV	05/23/2023	233914				
	ACCOUNT DETAIL						LINE AMOUNT				
	1 03152215 6514						103.85				
	MAINTENAN RENTAL OF							103.85	91651		
60427	MIPCO IMPRESSION PROD	0000			INV	05/23/2023	233907				
	ACCOUNT DETAIL						LINE AMOUNT				
	1 00145124 6514						165.20				
	SBD - PAV RENTAL OF							165.20	91658		
60427	MIPCO IMPRESSION PROD	0000			INV	05/23/2023	233904				
	ACCOUNT DETAIL						LINE AMOUNT				
	1 00140200 6514						512.74				
	CLERKCNCL RENTAL OF							512.74	91660		
60427	MIPCO IMPRESSION PROD	0000			INV	05/23/2023	233903				
	ACCOUNT DETAIL						LINE AMOUNT				
	1 00140200 6514						208.78				
	CLERKCNCL RENTAL OF							208.78	91685		
60427	MIPCO IMPRESSION PROD	0000			INV	05/23/2023	233913				
	ACCOUNT DETAIL						LINE AMOUNT				
	1 00140790 6514						336.13				
	RISK MANA RENTAL OF							336.13			

Report generated: 05/18/2023 10:26:37
 User: Gloria Jones (glornaj)
 Program ID: apwarrnl



ACCOUNTS PAYABLE CHECK RUN REPORT

Detail Invoice List

CHECK RUN: CD052323 05/23/2023
 DUE DATE: 05/23/2023

CASH ACCOUNT	999	1100	REMIT	PO	TYPE	DUE DATE	INVOICE	AMOUNT	DOCUMENT	VOUCHER	CHECK
60427	MIPCO IMPRESSION PROD	0000	INV		05/23/2023	233908			91771		
	ACCOUNT DETAIL					LINE AMOUNT					
	1 38271530 6514					457.45		457.45			
60427	MIPCO IMPRESSION PROD	0000	INV		05/23/2023	234117			91827		
	ACCOUNT DETAIL					LINE AMOUNT					
	1 00140410 6514					83.85					
	2 00141130 6514					83.85		167.70			
60427	MIPCO IMPRESSION PROD	0000	INV		05/23/2023	232440			91837		
	ACCOUNT DETAIL					LINE AMOUNT					
	1 00143300 6514					1,784.97		1,784.97			
	CDBG CARE/RENTAL OF					CHECK TOTAL		15,429.14			
61128	MISSISSIPPI LINK THE	0000	INV		05/23/2023	26489			91404		
	ACCOUNT DETAIL					LINE AMOUNT					
	1 18756520 6444					92.40		92.40			
	TRANSPIT S LEGAL ADS					CHECK TOTAL		92.40			
72980	MISSISSIPPI YARD BARB	0000	INV		05/23/2023	1868			91545		
	ACCOUNT DETAIL					LINE AMOUNT					
	1 18756510 6461					2,810.00		2,810.00			
	JATRAN-OP BUILDINGS					CHECK TOTAL		2,810.00			
69198	MORRIS & MCDANIEL	0000	EFT		05/23/2023	23,801			91250		
	ACCOUNT DETAIL					LINE AMOUNT					
	1 00144140 6419					800.00		800.00			
	HUMAN RES OTHER PRO					CHECK TOTAL		800.00			
68265	MS DEPARTMENT OF HEAL	0000	INV		05/23/2023	23-132834			91284		
	ACCOUNT DETAIL					LINE AMOUNT					
	1 00141910 6464					90.00					
	FIRE STAT OTHER PRO					30.00					
	2 00144170 6419					60.00					
	CARE & MA MACHINE/E					CHECK TOTAL		91284			

Report generated: 05/19/2023 10:26:37
 User: Gloria Jones (ljon19j)
 Program ID: apwerrrrr

City of Jackson



ACCOUNTS PAYABLE CHECK RUN REPORT

Detail Invoice List

CHECK RUN: CD052323 05/23/2023
 DUE DATE: 05/23/2023

VENDOR	CASH ACCOUNT	999	1100	REMIT	PO	TYPE	DUE DATE	INVOICE	AMOUNT	DOCUMENT	VOUCHER	CHECK
68265	MS DEPARTMENT OF HEAL			0000	77230527	INV	05/23/2023	23-132936	180.00	91285		
	ACCOUNT DETAIL							LINE AMOUNT				
	1 00143420 6317							30.00				
	2 00550125 6419							30.00				
								CHECK TOTAL	60.00			
									240.00			
65810	MS DEPT OF PUBLIC SAF			0000		INV	05/23/2023	04302023-2	91208			
	ACCOUNT DETAIL							LINE AMOUNT				
	1 001 2379							3,400.00				
								CHECK TOTAL	3,400.00			
65810	MS DEPT OF PUBLIC SAF			0000		INV	05/23/2023	04302023-3	91209			
	ACCOUNT DETAIL							LINE AMOUNT				
	1 001 2397							114.90				
								CHECK TOTAL	114.90			
11540	MS INDUSTRIES FOR THE			0000	23001112	INV	05/23/2023	0057069-1N	89597			
	ACCOUNT DETAIL							LINE AMOUNT				
	1 00140193 6218							286.39				
								CHECK TOTAL	286.39			
62983	MULTI-CON, INC			0000		EFT	05/23/2023	INVOICE-COJ-358	91669			
	ACCOUNT DETAIL							LINE AMOUNT				
	1 08596430 6485							6,032.00				
	2 08596440 6485							20,733.00				
	3 08596410 6734							3,000.00				
								CHECK TOTAL	29,765.00			
								CHECK TOTAL	29,765.00			
71606	MUNICIPAL EMERGENCY S			0000	23000795	INV	05/23/2023	IN1851198	90461			
	ACCOUNT DETAIL							LINE AMOUNT				
	1 00144120 6240							3,776.00				
								CHECK TOTAL	3,776.00			

Report generated: 05/19/2023 10:28:37
 User: Gloria Jones (gloriaj)
 Program ID: apwarrnl



City of Jackson

ACCOUNTS PAYABLE CHECK RUN REPORT

Detail Invoice List

CHECK RUN: CD052323 05/23/2023
DUE DATE: 05/23/2023

VENDOR	CASH ACCOUNT	999	1100	REMIT	PO	TYPE	DUE DATE	INVOICE	AMOUNT	DOCUMENT	VOUCHER	CHECK
61831	NAPA AUTO PARTS			0000	88230190	EFT	05/23/2023	461233		91671		
	ACCOUNT DETAIL							CHECK TOTAL	3,776.00			
	1 00144120 6316					EMERGENCMOTOR VEH		LINE AMOUNT				
								18.87				
61831	NAPA AUTO PARTS			0000	88230197	EFT	05/23/2023	461801		91678		
	ACCOUNT DETAIL							CHECK TOTAL	125.04			
	1 00144120 6316					EMERGENCMOTOR VEH		LINE AMOUNT	143.91			
								CHECK TOTAL	143.91			
401943	NATIONAL STORMWATER C			0000		INV	05/23/2023	05032023		90910		
	ACCOUNT DETAIL							CHECK TOTAL	824.00			
	1 00145010 6443					PUBLIC WO DUES, MEM.		LINE AMOUNT	824.00			
								CHECK TOTAL	824.00			
70072	OFFICE DEPOT #414			0000	23001187	INV	05/23/2023	310957736001		91265		
	ACCOUNT DETAIL							CHECK TOTAL	13.99			
	1 00146110 6218					P W-DEPUT OFFICE SU		LINE AMOUNT	13.99			
								CHECK TOTAL	10.99			
70072	OFFICE DEPOT #414			0000	23001203	INV	05/23/2023	311858626001		91267		
	ACCOUNT DETAIL							CHECK TOTAL	369.99			
	1 00146110 6218					P W-DEPUT OFFICE SU		LINE AMOUNT	369.99			
								CHECK TOTAL	424.64			
70072	OFFICE DEPOT #414			0000	23001187	INV	05/23/2023	310955515001		91392		
	ACCOUNT DETAIL							CHECK TOTAL	49.44			
	1 00146110 6218					P W-DEPUT OFFICE SU		LINE AMOUNT	49.44			

Report generated: 05/18/2023 10:26:37
User: Gloria Jones (gloriej)
Program ID: apwarrnt

City of Jackson



ACCOUNTS PAYABLE CHECK RUN REPORT

Detail Invoice List

CHECK RUN: CD052323 05/23/2023
 DUE DATE: 05/23/2023

CASH ACCOUNT: 999		1100		POOLED CASH - AP DISBURSEMENTS									
VENDOR		REMIT	PO	TYPE	DUE DATE	INVOICE	AMOUNT	DOCUMENT	VOUCHER	CHECK			
70072	OFFICE DEPOT #414	0000	23001176	INV	05/23/2023	310699342001							
	ACCOUNT DETAIL					LINE AMOUNT							
	1 00145610 6218					105.63							
70072	OFFICE DEPOT #414	0000	23000696	INV	05/23/2023	288289110001							
	ACCOUNT DETAIL					LINE AMOUNT							
	1 00145610 6218					284.19							
70072	OFFICE DEPOT #414	0000	23000696	INV	05/23/2023	287690147001							
	ACCOUNT DETAIL					LINE AMOUNT							
	1 00145610 6218					519.79							
70072	OFFICE DEPOT #414	0000	23000696	INV	05/23/2023	287690137001							
	ACCOUNT DETAIL					LINE AMOUNT							
	1 00145610 6218					83.79							
70072	OFFICE DEPOT #414	0000	23000696	INV	05/23/2023	287690056001							
	ACCOUNT DETAIL					LINE AMOUNT							
	1 00145610 6218					59.99							
70072	OFFICE DEPOT #414	0000	99230215	INV	05/23/2023	288275376001							
	ACCOUNT DETAIL					LINE AMOUNT							
	1 00145610 6218					223.37							
70072	OFFICE DEPOT #414	0000	99230216	INV	05/23/2023	305245069001							
	ACCOUNT DETAIL					LINE AMOUNT							
	1 00145610 6218					191.67							
70072	OFFICE DEPOT #414	0000	99230217	INV	05/23/2023	287690144001							
	ACCOUNT DETAIL					LINE AMOUNT							
	1 00145610 6218					1,183.89							

City of Jackson



ACCOUNTS PAYABLE CHECK RUN REPORT

Detail Invoice List

CHECK RUN: CDD052323 05/23/2023
 DUE DATE: 05/23/2023

CASH ACCOUNT	999	1100	REMIT	PO	TYPE	DUE DATE	INVOICE	AMOUNT	DOCUMENT	VOUCHER	CHECK
70072	OFFICE DEPOT #414	0000	23000914	INV	05/23/2023	309076463001	91576				
	ACCOUNT DETAIL					LINE AMOUNT					
	1 00140720 6218					229.00		229.00	91692		
70072	OFFICE DEPOT #414	0000	23000789	INV	05/23/2023	286423137001	91692				
	ACCOUNT DETAIL					LINE AMOUNT					
	1 03152220 6218					12.46					
	2 03152225 6213					108.04					
	306.57										
	CHECK TOTAL					4,591.23					
70072	OFFICE DEPOT #414	0000	23000789	INV	05/23/2023	286423267001	91695				
	ACCOUNT DETAIL					LINE AMOUNT					
	1 03152225 6213					88.94		88.94	91698		
70072	OFFICE DEPOT #414	0000	23000789	INV	05/23/2023	286423220001	91700				
	ACCOUNT DETAIL					LINE AMOUNT					
	1 03152220 6218					14.76		14.76	91700		
400063	ON THE WAY SERVICE, ACCOUNT DETAIL	0000	99230233	EFT	05/23/2023	2351	91800				
	1 00550410 6464					95.00		95.00	91801		
400063	ON THE WAY SERVICE, ACCOUNT DETAIL	0000	99230233	EFT	05/23/2023	2352	91802				
	1 00550410 6464					195.00		195.00	91802		
400063	ON THE WAY SERVICE, ACCOUNT DETAIL	0000	99230233	EFT	05/23/2023	2338	91802				
	1 00145124 6316					145.00		145.00	91802		

City of Jackson



ACCOUNTS PAYABLE CHECK RUN REPORT

Detail Invoice List

CHECK RUN: CD052323 05/23/2023
 DUE DATE: 05/23/2023

CASH ACCOUNT: 999		1100		POOLED CASH - AP DISBURSEMENTS						
VENDOR		REMIT	PO	TYPE	DUE DATE	INVOICE	AMOUNT	DOCUMENT	VOUCHER	CHECK
400063	ON THE WAY SERVICE, ACCOUNT DETAIL	0000	99230233	EFT	05/23/2023	2339		91803		
	1 00145124 6316			SBD - PAV MOTOR VEH		LINE AMOUNT	145.00			
							145.00			
400063	ON THE WAY SERVICE, ACCOUNT DETAIL	0000	99230233	EFT	05/23/2023	2316		91805		
	1 00145125 6316			SBD - D MOTOR VEH		LINE AMOUNT	135.00			
							135.00			
400063	ON THE WAY SERVICE, ACCOUNT DETAIL	0000	99230233	EFT	05/23/2023	2340		91806		
	1 00145124 6316			SBD - PAV MOTOR VEH		LINE AMOUNT	145.00			
							145.00			
400063	ON THE WAY SERVICE, ACCOUNT DETAIL	0000	99230233	EFT	05/23/2023	2312		91808		
	1 00145124 6316			SBD - PAV MOTOR VEH		LINE AMOUNT	110.00			
							110.00			
							970.00			
							970.00			
999993	ADU BOATENG ACCOUNT DETAIL	0000		INV	05/23/2023	14873		91569		
	1 01851820 6722			STATE TOR CLAIMS AG		LINE AMOUNT	175.00			
							175.00			
							175.00			
999993	ARTESIA PORTER ACCOUNT DETAIL	0000		INV	05/23/2023	14758		91564		
	1 01851820 6722			STATE TOR CLAIMS AG		LINE AMOUNT	675.00			
							675.00			
							675.00			
999993	COMEBACK PROPERTY GRO ACCOUNT DETAIL	0000		INV	05/23/2023	14829		91809		
	1 01851820 6722			STATE TOR CLAIMS AG		LINE AMOUNT	4,427.03			
							4,427.03			
							4,427.03			

City of Jackson



ACCOUNTS PAYABLE CHECK RUN REPORT

Detail Invoice List

CHECK RUN: CD052323 05/23/2023
 DUE DATE: 05/23/2023

CASH ACCOUNT:	999	1100	POOLED CASH - AP DISBURSEMENTS																	
VENDOR	REMIT	PO	TYPE	DUE DATE	INVOICE	AMOUNT	DOCUMENT	VOUCHER	CHECK											
999993	DONALD FRAZIER		INV	05/23/2023	14879	85.00	91568													
	ACCOUNT DETAIL																			
	1 01851820 6722		STATE TOR CLAIMS AG		85.00	85.00														
			CHECK TOTAL			85.00														
999993	FLETCHER WATTS		INV	05/23/2023	14863	495.00	91565													
	ACCOUNT DETAIL																			
	1 01851820 6722		STATE TOR CLAIMS AG		495.00	495.00														
			CHECK TOTAL			495.00														
999993	LORETHA HARRIS		INV	05/23/2023	14876	550.00	91561													
	ACCOUNT DETAIL																			
	1 01851820 6722		STATE TOR CLAIMS AG		550.00	550.00														
			CHECK TOTAL			550.00														
999993	MALLORIE WILSON		INV	05/23/2023	14774	750.00	91566													
	ACCOUNT DETAIL																			
	1 01851820 6722		STATE TOR CLAIMS AG		750.00	750.00														
			CHECK TOTAL			750.00														
999993	MARY ESTELL		INV	05/23/2023	14885	50.00	91563													
	ACCOUNT DETAIL																			
	1 01851820 6722		STATE TOR CLAIMS AG		50.00	50.00														
			CHECK TOTAL			50.00														
999993	SHEENA ALLEN		INV	05/23/2023	14751	715.00	91562													
	ACCOUNT DETAIL																			
	1 01851820 6722		STATE TOR CLAIMS AG		715.00	715.00														
			CHECK TOTAL			715.00														

City of Jackson



ACCOUNTS PAYABLE CHECK RUN REPORT

Detail Invoice List

CHECK RUN: CD052323 05/23/2023
 DUE DATE: 05/23/2023

CASH ACCOUNT: 999		1100		POOLED CASH - AP DISBURSEMENTS						
VENDOR	REMIT	PO	TYPE	DUE DATE	INVOICE	AMOUNT	DOCUMENT	VOUCHER	CHECK	
999993	STEVE SAMPSON		INV	05/23/2023	14926		91567			
	ACCOUNT DETAIL				LINE AMOUNT					
	1	01851820	6722		370.00					
					CHECK TOTAL	370.00				
999992	DREXEL C. ANDERSON		INV	05/23/2023	05152023		91819			
	ACCOUNT DETAIL				LINE AMOUNT					
	1	005	2332		475.00					
					CHECK TOTAL	475.00				
999992	RODRIGUS FEAZELL		INV	05/23/2023	05172023		92129			
	ACCOUNT DETAIL				LINE AMOUNT					
	1	005	2332		140.00					
					CHECK TOTAL	140.00				
999992	ROSILIN BURNS		INV	05/23/2023	05112023		91817			
	ACCOUNT DETAIL				LINE AMOUNT					
	1	005	2332		50.00					
					CHECK TOTAL	50.00				
999998	Anthony Warren		INV	05/23/2023	05052023		91554			
	ACCOUNT DETAIL				LINE AMOUNT					
	1	001	5666		32.00					
					CHECK TOTAL	32.00				
999997	Michael Davis		INV	05/23/2023	1175177		90909			
	ACCOUNT DETAIL				LINE AMOUNT					
	1	00142610	6443		370.00					
					CHECK TOTAL	370.00				

City of Jackson



ACCOUNTS PAYABLE CHECK RUN REPORT

Detail Invoice List

CHECK RUN: CD052323 05/23/2023
 DUE DATE: 05/23/2023

CASH/ACCOUNT:		999	1100	POOLED CASH - AP DISBURSEMENTS				INVOICE	AMOUNT	DOCUMENT	VOUCHER	CHECK
VENDOR				REMIT	PO	TYPE	DUE DATE					
6371	PETTY CASH-FINANCE/TR			0000		EFT	05/23/2023	16411		90124		
	ACCOUNT DETAIL							LINE AMOUNT				
	1 00141600 6473							1,872.25				
6371	PETTY CASH-FINANCE/TR			0000		EFT	05/23/2023	16407		90222		
	ACCOUNT DETAIL							LINE AMOUNT				
	1 00141600 6473							1,925.41				
6371	PETTY CASH-FINANCE/TR			0000		EFT	05/23/2023	16409		90354		
	ACCOUNT DETAIL							LINE AMOUNT				
	1 00141600 6473							66.87				
6371	PETTY CASH-FINANCE/TR			0000		EFT	05/23/2023	16429		90360		
	ACCOUNT DETAIL							LINE AMOUNT				
	1 00141600 6473							1,872.25				
6371	PETTY CASH-FINANCE/TR			0000		EFT	05/23/2023	16412		90372		
	ACCOUNT DETAIL							LINE AMOUNT				
	1 00140200 6443							555.00				
6371	PETTY CASH-FINANCE/TR			0000		EFT	05/23/2023	16436		90376		
	ACCOUNT DETAIL							LINE AMOUNT				
	1 00140200 6473							257.60				
6371	PETTY CASH-FINANCE/TR			0000		EFT	05/23/2023	16440		90435		
	ACCOUNT DETAIL							LINE AMOUNT				
	1 00141600 6473							375.00				
6371	PETTY CASH-FINANCE/TR			0000		EFT	05/23/2023	16470		90475		
	ACCOUNT DETAIL							LINE AMOUNT				
	1 08596410 6443							349.50				
6371	PETTY CASH-FINANCE/TR			0000		EFT	05/23/2023	16438		90483		
	ACCOUNT DETAIL							LINE AMOUNT				
	1 00140200 6473							257.60				

Report generated: 05/18/2023 10:26:37
 User: Gloria Jones (glotkj)
 Program ID: apwarrrk

City of Jackson



ACCOUNTS PAYABLE CHECK RUN REPORT

Detail Invoice List

CHECK RUN: CD052323 05/23/2023
 DUE DATE: 05/23/2023

CASH/ACCOUNT:		999 1100		POOLED CASH - AP DISBURSEMENTS						
VENDOR		REMIT	PO	TYPE	DUE DATE	INVOICE	AMOUNT	DOCUMENT	VOUCHER	CHECK
6371	PETTY CASH-FINANCE/TR	0000		EFT	05/23/2023	16437		90496		
	ACCOUNT DETAIL					LINE AMOUNT				
	1 00141600 6473					354.20				
6371	PETTY CASH-FINANCE/TR	0000		EFT	05/23/2023	16475		90512		
	ACCOUNT DETAIL					LINE AMOUNT				
	1 00140200 6473					113.92				
6371	PETTY CASH-FINANCE/TR	0000		EFT	05/23/2023	16478		90663		
	ACCOUNT DETAIL					LINE AMOUNT				
	1 18756520 6473					94.71				
6371	PETTY CASH-FINANCE/TR	0000		EFT	05/23/2023	16474		90692		
	ACCOUNT DETAIL					LINE AMOUNT				
	1 00141600 6473					110.35				
6371	PETTY CASH-FINANCE/TR	0000		EFT	05/23/2023	16410		90701		
	ACCOUNT DETAIL					LINE AMOUNT				
	1 00140200 6473					1,134.56				
6371	PETTY CASH-FINANCE/TR	0000		EFT	05/23/2023	16477		90711		
	ACCOUNT DETAIL					LINE AMOUNT				
	1 08580920 6443					1,095.00				
6371	PETTY CASH-FINANCE/TR	0000		EFT	05/23/2023	16472		90719		
	ACCOUNT DETAIL					LINE AMOUNT				
	1 08580920 6474					1,456.40				
6371	PETTY CASH-FINANCE/TR	0000		EFT	05/23/2023	16492		90724		
	ACCOUNT DETAIL					LINE AMOUNT				
	1 18756520 6473					31.45				
6371	PETTY CASH-FINANCE/TR	0000		EFT	05/23/2023	16481		90728		
	ACCOUNT DETAIL					LINE AMOUNT				
	1 08580920 6473					1,872.64				
	2 08580910 6473					936.32				
							2,808.96			

Report generated: 05/18/2023 10:26:37
 User: Gloria Jones (gportal)
 Program ID: apwarnr



City of Jackson

ACCOUNTS PAYABLE CHECK RUN REPORT

Detail Invoice List

CHECK RUN: CD052323 05/23/2023
 DUE DATE: 05/23/2023

VENDOR	CASH ACCOUNT	999	1100	REMIT	PO	TYPE	DUE DATE	INVOICE	AMOUNT	DOCUMENT	VOUCHER	CHECK
6371	PETTY CASH-FINANCE/TR			0000		EFT	05/23/2023	16484		90738		
	ACCOUNT DETAIL							LINE AMOUNT				
	1 08580920 6443					OFFICE OF DUES, MEM.		1,095.00				
	2 08596410 6443					LEAD-BASE DUES, MEM.		1,095.00				
	3 08596410 6443					LEAD-BASE DUES, MEM.		945.00				
	4 08580910 6443					CDBG ADMI DUES, MEM.		1,095.00				
6371	PETTY CASH-FINANCE/TR			0000		EFT	05/23/2023	16418A		90819		
	ACCOUNT DETAIL							LINE AMOUNT				
	1 08580910 6474					CDBG ADMI AIR TRAVEL		1,412.82				
	2 08580920 6474					OFFICE OF AIR TRAVEL		1,186.80				
	3 08580910 6474					CDBG ADMI AIR TRAVEL		706.41				
6371	PETTY CASH-FINANCE/TR			0000		EFT	05/23/2023	16505		91218		
	ACCOUNT DETAIL							LINE AMOUNT				
	1 00141600 6473					CITY COUN TRAVEL EXP		193.20				
6371	PETTY CASH-FINANCE/TR			0000		EFT	05/23/2023	16509		91220		
	ACCOUNT DETAIL							LINE AMOUNT				
	1 00144470 6473					COMMUNITY TRAVEL EXP		293.63				
6371	PETTY CASH-FINANCE/TR			0000		EFT	05/23/2023	16506		91221		
	ACCOUNT DETAIL							LINE AMOUNT				
	1 00144210 6473					OFFICE OF TRAVEL EXP		554.20				
6371	PETTY CASH-FINANCE/TR			0000		EFT	05/23/2023	16510		91222		
	ACCOUNT DETAIL							LINE AMOUNT				
	1 00144470 6473					COMMUNITY TRAVEL EXP		337.82				
6371	PETTY CASH-FINANCE/TR			0000		EFT	05/23/2023	16496		91226		
	ACCOUNT DETAIL							LINE AMOUNT				
	1 00144470 6473					COMMUNITY TRAVEL EXP		530.85				
6371	PETTY CASH-FINANCE/TR			0000		EFT	05/23/2023	16498		91228		
	ACCOUNT DETAIL							LINE AMOUNT				
	1 00141600 6473					CITY COUN TRAVEL EXP		226.91				

City of Jackson



ACCOUNTS PAYABLE CHECK RUN REPORT

Detail Invoice List

CHECK RUN: CD052323 05/23/2023
 DUE DATE: 05/23/2023

CASH ACCOUNT: 999		1100		POOLED CASH - AP DISBURSEMENTS									
VENDOR		REMIT	PO	TYPE	DUE DATE	INVOICE	AMOUNT	DOCUMENT	VOUCHER	CHECK			
6371	PETTY CASH-FINANCE/TR	0000		EFT	05/23/2023	16500		91230					
	ACCOUNT DETAIL					LINE AMOUNT							
	1 18756520 6473			TRANSIT S TRAVEL EXP		77.77							
6371	PETTY CASH-FINANCE/TR	0000		EFT	05/23/2023	16499		91231					
	ACCOUNT DETAIL					LINE AMOUNT							
	1 00140700 6476			LEGAL LOCAL TRAV		389.80							
6371	PETTY CASH-FINANCE/TR	0000		EFT	05/23/2023	16495		91234					
	ACCOUNT DETAIL					LINE AMOUNT							
	1 08596410 6443			LEAD-BASE DUES, MEM.		150.00							
6371	PETTY CASH-FINANCE/TR	0000		EFT	05/23/2023	16504		91235					
	ACCOUNT DETAIL					LINE AMOUNT							
	1 00140720 6443			OFFICE OF DUES, MEM.		75.00							
6371	PETTY CASH-FINANCE/TR	0000		EFT	05/23/2023	16503		91236					
	ACCOUNT DETAIL					LINE AMOUNT							
	1 00144210 6443			OFFICE OF DUES, MEM.		350.00							
6371	PETTY CASH-FINANCE/TR	0000		EFT	05/23/2023	16514		91238					
	ACCOUNT DETAIL					LINE AMOUNT							
	1 00140794 6419			CLAIMS (O OTHER PRO		50.00							
6371	PETTY CASH-FINANCE/TR	0000		EFT	05/23/2023	16513		91239					
	ACCOUNT DETAIL					LINE AMOUNT							
	1 00140193 6473			MAYOR LUM TRAVEL EXP		610.06							
6371	PETTY CASH-FINANCE/TR	0000		EFT	05/23/2023	16512		91240					
	ACCOUNT DETAIL					LINE AMOUNT							
	1 00140193 6473			MAYOR LUM TRAVEL EXP		540.06							
6371	PETTY CASH-FINANCE/TR	0000		EFT	05/23/2023	16501		91242					
	ACCOUNT DETAIL					LINE AMOUNT							
	1 00144210 6473			OFFICE OF TRAVEL EXP		619.92							



City of Jackson

ACCOUNTS PAYABLE CHECK RUN REPORT

Detail Invoice List

CHECK RUN: CD052323 05/23/2023
 DUE DATE: 05/23/2023

VENDOR	CASH ACCOUNT	999	1100	REMIT	PO	TYPE	DUE DATE	INVOICE	AMOUNT	DOCUMENT	VOUCHER	CHECK
6371	PETTY CASH-FINANCE/TR			0000		EFT	05/23/2023	16530		91614		
	ACCOUNT DETAIL							LINE AMOUNT				
		1	18756520			TRANSIT S AIR TRAVEL		799.49				
		2	18756520			TRANSIT S AIR TRAVEL		799.49				
									1,598.98			
6371	PETTY CASH-FINANCE/TR			0000		EFT	05/23/2023	16520		91615		
	ACCOUNT DETAIL							LINE AMOUNT				
		1	00141600			CITY COUN TRAVEL EXP		326.88				
6371	PETTY CASH-FINANCE/TR			0000		EFT	05/23/2023	16528		91618		
	ACCOUNT DETAIL							LINE AMOUNT				
		1	18756520			TRANSIT S DUES, MEM.		795.00				
									795.00			
6371	PETTY CASH-FINANCE/TR			0000		EFT	05/23/2023	16527		91620		
	ACCOUNT DETAIL							LINE AMOUNT				
		1	00144210			OFFICE OF DUES, MEM.		100.00				
									100.00			
6371	PETTY CASH-FINANCE/TR			0000		EFT	05/23/2023	16526		91622		
	ACCOUNT DETAIL							LINE AMOUNT				
		1	00144210			OFFICE OF DUES, MEM.		100.00				
									100.00			
6371	PETTY CASH-FINANCE/TR			0000		EFT	05/23/2023	16525		91625		
	ACCOUNT DETAIL							LINE AMOUNT				
		1	00144210			OFFICE OF DUES, MEM.		100.00				
									100.00			
6371	PETTY CASH-FINANCE/TR			0000		EFT	05/23/2023	16524		91627		
	ACCOUNT DETAIL							LINE AMOUNT				
		1	00144210			OFFICE OF DUES, MEM.		100.00				
									100.00			
6371	PETTY CASH-FINANCE/TR			0000		EFT	05/23/2023	16523		91628		
	ACCOUNT DETAIL							LINE AMOUNT				
		1	00144210			OFFICE OF DUES, MEM.		100.00				
									100.00			
6371	PETTY CASH-FINANCE/TR			0000		EFT	05/23/2023	16521		91632		
	ACCOUNT DETAIL							LINE AMOUNT				
		1	00144210			OFFICE OF DUES, MEM.		100.00				
									100.00			

Report generated: 05/19/2023 10:26:37
 User: Gloria Jones (gloriaj)
 Program ID: apwarrnt

City of Jackson



ACCOUNTS PAYABLE CHECK RUN REPORT

Detail Invoice List

CHECK RUN: CD052323 05/23/2023
 DUE DATE: 05/23/2023

CASH ACCOUNT	999	1100	POOLED CASH - AP DISBURSEMENTS				INVOICE	AMOUNT	DOCUMENT	VOUCHER	CHECK
VENDOR	REMIT	PO	TYPE	DUE DATE	INVOICE	AMOUNT	DOCUMENT	VOUCHER	CHECK		
6371	PETTY CASH-FINANCE/TR	0000	EFT	05/23/2023	16529	795.00	91635				
	ACCOUNT DETAIL					795.00					
	1 18756520 6443		TRANSIT S DUES, MEM.								
						CHECK TOTAL	31,392.14				
72887	PHOENIX MEDIA GROUP L	0000	INV	05/23/2023	00028	500.00	91579				
	ACCOUNT DETAIL					500.00					
	1 00550110 6419		ADMIN PAR OTHER PRO								
						CHECK TOTAL	500.00				
401522	POWERS OF MISSISSIPPI	0000	INV	05/23/2023	206329	270.00	91623				
	ACCOUNT DETAIL					270.00					
	1 00145300 6461		CARE & MA BUILDINGS								
						CHECK TOTAL	270.00				
401522	POWERS OF MISSISSIPPI	0000	INV	05/23/2023	211332	4,989.00	91679				
	ACCOUNT DETAIL					4,989.00					
	1 00144226 6419		STANDARDS OTHER PRO								
						CHECK TOTAL	4,989.00				
401522	POWERS OF MISSISSIPPI	0000	INV	05/23/2023	206316	540.00	91886				
	ACCOUNT DETAIL					540.00					
	1 00144224 6461		ADMINISTR BUILDINGS								
						CHECK TOTAL	5,799.00				
73191	PUBLIC EMPLOYEE RETIR	0000	INV	05/23/2023	05122023	762.84	91822				
	ACCOUNT DETAIL					762.84					
	1 079 2250		PAYROLL F EMPL WITH								
						CHECK TOTAL	762.84				

Report generated: 05/18/2023 10:26:37
 User: Gloria Jones (ghnja)
 Program ID: apwerrnt



City of Jackson

ACCOUNTS PAYABLE CHECK RUN REPORT

Detail Invoice List

CHECK RUN: CD0052323 05/23/2023
 DUE DATE: 05/23/2023

CASH ACCOUNT	999	1100	REMIT	PO	TYPE	DUE DATE	INVOICE	AMOUNT	DOCUMENT	VOUCHER	CHECK
VENDOR	70043	RETRO METRO LLC	0000		EFT	05/23/2023	60123		91821		
ACCOUNT DETAIL											
	1	03152010	6923		WATER/SEWLEASE PUR		13,184.25				
	2	03152010	6612		WATER/SEWINTEREST		2,511.29				
	3	00144242	6923		PRECINCT LEASE PUR		3,533.56				
	4	00144242	6612		PRECINCT INTEREST		673.06				
	5	30044346	6923		P.A./G.A. LEASE PUR		6,124.67				
	6	30044346	6612		P.A./G.A. INTEREST		1,166.61				
	7	00550110	6923		ADMIN PAR LEASE PUR		2,548.62				
	8	00550110	6612		ADMIN PAR INTEREST		485.45				
	9	00141300	6923		PERSONNELLEASE PUR		3,417.24				
	10	00141300	6612		PERSONNELINTEREST		650.90				
	11	00143300	6923		SPECIAL P LEASE PUR		7,204.33				
	12	00143300	6612		SPECIAL P INTEREST		1,372.25				
CHECK TOTAL								42,872.23			
14420	REVELL HARDWARE COMPA	0000	77230523		EFT	05/23/2023	258865/1		91274		
ACCOUNT DETAIL											
	1	00550126	6299		ATHLETICS OTHER OPE		9.95				
ACCOUNT DETAIL											
14420	REVELL HARDWARE COMPA	0000	99230170		EFT	05/23/2023	125892/7		91357		
ACCOUNT DETAIL											
	1	00145125	6316		SBD - D MOTOR VEH		416.94				
14420	REVELL HARDWARE COMPA	0000	99230170		EFT	05/23/2023	124779/7		91359		
ACCOUNT DETAIL											
	1	00145125	6316		SBD - D MOTOR VEH		87.38				
14420	REVELL HARDWARE COMPA	0000	99230170		EFT	05/23/2023	124780/7		91360		
ACCOUNT DETAIL											
	1	00145125	6316		SBD - D MOTOR VEH		87.38				
14420	REVELL HARDWARE COMPA	0000	99230170		EFT	05/23/2023	124781/7		91361		
ACCOUNT DETAIL											
	1	00145125	6316		SBD - D MOTOR VEH		127.28				

Report generated: 05/18/2023 10:26:37
 User: Gloria Jones (gloriaj)
 Program ID: apwarrnt

City of Jackson



ACCOUNTS PAYABLE CHECK RUN REPORT
Detail Invoice List

CHECK RUN: CD052323 05/23/2023
 DUE DATE: 05/23/2023

CASH ACCOUNT: 999		1100		POOLED CASH - AP DISBURSEMENTS									
VENDOR	REMIT	PO	TYPE	DUE DATE	INVOICE	AMOUNT	DOCUMENT	VOUCHER	CHECK	LINE AMOUNT	LINE AMOUNT	LINE AMOUNT	LINE AMOUNT
14420	REVELL HARDWARE COMPA	0000	99230170	EFT	05/23/2023	1247837	91362			87.38	91363		
	ACCOUNT DETAIL												
	1 00145125 6316		SBD - D	MOTOR VEH						87.38			
14420	REVELL HARDWARE COMPA	0000	99230170	EFT	05/23/2023	1247827	91363			87.38			
	ACCOUNT DETAIL												
	1 00145125 6316		SBD - D	MOTOR VEH						57.93			
14420	REVELL HARDWARE COMPA	0000	99230170	EFT	05/23/2023	256425/1	91364			8.78			
	ACCOUNT DETAIL												
	1 00145124 6316		SBD - PAV	MOTOR VEH						8.78			
14420	REVELL HARDWARE COMPA	0000	99230170	EFT	05/23/2023	124778/7	91365			87.38			
	ACCOUNT DETAIL												
	1 00145125 6316		SBD - D	MOTOR VEH						87.38			
14420	REVELL HARDWARE COMPA	0000	99230170	EFT	05/23/2023	125196/7	91366			76.93			
	ACCOUNT DETAIL												
	1 00145125 6316		SBD - D	MOTOR VEH						76.93			
14420	REVELL HARDWARE COMPA	0000	99230170	EFT	05/23/2023	125193/7	91367			134.88			
	ACCOUNT DETAIL												
	1 00145125 6316		SBD - D	MOTOR VEH						134.88			
14420	REVELL HARDWARE COMPA	0000	99230170	EFT	05/23/2023	125194/7	91368			76.93			
	ACCOUNT DETAIL												
	1 00145125 6316		SBD - D	MOTOR VEH						76.93			
14420	REVELL HARDWARE COMPA	0000	99230170	EFT	05/23/2023	125195/7	91369			76.93			
	ACCOUNT DETAIL												
	1 00145125 6316		SBD - D	MOTOR VEH						76.93			
14420	REVELL HARDWARE COMPA	0000	99230170	EFT	05/23/2023	195186/3	91370			26.99			
	ACCOUNT DETAIL												
	1 00145125 6316		SBD - D	MOTOR VEH						26.99			

City of Jackson

ACCOUNTS PAYABLE CHECK RUN REPORT

Detail Invoice List

CHECK RUN: CD052323 05/23/2023
 DUE DATE: 05/23/2023



CASH ACCOUNT: 999		1100		POOLED CASH - AP DISBURSEMENTS				INVOICE	AMOUNT	DOCUMENT	VOUCHER	CHECK
VENDOR	REMIT	PO	TYPE	DUE DATE	INVOICE	AMOUNT	DOCUMENT	VOUCHER	CHECK			
14420	REVELL HARDWARE COMPA	0000	77230549	EFT	05/23/2023	25892271	91524					
ACCOUNT DETAIL						LINE AMOUNT						
1	00550126	6311	ATHLETICS BUILDING			6.98						
						CHECK TOTAL						
						1,370.04						
62567	RICHARDSON ATHLETICS	0000	23001171	INV	05/23/2023	40311	91590					
ACCOUNT DETAIL						LINE AMOUNT						
1	00550410	6211	PARKS - M AGRI + BO			2,415.00						
						CHECK TOTAL						
						2,415.00						
62567	RICHARDSON ATHLETICS	0000	23001160	INV	05/23/2023	40265	91591					
ACCOUNT DETAIL						LINE AMOUNT						
1	00550410	6211	PARKS - M AGRI + BO			2,338.00						
2	00550410	6422	PARKS - M FREIGHT E			397.41						
3	00550480	6230	PARKS - M HAND TOOL			159.96						
						CHECK TOTAL						
						2,895.37						
						5,310.37						
32031	RICOH USA INC	0000		EFT	05/23/2023	107192495	91815					
ACCOUNT DETAIL						LINE AMOUNT						
1	00140500	6514	OFFICE OF RENTAL OF			5,997.48						
						CHECK TOTAL						
						5,997.48						
30057	RICOH USA INC	0000		EFT	05/23/2023	5067257457	91816					
ACCOUNT DETAIL						LINE AMOUNT						
1	00140500	6514	OFFICE OF RENTAL OF			567.19						
						CHECK TOTAL						
						49.30						
						616.49						
30057	RICOH USA INC	0000		EFT	05/23/2023	1097008165	91824					
ACCOUNT DETAIL						LINE AMOUNT						
1	00140500	6514	OFFICE OF RENTAL OF			49.30						
						CHECK TOTAL						
						49.30						
						616.49						
63817	ROBERT J YOUNG COMPAN	0000		INV	05/23/2023	INV6310611	91823					
ACCOUNT DETAIL						LINE AMOUNT						
1	00145300	6514	CARE & MA RENTAL OF			159.39						
						CHECK TOTAL						
						159.39						

Report generated: 05/19/2023 10:26:37
 User: Gloria Jones (gloriaj)
 Program ID: apawarr

City of Jackson



ACCOUNTS PAYABLE CHECK RUN REPORT

Detail Invoice List

CHECK RUN: CD052323 05/23/2023
 DUE DATE: 05/23/2023

CASH ACCOUNT:	999	1100	POOLED CASH - AP DISBURSEMENTS			INVOICE	AMOUNT	DOCUMENT	VOUCHER	CHECK
VENPOR	REMIT	PO	TYPE	DUE DATE	CHECK TOTAL					
63817	ROBERT J YOUNG COMPAN	0000	INV	05/23/2023	INV6089911	91738				
	ACCOUNT DETAIL									
	1 00141510 6514		MCS ADMIN RENTAL OF		766.24					
					CHECK TOTAL		766.24			
63817	ROBERT J YOUNG COMPAN	0000	INV	05/23/2023	INV6246045	91740				
	ACCOUNT DETAIL									
	1 00141510 6514		MCS ADMIN RENTAL OF		141.83					
					CHECK TOTAL		141.83			
70417	RRW LLC DOOR & HARDWA	0000	INV	05/23/2023	9965	91198				
	ACCOUNT DETAIL									
	1 00550125 6419		PROGRAMMOTHER PRO		300.00					
	2 00550125 6461		PROGRAMMIBUILDINGS		1,297.00					
					CHECK TOTAL		1,597.00			
400523	RUTHIE WEBB	0000	INV	05/23/2023	001112753	91216				
	ACCOUNT DETAIL									
	1 00550126 6419		ATHLETICS OTHER PRO		33.00					
					CHECK TOTAL		33.00			
72857	SAFE AND SOUND SURVEI	0000	INV	05/23/2023	202267	90872				
	ACCOUNT DETAIL									
	1 18756510 6461		JATRAN-OP BUILDINGS		1,360.00					
					CHECK TOTAL		1,360.00			
72857	SAFE AND SOUND SURVEI	0000	INV	05/23/2023	202268	90875				
	ACCOUNT DETAIL									
	1 18756510 6461		JATRAN-OP BUILDINGS		3,020.00					
					CHECK TOTAL		4,380.00			

City of Jackson



ACCOUNTS PAYABLE CHECK RUN REPORT

Detail Invoice List

CHECK RUN: CD052323 05/23/2023
 DUE DATE: 05/23/2023

CASH ACCOUNT	999	1100	REMIT	PO	TYPE	DUE DATE	INVOICE	AMOUNT	DOCUMENT	VOUCHER	CHECK
VENDOR											
401242	SANDRA A HARPER		0000		INV	05/23/2023	001112748		91212		
	ACCOUNT DETAIL						LINE AMOUNT				
	1	00550126 6419					75.00				
							CHECK TOTAL	75.00			
401242	SANDRA A HARPER		0000		INV	05/23/2023	001112757		91502		
	ACCOUNT DETAIL						LINE AMOUNT				
	1	00550126 6419					75.00				
							CHECK TOTAL	150.00			
61991	SANSOM EQUIPMENT CO.,		0000		INV	05/23/2023	P03976		91550		
	ACCOUNT DETAIL						LINE AMOUNT				
	1	03152220 6465					1,894.60				
							CHECK TOTAL	1,894.60			
68346	SCOTT EQUIPMENT COMPA		0000		INV	05/23/2023	X18563		91686		
	ACCOUNT DETAIL						LINE AMOUNT				
	1	00950610 6316					2,117.20				
							CHECK TOTAL	2,117.20			
68346	SCOTT EQUIPMENT COMPA		0000		INV	05/23/2023	X16498		91687		
	ACCOUNT DETAIL						LINE AMOUNT				
	1	00950610 6316					639.89				
							CHECK TOTAL	639.89			
68812	SECRETARY OF STATE		0000		INV	05/23/2023	05112023		91814		
	ACCOUNT DETAIL						LINE AMOUNT				
	1	00141300 6443					25.00				
							CHECK TOTAL	25.00			
401917	SHANEKIA MOSLEY		0000		INV	05/23/2023	15		90862		
	ACCOUNT DETAIL						LINE AMOUNT				
	1	00141600 6218					86.40				
							CHECK TOTAL	86.40			

City of Jackson



ACCOUNTS PAYABLE CHECK RUN REPORT

Detail Invoice List

CHECK RUN: CD062323 05/23/2023
 DUE DATE: 05/23/2023

CASH ACCOUNT: 999		1100		POOLED CASH - AP DISBURSEMENTS						
VENDOR	REMIT	PO	TYPE	DUE DATE	INVOICE	AMOUNT	DOCUMENT	VOUCHER	CHECK	
15280	SHERWIN WILLIAMS #73	0000	77230535	INV	05/23/2023	1094-7				
	ACCOUNT DETAIL					LINE AMOUNT				
	1 00145300 6461		CARE & MA	BUILDINGS		59.80				
			CHECK TOTAL			59.80				
									91390	
42952	SMITH BODY SHOP	0000		INV	05/23/2023	11617				
	ACCOUNT DETAIL					LINE AMOUNT				
	1 00144220 6465		SUPPORT S	AUTO + TR		75.00				
			CHECK TOTAL			75.00				
									91877	
401670	SP METERS JACKSON MS	0000		INV	05/23/2023	1431				
	ACCOUNT DETAIL					LINE AMOUNT				
	1 37652010 6419		WATER	OTHER PROF		272,399.62				
			CHECK TOTAL			272,399.62				
									91199	
66485	STAFFERS INC	0000		EFT	05/23/2023	3026-05000966561				
	ACCOUNT DETAIL					LINE AMOUNT				
	1 00144420 6489		BUILDING	CONTRACT		448.50				
									91253	
66485	STAFFERS INC	0000		EFT	05/23/2023	3026-05000966895				
	ACCOUNT DETAIL					LINE AMOUNT				
	1 00144420 6489		BUILDING	CONTRACT		590.53				
									91293	
66485	STAFFERS INC	0000		EFT	05/23/2023	3026-05000966897				
	ACCOUNT DETAIL					LINE AMOUNT				
	1 00144420 6489		BUILDING	CONTRACT		239.20				
									91311	
66485	STAFFERS INC	0000		EFT	05/23/2023	3026-05000966956				
	ACCOUNT DETAIL					LINE AMOUNT				
	1 38271532 6419		SIG	OTHER PROF		994.00				
									91313	
66485	STAFFERS INC	0000		EFT	05/23/2023	3026-05000966956				
	ACCOUNT DETAIL					LINE AMOUNT				
	1 00144420 6489		BUILDING	CONTRACT		545.68				
									91690	
									545.68	

City of Jackson



ACCOUNTS PAYABLE CHECK RUN REPORT

Detail Invoice List

CHECK RUN: CD052323 05/23/2023
 DUE DATE: 05/23/2023

CASH ACCOUNT	999	1100	REMIT	PO	TYPE	DUE DATE	INVOICE	AMOUNT	DOCUMENT	VOUCHER	CHECK
VENDOR	66485	STAFFERS INC	0000		EFT	05/23/2023	3026-0500096958		91744		
ACCOUNT DETAIL		1 38271532 6419	SIG		OTHER PROF		1,126.00				
CHECK TOTAL							1,126.00				
CHECK TOTAL							3,943.91				
41230	STATE TREASURER	0000			INV	05/23/2023	04302023-1		91205		
ACCOUNT DETAIL		1 001 2368			GENERAL F ST ASSESS		426.84				
		2 .001 2384			GENERAL F COURT CON		190.14				
		3 001 2373			GENERAL F ST ASSESS		884.44				
		4 001 2372			GENERAL F ST ASSESS		4,103.52				
		5 001 2371			GENERAL F ST ASSESS		29,952.88				
		6 001 2377			GENERAL F MOTOR VEH		2,267.06				
		7 001 2380			GENERAL F ADULT DIRI		160.00				
		8 001 2362			GENERAL F ST ASSESS		2,606.88				
		9 001 2361			GENERAL F ST ASSESS		8.57				
		10 001 2354			GENERAL F STATE ASS		16.83				
		11 001 2355			GENERAL F ST ASSESS		5,832.47				
CHECK TOTAL							46,449.63				
CHECK TOTAL							46,449.63				
60405	STEW POT COMMUNITY SER	0000			EFT	05/23/2023	1009		91724		
ACCOUNT DETAIL		1 38271535 6742			STWPTCDCVCNTRB OTH		10,074.21				
CHECK TOTAL							10,074.21				
60405	STEW POT COMMUNITY SER	0000			EFT	05/23/2023	322		91725		
ACCOUNT DETAIL		1 38271535 6742			STWPTCDCVCNTRB OTH		20,163.68				
CHECK TOTAL							20,163.68				
60405	STEW POT COMMUNITY SER	0000			EFT	05/23/2023	20231		91726		
ACCOUNT DETAIL		1 08659510 6742			BILLY BRU CTOA		4,310.56				
CHECK TOTAL							4,310.56				
60405	STEW POT COMMUNITY SER	0000			EFT	05/23/2023	20232		91728		
ACCOUNT DETAIL		1 08659520 6742			MATT'S HO CTOA		937.52				
CHECK TOTAL							937.52				

Report generated: 05/18/2023 10:26:37
 User: Gloria Jones (glorhjl)
 Program ID: apwerrtl

City of Jackson



ACCOUNTS PAYABLE CHECK RUN REPORT

Detail Invoice List

CHECK RUN: CD052323 05/23/2023
 DUE DATE: 05/23/2023

CASH ACCOUNT: 999		1100		POOLED CASH - AP DISBURSEMENTS										
VENDOR	REMIT	PO	TYPE	DUE DATE	INVOICE	AMOUNT	DOCUMENT	VOUCHER	CHECK	LINE AMOUNT	LINE AMOUNT	LINE AMOUNT	LINE AMOUNT	LINE AMOUNT
60405	STEW POT COMMUNITY SER	0000	EFT	05/23/2023	100									
	ACCOUNT DETAIL													
	1 37971513 6742		STEW POT-ESNTRB OTH			3,487.28				3,487.28				
						CHECK TOTAL				38,973.25				
46223	STREET ENTERPRISES	0000	INV	05/23/2023	071889									
	ACCOUNT DETAIL													
	1 00144220 6465		SUPPORT S AUTO + TR			85.00				85.00				
46223	STREET ENTERPRISES	0000	INV	05/23/2023	071929									
	ACCOUNT DETAIL													
	1 00144220 6465		SUPPORT S AUTO + TR			100.00				100.00				
46223	STREET ENTERPRISES	0000	INV	05/23/2023	071977									
	ACCOUNT DETAIL													
	1 00144220 6465		SUPPORT S AUTO + TR			100.00				100.00				
46223	STREET ENTERPRISES	0000	INV	05/23/2023	071984									
	ACCOUNT DETAIL													
	1 00144220 6465		SUPPORT S AUTO + TR			100.00				100.00				
46223	STREET ENTERPRISES	0000	INV	05/23/2023	072278									
	ACCOUNT DETAIL													
	1 00144220 6465		SUPPORT S AUTO + TR			100.00				100.00				
46223	STREET ENTERPRISES	0000	INV	05/23/2023	072282									
	ACCOUNT DETAIL													
	1 00144220 6465		SUPPORT S AUTO + TR			100.00				100.00				
46223	STREET ENTERPRISES	0000	INV	05/23/2023	072283									
	ACCOUNT DETAIL													
	1 00144220 6465		SUPPORT S AUTO + TR			100.00				100.00				
46223	STREET ENTERPRISES	0000	INV	05/23/2023	02282022									
	ACCOUNT DETAIL													
	1 00144220 6465		SUPPORT S AUTO + TR			75.00				75.00				

Report generated: 05/18/2023 10:26:37
 User: Gloria Jones (gborjal)
 Program ID: apwarrmt

City of Jackson



ACCOUNTS PAYABLE CHECK RUN REPORT

Detail Invoice List

CHECK RUN: CD052323 05/23/2023
 DUE DATE: 05/23/2023

VENDOR	CASH ACCOUNT	999	1100	REMIT	PO	TYPE	DUE DATE	INVOICE	AMOUNT	DOCUMENT	VOUCHER	CHECK
16241	STRIBLING EQUIPMENT I	0000	99230224	INV			05/23/2023	CS001133063:01				
	ACCOUNT DETAIL							LINE AMOUNT				
	1 00550410 6464							782.76				
								CHECK TOTAL	782.76			
47085	STUART C IRBY CO	0000	77230533	INV			05/23/2023	S013531851:001				
	ACCOUNT DETAIL							LINE AMOUNT				
	1 00550140 6315							279.00				
								CHECK TOTAL	279.00			
47085	STUART C IRBY CO	0000	77230466	INV			05/23/2023	S013478896:001				
	ACCOUNT DETAIL							LINE AMOUNT				
	1 00550126 6315							754.07				
								CHECK TOTAL	754.07			
47085	STUART C IRBY CO	0000	77230547	INV			05/23/2023	S013530849:001				
	ACCOUNT DETAIL							LINE AMOUNT				
	1 00145300 6317							988.79				
								CHECK TOTAL	988.79			
47085	STUART C IRBY CO	0000	77230545	INV			05/23/2023	S013526906:001				
	ACCOUNT DETAIL							LINE AMOUNT				
	1 00145300 6461							490.64				
								CHECK TOTAL	490.64			
47085	STUART C IRBY CO	0000	77230545	INV			05/23/2023	S013526906:002				
	ACCOUNT DETAIL							LINE AMOUNT				
	1 00145300 6461							121.50				
								CHECK TOTAL	121.50			
40994	SUNBELT FIRE APPARATU	0000	88230167	EFT			05/23/2023	00001392				
	ACCOUNT DETAIL							LINE AMOUNT				
	1 00144120 6316							4,942.07				
								CHECK TOTAL	4,942.07			
40994	SUNBELT FIRE APPARATU	0000	88230192	EFT			05/23/2023	00001389				
	ACCOUNT DETAIL							LINE AMOUNT				
	1 00144120 6316							201.16				
								CHECK TOTAL	201.16			

Report generated: 05/18/2023 10:25:37
 User: Gloria Jones (glorj)
 Program ID: apwarrnt

City of Jackson



ACCOUNTS PAYABLE CHECK RUN REPORT

Detail Invoice List

CHECK RUN: CD052323 05/23/2023
 DUE DATE: 05/23/2023

CASH ACCOUNT	999	1100	POOLED CASH - AP DISBURSEMENTS				INVOICE	AMOUNT	DOCUMENT	VOUCHER	CHECK
VENDOR	REMIT	PO	TYPE	DUE DATE	INVOICE	LINE AMOUNT					
40994	SUNBELT FIRE APPARATU	0000	88230192	EFT	05/23/2023	00001673					
ACCOUNT DETAIL						LINE AMOUNT					
1	00144120	6316			EMERGENCMOTOR VEH	252.74	252.74	91675			
CHECK TOTAL							5,395.97				
401469	SUNRISE FRESH PRODUCE	0000	23001141	INV	05/23/2023	14-761871					
ACCOUNT DETAIL						LINE AMOUNT					
1	39049800	6214			ZOO PARK FEED FOR A	839.42					
2	39049800	6215			ZOO PARK FUEL USAGE	6.50	845.92	91223			
CHECK TOTAL							845.92				
401188	TERRI MELTON PALMER	0000		INV	05/23/2023	001112752					
ACCOUNT DETAIL						LINE AMOUNT					
1	00550126	6419			ATHLETICS OTHER PRO	33.00	33.00	91215			
401188	TERRI MELTON PALMER	0000		INV	05/23/2023	001112761					
ACCOUNT DETAIL						LINE AMOUNT					
1	00550126	6419			ATHLETICS OTHER PRO	33.00	33.00	91506			
CHECK TOTAL							66.00				
69926	GANNETT RIVER STATE P	0000		INV	05/23/2023	0004981324					
ACCOUNT DETAIL						LINE AMOUNT					
1	00141120	6444			BUDGET OF LEGAL ADS	781.50	781.50	91551			
CHECK TOTAL							781.50				
401642	THE EVANS AGENCY, INC	0000		INV	05/23/2023	293875					
ACCOUNT DETAIL						LINE AMOUNT					
1	00140792	6541			WORKERS CINSURANCE	140,734.00	140,734.00	91252			
CHECK TOTAL							140,734.00				
72057	THE SOUTHERN CONNECTI	0000	23000738	INV	05/23/2023	25686					
ACCOUNT DETAIL						LINE AMOUNT					
1	00144130	6217			OFFICE OF UNIFORMS	527.88	527.88	91555			

Report generated: 05/18/2023 10:26:37
 User: Gloria Jones (gloriaj)
 Program ID: spwerrn1

City of Jackson



ACCOUNTS PAYABLE CHECK RUN REPORT

Detail Invoice List

CHECK RUN: CD052323 05/23/2023
 DUE DATE: 05/23/2023

CASH ACCOUNT	999	1100	REMIT	PO	TYPE	DUE DATE	INVOICE	AMOUNT	DOCUMENT	VOUCHER	CHECK
POOLED CASH - AP DISBURSEMENTS											
VENDOR											
53785	THOMSON REUTERS		0000		INV	05/23/2023	848235414	527.88	91407		
ACCOUNT DETAIL							LINE AMOUNT	527.88			
1	00140700	6318	LEGAL	BOOKS & P			2,116.03	2,116.03			
							CHECK TOTAL	2,116.03			
							CHECK TOTAL	2,116.03			
19685	THYSSENKRUPP ELEVATOR		0000		INV	05/23/2023	3007242374	91523			
ACCOUNT DETAIL							LINE AMOUNT				
1	00141810	6464	ARTS CENT	MACHINE/E			296.54				
2	00141910	6464	MUNICIPAL	MACHINE/E			1,317.07				
3	00142300	6419	REDEVELOP	OTHER PRO			148.27				
4	00144170	6419	FIRE STAT	OTHER PRO			153.93				
5	00144235	6317	PUBLIC SA	OTHER REP			1,174.47				
6	00145300	6464	CARE & MA	MACHINE/E			1,522.33				
							CHECK TOTAL	4,612.61			
							CHECK TOTAL	4,612.61			
401298	TOSHIBA AMERICA BUSIN		0000		INV	05/23/2023	5505765A	90870			
ACCOUNT DETAIL							LINE AMOUNT				
1	18756520	6514	TRANSIT S	RENTAL OF			604.84	604.84			
							CHECK TOTAL	604.84			
							CHECK TOTAL	604.84			
73259	TOWNSEND KILPATRICK		0000		INV	05/23/2023	12796768	91429			
ACCOUNT DETAIL							LINE AMOUNT				
1	00140700	6414	LEGAL	SPECIAL L			7,928.50	7,928.50			
							CHECK TOTAL	7,928.50			
							CHECK TOTAL	7,928.50			
73259	TOWNSEND KILPATRICK		0000		INV	05/23/2023	1279257	91509			
ACCOUNT DETAIL							LINE AMOUNT				
1	00140700	6414	LEGAL	SPECIAL L			4,191.50	4,191.50			
							CHECK TOTAL	4,191.50			
							CHECK TOTAL	12,120.00			

City of Jackson



ACCOUNTS PAYABLE CHECK RUN REPORT

Detail Invoice List

CHECK RUN: CD052323 05/23/2023
 DUE DATE: 05/23/2023

CASH ACCOUNT	999	1100	POOLED CASH - AP DISBURSEMENTS			INVOICE	AMOUNT	DOCUMENT	VOUCHER	CHECK
VENDOR	REMIT	PO	TYPE	DUE DATE	2023-4B					
71848	TRANSDEV SERVICES	0000	EFT	05/23/2023	282,391.49	282,391.49	91529			
	ACCOUNT DETAIL				LINE AMOUNT					
	1 18756510 6425		JATRAN-OP PUBLIC TR		282,391.49					
					CHECK TOTAL	282,391.49				
401491	TRANSUNION RISK AND A	0000	INV	05/23/2023	6179440-202304-1		90850			
	ACCOUNT DETAIL				LINE AMOUNT					
	1 00144470 6242		COMMUNITYDATA PROCE		110.00					
					CHECK TOTAL	110.00				
41410	TRUSTMARK NATIONAL BA	0000	INV	05/23/2023	04192023		91528			
	ACCOUNT DETAIL				LINE AMOUNT					
	1 39251107 6612		2019 7M INTEREST O		113,750.00					
					CHECK TOTAL	113,750.00				
17423	U S CONFERENCE OF MAY	0000	INV	05/23/2023	INV/003569		91834			
	ACCOUNT DETAIL				LINE AMOUNT					
	1 00149300 6443		MISC. ADM DUES, MEM.		9,181.00					
					CHECK TOTAL	9,181.00				
71850	UNITED HEALTHCARE INS	0000	EFT	05/23/2023	749841815274		91300			
	ACCOUNT DETAIL				LINE AMOUNT					
	1 05755820 6419		MEDICAL B OTHER PRO		47,000.04					
					CHECK TOTAL	47,000.04				
69412	UNITED PLUMBING & HEA	0000	INV	05/23/2023	1011938-1		91194			
	ACCOUNT DETAIL				LINE AMOUNT					
	1 40450133 6419		DFA-PETERROTHER PROF		3,550.00					
					CHECK TOTAL	3,550.00				
69412	UNITED PLUMBING & HEA	0000	INV	05/23/2023	1012401-1		91275			
	ACCOUNT DETAIL				LINE AMOUNT					
	1 00550140 6419		TENNIS CO OTHER PRO		432.00					
					CHECK TOTAL	432.00				

Report generated: 05/18/2023 10:28:37
 User: Gloria Jones (glorlaj)
 Program ID: apwarml

ACCOUNTS PAYABLE CHECK RUN REPORT

Detail Invoice List

CHECK RUN: CJD052323 05/23/2023
 DUE DATE: 05/23/2023

CASH ACCOUNT	999	1100	REMIT	PO	TYPE	DUE DATE	INVOICE	AMOUNT	DOCUMENT	VOUCHER	CHECK
69412	UNITE PLUMBING & HEA	0000	77230530	INV	05/23/2023	1012469-1	258.00	91282			
	ACCOUNT DETAIL										
	1 00141910 6317			MUNICIPAL OTHER REP			258.00				
69412	UNITE PLUMBING & HEA	0000	77230522	INV	05/23/2023	1012470-1	108.00	91283			
	ACCOUNT DETAIL										
	1 00141910 6317			MUNICIPAL OTHER REP			108.00				
69412	UNITE PLUMBING & HEA	0000	77230539	INV	05/23/2023	1012485-1	494.95	91286			
	ACCOUNT DETAIL										
	1 00145300 6461			CARE & MA BUILDINGS			494.95				
69412	UNITE PLUMBING & HEA	0000	77230541	INV	05/23/2023	1012481-1	1,202.00	91391			
	ACCOUNT DETAIL										
	1 00145124 6419			SBD - PAV OTHER PRO			300.50				
	2 00145125 6419			SBD - D OTHER PRO			300.50				
	3 03152210 6299			ADMINISTR OTHER OPE			23.25				
	4 03152215 6299			MAINTENAN OTHER OPE			277.25				
	5 03152220 6419			OPERATION OTHER PRO			300.50				
	CHECK TOTAL						248.00				
70140	UNIVERSAL SERVICES	0000	77230524	INV	05/23/2023	26790	4,550.00	91270			
	ACCOUNT DETAIL										
	1 00145300 6461			CARE & MA BUILDINGS			4,550.00				
70140	UNIVERSAL SERVICES	0000	77230515	INV	05/23/2023	26801	635.00	91356			
	ACCOUNT DETAIL										
	1 00144170 6461			FIRE STAT BUILDINGS			635.00				
	CHECK TOTAL						5,185.00				

City of Jackson



ACCOUNTS PAYABLE CHECK RUN REPORT

Detail Invoice List

CHECK RUN: CD062323 05/23/2023
 DUE DATE: 05/23/2023

CASH ACCOUNT: 999		1100		POOLED CASH - AP DISBURSEMENTS										
VENDOR	REMIT	PO	TYPE	DUE DATE	INVOICE	AMOUNT	DOCUMENT	VOUCHER	CHECK	LINE AMOUNT	LINE AMOUNT	LINE AMOUNT	LINE AMOUNT	LINE AMOUNT
70013	US BANCORP		INV	05/23/2023	062023P		92155							
	ACCOUNT DETAIL													
	1 00145300 6922		CARE & MA LEASE-ENE			186,946.54								
70013	US BANCORP		INV	05/23/2023	062023I		92156							
	ACCOUNT DETAIL													
	1 00145300 6612		CARE & MA INTEREST			14,808.33								
						201,754.87								
401243	V L GRAY		INV	05/23/2023	001112747		91211							
	ACCOUNT DETAIL													
	1 00550126 6419		ATHLETICS OTHER PRO			75.00								
						75.00								
						150.00								
71931	VOLKERT INC		INV	05/23/2023	01304016		91546							
	ACCOUNT DETAIL													
	1 17345190 6823		1% ENG CAPIOTBE			4,830.17								
						4,830.17								
71931	VOLKERT INC		INV	05/23/2023	01104017		91559							
	ACCOUNT DETAIL													
	1 17345190 6823		1% ENG CAPIOTBE			27,732.31								
						27,732.31								
						32,562.48								
43122	WASTE MANAGEMENT OF M		INV	05/23/2023	0004482-0148-3		91696							
	ACCOUNT DETAIL													
	1 00945510 6426		ADMINISTR TIPING F			13,497.71								
						13,497.71								
43122	WASTE MANAGEMENT OF M		INV	05/23/2023	0004481-0148-5		91699							
	ACCOUNT DETAIL													
	1 00945510 6426		ADMINISTR TIPING F			79,999.22								
						79,999.22								

Report generated: 05/18/2023 10:26:37
 User: Gloria Jones (gloriaj)
 Program ID: apwarrml

City of Jackson



ACCOUNTS PAYABLE CHECK RUN REPORT

Detail Invoice List

CHECK RUN: CD052323 05/23/2023
 DUE DATE: 05/23/2023

CASH ACCOUNT	999	1100	REMIT	PO	TYPE	DUE DATE	INVOICE	AMOUNT	DOCUMENT	VOUCHER	CHECK
18124	WATER SEWER BUSINESS	0000			INV	05/23/2023	022330052323	92069			
	ACCOUNT DETAIL						LINE AMOUNT				
	1 00144170 6452		FIRE STAT	WATER/SEWE			114.37				
								114.37	92070		
18124	WATER SEWER BUSINESS	0000			INV	05/23/2023	025530052323				
	ACCOUNT DETAIL						LINE AMOUNT				
	1 00144220 6452		SUPPORT S	WATER/SEWE			53.25				
								53.25	92071		
18124	WATER SEWER BUSINESS	0000			INV	05/23/2023	026530052323				
	ACCOUNT DETAIL						LINE AMOUNT				
	1 00141810 6452		ARTS CENT	WATER/SEWE			221.97				
								221.97	92072		
18124	WATER SEWER BUSINESS	0000			INV	05/23/2023	031620052323				
	ACCOUNT DETAIL						LINE AMOUNT				
	1 00144170 6452		FIRE STAT	WATER/SEWE			154.21				
								154.21	92074		
18124	WATER SEWER BUSINESS	0000			INV	05/23/2023	056920052323				
	ACCOUNT DETAIL						LINE AMOUNT				
	1 00144170 6452		FIRE STAT	WATER/SEWE			148.38				
								148.38	92075		
18124	WATER SEWER BUSINESS	0000			INV	05/23/2023	094630052323				
	ACCOUNT DETAIL						LINE AMOUNT				
	1 00144170 6452		FIRE STAT	WATER/SEWE			73.97				
								73.97	92077		
18124	WATER SEWER BUSINESS	0000			INV	05/23/2023	135530052323				
	ACCOUNT DETAIL						LINE AMOUNT				
	1 00145300 6452		CARE & MA	WATER/SEWE			1,232.60				
								1,232.60	92078		
18124	WATER SEWER BUSINESS	0000			INV	05/23/2023	159720052323				
	ACCOUNT DETAIL						LINE AMOUNT				
	1 00143300 6452		SPECIAL P	WATER/SEWE			1,002.49				
								1,002.49	92080		
18124	WATER SEWER BUSINESS	0000			INV	05/23/2023	162630052323				
	ACCOUNT DETAIL						LINE AMOUNT				
	1 00144220 6452		SUPPORT S	WATER/SEWE			44.45				
								44.45			

City of Jackson



ACCOUNTS PAYABLE CHECK RUN REPORT

Detail Invoice List

CHECK RUN: CD052323 05/23/2023
 DUE DATE: 05/23/2023

CASH ACCOUNT: 999		1100		POOLED CASH - AP DISBURSEMENTS											
VENDOR	REMIT	PO	TYPE	DUE DATE	INVOICE	AMOUNT	DOCUMENT	VOUCHER	CHECK	INVOICE	LINE AMOUNT	AMOUNT	DOCUMENT	VOUCHER	CHECK
18124	WATER SEWER BUSINESS	0000	INV	05/23/2023	186430052323		92081								
	ACCOUNT DETAIL				LINE AMOUNT	127.10						127.10	92082		
	1 00144220 6452		SUPPORT S WATER/SEWE												
18124	WATER SEWER BUSINESS	0000	INV	05/23/2023	231620052323		92082								
	ACCOUNT DETAIL				LINE AMOUNT	138.34						138.34	92084		
	1 00550460 6452		PARKS - BA WATER/SEWE												
18124	WATER SEWER BUSINESS	0000	INV	05/23/2023	235530052323		92084								
	ACCOUNT DETAIL				LINE AMOUNT	361.33						361.33	92085		
	1 00144170 6452		FIRE STAT WATER/SEWE												
18124	WATER SEWER BUSINESS	0000	INV	05/23/2023	242540052323		92085								
	ACCOUNT DETAIL				LINE AMOUNT	224.66						224.66	92088		
	1 00550125 6452		PROGRAMM WATER/SEWE												
18124	WATER SEWER BUSINESS	0000	INV	05/23/2023	299830052323		92088								
	ACCOUNT DETAIL				LINE AMOUNT	121.17						121.17	92090		
	1 00144170 6452		FIRE STAT WATER/SEWE												
18124	WATER SEWER BUSINESS	0000	INV	05/23/2023	332910052323		92090								
	ACCOUNT DETAIL				LINE AMOUNT	125.16						125.16	92093		
	1 00550480 6452		PARKS - M WATER/SEWE												
18124	WATER SEWER BUSINESS	0000	INV	05/23/2023	437330052323		92093								
	ACCOUNT DETAIL				LINE AMOUNT	280.88						280.88	92094		
	1 00144310 6452		TELECOMM WATER/SEWE												
18124	WATER SEWER BUSINESS	0000	INV	05/23/2023	439430052323		92094								
	ACCOUNT DETAIL				LINE AMOUNT	64.05						64.05	92096		
	1 00550125 6452		PROGRAMM WATER/SEWE												
18124	WATER SEWER BUSINESS	0000	INV	05/23/2023	445420052323		92096								
	ACCOUNT DETAIL				LINE AMOUNT	537.57						537.57			
	1 00550125 6452		PROGRAMM WATER/SEWE												

City of Jackson



ACCOUNTS PAYABLE CHECK RUN REPORT

Detail Invoice List

CHECK RUN: CD052323 05/23/2023
 DUE DATE: 05/23/2023

CASH ACCOUNT: 999 1100		POOLED CASH - AP DISBURSEMENTS									
VENDOR	REMIT	PO	TYPE	DUE DATE	INVOICE	AMOUNT	DOCUMENT	VOUCHER	CHECK		
18124	WATER SEWER BUSINESS	0000	INV	05/23/2023	501530052323		92099				
	ACCOUNT DETAIL				LINE AMOUNT						
	1 00140700 6452		LEGAL		155.07						
18124	WATER SEWER BUSINESS	0000	INV	05/23/2023	515000052323		92100				
	ACCOUNT DETAIL				LINE AMOUNT						
	1 00149100 6452		MUNICIPAL		440.05						
18124	WATER SEWER BUSINESS	0000	INV	05/23/2023	537530052323		92102				
	ACCOUNT DETAIL				LINE AMOUNT						
	1 00144226 6452		STANDARD		35.91						
18124	WATER SEWER BUSINESS	0000	INV	05/23/2023	550910052323		92103				
	ACCOUNT DETAIL				LINE AMOUNT						
	1 00144170 6452		FIRE STAT		190.75						
18124	WATER SEWER BUSINESS	0000	INV	05/23/2023	658510052323		92106				
	ACCOUNT DETAIL				LINE AMOUNT						
	1 00550453 6452		CEMETIERE		52.93						
18124	WATER SEWER BUSINESS	0000	INV	05/23/2023	671350052323		92108				
	ACCOUNT DETAIL				LINE AMOUNT						
	1 00144170 6452		FIRE STAT		701.88						
18124	WATER SEWER BUSINESS	0000	INV	05/23/2023	680230052323		92109				
	ACCOUNT DETAIL				LINE AMOUNT						
	1 00144170 6452		FIRE STAT		290.03						
18124	WATER SEWER BUSINESS	0000	INV	05/23/2023	762530052323		92110				
	ACCOUNT DETAIL				LINE AMOUNT						
	1 00145124 6452		SBD - PAV		80.94						
18124	WATER SEWER BUSINESS	0000	INV	05/23/2023	764630052323		92111				
	ACCOUNT DETAIL				LINE AMOUNT						
	1 00550180 6452		AQUATICS		302.51						

Report generated: 05/18/2023 10:26:37
 User: Gloria Jones (glorja)
 Program ID: apwarml

City of Jackson



ACCOUNTS PAYABLE CHECK RUN REPORT

Detail Invoice List

CHECK RUN: CD052323 05/23/2023
 DUE DATE: 05/23/2023

CASH ACCOUNT: 999		1100		POOLED CASH - AP DISBURSEMENTS						
VENDOR		REMIT	PO	TYPE	DUE DATE	INVOICE	AMOUNT	DOCUMENT	VOUCHER	CHECK
18124	WATER SEWER BUSINESS	0000		INV	05/23/2023	772530052323		92112		
	ACCOUNT DETAIL					LINE AMOUNT				
	1 00141910 6452			ARTS CENT WATER/SEWE		167.67	167.67			
18124	WATER SEWER BUSINESS	0000		INV	05/23/2023	778530052323		92113		
	ACCOUNT DETAIL					LINE AMOUNT				
	1 00144170 6452			FIRE STAT WATER/SEWE		128.56	128.56			
18124	WATER SEWER BUSINESS	0000		INV	05/23/2023	816350052323		92114		
	ACCOUNT DETAIL					LINE AMOUNT				
	1 00144170 6452			FIRE STAT WATER/SEWE		1,125.90	1,125.90			
18124	WATER SEWER BUSINESS	0000		INV	05/23/2023	818710052323		92115		
	ACCOUNT DETAIL					LINE AMOUNT				
	1 00143300 6452			SPECIAL P WATER/SEWE		126.92	126.92			
18124	WATER SEWER BUSINESS	0000		INV	05/23/2023	836040052323		92116		
	ACCOUNT DETAIL					LINE AMOUNT				
	1 00144170 6452			FIRE STAT WATER/SEWE		27.61	27.61			
18124	WATER SEWER BUSINESS	0000		INV	05/23/2023	856330052323		92117		
	ACCOUNT DETAIL					LINE AMOUNT				
	1 00560125 6452			PROGRAMM WATER/SEWE		47.94	47.94			
18124	WATER SEWER BUSINESS	0000		INV	05/23/2023	861910052323		92118		
	ACCOUNT DETAIL					LINE AMOUNT				
	1 00550480 6452			PARKS - M WATER/SEWE		125.16	125.16			
18124	WATER SEWER BUSINESS	0000		INV	05/23/2023	888530052323		92121		
	ACCOUNT DETAIL					LINE AMOUNT				
	1 00144170 6452			FIRE STAT WATER/SEWE		64.46	64.46			
18124	WATER SEWER BUSINESS	0000		INV	05/23/2023	925530052323		92123		
	ACCOUNT DETAIL					LINE AMOUNT				
	1 00141910 6452			MUNICIPAL WATER/SEWE		367.89	367.89			

Report generated: 05/18/2023 10:26:37
 User: Gloria Jones (glojaj)
 Program ID: apwarrnt



City of Jackson

ACCOUNTS PAYABLE CHECK RUN REPORT

Detail Invoice List

CHECK RUN: CD062323 05/23/2023
 DUE DATE: 05/23/2023

CASH ACCOUNT	999	1100	POOLED CASH - AP DISBURSEMENTS				INVOICE	AMOUNT	DOCUMENT	VOUCHER	CHECK
VENDOR	18124	WATER SEWER BUSINESS	REMIT	PO	TYPE	DUE DATE	962530052323				
ACCOUNT DETAIL											
	1	00145610 6452			VEHICLE M WATERSEWE		315.44				
CHECK TOTAL							315.44				
CHECK TOTAL							9,773.57				
ACCOUNT DETAIL											
59395		WESTMORELAND PEARLIE	0000		EFT	05/23/2023	04132023			91206	
ACCOUNT DETAIL											
	1	00140794 6419			CLAIMS (O OTHER PRO		108.00				
CHECK TOTAL							108.00				
CHECK TOTAL							108.00				
62269		WICS, INC.	0000	23001208	INV	05/23/2023	04142023			91262	
ACCOUNT DETAIL											
	1	00144820 6317			TRAFFIC S OTHER REP		243.40				
	2	00144820 6419			TRAFFIC S OTHER PRO		180.00				
CHECK TOTAL							423.40				
CHECK TOTAL							423.40				
401247		WILSON T BLACKMON	0000		INV	05/23/2023	001112754			91508	
ACCOUNT DETAIL											
	1	00550126 6419			ATHLETICS OTHER PRO		75.00				
CHECK TOTAL							75.00				
CHECK TOTAL							75.00				
71264		YAMAHA MOTOR CORPORAT	0000		EFT	05/23/2023	803514			90865	
ACCOUNT DETAIL											
	1	00550430 6514			PARKS-GO RENTAL OF		7,980.74				
CHECK TOTAL							7,980.74				
CHECK TOTAL							7,980.74				
WARRANT TOTAL							3,379,126.59				
WARRANT TOTAL							3,379,126.59				

Report generated: 05/18/2023 10:26:37
 User: Glorie Jones (gloriej)
 Program ID: apwarrml

City of Jackson



ACCOUNTS PAYABLE CHECK RUN REPORT

Check Run Summary

CHECK RUN: CD052323 05/23/2023
 DUE DATE: 05/23/2023

FUND	ORG	ACCOUNT	AMOUNT	AVL/B BUDGET
0001	001	GENERAL FUND	16.83	
0001	001	GENERAL FUND	5,832.47	
0001	001	GENERAL FUND	8.57	
0001	001	GENERAL FUND	2,606.88	
0001	001	GENERAL FUND	426.84	
0001	001	GENERAL FUND	29,952.88	
0001	001	GENERAL FUND	4,103.52	
0001	001	GENERAL FUND	884.44	
0001	001	GENERAL FUND	2,267.06	
0001	001	GENERAL FUND	3,400.00	
0001	001	GENERAL FUND	160.00	
0001	001	GENERAL FUND	190.14	
0001	001	GENERAL FUND	90,024.78	
0001	001	GENERAL FUND	114.90	
0001	001	GENERAL FUND	32.00	0.00
0001	001	GENERAL FUND	286.39	1,111.48
0001	001	GENERAL FUND	1,150.12	929.50
0001	001	GENERAL FUND	234.79	3,353.47
0001	001	GENERAL FUND	555.00	1,711.77
0001	001	GENERAL FUND	1,763.68	648.78
0001	001	GENERAL FUND	721.52	70.66
0001	001	GENERAL FUND	274.20	223.09
0001	001	GENERAL FUND	76.64	18.98
0001	001	GENERAL FUND	960.00	0.00
0001	001	GENERAL FUND	516.00	27.00
0001	001	GENERAL FUND	83.85	2,137.00
0001	001	GENERAL FUND	377.63	0.00
0001	001	GENERAL FUND	6,613.97	6,658.77
0001	001	GENERAL FUND	2,116.03	-4,959.53
0001	001	GENERAL FUND	12,378.45	28,562.50
0001	001	GENERAL FUND	1,766.16	248.80
0001	001	GENERAL FUND	155.07	-2,282.07
0001	001	GENERAL FUND	389.80	800.00
0001	001	GENERAL FUND	229.00	667.17
0001	001	GENERAL FUND	75.00	158.00
0001	001	GENERAL FUND	15,000.00	0.00
0001	001	GENERAL FUND	336.13	2,026.08
0001	001	GENERAL FUND	140,734.00	455,127.45
0001	001	GENERAL FUND	1,695.54	76,197.49
0001	001	GENERAL FUND	238.00	36,533.47

City of Jackson



ACCOUNTS PAYABLE CHECK RUN REPORT

Account Number	Description	Amount	Balance
0001 00141110	OFFICE OF THE CONTROL	495.00	306.58
0001 00141110	OFFICE OF THE CONTROL	111.69	779.94
0001 00141120	BUDGET OFFICE	781.50	17,375.78
0001 00141130	OFFICE OF THE TREASUR	93.85	2,367.27
0001 00141300	PERSONNEL & CIVIL SER	383.85	2,391.29
0001 00141300	PERSONNEL & CIVIL SER	1,050.00	443.00
0001 00141300	PERSONNEL & CIVIL SER	650.90	3,730.19
0001 00141300	PERSONNEL & CIVIL SER	3,477.24	20,029.12
0001 00141300	PERSONNEL & CIVIL SER	1,108.60	25,064.82
0001 00141510	MCS ADMIN	908.07	4,466.31
0001 00141510	MCS ADMIN	85.40	808.51
0001 00141600	CITY COUNCIL	7,323.32	175.84
0001 00141600	CITY COUNCIL	389.54	3,813.87
0001 00141810	ARTS CENTER	296.54	87.00
0001 00141810	ARTS CENTER	1,237.05	666.15
0001 00141910	MUNICIPAL AUDITORIUM	367.89	2,912.66
0001 00141910	MUNICIPAL AUDITORIUM	1,407.07	242.28
0001 00142300	REDEVELOPMENT AUTHORI	148.27	2,582.58
0001 00142610	OFFICE OF ECON DEVA	370.00	40.00
0001 00142630	BUSINESS DEVELOPMENT	231.40	136.94
0001 00142800	MUNICIPAL CLERK	377.63	-113.78
0001 00142800	MUNICIPAL CLERK	35.58	659.32
0001 00143300	SPECIAL PROGRAMS-ADMI	486.36	4,642.64
0001 00143300	SPECIAL PROGRAMS-ADMI	1,129.41	761.25
0001 00143300	SPECIAL PROGRAMS-ADMI	4,617.50	1,659.00
0001 00143300	SPECIAL PROGRAMS-ADMI	1,372.25	2,087.97
0001 00143420	AGING PROGRAM OPERATI	7,204.33	2,021.01
0001 00144120	EMERGENCY SERVICES DI	30.00	4,354.61
0001 00144120	EMERGENCY SERVICES DI	3,776.00	5,686.84
0001 00144120	EMERGENCY SERVICES DI	11,605.35	6,188.32
0001 00144130	EMERGENCY SERVICES DI	12.55	153.64
0001 00144140	HUMAN RESOURCES DIVI	527.88	54.75
0001 00144140	HUMAN RESOURCES DIVI	800.00	10.00
0001 00144160	FIRE VEHICLE REPAIR(U	443.60	1,658.90
0001 00144170	FIRE STATIONS & BLDGS	339.98	-48.00
0001 00144170	FIRE STATIONS & BLDGS	1,556.98	1,767.75
0001 00144170	FIRE STATIONS & BLDGS	10,325.69	16,187.02
0001 00144170	FIRE STATIONS & BLDGS	3,502.62	11,583.78
0001 00144210	OFFICE OF THE CHIEF	4,900.43	4,297.73
0001 00144210	OFFICE OF THE CHIEF	10,832.90	0.00
0001 00144220	SUPPORT SERVICES	950.00	950.00
0001 00144220	SUPPORT SERVICES	1,174.12	4,572.69
0001 00144220	SUPPORT SERVICES	13,975.55	13,163.91
0001 00144220	SUPPORT SERVICES	224.80	25,630.31
0001 00144220	SUPPORT SERVICES	4.24	26,630.02

Report generated: 05/18/2023 10:26:37
 User: Gloria Jones (gloriaj)
 Program ID: apwarrr1

ACCOUNTS PAYABLE CHECK RUN REPORT

Account Number	Description	Account	Amount	Description	Amount	Amount
0001	SUPPORT SERVICES	0001-0400-442-44220-01-100-04-000-6465	2,525.00	AUTO + TRUCK GARAGE +	7,428.93	
0001	ADMINISTRATIVE SERVIC	0001-0400-442-44224-01-100-04-000-6461	540.00	BUILDINGS MAINTENANCE	0.00	
0001	ADMINISTRATIVE SERVIC	0001-0400-442-44224-01-100-04-000-6514	6,730.41	RENTAL OF EQUIPMENT	17,676.61	
0001	CRIME LAB	0001-0400-442-44225-01-100-04-000-6419	1,114.18	OTHER PROFESSIONAL SE	6,655.88	
0001	CRIME LAB	0001-0400-442-44225-01-100-04-000-6451	1,113.97	ELECTRIC LIGHT AND PO	4,138.88	
0001	STANDARDS AND TRAININ	0001-0400-442-44226-01-100-04-000-6419	8,282.00	OTHER PROFESSIONAL SE	29,395.58	
0001	STANDARDS AND TRAININ	0001-0400-442-44226-01-100-04-000-6452	35.91	WATERSEWER - UTILITY	1,945.34	
0001	PUBLIC SAFETY COMMUNI	0001-0400-442-44235-01-100-04-000-6317	1,174.47	OTHER REPAIR & MAINT	22,166.67	
0001	PUBLIC SAFETY COMMUNI	0001-0400-442-44235-01-100-04-000-6454	65.51	TELEPHONE	4,636.11	
0001	OPERATIONS	0001-0400-442-44240-01-100-04-000-6316	44,033.40	MOTOR VEHICLE REPAIR	2,585.04	
0001	OPERATIONS	0001-0400-442-44240-01-100-04-000-6419	5,000.00	OTHER PROFESSIONAL SE	5,405.01	
0001	OPERATIONS	0001-0400-442-44240-01-100-04-000-6422	30.00	FREIGHT EXPRESS & TRU	328.88	
0001	OPERATIONS	0001-0400-442-44240-01-100-04-000-6451	1,490.44	ELECTRIC LIGHT AND PO	948.15	
0001	PRECINCT ONE	0001-0400-442-44241-01-100-04-000-6451	47.79	ELECTRIC LIGHT AND PO	2,576.65	
0001	PRECINCT TWO	0001-0400-442-44242-01-100-04-000-6612	673.06	INTEREST ON DEBT	1,024.29	
0001	PRECINCT TWO	0001-0400-442-44242-01-100-04-000-6923	3,533.56	LEASE PURCHASE BUILDI	991.25	
0001	PRECINCT FOUR	0001-0400-442-44244-01-100-04-000-6451	82.26	ELECTRIC LIGHT AND PO	4,248.94	
0001	TELECOMMUNICATIONS	0001-1200-443-44310-01-100-01-000-6316	55.16	MOTOR VEHICLE REPAIR	900.44	
0001	TELECOMMUNICATIONS	0001-1200-443-44310-01-100-01-000-6451	4,171.99	ELECTRIC LIGHT AND PO	2,309.44	
0001	TELECOMMUNICATIONS	0001-1200-443-44310-01-100-01-000-6452	280.88	WATERSEWER - UTILITY	1,928.44	
0001	TELECOMMUNICATIONS	0001-1200-443-44310-01-100-01-000-6454	360.94	TELEPHONE	675.25	
0001	ADMINISTRATION	0001-0700-444-44410-01-100-01-000-6455	823.92	CELLULAR PHONES	259.28	
0001	BUILDING & PERMIT ADM	0001-0700-444-44420-01-100-01-000-6218	274.20	OFFICE SUPPLIES	501.76	
0001	BUILDING & PERMIT ADM	0001-0700-444-44420-01-100-01-000-6422	30.00	BOOKS & PERIODICALS/IN	659.50	
0001	BUILDING & PERMIT ADM	0001-0700-444-44420-01-100-01-000-6489	30.00	FREIGHT EXPRESS & TRU	0.00	
0001	COMMUNITY IMPROVEMENT	0001-0700-444-44470-01-100-01-000-6242	1,823.91	CONTRACT LABOR	-2,519.44	
0001	COMMUNITY IMPROVEMENT	0001-0700-444-44470-01-100-01-000-6246	247.60	DATA PROCESSING EQUIP	2,360.06	
0001	COMMUNITY IMPROVEMENT	0001-0700-444-44470-01-100-01-000-6446	110.00	CONTRACT DEMOLITION S	5,100.00	
0001	COMMUNITY IMPROVEMENT	0001-0700-444-44470-01-100-01-000-6455	642.00	CELLULAR PHONES	102,968.56	
0001	COMMUNITY IMPROVEMENT	0001-0700-444-44470-01-100-01-000-6473	479.72	TRAVEL EXPENSE - OUT	0.56	
0001	TRAFFIC ADMINISTRATIV	0001-0500-448-44810-01-100-05-000-6299	1,162.30	RENTAL OF EQUIPMENT	1,068.36	
0001	TRAFFIC ADMINISTRATIV	0001-0500-448-44820-01-100-05-000-6516	492.30	OTHER OPERATING SUPPL	259.96	
0001	TRAFFIC SIGNALS SECTI	0001-0500-448-44820-01-100-05-000-6299	123.32	UNIFORMS RUGS ETC. RE	1,523.84	
0001	TRAFFIC SIGNALS SECTI	0001-0500-448-44820-01-100-05-000-6317	243.40	OTHER OPERATING SUPPL	54.24	
0001	TRAFFIC SIGNALS SECTI	0001-0500-448-44820-01-100-05-000-6419	935.66	OTHER REPAIR & MAINT	1,503.63	
0001	TRAFFIC SIGNALS SECTI	0001-0500-448-44820-01-100-05-000-6451	180.00	OTHER PROFESSIONAL SE	188.50	
0001	PUBLIC WORK - ENGINEE	0001-0500-450-45010-01-100-05-000-6443	118.51	ELECTRIC LIGHT AND PO	22,338.20	
0001	PUBLIC WORK - ENGINEE	0001-0500-450-45010-01-100-05-000-6514	824.00	DUES MEM. REGIS FEES	61.83	
0001	STREETS/BRIDGES/DRAIN	0001-0500-451-45110-01-100-05-000-6218	458.33	RENTAL OF EQUIPMENT	222.56	
0001	STREETS/BRIDGES/DRAIN	0001-0500-451-45110-01-100-05-000-6514	105.63	OFFICE SUPPLIES	896.27	
0001	SBD - PAVED STREETS	0001-0500-451-45124-01-100-05-000-6316	137.21	RENTAL OF EQUIPMENT	2,282.14	
0001	SBD - PAVED STREETS	0001-0500-451-45124-01-100-05-000-6320	13,319.26	MOTOR VEHICLE REPAIR	15,719.76	
0001	SBD - PAVED STREETS	0001-0500-451-45124-01-100-05-000-6320	702.15	ASPHALT-ROUTINE MAINT	23,380.81	
0001	SBD - PAVED STREETS	0001-0500-451-45124-01-100-05-000-6419	300.50	OTHER PROFESSIONAL SE	1,358.03	



ACCOUNTS PAYABLE CHECK RUN REPORT

0001	00145124	SBD - PAVED STREETS	0001-0500-451-45124-01-100-05-000-6452	WATER/SEWER - UTILITY	80.94	26,749.27
0001	00145124	SBD - PAVED STREETS	0001-0500-451-45124-01-100-05-000-6514	RENTAL OF EQUIPMENT	165.20	169.36
0001	00145124	SBD - PAVED STREETS	0001-0500-451-45124-01-100-05-000-6516	UNIFORMS RUGS ETC. RE	247.38	6,650.73
0001	00145125	SBD - DRAINAGE	0001-0500-451-45125-01-100-05-000-6316	MOTOR VEHICLE REPAIR	4,809.12	6,863.00
0001	00145125	SBD - DRAINAGE	0001-0500-451-45125-01-100-05-000-6419	OTHER PROFESSIONAL SE	300.50	218.23
0001	00145125	SBD - DRAINAGE	0001-0500-451-45125-01-100-05-000-6419	UNIFORMS RUGS ETC. RE	612.53	1,210.11
0001	00145125	SBD - DRAINAGE	0001-0500-451-45125-01-100-05-000-6516	OTHER REPAIR & MAINT	988.79	1,065.13
0001	00145300	CARE & MAINT OF PUBLI	0001-0500-453-45300-01-100-05-000-6317	ELECTRIC LIGHT AND PO	72,416.98	146,888.22
0001	00145300	CARE & MAINT OF PUBLI	0001-0500-453-45300-01-100-05-000-6451	WATER/SEWER - UTILITY	1,232.60	174,667.80
0001	00145300	CARE & MAINT OF PUBLI	0001-0500-453-45300-01-100-05-000-6461	BUILDINGS MAINTENANCE	7,020.79	24,856.53
0001	00145300	CARE & MAINT OF PUBLI	0001-0500-453-45300-01-100-05-000-6464	MACHINE/EQUIP MAINTEN	1,582.33	65.85
0001	00145300	CARE & MAINT OF PUBLI	0001-0500-453-45300-01-100-05-000-6468	PERFORMANCE CONTRACTS	5,207.75	100,164.41
0001	00145300	CARE & MAINT OF PUBLI	0001-0500-453-45300-01-100-05-000-6514	RENTAL OF EQUIPMENT	159.39	2,188.73
0001	00145300	CARE & MAINT OF PUBLI	0001-0500-453-45300-01-100-05-000-6516	UNIFORMS RUGS ETC. RE	251.64	-156.77
0001	00145300	CARE & MAINT OF PUBLI	0001-0500-453-45300-01-100-05-000-6516	INTEREST ON DEBT	14,808.33	-5,181.79
0001	00145300	CARE & MAINT OF PUBLI	0001-0500-453-45300-01-100-05-000-6512	LEASE-ENERGY EFF/BLDG	186,946.54	4,474.70
0001	00145400	CARE & MAINT OF PUBLI	0001-0700-454-45400-01-100-01-000-6451	ELECTRIC LIGHT AND PO	1,686.91	691,471.51
0001	00145400	STREET LIGHTING	0001-0500-456-45610-01-100-05-000-6218	OFFICE SUPPLIES	2,856.68	902.49
0001	00145610	VEHICLE MANAGEMENT AD	0001-0500-456-45610-01-100-05-000-6299	OTHER OPERATING SUPPL	505.80	543.79
0001	00145610	VEHICLE MANAGEMENT AD	0001-0500-456-45610-01-100-05-000-6316	MOTOR VEHICLE REPAIR	1,098.93	24.43
0001	00145610	VEHICLE MANAGEMENT AD	0001-0500-456-45610-01-100-05-000-6452	WATER/SEWER - UTILITY	315.44	31,316.90
0001	00145700	CUSTODIAL SERVICES	0001-0500-457-45700-01-100-05-000-6213	CLEANING & SANITATION	136.00	782.76
0001	00145700	CUSTODIAL SERVICES	0001-0500-457-45700-01-100-05-000-6516	UNIFORMS RUGS ETC. RE	357.50	712.91
0001	00146130	P W-DEPUTY DIR OF ADM	0001-0500-461-46110-01-100-05-000-6240	NON-CAPITALIZED EQUIP	869.05	2,650.00
0001	00146130	P W-DEPUTY DIR OF ADM	0001-0500-461-46130-01-100-05-000-6218	UNIFORMS RUGS ETC. RE	988.25	600.00
0001	00146130	P W-PARKING METER SE	0001-0500-461-46130-01-100-05-000-6516	ELECTRIC LIGHT AND PO	424.09	3,256.99
0001	00149100	MUNICIPAL ART BUILDIN	0001-0200-491-49100-01-100-06-000-6451	WATER/SEWER - UTILITY	440.05	3,100.00
0001	00149100	MUNICIPAL ART BUILDIN	0001-0200-491-49100-01-100-06-000-6452	DUES MEMB. REGIS FEES	9,181.00	48,477.70
0001	00149300	MISC. ADMIN DEPARTMEN	0001-0600-493-49300-01-100-07-000-6443	RENTAL OF EQUIPMENT	320.39	562.42
0001	00149700	INTERNAL AUDIT	0001-0600-497-49700-01-100-01-000-6514			
FUND TOTAL					850,160.15	
0003	00390825	H I D T A - GRANT	0003-0400-908-90825-01-100-04-000-6847	DATA PROCESSING EQUIP	49,666.67	0.00
FUND TOTAL					49,666.67	
0004	00490400	COMPUTER POOL	0004-1200-904-90400-01-100-01-000-6419	OTHER PROFESSIONAL SE	16,450.00	147,750.16
0004	00490400	COMPUTER POOL	0004-1200-904-90400-01-100-01-000-6461	BUILDINGS MAINTENANCE	1,120.00	468.32
FUND TOTAL					17,570.00	
0005	005	PARKS & RECR. FUND	0005-0000-000-00000-02-210-00-000-2332	SPECIAL PROGRAMS-RECR	665.00	2,079.99
0005	00550110	ADMIN PARKS & RECREAT	0005-1100-501-50110-02-210-06-000-6419	OTHER PROFESSIONAL SE	2,920.00	5,500.00
0005	00550110	ADMIN PARKS & RECREAT	0005-1100-501-50110-02-210-06-000-6512	BUILDING RENTAL	1,000.00	

ACCOUNTS PAYABLE CHECK RUN REPORT

0005	00550110	ADMIN PARKS & RECREAT	0005-1100-501-501110-02-210-06-000-66112	INTEREST ON DEBT	485.45	738.59
0005	00550110	ADMIN PARKS & RECREAT	0005-1100-501-501110-02-210-06-000-69223	LEASE PURCHASE BUILDI	2,548.62	715.57
0005	00550125	PROGRAMMING	0005-1100-501-50125-02-210-06-000-6315	ELECTRICAL MATERIALS	179.00	189.03
0005	00550125	PROGRAMMING	0005-1100-501-50125-02-210-06-000-6419	OTHER PROFESSIONAL SE	2,111.40	204.08
0005	00550125	PROGRAMMING	0005-1100-501-50125-02-210-06-000-6451	ELECTRIC LIGHT AND PO	807.16	10,800.63
0005	00550125	PROGRAMMING	0005-1100-501-50125-02-210-06-000-6452	WATERSEWER - UTILITY	874.22	60,253.13
0005	00550126	PROGRAMMING	0005-1100-501-50126-02-210-06-000-6461	BUILDINGS MAINTENANCE	1,297.00	227.41
0005	00550126	ATHLETICS	0005-1100-501-50126-02-210-06-000-6299	OTHER OPERATING SUPPL	9.95	79.68
0005	00550126	ATHLETICS	0005-1100-501-50126-02-210-06-000-6311	BUILDING MATERIALS	92.98	167.78
0005	00550126	ATHLETICS	0005-1100-501-50126-02-210-06-000-6315	ELECTRICAL MATERIALS	754.07	1,764.07
0005	00550126	ATHLETICS	0005-1100-501-50126-02-210-06-000-6419	OTHER PROFESSIONAL SE	1,121.00	271.85
0005	00550140	TENNIS COURTS	0005-1100-501-50140-02-210-06-000-6315	ELECTRICAL MATERIALS	279.00	817.95
0005	00550140	TENNIS COURTS	0005-1100-501-50140-02-210-06-000-6419	OTHER PROFESSIONAL SE	432.00	437.75
0005	00550140	TENNIS COURTS	0005-1100-501-50140-02-210-06-000-6451	ELECTRIC LIGHT AND PO	2,048.26	4,405.79
0005	00550180	AQUATICS	0005-1100-501-50180-02-210-06-000-6311	BUILDING MATERIALS	39.71	1,585.44
0005	00550180	AQUATICS	0005-1100-501-50180-02-210-06-000-6451	ELECTRIC LIGHT AND PO	221.30	578.51
0005	00550180	AQUATICS	0005-1100-501-50180-02-210-06-000-6452	WATERSEWER - UTILITY	302.51	55,685.02
0005	00550410	PARKS - MAINTENANCE	0005-1100-504-50410-02-210-06-000-6211	AGRI + BOT-SEED FERT	4,753.00	653.13
0005	00550410	PARKS - MAINTENANCE	0005-1100-504-50410-02-210-06-000-6299	OTHER OPERATING SUPPL	338.96	8.39
0005	00550410	PARKS - MAINTENANCE	0005-1100-504-50410-02-210-06-000-6317	OTHER REPAIR & MAINT	1,349.22	1.29
0005	00550410	PARKS - MAINTENANCE	0005-1100-504-50410-02-210-06-000-6422	FREIGHT EXPRESS & TRU	470.51	0.00
0005	00550410	PARKS - MAINTENANCE	0005-1100-504-50410-02-210-06-000-6451	ELECTRIC LIGHT AND PO	67.57	13,534.56
0005	00550410	PARKS - MAINTENANCE	0005-1100-504-50410-02-210-06-000-6464	MACHINE/EQUIP MAINTEN	5,363.07	758.50
0005	00550430	PARKS - GOLF COURSE MA	0005-1100-504-50430-02-210-06-000-6514	RENTAL OF EQUIPMENT	7,980.74	4,167.79
0005	00550453	CEMETERIES/GROUNDS MA	0005-1100-504-50453-02-210-06-000-6452	WATERSEWER - UTILITY	52.93	762.02
0005	00550460	PARKS - BASEBALL STADU	0005-1100-504-50460-02-210-06-000-6451	ELECTRIC LIGHT AND PO	4,987.34	7,408.96
0005	00550460	PARKS - BASEBALL STADU	0005-1100-504-50460-02-210-06-000-6452	WATERSEWER - UTILITY	138.34	5,120.95
0005	00550480	PARKS - MYNELLE GARDE	0005-1100-504-50480-02-210-06-000-6230	HAND TOOLS	159.96	404.03
0005	00550480	PARKS - MYNELLE GARDE	0005-1100-504-50480-02-210-06-000-6451	ELECTRIC LIGHT AND PO	31.69	2,237.11
0005	00550480	PARKS - MYNELLE GARDE	0005-1100-504-50480-02-210-06-000-6452	WATERSEWER - UTILITY	250.32	266.30
FUND TOTAL					44,132.28	
0009	00945510	ADMINISTRATIVE - SANI	0009-0500-455-45510-05-550-17-000-6316	MOTOR VEHICLE REPAIR	90.99	1,056.84
0009	00945510	ADMINISTRATIVE - SANI	0009-0500-455-45510-05-550-17-000-6426	TIPPING FEES	93,496.93	190,735.24
0009	00950610	LANDFILL OPERATIONS	0009-0500-506-50610-05-550-17-000-6316	MOTOR VEHICLE REPAIR	11,155.15	1,434.69
0009	00950610	LANDFILL OPERATIONS	0009-0500-506-50610-05-550-17-000-6451	ELECTRIC LIGHT AND PO	654.87	29.59
0009	00950610	LANDFILL OPERATIONS	0009-0500-506-50610-05-550-17-000-6516	UNIFORMS RUGS ETC. RE	212.70	21.87
FUND TOTAL					105,610.64	
0018	01851820	STATE TORT ADMINISTRA	0018-0600-518-51820-01-118-01-000-6722	CLAIMS AGAINST CITY	8,292.03	13,254.92
FUND TOTAL					8,292.03	

ACCOUNTS PAYABLE CHECK RUN REPORT

0031	03152010	WATERSEWER BUSINESS	0031-0500-520-52010-05-511-14-000-6421	POSTAGE P O BOX RENT	30,998.49	6,471.84
0031	03152010	WATERSEWER BUSINESS	0031-0500-520-52010-05-511-14-000-6451	ELECTRIC LIGHT AND PO	484.36	3,686.98
0031	03152010	WATERSEWER BUSINESS	0031-0500-520-52010-05-511-14-000-6612	INTEREST ON DEBT	2,511.29	3,820.53
0031	03152010	WATERSEWER BUSINESS	0031-0500-520-52010-05-511-14-000-6923	LEASE PURCHASE BUILDI	13,184.25	3,697.06
0031	03152130	FEWELL WTR PLNT WELLS	0031-0500-521-52130-05-511-14-000-6451	ELECTRIC LIGHT AND PO	27.42	96,980.73
0031	03152135	O B CURTIS WATER PLAN	0031-0500-521-52135-05-511-14-000-6454	TELEPHONE	0.26	1.72
0031	03152210	ADMINISTRATIVE	0031-0500-522-52210-05-511-14-000-6299	OTHER OPERATING SUPPL	23.25	374.13
0031	03152210	ADMINISTRATIVE	0031-0500-522-52210-05-511-14-000-6316	MOTOR VEHICLE REPAIR	574.00	475.63
0031	03152210	ADMINISTRATIVE	0031-0500-522-52210-05-511-14-000-6419	OTHER PROFESSIONAL SE	21,476.00	0.00
0031	03152215	MAINTENANCE SUPPLY	0031-0500-522-52215-05-511-14-000-6299	OTHER OPERATING SUPPL	277.25	70.46
0031	03152215	MAINTENANCE SUPPLY	0031-0500-522-52215-05-511-14-000-6514	RENTAL OF EQUIPMENT	103.85	502.35
0031	03152215	MAINTENANCE SUPPLY	0031-0500-522-52215-05-511-14-000-6516	UNIFORMS RUGS ETC. RE	153.96	215.53
0031	03152220	OPERATION & MAINTENAN	0031-0500-522-52220-05-511-14-000-6218	OFFICE SUPPLIES	174.57	245.77
0031	03152220	OPERATION & MAINTENAN	0031-0500-522-52220-05-511-14-000-6299	OTHER OPERATING SUPPL	1,340.00	12.75
0031	03152220	OPERATION & MAINTENAN	0031-0500-522-52220-05-511-14-000-6316	MOTOR VEHICLE REPAIR	14.90	6,186.27
0031	03152220	OPERATION & MAINTENAN	0031-0500-522-52220-05-511-14-000-6419	OTHER PROFESSIONAL SE	300.50	609.00
0031	03152220	OPERATION & MAINTENAN	0031-0500-522-52220-05-511-14-000-6465	AUTO + TRUCK GARAGE +	12,629.60	1,160.00
0031	03152225	SEWER EVALUATION SERV	0031-0500-522-52225-05-511-14-000-6516	UNIFORMS RUGS ETC. RE	429.42	2,997.32
0031	03152225	SEWER EVALUATION SERV	0031-0500-522-52225-05-511-14-000-6213	CLEANING & SANITATION	223.84	47.00
0031	03152225	SEWER EVALUATION SERV	0031-0500-522-52225-05-511-14-000-6299	OTHER OPERATING SUPPL	132.46	7.09
0031	03152240	FIELD O & M TESTING	0031-0500-522-52240-05-511-14-000-6451	ELECTRIC LIGHT AND PO	468.55	1,666.25
FUND TOTAL					85,528.22	
0057	057	EMPLOYEES GROUP INSUR	0057-0000-000-00000-06-610-000-000-2102	ACCOUNTS PAYABLE	52,926.93	90,326.37
0057	05755820	MEDICAL BENEFITS	0057-0930-558-55820-06-610-07-000-6419	OTHER PROFESSIONAL SE	47,000.04	18,361.04
0057	05755830	LIFE INSURANCE	0057-0930-558-55830-06-610-07-000-6495	LIFE INS OR SPECIFIC	6,839.20	245,243.85
0057	05755870	EXCESS RISK HEALTH	0057-0930-558-55870-06-610-07-000-6495	LIFE INS OR SPECIFIC	53,797.20	
FUND TOTAL					160,563.37	
0076	07640145	KELLOGG FOUNDATION PR	0076-0600-401-40145-02-230-01-000-6419	OTHER PROFESSIONAL SE	6,041.67	261,088.88
FUND TOTAL					6,041.67	
0079	079	PAYROLL FUND	0079-0000-000-00000-01-100-00-000-2250	EMPL WITHHOLDINGS/GAR	762.84	
FUND TOTAL					762.84	
0085	08571534	CDBG- GENESIS AND LIG	0085-0700-715-71534-02-220-02-000-6742	CONTRIBUTION TO OTHER	12,990.69	0.00
0085	08580812	CC- JACKSON VICTIM SE	0085-0700-808-80812-02-220-02-000-6742	CONTRIBUTION TO OTHER	6,265.38	0.00
0085	08580910	CDBG ADMINISTRATION	0085-0700-809-80910-02-220-02-000-6443	DUES MEM. REGIS FEES	1,095.00	1,455.00
0085	08580910	CDBG ADMINISTRATION	0085-0700-809-80910-02-220-02-000-6473	TRAVEL EXPENSE - OUT	936.32	1,053.17
0085	08580910	CDBG ADMINISTRATION	0085-0700-809-80910-02-220-02-000-6474	AIR TRAVEL	2,119.23	2,600.11
0085	08580920	OFFICE OF HSNIG & COMM	0085-0700-809-80920-02-220-02-000-6443	DUES MEM. REGIS FEES	2,190.00	749.00

City of Jackson

ACCOUNTS PAYABLE CHECK RUN REPORT



0085	08580920	OFFICE OF HSN& & COMM	0085-0700-809-80920-02-220-02-000-6473	TRAVEL EXPENSE - OUT	1,872.64	2,987.62
0085	08580920	OFFICE OF HSN& & COMM	0085-0700-809-80920-02-220-02-000-6474	AIR TRAVEL	2,643.20	5,591.36
0085	08584510	LERP	0085-0700-845-84510-02-220-02-000-6485	CONTRACT CONSTRUCTION	69,300.00	897,088.00
0085	08584610	JAMBOREE DAYCARE CENT	0085-0700-846-84610-02-220-05-000-6742	CONTRIBUTION TO OTHER	1,900.00	0.00
0085	08592110	FIRE STATION REHAB ANI	0085-0700-921-92110-02-220-04-000-6419	OTHER PROFESSIONAL SE	15,700.00	18,096.40
0085	08596410	LEAD-BASED PAINT HAZA	0085-0700-964-96410-02-220-02-000-6443	DUES MEM. REGIS FEES	2,539.50	1,215.00
0085	08596410	LEAD-BASED PAINT HAZA	0085-0700-964-96410-02-220-02-000-6734	CONT-CITY MATCH FED G	13,250.00	328,499.00
0085	08596430	LEAD INTRVTN ACTIVITI	0085-0700-964-96430-02-220-02-000-6485	CONTRACT CONSTRUCTION	29,232.00	600,000.00
0085	08596440	HEALTHY HOMES SUPPLM	0085-0700-964-96440-02-220-02-000-6485	CONTRACT CONSTRUCTION	30,733.00	100,000.00

0086	08659510	BILLY BRUMFIELD SHELT	0086-0700-595-59510-02-220-02-000-6742	FUND TOTAL	192,766.96	
0086	08659520	MATT'S HOUSE	0086-0700-595-59520-02-220-02-000-6742	CONTRIBUTION TO OTHER	4,310.56	0.00
				CONTRIBUTION TO OTHER	937.52	0.00
				FUND TOTAL	5,248.08	
0122	12256615	HOPWA - GRACE HOUSE	0122-0700-566-56615-02-220-02-000-6742	CONTRIBUTION TO OTHER	104,252.51	845,734.38
				FUND TOTAL	104,252.51	

0173	17345190	1% ENGINEERING CAPITA	0173-0500-451-45190-04-400-05-000-6823	IMPROVEMENT OTHER THA	32,562.48	0.00
0173	17345190	1% ENGINEERING CAPITA	0173-0500-451-45190-04-400-05-000-6824	IMPROVEMENT OTHER THA	93,675.35	2,129,069.74
				FUND TOTAL	126,237.83	
0174	17494400	MADISON SEWAGE DISP O	0174-0500-944-94400-05-530-16-000-6451	ELECTRIC LIGHT AND PO	39.23	89.03
				FUND TOTAL	39.23	

0187	18756510	JATRA-OPERATING ASSI	0187-0700-565-56510-05-540-15-000-6425	PUBLIC TRANSPORTATION	282,391.49	1,187,546.20
0187	18756510	JATRA-OPERATING ASSI	0187-0700-565-56510-05-540-15-000-6461	BUILDINGS MAINTENANCE	7,190.00	111,834.67
0187	18756520	TRANSIT SERVICES DIVI	0187-0700-565-56520-05-540-15-000-6213	CLEANING & SANITATION	684.65	0.00
0187	18756520	TRANSIT SERVICES DIVI	0187-0700-565-56520-05-540-15-000-6231	COMPUTER SOFTWARE	114,777.00	315,923.99
0187	18756520	TRANSIT SERVICES DIVI	0187-0700-565-56520-05-540-15-000-6422	FREIGHT EXPRESS & TRU	29.55	556.02
0187	18756520	TRANSIT SERVICES DIVI	0187-0700-565-56520-05-540-15-000-6443	DUES MEM. REGIS FEES	1,590.00	11,600.00
0187	18756520	TRANSIT SERVICES DIVI	0187-0700-565-56520-05-540-15-000-6444	LEGAL ADS ADVERTISING	92.40	7,660.16
0187	18756520	TRANSIT SERVICES DIVI	0187-0700-565-56520-05-540-15-000-6454	TELEPHONE	3,471.09	128,516.70
0187	18756520	TRANSIT SERVICES DIVI	0187-0700-565-56520-05-540-15-000-6455	CELLULAR PHONES	5,302.56	3,554.65
0187	18756520	TRANSIT SERVICES DIVI	0187-0700-565-56520-05-540-15-000-6473	TRAVEL EXPENSE - OUT	203.93	20,426.51
0187	18756520	TRANSIT SERVICES DIVI	0187-0700-565-56520-05-540-15-000-6474	AIR TRAVEL	1,598.98	12,128.30
0187	18756530	CAPITAL MAINTENANCE	0187-0700-565-56530-05-540-15-000-6514	RENTAL OF EQUIPMENT	604.84	36,040.77
				MISC. AUTOMOTIVE EQUI	65,551.37	544,043.25
				FUND TOTAL	483,487.86	

Report generated: 05/18/2023 10:26:37
 User: Gloria Jones (glojre)
 Program ID: gpwerrrt

City of Jackson

ACCOUNTS PAYABLE CHECK RUN REPORT

0203 20355900 JXN CONVENTION & VISI 0203-0600-559-55900-07-710-01-000-67771

APPROP. CONV. + VISIT 333,480.60

0300	30044346	P.A./G.A. OPERATIONAL	0300-0600-443-44346-01-100-01-000-6612	FUND TOTAL	333,480.60	0.00
0300	30044346	P.A./G.A. OPERATIONAL	0300-0600-443-44346-01-100-01-000-6923	INTEREST ON DEBT	1,166.61	1,774.70
				LEASE PURCHASE BUILDI	6,124.67	1,717.96

0376	37652010	WATER ADMINISTRATIVE	0376-0500-520-52010-05-510-14-000-6419	FUND TOTAL	7,291.28	
0376	37652010	WATER ADMINISTRATIVE	0376-0500-520-52010-05-510-14-000-6514	OTHER PROFESSIONAL SE	272,399.62	5,808,548.42
				RENTAL OF EQUIPMENT	18,455.14	0.00

0379	37971513	STEWOPOT COMMUNITY SER	0379-0700-715-71513-02-220-02-000-6742	FUND TOTAL	290,854.76	
				CONTRIBUTION TO OTHER	3,487.28	136,597.04

0382	38271530	CDBG COVID CARES	0382-0700-715-71530-02-220-02-000-6455	FUND TOTAL	3,487.28	
0382	38271530	CDBG COVID CARES	0382-0700-715-71530-02-220-02-000-6514	CELLULAR PHONES	329.84	0.02
0382	38271530	STOREFRONT IMPROVEMEN	0382-0700-715-71532-02-220-02-000-6419	RENTAL OF EQUIPMENT	457.45	5,556.98
0382	38271535	CDBG COVID STEWPOT	0382-0700-715-71535-02-220-02-000-6742	OTHER PROFESSIONAL SE	2,120.00	22,360.00
				CONTRIBUTION TO OTHER	30,237.89	181,078.59

0390	39049800	ZOOLOGICAL PARK	0390-1100-498-49800-02-210-06-000-6211	FUND TOTAL	33,145.18	
0390	39049800	ZOOLOGICAL PARK	0390-1100-498-49800-02-210-06-000-6214	AGRI + BOT-SEED FERT	2,904.64	853.00
0390	39049800	ZOOLOGICAL PARK	0390-1100-498-49800-02-210-06-000-6215	FEED FOR ANIMALS	4,723.56	22,492.57
0390	39049800	ZOOLOGICAL PARK	0390-1100-498-49800-02-210-06-000-6311	FUEL USAGE	6.50	2,917.29
0390	39049800	ZOOLOGICAL PARK	0390-1100-498-49800-02-210-06-000-6317	BUILDING MATERIALS	4,950.00	6,140.25
0390	39049800	ZOOLOGICAL PARK	0390-1100-498-49800-02-210-06-000-6422	OTHER REPAIR & MAINT	272.21	1,379.54
0390	39049800	ZOOLOGICAL PARK	0390-1100-498-49800-02-210-06-000-6461	FREIGHT EXPRESS & TRU	1,107.93	0.00
				BUILDINGS MAINTENANCE	4,990.00	1,243.72

0392	39251107	2019 \$7 MILLION NOTE	0392-0920-511-51107-03-300-09-000-6612	FUND TOTAL	18,954.84	
				INTEREST ON DEBT	113,750.00	0.35

0404	40450133	DFA-SB2971-PETE BROWN	0404-1100-501-50133-02-230-06-000-6240	FUND TOTAL	113,750.00	
0404	40450133	DFA-SB2971-PETE BROWN	0404-1100-501-50133-02-230-06-000-6419	NON-CAPITALIZED EQUIP	9,496.00	6,344.54
				OTHER PROFESSIONAL SE	3,550.00	275,882.62

0406	40643350	DFA- THALIA MARA HALL	0406-0200-433-43350-02-230-06-000-6246	FUND TOTAL	13,046.00	
				OFFICE FURNITURE AND	19,566.12	0.00

Report generated: 05/18/2023 10:26:37
 User: Gloria Jones (ghonji)
 Program ID: apsmwrt



City of Jackson

ACCOUNTS PAYABLE CHECK RUN REPORT

0406 40643350 DFA- THALIA MARA HALL 0406-0200-433-43350-02-230-06-000-6419



Account ID	Description	Other Professional SE	FUND TOTAL	Improvement Other THA	FUND TOTAL	Other Professional SE	FUND TOTAL
0420	42045190 MDOT- CMPDD PROJECTS	14,231.25	33,797.37	281,026.05	281,026.05	9,932.89	9,932.89
	0420-0500-451-45190-02-220-05-000-6824			6,306,220.00			
0430	43040820 2022 GO PLANETARIUM B				281,026.05		
	0430-0200-408-40820-04-400-09-000-6419						
WARRANT SUMMARY TOTAL			3,379,126.59				
GRAND TOTAL			3,379,126.59				

#20

ARTICLE 10 SECTION 10.05 FORNEY
K. H. HAWKINS
5/19/2023

AGENDA DATE: May 23, 2023

ORDER APPROVING GROSS PAYROLL INCLUDING PAYROLL DEDUCTION CLAIMS NUMBERED 28848 TO AND MAKING APPROPRIATION FOR THE PAYMENT THEREOF.

IT IS HEREBY ORDERED that payroll deduction claims numbered 28848 to inclusive therein, in the Municipal "Docket of Claims", in the aggregate amount of \$98,025.48 plus payroll, are approved for payment and necessary amounts are appropriated from various municipal funds for transfer to the payroll fund for the immediate payment thereof.

IT IS FINALLY ORDERED that the following expenditures from the accounts payable fund be made in order to pay amounts transferred thereto from the payroll fund for payment of the payroll deduction claims authorized herein for payment:

Fund	Fund Description	Amount
0079	PAYROLL FUND	\$ 98,025.48
		<u>\$ 98,025.48</u>

APPROVED FOR AGENDA
DEPARTMENT DIRECTOR
LEGAL
CAO
CFO
MAYOR'S OFFICE
ITEM # _____
AGENDA DATE 05/23/2023
BY: THAMES, LUMUMBA

INITIALS	DATE
S.T.	05/19/2023
K.H.A.	5/19/2023
Z.W.P.	5/19/23
F.M.	05/19/23
CAL	5/19/23

CITY OF JACKSON, MISSISSIPPI
Office of the City Attorney

455 East Capitol Street
Post Office Box 2779
Jackson, Mississippi 39207-2779
Telephone: (601) 960-1799
Facsimile: (601) 960-1756

OFFICE OF THE CITY ATTORNEY
Keyona Stewart
5/19/2023

OFFICE OF THE CITY ATTORNEY

The **PAYROLL DEDUCTION CLAIMS DOCKET** for May 23, 2023 in
the aggregate amount of \$ 98,025.48 has been reviewed by me and, based on
information and belief, this document is approved as to form pursuant to Miss. Code Ann. § 21-
39-7 for entry into NOVUS Agenda System and for payment authorization by governing
authorities.



Keyona Stewart

Deputy City Attorney

DATE

5/19/2023

ACCOUNTS PAYABLE CHECK RUN REPORT

Detail Invoice List

CHECK RUN: PD052323 05/23/2023
 DUE DATE: 05/23/2023

ES AGENCY
 5/19/2023
 MUMINIS
 a first step solution

VENDOR	CASH ACCOUNT	999	1100	REMIT	PO	TYPE	DUE DATE	INVOICE	AMOUNT	DOCUMENT	VOUCHER	CHECK
60028	3P BENEFIT SOLUTIONS			0000		EFT	05/12/2023	91426		91426		
	ACCOUNT DETAIL							LINE AMOUNT				
	1 079	2212				PAYROLL F FLEX PRM		25.77				
60028	3P BENEFIT SOLUTIONS			0000		EFT	05/11/2023	91472		91472		
	ACCOUNT DETAIL							LINE AMOUNT				
	1 079	2212				PAYROLL F FLEX PRM		4,623.35				
60028	3P BENEFIT SOLUTIONS			0000		EFT	05/19/2023	91855		91855		
	ACCOUNT DETAIL							LINE AMOUNT				
	1 079	2212				PAYROLL F FLEX PRM		25.77				
								CHECK TOTAL	25.77			
									4,623.35			
523	AFLAC			0000		INV	05/12/2023	91417		91417		
	ACCOUNT DETAIL							LINE AMOUNT				
	1 079	2250				PAYROLL F EMPL WITH		134.49				
523	AFLAC			0000		INV	05/11/2023	91442		91442		
	ACCOUNT DETAIL							LINE AMOUNT				
	1 079	2250				PAYROLL F EMPL WITH		18,744.92				
								CHECK TOTAL	19,013.90			
									134.49			
914	AKILAH IFE RICHARDSON			0000		EFT	05/11/2023	91462		91462		
	ACCOUNT DETAIL							LINE AMOUNT				
	1 079	2250				PAYROLL F EMPL WITH		138.46				
								CHECK TOTAL	138.46			
72016	ALLEN MIRANDA			0000		INV	05/11/2023	91488		91488		
	ACCOUNT DETAIL							LINE AMOUNT				
	1 079	2250				PAYROLL F EMPL WITH		120.00				

ACCOUNTS PAYABLE CHECK RUN REPORT

Detail Invoice List

CHECK RUN: PD062323 05/23/2023
 DUE DATE: 05/23/2023

VENDOR	CASH ACCOUNT: 999	1100	REMIT	PO	TYPE	DUE DATE	INVOICE	AMOUNT	DOCUMENT	VOUCHER	CHECK
530	AMERICAN GENERAL LIFE	0000			INV	05/11/2023	91444				
	ACCOUNT DETAIL						CHECK TOTAL	120.00			
1	079	2250			PAYROLL F EMPL WITH		91444				
							LINE AMOUNT	163.48			
							CHECK TOTAL	163.48			
765	AMERICAN HERITAGE LIF	0000			INV	05/12/2023	91423				
	ACCOUNT DETAIL						LINE AMOUNT	369.39			
1	079	2250			PAYROLL F EMPL WITH		91423				
							LINE AMOUNT	369.39			
							CHECK TOTAL	369.39			
765	AMERICAN HERITAGE LIF	0000			INV	05/11/2023	91455				
	ACCOUNT DETAIL						LINE AMOUNT	4,259.86			
1	079	2250			PAYROLL F EMPL WITH		91455				
							LINE AMOUNT	4,259.86			
							CHECK TOTAL	4,259.86			
765	AMERICAN HERITAGE LIF	0000			INV	05/19/2023	91852				
	ACCOUNT DETAIL						LINE AMOUNT	369.39			
1	079	2250			PAYROLL F EMPL WITH		91852				
							LINE AMOUNT	369.39			
							CHECK TOTAL	4,998.64			
653	AMERICAN-AMICABLE LIF	0000			INV	05/11/2023	91448				
	ACCOUNT DETAIL						LINE AMOUNT	2,008.74			
1	079	2250			PAYROLL F EMPL WITH		91448				
							LINE AMOUNT	2,008.74			
							CHECK TOTAL	2,008.74			
72891	ANGEL LONGINO	0000			INV	05/11/2023	91489				
	ACCOUNT DETAIL						LINE AMOUNT	274.00			
1	079	2250			PAYROLL F EMPL WITH		91489				
							LINE AMOUNT	274.00			
							CHECK TOTAL	274.00			
746	BARBOUR IV JEPHTHA F	0000			INV	05/11/2023	91453				
	ACCOUNT DETAIL						LINE AMOUNT	421.43			
1	079	2250			PAYROLL F EMPL WITH		91453				
							LINE AMOUNT	421.43			
							CHECK TOTAL	421.43			



ACCOUNTS PAYABLE CHECK RUN REPORT

Detail Invoice List

CHECK RUN: PD052323
 DUE DATE: 05/23/2023

05/23/2023

CASH ACCOUNT: 999		1100	POOLED CASH - AP DISBURSEMENTS				INVOICE	AMOUNT	DOCUMENT	VOUCHER	CHECK
VENDOR	REMIT	PO	TYPE	DUE DATE		CHECK TOTAL					
66375	BYRD STEPHANIE		EFT	05/11/2023		91477		91477			
	ACCOUNT DETAIL					LINE AMOUNT					
	1 079	2250	PAYROLL F EMPL WITH			137.50	137.50				
						CHECK TOTAL	137.50				
657	COLONIAL LIFE & ACCID		INV	05/12/2023		91420		91420			
	ACCOUNT DETAIL					LINE AMOUNT					
	1 079	2250	PAYROLL F EMPL WITH			6.00	6.00				
						CHECK TOTAL	6.00				
657	COLONIAL LIFE & ACCID		INV	05/11/2023		91449		91449			
	ACCOUNT DETAIL					LINE AMOUNT					
	1 079	2250	PAYROLL F EMPL WITH			2,029.20	2,029.20				
						CHECK TOTAL	2,041.20				
657	COLONIAL LIFE & ACCID		INV	05/19/2023		91849		91849			
	ACCOUNT DETAIL					LINE AMOUNT					
	1 079	2250	PAYROLL F EMPL WITH			6.00	6.00				
						CHECK TOTAL	2,041.20				
66394	COMPBENEFITS		EFT	05/12/2023		91428		91428			
	ACCOUNT DETAIL					LINE AMOUNT					
	1 079	2214	PAYROLL F VSN PRM			61.74	61.74				
						CHECK TOTAL	2,956.90				
66394	COMPBENEFITS		EFT	05/11/2023		91478		91478			
	ACCOUNT DETAIL					LINE AMOUNT					
	1 079	2214	PAYROLL F VSN PRM			2,833.42	2,833.42				
						CHECK TOTAL	61.74				
66394	COMPBENEFITS		EFT	05/19/2023		91857		91857			
	ACCOUNT DETAIL					LINE AMOUNT					
	1 079	2214	PAYROLL F VSN PRM			61.74	61.74				
						CHECK TOTAL	2,956.90				



ACCOUNTS PAYABLE CHECK RUN REPORT

Detail Invoice List

CHECK RUN: PD052323 05/23/2023
 DUE DATE: 05/23/2023

VENDOR	CASH ACCOUNT: 999	1100	REMIT	PO	TYPE	DUE DATE	INVOICE	AMOUNT	DOCUMENT	VOUCHER	CHECK
501	CRDU		0000		INV	05/12/2023	91415		91415		
	ACCOUNT DETAIL						LINE AMOUNT				
	1 079	2250			PAYROLL F EMPL WITH		942.54				
501	CRDU		0000		INV	05/11/2023	91440		91440		
	ACCOUNT DETAIL						LINE AMOUNT				
	1 079	2250			PAYROLL F EMPL WITH		19,484.79				
501	CRDU		0000		INV	05/19/2023	91844		91844		
	ACCOUNT DETAIL						LINE AMOUNT				
	1 079	2250			PAYROLL F EMPL WITH		692.13				
							CHECK TOTAL	21,119.46			
726	DAVID C. RAWLINGS		0000		INV	05/12/2023	91421		91421		
	ACCOUNT DETAIL						LINE AMOUNT				
	1 079	2250			PAYROLL F EMPL WITH		39.50				
726	DAVID C. RAWLINGS		0000		INV	05/11/2023	91451		91451		
	ACCOUNT DETAIL						LINE AMOUNT				
	1 079	2250			PAYROLL F EMPL WITH		3,116.50				
							CHECK TOTAL	3,195.50			
726	DAVID C. RAWLINGS		0000		INV	05/19/2023	91850		91850		
	ACCOUNT DETAIL						LINE AMOUNT				
	1 079	2250			PAYROLL F EMPL WITH		39.50				
							CHECK TOTAL	3,195.50			
889	DEPARTMENT OF SOCIAL		0000		INV	05/11/2023	91461		91461		
	ACCOUNT DETAIL						LINE AMOUNT				
	1 079	2250			PAYROLL F EMPL WITH		185.52				
							CHECK TOTAL	185.52			
1046	FLORIDA STATE DISBUR		0000		INV	05/11/2023	91469		91469		
	ACCOUNT DETAIL						LINE AMOUNT				
	1 079	2250			PAYROLL F EMPL WITH		184.62				
							CHECK TOTAL	184.62			

ACCOUNTS PAYABLE CHECK RUN REPORT

Detail Invoice List

CHECK RUN: PD052323 05/23/2023
 DUE DATE: 05/23/2023

CASH ACCOUNT: 999		1100	POOLED CASH - AP DISBURSEMENTS				INVOICE	AMOUNT	DOCUMENT	VOUCHER	CHECK
VENDOR	REMIT	PO	TYPE	DUE DATE	INVOICE	AMOUNT	DOCUMENT	VOUCHER	CHECK		
969	FRAZIER SONYA MOZELLA	0000	EFT	05/11/2023	91468	91468					
	ACCOUNT DETAIL				LINE AMOUNT						
	1 079	2250	PAYROLL F EMPL WITH		95.77	95.77					
					CHECK TOTAL	95.77					
					CHECK TOTAL	184.62					
71559	GADDIS THERESA	0000	INV	05/11/2023	91484	91484					
	ACCOUNT DETAIL				LINE AMOUNT						
	1 079	2250	PAYROLL F EMPL WITH		230.77	230.77					
					CHECK TOTAL	230.77					
					CHECK TOTAL	230.77					
6867	GENERAL FUND	0000	INV	05/11/2023	91471	91471					
	ACCOUNT DETAIL				LINE AMOUNT						
	1 079	2250	PAYROLL F EMPL WITH		108.44	108.44					
					CHECK TOTAL	108.44					
					CHECK TOTAL	108.44					
432	H D CATCHINGS AGENCY	0000	INV	05/12/2023	91412	91412					
	ACCOUNT DETAIL				LINE AMOUNT						
	1 079	2250	PAYROLL F EMPL WITH		78.12	78.12					
					CHECK TOTAL	78.12					
					CHECK TOTAL	78.12					
432	H D CATCHINGS AGENCY	0000	INV	05/11/2023	91432	91432					
	ACCOUNT DETAIL				LINE AMOUNT						
	1 079	2250	PAYROLL F EMPL WITH		4,318.49	4,318.49					
					CHECK TOTAL	4,318.49					
					CHECK TOTAL	4,318.49					
432	H D CATCHINGS AGENCY	0000	INV	05/19/2023	91842	91842					
	ACCOUNT DETAIL				LINE AMOUNT						
	1 079	2250	PAYROLL F EMPL WITH		78.12	78.12					
					CHECK TOTAL	78.12					
					CHECK TOTAL	4,474.73					
442	HAROLD J BARKLEY JR,	0000	INV	05/12/2023	91413	91413					
	ACCOUNT DETAIL				LINE AMOUNT						
	1 079	2250	PAYROLL F EMPL WITH		297.00	297.00					
					CHECK TOTAL	297.00					
					CHECK TOTAL	297.00					



ACCOUNTS PAYABLE CHECK RUN REPORT

Detail Invoice List

CHECK RUN: PD052323 05/23/2023
 DUE DATE: 05/23/2023

CASH ACCOUNT: 999		1100		POOLED CASH - AP DISBURSEMENTS						
VENDOR		REMIT	PO	TYPE	DUE DATE	INVOICE	AMOUNT	DOCUMENT	VOUCHER	CHECK
442	HAROLD J BARKLEY JR,	0000		INV	05/11/2023	91433		91433		
	ACCOUNT DETAIL					LINE AMOUNT				
	1 079	2250		PAYROLL F EMPLOYEE WITH			833.00			
						LINE AMOUNT				
						CHECK TOTAL	833.00			
442	HAROLD J BARKLEY JR,	0000		INV	05/19/2023	91843		91843		
	ACCOUNT DETAIL					LINE AMOUNT				
	1 079	2250		PAYROLL F EMPLOYEE WITH			297.00			
						CHECK TOTAL	1,427.00			
743	HART ANGELA	0000		EFT	05/11/2023	91452		91452		
	ACCOUNT DETAIL					LINE AMOUNT				
	1 079	2250		PAYROLL F EMPLOYEE WITH			222.92			
						CHECK TOTAL	222.92			
938	HENLEY BRAND	0000		INV	05/12/2023	91425		91425		
	ACCOUNT DETAIL					LINE AMOUNT				
	1 079	2250		PAYROLL F EMPLOYEE WITH			89.97			
						CHECK TOTAL	89.97			
938	HENLEY BRAND	0000		INV	05/11/2023	91465		91465		
	ACCOUNT DETAIL					LINE AMOUNT				
	1 079	2250		PAYROLL F EMPLOYEE WITH			75.00			
						CHECK TOTAL	75.00			
938	HENLEY BRAND	0000		INV	05/19/2023	91854		91854		
	ACCOUNT DETAIL					LINE AMOUNT				
	1 079	2250		PAYROLL F EMPLOYEE WITH			89.97			
						CHECK TOTAL	254.94			
618	HENLEY PAT	0000		INV	05/11/2023	91446		91446		
	ACCOUNT DETAIL					LINE AMOUNT				
	1 079	2250		PAYROLL F EMPLOYEE WITH			100.00			
						CHECK TOTAL	100.00			

ACCOUNTS PAYABLE CHECK RUN REPORT

Detail Invoice List

CHECK RUN: PD052323 05/23/2023
 DUE DATE: 05/23/2023

CASH ACCOUNT: 999		1100		POOLED CASH - AP DISBURSEMENTS						
VENDOR	REMIT	PO	TYPE	DUE DATE	INVOICE	AMOUNT	DOCUMENT	VOUCHER	CHECK	
453	INTERNAL REVENUE SERV	0000	INV	05/11/2023	91436					
	ACCOUNT DETAIL				LINE AMOUNT					
	1 079	2250	PAYROLL F EMPL WITH		500.80	500.80				
					CHECK TOTAL	500.80				
71815	INTERNAL REVENUE SERV	0000	INV	05/11/2023	91486					
	ACCOUNT DETAIL				LINE AMOUNT					
	1 079	2250	PAYROLL F EMPL WITH		88.00	88.00				
					CHECK TOTAL	88.00				
445	J ALLEN SANDIFER AGEN	0000	INV	05/11/2023	91434					
	ACCOUNT DETAIL				LINE AMOUNT					
	1 079	2250	PAYROLL F EMPL WITH		142.32	142.32				
					CHECK TOTAL	142.32				
63964	JACKSON AREA F C U	0000	INV	05/11/2023	91473					
	ACCOUNT DETAIL				LINE AMOUNT					
	1 079	2250	PAYROLL F EMPL WITH		303.15	303.15				
					CHECK TOTAL	303.15				
848	JACKSON FIREFIGHTERS	0000	EFT	05/11/2023	91456					
	ACCOUNT DETAIL				LINE AMOUNT					
	1 079	2250	PAYROLL F EMPL WITH		2,826.22	2,826.22				
					CHECK TOTAL	2,826.22				
857	JACKSON POLICE OFFICE	0000	EFT	05/11/2023	91457					
	ACCOUNT DETAIL				LINE AMOUNT					
	1 079	2250	PAYROLL F EMPL WITH		1,237.50	1,237.50				
					CHECK TOTAL	1,237.50				



ACCOUNTS PAYABLE CHECK RUN REPORT

Detail Invoice List

CHECK RUN: PD062323 05/23/2023
 DUE DATE: 05/23/2023

CASH ACCOUNT: 999		1100		POOLED CASH - AP DISBURSEMENTS						
VENDOR	REMIT	PO	TYPE	DUE DATE	INVOICE	AMOUNT	DOCUMENT	VOUCHER	CHECK	
915	JACOB LAW GROUP	0000	INV	05/11/2023	91463					
	ACCOUNT DETAIL				LINE AMOUNT					
	1 079	2250	PAYROLL F EMPL WITH		448.44					
					CHECK TOTAL	448.44				
401422	JAYLYNN KIARA FRAZIER	0000	EFT	05/11/2023	91494					
	ACCOUNT DETAIL				LINE AMOUNT					
	1 079	2250	PAYROLL F EMPL WITH		95.77					
					CHECK TOTAL	95.77				
951	JENKINS RUSSELL	0000	INV	05/11/2023	91467					
	ACCOUNT DETAIL				LINE AMOUNT					
	1 079	2250	PAYROLL F EMPL WITH		127.50					
					CHECK TOTAL	127.50				
531	JRA PARKING	0000	INV	05/11/2023	91445					
	ACCOUNT DETAIL				LINE AMOUNT					
	1 079	2250	PAYROLL F EMPL WITH		794.64					
					CHECK TOTAL	794.64				
71814	LEWIS ESCORTIA	0000	EFT	05/11/2023	91485					
	ACCOUNT DETAIL				LINE AMOUNT					
	1 079	2250	PAYROLL F EMPL WITH		138.46					
					CHECK TOTAL	138.46				
415	LIFE OF ALABAMA	0000	INV	05/12/2023	91411					
	ACCOUNT DETAIL				LINE AMOUNT					
	1 079	2250	PAYROLL F EMPL WITH		177.17					
					CHECK TOTAL	177.17				
415	LIFE OF ALABAMA	0000	INV	05/11/2023	91431					
	ACCOUNT DETAIL				LINE AMOUNT					
	1 079	2250	PAYROLL F EMPL WITH		3,103.77					
					CHECK TOTAL	3,103.77				



ACCOUNTS PAYABLE CHECK RUN REPORT

Detail Invoice List

CHECK RUN: PD052323 05/23/2023
 DUE DATE: 05/23/2023

CASH ACCOUNT: 999		1100		POOLED CASH - AP DISBURSEMENTS						
VENDOR		REMIT	PO	TYPE	DUE DATE	INVOICE	AMOUNT	DOCUMENT	VOUCHER	CHECK
415	LIFE OF ALABAMA	0000		INV	05/19/2023	91841		91841		
	ACCOUNT DETAIL					LINE AMOUNT				
	1 079	2250		PAYROLL F EMPL WITH		135.93				
						CHECK TOTAL	135.93			
							3,416.87			
73597	LUNSFORD BASKIN & PRI	0000		INV	05/11/2023	91492		91492		
	ACCOUNT DETAIL					LINE AMOUNT				
	1 079	2250		PAYROLL F EMPL WITH		465.76				
						CHECK TOTAL	465.76			
66559	MARTIN FLORINE	0000		INV	05/11/2023	91479		91479		
	ACCOUNT DETAIL					LINE AMOUNT				
	1 079	2250		PAYROLL F EMPL WITH		137.50				
						CHECK TOTAL	137.50			
877	MASE/CWA	0000		INV	05/12/2023	91424		91424		
	ACCOUNT DETAIL					LINE AMOUNT				
	1 079	2250		PAYROLL F EMPL WITH		86.29				
						CHECK TOTAL	86.29			
							1,005.65			
							91853			
							79.95			
							1,171.89			
65937	MENDELSON LAW FIRM	0000		INV	05/11/2023	91476		91476		
	ACCOUNT DETAIL					LINE AMOUNT				
	1 079	2250		PAYROLL F EMPL WITH		720.65				
						CHECK TOTAL	720.65			



ACCOUNTS PAYABLE CHECK RUN REPORT

Detail Invoice List

CHECK RUN: PD052323 05/23/2023
 DUE DATE: 05/23/2023

CASH ACCOUNT: 999		1100		POOLED CASH - AP DISBURSEMENTS						
VENDOR		REMIT	PO	TYPE	DUE DATE	INVOICE	AMOUNT	DOCUMENT	VOUCHER	CHECK
499	MS DEPARTMENT OF REVE	0000		INV	05/12/2023	91414		91414		
	ACCOUNT DETAIL					LINE AMOUNT				
	1 079 2250			PAYROLL F EMPL WITH		160.00				
	ACCOUNT DETAIL					LINE AMOUNT				
	1 079 2250			PAYROLL F EMPL WITH		2,017.20				
	CHECK TOTAL					2,177.20				
66893	MS DEPT OF EMPLOYMENT	0000		INV	05/11/2023	91480		91480		
	ACCOUNT DETAIL					LINE AMOUNT				
	1 079 2250			PAYROLL F EMPL WITH		203.89				
	CHECK TOTAL					203.89				
512	MS EMPLOYMENT SECURIT	0000		INV	05/12/2023	91416		91416		
	ACCOUNT DETAIL					LINE AMOUNT				
	1 079 2250			PAYROLL F EMPL WITH		560.19				
	ACCOUNT DETAIL					LINE AMOUNT				
	1 079 2250			PAYROLL F EMPL WITH		1,398.56				
	CHECK TOTAL					1,958.75				
490	MS TELCO FEDERAL CRED	0000		INV	05/11/2023	91438		91438		
	ACCOUNT DETAIL					LINE AMOUNT				
	1 079 2250			PAYROLL F EMPL WITH		237.34				
	CHECK TOTAL					237.34				



ACCOUNTS PAYABLE CHECK RUN REPORT

Detail Invoice List

CHECK RUN: PD052323 05/23/2023
 DUE DATE: 05/23/2023

CASH ACCOUNT: 999		1100		POOLED CASH - AP DISBURSEMENTS										
VENDOR		REMIT	PO	TYPE	DUE DATE	INVOICE	AMOUNT	DOCUMENT	VOUCHER	CHECK	LINE AMOUNT	CHECK TOTAL	LINE AMOUNT	CHECK TOTAL
1051	NC CHILD SUPPORT & CE	0000		INV	05/11/2023	91470		91470			235.38	235.38	91470	235.38
	ACCOUNT DETAIL										235.38	CHECK TOTAL		235.38
764	OCCIDENTAL LIFE INSUR	0000		INV	05/12/2023	91422		91422			9.54	9.54	91422	9.54
	ACCOUNT DETAIL										9.54	CHECK TOTAL		9.54
764	OCCIDENTAL LIFE INSUR	0000		INV	05/11/2023	91454		91454			330.60	330.60	91454	330.60
	ACCOUNT DETAIL										330.60	CHECK TOTAL		330.60
764	OCCIDENTAL LIFE INSUR	0000		INV	05/19/2023	91851		91851			9.54	9.54	91851	9.54
	ACCOUNT DETAIL										9.54	CHECK TOTAL		9.54
529	POLICE HOSPITAL FUND	0000		EFT	05/12/2023	91418		91418			4.62	4.62	91418	4.62
	ACCOUNT DETAIL										4.62	CHECK TOTAL		4.62
529	POLICE HOSPITAL FUND	0000		EFT	05/11/2023	91443		91443			720.71	720.71	91443	720.71
	ACCOUNT DETAIL										720.71	CHECK TOTAL		720.71
529	POLICE HOSPITAL FUND	0000		EFT	05/19/2023	91847		91847			4.62	4.62	91847	4.62
	ACCOUNT DETAIL										4.62	CHECK TOTAL		4.62
944	PRE-PAID LEGAL SERVIC	0000		INV	05/11/2023	91466		91466			1,267.37	1,267.37	91466	1,267.37
	ACCOUNT DETAIL										1,267.37	CHECK TOTAL		1,267.37



ACCOUNTS PAYABLE CHECK RUN REPORT

Detail Invoice List

CHECK RUN: PD052323 05/23/2023
 DUE DATE: 05/23/2023

CASH ACCOUNT: 999		1100		POOLED CASH - AP DISBURSEMENTS				INVOICE	AMOUNT	DOCUMENT	VOUCHER	CHECK
VENDOR	REMIT	PO	TYPE	DUE DATE	INVOICE	CHECK TOTAL	AMOUNT	DOCUMENT	VOUCHER	CHECK		
658	PROVIDENT INSURANCE		INV	05/11/2023	91450			91450				
	ACCOUNT DETAIL											
1	079	2250	PAYROLL F EMPL WITH			22.02	22.02					
							22.02					
							CHECK TOTAL					
73572	RAUSCH STURM		INV	05/11/2023	91491			91491				
	ACCOUNT DETAIL											
1	079	2250	PAYROLL F EMPL WITH			162.03	162.03					
							CHECK TOTAL					
928	ROBERTS CASSIE		EFT	05/11/2023	91464			91464				
	ACCOUNT DETAIL											
1	079	2250	PAYROLL F EMPL WITH			130.00	130.00					
							CHECK TOTAL					
884	SANDERS ANTIONETTE LE		EFT	05/11/2023	91460			91460				
	ACCOUNT DETAIL											
1	079	2250	PAYROLL F EMPL WITH			286.15	286.15					
							CHECK TOTAL					
401297	SDUTRIBAL		INV	05/11/2023	91493			91493				
	ACCOUNT DETAIL											
1	079	2250	PAYROLL F EMPL WITH			181.73	181.73					
							CHECK TOTAL					
73251	SHARON WEBBER		INV	05/11/2023	91490			91490				
	ACCOUNT DETAIL											
1	079	2250	PAYROLL F EMPL WITH			327.69	327.69					
							CHECK TOTAL					



ACCOUNTS PAYABLE CHECK RUN REPORT

Detail Invoice List

CHECK RUN: PD052323 05/23/2023
 DUE DATE: 05/23/2023

CASH ACCOUNT: 999		1100		POOLED CASH - AP DISBURSEMENTS							
VENDOR	REMIT	PO	TYPE	DUE DATE	INVOICE	AMOUNT	DOCUMENT	VOUCHER	CHECK		
651 SIMPSON LAW FIRM PA	0000		INV	05/12/2023	91419		91419				
	ACCOUNT DETAIL				LINE AMOUNT						
	1 079	2250	PAYROLL F EMPLOYEE WITH		43.15						
	ACCOUNT DETAIL				LINE AMOUNT	818.78					
				CHECK TOTAL	43.15		91447				
				CHECK TOTAL	818.78		91848				
651 SIMPSON LAW FIRM PA	0000		INV	05/19/2023	91487		91487				
	ACCOUNT DETAIL				LINE AMOUNT						
	1 079	2250	PAYROLL F EMPLOYEE WITH		43.15						
	ACCOUNT DETAIL				LINE AMOUNT	43.15					
				CHECK TOTAL	43.15		905.08				
				CHECK TOTAL	905.08						
70874 SOUTHERN STATES POLIC	0000		INV	05/11/2023	91482		91482				
	ACCOUNT DETAIL				LINE AMOUNT						
	1 079	2250	PAYROLL F EMPLOYEE WITH		1,486.45						
	ACCOUNT DETAIL				LINE AMOUNT	1,486.45					
				CHECK TOTAL	1,486.45						
				CHECK TOTAL	1,486.45						
71944 TATUM VALERIE A	0000		EFT	05/11/2023	91487		91487				
	ACCOUNT DETAIL				LINE AMOUNT						
	1 079	2250	PAYROLL F EMPLOYEE WITH		134.46						
	ACCOUNT DETAIL				LINE AMOUNT	134.46					
				CHECK TOTAL	134.46						
				CHECK TOTAL	134.46						
70838 THE WINN BROWN LAW FI	0000		INV	05/11/2023	91481		91481				
	ACCOUNT DETAIL				LINE AMOUNT						
	1 079	2250	PAYROLL F EMPLOYEE WITH		565.80						
	ACCOUNT DETAIL				LINE AMOUNT	565.80					
				CHECK TOTAL	565.80						
				CHECK TOTAL	565.80						
449 THRASH GARY	0000		INV	05/11/2023	91435		91435				
	ACCOUNT DETAIL				LINE AMOUNT						
	1 079	2250	PAYROLL F EMPLOYEE WITH		818.65						
	ACCOUNT DETAIL				LINE AMOUNT	818.65					
				CHECK TOTAL	818.65						
				CHECK TOTAL	818.65						



ACCOUNTS PAYABLE CHECK RUN REPORT

Detail Invoice List

CHECK RUN: PDD052323 05/23/2023
 DUE DATE: 05/23/2023

CASH ACCOUNT:	999	1100	POOLED CASH - AP DISBURSEMENTS			INVOICE	AMOUNT	DOCUMENT	VOUCHER	CHECK
VENDOR	REMIT	PO	TYPE	DUE DATE	INVOICE					
879	TREASURER OF VIRGINIA	0000	INV	05/11/2023	91459					
	ACCOUNT DETAIL				LINE AMOUNT					
	1 079	2250	PAYROLL F EMPPL WITH		119.52					
					CHECK TOTAL	119.52				
						119.52				
64220	TX CHILDR SUPPORT SDU	0000	INV	05/11/2023	91474					
	ACCOUNT DETAIL				LINE AMOUNT					
	1 079	2250	PAYROLL F EMPPL WITH		69.23					
					CHECK TOTAL	69.23				
						69.23				
478	UNITED WAY	0000	INV	05/11/2023	91437					
	ACCOUNT DETAIL				LINE AMOUNT					
	1 079	2250	PAYROLL F EMPPL WITH		7.00					
					CHECK TOTAL	7.00				
						7.00				
65572	UNUM PROVIDENT LIFE &	0000	INV	05/12/2023	91427					
	ACCOUNT DETAIL				LINE AMOUNT					
	1 079	2250	PAYROLL F EMPPL WITH		178.46					
					CHECK TOTAL	178.46				
						178.46				
65572	UNUM PROVIDENT LIFE &	0000	INV	05/11/2023	91475					
	ACCOUNT DETAIL				LINE AMOUNT					
	1 079	2250	PAYROLL F EMPPL WITH		2,950.24					
					CHECK TOTAL	2,950.24				
						2,950.24				
65572	UNUM PROVIDENT LIFE &	0000	INV	05/19/2023	91856					
	ACCOUNT DETAIL				LINE AMOUNT					
	1 079	2250	PAYROLL F EMPPL WITH		178.01					
					CHECK TOTAL	178.01				
						178.01				
					CHECK TOTAL	3,306.71				
						3,306.71				
401935	WEST SIDE LENDING	0000	INV	05/11/2023	91495					
	ACCOUNT DETAIL				LINE AMOUNT					
	1 079	2250	PAYROLL F EMPPL WITH		159.35					
					CHECK TOTAL	159.35				
						159.35				

ACCOUNTS PAYABLE CHECK RUN REPORT

Detail Invoice List

CHECK RUN: PD052323 05/23/2023
 DUE DATE: 05/23/2023



CASH ACCOUNT: 999		1100		POOLED CASH - AP DISBURSEMENTS					
VENDOR	REMIT	PO	TYPE	DUE DATE	INVOICE	AMOUNT	DOCUMENT	VOUCHER	CHECK
71556 WILKINSON ATTORNEYS A	0000		INV	05/11/2023	91483				
ACCOUNT DETAIL						LINE AMOUNT			
1 079	2250		PAYROLL F EMPL WITH			455.80			
WARRANT TOTAL						98,025.48			
100 INVOICES						98,025.48			
CHECK TOTAL						455.80			
CHECK TOTAL						455.80			

ACCOUNTS PAYABLE CHECK RUN REPORT

Check Run Summary

CHECK RUN: PD052323 05/23/2023
DUE DATE: 05/23/2023



FUND	ORG	ACCOUNT	AMOUNT	AVLB BUDGET
0079	079	PAYROLL FUND		
0079	079	PAYROLL FUND		
0079	079	PAYROLL FUND		
		0079-0000-000-00000-01-100-00-000-2212		
		0079-0000-000-00000-01-100-00-000-2214		
		0079-0000-000-00000-01-100-00-000-2250		
		FLEX PLAN PREMIUM WIT	4,674.89	
		VISION PREMIUM WITHHE	2,956.90	
		EMPL WITHHOLDINGS/GAR	90,393.69	
		FUND TOTAL	98,025.48	
		WARRANT SUMMARY TOTAL	98,025.48	
		GRAND TOTAL	98,025.48	

21

ORDER CONFIRMING THE MAYOR'S APPOINTMENT OF SHARON THAMES AS DIRECTOR OF THE DEPARTMENT OF ADMINISTRATION, CITY OF JACKSON, MISSISSIPPI.

WHEREAS, the Mayor previously appointed Sharon Thames as Interim Director of the Department of Administration for the City of Jackson, Mississippi; and

WHEREAS, the interim appointment expired on or about September 28, 2022, pursuant to Miss. Code Ann. § 21-15-41, Mississippi Code of 1972, as amended, and upon expiration she no longer served in an interim capacity; and

WHEREAS, on May 23, 2023, pursuant to Section 21-8-23(2), Mississippi Code of 1972, as amended, the Mayor appointed Sharon Thames as Director of the Department of Administration for the City of Jackson, Mississippi and the City Council has considered the appointment, and a majority of the Council present and voting has determined that the appointment should be confirmed.

IT IS, THEREFORE, ORDERED by the City Council of the City of Jackson, Mississippi, that the appointment of Sharon Thames as Director of the Department of Administration for the City of Jackson, Mississippi, is hereby confirmed.

No. 21
(LUMUMBA)
May 23, 2023

Office of the City Attorney

455 East Capitol Street
Post Office Box 2779
Jackson, Mississippi 39207-2779
Telephone: (601) 960-1799
Facsimile: (601) 960-1756

OFFICE OF THE CITY ATTORNEY

This **ORDER CONFIRMING THE MAYOR'S APPOINTMENT OF SHARON THAMES AS DIRECTOR OF THE DEPARTMENT OF ADMINISTRATION, CITY OF JACKSON, MISSISSIPPI** is legally sufficient for placement in NOVUS Agenda.



Carrie Johnson, Deputy City Attorney

5/17/2023 Date

OFFICE OF THE CITY ATTORNEY
Carrie Johnson

22

OFFICE OF THE ATTORNEY GENERAL
Lumumba

ORDER AUTHORIZING THE MAYOR TO EXECUTE AN AGREEMENT WITH eCIVIS, Inc FOR SERVICES RELATED TO THE IMPLEMENTATION OF A GRANTS NETWORK SYSTEM AND SUBSCRIPTION TO THE CLOUD HOSTED SaaS GRANTS MANAGEMENT PLATFORM

Whereas, in *Opinion 2016-00070* issued to P. Scott Phillips on March 25, 2016, the Mississippi Attorney General opined that the procurement of software, which is an ancillary part, additional to a main part or function of a procurement itself and is of no use without services necessary to design and implement a system for its use is not required to be bid under Section 31-7-13 of the Mississippi Code; and

Whereas, Carahsoft, is the master government aggregator for eCivis, Inc.; and

Whereas, eCivis, is a cloud-hosted commercial-off-the shelf (COTS) SaaS grants management platform and is specifically built for managing the full grants management lifecycle; and

Whereas, Carahsoft and eCivis, Inc. submitted a proposal to the Mayor's office for the implementation of its grants management platform and subscription for the services; and

Whereas, the proposal submitted to the Mayor's office included both recurring annual fees and non-recurring fees with a loyalty discount of \$5,200.00; and

Whereas, eCivis, Inc., is a part of GTY Technology Holdings, Inc., following acquisition on September 14, 2018; and

Whereas, the cloud hosting program constitutes a service and any software required or implemented is ancillary and necessary for the use of the system as designed and intended and would not be subject to the public purchasing laws as noted in the aforementioned opinion issued by the Mississippi Attorney General; and

Whereas, the initial cost for implementation and use of the cloud hosting program in year one is \$64,947.50; and

Whereas, a five (5) year term was noted on the quotation received from eCivis-Carahsoft; and

Whereas, the cost for the service in the second year would be \$49,825.62; and

Whereas, the cost for the service in third year would be \$53,313.41; and

Whereas, the cost for the service in year four would be \$57,045.35; and

Whereas the cost for the service in the fifth and final year of the agreement would be \$61,038.52; and

Agenda Item No. 22
May 23, 2023
(Lumumba)

Whereas, the total cost for implementation of the program and use of the cloud-hosted services during the five year period is \$286,170.40; and

Whereas, the cost includes plan and design, configuration, readiness assessments, user training, training manuals, and virtual user training; and

Whereas, the best interest of the City of Jackson would be served by contracting with eCIVIS grant management platform;

IT IS HEREBY ORDERED that the Mayor shall be authorized to execute an agreement with eCIVIS for services related to the implementation of a network system and cloud hosted SaaS Grants platform as a service.

OFFICE OF THE CITY ATTORNEY

GOVERNMENT - PRICE QUOTATION

CARASOFT TECHNOLOGY CORP



11493 SUNSET HILLS ROAD | SUITE 100 | RESTON, VIRGINIA 20190
 PHONE (703) 871-8500 | FAX (703) 871-8505 | TOLL FREE (888) 66CARAH
 WWW.CARASOFT.COM | ECIVIS@CARASOFT.COM

TO: Safiya Omari
 Chief of Staff
 City of Jackson, MS
 MS United States

FROM: Garrett Smith
 Carahsoft Technology Corp.
 11493 Sunset Hills Road
 Suite 100
 Reston, Virginia 20190

EMAIL: somari@city.jackson.ms.us

EMAIL: Garrett.Smith@carahsoft.com

PHONE: (601) 960-1084

PHONE: (571) 662-3062

FAX: (703) 871-8505

TERMS: National Cooperative Purchasing Alliance (NCPA)
 Contract Number: 01-86
 Term: Through November 30, 2023
 FTIN: 52-2189693
 Shipping Point: FOB Destination
 Credit Cards: VISA/MasterCard/AMEX
 Remit To: Same as Above
 Payment Terms: Net 30 (On Approved Credit)
 Cage Code: 1P3C5
 DUNS No: 088365767
 Sales Tax May Apply

QUOTE NO: 38770841
QUOTE DATE: 05/10/2023
QUOTE EXPIRES: 05/31/2023
RFQ NO:
SHIPPING: ESD
TOTAL PRICE: \$64,947.50

TOTAL QUOTE: \$64,947.50

LINE NO.	PART NO.	DESCRIPTION	QUOTE PRICE	SLG	QTY	EXTENDED PRICE
RECURRING ANNUAL FEE(S)						
1	PRE-B250500M-1-509	Grants Network Grantee Pre-Award - Between \$250-500 Million - Annual eCivis, Inc. - PRE-B250500M-1	\$17,412.50	SLG	1	\$17,412.50
2	POST-B250500M-1-509	Grants Network Grantee Post-Award - Between \$250-500 Million - Annual eCivis, Inc. - POST-B250500M-1	\$29,352.50	SLG	1	\$29,352.50
3	GN-USR-1-509	Grants Network - Users - Per User, Annual eCivis, Inc. - GN-USR-1	\$248.75	SLG	20	\$4,975.00
RECURRING ANNUAL FEE(S) SUBTOTAL:						\$51,740.00
NON-RECURRING ANNUAL FEE(S)						
4	EC-PM-1-509	eCivis - Implementation Services - Hourly Grants Network Grantee Full Implementation - Services eCivis, Inc. - EC-PM-1	\$248.75	SLG	56	\$13,930.00
5	EC-PM-1-509	eCivis - Implementation Services - Hourly Grants Network - Single Sign On - Services (optional) eCivis, Inc. - EC-PM-1	\$248.75	SLG	18	\$4,477.50
NON-RECURRING ANNUAL FEE(S) SUBTOTAL:						\$18,407.50
6	DISCOUNT	GTY Loyalty Discount eCivis, Inc. - Discount	-\$5,200.00	SLG	1	-\$5,200.00
SUBTOTAL:						-\$5,200.00
SUBTOTAL:						\$64,947.50

GOVERNMENT - PRICE QUOTATION

CARASOFT TECHNOLOGY CORP



11493 SUNSET HILLS ROAD | SUITE 100 | RESTON, VIRGINIA 20190
PHONE (703) 871-8500 | FAX (703) 871-8505 | TOLL FREE (888) 66CARAH
WWW.CARASOFT.COM | ECIVIS@CARASOFT.COM



LINE NO.	PART NO.	DESCRIPTION	QUOTE PRICE	QTY	EXTENDED PRICE
			TOTAL PRICE:		\$64,947.50
			TOTAL QUOTE:		\$64,947.50

Pricing valid through March 31st 2023
eCivis annual subscription is based on a 5-Year Term
eCivis will apply a 7% increase beginning in year 2

eCivis Annual fees
Year 1 is \$64,947.50
Year 2 is \$49,825.62
Year 3 is \$53,313.41
Year 4 is \$57,045.35
Year 5 is \$61,038.52
Total 5 year: \$286,170.40

Above pricing in US dollars
Applicable Taxes Extra
Pricing is not applicable in response to a formal RFP Process

Terms of Payment:

oSoftware:
100% upon Contract Effective Date (Net 30)
Year 2 due 365 days from Contract Effective Date and annually thereafter

Professional Services:
100% upon Contract Effective Date (Net 30)

Additional Professional Services are available upon request at eCivis's then current hourly rate, currently set at \$250/hr

Please include the following on your PO:

- PO made out to Carahsoft with our current address (11493 Sunset Hills Road, Suite 100, Reston, VA 20190)
- Payment terms: Net30
- Ship to and bill to address listed



City of Jackson Grants Management System

Statement of Work March 2, 2023

This information is confidential. Use of this information is strictly for the development and submission of a Statement of Work (SOW) by eCivis, Inc.

418 N. FAIR OAKS AVE. STE 301
PASADENA, CA 91103

ecivis.com
(877) 232 4847



Contents

1.0 PURPOSE	3
2.0 PROJECT OVERVIEW	3
3.0 City of Jackson RESPONSIBILITIES AND ASSUMPTIONS	3
4.0 SOFTWARE-AS-A-SERVICE / COMMERCIAL-OFF-THE-SHELF	5
5.0 PROJECT SCOPE	6
6.0 TASKS TO BE ACCOMPLISHED/FUNCTIONS TO BE PERFORMED	7
1.0 Preparation.....	7
2.0 Plan and Design.....	8
3.0 Configuration.....	8
4.0 User Acceptance Testing.....	8
5.0 Training.....	8
6.0 Go-Live	9
7.0 Products and Services	9
Implementation Overview	11
8.0 Out of Scope for this project	13
9.0 eCivis RESPONSIBILITIES	13
10.0 eCivis PROJECT MANAGEMENT CONTACTS	14
11.0 Project Schedule and Key Milestones	14
12.0 COST ASSUMPTIONS	14



1.0 PURPOSE

This Statement of Work (SOW) ensures expectations are documented and understood by all entities engaged in this project. The following sections include: project overview, responsibilities and assumptions, software-as-a-service/commercial-off-the-shelf, project scope, tasks to be accomplished/functions to be performed, products and services, out of scope for this project, eCivis responsibilities, eCivis project management contacts, project schedule and key milestones, and cost assumptions.

2.0 PROJECT OVERVIEW

To meet the goals of City of Jackson (City of Jackson), eCivis will rapidly deploy eCivis cloud-hosted, Commercial-off-the-shelf (COTS) Software-as-a-Service (SaaS) full lifecycle grants management system. eCivis will implement its proprietary grants management systems configured for City of Jackson authorized internal users to administer the grants management process and provide City of Jackson with direct management, accountability and oversight of federal funds in compliance with 2 CFR 200. eCivis will also include services for its solution with all relevant systems without impact to existing processes, developing, and providing appropriate comprehensive training of personnel, and all other applicable implementation and support services.

3.0 City of Jackson RESPONSIBILITIES AND ASSUMPTIONS

The projected deployment date and project implementation start date will be determined after a contract is executed after which City of Jackson can commit to the implementation schedule and the following responsibilities and assumptions:

1. City of Jackson shall provide a designated single point of contact for the duration of planning and implementation engagement.
2. City of Jackson shall engage in bi-weekly status meetings with eCivis to go over current progress, issues, resolutions, and other agenda.
3. City of Jackson shall provide all required data calls by the dates agreed upon in the project plan



Staffing

ROLE	RESPONSIBILITY	NAME, Title	Contact Information Mailing Address Email Telephone
GMS IMPLEMENTATION TEAM			
eCivis Project Manager	Responsible for planning, executing, monitoring, controlling, and closing the project. Responsible for the day-to-day management, coordination, planning, problem solving, and implementation of requirements to achieve task completion as presented in the Integrated Project Plan. Accountable for the project scope, project team, resources, and success of the project.		
eCivis Solution Architect	SME on GMS System, Responsible for System Configuration.		
eCivis Trainer	Responsible training, coordinating the training schedule, providing training materials.		
City of Jackson Grants Team Lead	Primary decision maker and contact for business requirements and deployment planning		
City of Jackson Grants Team SME	Review and approve business and systems configuration requirements		
City of Jackson PMO Project Manager	Co-responsibility for the Integrated GMS Project Plan and Reporting. Maintain SharePoint project page. Track and report budget status.		
SUPPORT POST-IMPLEMENTATION TEAM			
eCivis Executive Sponsor	Responsible for ensuring that the project's goals are aligned with the needs of the customer. Champions the project by gathering support, communicating goals, and overcoming resistance.		



ROLE	RESPONSIBILITY	NAME, Title	Contact Information Mailing Address Email Telephone
	Provide ongoing direction to the project team during a project's lifecycle.		
eCivis Sr. Customer Success Manager	Responsible for the ongoing user support and adoption of GMS.		
eCivis Customer Support Lead	Provide technical support to GMS users.		
City of Jackson Technical Support Manager	IT infrastructure support		
City of Jackson Application Support	IT application support		
City of Jackson Help Desk	Support GMS trouble management processes and application performance reporting.		

4.0 SOFTWARE-AS-A-SERVICE / COMMERCIAL-OFF-THE-SHELF

eCivis is a cloud-hosted, Commercial-off-the-shelf (COTS) SaaS grants management platform. The system is compatible with any hardware device that provides Internet access via a modern web browser and requires minimal internal IT support beyond the initial implementation.

eCivis is specifically built for managing the full grants management lifecycle and will standardize and streamline processes so that City of Jackson staff can save time, increase transparency, reduce redundancies, data entry, mitigate compliance risk, and improve organizational collaboration and knowledge.

eCivis provides ongoing innovation with continual updates, leading to:



- Consistently updated software features and functions.
- Improved data sharing with systems
- Uniform Grant Guidance training, indirect cost support and fund maximization, and access to additional learning resources
- Improved internal control and regulatory requirements compliance

5.0 PROJECT SCOPE

This project will implement eCivis' grants management solution for City of Jackson. The solution will be implemented across all applicable agencies and departments performing grant management functions. eCivis' project approach includes a Master Strategic Timeline that will be finalized upon contract execution.

The project approach is conducted in a hybrid waterfall agile phased-gate approach. A phased - gate approach allows for quick added software value, concurrent active phases, and early user adoption while ensuring critical dependencies are completed. The phases outlined below will support the Project Scope from initial Preparation to Full Product Adoption - Go Live. All Project Scope areas will be incorporated within the Strategic Timeline and will be discussed in more depth to address deliverables and descriptions.

eCivis proposes the following Statement of Work (SOW):

1. Preparation
 - a. Pre Kick Off Meeting
 - i. Review Project Plan Components
 - ii. Communicate Master Project TimeLine
 - iii. Provide Data Call forms
 - b. Project Kick Off Meeting
2. Plan and Design
 - a. Data Gathering
3. Configuration
 - a. Grantee Pre/Post-award management
4. User Acceptance Testing
 - a. Review all implementation components built, configured, migrated and imported during the build and configuration stage are delivered and operational.



5. Project Closeout
 - a. Remote training, training manuals and support
6. Go Live

6.0 TASKS TO BE ACCOMPLISHED/FUNCTIONS TO BE PERFORMED

During each phase, work proceeds in several areas and will be performed by both City of Jackson and eCivis.

1.0 Preparation

Task	Deliverable	Description
Preparation: Pre-Kickoff Meeting Tasks	Pre Kickoff Presentation Document	eCivis and City of Jackson to review master project timeline, scope of work and identify risks. <ul style="list-style-type: none"> • eCivis will email master project timeline to City of Jackson • eCivis will email pertinent eCivis staff contact information to City of Jackson. • eCivis will schedule required meetings with City of Jackson
	Master Project Timeline	
	All data call forms	eCivis will provide City of Jackson with the following data call forms which are due back to eCivis by the time agreed upon in the project timeline: <ul style="list-style-type: none"> ○ Add User/Department form (Excel Template) <p>eCivis will record Project Goals and Objectives determined during Pre Kick Off Meeting</p>
Project Kickoff Meeting	Project Kickoff Presentation Document	<ul style="list-style-type: none"> • Assemble Teams (eCivis and City of Jackson resources) • Conduct a formal Project Kick-Off meeting • Review Project Objectives and Master Project Timeline • Record Project Goals and Objectives determined during Kick Off Meeting



2.0 Plan and Design

Task	Deliverable	Description
Department Structure	City of Jackson to provide ALL completed data call forms to eCivis	City of Jackson staff has compiled and completed the following data call forms for eCivis to validate prior to configuration of their Grants Network account: <ul style="list-style-type: none"> User information and Department structure

3.0 Configuration

Task	Deliverable	Description
SSO Setup		<ul style="list-style-type: none"> Implement SSO setup
Configure		<ul style="list-style-type: none"> eCivis will load new users and configure the eCivis system

4.0 User Acceptance Testing

Task	Deliverable	Description
Validate imported data	Readiness Assessment	City of Jackson staff will review and validate all implementation components built, configured, migrated, and imported during the build and configuration stage are delivered and operational.

5.0 Training

Task	Deliverable	Description
User Training	<ul style="list-style-type: none"> Training Manuals, Virtual User Training Communicate ongoing 	eCivis will work with City of Jackson to complete the following initiatives: <ul style="list-style-type: none"> *Provide standard user guides and training resources Provide training for licensed users of Grants Network Ongoing support details



	support details	*City of Jackson will provide and maintain training resources unique to their specific use case and business processes.
--	-----------------	---

6.0 Go-Live

Task	Deliverable	Description
Go Live	Final Readiness Assessment	Go Live Success and Support Meeting – eCivis will continue to support City of Jackson

7.0 Products and Services

PRODUCT(S):

- Grantee Pre-Post Award

SERVICE: Single Sign On

eCivis supports Single Sign On (SSO) integration with Grants Network using popular identity providers. We partner with Auth0 to support a variety of enterprise connection types:

- OpenID Connect
- Microsoft® Active Directory™/LDAP
- Microsoft® Azure® AD™
- SAML (Service Provider Initiated)

This document has been assembled to provide an overview of the **SSO SAML integration** between a client's Azure Active Directory (AD) service and eCivis Grants Network™.



DESCRIPTION

Grants Network provides a username (email address) / password authentication scheme, standard across SaaS applications. When a client wants to control access to Grants Network within their domain eCivis permits Single Sign-On (SSO). This provides the following benefits:

1. The client is in control of eCivis access. When a user needs to be deactivated, this becomes a client Information Technology (IT) function.
2. The client sets the password policy, including complexity rules and refresh rate.
3. Client users only need to remember one set of credentials across the enterprise.

During setup, the eCivis Implementation team works with the client's IT department to define and configure their active directory implementation. This document covers Azure Active Directory authentication via Security Assertion Markup Language (SAML) 2.0.

The following configuration steps encompass the implementation:

1. eCivis Implementation works with the client to identify users and appropriate authorization levels.
2. eCivis provides the Client with an Identifier (Entity ID) and Reply URL (Assertion Consumer Service URL).
3. The Client IT creates a "Non-Gallery" enterprise application in their Azure AD organization. Upon request, the eCivis implementation team can provide an eCivis logo for the enterprise application.
4. The client adds authorized users to a security group associated with the enterprise application.
5. The Client IT configures SAML SSO for the new application using the details provided in step 2.
6. The Client IT sends the SAML Signing Certificate (Base64) and Login URL to eCivis.
7. The Client and eCivis Implementation Team verify setup and configuration.
8. The Client IT assigns additional users to the application, as needed, to allow access to Grants Network.



Implementation Overview

Azure AD Grants Network Enterprise Application Access SAML 2.0 Workflow

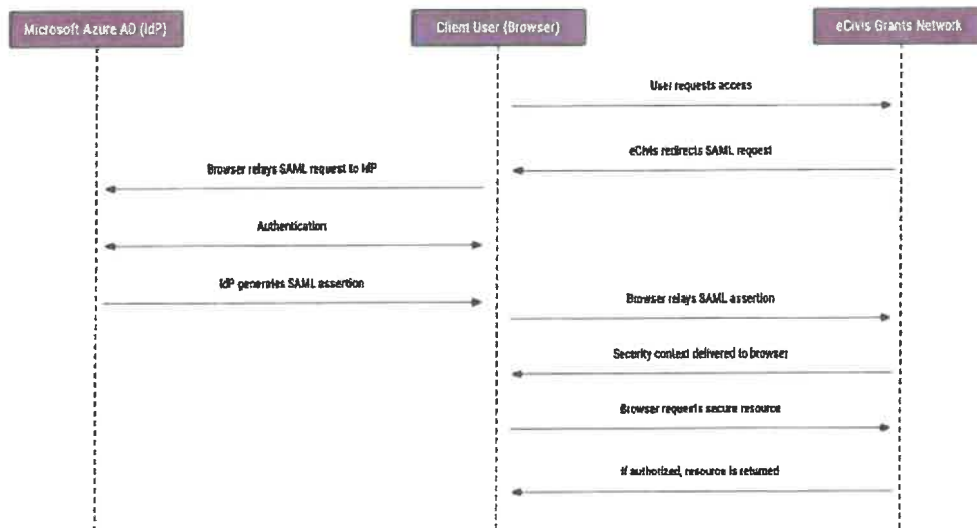

Client users will access Grants Network by visiting <https://qn.ecivis.com>. Based on their username, they will be redirected to the Microsoft IdP workflow. Once the user authenticates on Azure AD, Azure provides a SAML assertion that is passed along to eCivis Grants Network. Grants Network then authorizes the authenticated user providing the proper permissions as defined by the eCivis account setup team. The client user will now be granted access to eCivis Grants Network resources permitted by their access level.



The user experience mimics the following flow:

Azure AD - eCivis Grants Network Flow

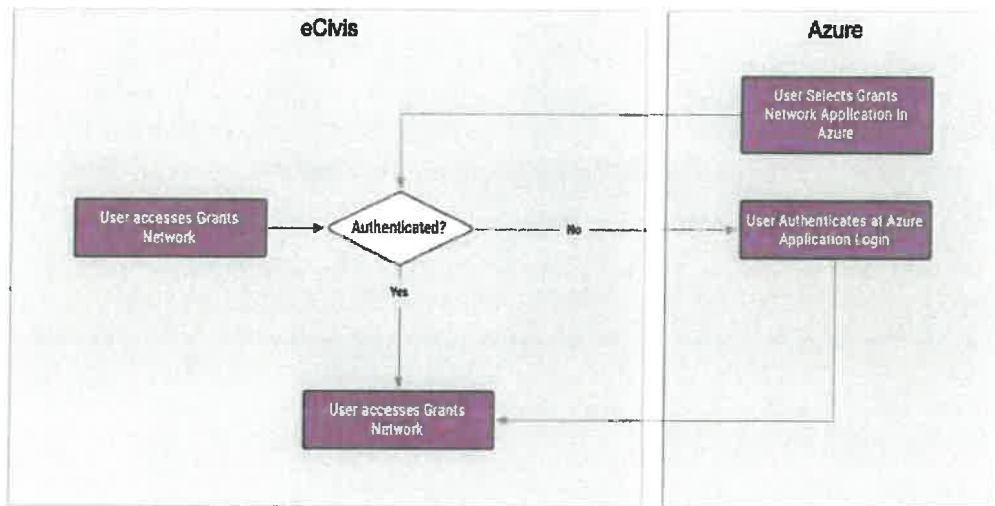



Reference Documentation

Add an unlisted (non-gallery) application to your Azure AD organization:

<https://docs.microsoft.com/en-us/azure/active-directory/manage-apps/add-non-gallery-app>

Configure SAML-based single sign-on to non-gallery applications:

<https://docs.microsoft.com/en-us/azure/active-directory/manage-apps/configure-single-sign-on-non-gallery-applications>

ASSUMPTIONS

1. The CLIENT has the internal expertise required to complete the process setup
2. The login will be directly at www.ecivis.com
3. SSO applies only to eCivis Grants network. Some administrative tools and external users will not be covered under the SSO process.

8.0 Out of Scope for this project

- Customizations or enhancements that are not mutually agreed upon by eCivis and City of Jackson in this statement of work.
- Historical award data
- System integrations that are not mutually agreed upon by eCivis and City of Jackson in this statement of work.
- Reporting integration outside of eCivis Grants Network

9.0 eCivis RESPONSIBILITIES

1. eCivis shall provide the following personnel

- Project Manager
- Implementation Specialist
- Customer Success Manager

2. eCivis will provide Master Project Timeline, and software user training resources.

3. eCivis shall provide Service Level Agreement (SLA), which will include:



- 99.9% monthly uptime.
- Single point of contact made via email or by calling a toll-free support number.
- Phone and email Technical Support Monday-Friday 8am-5pm ET
- Access to all patches (patches developed internally by ECivis to address core software issues like security, performance, etc.
- Access to new versions/upgrades
- Seamless modifications/enhancements per month

10.0 eCivis PROJECT MANAGEMENT CONTACTS

The eCivis' Project Manager and Customer Success Manager will be determined after contract execution.

11.0 Project Schedule and Key Milestones

Start date for the project will be influenced by the executed, signed contract. A detailed project plan will be developed after the project kick off meeting.

12.0 COST ASSUMPTIONS

Office of the City Attorney

455 East Capitol Street
Post Office Box 2779
Jackson, Mississippi 39207-2779
Telephone: (601) 960-1799
Facsimile: (601) 960-1756

OFFICE OF THE CITY ATTORNEY

This ORDER AUTHORIZING THE MAYOR TO EXECUTE AN AGREEMENT WITH eCIVIS, Inc FOR SERVICES RELATED TO THE IMPLEMENTATION OF A GRANTS NETWORK SYSTEM AND SUBSCRIPTION TO THE CLOUD HOSTED SaaS GRANTS MANAGEMENT PLATFORM is legally sufficient for placement in NOVUS Agenda.



Carrie Johnson, Deputy City Attorney

5/17/2023

Date

23

OFFICE OF THE CITY ATTORNEY
[Signature]

ORDER AUTHORIZING THE MAYOR TO EXECUTE A MEMORANDUM OF UNDERSTANDING WITH THE PRESIDENT AND FELLOWS OF HARVARD COLLEGE ACTING THROUGH THE TAUBMAN CENTER FOR STATE AND LOCAL GOVERNMENT AT THE HARVARD KENNEDY SCHOOL REGARDING THE GOVERNMENT INNOVATION FELLOW AND GOVERNMENT PERFORMANCE LAB

WHEREAS, the President and Fellows of Harvard College acting through the Taubman Center for State and Local Government at the Harvard Kennedy School ("Harvard") wishes to enter into a Memorandum of Understanding ("MOU") with the City of Jackson; and

WHEREAS, the terms of the MOU will determine the engagement and role of one or more Government Innovation Fellows and any other Harvard Kennedy School Government Performance Lab ("GPL") researchers, students, scholars and staff assisting the City in the development and implementation of Innovation Initiatives; and

WHEREAS, Innovation Initiatives may include improvements to procurement and contracting processes, use of data to inform service delivery and referral systems, piloting of new services or service-delivery models, establishing active contract management systems between governments and service providers, pay for success and performance-based contracts, optimizing resource allocation, and other initiatives designed to improve government performance and make government programs more effective; and

WHEREAS, the City shall have no responsibility for compensation or employment benefits for the Fellow(s), the GPL Director, or other members of the GPL Team with respect to any work done pursuant to this MOU; and

WHEREAS, the Fellows will not be treated as employees of the City, but shall be subject to all applicable City ethics and public records laws and guidelines and may be required to complete City training or other requirements applicable to the status of the Fellows; and

WHEREAS, the GPL Director, the Fellows, and other members of the GPL Team will have no authority to negotiate any agreements for the City, to incur any obligations or expenses on behalf of the City, or to act in any other manner on behalf of the City or in its name; and

WHEREAS, the term of the MOU is for twelve (12) months commencing on the effective date; and

WHEREAS, unless either party submits a notice of non-renewal at least thirty (30) days prior to the end of the twelve months, the MOU shall automatically renew for one (1) additional twelve month period and expire on the second anniversary of the effective date; and

OFFICE OF THE CITY ATTORNEY
[Handwritten Signature]

WHEREAS, further extension of the term will require written agreement of the parties:

WHEREAS, Harvard requires the City of Jackson to submit an executed Memorandum of Understanding and other documents in exchange for providing procurement and contracting assistance to the City of Jackson.

IT IS, THEREFORE, ORDERED that the Mayor is authorized to execute a Memorandum of Understanding with the Harvard and any other necessary documents associated with the MOU.

(LUMUMBA)

Memorandum of Understanding

This Memorandum of Understanding (“MOU”) is entered into as of [DATE] (the “Effective Date”) by and between President and Fellows of Harvard College acting through the Taubman Center for State and Local Government at the Harvard Kennedy School (“Harvard”) and the City of Jackson (the “City”), acting through the [Agency] (“Agency”).

The purposes of this MOU are (A) to state terms regarding the engagement and role of one or more Government Innovation Fellows (each a “Fellow”) and any other Harvard Kennedy School Government Performance Lab (“GPL”) researchers, students, scholars and staff who will assist the Agency in the development and implementation of Innovation Initiatives as described below; and (B) to set out other arrangements between the City and Harvard relating to the assistance the GPL Team, as described below, will be providing to the Agency with regards to the City's Innovation Initiatives.

The “GPL Team” means, collectively, persons from or affiliated with Harvard who participate in the activities under this MOU, including the Fellow(s), GPL managers, GPL Director, other researchers, students, scholars and staff affiliated with the GPL, and other Harvard researchers participating in the activities under this MOU.

“Innovation Initiatives” may include improvements to procurement and contracting processes, use of data to inform service delivery and referral systems, piloting of new services or service-delivery models, establishing active contract management systems between governments and service providers, pay for success and performance-based contracts, optimizing resource allocation, and other initiatives designed to improve government performance and make government programs more effective.

The parties agree as follows:

1. Responsibilities of Fellow(s). The Fellow(s) will work with an Agency team in connection with Agency’s analysis of and process for implementation of Innovation Initiatives. The Fellows’ responsibilities may include general support for the Agency team in designing and implementing Innovation Initiatives, including supporting data collection and analysis; aiding preparation of briefing papers, reports, and procurement documents; and assisting in engagement of internal and external stakeholders as appropriate. The Fellow(s) and the other members of the GPL Team will not provide, and

are not engaged or authorized by the City to provide, legal advice or services, notwithstanding that one or more may be trained as lawyers.

2. Supervision. [[Name of advisor]/ A senior advisor at Agency as designated by the Agency] will serve as the Agency's key point of contact with the Fellow and is responsible for advancing Innovation Initiatives for Agency.
3. No Salary and Benefits The City shall have no responsibility for compensation or employment benefits for the Fellow(s), the GPL Director, or other members of the GPL Team with respect to any work done pursuant to this MOU.
4. Status of Fellow(s). The Fellow(s) will not be treated as an employee of the City, but shall be subject to all applicable City ethics and public records laws and guidelines. The Fellow(s) may be required to complete City training or other requirements applicable to the status of the Fellow(s).
5. Other Support. Agency agrees that, if Agency incorporates the advice of the GPL Team in an Innovation Initiative contract between the City and a third party, or if the GPL Team, at the request of the Agency, communicates on the City's behalf with that third party about the Innovation Initiative, said Innovation Initiative contract will include as a contract term a limitation of liability of Harvard and the GPL Team to the same effect as is set out in the Limitation of Liability Section of this MOU. The GPL Team may also, at its discretion and as a condition of providing services relating to said contract or said third party, require the third party to agree to such limitation of liability in a separate contract with Harvard.
6. Confidential Information.
 - a. In order to engage in activities under this MOU, the GPL Team will need to participate in internal discussions among City employees and view internal City documents and written communications exempt from disclosure under the [City's Freedom of Information Act or corresponding regulation] pertaining to the Innovation Initiatives and the GPL Team's activities. For purposes of this MOU, "Confidential Information" shall mean any information from discussions, internal documents, and written communications disclosed by the Agency, whether orally or in writing, to the GPL Team that either has been marked by the City as "Confidential or that the GPL Team knows or should reasonably know that the Agency considers to be confidential, under the circumstances. "

- b. Non Disclosure of Confidential Information. Except as provided in the paragraph immediately below, the GPL Team shall (i) hold the Confidential Information in confidence, and (ii) not at any time divulge, disclose, or communicate the Confidential Information to anyone other than City employees except as authorized by Agency, or use the Confidential Information for any purpose other than in connection with this MOU. The GPL Team will protect the Confidential Information by using the same degree of care, but no less than a reasonable degree of care, to prevent unauthorized disclosure or publication of the Confidential Information as the GPL Team uses to protect Harvard's confidential information of a like nature.
- c. Other Disclosure Provisions. The limitations on disclosure set forth above do not apply with respect to the Confidential Information that (a) was in the GPL Team's possession before the Effective Date; (b) is or becomes a matter of public knowledge or publicly available other than through breach of this Confidential Information Section by the GPL Team; or (c) is disclosed by the GPL Team with the prior written approval of a duly authorized representative of the City. In addition, the GPL Team may disclose Confidential Information if such disclosure is required by any law, rule, regulation or judicial or administrative process, provided that, if permitted by applicable law or regulation, the GPL Team shall notify Agency prior to any such required disclosure.
7. Avoiding Conflicts of Interest. Members of the GPL Team will not, at any time during the term of the MOU, provide services to vendors or service providers in connection with transactions or proposed transactions with the City relating to the financing or implementation by the City of Innovation Initiatives that the GPL Team advised on or assisted in developing. Members of the GPL Team may at any time work with and advise other states, counties, municipalities or government agencies that are undertaking similar Innovation Initiatives, including other jurisdictions that may be applying for the same federal grants that the City may be applying for. Members of the GPL Team may also advise the U.S. federal government and governments in other countries on strategies to advance similar Innovation Initiatives.
8. No Authority. The GPL Director, the Fellow(s) and other members of the GPL Team will have no authority to negotiate any agreements for the City, to incur any obligations or expenses on behalf of the City, or to act in any other manner on behalf of the City or in its name.

9. Limitation of Liability. The City acknowledges that performance of the work described in this MOU will involve the expression of professional ideas, judgments and opinions by the GPL Team, and that it is in the City's interest to have such ideas, judgments and opinions expressed frankly, without concern on the part of the GPL Team or Harvard that such ideas, judgments and opinions will be deemed representations, warranties or covenants upon which the City may claim reliance. The City further acknowledges that the Innovation Initiatives are relatively new, little-used and little-studied tools. Accordingly, the City understands and agrees that the GPL Team and Harvard do not and will not make any warranties or representations of any kind, express or implied, concerning the accuracy of ideas, judgments, opinions, recommendations, projections, analyses or estimates which any member of the GPL Team provides to the City under this MOU (collectively, "Contributions"). The City further agrees that (i) any decision the City may make to rely on any Contributions shall be at its own risk; and (ii) neither Harvard nor any member of the GPL Team shall be liable to the City for, and the City shall not make any claim against Harvard or any member of the GPL Team relating to, any claims, liabilities, losses, damages, costs or expenses of any kind (including attorneys' fees) which the City may at any time sustain or incur in connection with or arising out of any Contributions or the City's reliance thereon or use thereof, other than claims, liabilities, losses, damages, costs and expenses resulting from the gross negligence or intentional misconduct of any member of the GPL Team. Without limiting the foregoing, in no event shall Harvard or any member of the GPL Team be liable for any indirect, consequential, exemplary or punitive damages whatsoever in connection with claims arising under or relating to this MOU, whether based upon a claim or action of contract, warranty, negligence, strict liability, or any other legal theory or cause of action, even if advised of the possibility of such damages.

10. Intellectual Property and Publication Rights

a. Work Product and Harvard Created Materials.

- i. The term Work Product as used herein comprises works subject to copyright, including materials, notes, designs, technical data, methodologies and know-how, research findings, reports, documentation, and other similar work product in any media or formats.
- ii. The City shall retain sole ownership of all rights, title, and interest, including all copyrights and other intellectual property rights, in and to Work Product developed or acquired by the City or on the City's behalf

either prior to this MOU or under this MOU without the participation of the GPL Team.

- iii. Harvard shall be the sole owner of all rights, title, and interest, including all copyrights and other intellectual property rights, in and to the Work Product conceived, created or provided by Harvard or the GPL Team under this MOU ("Harvard Created Materials"), whether alone or with any contribution from the City or its personnel. To the extent the City or its personnel may acquire any right or interest in such Work Product by operation of law, the City hereby irrevocably assigns all such right and interest exclusively to Harvard.
 - iv. In connection with the City's pursuit of its public purpose, Harvard hereby grants to the City a fully-paid, royalty-free, non-exclusive, worldwide, irrevocable, perpetual, license to use, reproduce, distribute, modify, and transmit the Harvard Created Materials in any media now known or hereafter developed.
 - v. The City understands and accepts that Harvard intends to share Harvard Created Materials and related analytic concepts and tools with other jurisdictions in connection with their Innovation Initiatives.
- b. Publication Rights. In addition to providing assistance and support to the City, a main purpose of this MOU for Harvard is as an opportunity to research, study, learn more about and make publicly known the design and implementation of Innovation Initiatives. Accordingly, Harvard and any member of the GPL Team shall have the right to use, publish, and present publicly any findings, analyses, data and opinions based on or derived from Harvard Created Materials, from Contributions or from other work performed under this MOU; provided that no Confidential Information shall be disclosed in such publications or presentations. The GPL Team shall provide Agency with an opportunity to review any such materials at least 30 days prior to submission for publication or presentation solely for the purpose of identifying any Confidential Information that is contained therein and should be removed; Agency shall perform such review within 30 days of receipt. Publications and presentations of general conclusions and analyses drawn from work with multiple jurisdictions and publications and presentations that summarize publicly available information about the City's initiatives do not have to be submitted for review.

11. Term and Termination.

- a. The term of this MOU is twelve months commencing on the Effective Date. Unless either party submits a notice of non-renewal at least 30 days prior to the end of the twelve months, this MOU shall be automatically renewed for one (1) additional twelve months period and expire on the second anniversary of the Effective Date. Further extensions of the term will require written agreement of the Parties.
- b. Either Party may terminate this MOU upon 30 days' written notice to the other Party.
- c. The provisions of this MOU concerning confidential information, limitation of liability, intellectual property and publication rights, and publicity and use of names shall survive expiration or termination of this MOU.

12. Publicity and Use of Names. Neither party may issue a press release or other public announcement about this MOU, nor may it use any name, trademark or insignia of the other party (or of any school, department or unit of the other party) for promotional purposes or any other public purposes in connection with this MOU, without the prior written approval of the other party. Without limiting the foregoing, neither party shall in any manner suggest that its programs, findings or publications have been endorsed by the other party. However, each party may identify the other in any description of the MOU in its customary listings of activities; Harvard and the GPL Team may identify the City and the Agency in publications about the Innovation Initiatives as described in Section 10(b); and the GPL may state on its website that it is assisting the City.

13. Other Provisions.

- a. Governing Law. This MOU shall be governed by and interpreted in accordance with the laws of the City of Jackson (excluding conflict of laws rules).
- b. Severability. In the event that any provision or section of this MOU shall be held to be invalid by any court, such holding shall not affect in any respect whatsoever the validity of the remainder of the MOU unless the invalid provision materially affects the rights of the parties.
- c. Notices. Any notice under this MOU may be given in person, or sent by fax, by electronic mail, by registered or certified mail, postage prepaid, or by recognized delivery service, to a party's address given from time to time by such notice, and

such notice shall be deemed to have been given when so delivered, sent by fax or electronic mail, or mailed.

- d. Force Majeure. Neither party shall be liable for any delays or failures in performance due to circumstances beyond the party's reasonable control.
- e. Entire Agreement; Amendment. This MOU constitutes the entire agreement between the parties with respect to the Innovation Initiatives which are the subject matter hereof, and supersedes all prior or contemporaneous agreements concerning such matters. This MOU may not be amended or modified except with the written consent of both parties.

Executed as of the Effective Date.

For the City of Jackson, acting through the [Agency]

For President and Fellows of Harvard College, acting through the Taubman Center for State and Local Government at the Harvard Kennedy School

By: _____

By: _____

Name: _____

Name: Matthew Alper

Title: _____

Title: Senior Associate Dean for Research Policy and Administration, HKS

Office of the City Attorney

455 East Capitol Street
Post Office Box 2779
Jackson, Mississippi 39207-2779
Telephone: (601) 960-1799
Facsimile: (601) 960-1756

OFFICE OF THE CITY ATTORNEY

This ORDER AUTHORIZING THE MAYOR TO EXECUTE A MEMORANDUM OF UNDERSTANDING WITH THE PRESIDENT AND FELLOWS OF HARVARD COLLEGE ACTING THROUGH THE TAUBMAN CENTER FOR STATE AND LOCAL GOVERNMENT AT THE HARVARD KENNEDY SCHOOL REGARDING THE GOVERNMENT INNOVATION FELLOW AND GOVERNMENT PERFORMANCE LAB is legally sufficient for placement in NOVUS Agenda.



Carrie Johnson, Deputy City Attorney

5/17/2023

Date

24

ORDER REVISING THE FISCAL YEAR 2023 MUNICIPAL BUDGET FOR THE CITY OF JACKSON POLICE DEPARTMENT

OFFICE OF THE CITY ATTORNEY
MAY 23 2023

WHEREAS, Section 21-35-25 of the Mississippi Code authorizes the governing authorities of a municipality to transfer at any time during the fiscal year sums remaining and not needed in any fund or account to funds or accounts where needed by order to such effect entered upon their minutes; and

WHEREAS, the Jackson Police Department has identified funds in the amount of \$1,625,000 in the budgeted salaries account, which will not be expended because of a reduction in overtime expenditures; and

WHEREAS, the unexpended funds are needed to purchase Police Fleet Vehicles, Fleet Emergency Equipment, and repairs to the Public Safety Communications Building for the continued operation of answering 911 calls for service.

WHEREAS, separate amendments to an originally adopted budget during one fiscal year which affect a particular department fund shall be considered as one (1) amendment in determining whether the ten percent (10%) threshold requiring publication or posting has been reached; and

WHEREAS, the Jackson Police Department believes that revising its budget to transfer funds from the budgeted salaries account to other accounts to be used as stated promotes and serves public safety interests; and

WHEREAS, the Jackson Police Department recommends that its fiscal year 2022 - 2023 budget be revised as follows:

WHEREAS, the Department of Administration has assessed the proposed amendment and determined that the revision does not exceed ten percent (10%) of the total amount appropriated and authorized to be expended in a particular fund or account and will not require publication.

IT IS HEREBY ORDERED that the Jackson Police Department's fiscal year 2022 - 2023 budget may be revised as set forth in this order.

IT IS HEREBY ORDERED the provisions of this order shall not be construed as negating the procurement requirements set forth in the state purchasing laws.

Transfer From Account and Amounts

Transfer to Accounts and Amount

001.44220.6111 - \$250,000
001.44221.6111 - \$75,000
001.44235.6111 - \$100,000
001.44240.6111 - \$200,000
001.44240.6114 - \$1,000,000

001.44240.6855 - \$225,000
001.44240.6868 - \$1,000,000
001.44221.6824 - \$400,000

Total: \$1,625,000

Total: \$1,625,000

APPROVED FOR AGENDA:

NO. 24
Agenda Date May 23, 2023
Agenda Item # _____
By: DAVIS, LUMUMBA

CITY COUNCIL AGENDA ITEM 10 POINT DATA SHEET

May 1, 2023
DATE

POINTS	COMMENTS																																													
1. Brief Description/Purpose	ORDER REVISING THE FISCAL YEAR 2023 MUNICIPAL BUDGET FOR THE CITY OF JACKSON POLICE DEPARTMENT																																													
2. Public Policy Initiative 1. Youth & Education 2. Crime Prevention 3. Changes in City Government 4. Neighborhood Enhancement 5. Economic Development 6. Infrastructure and Transportation 7. Quality of Life	2. CRIME PREVENTION 3. CHANGES IN CITY GOVERNMENT 4. NEIGHBORHOOD ENHANCEMENT 5. QUALITY OF LIFE																																													
3. Who will be affected	JACKSON POLICE DEPARTMENT																																													
4. Benefits	TO PROVIDE VEHICLES FOR POLICE PERSONNEL, MAKE NEEDED REPAIRS TO THE PUBLIC SAFETY COMMUNICATIONS BUILDING																																													
5. Schedule (beginning date)	UPON COUNCIL APPROVAL																																													
6. Location: ▪ WARD ▪ CITYWIDE (yes or no) (area) ▪ Project limits if applicable	ALL WARDS CITYWIDE N/A																																													
7. Action implemented by: ▪ City Department ▪ Consultant	JACKSON POLICE DEPARTMENT																																													
8. COST	\$1,625,000																																													
9. Source of Funding ▪ General Fund X ▪ Grant ▪ Bond ▪ Other	Transfer From 00144220 6111 - \$250,000 00144221 6111 - \$75,000 00144235 6111 - \$100,000 00144240 6111 - \$200,000 00144240 6114 - \$1,000,000 Transfer To 00144240 6855 - \$225,000 (Fleet Upfitting) 00144240 6868 - \$1,000,000 (Fleet Purchases) 00144235 6317 - \$400,000 (Building Repairs)																																													
10. EBO participation	<table border="0"> <tr> <td>ABE</td> <td>_____ %</td> <td>WAIVER</td> <td>yes</td> <td>_____</td> <td>no</td> <td>_____</td> <td>N/A</td> <td>_____</td> </tr> <tr> <td>AABE</td> <td>_____ %</td> <td>WAIVER</td> <td>yes</td> <td>_____</td> <td>no</td> <td>_____</td> <td>N/A</td> <td>_____</td> </tr> <tr> <td>WBE</td> <td>_____ %</td> <td>WAIVER</td> <td>yes</td> <td>_____</td> <td>no</td> <td>_____</td> <td>N/A</td> <td>_____</td> </tr> <tr> <td>HBE</td> <td>_____ %</td> <td>WAIVER</td> <td>yes</td> <td>_____</td> <td>no</td> <td>_____</td> <td>N/A</td> <td>_____</td> </tr> <tr> <td>NABE</td> <td>_____ %</td> <td>WAIVER</td> <td>yes</td> <td>_____</td> <td>no</td> <td>_____</td> <td>N/A</td> <td>_____</td> </tr> </table>	ABE	_____ %	WAIVER	yes	_____	no	_____	N/A	_____	AABE	_____ %	WAIVER	yes	_____	no	_____	N/A	_____	WBE	_____ %	WAIVER	yes	_____	no	_____	N/A	_____	HBE	_____ %	WAIVER	yes	_____	no	_____	N/A	_____	NABE	_____ %	WAIVER	yes	_____	no	_____	N/A	_____
ABE	_____ %	WAIVER	yes	_____	no	_____	N/A	_____																																						
AABE	_____ %	WAIVER	yes	_____	no	_____	N/A	_____																																						
WBE	_____ %	WAIVER	yes	_____	no	_____	N/A	_____																																						
HBE	_____ %	WAIVER	yes	_____	no	_____	N/A	_____																																						
NABE	_____ %	WAIVER	yes	_____	no	_____	N/A	_____																																						



Chief of Police
James E. Davis

JACKSON POLICE DEPARTMENT
Office of the Chief of Police

Assistant Chief of Police
Joseph Wade

Memorandum

To: Chokwe Antar Lumumba, Mayor, City of Jackson

From: James E. Davis, Chief of Police, Jackson Police Department

JED 5/3/23

Date: Wednesday, May 3, 2023

Re: Order Revising Fiscal Year 2023 Municipal Budget for the Jackson Police Department

It is recommended that the Order revising the Fiscal Year 2023 Municipal Budget for the city of Jackson Police Department be approved. The funds are currently available due to a reduction in overtime expenditure. In addition, the funds are needed to purchase emergency vehicles for the police department and make needed repairs to the Public Safety Communications building. Therefore, I am requesting budget revisions to fund these expenditures.

If you have any questions or need additional information, please contact me.

Office of the City Attorney

455 East Capitol Street
Post Office Box 2779
Jackson, Mississippi 39207-2779
Telephone: (601) 960-1799
Facsimile: (601) 960-1756

OFFICE OF THE CITY ATTORNEY

This **ORDER REVISING THE FISCAL YEAR 2022-2023 BUDGET OF THE JACKSON POLICE DEPARTMENT (\$1,625,000)** is legally sufficient for placement in NOVUS Agenda.



Catoria Martin

5/14/23
Date

Carrie Johnson, Sr. Deputy City Attorney

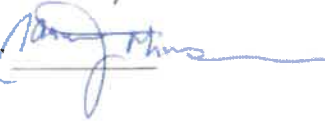

OFFICE OF THE CITY ATTORNEY

25

ORDER ACCEPTING THE BID OF ACTIVE SOLUTIONS, LLC FOR A THIRTY-SIX (36) MONTH SUPPLY OF SAFECITYCAM SURVEILLANCE CAMERAS AND INSTALLATION AND AUTHORIZING THE MAYOR TO EXECUTE A SALES AGREEMENT BETWEEN THE CITY OF JACKSON AND ACTIVE SOLUTIONS, LLC

OFFICE OF THE CITY ATTORNEY
5/23/23
J.M.

WHEREAS, on March 21, 2023, the City of Jackson, Mississippi, received and opened one (1) sealed proposal in response to RFP No. 84084-032123 thirty-six (36) month term for SAFECITYCAM surveillance cameras and installation; and

WHEREAS, the Jackson Police Department reviewed the proposal submitted by Active Solutions, LLC, and the department determined that Active Solutions, LLC, with its principal office at 1215 Prytania Street, Suite 301, New Orleans, Louisiana 70130, submitted the lowest and best bid; and

WHEREAS, the Jackson Police Department recommends that the governing authorities for the City of Jackson accept Active Solutions, LLC's bid in the amount of \$6,839.42 per camera unit and installation. If cameras are installed on Entergy poles, there will be an additional charge for rights to use the Entergy Poles (Entergy Pole Fee-\$250.00, Entergy Approved Disconnect w/Power Shut Off - \$532.50, and additional charges will be billed for alternative data backhaul methods, if required); and

WHEREAS, the Jackson Police Department also recommends that the Jackson City Council authorize the Mayor to execute a Sales Agreement between the City of Jackson and Active Solutions, LLC, a copy of which is attached to this Order and made part of these minutes.

IT IS HEREBY ORDERED that the bid submitted by Active Solutions, LLC is the lowest and best bid and is hereby accepted by the governing authorities for the City of Jackson.

IT IS FURTHER ORDERED the Mayor is authorized to execute the Sales Agreement with Active Solutions, LLC. to provide 36 Months Term SAFECITYCAM Video Surveillance Cameras and Installation on behalf of the City of Jackson Police Department and to make any and all payments for said SAFECITYCAM Video Surveillance Cameras and Installation from General Funds.

MO: tm 04/05/2023

BY: DAVIS, JIMERSON, LUMUMBA

Agenda Item No. 25
May 23, 2023

Sales Agreement

For City of Jackson RFP No. 84084-032123

This Sales Agreement (the "Agreement") dated this _____ day of _____, _____ between:

Active Solutions, LLC

of 1215 Prytania Street, Suite 301, New Orleans, Louisiana 70130 (the "Seller")

And

City of Jackson, Mississippi

of 219 South President Street, Jackson, Mississippi 39201 (the "Buyer")

Recitals

WHEREAS, Active Solutions, LLC is the winner of the public bid by City of Jackson, MS, RFP No. 84084-032123 36 Month Term for SAFECITYCAM Surveillance Cameras and Installation of March 21, 2023;

WHEREAS, Active Solutions, LLC is the manufacturer and distributor of all SAFECITYCAM brand products in the United States;

WHEREAS, Active Solutions, LLC assists law enforcement agencies in Mississippi by providing a cost-effective, east-to-install solution providing broad coverage with SAFECITYCAM's;

WHEREAS, the SAFECITYCAM enclosures have highly visible strobe lights that are used for deterrent effect and to symbolize the City of Jackson's commitment to the safety and security of the public;

WHEREAS, the City of Jackson now desires Active Solutions, LLC to provide multiple SAFECITYCAMs for installation throughout the City to support the Jackson Police Department with citywide video surveillance to observe and intervene from any remote location.

NOW, THEREFORE, in consideration of the covenants and Agreements contained and this Sales Agreement the parties to this Agreement agree as follows:

Agreement

Sale of Goods

1. Per the RFP Specification, Seller will sell, transfer, and deliver to the Buyer the following Goods for each camera and its' installation:
 - A. Active Solutions SAFECITYCAM with Camera
 - B. Depending on the camera installation site, there may be additional fees to be borne by City for use of Entergy poles or alternative data backhaul which will be billed upon completion of the camera installation(s).
2. The Seller will provide the following services to the Buyer:
 - A. Seller will provide installation services to Buyer for each camera unit at locations to be determined by Buyer. Upon installation of the cameras, Seller will verify units are communicating with the City of Jackson Real Time Command Center video platform.

- B. During the life of this Sales Agreement, the Seller will provide the Buyer with the ability to report technical issues 24 x 7.

Purchase Price

3. The Buyer will accept the Goods and pay for the Goods for the sum of \$6,839.42 (USD) (the "purchase price") per camera per the RFP Specification and Pricing for the camera and its' installation to be paid upon the completion of each phase as enunciated and required in Clause Six of this Agreement.
 - a. Cameras are usually ordered and installed in batches, payment for these cameras in batches is accepted by both parties for ease of a payment schedule.
 - b. Invoices that become past due after ~~thirty days~~ forty-five days of an Invoice submission will incur a ~~40%~~ 1 ½% late fee per month on a cumulative basis for every month said invoice(s) are outstanding.
4. Service Plan – Seller includes in this Agreement a preventative maintenance plan which includes quarterly site visits/inspections to the camera locations. Any additional service or maintenance desired will be the subject of a separate Service Agreement.
5. The Seller and the Buyer both acknowledge the sufficiency of this consideration.

Additional Charges

6. The Purchase Price of \$6,839.42 does not include any additional charges that may arise for camera installations outside of the camera unit price which includes the cost of installation labor. If cameras are to be installed on Entergy poles, there will be additional charges (below) for rights to use the Entergy poles.
 - a. Entergy Pole Fee - \$250.00 One-time fee
 - b. Entergy Approved Disconnect with Power Shut Off - \$532.50
 - c. If alternative data backhaul methods are required, any additional charges will be billed with final invoicing.
 - d. All additional charges will be included with the Final Invoice to the Buyer.

Payment

7. The Purchase Price and any additional charges will be paid upon installation of the cameras and within thirty (30) days but no later than forty five (45) days of invoicing.
 - A. Invoices that become past due after forty five (45) days of an Invoice submission will incur a 1 ½% late fee per month on a cumulative basis for every month said invoice(s) are outstanding. If after ninety (90) days, full payment of Invoice(s) and any interest owed has not been received by Seller, Seller reserves the right to repossess any/all equipment/hardware made the subject of said Invoice.
 - B. In the case of camera orders that are awaiting installation, invoicing will occur within ninety days of the notice to Buyer that cameras are ready for installation and payment will be required regardless of their being installed. Under these conditions, cameras will be delivered to Buyer for receipt and storage.

Term

8. The term of this Sales Agreement shall commence on the date of the last signature and continue in full effect for three years after the date of the last signature. Unless terminated in accordance with Section

24 below, this Agreement will automatically renew upon the expiration of the three (3) year term, which is subject to the prior approval by the governing authorities for the City of Jackson

9. Note: All installation work to be completed within one (1) year, at most, of receipt of any single Purchase Order from City with considerations for weather related delays or other delays encountered.

Default

10. Notwithstanding anything to the contrary in this Agreement, if the Buyer defaults in the performance of any obligation under this Agreement, then the Seller may declare the entire Purchase Price owing under this Agreement at that time to be immediately due and payable.

Delivery of Goods

11. The Goods will be deemed received by the Buyer when delivered to the Buyer at 327 E Pascagoula St, Jackson, Mississippi 39205 or at the designated installation sites selected by Buyer. The method of shipment will be within the discretion of the Seller.
 - A. Product orders will be considered initiated with the issuance and receipt of a Purchase Order or other written order from Buyer. Due to the sophistication and custom-built nature of the camera units being purchased, all Purchase Orders will remain open and viable for a period of one (1) year from the date of the Purchase Order.

Risk of Loss

12. The risk of loss from any casualty to the Goods, regardless of the cause, will be on the Seller until the Goods have been received by the Buyer.

Warranties

13. The Seller warrants that: (1) the Seller is the legal owner of the Goods; (2) the Seller has the right to sell the Goods, and (3) the Seller will warrant and defend the title of the Goods against any and all claims and demands of all persons.
14. The Seller warrants that the Goods will be fit for the purpose for which such Goods are ordinarily intended.
15. The Buyer has been given the opportunity to inspect the Goods or to have it inspected and the Buyer has accepted the Goods in its existing condition.

Title

16. Title to the Goods will remain with the Seller until delivery and actual receipt of the Goods by the Buyer and in such time as payment is received. In the alternative, if the Seller delivers a document of title or registrable bill of sale of the Goods, bearing any necessary endorsement, to the Buyer.

Security Interest

17. The Seller retains a security interest in the Goods until paid in full.

Inspection

18. Inspection will be made by the Buyer at the time and place of delivery.

19. Any refund will not include the cost of delivery or installation. Those cost will be borne by the Buyer.

Claims

20. The Buyers failure to give notice of any claim within 30 days from the date of delivery will constitute an unqualified acceptance of the Goods and a waiver by the Buyer of all claims with respect to the Goods.

Excuse for Delay or Failure to Perform

21. The Seller will not be liable in any way for any delay, non-delivery or default and shipment due to labor disputes, transportation shortage, delays and receipt of materials, priorities, fires, accidents, and other causes beyond the control of the Seller or its suppliers. If the Seller, in it's sole judgment, will be prevented directly or indirectly, on account of any cause beyond its control, from delivering the Goods at the time specified or within one month after the date of this Agreement, then the Seller will have the right terminate this Agreement by notice in writing to the Buyer, which notice will be accompanied by full refund of all sums paid by the Buyer pursuant to this Agreement.

Cancellation

22. The Seller reserves the right to cancel this Agreement:
 - A. If the Buyer fails to pay for any shipment when due;
 - B. In the event of the Buyers insolvency or bankruptcy, or
 - C. If the Seller deems that its prospective payment is impaired.

Notices

23. Any notice to be given or document to be delivered to either the Seller or Buyer pursuant to this Agreement will be sufficient if delivered personally or sent by prepaid registered mail to the address specified below. Any written notice or delivery of documents will have been given, made and received on the day of delivery, if delivered personally, or on the third (3rd) consecutive business day next following the date of mailing if sent by prepaid registered mail.

Additional Provisions

24. If either Party desires to discontinue any Services under this Agreement prior to the expiration of the three (3) year term, the Party may do so by providing written notice of termination of the particular Services being terminated which shall become effective thirty (30) days from documented receipt of said notice.
25. Buyer hereby asserts that it is exempt from the payment of taxes that might be applicable to the Services procured hereunder.
26. It is understood that this Agreement requires approval by the governing authorities of the City of Jackson and if this Agreement is not approved by the governing authorities, this Agreement is void and no payment shall be made hereunder.

27. It is expressly understood and agreed that the obligation of the City of Jackson to proceed under this Agreement is conditioned upon the appropriation of funds by the City Council and the receipt of funds. If the funds anticipated for the continuing fulfillment of the Agreement are, at any time, not forthcoming or insufficient, either through the failure of the governing authorities to provide funds or of the governing authorities to appropriate funds or the discontinuance or material alteration of the program under which funds were provided or if funds are not otherwise available to the City of Jackson, the Buyer shall have the right upon ten (10) working days written notice to the Seller to terminate this Agreement without damage, penalty, cost or expenses to the Buyer of any kind whatsoever, other than payment for legal services rendered prior to receiving written notice. The effective date of termination shall be as specified in the notice of termination. Any orders for cameras already submitted will be billed and payable within thirty (30) days regardless of funding alterations by Buyer.
28. Neither Party shall be held liable for any damages or penalty for delay in the performance of its obligations hereunder when such delay is due to earthquake, flood, fire, hurricane, power failure, tornado, terror, riot, war, or other event or disaster beyond the Party's control, provided the Party uses reasonable efforts seeking to (a) mitigate the consequences and (b) promptly notify the other Party.
29. This Agreement shall not be construed as creating an agency, partnership, joint venture, or any other form of legal association between the Parties and each Party is an independent contractor.
30. Each Party agrees that during the term of this Agreement and for a period of two years after its expiration or termination, neither Party will solicit or encourage any employee or consultant to discontinue their employment or engagement with the other Party. This provision shall not apply to employment opportunities of either Party advertised to the general public (e.g., newspaper advertisement, internet advertisement or listing, etc.) to which an employee of either Party may respond.
31. The Seller shall maintain all financial and programmatic records, documents and other evidence related to the expenditure of funds for camera builds and installations for this Agreement for a minimum of three (3) years.
32. This Agreement, including any accompanying exhibits, attachments, and appendices, is subject to the "Mississippi Public Records Act of 1983," and its exceptions. See Mississippi Code Annotated §§ 25-61-1 *et seq.* and Mississippi Code Annotated § 79-23-1.
33. The Seller agrees to indemnify and hold harmless the City, its officers, and its employees from any act of or omission of the Agency, its employees, agency, or servants, that results in the bodily injury, property damage, death of any party, or any other claims for physical damages growing out the performance of this Agreement.

General Provisions

34. Headings are inserted for convenience only and are not to be considered when interpreting this Agreement. Words in the singular mean and include the plural and vice versa. Words in the masculine mean and include the feminine and vice versa.
35. All representations and warranties of the Seller contained in this Agreement will survive the closing of this Agreement.

36. The Buyer may not assign its rights or delegate its performance under this Agreement without the prior written consent of the Seller, and any attempted assignment or delegation without such consent will be void. And assignment would change the duty imposed by this Agreement, would increase the burden or risk involved and would impair the chance of obtaining performance or payment.
37. This Agreement cannot be modified in any way except in writing signed by all parties to this Agreement.
38. This Agreement will be governed by and construed in accordance with the laws of the State of Mississippi, including the Mississippi uniform Commercial Code and the Seller and the Buyer hereby submit to the jurisdiction of the courts of the State of Mississippi.
39. Except where otherwise stated in this Agreement, all terms employed in this Agreement will have the same definition as set forth in the uniform Commercial Code in effect in the state of Mississippi on the date of execution of this Agreement.
40. If any clause of this Agreement is held unconscionable by any court of competent jurisdiction, arbitration panel or other official Finder of fact, the clause will be altered/deleted from this Agreement and the balance of this Agreement will remain in full force and effect.
41. This Agreement will endure to the benefit of and be binding upon the Seller and the Buyer and their respective successors and assigns.
42. This Agreement may be executed in counterparts. Facsimile/Email/Digital signatures are binding and are considered to be original signatures.
43. Time is of the essence and this Agreement.
44. This Agreement constitutes the entire Agreement between the parties and there are no further items or provisions, either oral or otherwise. The Buyer acknowledges that it has not relied upon any representation of the Seller as to prospective performance of the Goods but has relied upon its own inspection and investigation of the subject matter.

In witness whereof the parties have executed this sales Agreement on this _____ day of _____, 2023.

For Buyer: City of Jackson, Mississippi

For Seller: Active Solutions, LLC

Signature: _____

Signature: _____

Print Name: _____

Print Name: _____

Date: _____

Date: _____

Office of the City Attorney

455 East Capitol Street
Post Office Box 2779
Jackson, Mississippi 39207-2779
Telephone: (601) 960-1799
Facsimile: (601) 960-1756

OFFICE OF THE CITY ATTORNEY

This **ORDER ACCEPTING THE BID OF ACTIVE SOLUTIONS, LLC FOR A (36) MONTH SUPPLY OF SAFECITYCAM SURVEILLANCE CAMERAS AND INSTALLATION AND AUTHORIZING THE MAYOR TO EXECUTR A SALES AGREEMENT BETWEEN THE CITY OF JACKSON AND ACTIVE SOLUTIONS, LLC** is legally sufficient for placement in NOVUS Agenda.



Catoria Martin, City Attorney

Sondra Moncure, Deputy City Attorney *A.M.*

5/12/23
Date

26

OFFICE OF THE CITY ATTORNEY
5/19/23
S.M.C.

ORDER AUTHORIZING THE CONTRIBUTION OF MATCHING FUNDS TO VARIOUS ORGANIZATIONS FOR THE PURPOSE OF SUPPORTING THE DEVELOPMENT OF THE ARTS OR SOCIAL AND COMMUNITY SERVICE PROGRAMS AND AUTHORIZING THE MAYOR TO EXECUTE CONTRACTS WITH THE ENTITIES RECEIVING MATCHING FUNDS.

WHEREAS, Section 39-15-1 of the Mississippi Code of 1972, as amended, authorizes and empowers, in their discretion, to expend monies from the municipal general fund to match any other funds available for the purpose of supporting the development, promotion, and coordination of the arts in the municipality; and

WHEREAS, Section 21-19-65 of Mississippi Code of 1972, as amended, authorizes the governing authorities of this municipality the power to expend monies from the municipal general fund to match other funds for the purpose of supporting social and community service programs; and

WHEREAS, consistent with the provisions of Section 39-15-1 and Section 21-19-65 of the Mississippi Code of 1972, as amended, the governing authorities for the City of Jackson allocated monies in its budget for the 2022-2023 fiscal year to be expended for the promotion and development of the arts in the municipality and the support of social and community service programs; and

WHEREAS, the Department of Human and Cultural Services issued a Request for Proposals to solicit a response from art groups and other community organizations for art and cultural project that impact at least 350 people per project in the City of Jackson. The maximum award is \$10,000.00; and

WHEREAS, the administration evaluated the applications and determined that the following entities are eligible to receive the matching funds pursuant to Section 39-15-1 or Section 21-19-65 and recommend that the budgeted funds be awarded to the following organizations to match other funds for either the development, promotion, or coordination of the arts or the support of a social and community service program; and

Arts and Community Grants

1	YOUNG GIFTED & EMPOWERED 26 Avery Circle Jackson, MS 39211 savvyincpr@gmail.com	Shameka Reed	\$10,000
2	CENTER FOR SOCIAL ENTREPRENEURSHIP 1225 Robinson Street Jackson, MS 39203 shante.cse.ms@gmail.com	Shante Crockett	\$8,842

Agenda Item No. 26
May 23, 2023
(Wright, Lumumba)

3	JACKSON MUSIC AWARD EVENT 1 GOSPEL P. O. Box 20005, Westland Station Jackson MS 39209 jthompson.jmaa@gmail.com	Jesse Thompson	\$10,000
4	JACKSON MUSIC AWARD EVENT 2 R&B P. O. Box 20005, Westland Station Jackson MS 39209 jthompson.jmaa@gmail.com	Jesse Thompson	\$10,000
5	DOG GONE DITION FESTIVAL Adams 401 E. South St. Unit 2647 Jackson MS 39207 randywildmanbrown@gmail.com	Rander Phillip	\$10,000
6	WEST JACKSON COMMUNITY DEVELOPMENT CORP. 1328 Highway 80 West Jackson MS 39204 linda.carter@jsums.edu	Linda Carter	\$10,000
7	USA INTERNATIONAL BALLET COMPETITION P. O. Box 3696 Jackson, MS 39207 mnicholas@usaibc.com	Mona Nicholas	\$10,000
8	TEST-TAKING SOLUTION FOUNDATION MD, MBA Thousand Oaks Drive Jackson MS 39232 Founder@ttsfoundation.org	Kenrell Liddell	\$10,000
9	SHOWTIME AT JACKSON 3733 Azalea Drive Jackson, MS 39206 fredniaperkins@ymail.com	Fredia Perkins	\$10,000
	TOTAL		\$88,842.00

IT IS HEREBY ORDERED, that the matchings monies in the amount set forth above are awarded to the entities as listed.

IT IS FURTHER ORDER, that the Mayor shall execute agreements with each of the Organizations listed that will govern the receipt of the matching funds contributed, copies of the agreements are attached hereto and made part of the minutes.

Item# _____

Date _____

By: Wright, Lumumba

CITY COUNCIL AGENDA

ITEM 10 POINT DATA SHEET

DATE: 04/18/2023

P O I N T S		C O M M E N T S																										
1.	Brief Description/Purpose	Order authorizing the contribution of matching funds for the purpose of supporting the development of the arts or social and community service program and authorizing the Mayor to execute contracts with various organizations.																										
2.	Public Policy Initiative <ul style="list-style-type: none"> ○ Youth & Education ○ Crime Prevention ○ Changes in City Government ○ Neighborhood Enhancement ○ Economic Development ○ Infrastructure and Transportation ○ Quality of Life 	Quality of Life Economic Development																										
3.	Who will be affected	The general public																										
4.	Benefits	Increased and improved services in the City of Jackson																										
5.	Schedule (Beginning date) (Completion date)	As soon as approved																										
6.	Location: Ward: CITYWIDE (yes or no) (area) Project limits if applicable	Citywide																										
7.	Action implemented by: <ul style="list-style-type: none"> ○ Mayor's Office ○ City Department ○ Consultant 	Department of Human and Cultural Services																										
8.	COST	<table border="1" style="width: 100%; border-collapse: collapse;"> <tbody> <tr><td>YOUNG GIFTED & EMPOWERED</td><td align="right">\$10,000</td></tr> <tr><td>CENTER FOR SOCIAL ENTREPRENEURSHIP</td><td align="right">\$8,842</td></tr> <tr><td>JACKSON MUSIC AWARD EVENT 1 GOSPEL</td><td align="right">\$10,000</td></tr> <tr><td>JACKSON MUSIC AWARD EVENT 2 R&B</td><td align="right">\$10,000</td></tr> <tr><td>DOG GONE DITION FESTIVAL</td><td align="right">\$10,000</td></tr> <tr><td>WEST JACKSON COMMUNITY DEVELOPMENT CORP</td><td align="right">\$10,000</td></tr> <tr><td>USA INTERNATIONAL BALLET COMPETITION</td><td align="right">\$10,000</td></tr> <tr><td>TEST-TAKING SOLUTION FOUNDATION</td><td align="right">\$10,000</td></tr> <tr><td>SHOWTIME AT JACKSON</td><td align="right">\$10,000</td></tr> <tr><td>Total</td><td align="right">\$88,842</td></tr> </tbody> </table>						YOUNG GIFTED & EMPOWERED	\$10,000	CENTER FOR SOCIAL ENTREPRENEURSHIP	\$8,842	JACKSON MUSIC AWARD EVENT 1 GOSPEL	\$10,000	JACKSON MUSIC AWARD EVENT 2 R&B	\$10,000	DOG GONE DITION FESTIVAL	\$10,000	WEST JACKSON COMMUNITY DEVELOPMENT CORP	\$10,000	USA INTERNATIONAL BALLET COMPETITION	\$10,000	TEST-TAKING SOLUTION FOUNDATION	\$10,000	SHOWTIME AT JACKSON	\$10,000	Total	\$88,842	
YOUNG GIFTED & EMPOWERED	\$10,000																											
CENTER FOR SOCIAL ENTREPRENEURSHIP	\$8,842																											
JACKSON MUSIC AWARD EVENT 1 GOSPEL	\$10,000																											
JACKSON MUSIC AWARD EVENT 2 R&B	\$10,000																											
DOG GONE DITION FESTIVAL	\$10,000																											
WEST JACKSON COMMUNITY DEVELOPMENT CORP	\$10,000																											
USA INTERNATIONAL BALLET COMPETITION	\$10,000																											
TEST-TAKING SOLUTION FOUNDATION	\$10,000																											
SHOWTIME AT JACKSON	\$10,000																											
Total	\$88,842																											
9.	Source of Funding <ul style="list-style-type: none"> ○ General Fund ○ Enterprise ○ Grant ○ Bond Other	General Funds Acct# 001 43300 6742																										
10.	EBO participation	ABE	%	WAIVER	yes	no	N/A																					
		AABE	%	WAIVER	yes	no	N/A																					
		WBE	%	WAIVER	yes	no	N/A																					
		HBE	%	WAIVER	yes	no	N/A																					
		NABE	%	WAIVER	yes	no	N/A																					

MEMORANDUM

To: Chokwe Antar Lumumba
 Mayor

From: Mr. Louis P. Wright Sr. *LPW*
 Chief Administrative Officer

Date: April 18, 2023

Subject: Grant Recommendations

City of Jackson staff have reviewed and evaluated the Cultural Arts and Community Based proposals submitted for funding from the general fund. Based on the rating system used by staff the organizations listed below are the recommendations made for funding.

Arts and Community Grants

1	YOUNG GIFTED & EMPOWERED 26 Avery Circle Jackson, MS 39211 savvyincpr@gmail.com	Shameka Reed 601 594 1485	\$10,000
2	CENTER FOR SOCIAL ENTREPRENEURSHIP 1225 Robinson Street Jackson, MS 39203 shante.cse.ms@gmail.com	Shante Crockett 769 216 2012	\$8,842
3	JACKSON MUSIC AWARD EVENT 1 GOSPEL P. O. Box 20005, Westland Station Jackson MS 39209 jthompson.jmaa@gmail.com	Jesse Thompson 601 981 4035	\$10,000
4	JACKSON MUSIC AWARD EVENT 2 R&B P. O. Box 20005, Westland Station Jackson MS 39209 jthompson.jmaa@gmail.com	Jesse Thompson 601 981 4035	\$10,000
5	DOG GONE DITION FESTIVAL 401 E. South St. Unit 2647 Jackson MS 39207 randywildmanbrown@gmail.com	Rander Phillip Adams 601 664 8468	\$10,000
6	WEST JACKSON COMMUNITY DEVELOPMENT CORP 1328 Highway 80 West Jackson MS 39204 linda.carter@jsums.edu	Linda H. Carter 601 946 9310	\$10,000
7	USA INTERNATIONAL BALLET COMPETITION P. O. Box 3696 Jackson, MS 39207 mnicholas@usaibc.com	Mona Nicholas 601 355 9853	\$10,000

TEST-TAKING SOLUTION FOUNDATION	Kenrell Liddell, MD, MBA	601 741 8378	\$10,000
2104 Thousand Oaks Drive	Jackson MS 39232		
Founder@ttsfoundation.org			
SHOWTIME AT JACKSON	Fredia Perkins	601 613 3934	\$10,000
3733 Azalea Drive	Jackson, MS 39206		
fredniaperkins@ymail.com			
TOTAL			\$88,842

I am requesting this item be placed on the Council agenda.

Should you have questions or concerns regarding this matter, please do not hesitate to notify me.

MEMORANDUM OF UNDERSTANDING

WHEREAS, this Memorandum of Understanding (hereinafter referred to as "MOU") is made and entered into by and between the **CITY OF JACKSON, MISSISSIPPI**, hereinafter referred to as "City", and the **YOUNG, GIFTED & EMPOWERED**, hereinafter referred to as the "Agency," whose address is 26 Avery Circle Jackson, Mississippi 39211; and

WHEREAS, Section 39-15-1 of the Mississippi Code of 1972, as amended, authorizes and empowers, in their discretion, to expend monies from the municipal general fund to match any other funds available for the purpose of supporting the development, promotion, and coordination of the arts in the municipality; and

WHEREAS, Section 21-19-65 of Mississippi Code of 1972, as amended, authorizes the governing authorities of this municipality the power to expend monies from the municipal general fund to match other funds for the purpose of supporting social and community service programs; and

WHEREAS, consistent with the provisions of Section 39-15-1 and Section 21-19-65 of the Mississippi Code of 1972, as amended, the governing authorities for the City of Jackson allocated monies in its budget for the 2022-2023 fiscal year to be expended for the promotion and development of the arts in the municipality and the support of social and community service programs; and

WHEREAS, the Department of Human and Cultural Services issued a Request for Proposals to solicit a response from art groups and other community organizations for art and cultural project that impact at least 350 people per project in the City of Jackson. The maximum award is \$10,000.00; and

WHEREAS, the governing authorities for the City of Jackson approved an Order authorizing a matching grant, on a reimbursement basis, to Young, Gifted, & Empowered Media, LLC to provide support on August 25, 2023 for the YG&E Youth Media & Storytelling Summit for high school students enrolled in Jackson Public School District within the City of Jackson; and

WHEREAS, the Jackson City Council awarded the payment of matching funds in the amount of Ten Thousand Dollars and No Cents (\$10,000.00); and

WHEREAS, it is the parties' intent to commit to writing those terms and provisions which shall govern their relationship and the use of the monies appropriated.

WITNESSETH:

NOW, THEREFORE, in consideration of the mutual benefits and advantages each to the other, the receipt and sufficiency of which are hereby acknowledged, the City and Young, Gifted & Empowered, LLC agree as follows:

1. The Agency's Executive Director shall oversee the management and coordination of all activities for the youth summit on August 25, 2023, the YG&E Youth Media and Storytelling Summit for at least 350 high school students enrolled in the Jackson Public School District.

2. The Agency shall provide to the City reports on its activities, expenditure, and the availability of matching funds and as a condition precedent to receiving the funds allocated.
3. The Agency agrees to match funds contributed by the City with dollars from other funding sources consistent with the requirements of Section 39-15-1 and Section 21-19-65 of the Mississippi Code of 1972, as amended.
4. The City shall provide the Agency funds in the amount of Ten Thousand Dollars (\$10,000.00) with written documentation evidencing the matching funds when the request for reimbursement is submitted. Any final request for reimbursement must be submitted by the Agency on or before September 5, 2023. Any allocated funds not requested on or before September 5, 2023, will not be approved for payment. The receipt of the written documentation evidencing the matching funds is a condition precedent to receiving the matching or reimbursement funds allocated
5. The Agency agrees to match funds contributed by the City with at least 50% from other funding sources consistent with the requirement of Section 39-15-1 of the Mississippi Code.
6. The parties agree that the Agency has provided to the City a budget for its 2022 – 2023 fiscal year. Revisions in the Agency’s budget line items shall require prior written approval of the City’s Director of the Department of Human and Cultural Services.
7. This MOU shall commence upon execution and end on September 30, 2023.
8. The Agency shall maintain all financial and programmatic records, documents and other evidence related to the expenditure of funds for a minimum of three (3) years. Records that must be maintained include, but shall not be limited to, monthly bank statements showing all disbursement of the funds contributed by the City of Jackson, related invoices, and expense records. The form of such records and reports shall conform to generally accepted accounting practices, and shall sufficiently and properly reflect all direct and indirect costs of any nature expended in the performance of this MOU shall be utilized.
9. The City, or its authorized representative shall have the right, at any reasonable time, to examine the books and records of the Agency pertaining to the funds related to this MOU. Further, the Agency shall allow the City at any time, and from time to time, during reasonable business hours, to audit the books of the Agency and secure such other records and documents as may be necessary and appropriate under the rules and regulations of the City.
10. The Agency will not discriminate on the basis of race, color, religion, sex (including pregnancy, sexual orientation, or gender identity), national origin, age, disability, and genetic information (including family medical history).

11. The parties agree that the City's contribution under this agreement is subject to the continued availability of funding and is contingent upon the City receiving sufficient revenues during the budget year to provide the monies allocated.
12. The City may, without cause, terminate the MOU upon giving thirty (30) days written notice to the Agency.
13. In the event the Agency fails to comply with any provision of this MOU, the City may terminate the MOU upon giving thirty (30) days written notice to the Agency.
14. The Agency agrees to indemnify and hold harmless the City, its officers, and its employees from any act of or omission of the Agency, its employees, agency or servants, that results in the bodily injury, property damage, death of any party, or any other claims for damages growing out the performance of this MOU.
15. The parties agree that the provision of this MOU shall be construed according to the laws of the State of Mississippi.
16. The parties agree that the provisions of this MOU constitute their entire agreement, and no prior oral or written representations shall be effective and operate to amend, alter, or vary the terms of this MOU.
17. The parties agree that this MOU may not be modified except upon prior written consent and agreement of the parties.
18. The parties agree that any and all remedies available at law and equity may be asserted by the City in the event of default or breach and shall not be waived.

IN WITNESS WHEREOF, this Contract is executed by the parties hereto on this, the

_____ day of _____, 2023.

CITY OF JACKSON, MISSISSIPPI

BY: _____
Chokwe A. Lumumba, Mayor

ATTEST:

Angela Harris, Municipal Clerk

Young, Gifted & Empowered

BY: _____
Director

MEMORANDUM OF UNDERSTANDING

WHEREAS, this Memorandum of Understanding (hereinafter referred to as "MOU") is made and entered into by and between the **CITY OF JACKSON, MISSISSIPPI**, hereinafter referred to as "City", and the **CENTER FOR SOCIAL ENTREPRENEURSHIP** hereinafter referred to as the "Agency," whose address is 1225 Robinson Street Jackson, Mississippi 39203; and

WHEREAS, Section 39-15-1 of the Mississippi Code of 1972, as amended, authorizes and empowers, in their discretion, to expend monies from the municipal general fund to match any other funds available for the purpose of supporting the development, promotion, and coordination of the arts in the municipality; and

WHEREAS, Section 21-19-65 of Mississippi Code of 1972, as amended, authorizes the governing authorities of this municipality the power to expend monies from the municipal general fund to match other funds for the purpose of supporting social and community service programs; and

WHEREAS, consistent with the provisions of Section 39-15-1 and Section 21-19-65 of the Mississippi Code of 1972, as amended, the governing authorities for the City of Jackson allocated monies in its budget for the 2022-2023 fiscal year to be expended for the promotion and development of the arts in the municipality and the support of social and community service programs; and

WHEREAS, the Department of Human and Cultural Services issued a Request for Proposals to solicit a response from art groups and other community organizations for art and cultural project that impact at least 350 people per project in the City of Jackson. The maximum award is \$10,000.00; and

WHEREAS, the governing authorities for the City of Jackson approved an order authorizing a matching grant, on a reimbursement basis, to Center for Social Entrepreneurship to provide support for the iVillage – An uplifting Mural of a community Icon & Celebration of Neighborhood Heroes within the City of Jackson; and

WHEREAS, the Jackson City Council awarded the payment of matching funds in the amount of Eight Thousand Eight Hundred Forty-Two Dollars and No Cents (\$8,842.00); and

WHEREAS, it is the parties' intent to commit to writing those terms and provisions which shall govern their relationship and the use of the monies appropriated.

WITNESSETH:

NOW, THEREFORE, in consideration of the mutual benefits and advantages each to the other, the receipt and sufficiency of which are hereby acknowledged, the City and Center for Social Entrepreneurship agree as follows:

1. The Agency shall provide oversight and management for all activities for the provision for the iVillage – An uplifting Mural of a Community Icon & Celebration of Neighborhood Heroes: Growing Pride for Our Neighborhood & University. The Agency shall ensure that at least 400 persons will benefit from this project.

2. The Agency shall provide to the City reports on its activities, expenditure, and the availability of matching funds and as a condition precedent to receiving the funds allocated.
3. The Agency agrees to match funds contributed by the City with dollars from other funding sources consistent with the requirements of Section 39-15-1 and Section 21-19-65 of the Mississippi Code of 1972, as amended.
4. The Agency shall provide the City with written documentation evidencing the matching funds when the request for reimbursement is submitted. Any final request for reimbursement must be submitted by the Agency on or before September 5, 2023. Any allocated funds not requested on or before September 5, 2023, will not be approved for payment. The receipt of the written documentation evidencing the matching funds is a condition precedent to receiving the matching or reimbursement funds allocated
5. The Agency agrees to match funds contributed by the City with at least 50% from other funding sources consistent with the requirement of Section 39-15-1 of the Mississippi Code.
6. This MOU shall commence upon execution and end on September 30, 2023.
7. The City shall provide funds up to Eight Thousand Eight Hundred Forty-Two Dollars and No Cents (\$8,842.00), to the Agency, on a reimbursement and matching funds basis, for performance of the services set forth and specified herein.
8. The Agency shall maintain all financial and programmatic records, documents and other evidence related to the expenditure of funds for a minimum of three (3) years. Records that must be maintained include, but shall not be limited to: bank statements showing the disbursement of the funds contributed by the City of Jackson, related invoice, and expense records. The form of such records and reports shall conform to generally accepted accounting practices, and shall sufficiently and properly reflect all direct and indirect costs of any nature expended in the performance of this MOU shall be utilized.
9. The City, or its authorize representative shall have the right, at any reasonable time, to examine the books and records of the Agency pertaining to the funds related to this MOU. Further, the Agency shall allow the City at any time, and from time to time, during reasonable business hours, to audit the books of the Agency and secure such other records and documents as may be necessary and appropriate under the rules and regulations of the City.
10. The Agency will not discriminate on the basis of race, color, religion, sex (including pregnancy, sexual orientation, or gender identity), national origin, age, disability, and genetic information (including family medical history).
11. The parties agree that the City's contribution under this agreement is subject to the continued availability of funding and is contingent upon the City receiving sufficient revenues during the budget year to provide the monies allocated.

12. The City may, without cause, terminate the MOU upon giving thirty (30) days written notice to the Agency.
13. In the event the Agency fails to comply with any provision of this MOU, the City may terminate the MOU upon giving thirty (30) days written notice to the Agency.
14. The Agency agrees to indemnify and hold harmless the City, its officers, and its employees from any act of or omission of the Agency, its employees, agency or servants, that results in the bodily injury, property damage, death of any party, or any other claims for damages growing out the performance of this MOU.
15. The parties agree that the provision of this MOU shall be construed according to the laws of the State of Mississippi.
16. The parties agree that the provisions of this MOU constitute their entire agreement, and no prior oral or written representations shall be effective and operate to amend, alter, or vary the terms of this MOU.
17. The parties agree that this MOU may not be modified except upon prior written consent and agreement of the parties.
18. The parties agree that any and all remedies available at law and equity may be asserted by the City in the event of default or breach and shall not be waived.

IN WITNESS WHEREOF, this Contract is executed by the parties hereto on this, the

_____ day of _____, 2023.

CITY OF JACKSON, MISSISSIPPI

BY: _____
Chokwe A. Lumumba, Mayor

ATTEST:

Angela Harris, Municipal Clerk

CENTER FOR SOCIAL ENTREPRENEURSHIP

BY: _____
Director

MEMORANDUM OF UNDERSTANDING

WHEREAS, this Memorandum of Understanding (hereinafter referred to as "MOU") is made and entered into by and between the **CITY OF JACKSON, MISSISSIPPI**, hereinafter referred to as "City", and the **JACKSON MUSIC AWARDS ASSOCIATION, INC.** hereinafter referred to as the "Agency," whose address is 6418 Whitestone Road Jackson, Mississippi 39206; and

WHEREAS, Section 39-15-1 of the Mississippi Code of 1972, as amended, authorizes and empowers, in their discretion, to expend monies from the municipal general fund to match any other funds available for the purpose of supporting the development, promotion, and coordination of the arts in the municipality; and

WHEREAS, Section 21-19-65 of Mississippi Code of 1972, as amended, authorizes the governing authorities of this municipality the power to expend monies from the municipal general fund to match other funds for the purpose of supporting social and community service programs; and

WHEREAS, consistent with the provisions of Section 39-15-1 and Section 21-19-65 of the Mississippi Code of 1972, as amended, the governing authorities for the City of Jackson allocated monies in its budget for the 2022-2023 fiscal year to be expended for the promotion and development of the arts in the municipality and the support of social and community service programs; and

WHEREAS, the Department of Human and Cultural Services issued a Request for Proposals to solicit a response from art groups and other community organizations for art and cultural project that impact at least 350 people per project in the City of Jackson. The maximum award is \$10,000.00; and

WHEREAS, the governing authorities for the City of Jackson approved an Order authorizing the award of a matching grant, on a reimbursement basis, to Jackson Music Awards Association, Inc. to provide support on July 24, 2023 for the 49th Annual Jackson Music Awards Event at the Jackson Convention Center's Trustmark Ballroom within the City of Jackson; and

WHEREAS, the Jackson City Council awarded the payment of matching funds in the amount of Ten Thousand Dollars and No Cents (\$10,000.00); and

WHEREAS, it is the parties' intent to commit to writing those terms and provisions which shall govern their relationship and the use of the monies appropriated.

WITNESSETH:

NOW, THEREFORE, in consideration of the mutual benefits and advantages each to the other, the receipt and sufficiency of which are hereby acknowledged, the City and the Jackson Music Awards Association Inc. agree as follows:

1. The Agency shall provide oversight and management for all activities for the provision for the 49th Annual Jackson Music Awards held at the Jackson Convention Center's Trustmark Ballroom. This event creates awareness and exposure for the musical talents of numerous artists from the South and Southeast. This event will honor the Kings and Queens of Soul.

2. The Agency shall provide to the City reports on its activities, expenditure, and the availability of matching funds and as a condition precedent to receiving the funds allocated.
3. The Agency shall provide the City with written documentation evidencing the matching funds when the request for reimbursement is submitted. Any final request for reimbursement must be submitted by the Agency on or before September 5, 2023. Any allocated funds not requested on or before September 5, 2023, will not be approved for payment. The receipt of the written documentation evidencing the matching funds is a condition precedent to receiving the matching or reimbursement funds allocated.
4. The Agency agrees to match funds contributed by the City with dollars from other funding sources consistent with the requirements of Section 39-15-1 and Section 21-19-65 of the Mississippi Code of 1972, as amended.
5. The Agency agrees to match funds contributed by the City with at least 50% from other funding sources consistent with the requirement of Section 39-15-1 of the Mississippi Code.
6. This MOU shall commence upon execution and end on September 30, 2023.
7. The City shall provide funds up to Ten Thousand Dollars and No Cents (\$10,000.00), to the Agency, on a reimbursement and matching funds basis, for performance of the services set forth and specified herein.
8. The Agency shall maintain all financial and programmatic records, documents and other evidence related to the expenditure of funds for a minimum of three (3) years. Records that must be maintained include, but shall not be limited to: bank statements showing the disbursement of the funds contributed by the City of Jackson, related invoice, and expense records. The form of such records and reports shall conform to generally accepted accounting practices, and shall sufficiently and properly reflect all direct and indirect costs of any nature expended in the performance of this MOU shall be utilized.
9. The City, or its authorize representative shall have the right, at any reasonable time, to examine the books and records of the Agency pertaining to the funds related to this MOU. Further, the Agency shall allow the City at any time, and from time to time, during reasonable business hours, to audit the books of the Agency and secure such other records and documents as may be necessary and appropriate under the rules and regulations of the City.
10. The Agency will not discriminate on the basis of race, color, religion, sex (including pregnancy, sexual orientation, or gender identity), national origin, age, disability, and genetic information (including family medical history).
11. The parties agree that the City's contribution under this agreement is subject to the

continued availability of funding and is contingent upon the City receiving sufficient revenues during the budget year to provide the monies allocated.

12. The City may, without cause, terminate the MOU upon giving thirty (30) days written notice to the Agency.
13. In the event the Agency fails to comply with any provision of this MOU, the City may terminate the MOU upon giving thirty (30) days written notice to the Agency.
14. The Agency agrees to indemnify and hold harmless the City, its officers, and its employees from any act of or omission of the Agency, its employees, agency or servants, that results in the bodily injury, property damage, death of any party, or any other claims for damages growing out the performance of this MOU.
15. The parties agree that the provision of this MOU shall be construed according to the laws of the State of Mississippi.
16. The parties agree that the provisions of this MOU constitute their entire agreement, and no prior oral or written representations shall be effective and operate to amend, alter, or vary the terms of this MOU.
17. The parties agree that this MOU may not be modified except upon prior written consent and agreement of the parties.
18. The parties agree that any and all remedies available at law and equity may be asserted by the City in the event of default or breach and shall not be waived.

IN WITNESS WHEREOF, this Contract is executed by the parties hereto on this, the

_____ day of _____, 2023.

CITY OF JACKSON, MISSISSIPPI

BY: _____
Chokwe A. Lumumba, Mayor

ATTEST:

Angela Harris, Municipal Clerk

**JACKSON MUSIC AWARDS
ASSOCIATION, INC.**

BY: _____
Director

MEMORANDUM OF UNDERSTANDING

WHEREAS, this Memorandum of Understanding (hereinafter referred to as "MOU") is made and entered into by and between the **CITY OF JACKSON, MISSISSIPPI**, hereinafter referred to as "City", and the **JACKSON MUSIC AWARDS ASSOCIATION, INC.** hereinafter referred to as the "Agency," whose address is 6418 Whitestone Road Jackson, Mississippi 39206; and

WHEREAS, Section 39-15-1 of the Mississippi Code of 1972, as amended, authorizes and empowers, in their discretion, to expend monies from the municipal general fund to match any other funds available for the purpose of supporting the development, promotion, and coordination of the arts in the municipality; and

WHEREAS, Section 21-19-65 of Mississippi Code of 1972, as amended, authorizes the governing authorities of this municipality the power to expend monies from the municipal general fund to match other funds for the purpose of supporting social and community service programs; and

WHEREAS, consistent with the provisions of Section 39-15-1 and Section 21-19-65 of the Mississippi Code of 1972, as amended, the governing authorities for the City of Jackson allocated monies in its budget for the 2022-2023 fiscal year to be expended for the promotion and development of the arts in the municipality and the support of social and community service programs; and

WHEREAS, the Department of Human and Cultural Services issued a Request for Proposals to solicit a response from art groups and other community organizations for art and cultural project that impact at least 350 people per project in the City of Jackson. The maximum award is \$10,000.00; and

WHEREAS, the governing authorities for the City of Jackson approved an order authorizing the award of a matching grant, on a reimbursement basis, to Jackson Music Awards Association, Inc. to provide support on July 23, 2023 for the 45th Annual Gospel Music Awards Event at the Jackson Convention Center's Trustmark Ballroom within the City of Jackson; and

WHEREAS, the Jackson City Council awarded the payment of matching funds in the amount of Ten Thousand Dollars and No Cents (\$10,000.00); and

WHEREAS, it is the parties' intent to commit to writing those terms and provisions which shall govern their relationship and the use of the monies appropriated.

WITNESSETH:

NOW, THEREFORE, in consideration of the mutual benefits and advantages each to the other, the receipt and sufficiency of which are hereby acknowledged, the City and the Jackson Music Awards Association Inc. agree as follows:

1. The Agency shall provide oversight and management for all activities for the provision for the July 23, 2023, 45th Annual Mississippi Gospel Music Awards Event at the Jackson Center's Trustmark Ballroom. This event will create awareness and exposure for the musical talents of numerous artists throughout the South and Southeast.

2. The Agency shall provide to the City reports on its activities, expenditure, and the availability of matching funds and as a condition precedent to receiving the funds allocated.
3. The Agency agrees to match funds contributed by the City with dollars from other funding sources consistent with the requirements of Section 39-15-1 and Section 21-19-65 of the Mississippi Code of 1972, as amended.
4. The Agency shall provide the City with written documentation evidencing the matching funds when the request for reimbursement is submitted. Any final request for reimbursement must be submitted by the Agency on or before September 5, 2023. Any allocated funds not requested on or before September 5, 2023, will not be approved for payment. The receipt of the written documentation evidencing the matching funds is a condition precedent to receiving the matching or reimbursement funds allocated
5. The Agency agrees to match funds contributed by the City with at least 50% from other funding sources consistent with the requirement of Section 39-15-1 of the Mississippi Code.
6. This MOU shall commence upon execution and end on September 30, 2023.
7. The City shall provide funds up to Ten Thousand Dollars and No Cents (\$10,000.00), to the Agency, on a reimbursement and matching funds basis, for performance of the services set forth and specified herein.
8. The Agency shall maintain all financial and programmatic records, documents and other evidence related to the expenditure of funds for a minimum of three (3) years. Records that must be maintained include, but shall not be limited to: bank statements showing the disbursement of the funds contributed by the City of Jackson, related invoice, and expense records. The form of such records and reports shall conform to generally accepted accounting practices, and shall sufficiently and properly reflect all direct and indirect costs of any nature expended in the performance of this MOU shall be utilized.
9. The City, or its authorize representative shall have the right, at any reasonable time, to examine the books and records of the Agency pertaining to the funds related to this MOU. Further, the Agency shall allow the City at any time, and from time to time, during reasonable business hours, to audit the books of the Agency and secure such other records and documents as may be necessary and appropriate under the rules and regulations of the City.
10. The Agency will not discriminate on the basis of race, color, religion, sex (including pregnancy, sexual orientation, or gender identity), national origin, age, disability, and genetic information (including family medical history).
11. The parties agree that the City's contribution under this agreement is subject to the continued availability of funding and is contingent upon the City receiving sufficient

revenues during the budget year to provide the monies allocated.

12. The City may, without cause, terminate the MOU upon giving thirty (30) days written notice to the Agency.
13. In the event the Agency fails to comply with any provision of this MOU, the City may terminate the MOU upon giving thirty (30) days written notice to the Agency.
14. The Agency agrees to indemnify and hold harmless the City, its officers, and its employees from any act of or omission of the Agency, its employees, agency or servants, that results in the bodily injury, property damage, death of any party, or any other claims for damages growing out the performance of this MOU.
15. The parties agree that the provision of this MOU shall be construed according to the laws of the State of Mississippi.
16. The parties agree that the provisions of this MOU constitute their entire agreement, and no prior oral or written representations shall be effective and operate to amend, alter, or vary the terms of this MOU.
17. The parties agree that this MOU may not be modified except upon prior written consent and agreement of the parties.
18. The parties agree that any and all remedies available at law and equity may be asserted by the City in the event of default or breach and shall not be waived.

IN WITNESS WHEREOF, this Contract is executed by the parties hereto on this, the

_____ day of _____, 2023.

CITY OF JACKSON, MISSISSIPPI

BY: _____
Chokwe A. Lumumba, Mayor

ATTEST:

Angela Harris, Municipal Clerk

**JACKSON MUSIC AWARDS
ASSOCIATION, INC.**

BY: _____
Director

MEMORANDUM OF UNDERSTANDING

WHEREAS, this Memorandum of Understanding (hereinafter referred to as "MOU") is made and entered into by and between the **CITY OF JACKSON, MISSISSIPPI**, hereinafter referred to as "City", and **DOG GONE DITION FESTIVAL** hereinafter referred to as the "Agency," whose address is 401 E South Street, Unit 2647 Jackson, Mississippi 39207; and

WHEREAS, Section 39-15-1 of the Mississippi Code of 1972, as amended, authorizes and empowers, in their discretion, to expend monies from the municipal general fund to match any other funds available for the purpose of supporting the development, promotion, and coordination of the arts in the municipality; and

WHEREAS, Section 21-19-65 of Mississippi Code of 1972, as amended, authorizes the governing authorities of this municipality the power to expend monies from the municipal general fund to match other funds for the purpose of supporting social and community service programs; and

WHEREAS, consistent with the provisions of Section 39-15-1 and Section 21-19-65 of the Mississippi Code of 1972, as amended, the governing authorities for the City of Jackson allocated monies in its budget for the 2022-2023 fiscal year to be expended for the promotion and development of the arts in the municipality and the support of social and community service programs; and

WHEREAS, the Department of Human and Cultural Services issued a Request for Proposals to solicit a response from art groups and other community organizations for art and cultural project that impact at least 350 people per project in the City of Jackson. The maximum award is \$10,000.00; and

WHEREAS, the governing authorities for the City of Jackson approved an Order authorizing the award of a matching grant, on a reimbursement basis, to Dog gone Dition Festival to provide support on August 5, 2023 for the 13th Annual Dog Gone Dition Festival in West Jackson; and

WHEREAS, the Jackson City Council awarded the payment of matching funds in the amount of Ten Thousand Dollars and No Cents (\$10,000.00); and

WHEREAS, it is the parties' intent to commit to writing those terms and provisions which shall govern their relationship and the use of the monies appropriated.

WITNESSETH:

NOW, THEREFORE, in consideration of the mutual benefits and advantages each to the other, the receipt and sufficiency of which are hereby acknowledged, Dog Gone Dition Festival agree as follows:

1. The Agency shall provide oversight and management of all activities for the provision for the August 5, 2023, the 13th Annual Dog Gone Dition Festival, a drug-free back to school, "Unity in the Community, Silence the Violence-Increase the Peace," family event.

2. The Agency shall provide to the City reports on its activities, expenditure, and the availability of matching funds and as a condition precedent to receiving the funds allocated.
3. The Agency shall provide to the City reports on its activities, expenditure, and the availability of matching funds and as a condition precedent to receiving the funds allocated.
4. The Agency agrees to match funds contributed by the City with dollars from other funding sources consistent with the requirements of Section 39-15-1 and Section 21-19-65 of the Mississippi Code of 1972, as amended.
5. The Agency shall provide the City with written documentation evidencing the matching funds when the request for reimbursement is submitted. Any final request for reimbursement must be submitted by the Agency on or before September 5, 2023. Any allocated funds not requested on or before September 5, 2023 will not be approved for payment. The receipt of the written documentation evidencing the matching funds is a condition precedent to receiving the matching or reimbursement funds allocated
6. The Agency agrees to match funds contributed by the City with at least 50% from other funding sources consistent with the requirement of Section 39-15-1 of the Mississippi Code to support the August 5, 2023 The 13th Annual Dog Gone Dition Festival from 12:00pm to until within the City of Jackson.
7. The City shall provide funds up to Ten Thousand Dollars and No Cents (\$10,000.00), to the Agency, on a reimbursement and matching funds basis, for performance of the services set forth and specified herein.
8. This MOU shall be effective as of the date of the Jackson City Council's action awarding the funds and end on or before September 30, 2023.
9. The Agency shall maintain all financial and programmatic records, documents and other evidence related to the expenditure of funds for a minimum of three (3) years. Records that must be maintained include, but shall not be limited to: bank statements showing the disbursement of the funds contributed by the City of Jackson, related invoice, and expense records. The form of such records and reports shall conform to generally accepted accounting practices, and shall sufficiently and properly reflect all direct and indirect costs of any nature expended in the performance of this MOU shall be utilized.
10. The City, or its authorize representative shall have the right, at any reasonable time, to examine the books and records of the Agency pertaining to the funds related to this MOU. Further, the Agency shall allow the City at any time, and from time to time, during reasonable business hours, to audit the books of the Agency and secure such other records and documents as may be necessary and appropriate under the rules and regulations of the City.

11. The Agency will not discriminate on the basis of race, color, religion, sex (including pregnancy, sexual orientation, or gender identity), national origin, age, disability, and genetic information (including family medical history).
12. The parties agree that the City's contribution under this agreement is subject to the continued availability of funding and is contingent upon the City receiving sufficient revenues during the budget year to provide the monies allocated.
13. In the event the Agency fails to comply with any provision of this MOU, the City may terminate the MOU upon giving thirty (30) days written notice to the Agency.
14. The Agency agrees to indemnify and hold harmless the City, its officers, and its employees from any act of or omission of the Agency, its employees, agency or servants, that results in the bodily injury, property damage, death of any party, or any other claims for damages growing out the performance of this MOU.
15. The parties agree that the provision of this MOU shall be construed according to the laws of the State of Mississippi.
16. The parties agree that the provisions of this MOU constitute their entire agreement, and no prior oral or written representations shall be effective and operate to amend, alter, or vary the terms of this MOU.
17. The parties agree that this MOU may not be modified except upon prior written consent and agreement of the parties.
18. The parties agree that any and all remedies available at law and equity may be asserted by the City in the event of default or breach and shall not be waived.

IN WITNESS WHEREOF, this Contract is executed by the parties hereto on this, the

_____ day of _____, 2023.

CITY OF JACKSON, MISSISSIPPI

BY: _____
Chokwe A. Lumumba, Mayor

ATTEST:

Angela Harris, Municipal Clerk

DOG GONE DITION FESTIVAL

BY: _____
Director

MEMORANDUM OF UNDERSTANDING

WHEREAS, this Memorandum of Understanding (hereinafter referred to as "MOU") is made and entered into by and between the **CITY OF JACKSON, MISSISSIPPI**, hereinafter referred to as "City", and the **WEST JACKSON COMMUNITY DEVELOPMENT CORPORATION**, hereinafter referred to as the "Agency," whose address is 1328 Highway 80 West, Jackson, Mississippi 39204; and

WHEREAS, Section 39-15-1 of the Mississippi Code of 1972, as amended, authorizes and empowers, in their discretion, to expend monies from the municipal general fund to match any other funds available for the purpose of supporting the development, promotion, and coordination of the arts in the municipality; and

WHEREAS, Section 21-19-65 of Mississippi Code of 1972, as amended, authorizes the governing authorities of this municipality the power to expend monies from the municipal general fund to match other funds for the purpose of supporting social and community service programs; and

WHEREAS, consistent with the provisions of Section 39-15-1 and Section 21-19-65 of the Mississippi Code of 1972, as amended, the governing authorities for the City of Jackson allocated monies in its budget for the 2022-2023 fiscal year to be expended for the promotion and development of the arts in the municipality and the support of social and community service programs; and

WHEREAS, the Department of Human and Cultural Services issued a Request for Proposals to solicit a response from art groups and other community organizations for art and cultural project that impact at least 350 people per project in the City of Jackson. The maximum award is \$10,000.00; and

WHEREAS, the governing authorities for the City of Jackson approved an Order authorizing the award of a matching grant, on a reimbursement basis, to West Jackson Community Development Corporation to provide support on August 29, 2023 for the 30th Annual Lynch Street Cultural Arts Festival within the City of Jackson; and

WHEREAS, the Jackson City Council awarded the payment of matching funds in the amount of Ten Thousand Dollars and No Cents (\$10,000.00); and

WHEREAS, it is the parties' intent to commit to writing those terms and provisions which shall govern their relationship and the use of the monies appropriated.

WITNESSETH:

NOW, THEREFORE, in consideration of the mutual benefits and advantages each to the other, the receipt and sufficiency of which are hereby acknowledged, the City and West Jackson Community Development Corporation agree as follows:

1. The Agency shall provide oversight and management for all activities for the provision for the August 29, 2023, 30th Annual Lynch Street Cultural Arts Festival. The festival is one-day event sponsored to celebrate the rich cultural and artistic history of the historical Lynch Street in Jackson, MS.

2. The Agency shall provide to the City reports on its activities, expenditure, and the availability of matching funds and as a condition precedent to receiving the funds allocated.
3. The Agency shall provide the City with written documentation evidencing the matching funds when the request for reimbursement is submitted. Any final request for reimbursement must be submitted by the Agency on or before September 5, 2023. Any allocated funds not requested on or before September 5, 2023, will not be approved for payment. The receipt of the written documentation evidencing the matching funds is a condition precedent to receiving the matching or reimbursement funds allocated.
4. The Agency agrees to match funds contributed by the City with dollars from other funding sources consistent with the requirements of Section 39-15-1 and Section 21-19-65 of the Mississippi Code of 1972, as amended.
5. The Agency agrees to match funds contributed by the City with at least 50% from other funding sources consistent with the requirement of Section 39-15-1 of the Mississippi Code.
6. This MOU shall commence upon execution and end on September 30, 2023.
7. The City shall provide funds up to Ten Thousand Dollars and No Cents (\$10,000.00), to the Agency, on a reimbursement and matching funds basis, for performance of the services set forth and specified herein.
8. The Agency shall maintain all financial and programmatic records, documents and other evidence related to the expenditure of funds for a minimum of three (3) years. Records that must be maintained include, but shall not be limited to: bank statements showing the disbursement of the funds contributed by the City of Jackson, related invoice, and expense records. The form of such records and reports shall conform to generally accepted accounting practices, and shall sufficiently and properly reflect all direct and indirect costs of any nature expended in the performance of this MOU shall be utilized.
9. The City, or its authorize representative shall have the right, at any reasonable time, to examine the books and records of the Agency pertaining to the funds related to this MOU. Further, the Agency shall allow the City at any time, and from time to time, during reasonable business hours, to audit the books of the Agency and secure such other records and documents as may be necessary and appropriate under the rules and regulations of the City.
10. The Agency will not discriminate on the basis of race, color, religion, sex (including pregnancy, sexual orientation, or gender identity), national origin, age, disability, and genetic information (including family medical history).
11. The parties agree that the City's contribution under this agreement is subject to the

continued availability of funding and is contingent upon the City receiving sufficient revenues during the budget year to provide the monies allocated.

12. The City may, without cause, terminate the MOU upon giving thirty (30) days written notice to the Agency.
13. In the event the Agency fails to comply with any provision of this MOU, the City may terminate the MOU upon giving thirty (30) days written notice to the Agency .
14. The Agency agrees to indemnify and hold harmless the City, its officers, and its employees from any act of or omission of the Agency, its employees, agency or servants, that results in the bodily injury, property damage, death of any party, or any other claims for damages growing out the performance of this MOU.
15. The parties agree that the provision of this MOU shall be construed according to the laws of the State of Mississippi.
16. The parties agree that the provisions of this MOU constitute their entire agreement, and no prior oral or written representations shall be effective and operate to amend, alter, or vary the terms of this MOU.
17. The parties agree that this MOU may not be modified except upon prior written consent and agreement of the parties.
18. The parties agree that any and all remedies available at law and equity may be asserted by the City in the event of default or breach and shall not be waived.

IN WITNESS WHEREOF, this Contract is executed by the parties hereto on this, the _____ day of _____, 2023.

CITY OF JACKSON, MISSISSIPPI

BY: _____
Chokwe A. Lumumba, Mayor

ATTEST:

Angela Harris, Municipal Clerk

**West Jackson Community Development
Corporation**

BY: _____
Director

MEMORANDUM OF UNDERSTANDING

WHEREAS, this Memorandum of Understanding (hereinafter referred to as "MOU") is made and entered into by and between the **CITY OF JACKSON, MISSISSIPPI**, hereinafter referred to as "City", and **USA INTERNATIONAL BALLET** hereinafter referred to as the "Agency," whose address is P. O. Box 3696 Jackson, Mississippi 39207; and

WHEREAS, Section 39-15-1 of the Mississippi Code of 1972, as amended, authorizes and empowers, in their discretion, to expend monies from the municipal general fund to match any other funds available for the purpose of supporting the development, promotion, and coordination of the arts in the municipality; and

WHEREAS, Section 21-19-65 of Mississippi Code of 1972, as amended, authorizes the governing authorities of this municipality the power to expend monies from the municipal general fund to match other funds for the purpose of supporting social and community service programs; and

WHEREAS, consistent with the provisions of Section 39-15-1 and Section 21-19-65 of the Mississippi Code of 1972, as amended, the governing authorities for the City of Jackson allocated monies in its budget for the 2022-2023 fiscal year to be expended for the promotion and development of the arts in the municipality and the support of social and community service programs; and

WHEREAS, the Department of Human and Cultural Services issued a Request for Proposals to solicit a response from art groups and other community organizations for art and cultural project that impact at least 350 people per project in the City of Jackson. The maximum award is \$10,000.00; and

WHEREAS, the governing authorities for the City of Jackson approved an Order authorizing the award of a matching grant, on a reimbursement basis, to USA International Ballet Competition City Dance program; and

WHEREAS, the Jackson City Council awarded the payment of matching funds in the amount of Ten Thousand Dollars and No Cents (\$10,000.00); and

WHEREAS, it is the parties' intent to commit to writing those terms and provisions which shall govern their relationship and the use of the monies appropriated.

WITNESSETH:

NOW, THEREFORE, in consideration of the mutual benefits and advantages each to the other, the receipt and sufficiency of which are hereby acknowledged, the USA International Ballet agree as follows:

1. The Agency shall provide oversight and management of all activities for the provision for the USA International Ballet Competition – City Dance. The City Dance program which consists of ballet class auditions, ballet classes, city dance parent meeting, performance, city dance workshop, city dance art project, spring recital & city dance reception and art showcases through the Jackson Public Schools academic year, late September 2022 through May 2023.

2. The Agency shall provide to the City reports on its activities, expenditure, and the availability of matching funds and as a condition precedent to receiving the funds allocated.
3. The Agency agrees to match funds contributed by the City with dollars from other funding sources consistent with the requirements of Section 39-15-1 and Section 21-19-65 of the Mississippi Code of 1972, as amended.
4. The Agency shall provide the City with written documentation evidencing the matching funds when the request for reimbursement is submitted. Any final request for reimbursement must be submitted by the Agency on or before September 5, 2023. Any allocated funds not requested on or before September 5, 2023 will not be approved for payment. The receipt of the written documentation evidencing the matching funds is a condition precedent to receiving the matching or reimbursement funds allocated
5. The Agency agrees to match funds contributed by the City with at least 50% from other funding sources consistent with the requirement of Section 39-15-1 of the Mississippi Code.
6. The City shall provide funds up to Ten Thousand Dollars and No Cents (\$10,000.00), to the Agency, on a reimbursement and matching funds basis, for performance of the services set forth and specified herein.
7. This MOU shall be effective as of the date of the Jackson City Council's action awarding the funds and end on or before September 30, 2023.
8. The Agency shall maintain all financial and programmatic records, documents and other evidence related to the expenditure of funds for a minimum of three (3) years. Records that must be maintained include, but shall not be limited to: bank statements showing the disbursement of the funds contributed by the City of Jackson, related invoice, and expense records. The form of such records and reports shall conform to generally accepted accounting practices, and shall sufficiently and properly reflect all direct and indirect costs of any nature expended in the performance of this MOU shall be utilized.
9. The City, or its authorize representative shall have the right, at any reasonable time, to examine the books and records of the Agency pertaining to the funds related to this MOU. Further, the Agency shall allow the City at any time, and from time to time, during reasonable business hours, to audit the books of the Agency and secure such other records and documents as may be necessary and appropriate under the rules and regulations of the City.
10. The Agency will not discriminate on the basis of race, color, religion, sex (including pregnancy, sexual orientation, or gender identity), national origin, age, disability, and genetic information (including family medical history).
11. The parties agree that the City's contribution under this agreement is subject to the continued availability of funding and is contingent upon the City receiving sufficient

revenues during the budget year to provide the monies allocated.

12. In the event the Agency fails to comply with any provision of this MOU, the City may terminate the MOU upon giving thirty (30) days written notice to the Agency.
13. The City may, without cause, terminate the MOU upon giving thirty (30) days written notice to the Agency.
14. The Agency agrees to indemnify and hold harmless the City, its officers, and its employees from any act of or omission of the Agency, its employees, agency or servants, that results in the bodily injury, property damage, death of any party, or any other claims for damages growing out the performance of this MOU.
15. The parties agree that the provision of this MOU shall be construed according to the laws of the State of Mississippi.
16. The parties agree that the provisions of this MOU constitute their entire agreement, and no prior oral or written representations shall be effective and operate to amend, alter, or vary the terms of this MOU.
17. The parties agree that this MOU may not be modified except upon prior written consent and agreement of the parties.
18. The parties agree that any and all remedies available at law and equity may be asserted by the City in the event of default or breach and shall not be waived.

IN WITNESS WHEREOF, this Contract is executed by the parties hereto on this, the

_____ day of _____, 2023.

CITY OF JACKSON, MISSISSIPPI

BY: _____
Chokwe A. Lumumba, Mayor

ATTEST:

Angela Harris, Municipal Clerk

USA INTERNATIONAL BALLET

BY: _____
Director

MEMORANDUM OF UNDERSTANDING

WHEREAS, this Memorandum of Understanding (hereinafter referred to as "MOU") is made and entered into by and between the **CITY OF JACKSON, MISSISSIPPI**, hereinafter referred to as "City", and the **TEST-TAKING SOLUTION FOUNDATION** hereinafter referred to as the "Agency," whose address is 2104 Thousand Oak Drive, Jackson, Mississippi 39212; and

WHEREAS, Section 39-15-1 of the Mississippi Code of 1972, as amended, authorizes and empowers, in their discretion, to expend monies from the municipal general fund to match any other funds available for the purpose of supporting the development, promotion, and coordination of the arts in the municipality; and

WHEREAS, Section 21-19-65 of Mississippi Code of 1972, as amended, authorizes the governing authorities of this municipality the power to expend monies from the municipal general fund to match other funds for the purpose of supporting social and community service programs; and

WHEREAS, consistent with the provisions of Section 39-15-1 and Section 21-19-65 of the Mississippi Code of 1972, as amended, the governing authorities for the City of Jackson allocated monies in its budget for the 2022-2023 fiscal year to be expended for the promotion and development of the arts in the municipality and the support of social and community service programs; and

WHEREAS, the Department of Human and Cultural Services issued a Request for Proposals to solicit a response from art groups and other community organizations for art and cultural project that impact at least 350 people per project in the City of Jackson. The maximum award is \$10,000.00; and

WHEREAS, the governing authorities for the City of Jackson approved an Order authorizing the award of a matching grant, on a reimbursement basis, to Test-Taking Solution Foundation to provide support on June 17, 2023 for the Juneteenth Arts Celebration in the heart of Brookhollow Subdivision community within the City of Jackson; and

WHEREAS, the Jackson City Council awarded the payment of matching funds in the amount of Ten Thousand Dollars and No Cents (\$10,000.00); and

WHEREAS, it is the parties' intent to commit to writing those terms and provisions which shall govern their relationship and the use of the monies appropriated.

WITNESSETH:

NOW, THEREFORE, in consideration of the mutual benefits and advantages each to the other, the receipt and sufficiency of which are hereby acknowledged, the City and Test-Taking Solution Foundation agree as follows:

1. The Agency shall provide oversight and management for all activities for the provision for the June 17, 2023 Juneteenth Arts Celebration from 2:00 pm until 6:00 pm at the Test-Taking Solution Education & Research Center at 2104 Thousand Oaks Drive, Jackson, MS 39212. The project will be an educational community engagement event that offers an open mic with an emphasis on Juneteenth, for community to learn more

about this holiday and to share their creative art and talents.

2. The Agency shall provide the City with written documentation evidencing the matching funds when the request for reimbursement is submitted. Any final request for reimbursement must be submitted by the Agency on or before September 5, 2023. Any allocated funds not requested on or before September 5, 2023, will not be approved for payment. The receipt of the written documentation evidencing the matching funds is a condition precedent to receiving the matching or reimbursement funds allocated.
3. The Agency shall provide to the City reports on its activities, expenditure, and the availability of matching funds and as a condition precedent to receiving the funds allocated.
4. The Agency agrees to match funds contributed by the City with dollars from other funding sources consistent with the requirements of Section 39-15-1 and Section 21-19-65 of the Mississippi Code of 1972, as amended.
5. The Agency agrees to match funds contributed by the City with at least 50% from other funding sources consistent with the requirement of Section 39-15-1 of the Mississippi Code.
6. This MOU shall commence upon execution and end on September 30, 2023.
7. The City shall provide funds up to Ten Thousand Dollars and No Cents (\$10,000.00), to the Agency, on a reimbursement and matching funds basis, for performance of the services set forth and specified herein.
8. The Agency shall maintain all financial and programmatic records, documents and other evidence related to the expenditure of funds for a minimum of three (3) years. Records that must be maintained include, but shall not be limited to: bank statements showing the disbursement of the funds contributed by the City of Jackson, related invoice, and expense records. The form of such records and reports shall conform to generally accepted accounting practices, and shall sufficiently and properly reflect all direct and indirect costs of any nature expended in the performance of this MOU shall be utilized.
9. The City, or its authorize representative shall have the right, at any reasonable time, to examine the books and records of the Agency pertaining to the funds related to this MOU. Further, the Agency shall allow the City at any time, and from time to time, during reasonable business hours, to audit the books of the Agency and secure such other records and documents as may be necessary and appropriate under the rules and regulations of the City.
10. The Agency will not discriminate on the basis of race, color, religion, sex (including pregnancy, sexual orientation, or gender identity), national origin, age, disability, and genetic information (including family medical history).
11. The parties agree that the City's contribution under this agreement is subject to the

continued availability of funding and is contingent upon the City receiving sufficient revenues during the budget year to provide the monies allocated.

12. The City may, without cause, terminate the MOU upon giving thirty (30) days written notice to the Agency.
13. In the event the Agency fails to comply with any provision of this MOU, the City may terminate the MOU upon giving thirty (30) days written notice to the Agency.
14. The Agency agrees to indemnify and hold harmless the City, its officers, and its employees from any act of or omission of the Agency, its employees, agency or servants, that results in the bodily injury, property damage, death of any party, or any other claims for damages growing out the performance of this MOU.
15. The parties agree that the provision of this MOU shall be construed according to the laws of the State of Mississippi.
16. The parties agree that the provisions of this MOU constitute their entire agreement, and no prior oral or written representations shall be effective and operate to amend, alter, or vary the terms of this MOU.
17. The parties agree that this MOU may not be modified except upon prior written consent and agreement of the parties.
18. The parties agree that any and all remedies available at law and equity may be asserted by the City in the event of default or breach and shall not be waived.

IN WITNESS WHEREOF, this Contract is executed by the parties hereto on this, the

_____ day of _____, 2023.

CITY OF JACKSON, MISSISSIPPI

BY: _____
Chokwe A. Lumumba, Mayor

ATTEST:

Angela Harris, Municipal Clerk

TEST-TAKING SOLUTION FOUNDATION

BY: _____
Director

MEMORANDUM OF UNDERSTANDING

WHEREAS, this Memorandum of Understanding (hereinafter referred to as "MOU") is made and entered into by and between the **CITY OF JACKSON, MISSISSIPPI**, hereinafter referred to as "City", and the **SHOWTIME AT JACKSON** hereinafter referred to as the "Agency," with its principal place of business at 3733 Azalea Drive Jackson, Mississippi 39206; and

WHEREAS, Section 39-15-1 of the Mississippi Code of 1972, as amended, authorizes and empowers, in their discretion, to expend monies from the municipal general fund to match any other funds available for the purpose of supporting the development, promotion, and coordination of the arts in the municipality; and

WHEREAS, Section 21-19-65 of Mississippi Code of 1972, as amended, authorizes the governing authorities of this municipality the power to expend monies from the municipal general fund to match other funds for the purpose of supporting social and community service programs; and

WHEREAS, consistent with the provisions of Section 39-15-1 and Section 21-19-65 of the Mississippi Code of 1972, as amended, the governing authorities for the City of Jackson allocated monies in its budget for the 2022-2023 fiscal year to be expended for the promotion and development of the arts in the municipality and the support of social and community service programs; and

WHEREAS, the Department of Human and Cultural Services issued a Request for Proposals to solicit a response from art groups and other community organizations for art and cultural project that impact at least 350 people per project in the City of Jackson. The maximum award is \$10,000.00; and

WHEREAS, the governing authorities for the City of Jackson approved an Order authorizing the award of a matching grant, on a reimbursement basis, to Showtime at Jackson to provide support on May 1, 2023 – August 31, 2023 for the activities of the Celebratory Music and Arts Concert Event within the City of Jackson; and

WHEREAS, the Jackson City Council awarded the payment of matching funds in the amount of Ten Thousand Dollars and No Cents (\$10,000.00); and

WHEREAS, it is the parties' intent to commit to writing those terms and provisions which shall govern their relationship and the use of the monies appropriated.

WITNESSETH:

NOW, THEREFORE, in consideration of the mutual benefits and advantages each to the other, the receipt and sufficiency of which are hereby acknowledged, the City and Showtime at Jackson agree as follows:

1. The Agency shall provide oversight and management for all activities for the provision for the August 2023 (date to be announce) Celebratory Music and Art Concert Event which will impact the lives of 350 to 500 youths by engaging them in exclusive information sessions on music and arts education and industry related topics, then culminating with a Celebratory Music and Arts Concert.
2. The Agency shall provide the City with written documentation evidencing the matching funds when the request for reimbursement is submitted. Any final request for

reimbursement must be submitted by the Agency on or before September 5, 2023. Any allocated funds not requested on or before September 5, 2023, will not be approved for payment. The receipt of the written documentation evidencing the matching funds is a condition precedent to receiving the matching or reimbursement funds allocated

3. The Agency agrees to match funds contributed by the City with at least 50% from other funding sources consistent with the requirement of Section 39-15-1 of the Mississippi Code.
4. The Agency shall provide to the City reports on its activities, expenditure, and the availability of matching funds and as a condition precedent to receiving the funds allocated.
5. The Agency agrees to match funds contributed by the City with dollars from other funding sources consistent with the requirements of Section 39-15-1 and Section 21-19-65 of the Mississippi Code of 1972, as amended.
6. This MOU shall commence upon execution and end on September 30, 2023.
7. The City shall provide funds up to Ten Thousand Dollars and No Cents (\$10,000.00), to the Agency, on a reimbursement and matching funds basis, for performance of the services set forth and specified herein.
8. The Agency shall maintain all financial and programmatic records, documents and other evidence related to the expenditure of funds for a minimum of three (3) years. Records that must be maintained include, but shall not be limited to: bank statements showing the disbursement of the funds contributed by the City of Jackson, related invoice, and expense records. The form of such records and reports shall conform to generally accepted accounting practices, and shall sufficiently and properly reflect all direct and indirect costs of any nature expended in the performance of this MOU shall be utilized.
9. The City, or its authorize representative shall have the right, at any reasonable time, to examine the books and records of the Agency pertaining to the funds related to this MOU. Further, the Agency shall allow the City at any time, and from time to time, during reasonable business hours, to audit the books of the Agency and secure such other records and documents as may be necessary and appropriate under the rules and regulations of the City.
10. The Agency will not discriminate on the basis of race, color, religion, sex (including pregnancy, sexual orientation, or gender identity), national origin, age, disability, and genetic information (including family medical history).
11. The parties agree that the City's contribution under this agreement is subject to the continued availability of funding and is contingent upon the City receiving sufficient revenues during the budget year to provide the monies allocated.
12. The City may, without cause, terminate the MOU upon giving thirty (30) days written notice to the Agency.

13. In the event the Agency fails to comply with any provision of this MOU, the City may terminate the MOU upon giving thirty (30) days written notice to the Agency.
14. The Agency agrees to indemnify and hold harmless the City, its officers, and its employees from any act of or omission of the Agency, its employees, agency or servants, that results in the bodily injury, property damage, death of any party, or any other claims for damages growing out the performance of this MOU.
15. The parties agree that the provision of this MOU shall be construed according to the laws of the State of Mississippi.
16. The parties agree that the provisions of this MOU constitute their entire agreement, and no prior oral or written representations shall be effective and operate to amend, alter, or vary the terms of this MOU.
17. The parties agree that this MOU may not be modified except upon prior written consent and agreement of the parties.
18. The parties agree that any and all remedies available at law and equity may be asserted by the City in the event of default or breach and shall not be waived.

IN WITNESS WHEREOF, this Contract is executed by the parties hereto on this, the

_____ day of _____, 2023.

CITY OF JACKSON, MISSISSIPPI

BY: _____
Chokwe A. Lumumba, Mayor

ATTEST:

Angela Harris, Municipal Clerk

SHOWTIME AT JACKSON

BY: _____
Director

Office of the City Attorney

455 East Capitol Street
Post Office Box 2779
Jackson, Mississippi 39207-2779
Telephone: (601) 960-1799
Facsimile: (601) 960-1756

OFFICE OF THE CITY ATTORNEY

This **ORDER AUTHORIZING THE CONTRIBUTION OF MATCHING FUNDS TO VARIOUS ORGANIZATIONS FOR THE PURPOSE OF SUPPORTING THE DEVELOPMENT OF THE ARTS OR SOCIAL AND COMMUNITY SERVICE PROGRAMS AND AUTHORIZING THE MAYOR TO EXECUTE CONTRACTS WITH THE ENTITIES RECEIVING MATCHING FUNDS** is legally sufficient for placement in NOVUS Agenda.

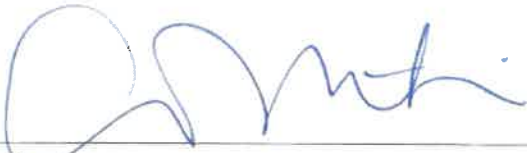

Catoria Martin, City Attorney

Sondra Moncure, Deputy City Attorney *SM*

5/1/23
Date

OFFICE OF THE CITY ATTORNEY
A.M. 5/1/23

27

OFFICE OF THE CITY ATTORNEY
JPL
5/22/23

ORDER AUTHORIZING THE MAYOR TO ENTER INTO AN AGREEMENT WITH CREATIVE RESEARCH SOLUTIONS (CRS) TO SERVE AS CONSULTANT FOR THE CITY OF JACKSON TO CONDUCT EVALUATION ASSESSMENTS FOR THE W.K. KELLOGG FOUNDATION-FUNDED PROJECT, ECONOMIC PATHWAYS TO HUMAN DIGNITY: BUILDING OCCUPATIONAL OPPORTUNITIES & ECONOMIC GROWTH (EPHD)

WHEREAS, the W.K. Kellogg Foundation awarded Economic Pathways to Human Dignity: Building Occupational Opportunities & Economic Growth funds to the City of Jackson to support its goals to increase employment, economic development, city and regional competitiveness, job creation, and employer engagement allowing the citizenry access to tools that will help them traverse pathways to self-sufficiency; and

WHEREAS, on April 30, 2019, the City Council authorized the Mayor to accept a \$1,895,000.00 grant from W. K. Kellogg Foundation to be allocated over three years for the development of the proposal entitled Employment Pathways to Human Dignity (EPHD); and

WHEREAS, on August 4, 2020, the City Council authorized the execution of a contractual agreement with Creative Research Solutions (CRS) whereby CRS served as a consultant under the EPHD project and conducted evaluation services of the project, which included developing the infrastructure and/or a rubric for data collection and analysis activities such as background research, monitoring plan technical assistance, and focus group(s); and

WHEREAS, the City of Jackson agreed to compensate CRS as an independent contractor in a total amount not to exceed \$120,000.00 in fees and not to exceed \$2,500.00 in travel-related expenses during the grant period of August 1, 2020 through March 31, 2022; and

WHEREAS, on August 16, 2022, the City Council approved an Order ratifying the submission of a request for an eighteen-month grant extension to the W.K. Kellogg Foundation that extended the grant period to September 30, 2023 for the development of the proposal entitled Employment Pathways to Human Dignity (EPHD); and

WHEREAS, in light of the grant extension, the Chief Administrative Officer recommends that the City Council authorize the Mayor to enter into an independent contractor relationship with CRS to serve as a Consultant from April 11, 2023 to September 30, 2023; and

WHEREAS, the scope of work includes (1) conducting background research and logic model and evaluation plan refinement; (2) data collection and analysis with surveys and focus groups; (3) synthesizing and triangulating the data and findings from surveys, focus groups, observations, and monitoring tools; (4) conducting a virtual sensemaking session; and (5) developing an evaluation report; and

WHEREAS, either party may terminate the agreement at any time upon delivery of written notice to the other party no less than 14 days prior to the intended termination date, provided, however, that in such event, the terminating party agrees to act in good faith to assist

the other party with the orderly wind-down of such party's work on any active and on-going assignment; and

WHEREAS, the parties agree that the legal relationship between Creative Research Solutions and the City of Jackson is strictly an independent contractor relationship. Nothing contained in the agreement shall be deemed or construed to create a joint venture, agency, partnership, or employer-contractor relationship between the Parties. Neither party shall have the power to bind the other Party in any manner. Additionally, the City of Jackson shall have no obligation to CRS with respect to the provision of any benefits (insurance, retirement, or the like), nor shall the City of Jackson have any responsibility for the payment of any taxes, fees, dues, or memberships, workers' compensation premiums, or the like, which are the sole responsibility of Creative Research Solutions; and

WHEREAS, the City of Jackson will compensate CRS for its services as a consultant in an amount not to exceed \$11,816.74 per month for 6 months, totaling an amount not to exceed \$70,900.44.

IT IS THEREFORE ORDERED that the Mayor be authorized to enter into an agreement with Creative Research Solutions to provide evaluation services on the W.K. Kellogg Foundation-funded project Employment Pathways to Human Dignity (EPHD) from April 11, 2023 through September 30, 2023.

IT IS FURTHER ORDERED that upon the submission of invoices monthly to the City of Jackson, Creative Research Solutions shall be paid an amount not to exceed \$11,816.74 per month from grant funds for conducting EPHD evaluation services.

Item# _____
Agenda Date: April 25, 2023
By: (Dotson, Lumumba)

CITY COUNCIL AGENDA ITEM 10 POINT DATA SHEET

DATE: April 11, 2023

1.	Brief Description/Purpose	ORDER AUTHORIZING THE MAYOR TO ENTER INTO AN AGREEMENT WITH CREATIVE RESEARCH SOLUTIONS (CRS) TO SERVE AS CONSULTANT FOR THE CITY OF JACKSON TO CONDUCT EVALUATION ASSESSMENTS FOR THE W.K. KELLOGG FOUNDATION-FUNDED PROJECT, ECONOMIC PATHWAYS TO HUMAN DIGNITY: BUILDING OCCUPATIONAL OPPORTUNITIES & ECONOMIC GROWTH (EPHD)								
2.	Public Policy Initiative 1. Youth & Education 2. Crime Prevention 3. Changes in City Government 4. Neighborhood Enhancement 5. Economic Development 6. Infrastructure and Transportation 7. Quality of Life	5. Economic Development								
3.	Who will be affected	City of Jackson								
4.	Benefits	Data informed decision-making for City leadership								
5.	Schedule (beginning date)	Upon Approval								
6.	Location: ▪ WARD ▪ CITYWIDE (yes or no) (area) ▪ Project limits if applicable	Citywide								
7.	<input type="checkbox"/> Action implemented by: <input type="checkbox"/> ▪ City Department <input type="checkbox"/> ▪ Consultant	CAO								
8.	COST	\$70,900.43								
9.	<input type="checkbox"/> Source of Funding <input type="checkbox"/> ▪ General Fund <input type="checkbox"/> ▪ Grant <input type="checkbox"/> ▪ Bond <input type="checkbox"/> ▪ Other	W.K.Kellogg Foundation Grant <i>Economic Pathways to Human Dignity</i>								
10.	EBO participation	ABE	_____ %	WAIVER	yes	___	no	___	N/A	<u>X</u>
		AABE	_____ %	WAIVER	yes	___	no	___	N/A	<u>X</u>
		WBE	_____ %	WAIVER	yes	___	no	___	N/A	<u>X</u>
		HBE	_____ %	WAIVER	yes	___	no	___	N/A	<u>X</u>
		NABE	_____ %	WAIVER	yes	___	no	___	N/A	<u>X</u>

MEMORANDUM



TO: Mayor Chokwe Lumumba

FROM: Louis Wright, City Administrative Officer

DATE: February 16, 2023

RE: ORDER AUTHORIZING THE MAYOR TO ENTER INTO AN AGREEMENT WITH CREATIVE RESEARCH SOLUTIONS (CRS) TO SERVE AS CONSULTANT FOR THE CITY OF JACKSON TO CONDUCT EVALUATION ASSESSMENTS FOR THE W. K. KELLOGG FOUNDATION-FUNDED PROJECT, ECONOMIC PATHWAYS TO HUMAN DIGNITY: BUILDING OCCUPATIONAL OPPORTUNITIES & ECONOMIC GROWTH (EPHD)

The agenda item which accompanies this memo requests that the City Council authorize the agreement with Creative Research Solutions (CRS) to serve as a Contractor to conduct background research and logic model and evaluation plan refinement; data collection and analysis with surveys and focus groups, synthesize and triangulate the data/findings from surveys, focus groups, observations, and monitoring tools; conduct a virtual sensemaking session; and develop an evaluation report. The City of Jackson will compensate CRS \$70,900.43 for the period February 28, 2023 – September 30, 2023 for its services as a consultant. Funds will still be paid by the W. K. Kellogg Foundation-funded Project, *Economic Pathways to Human Dignity: Building Occupational Opportunities & Economic Growth*.



A Partner With Communities Where Children Come First

One Michigan Avenue East
Battle Creek, MI 49017-4012

MAIN 269.968.1611
FAX 269.968.0413

wkkf.org

June 28, 2022

Jhai Keeton
Deputy Director of Economic Development
City of Jackson
200 S. President St.
Jackson, Mississippi 39205

RE: P-P0131760-2019 (Please refer to this number when writing to the W.K. Kellogg Foundation about this project.)

Dear Jhai Keeton:

The agreement dated April 29, 2019 ("Agreement"), between the W.K. Kellogg Foundation ("Foundation") and City of Jackson ("Grantee") is hereby amended as stated below. The purpose of the grant is to increase employment opportunities for low-income families of color through a stratified framework of workforce and economic development, job creation and employer engagement to achieve family economic security and regional prosperity. This letter of amendment ("Amendment") is based on the amendment request reference number P-P0131760-2019 ("Amendment Request"), submitted to the Foundation via its grantee portal.

This Amendment provides an extension of the Grant Period through September 30, 2023. This amendment does not in any way increase the Foundation's commitment. As a reminder, reports for the period ending March 31, 2022, are due now. The budget for the remaining Reporting Period of April 1, 2022, through September 30, 2023, will be established after financial reporting has been submitted and approved by the Foundation program officer.

This Amendment may be executed in counterparts, and each counterpart will be deemed an original and all of which taken together will constitute one signed agreement between the parties. Such counterparts may be delivered in electronic format, including by facsimile, email or other transmission method, and such electronic delivery of an executed counterpart signature page to this Amendment shall be as effective as physical delivery of a manually executed counterpart. To the fullest extent permitted by law, any electronic signature to this Amendment shall have the same legal validity and enforceability as a manual signature, and the parties hereby waive any objection thereto. Minor variations in the form of the signature page, including footers from earlier versions of this Amendment, shall be disregarded in determining a party's intent or the effectiveness of such signature.

This Amendment will be governed by and construed in accordance with the governing laws set forth in the Agreement. All other terms and conditions contained in the Agreement continue to apply for the life of the grant. All capitalized terms used but not defined in this Amendment shall have the meaning given in the Agreement.

If you have any questions about the terms or conditions of this Amendment, please contact Grant Services at (269) 969-2330 or grantservices@wkkf.org. On behalf of the Foundation, I extend every good wish for the continued success of this effort.

Sincerely,

A handwritten signature in black ink, appearing to read "Emily Sheffieck". The signature is written in a cursive, flowing style.

Emily Sheffieck
Grant Analyst

**Creative Research Solutions, Consultant Engagement,
Non-Solicitation and Confidentiality Agreement
with the City of Jackson**

This Engagement, Non-Solicitation and Confidentiality Agreement (the "Agreement"), is made between the City of Jackson ("COJ") and **Creative Research Solutions, 4002 Hwy 78, Ste 530-240 Snellville, Georgia 30039** (the "Consultant").

WHEREAS, COJ and the Consultant herewith agree to enter into an independent contractor relationship whereby the Consultant will provide services as the subcontractor for the W.K. Kellogg project *Economic Pathways to Human Dignity, Building Occupational Opportunities and Economic Growth through a Framework of Equity and Inclusion* that was recently awarded to COJ, in accordance with the terms, conditions and compensation mutually agreed upon by both parties.

Scope of Work. The Consultant will conduct background research and logic model and evaluation plan refinement; data collection and analysis with surveys and focus groups, synthesize and triangulate the data/findings from surveys, focus groups, observations, and monitoring tools; conduct a virtual sensemaking session; and develop an evaluation report. W.K. Kellogg has designated Creative Research Solutions as the Consultant to fulfil this scope of work.

Term/Termination. This Agreement commenced upon execution and shall continue uninterrupted until September 30, 2023. Either party may terminate this Agreement at any time upon the delivery of written notice to the other party no less than 14 days prior to the intended termination date, provided however that in such event, the terminating Party agrees to act in good faith to assist the other party with the orderly wind-down of such party's work on any active and on-going assignment.

Compensation. For the duties and obligations to be performed by Consultant pursuant to this Agreement, COJ agrees to compensate the Consultant at the rate set forth by the W.K. Kellogg for the position the Consultant has agreed to for the grant period of February 28, 2023, and September 30, 2023. The COJ agrees to compensate Consultant in an amount not to exceed Ten Thousand and One Hundred Twenty-Eight Dollars and Sixty-Three Cents (\$10,128.63) a month for seven (7) months totaling an amount not to exceed Seventy Thousand Nine Hundred and Forty-Three Cents (\$70,900.43). Consultant shall not perform any additional services for the COJ that is not authorized by W.K. Kellogg project *Economic Pathways to Human Dignity, Building Occupational Opportunities and Economic Growth through a Framework of Equity*. Consultant will not receive any funds from the W.K. Kellogg project *Economic Pathways to Human Dignity, Building Occupational Opportunities and Economic Growth through a Framework of Equity* for services outside the Scope of Work.

Independent Contractor. The parties agree that the legal relationship of Consultant and COJ is strictly an independent contractor relationship. Nothing contained in this Agreement shall be deemed or construed to create a joint venture, agency, partnership or Employer-Contractor relationship between the Parties. Neither Party shall have the power to bind the other Party in any manner. Additionally, the COJ shall have no obligation to Consultant with

respect to the provision of any benefits (insurance, retirement or the like) nor shall the COJ have any responsibility for the payment of any taxes, fees, dues or memberships, workers' compensation premiums, or the like, which are the sole responsibility of the Consultant.

Confidentiality and Treatment of Information. Consultant agrees that it will not improperly use or disclose any confidential information obtained in connection with activities in which it has been engaged under this Agreement. Consultant understands that it has both a professional and moral obligation to keep such Information confidential and at all times to maintain such Information in a safe and secure manner. Contractor agrees to hold such Information in the strictest confidence and use such Information only as and to the extent necessary and appropriate in connection with duties performed hereunder.

Governing Law. This Agreement shall be controlled, construed and enforced under the laws of the State of Mississippi without regard to principles governing conflicts of laws.

Language. The section headings contained herein are inserted only as a matter of convenience and reference and in no way define, limit or describe the scope of this Agreement or the intent of any provision hereof. The parties agree that each party has reviewed this Agreement and has had the opportunity to have legal counsel review it.

This Engagement, Non-Solicitation, and Confidentiality Agreement will be fully executed the

signatures of the parties identified herewith on this _____ day of _____, 20__.

Creative Research Solutions

Mayor Chokwe Antar Lumumba

Office of the City Attorney

455 East Capitol Street
Post Office Box 2779
Jackson, Mississippi 39207-2779
Telephone: (601) 960-1799
Facsimile: (601) 960-1756

OFFICE OF THE CITY ATTORNEY

This ORDER AUTHORIZING THE MAYOR TO ENTER INTO AN AGREEMENT WITH CREATIVE RESEARCH SOLUTIONS (CRS) TO SERVE AS CONSULTANT FOR THE CITY OF JACKSON TO CONDUCT EVALUATION ASSESSMENTS FOR THE W.K. KELLOGG FOUNDATION-FUNDED PROJECT, ECONOMIC PATHWAYS TO HUMAN DIGNITY: BUILDING OCCUPATIONAL OPPORTUNITIES & ECONOMIC GROWTH (EPHD) is legally sufficient for placement in NOVUS Agenda.

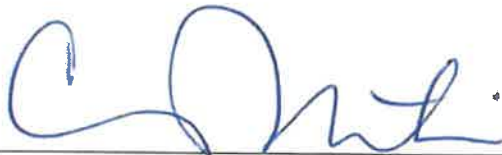

Catoria Martin, City Attorney

Kristie Metcalfe, Deputy City Attorney



4/19/23
Date

OFFICE OF THE CITY ATTORNEY
4/19/23

28

OFFICE OF THE CITY ATTORNEY
JST/2/23

ORDER RATIFYING AND AUTHORIZING THE MAYOR TO ENTER INTO AN AGREEMENT WITH SERVICEMASTER COMMERCIAL CLEANING OF JACKSON TO PROVIDE JANITORIAL SERVICES AND SUPPLIES FOR THE ADMINISTRATION BUILDING AND CUSTOMER SERVICE OFFICE (UNION STATION) OF THE CITY OF JACKSON'S PUBLIC TRANSPORTATION SYSTEM (JTRAN) COMMENCING MAY 1, 2023

WHEREAS, the City of Jackson (City) has determined that is in the City's best interest to seek a professional company to provide janitorial services and supplies for Administration Building and Customer Service Office (Union Station) of the City of Jackson's Public Transportation System (JTRAN); and

WHEREAS, the City issued a Request for Proposal (RFP) on February 24, 2023 for Janitorial Services and Supplies for the Administration Building and Customer Service Office (Union Station) of the City of Jackson's Public Transportation System (JTRAN) and received four responses; and

WHEREAS, staff within the transit services division reviewed the procedures used by the State of Mississippi and Federal Transit Administration (FTA) to award the contract to ServiceMaster Commercial Cleaning of Jackson for the next five (5) years commencing on May 1, 2023 through April 30, 2028 with two one-year options to be exercised at the future discretion of City Council; and

WHEREAS, based on the best value procurement policy, ServiceMaster Commercial Cleaning of Jackson has been determined to provide the janitorial services and supplies; and

WHEREAS, the City shall pay ServiceMaster Commercial an amount not to exceed one hundred seventy-three thousand seven hundred sixty dollars (\$173,760.00) from the FY2023 Transit budget; and

WHEREAS, monies received from the Federal Transit Administration in the amount of one hundred thirty-nine thousand eight dollars (\$139,008.00) will be used to fund the procurement described; and

WHEREAS, the sum of thirty-four thousand seven hundred fifty-two dollars (\$34,752.00) is not covered by federal funding and must be matched from the City local fund; and

WHEREAS, the local match is included in the Transit Division's budget for FY2023;

IT IS THEREFORE ORDERED that the Mayor is authorized to enter into an Agreement with ServiceMaster Commercial Cleaning of Jackson to provide Janitorial Services and Supplies of the public transportation system (JTRAN) for a term beginning on May 1, 2023 and ending on April 30, 2028.

IT IS HEREBY ORDERED that a sum not to exceed one hundred seventy-three thousand seven hundred sixty dollars (\$173,760.00) may be expended for the procurement with the understanding that federal monies in the amount of one hundred thirty-nine thousand eight dollars (\$139,008.00) will be used for the procurement and a local match not exceeding thirty-

No.
28

four thousand seven hundred fifty-two dollars (\$34,752.00) will also be used from the FY2023 Transit Division budget.

Item# _____
Agenda Date: May 9, 2023
By: (Dotson, Lumumba)

CITY COUNCIL AGENDA ITEM 10 POINT DATA SHEET DATE: 4/25/2023

POINTS		COMMENTS
1.	Brief Description/Purpose	ORDER AUTHORIZING THE MAYOR TO ENTER INTO AN AGREEMENT WITH SERVICEMASTER COMMERCIAL CLEANING OF JACKSON TO PROVIDE JANITORIAL SERVICES AND SUPPLIES FOR THE ADMINISTRATION BUILDING AND CUSTOMER SERVICE OFFICE (UNION STATION) OF THE CITY OF JACKSON'S PUBLIC TRANSPORTATION SYSTEM (JTRAN) COMMENCING MAY 1, 2023
2.	Public Policy Initiative 1. Youth & Education 2. Crime Prevention 3. Changes in City Government 4. Neighborhood Enhancement 5. Economic Development 6. Infrastructure & Transportation 7. Quality of Life	6. Infrastructure & Transportation.
3.	Who will be affected	All citizens and visitors
4.	Benefits	All citizens and visitors
5.	Schedule (beginning date)	May 1, 2023
6.	Location:	Department of Planning & Development/Office of Transportation/All wards
7.	Action implemented by: City Department	Department of Planning & Development Office of Transportation
8.	COST	\$173,760.00
9.	Source of Funding General Fund x Grant x Bond Other	Account# 187.565.20.6213 \$24,000.00 187.565.10.6461 \$131,760.00 187.565.50.6461 \$18,000.00 Grant# : \$139,008.00 MS-2021.009.00/Ali 11.79.00: General Fund: \$34,752.00
10.	EBO participation	ABE ___% WAIVER yes ___ no ___ N/A <u>X</u> AABE ___% WAIVER yes ___ no ___ N/A <u>X</u> WBE ___% WAIVER yes ___ no ___ N/A <u>X</u> HBE ___% WAIVER yes ___ no ___ N/A <u>X</u> NABE ___% WAIVER yes ___ no ___ N/A <u>X</u>

MEMORANDUM

TO: Chokwe A. Lumumba, Mayor

THRU: Chloe Dotson, Director
Planning & Development

FROM: Christine Welch, Deputy Director *ofw*
Office of Transportation

DATE: April 12, 2023

RE: Agenda Item for April 25, 2023 City Council Meeting

The attached agenda item is an order authorizing an agreement with ServiceMaster Commercial Cleaning of Jackson to provide Janitorial Services and Supplies for the Administration Building and Customer Service Office (Union Station) of the City of Jackson's Public Transportation System (JATRAN).

Previously, the Operations' Contractor provided these services for the Administration Building with very minimum duties (emptying trash/spot cleaning restrooms/requested mopping & vacuuming) and none to the Customer Service Office (Union Station). Due to the shortage in Care Maintenance, additional work to these locations were contracted out; therefore, the Office of Transportation feels contracting these services would offer a better solution to maintaining these locations.

It is the recommendation of this department that this request for janitorial services and supplies be approved. If you have any questions, please call Christine Welch, Deputy Director, Department of Planning and Development/Office of Transportation at (601) 960-1909 or e-mail cwelch@city.jackson.ms.us.

Office of the City Attorney

455 East Capitol Street
Post Office Box 2779
Jackson, Mississippi 39207-2779
Telephone (601) 960-1799
Facsimile (601) 960-1756

OFFICE OF THE CITY ATTORNEY

This ORDER RATIFYING AND AUTHORIZING THE MAYOR TO ENTER INTO AN AGREEMENT WITH SERVICEMASTER COMMERCIAL CLEANING OF JACKSON TO PROVIDE JANITORIAL SERVICES AND SUPPLIES FOR THE ADMINISTRATION BUILDING AND CUSTOMER SERVICE OFFICE (UNION STATION) OF THE CITY OF JACKSON'S PUBLIC TRANSPORTATION SYSTEM (JTRAN) COMMENCING MAY 1, 2023 is legally sufficient for placement in NOVUS Agenda.



Catoria Martin, City Attorney

Kristie Metcalfe, Deputy City Attorney



5/3/23
Date

OFFICE OF THE CITY ATTORNEY
5/3/23

29

OFFICE OF THE CITY ATTORNEY
4/26/23

ORDER AUTHORIZING THE EXECUTION OF A MEMORANDUM OF UNDERSTANDING BETWEEN THE CITY OF JACKSON AND HOPE ENTERPRISE CORPORATION TO PARTICIPATE IN THE DIVERSITY PILOT PROGRAM

WHEREAS, the City of Jackson's Office of Economic Development (OED) requires technical assistance to help design and implement local economic inclusion strategies to increase access and procurement opportunities for businesses of color; and

WHEREAS, the OED has a variety of resources available to assist minority business owners in increasing their capacity through the provision of technical assistance; and

WHEREAS, the Hope Enterprise Corporation (HEC)'s Diversity Pilot Program ("Pilot") is available to assist the City of Jackson by laying the groundwork to prepare small businesses owned by people of color to compete for supplier opportunities; and

WHEREAS, the Pilot has three goals: (1) to provide technical assistance and non-dilutive capital to small businesses of color to aid in growing and bettering their position for contracting and procurement opportunities, (2) to promote equitable procurement practices among institutional buyers participating in the Pilot, and (3) to produce and distribute the Supplier Diversification Strategy Guide to share lessons learned and shape future expansion or replication of the Pilot; and

WHEREAS, the City will participate as a "buyer" by identifying ways to include business diversity in supplier contracts, support technical assistance providers for the Pilot's small business participants, and engage to identify and understand the challenges facing small businesses in accessing procurement opportunities including potential ways to make procurement policies and procedures more inclusive; and

WHEREAS, the City of Jackson finds it reasonable to partner with HEC with the Diversity Pilot Program to enhance the effectiveness of the OED and how we provide contracting and procurement opportunities to our business community.

NOW, THEREFORE, IT IS HEREBY ORDERED that the City of Jackson is authorized to enter into a Memorandum of Understanding (MOU) with HEC.

Item No.: 29
Date: May 23, 2023
By: (Dotson, Lumumba)

CITY COUNCIL AGENDA ITEM 10 POINT DATA SHEET

DATE: 4/7/2023

P O I N T S		C O M M E N T S			
1.	Brief Description	ORDER AUTHORIZING THE EXECUTION OF A MEMORANDUM OF UNDERSTANDING BETWEEN THE CITY OF JACKSON AND HOPE ENTERPRISE CORPORATION TO PARTICIPATE IN THE DIVERSITY PILOT PROGRAM			
2.	Purpose	To increase access and procurement opportunities for businesses of color			
3.	Who will be affected	Existing and potential small businesses in the City of Jackson			
4.	Benefits	Provide technical assistance to contracting and procurement opportunities for existing businesses of color in the City of Jackson			
5.	Schedule (beginning date)	Upon approval			
6.	Location: <ul style="list-style-type: none"> ▪ WARD ▪ CITYWIDE (yes or no) (area) ▪ Project limits if applicable 	citywide			
7.	Action implemented by: <ul style="list-style-type: none"> ▪ City Department ▪ Consultant 	Department of Planning & Development			
8.	COST	\$0			
9.	Source of Funding <ul style="list-style-type: none"> ▪ General Fund ▪ Grant ▪ Bond ▪ Other 	<input type="checkbox"/> <input type="checkbox"/> <input type="checkbox"/> <input type="checkbox"/>			
1	EBO participation See attached sheets from Vendors	ABE _____ %	WAIVER	yes ___ no ___	N/A <u> X </u>
		AABE _____ %	WAIVER	yes ___ no ___	N/A <u> X </u>
		WBE _____ %	WAIVER	yes ___ no ___	N/A <u> X </u>
		HBE _____ %	WAIVER	yes ___ no ___	N/A <u> X </u>
		NABE _____ %	WAIVER	yes ___ no ___	N/A <u> X </u>

Department of Planning and Development



200 South President Street
Post Office Box 17
Jackson, Mississippi 39205-0017

TO: Mayor Chokwe Lumumba

FROM: Chloe Dotson BUPD. MURP., Director
Department of Planning and Development

DATE: April 7, 2023

RE: ORDER AUTHORIZING THE EXECUTION OF A MEMORANDUM OF UNDERSTANDING BETWEEN THE CITY OF JACKSON AND HOPE ENTERPRISE CORPORATION TO PARTICIPATE IN THE DIVERSITY PILOT PROGRAM

In an effort to increase the levels of minority business participation in the City of Jackson and to increase the resources and technical assistance to assist minority businesses in procurement opportunities, the Office of Economic Development (OED) recommends that the City enters into a Memorandum of Understanding (MOU) with the Hope Enterprise Corporation. As a result of entering into the MOU, a strategic partnership will be created, which allows the City to participate in the Diversity Pilot Program to increase access and procurement opportunities for businesses of color, which will increase the effectiveness of the OED..

**MEMORANDUM OF UNDERSTANDING
BETWEEN HOPE ENTERPRISE CORPORATION
AND THE CITY OF JACKSON, MS**

1. Parties.

This Memorandum of Understanding (hereinafter referred to as "MOU") is made and entered into by and between Hope Enterprise Corporation (hereinafter referred to as "HEC") and The City of Jackson (hereinafter referred to as "City of Jackson")

2. Purpose, Background, Vision, and Activities.

The purpose of this MOU for the Hope Supplier Diversity Pilot (hereinafter referred to as the "Pilot"), a collaboration with HEC and The City of Jackson to increase access and procurement opportunities for businesses of color.

Background

The Pilot will lay the groundwork to prepare small businesses owned by people of color to compete for supplier opportunities, in addition to potentially influencing institutional contracting and procurement policies to become more inclusive of diverse suppliers. Notable activities of the Pilot include the provision of technical assistance to the participating small businesses to increase their chances of successfully winning contracts, as well as the provision of capital to these participants by HEC in the form of forgivable, zero-interest small loans and other non-dilutive capital. The Pilot will result in the production of a Supplier Diversification Strategy Guide (hereinafter referred to as the "Guide") to share lessons learned and shape future expansion or replication of the program. While activities will be focused on 20 businesses owned by people of color and a select number of institutions, the ultimate vision is for the Pilot's impact to reverberate much more widely, particularly through the Guide's reach. This vision includes increasing access, awarding, and successful management of procurement opportunities to diverse small businesses, both because of recommendations to support diverse small businesses' capacity and growth and from responsive institutional policy changes.

As part of the Diversity Pilot Program, HEC solicited participation of the governmental entities in the two municipalities included in the Pilot. The Mayors of the City of Jackson and the City of New Orleans have agreed to include their City's Procurement Departments to participate as Municipal Anchor Partners for the Diversity Pilot Program. The responsibilities of a Municipal Anchor Partner for the Diversity Pilot Program are identified within this Memorandum of Understanding.

Project Vision and Activities

Overall, the Pilot will:

1. Provide technical assistance and non-dilutive capital to 20 small businesses led by people of color with goals to grow and better position these businesses for contracting and procurement opportunities;
2. Promote equitable procurement policies among institutional buyers participating in the Pilot; and
3. Produce and distribute the Guide to share lessons learned and shape future expansion or replication of the Pilot by HEC.

3. Term of MOU

This MOU is effective upon the day and date last signed and executed by the duly authorized representatives of the parties to this MOU and shall remain in full force and effect until and unless terminated by either party upon thirty (30) days written notice to the other party or other mutually agreed upon terms. The notice must be delivered by certified mail, return receipt requested, or in person, with written proof of delivery.

4. Responsibilities of The City of Jackson

- A. Participate as a Municipal partner.
- B. Participate as a “buyer” interested in identifying ways to include business diversity in your supplier contracts.
- C. Partner to participate in recruiting small business participants to the Pilot Program that are interested and fit the following criteria: businesses with less than \$2,000,000 in annual receipts and that are majority owned by people of color (this is indicated by at least 51% ownership by a person or persons who are Asian, Black, Hispanic, and/or Native American).
- D. Support technical assistance providers for the Pilot Program’s small business participants.
- E. Designate a dedicated staff member as partner administrator for this pilot.
- F. Agree to engage with consultant contracted with HEC specifically for this initiative.
- G. Engage HEC and its consultant to better understand the challenges facing small businesses, identified as diverse, in accessing procurement opportunities including potential ways to make procurement policies and procedures more inclusive.
- H. Agree to consider implementing and/or enhancing equitable procurement policies.
- I. Identify level of inclusion of participation in the Pilot Program; i.e. designated City departments or across the entirety of City government.
- J. Based on the identified level of ‘participation inclusion’ as a Municipal partner, provide consultant with report including -
Total supplier spend, total supplier spend with minority businesses, and total supplier spend specific to Pilot Program’s participating small businesses.
- K. Include information about HEC in newsletters, emails, event announcements or other communications as appropriate.
- L. Participate in bi-weekly or monthly meetings with HEC and consulting partners.

5. Responsibilities of HEC

- A. HEC will administer the program for two municipalities including the City of Jackson, MS, and the City of New Orleans, LA, and three HBCUs: Jackson State University, Tugaloo College and Xavier University of Louisiana.
- B. Provide marketing and standard language for internal and external communication.
- C. HEC will provide financing to all 20 participants in the form of \$10,000 forgivable loans and will also explore other non-dilutive capital with participants as appropriate.
- D. Serve as the Pilot coordinator.
- E. HEC will work with institutional buyers to understand challenges for diverse businesses to access procurement opportunities and potential ways to make procurement policies and procedures more inclusive.
- F. HEC will work with contractor to document and disseminate lessons learned.
- G. HEC will engage other technical assistance partners to deliver free technical assistance to Pilot Program’s 20 participating diverse small businesses.
- H. HEC will track, measure, and evaluate the progress of the Pilot.
- I. HEC will engage a consultant.

6. General Provisions

- A. **Amendments.** Either Party may request changes to this MOU. Any changes, modifications, revisions, or amendments to this MOU, which are mutually agreed upon by and between the Parties to this MOU, shall be incorporated by written instrument and effective when executed and signed by all Parties to this MOU.

- B. **Applicable Law.** The construction, interpretation and enforcement of this MOU shall be subject to all applicable federal and/or state laws, rules, and regulations and construed in accordance with the laws of the State of Mississippi.
- C. **Severability.** Should any portion of this MOU be judicially determined to be illegal or unenforceable, the remainder of the MOU shall continue in full force and effect, and party may renegotiate the terms affected by the severance.
- D. **Notice.** Any notice required or permitted to be given under this Memorandum of Understanding shall be in writing and sent by Certified Mail, Return Receipt Requested, to the party to whom notice should be given at the address set forth below:

HEC: William Bynum
Chief Executive Officer
4 Old River Place, Ste A
Jackson, MS 39202

7. **Entirety of Agreement**

This MOU and its attachments represent the entire agreement between the Parties and supersedes all prior negotiations, representations, and agreements, whether written or oral.

8. **Signatures**

In witness whereof, the Parties to this MOU through their duly authorized representatives have executed this MOU on the days and dates set out below, and certify that they have read, understood, and agreed to the terms and conditions of this MOU as set forth herein. The effective date of this MOU is the date of the signature last affixed to this page.

HOPE ENTERPRISE CORPORATION

William Bynum
Chief Executive Officer
HCU Federal Credit Union

Date

THE CITY OF JACKSON

Chokwe Antar Lumumba, Esq
Mayor of Jackson, Mississippi

Date

Office of the City Attorney

455 East Capitol Street
Post Office Box 2779
Jackson, Mississippi 39207-2779
Telephone: (601) 960-1799
Facsimile: (601) 960-1756

OFFICE OF THE CITY ATTORNEY

This ORDER AUTHORIZING THE EXECUTION OF A MEMORANDUM OF UNDERSTANDING BETWEEN THE CITY OF JACKSON AND HOPE ENTERPRISE CORPORATION TO PARTICIPATE IN THE DIVERSITY PILOT PROGRAM is legally sufficient for placement in NOVUS Agenda.



Catoria Martin, *City Attorney*

Kristie Metcalfe, *Deputy City Attorney*



4/28/23
Date

APR 28 2023
OFFICE OF THE CITY ATTORNEY

30

ORDER DECLARING PARCEL NUMBER 112-1 SURPLUS PROPERTY AND AUTHORIZING THE MAYOR TO EXECUTE THE DEED OF CONVEYANCE AND OTHER DOCUMENTS NECESSARY TO DONATE SAID PROPERTY TO JACKSON RESOURCE CENTER FOR THE DEVELOPMENT OF A TRANSITIONAL HOUSING CENTER

OFFICE OF THE ATTORNEY GENERAL
5/1/23

WHEREAS, the City of Jackson owns certain real property and any improvements thereon located at 300 Capers Street. The real property is that same property recorded in the Office of the Chancery Clerk of Hinds County in Book 7257 at Page 2989 and more particularly described as follows:

30 A IN SW 1/4 SEC 33 6 1E & NW 1/4 SEC 4 5 1E & PT LOT 4 FIRST SLIGO SUBN & 6 FT OFF N/LY SIDE CAPERS ST LESS 70 FT R O W TO CITY FOR ST & LESS 237.28 FT X 320 FT X 102.70 FT TRI IN NW COR LESS 9.34 AC TO JSSD LESS TO MS EMP SEC COMM

WHEREAS, the real property is designated as Parcel Number 112-1 in the Hinds County Landroll; and

WHEREAS, Jackson Resource Center submitted an application to the City of Jackson's Surplus Property Committee requesting that Parcel Number 112-1 be declared surplus and conveyed to Jackson Resource Center for the development of a transitional housing center; and

WHEREAS, Jackson Resource Center is a bona fide not-for profit civic corporation organized and existing under the laws of the State of Mississippi and granted tax-exempt status by the Internal Revenue Service; and

WHEREAS, on December 8, 2022, the City of Jackson's Surplus Property Committee found that (1) Jackson Resource Center's proposed use of the property as a transitional housing center would benefit the civic, social, educational, cultural, moral, economic or industrial welfare of the community in which the property is located; and (2) no City department had expressed a municipal need for the property; and

WHEREAS, based on the above-mentioned findings, the Surplus Property Committee voted to recommend to the governing authorities that Parcel Number 112-1 be declared surplus property and donated as set forth in Mississippi Code Section 21-17-1(3) to Jackson Research Center for use as a transitional housing center; and

WHEREAS, the Surplus Property Committee further recommends that the deed of conveyance contain a clause of reverter providing that Jackson Resource Center may hold title to Parcel Number 112-1 only so long as the property is continued to be used as a transitional housing center and that title shall revert to the City in the event of the cessation of such use as a transitional housing center for a period of two (2) years.

IT IS, THEREFORE, ORDERED that Parcel Number 112-1 located at 300 Capers Street is no longer needed for governmental or related purposes of the City and is declared to be surplus property.

IT IS FURTHER ORDERED that the Mayor is authorized to execute a deed of conveyance and any other documents necessary to donate Parcel Number 112-1 to Jackson Resource Center.

IT IS FURTHER ORDERED that consistent with the provisions of Mississippi Code Section 21-17-1(3), the instrument conveying the property to Jackson Resource Center shall contain a clause of reverter providing that Jackson Resource Center may hold title to Parcel Number 112-1 only so long as the property is used as a transitional housing center and that title shall revert to the City in the event of the cessation of such use as a transitional housing center for a period of two (2) years.

IT IS FURTHER ORDERED that consistent with the provisions of Mississippi Code Section 21-17-1(3), the instrument conveying the property to Jackson Resource Center shall reserve all mineral rights, together with the right of ingress and egress to remove same.

IT IS FURTHER ORDERED that this conveyance is subject to any and all easements, rights-of-way, restrictive covenants or building restrictions of record concerning the property.

Item#: _____

Date:

By: (Miller, Lumumba)

CITY COUNCIL AGENDA ITEM 10 POINT DATA SHEET DATE: 05-09-2023

P O I N T S		C O M M E N T S	
1.	Brief Description	ORDER DECLARING PARCEL NUMBER 112-1 SURPLUS PROPERTY AND AUTHORIZING THE MAYOR TO EXECUTE THE DEED OF CONVEYANCE AND OTHER DOCUMENTS NECESSARY TO DONATE SAID PROPERTY TO JACKSON RESOURCE CENTER FOR THE DEVELOPMENT OF A TRANSITIONAL HOUSING CENTER	
2.	Purpose	Dispose surplus property by the donation method for economic development	
3.	Who will be affected	Neighborhood residents	
4.	Benefits	The City will not have the expense of maintaining the property	
5.	Schedule (beginning date)	N/A	
6.	Location: <ul style="list-style-type: none"> ▪ WARD ▪ CITYWIDE (yes or no) (area) ▪ Project limits if applicable 	Ward 5 No N/A	
7.	Action implemented by: <ul style="list-style-type: none"> ▪ City Department ▪ Consultant 	Department of Planning & Development	
8.	COST	N/A	
9.	Source of Funding <ul style="list-style-type: none"> ▪ General Fund <input type="checkbox"/> ▪ Grant <input type="checkbox"/> ▪ Bond <input type="checkbox"/> ▪ Other <input type="checkbox"/> 	N/A	
10.	EBO participation See attached sheets from Vendors	ABE _____% WAIVER yes ___ no ___ N/A ___X___ AABE _____% WAIVER yes ___ no ___ N/A ___X___ WBE _____% WAIVER yes ___ no ___ N/A ___X___ HBE _____% WAIVER yes ___ no ___ N/A ___X___ NABE _____% WAIVER yes ___ no ___ N/A ___X___	

Department of Planning and Development



200 South President Street
Post Office Box 17
Jackson, Mississippi 39205-0017

MEMORANDUM

To: Chokwe Antar Lumumba, Mayor

From: Latonya Miller, Deputy Director

Date: May 9, 2023

Subject: Agenda Item – Disposition of Surplus property via the donation method (parcel 112-1)

The Surplus Property Committee has considered this property, and after having made it known that the property was available for use, found that no City department expressed an interest in utilizing the property for any municipal purpose.

The attached order authorizes the declaration of parcel 112-1 as surplus property and the subsequent disposal, via the donation method, to Jackson Resource Center.

Office of the City Attorney

455 East Capitol Street
Post Office Box 2779
Jackson, Mississippi 39207-2779
Telephone: (601) 960-1799
Facsimile: (601) 960-1756

OFFICE OF THE CITY ATTORNEY
RM
5/1/23

OFFICE OF THE CITY ATTORNEY

This ORDER DECLARING PARCEL NO. 112-1 SURPLUS PROPERTY AND AUTHORIZING THE MAYOR TO EXECUTE THE DEED OF CONVEYANCE AND OTHER DOCUMENTS NECESSARY TO DONATE SAID PROPERTY TO JACKSON RESOURCE CENTER FOR THE DEVELOPMENT OF A TRANSITIONAL HOUSING CENTER is legally sufficient for placement in NOVUS Agenda.

Catoria Martin, *City Attorney*

Kristie Metcalfe, *Deputy City Attorney*

5/3/23

Date

31

OFFICE OF THE CITY ATTORNEY
5/16/23
JUNE

ORDER AMENDING THE FISCAL YEAR 2022-2023 BUDGET OF THE CITY OF JACKSON DEPARTMENT OF INFORMATION TECHNOLOGY

WHEREAS, the Department of Information Technology needs to amend its 2022-2023 budget to provide essential funds for processing of payment to Tyler Technologies; and

WHEREAS, the Department of Information Technology recommends to the governing authorities for the City of Jackson to amend its 2022-2023 budget in the amount of \$200,112.83 to pay for the License & Services Agreement for Enterprise ERP (Munis) Software and Services; and

WHEREAS, if it affirmatively appears at any time during the current fiscal year that there is in any fund or account any sum remaining unexpended and not needed or expected to be needed for the purpose or purposes for which appropriated in said budget, then the governing authorities may, in their discretion, transfer such sum or any part thereof to any other fund or funds or account or accounts where needed, by order to such effect entered upon their minutes. This shall not, however, authorize the expenditure of any funds for any purpose other than that for which the levy producing such funds was made. Miss. Code. Ann. § 21-35-25 (West); and

WHEREAS, the proposed changes in Fund 4 are necessary to move funds intended for tire tubes battery, uniforms, work clothing, printing supplies, computer software, computer supplies, non-capitalized equipment, data processing equipment, fiber, other building supplies, building material, structural steel, other repair and maintenance, books and periodicals, postage, dues memberships and fees, telephone, cellular phones, building maintenance, structure maintenance, machine equipment maintenance, travel expense, and air travel for the payment of Munis to Tyler Technologies; and

WHEREAS, the Department of Information Technology recommends that the governing authorities amend the following accounts, as follows:

To/From	Fund/Account Number	Amount
From:	004-904.00-6216 (Tire Tubes & Battery)	\$ 300.00
	004.904.00-6217 (Uniforms & Work Clothing)	\$3,000.00
	004.904.00-6219 (Printing Supplies)	\$1,873.72
	004.904.00-6231 (Computer Software)	\$36,759.52
	004.904.00-6234 (Computer Supplies)	\$12,113.24
	004.904.00-6240 (Non-Capitalized Equip.)	\$17,003.00
	004.904.00-6242 (Data Processing Equip.)	\$75,393.59
	004.904.00-6243 (Fiber)	\$12,000
	004.904.00-6299 (Other Operating Supplies)	\$9,072.00
	004.904.00-6311 (Building Material)	\$335.26

004.904.00-6313 (Structural Steel)	\$117.00
004.904.00-6318 (Books & Periodical)	\$72.00
004.904.00-6421 (Postage)	\$1,000.00
004.904.00-6443 (Dues Mem. Regis Fees Tuition)	\$2,761.00
004.904.00-6461 (Buildings Maintenance)	\$1,312.50
004.904.00-6462 (Structure Maintenance)	\$12,000
004.904.00-6473 (Travel Expense)	\$10,000.00
004.904.00-6474 (Air Travel)	\$5,000.00
Total Amount:	\$200,112.83

To: 004-904.00-6419 (Other Professional Services) \$ 200,112.83

WHEREAS, this intradepartmental transfer of \$200,112.83 is in statutory compliance with Section 21-35-25 of the Mississippi Code Annotated, as amended, and this transfer does not exceed ten percent (10%) of the total budget amount appropriated to the Department of Information Technology in the Fiscal Year 2022-2023 Budget.

NOW, IT IS THEREFORE ORDERED, that the Department of Information Technology Fiscal Year 2022-2023 budget be revised as set forth above.

Item No. _____

Agenda Date _____

By: (Reid, Lumumba)

POINTS		COMMENTS
1.	Brief Description/Purpose	ORDER AMENDING THE DEPARTMENT OF INFORMATION TECHNOLOGY 2023 FISCAL YEAR BUDGET
2.	PURPOSE	License & Services Agreement for Enterprise ERP (Munis) Software and Services dated December 10, 2018 (“ERP LSA”), as amended on November 15, 2019, to add Public Safety Software and Services (“Public Safety Addendum”). License and Services Agreement for Municipal Justice (Incode Court) Software and Services dated May 23, 2012 (“Municipal Justice LSA”)
3.	Who will be affected	City of Jackson
4.	Benefits	
5.	Schedule (beginning date)	Upon Council approval
6.	Location: <ul style="list-style-type: none"> ▪ WARD ▪ CITYWIDE (yes or no) (area) ▪ Project limits if applicable 	City Wide
7.	Action implemented by: <ul style="list-style-type: none"> ▪ City Department <input checked="" type="checkbox"/> ▪ Consultant <input type="checkbox"/> 	Information Technology
8.	COST	\$200,112.83
9.	Source of Funding <ul style="list-style-type: none"> ▪ General Fund <input type="checkbox"/> ▪ Grant <input type="checkbox"/> ▪ Bond <input type="checkbox"/> ▪ Other <input checked="" type="checkbox"/> 	Technology Fund 004.904.00-6419 Other Professional Services
10.	EBO participation	ABE _____ % WAIVER yes ___ no ___ N/A _____ AABE _____ % WAIVER yes ___ no ___ N/A _____

		WBE _____ %	WAIVER yes ___ no ___	N/A _____
		HBE _____ %	WAIVER yes ___ no ___	N/A _____
		NABE _____ %	WAIVER yes ___ no ___	N/A _____

Office of the City Attorney

455 East Capitol Street
Post Office Box 2779
Jackson, Mississippi 39207-2779
Telephone: (601) 960-1799
Facsimile: (601) 960-1756

OFFICE OF THE CITY ATTORNEY
5/12/23

OFFICE OF THE CITY ATTORNEY

This **ORDER AMENDING THE FISCAL YEAR 2022-2023 BUDGET OF THE CITY OF JACKSON DEPARTMENT OF INFORMATION TECHNOLOGY** is legally sufficient for placement in NOVUS Agenda.

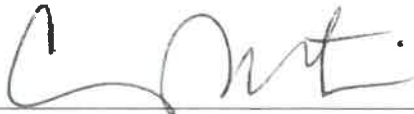

Catoria Martin, *City Attorney*

Sondra Moncure, *Deputy City Attorney* SM

5/14/23
Date

32

OFFICE OF THE CITY ATTORNEY
5/23/23

ORDER AUTHORIZING THE MAYOR TO EXECUTE A FORTY-EIGHT (48) MONTH RENTAL AGREEMENT WITH ADVANTAGE BUSINESS SYSTEMS FOR A KONICA MINOLTA BIZHUB C750i DIGITAL BLACK/WHITE AND COLOR SYSTEM AND THE KONICA MINOLTA BIZHUB 4750i DIGITAL (BLACK/WHITE) TO BE USED BY THE DEPARTMENT OF PUBLIC WORKS.

WHEREAS, the Public Works Department desires to enter into a 48-month rental agreement for a black/white and a multifunction color copier to be used by the Divisions of Administration and Solid Waste; and

WHEREAS, Advantage Business Systems, Inc. provides a Konica Minolta Bizhub C750i b/w and color copier and a Konica Minolta Bizhub 4750i black and white copier with auxiliary equipment through State of Mississippi Contract number 8200067921 at a cost of \$325.00 and \$65.00 monthly totaling \$390.00 a month for forty-eight (48) months; and

WHEREAS, the principal place of business for Advantage Business Systems, Inc., is 5442 Executive Place, Jackson, MS 39206; and

1. **KONICA MINOLTA BIZHUB C750i** to replace **XEROX C8070H** for Public Works Solid Waste – At a monthly rental cost of \$325.00 for forty-eight months and a maintenance charge of \$.0073 for all b/w copies and all color copies billed \$.059 to be invoiced with monthly charge.
2. **KONICA MINOLTA BIZHUB 4750i** to replace **CANON RUNNER ADVANCE 400IF** for Public Works Administration – At a monthly rental cost of \$65.00 for forty-eight months and a maintenance charge of \$.015 for all b/w copies to be invoiced with monthly charge.

WHEREAS, it is the recommendation of the Public Works Department that this lease agreement be approved.

IT IS, THEREFORE, ORDERED that the Mayor is authorized to execute the necessary documents with Advantage Business System providing for the 48-month rental of a Konica Minolta Bizhub C750i b/w and color copier with auxiliary equipment at a cost of \$325.00 per month plus a copy charge of \$.0073 for all (Black and White), \$.059 (Color Impressions) and a Konica Minolta Bizhub 4750i b/w copier with auxiliary equipment at a cost of \$65.00 per month, plus a copy charge of \$0.15 (Black and White) per copy to include toners, parts, drums, except paper or staples, labor and service calls.

IT IS THEREFORE ORDERED that payment for the rental of equipment and the copy charges be made from budgeted funds of the Department of Public Works.

ITEM#: 32
DATE May 23, 2023
BY: LEE LUMUMBA

CITY COUNCIL AGENDA ITEM 10 POINT DATA SHEET

DATE 05/09/2023

P O I N T S		C O M M E N T S																														
1.	Brief Description/Purpose	ORDER AUTHORIZING THE MAYOR TO EXECUTE A FORTY-EIGHT (48) MONTH RENTAL AGREEMENT WITH ADVANTAGE BUSINESS SYSTEMS FOR A KONICA MINOLTA BIZHUB C750i DIGITAL BLACK/WHITE AND COLOR SYSTEM AND THE KONICA MINOLTA BIZHUB 4750i DIGITAL (BLACK/WHITE) TO BE USED BY THE DEPARTMENT OF PUBLIC WORKS.																														
2.	Mayoral Priority Addressed 1. Public Safety 2. Economic Development 3. Housing 4. Infrastructure 5. Quality of Life	PUBLIC SAFETY																														
3.	Public Policy Initiative 1. Youth & Education 2. Crime Prevention 3. Changes in City Government 4. Neighborhood Enhancement 5. Economic Development 6. Infrastructure and Transportation 7. Quality of Life	QUALITY OF LIFE																														
4.	Who/What will be affected & Benefits	CUSTOMERS OF CITY SERVICES																														
5.	Schedule 1. Contract 2. Project (Beginning date) (Completion date)	48 MONTH RENTAL AGREEMENT																														
6.	Location: ▪ WARD ▪ CITYWIDE (yes or no) (area) ▪ Project limits if applicable	ALL ADMINISTRATION AND SOLID WASTE DIVISION OF PUBLIC WORKS DEPARTMENT																														
7.	Action initiated by: ▪ Mayor's Office <input type="checkbox"/> ▪ City Department <input type="checkbox"/> ▪ Consultant <input type="checkbox"/>	DEPARTMENT OF PUBLIC WORKS, ADMINISTRATION AND SOLID WASTE																														
8.	COST	KONICA MINOLTA BIZHUD C750i - \$325.00 MONTHLY KONICA MINOLTA BIZHUD 4750i - \$65.00 MONTHLY TOTAL - \$390.00 RENTAL AND MAINTENANCE																														
9.	Source of Funding ▪ General Fund <input type="checkbox"/> ▪ Enterprise <input checked="" type="checkbox"/> ▪ Grant <input type="checkbox"/> ▪ Bond <input type="checkbox"/> ▪ Other <input type="checkbox"/>	ENTERPRISE FUND:00146110.6514 RENTAL OF EQUIPMENT																														
10.	EBO participation	<table border="0"> <tr> <td>ABE</td><td>_____ %</td> <td>WAIVER</td><td>Yes _____</td> <td>No _____</td> <td>N/A _____</td> </tr> <tr> <td>AABE</td><td>_____ %</td> <td>WAIVER</td><td>Yes _____</td> <td>No _____</td> <td>N/A _____</td> </tr> <tr> <td>WBE</td><td>_____ %</td> <td>WAIVER</td><td>Yes _____</td> <td>No _____</td> <td>N/A _____</td> </tr> <tr> <td>HBE</td><td>_____ %</td> <td>WAIVER</td><td>Yes _____</td> <td>No _____</td> <td>N/A _____</td> </tr> <tr> <td>NABE</td><td>_____ %</td> <td>WAIVER</td><td>Yes _____</td> <td>No _____</td> <td>N/A _____</td> </tr> </table>	ABE	_____ %	WAIVER	Yes _____	No _____	N/A _____	AABE	_____ %	WAIVER	Yes _____	No _____	N/A _____	WBE	_____ %	WAIVER	Yes _____	No _____	N/A _____	HBE	_____ %	WAIVER	Yes _____	No _____	N/A _____	NABE	_____ %	WAIVER	Yes _____	No _____	N/A _____
ABE	_____ %	WAIVER	Yes _____	No _____	N/A _____																											
AABE	_____ %	WAIVER	Yes _____	No _____	N/A _____																											
WBE	_____ %	WAIVER	Yes _____	No _____	N/A _____																											
HBE	_____ %	WAIVER	Yes _____	No _____	N/A _____																											
NABE	_____ %	WAIVER	Yes _____	No _____	N/A _____																											



MEMORANDUM
PUBLIC WORKS DEPARTMENT

Divisions of Administration and Solid Waste

TO: Chokwe Antar Lumumba, Mayor

FROM: Robert Lee, Temporary Public Works Director

DATE: May 9, 2023

RE: 48 Month Rental Agreement with Advantage Business Systems
State of Mississippi Contract # 8200067921

The rental agreement for the copiers with Advantage Business Systems (ABS), located at 5442 Executive Place, Jackson, MS 39206, has proposed a rental and maintenance cost of \$390.00 for two (2) copiers with a 48-month rental agreement to be used at Public Works Administration and Solid Waste. Through state contract # 8200067921, ABS will provide the following:

1. **KONICA MINOLTA BIZHUB C750i** to replace **XEROX C8070H** for **Solid Waste** – At a monthly rental and maintenance fee of \$325.00, includes maintenance and all supplies except paper and staples, 240 pages per minutes b/w copies, monthly duty cycle of 220,000 copies and billed monthly at \$.0073 for all b/w copies and all color copies billed at \$.059.
2. **KONICA MINOLTA BIZHUB 4750i** to replace **CANNON RUNNER ADVANCE** for **Administration** - At a monthly rental and maintenance fee of \$65.00, includes maintenance and all supplies except paper and staples, 50 pages per minute b/w copies, maximum monthly volume of 120,000 copies and billed monthly at \$.015 for all black/white copies.

The previous copiers' lease agreements for Administration and Solid Waste have expired. It is very important that these copiers be replaced as soon as possible in both divisions to process daily assigned routine work.

If you have any questions, please contact me at 601.960.2091

Proposal for: City of Jackson Dept of Public Works

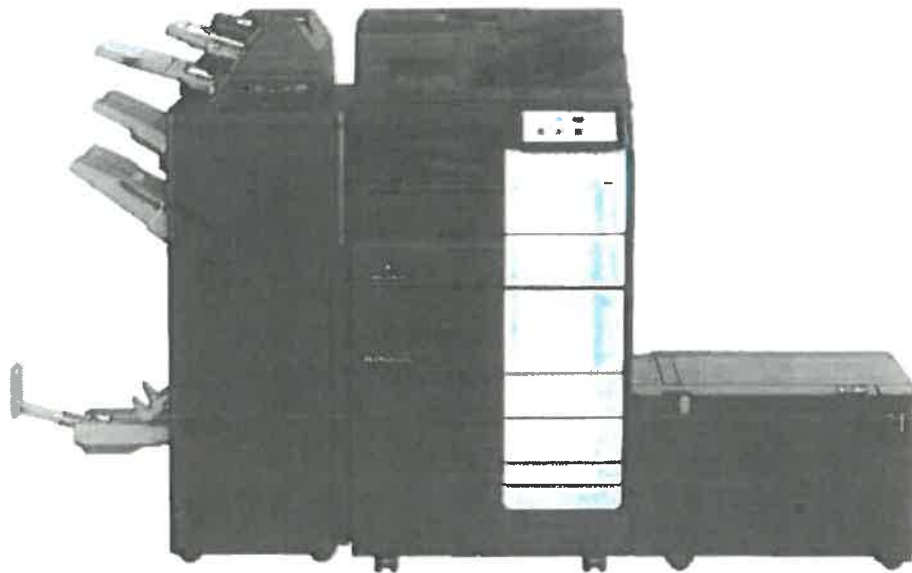

Stock picture (Not actual proposed model)

Advantage Business Systems

**5442 Executive Place
Jackson, MS 39206**

**Donna May (601)362-9192
Cell (601)317-4298**



May 4, 2023

**City of Jackson Dept. of Public Works
200 S President St.
Jackson, MS 39201**

Dear Pat,

Enclosed please find the information on the Konica Minolta Bizhub C750i color copier. I have put into the proposal pricing from Konica Minolta's MS State Contract #8200067921. I hope that we can meet your needs with this pricing.

We look forward to offering you the finest service available. We believe Konica Minolta quality products, blended with our excellent service, are the foundation for a successful partnership.

Thanks again for the opportunity,

Sincerely,

A handwritten signature in cursive script that reads "Donna May". The signature is written in black ink and is positioned to the right of the word "Sincerely,".

**Donna May
Senior Account Executive
Advantage Business Systems**

Konica Minolta Overview

Konica Minolta Business Solutions U.S.A., Inc. (KMBS) is a wholly owned subsidiary of Konica Minolta Holdings, Inc., formed through the merger of Konica, Inc. and Minolta Co., Ltd. With more than 200 years of combined experience, Konica Minolta is building on a long and rich history of developing innovative imaging technologies and bringing new products to market. It is a company that continues to create fresh new impressions in the field of imaging by mobilizing its core competencies in optics, printing and copying, scanning and software to create these products and services.

Headquartered in Ramsey, New Jersey, KMBS provides its customers with complete solutions to efficiently create, reproduce, share and manage document-based information. The company provides the essentials of imaging to companies and organizations ranging from small office/home office to workgroups and departments and to large production operations. Its technologically advanced line of products and services include:

- A complete line of high-speed, high-volume document systems, up to 170 ppm and 1.25 million impressions per month.
- A full line of superior quality color imaging systems for corporate, graphics arts and production environments.
- A wide range of multifunctional workgroup and departmental document systems and facsimile machines with advanced functionality such as network scanning and Internet faxing.
- Software solutions designed to bridge the gap between computers and document systems, offering capabilities from easy scan-to-file to automated document manipulation to total workflow process solutions.
- Desktop monochrome and color laser printing systems.
- Professional services for infrastructure management and document process streamlining.
- Advanced scanning and micrographics systems for document imaging.
- World-class sales, service and support through an extensive network of direct sales offices, authorized dealers, resellers and distributors in the United States, Canada, Mexico, Central America and South America.

Advantage Business Systems Overview

Advantage Business Systems was founded in 1976. Since its inception, Advantage Business Systems has grown rapidly to become one of the premier office equipment suppliers in Central Mississippi. The fast growth is attributed to all of our people being dedicated to providing the finest customer service and representing the innovative digital technologies that Minolta offers.

Our dedication to service is exemplified by our multiple Pro-Tech service awards we have earned and the loyalty of thousands of customers in the metro area.

The service we provide is backed by our Performance Uptime Guarantee, which insures that your equipment is as productive as possible.

We are excited to have the opportunity to serve your company's document management needs now and into the future.

PROPOSED CONFIGURATION

The following Konica Minolta Bizhub C750i Digital Color System provides these features:

- 75 ppm black/white and color
- **Dual head scanning @240 pages per minute (handles 300 pages) black/white and color**
- First copy output in 3.6 seconds or less
- Warm Up time of less than 22 seconds
- 600 x 600dpi scanning or enhanced @ 600 X 1800dpi
- 2 X 500 sheet drawers, 1 X 1000 sheet drawer, 1 X 1500 sheet drawer and 150 sheet intelligent bypass
- Polymerized toner system
- 250 GB Hard Drive
- Staple Finisher with 2/3 hole punch
- Super 3G Fax
- Standard and custom paper size support up to 12" x 18"
- 10.1" Color Display
- Monthly duty Cycle of 220,000 copies
- Network Printing and Scanning
- Box Functionality (Stores up to 10,000 pages)
- User Authentication, Account Track, IOS 15408 Certification
- Scan to me and Scan to home
- Print to USB and from USB
- Print from iPad, iPhone or Android devices
- Banner Printing



**48 Month Rental
\$325.00**

PROPOSED CONFIGURATION

The following Konica Minolta Bizhub 4750I Digital B/W System provides these features:

- Up to 50 pages per minute
- Maximum monthly volume: 120,000
- USB printing
- Print/copy/scan/fax(option)
- Color scanning
- Super 3G Fax
- 80 sheet duplexing auto document feeder
- 10.1" Touch Screen
- 2 X 500 sheet drawer and 100 sheet bypass
- Cabinet

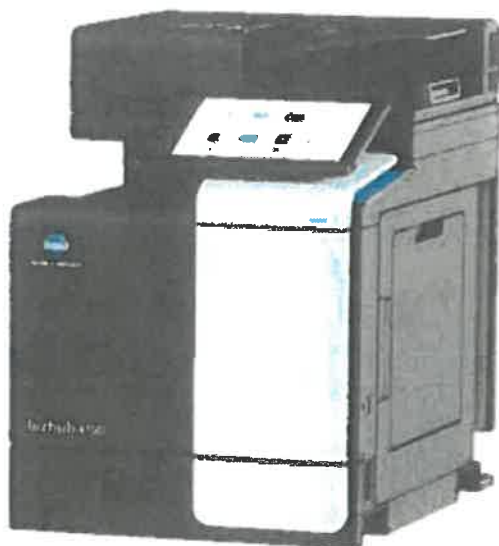

48 Month Rental: \$65.00

Maintenance Program:

- ❖ All toner cartridges
- ❖ All other consumables except paper
- ❖ All parts, drums, labor and service calls
- ❖ Preventative maintenance procedures
- ❖ Unlimited on-site customer training
- ❖ Can be billed monthly, quarterly or annually

Bizhub C7501

Billed monthly @ \$.0073 for all b/w copies and all color copies billed @ \$.059.
(based on single sided, letter sized image)

Bizhub 47501

Billed monthly @ \$.015 for all b/w copies
(based on single sided, letter sized image)

Office of the City Attorney

455 East Capitol Street
Post Office Box 2779
Jackson, Mississippi 39207-2779
Telephone: (601) 960-1799
Facsimile: (601) 960-1756

OFFICE OF THE CITY ATTORNEY
MAY 17 2023

OFFICE OF THE CITY ATTORNEY

This **ORDER AUTHORIZING THE MAYOR TO EXECUTE A FORTY-EIGHT (48) MONTH RENTAL AGREEMENT WITH ADVANTAGE BUSINESS SYSTEMS FOR A KONICA MINOLTA BIZHUB C750i DIGITAL BLACK/WHITE AND COLOR SYSTEM AND THE KONICA MINOLTA BIZHUB 4750i DIGITAL (BLACK/WHITE) TO BE USED BY THE DEPARTMENT OF PUBLIC WORKS.** is legally sufficient for placement in NOVUS Agenda.

Terry Williamson, Legal Counsel

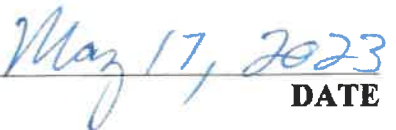
DATE

33

ORDER RATIFYING CONTRACTS RELATED TO THE EMERGENCY REPAIRS TO THALIA MARA HALL AND THE ARTS CENTER OF MISSISSIPPI IN PREPARATION FOR THE U.S.A. INTERNATIONAL BALLET COMPETITION

OFFICE OF THE CITY ATTORNEY
5/17/2023

WHEREAS, the City of Jackson Department of Public Works and Department of Human and Cultural Services are currently in the process of preparing Thalia Mara Hall and the Arts Center of Mississippi for the USA International Ballet Competition (“USA IBC”); and

WHEREAS, the USA IBC is a two-week Olympic-style competition for top young dancers from all over the world, which occurs every four (4) years in the City of Jackson and is scheduled to take place June 10, 2023 through June 24, 2023; and

WHEREAS, the 2018 USA IBC was attended by more than 44,000 people generating a combined economic impact of \$12.5 million for the City of Jackson and the State of Mississippi; and

WHEREAS, the USA IBC is scheduled to begin June 10, 2023 and there are necessary repairs which must take place at both Thalia Mara and the Arts Center of Mississippi prior to June 10, 2023; and

WHEREAS, the City of Jackson previously contracted with Cooke Douglass Farr Lemons (“CDFL”) to produce a scope of work for Thalia Mara Hall; and

WHEREAS, the City has contracted Canizaro Cawthon Davis, A Professional Association to produce a scope of work for the Arts Center of Mississippi, which scope is to include an update to the existing public restrooms to bring them into compliance with the ADA due to performance issues with Construction Specialists, LLC, which recently caused the City to terminate that construction agreement; and

WHEREAS, the City has authorized a contract with Benchmark Construction Corporation, whose principal office address is 1867 Crane Ridge Drive #200A, Jackson, MS 39216, to provide general contractor services to assist the City of Jackson with completing the proposed scope of work for Thalia Mara Hall by June 1, 2023; and

WHEREAS, pursuant to Miss. Code Ann. § 31-7-13(k), due to the threat of economic loss based on the restricted time period, limitations of available equipment, materials and delivery schedules, and to protect and preserve the facilities, the City of Jackson invoked the emergency procurement procedure for the intended repairs to Thalia Mara and the Arts Center, a copy of which is attached hereto; and

WHEREAS, pursuant to the emergency procurement process, the following proposals have been accepted for work or materials, which constitute a contract for the work, a copy of said contracts being attached to this Order and made a part of the minutes of this meeting:

Item # 33
Date: May 23, 2023
By: R. Lee, Lumumba

Vendor	Services/Materials	Amount
ADCO Electrical	Lobby and Director's Office Lights	\$1,730.00
Adams Evans Waterproofing Co.	Power wash, coating & sealant	\$4,423.00
Elite Paint	Remove concrete base slabs, statues	\$3,900.00
Guaranteed Roofing	Roof Repair	\$3,214.00
	Total	\$13,267.00

IT IS, THEREFORE, ORDERED that the contracts for work listed in the proposals listed above at the amounts stated are hereby ratify.

**DECLARATION INVOKING THE EMERGENCY
PROCUREMENT PROCEDURE**

I. REQUEST

The City of Jackson Department of Public Works and Department of Human and Cultural Services are currently in the process of preparing Thalia Mara Hall and the Arts Center of Mississippi for the USA International Ballet Competition ("USA IBC"). The USA IBC is a two-week Olympic-style competition for top young dancers from all over the world, which occurs every four (4) years in the City of Jackson and is scheduled to take place June 10, 2023 through June 24, 2023. The 2018 USA IBC was attended by more than 44,000 people generating a combined economic impact of \$12.5 million for the City of Jackson and the State of Mississippi.

The USA IBC is scheduled to begin June 10, 2023 and there are necessary repairs which must take place at both Thalia Mara and the Arts Center of Mississippi prior to June 10, 2023. The City of Jackson previously contracted with Cooke Douglass Farr Lemons ("CDFL") to produce a scope of work for Thalia Mara Hall. The City recently retained Canizaro Cawthon Davis, A Professional Association to produce a scope of work for the Arts Center of Mississippi, which scope is to include an update to the existing public restrooms to bring them into compliance with the ADA due to performance issues with Construction Specialists, LLC, which recently caused the City to terminate that construction agreement.

Today, the City authorized a contract with Benchmark Construction Corporation, whose principal office address is 1867 Crane Ridge Drive #200A, Jackson, MS 39216, to provide general contractor services to assist the City of Jackson with completing the proposed scope of work for Thalia Mara Hall by June 1, 2023.

Without the completion of the repairs, the City will be greatly hampered in its effort to host the USA IBC. Hosting the event without these repairs will reflect badly on the City of Jackson, could damage the City's efforts to host USA IBC in the future, and could result in a significant economic loss to the City.

As a result, I am requesting the procurement of the construction services and materials necessary to make the repairs and renovations to Thalia Mara Hall and the Arts Center of Mississippi identified by the two architectural firms and Benchmark Construction Corporation.

Accordingly, I request that you declare that this situation constitutes an "emergency" as that term is defined in Section 31-7-1 of the Mississippi Code Annotated of 1972, as amended, and authorize contracts for the construction services and materials necessary to make the repairs and renovations to Thalia Mara Hall and the Arts Center of Mississippi identified by the two architectural firms and Benchmark Construction Corporation, pursuant to Section 31-7-13 (j) of the Mississippi Code Annotated of 1972, as amended.

As background information to assist in your determination that an emergency exists, I have attached a memorandum. I have also obtained the review and approval of the Office of the City Attorney, the Chief Financial Officer, and the Chief Administrative Officer as evidenced by the signatures below.



Robert Lee, P.E.
City Engineer and Interim Director

3/9/23

DATE

II. REVIEWED AND APPROVED



Torri Martin
City Attorney

3/9/23

DATE

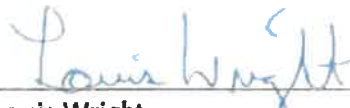

Louis Wright
Chief Administrative Officer

3/9/23

DATE

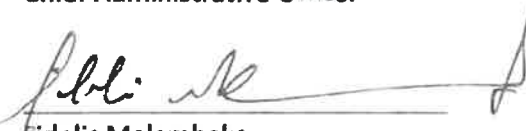

Fidelis Malembeka
Chief Financial Officer

3/9/23

DATE

III. DECLARATION OF EMERGENCY

I hereby determine that present physical condition of the City of Jackson Arts Center constitutes an emergency as that term is defined under Section 31-7-1 of the Mississippi Code Annotated of 1972, as amended, so that the delay incident to giving opportunity for competitive bidding would be detrimental to the interest of the City of Jackson, Mississippi and its citizens, and that contracts for the construction services and materials necessary to make the repairs and renovations identified by the two architectural firms and Benchmark Construction Corporation are authorized pursuant to Section 31-7-13 (k) of the Mississippi Code Annotated of 1972, as amended.

Accordingly, this request is approved, effective February 28, 2023.



CHOKWE A. LUMUMBA
Mayor

3/9/23

DATE

Department of Public Works



200 South President Street
Post Office Box 17
Jackson, Mississippi 39205-0017

Chokwe Antar Lummba
Mayor of the City of Jackson

MEMORANDUM

TO: Robert Lee, City Engineer and Interim Director of the Department of Public Works

FROM: Terry S. Williamson, Legal Counsel *TSW*

RE: Repairs to City Facilities Necessary to Hosting the USA International Ballet Competition

DATE: February 28, 2023

The City of Jackson Department of Public Works and Department of Human and Cultural Services are currently in the process of preparing Thalia Mara Hall and the Arts Center of Mississippi for the USA International Ballet Competition ("USA IBC"). The USA IBC is a two-week Olympic-style competition for top young dancers from all over the world, which occurs every four (4) years in the City of Jackson and is scheduled to take place June 10, 2023 through June 24, 2023. The 2018 USA IBC was attended by more than 44,000 people generating a combined economic impact of \$12.5 million for the City of Jackson and the State of Mississippi.

The USA IBC is scheduled to begin June 10, 2023 and there are necessary repairs which must take place at both Thalia Mara and the Arts Center of Mississippi prior to June 10, 2023. The City of Jackson previously contracted with Cooke Douglass Farr Lemons ("CDFL") to produce a scope of work for Thalia Mara Hall. The City recently retained Canizaro Cawthon Davis, A Professional Association to produce a scope of work for the Arts Center of Mississippi, which scope is to include an update to the existing public restrooms to bring them into compliance with the ADA due to performance issues with Construction Specialists, LLC, which recently caused the City to terminate that construction agreement.

Today, the City authorized a contract with Benchmark Construction Corporation, whose principal office address is 1867 Crane Ridge Drive #200A, Jackson, MS 39216, to provide general contractor services to assist the City of Jackson with completing the proposed scope of work for Thalia Mara Hall by June 1, 2023.

Without the completion of the repairs, the City will be greatly hampered in its effort to host the USA IBC. Hosting the event without these repairs will reflect badly on the City of Jackson, could damage the City's efforts to host USA IBC in the future, and could result in a significant economic loss to the City.

Please let me know if you have any questions.



**BENCHMARK
CONSTRUCTION
CORPORATION**

April 28, 2023

Catoria P. Martin
City Attorney
City of Jackson, MS
Post Office Box 2779
Jackson, MS 39207

Re: Arts Center, Lobby & Director's Lights

Dear Ms. Martin:

Please find attached a proposal from ADCO in the amount of \$1,730.00 I have reviewed the proposal and recommend it be accepted.

Please let me know if you have any questions.

Sincerely,

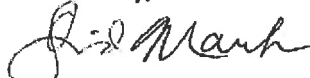
David Marsh,
President

Accepted by: 

City of Jackson, Mississippi

ADCO ELECTRIC INC.
CONTRACTORS ENGINEERS



2236 MADDOX ROAD P.O. BOX 7395
JACKSON, MISSISSIPPI 39282-7395
(601) 922-3575 FAX (601) 922-9705

PROPOSAL

Date: 4/27/23

To: David Marsh

c/o Benchmark Construction Management

Re: MS Arts Center Lobby and Directors Office Lights

David,

We are pleased to provide our price to provide and install the new Lights indicated by the Architect's Drawing for the Arts Center lower Lobby and Directors office This Proposal includes the (7) Flat Panel lights and (3) Exit Lights in the new Lobby Ceiling and the (2) new Flat Panel lights in the Director's Office and one 4' Trac lighting Base trac, all as per the Architects CR#04 Drawing dated 4/21/23.

Our price including Tax for this installed work is: \$ 1,730

Please advise if we are to proceed with this new work and we will order the lights and equipment as needed.

As time is of the essence on this project; this price will be good for 7 calendar days from date of this proposal.

Respectfully submitted,

Andy Hardin, VP

Adco Electric, Inc.



BENCHMARK

May 1, 2023

Catoria P. Martin
City Attorney
City of Jackson, MS
Post Office Box 2779
Jackson, MS 39207

Re: Arts Center – Power wash, coating & sealant

Dear Ms. Martin:

Please find attached a proposal from Adam Evans Waterproofing Co., Inc. in the amount of \$4,423.00. I have reviewed the proposal and recommend it be accepted.

Please let me know if you have any questions.

Sincerely,

David Marsh,
President

Accepted by:

City of Jackson, Mississippi



ADAM EVANS WATERPROOFING CO., INC.

P.O. Box 1325 / Brandon, Mississippi 39043

Telephone (601) 706-0412

Fax (601) 706-0413

April 20, 2023

City of Jackson
c/o Mr. David March
Benchmark Construction
1867 Crane Ridge Dr. Ste 200
Jackson, MS 39201

RE: Arts Center, Jackson, Mississippi
West stair temporary coating

Mr. Marsh,

Attached and in accordance with the sketch by Canizaro Cawthon Davis sent Monday, April 17, 2023, please find two photos indicating the approximate temporary coating areas. Pursuant to your request and our investigation of the referenced project, we propose to furnish all labor, material, equipment and AEW standard insurance to complete the following scope of work:

- 1) Power wash exterior concrete deck, existing coating, masonry rowlock and roof termination flashing.
- 2) Apply three coats of Soprema's Alsan Flashing with fiberglass reinforcement at the prepared area.
- 3) Perform preparation in accordance with manufacturer's instructions and install DowSil's 790 silicone sealant at the west stair bottom to top of wall joint.

Price: \$ 4,423.00

Mr. David Marsh
April 20, 2023
Page2

Note that we make no guaranty that completion of this scope of work will cause the cessation of moisture into the structure. We appreciate the opportunity to offer this quotation. If there are any questions, please call.

Sincerely,



Sean Dunaway

SCW Photo One

Approximate temporary
coating area, north of stair

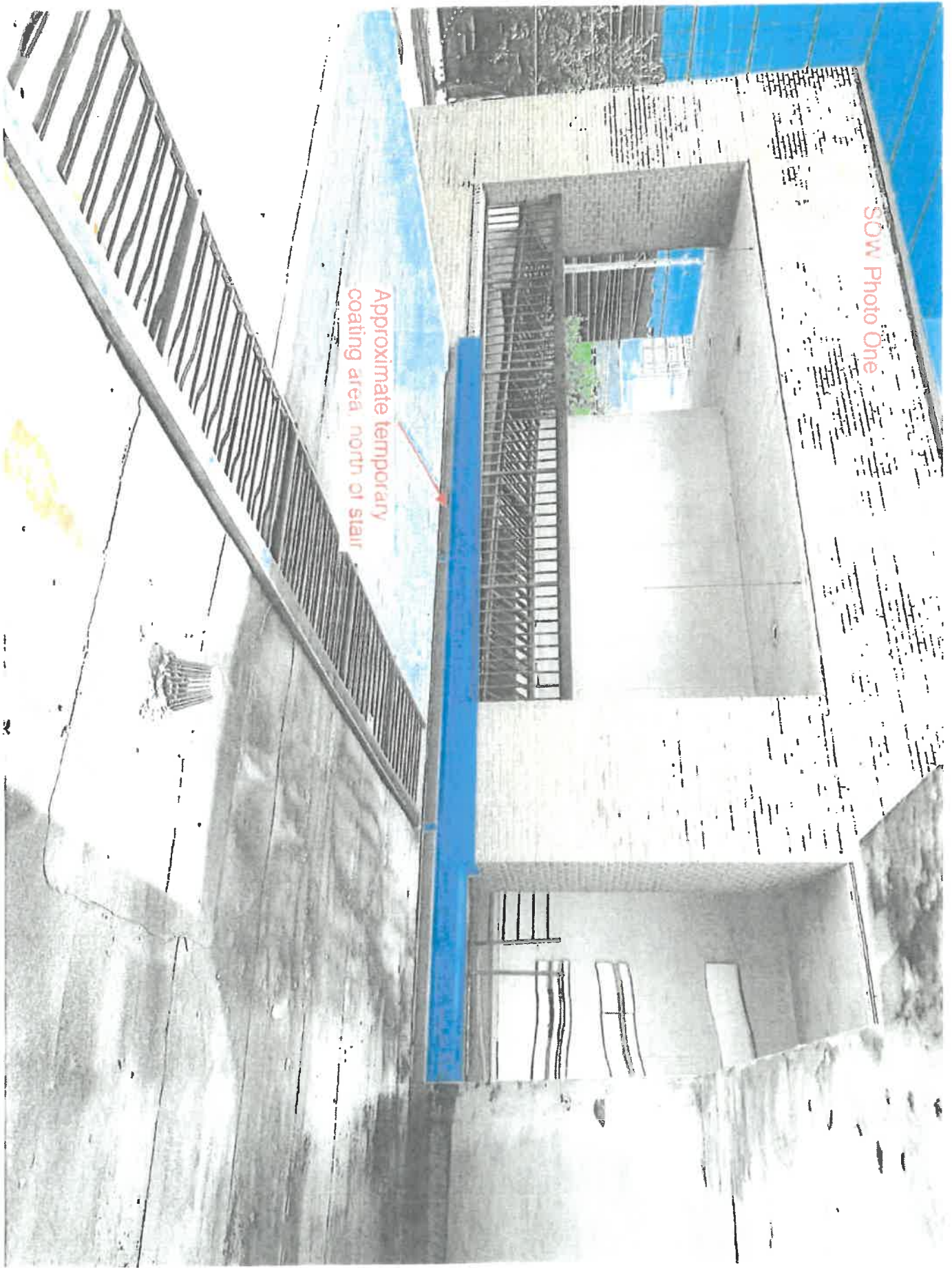



Sealant here

Approximate temporary coating area, south of stair



BENCHMARK

FOR THE
CITY OF JACKSON

May 4, 2023

Catoria P. Martin
City Attorney
City of Jackson, MS
Post Office Box 2779
Jackson, MS 39207

Re: Thalia Mara – Concrete Base Slab

Dear Ms. Martin:

Please find attached a proposal from Elite Paint in the amount of \$3,900.00. I have reviewed the proposal and recommend it be accepted.

Please let me know if you have any questions.

Sincerely,

David Marsh,
President

Accepted by:

City of Jackson, Mississippi



ELITE PAINT LLC
156 Greenfield Ridge Dr.
Brandon, Ms, 39042
josef@elitepaintllc.com
Cell 601-717-2976

TO: BENCHMARK CONSTRUCTION
1867 Crane Ridge Drive Suite 200-A
Jackson, MS 39216

estimate	Date
#042	May/3/23

Project: Thalla Mara Hall
Address: 255 E Pascagoula St.
Jackson, MS 39201

Flags,
Remover 12 in, 2 concrete base slab.

Total \$ 3,900

Respectfully, Jose Fonseca



BENCHMARK
CONSTRUCTION
CORPORATION

May 4, 2023

Catoria P. Martin
City Attorney
City of Jackson, MS
Post Office Box 2779
Jackson, MS 39207

Re: Thalia Mara – Roof Repair

Dear Ms. Martin:

Please find attached a proposal from Guaranteed Roofing in the amount of \$3,214.00. I have reviewed the proposal and recommend it be accepted.

Please let me know if you have any questions.

Sincerely,

David Marsh,
President

Accepted by: 

City of Jackson, Mississippi



PROPOSAL

May 5, 2023

1. Repair three small penetration roughly 1/2" in diameter
2. Repair one lift in roof Cap Sheet
3. Clean Sludge off of roof around two roof drains

This proposal is for above mentioned repair only. There is no guarantee for other leaks reported.

Price for repair \$ 3,214.00

Thank you,

Shelley R. Joiner
Vice President

601-939-2848

renee@guaranteedroofingcompany.com
www.greastroofers.com

P.O. Box 54122
Pearl, MS 39288-4122

Renee Joiner

Guaranteed Roofing Company

5/4/2023 | 4 Photos



Investigate Leak

Investigate Leak

1



Project: Thalia Mara

2



Thalia Mara

3



Thalia Mara

4



Thalia Mara

Thalia Mara

The CITY COUNCIL AGENDA ITEM 10 POINT DATA SHEET

5/17/2023
DATE

POINTS		COMMENTS								
1.	Brief Description/Purpose	ORDER RATIFYING CONTRACTS RELATED TO THE EMERGENCY REPAIRS TO THALIA MARA HALL AND THE ARTS CENTER OF MISSISSIPPI IN PREPARATION FOR THE U.S.A. INTERNATIONAL BALLET COMPETITION								
2.	Public Policy Initiative 1. Youth & Education 2. Crime Prevention 3. Changes in City Government 4. Neighborhood Enhancement 5. Economic Development 6. Infrastructure and Transportation 7. Quality of Life	5. Economic Development 6. Infrastructure & Transportation 7. Quality of Life								
3.	Who will be affected	Department of Public Works								
4.	Benefits	Presents the City in the best possible light for the International Ballet Competition and the numerous out-of-town attendees								
5.	Schedule (beginning date)	Upon Council Approval								
6.	Location: ▪ WARD ▪ CITYWIDE (yes or no) (area) ▪ Project limits if applicable	City Wide								
7.	Action implemented by: ▪ City Department <input checked="" type="checkbox"/> ▪ Consultant <input type="checkbox"/>	Department of Public Works; Department of Human & Cultural Services								
8.	COST	\$13,267.00								
9.	Source of Funding ▪ Enterprise Fund <input type="checkbox"/> ▪ Grant <input type="checkbox"/> ▪ Bond <input checked="" type="checkbox"/> ▪ Other <input type="checkbox"/>	Bond Funds for the Repair of Thalia Mara Hall and the Arts Center of Mississippi								
10.	EBO participation	ABE	_____ %	WAIVER	yes	___	no	___	N/A	<u> x </u>
		AABE	_____ %	WAIVER	yes	___	no	___	N/A	<u> x </u>
		WBE	_____ %	WAIVER	yes	___	no	___	N/A	<u> x </u>
		HBE	_____ %	WAIVER	yes	___	no	___	N/A	<u> x </u>
		NABE	_____ %	WAIVER	yes	___	no	___	N/A	<u> x </u>



DEPARTMENT OF PUBLIC WORKS

MEMORANDUM

To: Mayor Chokwe Antar Lumumba

From: Robert Lee, P.E.
City Engineer & Interim Director

Date: May 17, 2023

Subject: Agenda Item for City Council Meeting

Attached, you will find an agenda item ratifying contracts with vendors to make repairs to Thalia Mara Hall and the Arts Center of Mississippi to prepare those venues for the upcoming USA IBC.

Please let me know if you have any questions.

Office of the City Attorney

OFFICE OF THE CITY ATTORNEY
455 East Capitol Street
Post Office Box 2779
Jackson, Mississippi 39207-2779
Telephone: (601) 960-1799
Facsimile: (601) 960-1756

OFFICE OF THE CITY ATTORNEY

This **ORDER RATIFYING CONTRACTS RELATED TO THE EMERGENCY REPAIRS TO THALIA MARA HALL AND THE ARTS CENTER OF MISSISSIPPI IN PREPARATION FOR THE U.S.A. INTERNATIONAL BALLET COMPETITION** is legally sufficient for placement in NOVUS Agenda.

Terry Williamson, Legal Counsel

5/17/2023
DATE

#34

OFFICE OF THE CITY ATTORNEY
5/23/2023

ORDER RATIFYING A CONTRACT WITH MS TIRE RECYCLING FOR TIRE COLLECTION AND RECYCLING FOR THE SOLID WASTE DIVISION OF THE DEPARTMENT OF PUBLIC WORKS AND AUTHORIZING PAYMENT

WHEREAS, MS Tire Recycling was selected by governing authorities of the City of Jackson and awarded a contract for the collection and disposal of waste tires on January 27, 2017; and

WHEREAS, due to exigent circumstances, illegally dumped waste tires had to be removed from the City right-of-ways and properties within the City limits past the expiration of the contract; and

WHEREAS, MS Tire Recycling agreed to provide the disposal and collection services at the rates provided by the expired contract, which are set forth in the invoices attached to this Order; and

WHEREAS, the Solid Division confirms that the collection and disposal of the tires identified in the attached invoices was done by MS Tire Recycling and that these services benefited the City.

IT IS, THEREFORE, ORDERED that a contract complying with the terms and conditions of the January 27, 2017 Contract except for the term of the contract which shall be for December 15, 2021 through June 15, 2022 is hereby ratified.

IT IS FURTHER ORDERED that payment to MS Tire Recycling in the amounts set forth be made pursuant to the ratified contract, consistent with the attached invoices:

MS Tire Recycling	\$ 1,602.00
MS Tire Recycling	\$ 530.00
MS Tire Recycling	\$ 1,932.00
MS Tire Recycling	\$ 5,214.00
MS Tire Recycling	\$ 590.00
Total	\$ 9,868.00

Mississippi Tire Recycling
 2845 Meter Road
 Jackson, Ms. 39204
 Phone # 601-352-7165

Number 1666
 Date 3/1/2022

Bill To
 City Of Jackson
 Solid Waste Divison
 200 S.President St
 Jackson, Ms.,39205

Ship To

PO Number	Terms	Project
1666	\$200 per ton	waste tires

Date	Description	Hours	Rate	Amount
12/27/2021	waste tires	2.19	\$200.00	\$438.00
12/22/2021	waste tires	3.64	\$200.00	\$728.00
1/10/2022	waste tires	0.84	\$200.00	\$168.00
1/19/2022	waste tires	0.63	\$200.00	\$126.00
2/09/222	waste tires	0.71	\$200.00	\$142.00

Amount Paid \$0.00
 Amount Due \$1,602.00

Discount \$0.00
 Shipping Cost \$0.00
 Sub Total \$1,602.00

Total \$1,602.00

0 - 30 days	31 - 60 days	61 - 90 days	> 90 days	Total
\$1,602.00	\$0.00	\$1,492.00	\$0.00	\$3,094.00

Mississippi Tire Recycling
 2845 Meler Road
 Jackson, Ms. 39204
 Phone # 601-352-7165

Invoice

Number: 1728
 Date: 5/31/2022

Bill To
 City Of Jackson
 Solid Waste Divison
 200 S.President St
 Jackson, Ms, 39205

Ship To

PO Number	Terms	Project
1728	\$200 per ton	waste tires

Date	Description	Hours	Rate	Amount
4/07/22	waste tires	1.23	\$200.00	\$246.00
5/04/22	waste tires	0.52	\$200.00	\$104.00
5/18/22	waste tires	0.90	\$200.00	\$180.00

Amount Paid	\$0.00	Discount	\$0.00
Amount Due	\$530.00	Shipping Cost	\$0.00
		Sub Total	\$530.00
		Total	\$530.00

✓ 0 - 30 days	31 - 60 days	61 - 90 days	> 90 days	Total
\$530.00	\$5,214.00	\$0.00	\$3,094.00	\$8,838.00

Mississippi Tire Recycling
 2845 Meter Road
 Jackson, Ms. 39204
 Phone # 601-352-7165

Invoice

Number 1729

Date 5/31/2022

Bill To

Byram Landfill
 PO Box 17
 Jackson, Ms, 39025

Ship To

PO Number	Terms	Project
1729	\$200 per ton	waste tires

Date	Description	Hours	Rate	Amount
5/17/2022	waste tires	7.66	\$200.00	\$1,532.00
	tractor tires	4.00	\$100.00	\$400.00

Amount Paid	\$0.00	Discount	\$0.00
Amount Due	\$1,932.00	Shipping Cost	\$0.00
		Sub Total	\$1,932.00
		Total	\$1,932.00

✓ 0 - 30 days	31 - 60 days	61 - 90 days	> 90 days	Total
\$1,932.00	\$0.00	\$0.00	\$25,542.00	\$27,474.00

Mississippi Tire Recycling
 2845 Main Road
 Jackson, Ms 39204
 Phone # 601-552-2700

Invoice

Number: 1685

Date: 4/5/2022

Bill To

City Of Jackson
 Solid Waste Divison
 200 S.President St
 Jackson, Ms, 39205

Ship To

Job Number	Terms	Project
1685	\$200 per ton	waste tires

Date	Description	Hours	Rate	Amount
3/28/2022	waste tires	2.75	\$200.00	\$550.00
3/28/2022	waste tires	1.10	\$200.00	\$220.00
3/28/2022	waste tires	2.53	\$200.00	\$506.00
3/29/2022	waste tires	2.68	\$200.00	\$536.00
3/29/2022	waste tires	2.48	\$200.00	\$496.00
3/29/2022	waste tires	2.70	\$200.00	\$540.00
3/30/2022	waste tires	1.93	\$200.00	\$386.00
3/30/2022	waste tires	2.86	\$200.00	\$572.00
3/30/2022	waste tires	3.12	\$200.00	\$624.00
3/29/2022	waste tires	2.73	\$200.00	\$546.00
3/8/2022	waste tires	0.84	\$200.00	\$168.00
3/9/2022	waste tires	0.35	\$200.00	\$70.00

	0 - 30 days	31 - 60 days	61 - 90 days	> 90 days	Total
✓	\$5,214.00	\$1,602.00	\$0.00	\$1,492.00	\$8,308.00

Mississippi Tire Recycling
 2845 Meter Road
 Jackson, Ms. 39204
 Phone # 601-352-7165

Invoice

Number: 1753
 Date: 6/30/2022

Bill To
 City Of Jackson
 Solid Waste Divison
 200 S. President St
 Jackson, Ms, 39205

Ship To

PO Number	Terms	Project
1753	\$200 per ton	waste tires

Date	Description	Hours	Rate	Amount
6/1/2022	Waste tires	1.45	\$200.00	\$290.00
6/8/2022	Waste tires	1.50	\$200.00	\$300.00

Amount Paid	\$0.00	Discount	\$0.00
Amount Due	\$590.00	Shipping Cost	\$0.00
		Sub Total	\$590.00
		Total	✓ \$590.00

0 - 30 days	31 - 60 days	61 - 90 days	> 90 days	Total
\$1,120.00	\$0.00	\$5,214.00	\$3,094.00	\$9,428.00

CITY COUNCIL AGENDA ITEM 10 POINT DATA SHEET
5/17/2023

P O I N T S		C O M M E N T S								
1.	Brief Description/Purpose	ORDER RATIFYING A CONTRACT WITH MS TIRE RECYCLING FOR TIRE COLLECTION AND RECYCLING FOR THE DEPARTMENT OF PUBLIC WORKS								
2.	Public Policy Initiative 1. Youth & Education 2. Crime Prevention 3. Changes in City Government 4. Neighborhood Enhancement 5. Economic Development 6. Infrastructure and Transportation 7. Quality of Life	Quality of Life								
3.	Who will be affected	Department of Public Works								
4.	Benefits									
5.	Schedule (beginning date)	Upon Council Approval								
6.	Location: ▪ WARD ▪ CITYWIDE (yes or no) (area) ▪ Project limits if applicable	City Wide								
7.	Action implemented by: ▪ City Department <input checked="" type="checkbox"/> ▪ Consultant <input type="checkbox"/>	Department of Public Works								
8.	COST	\$9,868.00								
9.	Source of Funding ▪ Enterprise Fund <input checked="" type="checkbox"/> ▪ Grant <input type="checkbox"/> ▪ Bond <input type="checkbox"/> ▪ Other <input type="checkbox"/>	009-455.10.6419								
10.	EBO participation	ABE	_____ %	WAIVER	yes	___	no	___	N/A	___
		AABE	_____ %	WAIVER	yes	___	no	___	N/A	___
		WBE	_____ %	WAIVER	yes	___	no	___	N/A	___
		HBE	_____ %	WAIVER	yes	___	no	___	N/A	___
		NABE	_____ %	WAIVER	yes	___	no	___	N/A	___



DEPARTMENT OF PUBLIC WORKS

MEMORANDUM

To: Mayor Chokwe Antar Lumumba

From: Robert Lee, P.E.
City Engineer & Interim Director

Date: May 17, 2023

Subject: Agenda Item for City Council Meeting

Attached, you will find an agenda item authorizing payment to MS Tire Recycling for payment for invoices for collection and disposal of waste tires. It is the recommendation of this office that this item be approved. If you have any questions, please call me.

Office of the City Attorney

OFFICE OF THE CITY ATTORNEY
455 East Capitol Street
Post Office Box 2729
Jackson, Mississippi 39207-2729
Telephone: (601) 960-1799
Facsimile: (601) 960-1756
5/17/23

OFFICE OF THE CITY ATTORNEY

This **ORDER RATIFYING A CONTRACT WITH MS TIRE RECYCLING FOR TIRE COLLECTION AND RECYCLING FOR THE SOLID WASTE DIVISION OF THE DEPARTMENT OF PUBLIC WORKS AND AUTHORIZING PAYMENT** is legally sufficient for placement in NOVUS Agenda.

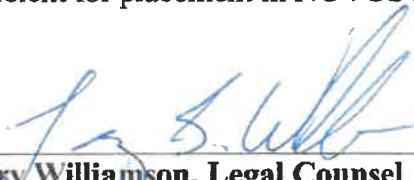

Terry Williamson, Legal Counsel

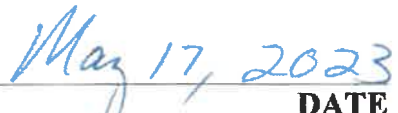

DATE

#35

ORDER AUTHORIZING THE MAYOR TO EXECUTE AN AGREEMENT WITH THE PUBLIC RIGHTS PROJECT TO REPRESENT THE CITY IN CHALLENGING THE LEGALITY OF ACTIONS TAKEN DURING THE 2023 MISSISSIPPI LEGISLATIVE SESSION (ALL WARDS)

OFFICE OF THE CITY ATTORNEY
MAYOR
MAY 23, 2023

WHEREAS, the City of Jackson seeks legal representation from experienced attorneys with expertise and training to sufficiently protect the interest of the City of Jackson in any matters related to actions taken during the 2023 Mississippi Legislative Session; and

WHEREAS, Public Rights Project (“Firm”) and its attorneys have the expertise and training to protect the best interest of the City of Jackson in lawsuits or any other matters concerning actions taken during the 2023 Mississippi Legislative Session; and

WHEREAS, it would be in the best interests of the City to enter into a legal services agreement with the Public Rights Project to perform all duties associated with representation of the City in these matters on a pro bono basis; and

WHEREAS, the Public Rights Project agrees (1) to bear all costs, unless otherwise specified in the agreement or a subsequent mutually agreed upon written agreement, (2) to provide its services and litigation expenses associated with this lawsuit free of charge, except the City will be solely responsible for any fees, costs, or sanctions imposed by a court because of any factual misrepresentations that the City has made to the Firm or for sanctions imposed by the court because of the City’s failure to comply with a court order, provided that the City is given reasonable notice of the court’s order, (3) to be responsible for all costs otherwise associated with the case that it accrues, including travel, filing fees, deposition costs, and other out-of-pocket costs, however, the City will bear responsibility for any incidental costs of participation in the litigation that the City accrues on its own, such as printing, shipping, legal research, and telecommunications costs and in no event shall the Firm be responsible to reimburse the City for any time or expense the City incurs on its own as a result of being involved in this matter; and

WHEREAS, the agreement shall commence on May 23, 2023 and shall expire at the time that final judgment has been entered and/or any appeals have been resolved, of any matters filed and litigated as a result of actions taken during the 2023 Mississippi Legislative Session unless terminated earlier.

IT IS, THEREFORE, ORDERED, that the Mayor be authorized to execute an agreement with Public Rights Project to represent the City in the above referenced matters on a pro bono basis.

MARTIN, LUMUMBA

Agenda Item No. 35
May 23, 2023

Office of the City Attorney

455 East Capitol Street
Post Office Box 2779
Jackson, Mississippi 39207-2779
Telephone: (601) 960-1799
Facsimile: (601) 960-1756

OFFICE OF THE CITY ATTORNEY

This **ORDER AUTHORIZING THE MAYOR TO EXECUTE AN AGREEMENT WITH THE PUBLIC RIGHTS PROJECT TO REPRESENT THE CITY IN CHALLENGING THE LEGALITY OF ACTIONS TAKEN DURING THE 2023 MISSISSIPPI LEGISLATIVE SESSION** is legally sufficient for placement in NOVUS Agenda.



Carrie Johnson, Deputy City Attorney

5/17/2023
Date

#36

ORDER AUTHORIZING THE MAYOR TO EXECUTE A RENEWAL CONTRACT WITH TIM HOWARD TO PROVIDE INDIGENT DEFENDER LEGAL SERVICES FOR THE CITY OF JACKSON, MISSISSIPPI

WHEREAS, the City Council previously authorized a contract between the City of Jackson and Tim Howard for a period of 6 months and said period will expire on May 31, 2023; and

WHEREAS, pursuant to Section 21-23-7(4) of the Mississippi Code of 1972 (as amended), when a person is charged with an offense in municipal court punishable by confinement, the municipal judge, being satisfied that such person is an indigent person and is unable to employ counsel, may, in the discretion of the court, appoint counsel and compensation for appointed counsel in criminal cases shall be approved and allowed by the municipal judge and shall be paid by the municipality; and

WHEREAS, the City Council previously authorized a contract between the City of Jackson and Metro Public Defender Office to provide professional legal services to indigent criminal defendants as required by law; and

WHEREAS, the Office of the City Attorney in consultation with the Office of the City Prosecutor and municipal court judges, determined there is a need for additional attorneys to ensure representation of indigent defendants in cases arising within Municipal Court, in Jackson, Mississippi; and

WHEREAS, pursuant to Section 21-23-7(4) of the Mississippi Code of 1972 (as amended), the maximum compensation provided for representation shall not exceed Two Hundred Dollars (\$200.00) for any one (1) case and the governing authorities of a municipality may, in their discretion, appoint a public defender(s) who must be a licensed attorney and who shall receive a salary to be fixed by the governing authorities; and

WHEREAS, the Office of the City Attorney recommends the City of Jackson execute a renewal contract with Tim Howard for (1) year with an option to renew said contract for additional terms in an amount not to exceed \$5,000.00 per month to represent indigent defendants in cases arising within the Municipal Court, Jackson, Mississippi.

IT IS, THEREFORE, ORDERED that the Mayor is authorized to execute a renewal contract with Tim Howard to provide professional legal services for certain indigent defendants charged with misdemeanor offenses in Jackson Municipal Court in the contract amount of \$5,000.00 per month or less.

IT IS FURTHER ORDERED that the Mayor is authorized to execute any other documents that are necessary to effectuate the intent of this order.

Agenda Item No. 36
May 23, 2023
(C. Martin, Lumumba)

Office of the City Attorney

455 East Capitol Street
Post Office Box 2779
Jackson, Mississippi 39207-2779
Telephone: (601) 960-1799
Facsimile: (601) 960-1756

OFFICE OF THE CITY ATTORNEY

This **ORDER AUTHORIZING THE MAYOR TO EXECUTE A RENEWAL CONTRACT WITH TIM HOWARD TO PROVIDE INDIGENT DEFENDER LEGAL SERVICES FOR THE CITY OF JACKSON, MISSISSIPPI** is legally sufficient for placement in NOVUS Agenda.



Carrie Johnson, Deputy City Attorney

5/17/2023

Date

#37

ORDER AUTHORIZING PAYMENT OF \$30,000.00 TO THE ESTATE OF REGUS MCCULLEN AS FULL AND COMPLETE SETTLEMENT OF PROPERTY CLAIM.

OFFICE OF THE CITY ATTORNEY
JACKSON, MISSISSIPPI

WHEREAS, on April 11, 2022, sewage began to back up into the home located at 4555 Raymond Road, Jackson, Mississippi, owned by the Estate of Regus McCullen and occupied by Jacqueline McCullen, causing damage to flooring, walls, bathtub, carpet and personal items; and

WHEREAS, the City Attorney's office has determined that compromising the claim is in the best interest of the City of Jackson as claimant had previous reports of sewage backup; and

WHEREAS, pursuant to the current consent decree, the City of Jackson paid for the clean up to the residence located at 4555 Raymond Road, Jackson, Mississippi, in the amount of \$6,633.76 for the April 11, 2022 incident; and

WHEREAS, the home owner incurred costs associated with the sewage backup which includes: repair/replacement to carpet, floors, sheet rock, fixtures, furniture, temporary housing and replacement of other personal items.

IT IS HEREBY ORDERED that payment in the amount of \$30,000.00 be made to Regus McCullen Estate, as a compromised full and complete settlement for any and all claims resulting from property damage and expenses related to the incident that occurred on April 11, 2022, due to sewage backup into the residence located at 4555 Raymond Road, Jackson, Mississippi.

(MARTIN, LUMUMBA)

Agenda Item No. 37
May 23, 2023

CITY COUNCIL AGENDA ITEM 10 POINT DATA SHEET

04/19/2023
DATE

P O I N T S		C O M M E N T S								
1.	1. Brief Description/Purpose	ORDER AUTHORIZING PAYMENT OF \$30,000.00 TO THE ESTATE OF REGUS MCCULLEN AS FULL AND COMPLETE SETTLEMENT OF PROPERTY CLAIM.								
2.	Public Policy Initiative 2. Crime Prevention 3. Changes in City Government 4. Neighborhood Enhancement 5. Economic Development 6. Infrastructure and Transportation 7. Quality of Life	N/A								
3.	Who will be affected	City of Jackson								
4.	Benefits	N/A								
5.	Schedule (beginning date)	N/A								
6.	Location: ▪ WARD ▪ CITYWIDE (yes or no) (area) ▪ Project limits if applicable	N/A								
7.	Action implemented by: ▪ City Department <input checked="" type="checkbox"/> ▪ Consultant <input type="checkbox"/>	Office of the City Attorney								
8.	COST	\$30,000.00								
9.	Source of Funding ▪ General Fund <input checked="" type="checkbox"/> ▪ Grant <input type="checkbox"/> ▪ Bond <input type="checkbox"/> ▪ Other <input type="checkbox"/>									
10.	EBO participation	ABE	_____ %	WAIVER	yes	___	no	___	N/A	<u> X </u>
		AABE	_____ %	WAIVER	yes	___	no	___	N/A	<u> X </u>
		WBE	_____ %	WAIVER	yes	___	no	___	N/A	<u> X </u>
		HBE	_____ %	WAIVER	yes	___	no	___	N/A	<u> X </u>
		NABE	_____ %	WAIVER	yes	___	no	___	N/A	<u> X </u>

MEMO

TO: Carrie Johnson, Senior Deputy City Attorney
Office of the City Attorney

DATE: April 19, 2023

RE: Settlement of Property Claim for Administrators of the Estate of Regus McCullen (14559-VC)

Claimant states on 04/11/2022 sewer backed up into the home located at 4555 Raymond Road causing damage to the flooring, bedrooms, clothes, shoes and etc. Claimant is seeking reimbursement for repairs to the home, replacement of personal items and reimbursement for rent paid for temporary housing as she could not stay in her home for months due to the hazardous conditions.

Per Sewer Maintenance and 311 calls the homeowner has made calls and complaints dating back to 2017 concerning tree stump and roots in the line causing sewer backups.

It is hereby recommended, pending City Council approval, that the City of Jackson accepts the aforementioned payment in the amount of \$30,000 as a compromised settlement for payment.



MacDarrell Poullard, Risk Manager
Risk Management Division

MDP/tbp

Attachments

RECEIVED
APR 19 2023
OFFICE OF THE CITY ATTORNEY

FILED
JUN 03 2016

**IN THE CHANCERY COURT OF THE FIRST JUDICIAL DISTRICT
OF HINDS COUNTY, MISSISSIPPI**

EDDIE JEAN CARR, CHANCERY CLERK
BY [Signature] D.C.

**IN THE MATTER OF THE ESTATE OF
REGUS MCCULLEN, DECEASED**

CAUSE NO. P2016-225 W/4

LETTERS OF ADMINISTRATION

**STATE OF MISSISSIPPI
COUNTY OF HINDS**

WHEREAS, JACQUELINE B. MCCULLEN and TAHEYANNA Y. BUTLER have been appointed, by this Court as Co-Administrators of the Estate of Regus McCullen, deceased.

WE, THEREFORE, BY THESE LETTERS, authorize JACQUELINE B. MCCULLEN and TAHEYANNA Y. BUTLER, as Co-Administrators as aforesaid, to discharge all the duties required of them by law or by the Order of this Court.

WITNESS, Honorable PATRICIA D. WISE of the Chancery Court of the First Judicial District of Hinds County, Mississippi, on the 31st day of May in the year of our Lord one thousand nine hundred and sixteen (2016), the seal of said Court hereunto affixed.



3rd day of June, 2016.

EDDIE JEAN CARR, Chancery Clerk
By [Signature]
D.C.

I, Eddie Jean Carr, Clerk of the Chancery Court in and for the First Judicial District of Hinds County, Mississippi, certify that the above is a true copy of the Letters of Administration upon the Estate of Regus McCullen, deceased granted, and issued to Jacqueline B. McCullen and Taheyanna Y. Butler, Co-Administrators, on the 31st day of May, 2016, as the same appears on file and of record in my office, in Jackson, in said county and state.

GIVEN under my hand and the seal of said Court at Jackson, Mississippi, in said County, Mississippi, this the 3rd day of June, 2016.



EDDIE JEAN CARR, Chancery Clerk
By [Signature] D.C.

Regus & Jacqueline McCullen File #14559

AFFIDAVIT CONCERNING PROPERTY INSURANCE

I, **JACQUELINE MCCULLEN**, do hereby swear and affirm upon oath that the following statements are true and correct to the best of my knowledge:

1. I reside in Hinds County, Mississippi, and I am above the age of 21 years;
2. I have not previously been convicted of a crime concerning the swearing or giving of false statements under oath;
3. I currently reside at 4555 Raymond Road, Jackson, MS 39212 which is listed on the Hinds County Landroll as Parcel Number 848-150-1 with the assessed owner being McCullen Regus Estate.
4. On or about April 11, 2022 raw sewage entered 4555 Raymond Road and caused damage to a bedroom, shoe and clothes.
5. I filed a Report of property Damage with the City of Jackson dated April 18, 2022. I indicated on said report that I did not file with any insurance carrier regarding damage received due to the sewage backup on April 11, 2022.
6. As of the signing of this Affidavit I have not filed a claim with any insurance company for damage received due to the sewage backup on April 11, 2022; nor have I received any insurance funds for damage received due to the sewage backup on April 11, 2022.

JACQUELINE MCCULLEN

STATE OF MISSISSIPPI
COUNTY OF HINDS

Personally appeared before me the undersigned authority in and for the jurisdiction aforesaid, **JACQUELINE MCCULLEN**, who swore upon oath that the statements contained within the above and foregoing affidavit are true and correct to the best of her knowledge.

Sworn and subscribed to before me on this the 20 day of March, 2023.

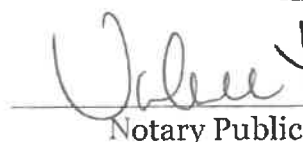
Notary Public

My Commission expires: Nov. 17, 2023



Regus & Jacqueline McCullen File #14559

AFFIDAVIT CONCERNING PROPERTY INSURANCE

I, **TAHEYANNA Y. BUTLER**, do hereby swear and affirm upon oath that the following statements are true and correct to the best of my knowledge:

1. I reside in Hinds County, Mississippi, and I am above the age of 21 years;
2. I have not previously been convicted of a crime concerning the swearing or giving of false statements under oath;
3. I currently reside at 4555 Raymond Road, Jackson, MS 39212 which is listed on the Hinds County Landroll as Parcel Number 848-150-1 with the assessed owner being McCullen Regus Estate.
4. On or about April 11, 2022 raw sewage entered 4555 Raymond Road and caused damage to a bedroom, shoe and clothes.
5. I filed a Report of property Damage with the City of Jackson dated April 18, 2022. I indicated on said report that I did not file with any insurance carrier regarding damage received due to the sewage backup on April 11, 2022.
6. As of the signing of this Affidavit I have not filed a claim with any insurance company for damage received due to the sewage backup on April 11, 2022; nor have I received any insurance funds for damage received due to the sewage backup on April 11, 2022.



TAHEYANNA Y. BUTLER

STATE OF MISSISSIPPI
COUNTY OF HINDS

Personally appeared before me the undersigned authority in and for the jurisdiction aforesaid, **TAHEYANNA Y. BUTLER**, who swore upon oath that the statements contained within the above and foregoing affidavit are true and correct to the best of her knowledge.

Sworn and subscribed to before me on this the 25th day of April, 2023.

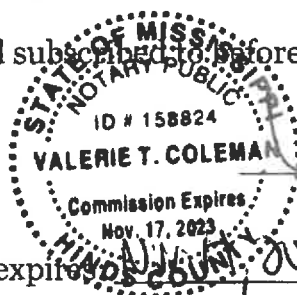



Notary Public

My Commission expires 08/20/23



OFFICE OF THE CITY ATTORNEY
Risk Management Division

March 29, 2023

Administrators of the Estate of Regus McCullen
4555 Raymond Road
Jackson, MS 39212

RECEIVED

APR 04 2023

RE: Claim for Damages against the City of Jackson
Claim Number: 14559
Date of Incident: 04/11/2022
Description of Claim: Property Damage

RISK MANAGEMENT DIVISION

Dear Administrators of the Estate of Regus McCullen:

On April 18, 2022, the Risk Management Division received your claim regarding damage allegedly sustained to your property on April 11, 2022. The claim has been investigated, and the Risk Management Division hereby indicates a willingness to recommend that the governing authorities settle the claim for the sum of \$30,000.00 for repairs to real property, personal property and temporary living residence. The settlement recommendation is subject to the approval of the governing authorities for the City of Jackson.

The Risk Management Division willingness to recommend settlement of the claim should not be construed as an admission of liability. The recommendation for the settlement stems from a recognition that the City's best interest would be served by settlement as oppose to litigation. Moreover, the Risk Management Division willingness to recommend settlement of the claim should *not* be construed as a waiver of any requirement contained within the provisions of the Mississippi Tort Claims Act, including but not limited to the filing of a Notice of Claim or the time for filing suit.

Assuming the governing authorities consent and approve settlement by the payment of the above stated sum, we will require you to sign a release. You may be also required to complete a W9 form for processing of the settlement proceeds. Please acknowledge by signature below your receipt and understanding of the contents of this letter and return to the Risk Management Division. If you have any questions, please feel free to contact me at 601-960-0521 or vcoleman@jacksonms.gov.

Sincerely,

Valerie T. Coleman, Claims Supervisor
Risk Management Division

Acknowledgement and Receipt Section

I, Administrators of the Estate of Regus McCullen, certify that I have read and understand the contents stated in this letter. I hereby accept the amount offered herein to settle my claim with the understanding that said offer of settlement is contingent upon the consent and approval of the governing authorities of the City of Jackson.

Jacqueline B. McCullen

Taheyanna Y. Butler

04-03-23
Date
04-03-2023
Date

2 PM
14/22

Nerhus Properties Inc.
Customer QuickReport
March 1 through November 14, 2022

Type	Date	Num	Memo	Account	Ctr	Split	Debit	Credit
Janeline Butler								
Invoice	03/01/2022	22025		Accounts Receivable		414 Apartmen...	1,500.00	
Payment	03/01/2022	0819005973		Renasant - Plaza	X	Accounts Rec...	1,500.00	
Invoice	04/01/2022	22057		Accounts Receivable		414 Apartmen...	1,500.00	
Payment	04/08/2022	0819006067		Renasant - Plaza	X	Accounts Rec...	1,500.00	
Invoice	05/01/2022	22085		Accounts Receivable		414 Apartmen...	1,500.00	
Payment	05/05/2022	0822002712		Renasant - Plaza	X	Accounts Rec...	1,500.00	
Invoice	06/01/2022	22128		Accounts Receivable		414 Apartmen...	1,500.00	
Payment	06/10/2022	28191543276		Renasant - Plaza	X	Accounts Rec...	500.00	
Payment	06/10/2022	28191543265		Renasant - Plaza	X	Accounts Rec...	1,000.00	
Invoice	07/01/2022	22155		Accounts Receivable		414 Apartmen...	1,500.00	
Payment	07/06/2022	0819006281		Renasant - Plaza	X	Accounts Rec...	1,500.00	
Invoice	08/01/2022	22186		Accounts Receivable		414 Apartmen...	1,500.00	
Payment	08/09/2022	0819006334		First Commercial -...	X	Accounts Rec...	1,500.00	
Invoice	09/01/2022	22214		Accounts Receivable		414 Apartmen...	1,500.00	
Payment	09/12/2022	19-433158817		First Commercial -...	X	Accounts Rec...	500.00	
Payment	09/12/2022	19-433158816		First Commercial -...	X	Accounts Rec...	1,000.00	
Invoice	10/01/2022	22255		Accounts Receivable		414 Apartmen...	1,500.00	
Payment	10/12/2022	19-441782427		First Commercial -...	X	Accounts Rec...	1,000.00	
Payment	10/12/2022	19-441782428		First Commercial -...	X	Accounts Rec...	500.00	
Invoice	11/01/2022	22284		Accounts Receivable		414 Apartmen...	1,500.00	

RECEIVED

NOV 14 2022

RISK MANAGEMENT DIVISION



12/6/22
Payments made for
rental property as she
cannot stay in her home.

Va

REQUEST / LOCATION INFORMATION			
Request ID:	205887	Date Created:	9/25/2017 2:20:01 PM
Request Code:	SM_SEWERLEAKINSIDE	Request Description:	SEWER LEAK/OVERFLOW - INSIDE
Priority	High	Request Status:	Closed
Submit To:	SEWERMAINT,	Request Created By:	BRITTAIN, CASITA
Dispatch To:			
Incident Address:	4555 RAYMOND ROAD		
Incident Apt Number:		Incident City:	Jackson
Boundary:		Precinct:	I
Ward:	4		

CUSTOMER CONTACT INFORMATION			
First Name	Last Name	Address	Apt. #
NACY	MCCULLAN	4555 RAYMOND ROAD	
City	Zip	Work Phone	Home Phone
JACKSON	39204		769 232 3574

QUESTIONS / ANSWERS	
Question	Answer
Is this a residence or business?	Residence
Where is the leak occuring?	House/Basement

DETAILS / COMMENTS/LOCATION	
Request Details:	The caller states a there is a tree stump in the manhole that was never removed, which is causing sewage to back up into her home.
Request Comments:	By MORRIS, CAROLYN M: 10/16/2017 9:57:55 AM 9/27/2017; Per PW-125 (A. Nelson), Unable to access sewer main line. The line is either broken down and possible roots in the line. Supervisor attention needed ASAP. No SSO. By SULLIVAN, SHARRON: 1/27/2022 12:39:23 PM CITIZEN STILL HAVING SAME CONCERN CALLED IN BY COUNCILMAN GRIZZELL OFFICE By MOORE, QUANKELA: 4/30/2022 10:58:54 AM Per Supervisor S. Bolden(PW-101) mainline stopped up on arrival, shot mainline 85ft N, mainline down and running, no SSO present at manhole or clean out. Talked to homeowner. By MOORE, QUANKELA: 5/6/2022 6:57:48 AM 4/30/2022 Per Supervisor S. Bolden(PW-101) mainline stopped up on arrival, shot mainline 85ft N, mainline down and running, no SSO present at manhole or clean out. Talked to homeowner.
Location:	

EMPLOYEE COMMENTS

REQUEST / LOCATION INFORMATION			
Request ID:	235147	Date Created:	11/9/2018 10:22:20 AM
Request Code:	SM_SEWERLEAKINSIDE	Request Description:	SEWER LEAK/OVERFLOW - INSIDE
Priority:	High	Request Status:	Closed
Submit To:	SEWERMAINT,	Request Created By:	JENKINS, ALICIA
Dispatch To:			
Incident Address:	4555 RAYMOND RD		
Incident Apt Number:		Incident City:	JACKSON
Boundary:		Precinct:	1
Ward:	4		

CUSTOMER CONTACT INFORMATION			
First Name	Last Name	Address	Apt. #
MS.	MCCULLEN	4555 RAYMOND ROAD	

City	Zip	Work Phone	Home Phone
JACKSON	39204		769-232-3574

QUESTIONS / ANSWERS	
Question	Answer
Is this a residence or business?	Residence
Where is the leak occuring?	Toilet

DETAILS /COMMENTS/LOCATION	
Request Details:	Caller states sewage is backing up in to her tub and toilets. Check for a choke.
Request Comments:	By JENKINS, ALICIA: 11/9/2018 2:36:00 PM Per R. Harper (PW118); Main line is down and running with no SSO to report. Caller is not satisfied with the decision, therefore Supervisor D. Davis was notified to go and check out the location at a later time (today or tomorrow). By BRITTAIN, CASITA: 11/13/2018 5:32:24 AM 11/9/18 - R. Harper (PW118): Owner needs a plumber, all manholes are down and running. By MOORE, QUANKELA: 11/20/2018 9:10:04 PM Per PW-118(R. Harper) Mainline down and running, caller wanted the clean out shot. By JENKINS, ALICIA: 11/21/2018 11:28:33 AM Caller called again on this morning and said that her issue is not resolved. I told her we would send a Jet Truck out again to check the City line. By JENKINS, ALICIA: 11/22/2018 12:07:04 PM Per Supervisor D. Davis; we have went out there several times and the owner basically wants her service line shot which is something we can't do. By BRITTAIN, CASITA: 12/4/2018 1:31:50 PM Per A. Nelson (PW125): Unchoked the main line 50ft South. Main line down and running, no SSO. The main line needs attention from a Construction Supervisor there are tree roots and a stump in the line. By BRITTAIN, CASITA: 12/9/2018 12:51:33 AM 12/4/18 - A. Nelson (PW125): Unchoked main line, main line down and running. Manhole has a stump roots, refer to construction Supervisor, PW-101

on site. By BRITTAIN, CASITA: 9/29/2019 11:14:05 PM Per N. Mack (PW114); Shot the main 150ft past location, mains are down and running, no SSO. By BRITTAIN, CASITA: 10/7/2019 1:57:08 AM 9/29/19 - N. Mack (PW114): Shot City main line 150ft pass location. Main line down and running, no SSO.

Location:

EMPLOYEE COMMENTS



REQUEST / LOCATION INFORMATION			
Request ID:	261109	Date Created:	11/29/2019 12:07:28 PM
Request Code:	SM_SEWERLEAKINSIDE	Request Description:	SEWER LEAK/OVERFLOW - INSIDE
Priority:	High	Request Status:	Closed
Submit To:	SEWERMAINT,	Request Created By:	MORRIS, CAROLYN M
Dispatch To:			
Incident Address:	4555 RAYMOND RD		
Incident Apt Number:		Incident City:	JACKSON
Boundary:		Precinct:	1
Ward:	4		

CUSTOMER CONTACT INFORMATION			
First Name	Last Name	Address	Apt. #
MS.	MCCULLEN	4555 RAYMOND RD	

City	Zip	Work Phone	Home Phone
JACKSON	39204		769-232-3574

QUESTIONS / ANSWERS

Question	Answer
Is this a residence or business?	Residence
Where is the leak occurring?	House/Basement

DETAILS /COMMENTS/LOCATION

Request Details:	Caller states sewage is backing up into her tub and toilets. It has been reported that there is a stump roots in the manhole causing her line to back up. See Id#235147
Request Comments:	By MORRIS, CAROLYN M: 11/30/2019 2:06:05 PM Per PW-136 (T. McDonald), took cap off clean-out, there is a tree stump in manhole. By JENKINS, ALICIA: 12/11/2019 2:07:31 PM Per J. Bell (PW119), assisted Supervisor T. Robinson (PW100) at this location. There was no SSO. By JENKINS, ALICIA: 12/12/2019 7:33:46 AM Per Supervisor T. Robinson (PW100), cut the roots out of the manhole at this location. The jet truck will need to go back and shoot the service line to unstop it. By MOORE, QUANKELA: 12/14/2019 2:32:33 PM Per PW-119(J. Bell) As requested by Supervisor T. Robinson(PW-100) shot the service line. No SSO. By MOORE, QUANKELA: 12/22/2019 1:45:11 PM . 12/11/19 Per J. Bell (PW119), assisted Supervisor T. Robinson (PW100) at this location. There was no SSO. By MOORE, QUANKELA: 12/22/2019 1:56:22 PM . 12/14/19 Per PW-119(J. Bell) As requested by Supervisor T. Robinson(PW-100) shot the service line. No SSO. By MOORE, QUANKELA: 12/29/2019 3:00:19 PM Per Supervisor T. Robinson(PW-100) Shot service line to unchoke, manhole had been covered with roots, service line comes into the manhole, not the homeowners fault. Had crew to take out roots in the manhole 12/13/19.
Location:	

REQUEST / LOCATION INFORMATION			
Request ID:	263425	Date Created:	1/9/2020 1:31:34 PM
Request Code:	SM_SEWERLEAKOUTSIDE	Request Description:	SEWER LEAK/OVERFLOW - OUTSIDE
Priority:	High	Request Status:	Pending
Submit To:	SEWERMAINT,	Request Created By:	MORRIS, CAROLYN M
Dispatch To:			
Incident Address:	4555 RAYMOND RD		
Incident Apt Number:		Incident City:	JACKSON
Boundary:		Precinct:	1
Ward:	4		

CUSTOMER CONTACT INFORMATION			
First Name	Last Name	Address	Apt. #
MS.	MCCULLEN	4555 RAYMOND RD	

City	Zip	Work Phone	Home Phone
JACKSON	39204		769-232-3574

QUESTIONS / ANSWERS	
Question	Answer
Is this a residence or business?	Residence
Where is the leak occurring?	Yard
Does the leak have an odor?	YES

DETAILS /COMMENTS/LOCATION	
Request Details:	Sewage flowing into yard.
Request Comments:	By MORRIS, CAROLYN M: 1/9/2020 3:48:49 PM Per PW-102 (D. Thomas), the owner has roots in the service line. The city's main line is down and running, There is signs of a previous SSO at the Clean-out. Notified DEQ @ 3:48 p.m. By BRITTAIN, CASITA: 3/19/2020 12:33:20 PM Ms. McCullen called back and requested for someone to come to clean up the sewage debris and put out disinfect.
Location:	

EMPLOYEE COMMENTS

REQUEST / LOCATION INFORMATION			
Request ID:	263585	Date Created:	1/12/2020 9:27:49 AM
Request Code:	SM_SEWERMAINCHOKED	Request Description:	SEWER MAIN CHOKED
Priority:	High	Request Status:	Closed
Submit To:	SEWERMAINT,	Request Created By:	MORRIS, CAROLYN M
Dispatch To:			
Incident Address:	4555 RAYMOND RD		
Incident Apt Number:		Incident City:	JACKSON
Boundary:		Precinct:	1
Ward:	4		

CUSTOMER CONTACT INFORMATION			
First Name	Last Name	Address	Apt. #
NANCY	MCCULLAN	4555 RAYMOND RD	

City	Zip	Work Phone	Home Phone
JACKSON	39204		769 232 3574

QUESTIONS / ANSWERS	
Question	Answer
Please describe the problem.	choke main line

DETAILS /COMMENTS/LOCATION	
Request Details:	Check main line for choke causing back up on the inside.
Request Comments:	By MORRIS, CAROLYN M: 1/12/2020 9:36:16 AM Per PW-1002 (D. Thomas), we was unable to open the service from the manhole, due to roots infiltration in the service line about 15 ft. Northeast. Advised the homeowner's son to re-route the service to the manhole in the yard.
Location:	

EMPLOYEE COMMENTS

REQUEST / LOCATION INFORMATION			
Request ID:	266721	Date Created:	2/27/2020 2:33:06 PM
Request Code:	SM_SEWERLEAKINSIDE	Request Description:	SEWER LEAK/OVERFLOW - INSIDE
Priority:	High	Request Status:	Closed
Submit To:	SEWERMAINT,	Request Created By:	BRITTAIN, CASITA
Dispatch To:			
Incident Address:	4555 RAYMOND RD		
Incident Apt Number:		Incident City:	JACKSON
Boundary:		Precinct:	1
Ward:	4		

CUSTOMER CONTACT INFORMATION			
First Name	Last Name	Address	Apt. #
MARY	CARTER	4555 RAYMOND ROAD	
City	Zip	Work Phone	Home Phone
JACKSON	39204		EXT. 1196

QUESTIONS / ANSWERS	
Question	Answer
Is this a residence or business?	Residence
Where is the leak occurring?	House/Basement

DETAILS /COMMENTS/LOCATION	
Request Details:	Per Mary Carter's email; send a truck out to this location to check the main lines, the homeowner has problems in the home.
Request Comments:	By MOORE, QUANKELA: 3/2/2020 11:26:31 AM Per PW-127(D. Stratton) Mainline down and running. Caller will need a plumber. Spoke to the caller, also put out disinfectant the caller already had.
Location:	

EMPLOYEE COMMENTS

REQUEST / LOCATION INFORMATION			
Request ID:	267452	Date Created:	3/13/2020 5:50:23 PM
Request Code:	SM_SEWERLEAKOUTSIDE	Request Description:	SEWER LEAK/OVERFLOW - OUTSIDE
Priority:	High	Request Status:	Closed
Submit To:	SEWERMAINT,	Request Created By:	JENKINS, ALICIA
Dispatch To:			
Incident Address:	4555 RAYMOND RD		
Incident Apt Number:		Incident City:	JACKSON
Boundary:		Precinct:	1
Ward:	4		

CUSTOMER CONTACT INFORMATION			
First Name	Last Name	Address	Apt. #
PER DAN	THOMAS	4555 RAYMOND ROAD	

City	Zip	Work Phone	Home Phone
JACKSON	39204		ext.2133
			769-232-3574
JACKSON	39204		769-232-3574

QUESTIONS / ANSWERS	
Question	Answer
Is this a residence or business?	Residence
Where is the leak occurring?	Cleanout
Is the cleanout located next to the street or the house?	Street
Does the leak have an odor?	NO

DETAILS /COMMENTS/LOCATION	
Request Details:	Per Dan Thomas, wash down and clean up the yard around the clean out. Also, disinfect the area.
Request Comments:	By BRITTAIN, CASITA: 3/20/2020 12:28:47 PM By BRITTAIN, CASITA: 3/19/2020 12:33:20 PM Ms. McCullen called back and requested for someone to come to clean up the sewage debris and put out disinfect. By BRITTAIN, CASITA: 3/20/2020 12:29:41 PM New Inquiry: 2nd request for Ms. McCullum for disinfect to put in her yard. By JENKINS, ALICIA: 3/26/2020 9:36:38 PM Per J. Bell (PW119), main line down and running with no SSO. Wash down and also put out disinfectant in callers yard. Was able to speak to the caller. By MOORE, QUANKELA: 4/3/2020 5:39:45 AM 3/26/2020 Per J. Bell (PW119), main line down and running with no SSO. Wash down and also put out disinfectant in callers yard. Was able to speak to the caller.
Location:	

EMPLOYEE COMMENTS

REQUEST / LOCATION INFORMATION			
Request ID:	316439	Date Created:	10/19/2022 4:41:15 PM
Request Code:	SM_SEWERLEAKOUTSIDE	Request Description:	SEWER LEAK/OVERFLOW - OUTSIDE
Priority:	High	Request Status:	Open
Submit To:	SEWERMAINT,	Request Created By:	FORTSON, MELBA
Dispatch To:			
Incident Address:	4555 RAYMOND RD		
Incident Apt Number:		Incident City:	
Boundary:		Precinct:	I
Ward:	4		

CUSTOMER CONTACT INFORMATION			
First Name	Last Name	Address	Apt. #
WILLIAM	NORMAN	4555 RAYMOND ROAD	

City	Zip	Work Phone	Home Phone
			601-421-7597
JACKSON	39204		769 232-3574

QUESTIONS / ANSWERS

Question	Answer
Is this a residence or business?	Residence
Where is the leak occurring?	Manhole (round top)
Does the leak have an odor?	YES

DETAILS /COMMENTS/LOCATION

Request Details:	Caller called on behalf of the homeowner to report a manhole overflowing with sewage flooding onto her property.
Request Comments:	By MOORE, QUANKELA: 10/27/2022 12:37:21 AM 10/22/22 Per PW-140(W. Love) the manhole is not overflowing, it is holding. This location may be tied to 157 Ramada Cir. The mainline is broke in the woods behind this location. By MOORE, QUANKELA: 10/27/2022 8:20:05 AM - CALL BACK- Ms. J McCullen, 769-232-3574 Caller asking when someone will come to clean out the manhole and asking for something for the smell. By MOORE, QUANKELA: 10/27/2022 11:26:56 AM Per PW-140(W. Love) manhole holding, ongoing SSO from the clean out. Disinfectant and sign put out at location. Extra disinfectant left out for callers at her door as a one time courtesy. DEQ notified at 11:26a.m. By JOHNSON, CELESTE: 10/27/2022 12:52:29 PM NEW INQUIRY, REC'D 10/27/2022. By MOORE, QUANKELA: 10/28/2022 12:06:54 PM -CALL BACK- Ms. J McCullen states the manhole in front of her home needs to be blown out. By MOORE, QUANKELA: 10/31/2022 2:08:19 PM 10/27/2022 Per PW-140(W. Love) manhole is choked up and ongoing SSO from the clean out, ongoing problem. By MOORE, QUANKELA: 11/16/2022 1:14:10 PM Caller requesting disinfectant for this location. By MOORE, QUANKELA: 11/21/2022 8:29:26 AM -CALL BACK- Ms. J McCullen states the manhole in front of her home needs to be blown out.
Location:	

EMPLOYEE COMMENTS

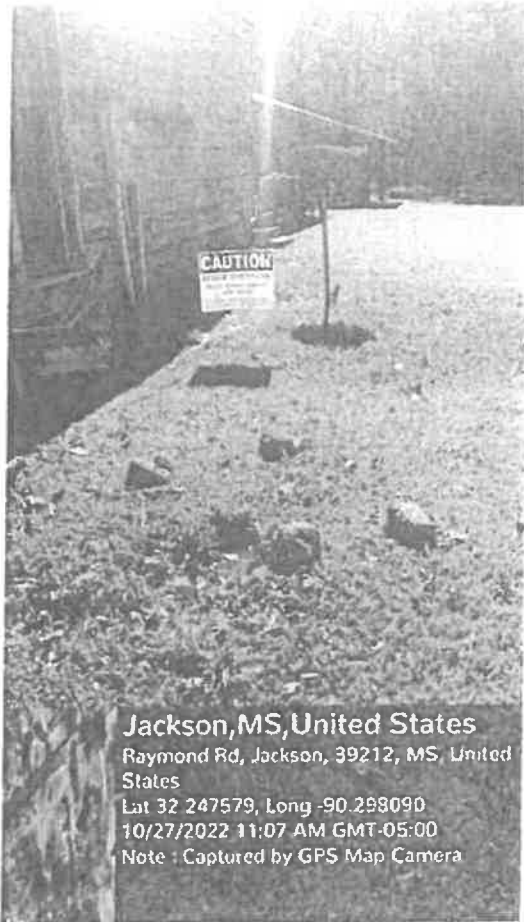

Jackson,MS,United States
Raymond Rd, Jackson, 39212, MS, United States
Lat 32.247579, Long -90.298090
10/27/2022 11:07 AM GMT-05:00
Note : Captured by GPS Map Camera



Jackson,MS,United States
Raymond Rd, Jackson, 39212, MS, United States
Lat 32.247523, Long -90.298105
10/27/2022 10:41 AM GMT-05:00
Note : Captured by GPS Map Camera



Jackson,MS,United States
Raymond Rd, Jackson, 39212, MS, United States
Lat 32.247551, Long -90.298123
10/27/2022 10:41 AM GMT-05:00
Note : Captured by GPS Map Camera

L&P PROPERTY LLC

**Lower level Estimate:
Jacqueline McCullen 4549
Raymond Rd. Jackson MS 39212**

**Email:
bjacqueline237@gmail.com**

RECEIVED

MAY 12 2012

RISK MANAGEMENT DIVISION
Manager: Lonnie Wilson
711 Brookwood Circle.
Brandon, MS 39042
phone: 601-906-7428
Email: rso37@bellsouth.net

Description			
Downstairs Bathroom:			
Remove and replace flooring, walls and baseboard			
Remove and replace tub, sink and toilet			
Remove and replace all electrical wiring and fixtures			

Description			
Downstairs room(s) and closet(s):			
Remove and replace all electrical outlets			
Paint two coats (one color) on all interior walls			
Remove and replace all floors			
Remove and replace all base boards			
Remove and replace drywall on all walls			

Description			
		Lower level:	\$ 22,860.00

***Make all checks payable to Lonnie Wilson.

CLAIM NO	MIN BOOK	PAGE
828310	6V	139

ACCOUNT PAYABLE

VENDOR NUMBER	VENDOR NAME	CHECK NUMBER	CHECK DATE	CHECK AMOUNT
999993	JACQUELINE MCCULLEN	828310	06/07/2022	\$6,633.76

INVOICE DATE	INVOICE NUMBER	DESCRIPTION	INVOICE AMOUNT
05/13/2022	22720221013	JACQUELINE MCCULLEN R/I FOR SEWER CLEANUP	\$6,633.76

SY11037

myrausession.com 8/7/2020

RECEIVED
 JUN 08 2022
 RISK MANAGEMENT

FORM # PSCBEX (8-85)



City of Jackson, MS
 200 South Presidents Street
 Jackson, MS 39201

BANCORPSOUTH JACKSON, MS 85/127/8425 Vendor Number 999993 Check Number 828310 Check Date 06/07/2022

CLAIM NO	MIN BOOK	PAGE
828310	6V	139

NOT VALID AFTER 90 DAYS

*** Six Thousand Six Hundred And Thirty-Three Dollars And Seventy-Six Cents ***

\$6,633.76

999993
 Pay To JACQUELINE MCCULLEN
 The 4555 RAYMOND ROAD
 Order Of JACKSON, MS 39212

Ch. Ap. L.
 MAYOR

Tae Hander J. Hater
 DIRECTOR OF ADMINISTRATION

MP MP

00828310 084201278 0075993535

Memorandum of Understanding

TO: Whom It May Concern

RECEIVED

FROM: Jacqueline McCullen

MAY 27 2022

DATE: May 25, 2022

RISK MANAGEMENT DIVISION

RE: Claim for Damages Against the City of Jackson, Mississippi
Claim #: 14559
Location: 4555 Raymond Road
Jackson, MS 39212

This is to certify that I, Jacqueline McCullen, have the following understanding regarding the above captioned claim against the City of Jackson:

- Wallace Restoration Services, LLC (ServiceMaster Restore) will provide the clean-up work at my residence in the amount of \$6,633.76. The check will be made out in my name and I understand I am responsible for paying Wallace Restoration Services, LLC (ServiceMaster Restore).
- I understand the payment of the clean-up cost by the City of Jackson does not conclude that the City has accepted liability.
- In order to be compensated for my repair claim, a "City of Jackson Liability Reporting Claim Form" must be completed. Once the claim form is received in the Risk Management Division, an investigation will be conducted. Subsequent to the investigation, I will be advised, in writing, as to the disposition of my repair claim and any other damage. *Downstairs mother-in-law part only*

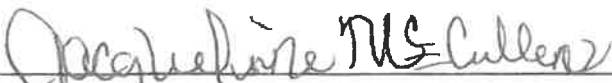

Jacqueline McCullen
4555 Raymond Road
Jackson, MS 39212



WALLACE RESTORATION SERVICES LLC

DBA: SERVICEMASTER BY CHUCK WALLACE
PO BOX 3878
Brookhaven Ms, 39603
601-835-1000
FIN # 27-4350694

INVOICE# 22720221013

Insured: JACQUELINE MCCULLEN
Property: 4555 RAYMOND RD
JACKSON, MS 39212

Home: (769) 232-3574

E-mail: BJACQUELINE237@GMAIL.
COM

Estimator: Charmagne Leggett

Claim Number:

Policy Number:

Type of Loss: Water Damage

Date Contacted: 5/13/2022 7:33 AM

Date of Loss:

Date Received: 5/13/2022 7:33 AM

Date Inspected: 5/13/2022 4:30 PM

Date Entered: 5/14/2022 7:47 AM

Price List: MSJA8X_MAY22
Restoration/Service/Remodel

Estimate: JACQUELINEMCCULLEN

Thank You for using ServiceMaster By Chuck Wallace, LLC for all of your cleaning and/or mitigation needs. Please note Fin # 27-4350694

WALLACE RESTORATION SERVICES LLC

DBA: SERVICEMASTER BY CHUCK WALLACE
PO BOX 3878
Brookhaven Ms, 39603
601-835-1000
FIN # 27-4350694

INVOICE# 22720221013

JACQUELINEMCCULLEN

Main Level

Main Level

DESCRIPTION	QTY	REMOVE	REPLACE	TAX	TOTAL
1. Emergency service call - during business hours	1.00 EA	0.00	161.44	0.00	161.44
3. Equipment setup, take down, and monitoring (hourly charge)	5.00 HR	0.00	57.10	0.00	285.50
4. Haul debris - per pickup truck load - including dump fees	4.50 EA	137.63	0.00	0.00	619.34
48. ESTIMATE FEE	1.00 EA	0.00	125.00	0.00	125.00
CUSTOMER PAID \$125.00 ESTIMATE FEE.					
Total: Main Level				0.00	1,191.28



BEDROOM

Height: 8'

466.67 SF Walls	165.28 SF Ceiling
631.94 SF Walls & Ceiling	165.28 SF Floor
18.36 SY Flooring	58.33 LF Floor Perimeter
58.33 LF Ceil. Perimeter	

DESCRIPTION	QTY	REMOVE	REPLACE	TAX	TOTAL
5. Tear out non-salv floating floor & bag - Category 3 water	165.28 SF	2.84	0.00	0.00	469.40
12. Tear out wet drywall, cleanup, bag - Cat 3	19.44 SF	1.43	0.00	0.00	27.80
19. Tear out baseboard and bag for disposal - up to Cat 3	58.33 LF	0.95	0.00	0.00	55.41
26. Tear out subfloor & bag for disposal - Category 3	165.28 SF	2.73	0.00	0.00	451.21
THERE IS A LAYER OF PLYWOOD OVER THE SUBFLOOR THAT NEEDS TO COME OUT, NOT SURE ON ACTUAL SUBFLOOR AS YOU CANT SEE IT TO DETERMINE DAMAGE UNTIL DEMO IS STARTED.					
33. Apply anti-microbial agent to more than the floor	223.61 SF	0.00	0.28	0.00	62.61
40. Air mover (per 24 hour period) - No monitoring	12.00 EA	0.00	29.50	0.00	354.00
4 FOR 3 DAYS					
Totals: BEDROOM				0.00	1,420.43

WALLACE RESTORATION SERVICES LLC

DBA: SERVICEMASTER BY CHUCK WALLACE
PO BOX 3878
Brookhaven Ms, 39603
601-835-1000
FIN # 27-4350694

INVOICE# 22720221013

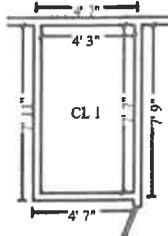

CL 1

Height: 8'

189.33 SF Walls	32.23 SF Ceiling
221.56 SF Walls & Ceiling	32.23 SF Floor
3.58 SY Flooring	23.67 LF Floor Perimeter
23.67 LF Ceil. Perimeter	

DESCRIPTION	QTY	REMOVE	REPLACE	TAX	TOTAL
6. Tear out non-salv floating floor & bag - Category 3 water	32.23 SF	2.84	0.00	0.00	91.53
13. Tear out wet drywall, cleanup, bag - Cat 3	7.89 SF	1.43	0.00	0.00	11.28
20. Tear out baseboard and bag for disposal - up to Cat 3	23.67 LF	0.95	0.00	0.00	22.49
27. Tear out subfloor & bag for disposal - Category 3	32.23 SF	2.73	0.00	0.00	87.99
THERE IS A LAYER OF PLYWOOD OVER THE SUBFLOOR THAT NEEDS TO COME OUT, NOT SURE ON ACTUAL SUBFLOOR AS YOU CANT SEE IT TO DETERMINE DAMAGE UNTIL DEMO IS STARTED.					
34. Apply anti-microbial agent to more than the floor	55.90 SF	0.00	0.28	0.00	15.65
41. Air mover (per 24 hour period) - No monitoring 1 FOR 3 DAYS	6.00 EA	0.00	29.50	0.00	177.00
Totals: CL 1				0.00	405.94



BATHROOM

Height: 8'

286.67 SF Walls	75.00 SF Ceiling
361.67 SF Walls & Ceiling	75.00 SF Floor
8.33 SY Flooring	35.83 LF Floor Perimeter
35.83 LF Ceil. Perimeter	

DESCRIPTION	QTY	REMOVE	REPLACE	TAX	TOTAL
7. Tear out non-salv floating floor & bag - Category 3 water	75.00 SF	2.84	0.00	0.00	213.00
14. Tear out wet drywall, cleanup, bag - Cat 3	11.94 SF	1.43	0.00	0.00	17.07
21. Tear out baseboard and bag for disposal - up to Cat 3	35.83 LF	0.95	0.00	0.00	34.04

WALLACE RESTORATION SERVICES LLC

DBA: SERVICEMASTER BY CHUCK WALLACE
PO BOX 3878
Brookhaven Ms, 39603
601-835-1000
FIN # 27-4350694

INVOICE# 22720221013

CONTINUED - TOILET

DESCRIPTION	QTY	REMOVE	REPLACE	TAX	TOTAL
Totals: TOILET				0.00	194.18

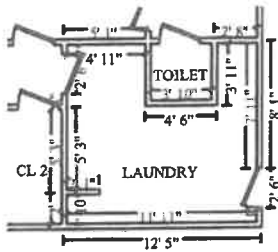

LAUNDRY

Height: 8'

468.00 SF Walls	116.68 SF Ceiling
584.68 SF Walls & Ceiling	116.68 SF Floor
12.96 SY Flooring	58.50 LF Floor Perimeter
58.50 LF Ceil. Perimeter	

DESCRIPTION	QTY	REMOVE	REPLACE	TAX	TOTAL
9. Tear out non-salv floating floor & bag - Category 3 water	116.68 SF	2.84	0.00	0.00	331.37
16. Tear out wet drywall, cleanup, bag - Cat 3	19.50 SF	1.43	0.00	0.00	27.89
23. Tear out baseboard and bag for disposal - up to Cat 3	58.50 LF	0.95	0.00	0.00	55.58
30. Tear out subfloor & bag for disposal - Category 3	116.68 SF	2.73	0.00	0.00	318.54
THERE IS A LAYER OF PLYWOOD OVER THE SUBFLOOR THAT NEEDS TO COME OUT, NOT SURE ON ACTUAL SUBFLOOR AS YOU CANT SEE IT TO DETERMINE DAMAGE UNTIL DEMO IS STARTED.					
37. Apply anti-microbial agent to more than the floor	175.18 SF	0.00	0.28	0.00	49.05
45. Air mover (per 24 hour period) - No monitoring	12.00 EA	0.00	29.50	0.00	354.00
4 FOR 3 DAYS					

Totals: LAUNDRY				0.00	1,136.43
-----------------	--	--	--	------	----------

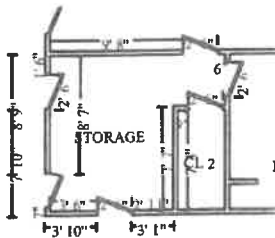

STORAGE

Height: 8'

384.00 SF Walls	115.29 SF Ceiling
499.29 SF Walls & Ceiling	115.29 SF Floor
12.81 SY Flooring	48.00 LF Floor Perimeter
48.00 LF Ceil. Perimeter	

DESCRIPTION	QTY	REMOVE	REPLACE	TAX	TOTAL
-------------	-----	--------	---------	-----	-------

WALLACE RESTORATION SERVICES LLC

DBA: SERVICEMASTER BY CHUCK WALLACE
PO BOX 3878
Brookhaven Ms, 39603
601-835-1000
FIN # 27-4350694

INVOICE# 22720221013

CONTINUED - STORAGE

DESCRIPTION	QTY	REMOVE	REPLACE	TAX	TOTAL
10. Tear out non-salv floating floor & bag - Category 3 water	115.29 SF	2.84	0.00	0.00	327.42
17. Tear out wet drywall, cleanup, bag - Cat 3	16.00 SF	1.43	0.00	0.00	22.88
24. Tear out baseboard and bag for disposal - up to Cat 3	48.00 LF	0.95	0.00	0.00	45.60
31. Tear out subfloor & bag for disposal - Category 3	115.29 SF	2.73	0.00	0.00	314.74
THERE IS A LAYER OF PLYWOOD OVER THE SUBFLOOR THAT NEEDS TO COME OUT, NOT SURE ON ACTUAL SUBFLOOR AS YOU CANT SEE IT TO DETERMINE DAMAGE UNTIL DEMO IS STARTED.					
38. Apply anti-microbial agent to more than the floor	163.29 SF	0.00	0.28	0.00	45.72
46. Air mover (per 24 hour period) - No monitoring 3 FOR 3 DAYS	9.00 EA	0.00	29.50	0.00	265.50
Totals: STORAGE				0.00	1,021.86

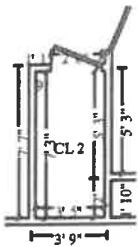

CL 2

Height: 8'

170.29 SF Walls	24.60 SF Ceiling
194.90 SF Walls & Ceiling	24.60 SF Floor
2.73 SY Flooring	21.29 LF Floor Perimeter
21.29 LF Ceil. Perimeter	

DESCRIPTION	QTY	REMOVE	REPLACE	TAX	TOTAL
11. Tear out non-salv floating floor & bag - Category 3 water	24.60 SF	2.84	0.00	0.00	69.86
18. Tear out wet drywall, cleanup, bag - Cat 3	7.10 SF	1.43	0.00	0.00	10.15
25. Tear out baseboard and bag for disposal - up to Cat 3	21.29 LF	0.95	0.00	0.00	20.23
32. Tear out subfloor & bag for disposal - Category 3	24.60 SF	2.73	0.00	0.00	67.16
THERE IS A LAYER OF PLYWOOD OVER THE SUBFLOOR THAT NEEDS TO COME OUT, NOT SURE ON ACTUAL SUBFLOOR AS YOU CANT SEE IT TO DETERMINE DAMAGE UNTIL DEMO IS STARTED.					
39. Apply anti-microbial agent to more than the floor	45.89 SF	0.00	0.28	0.00	12.85

WALLACE RESTORATION SERVICES LLC

DBA: SERVICEMASTER BY CHUCK WALLACE
 PO BOX 3878
 Brookhaven Ms, 39603
 601-835-1000
 FIN # 27-4350694

INVOICE# 22720221013

CONTINUED - CL 2

DESCRIPTION	QTY	REMOVE	REPLACE	TAX	TOTAL
47. Air mover (per 24 hour period) - No monitoring 1 FOR 3 DAYS	3.00 EA	0.00	29.50	0.00	88.50
Totals: CL 2				0.00	268.75
Total: Main Level				0.00	6,633.76
Line Item Totals: JACQUELINEMCCULLEN				0.00	6,633.76

Grand Total Areas:

2,083.63 SF Walls	542.82 SF Ceiling	2,626.45 SF Walls and Ceiling
542.82 SF Floor	60.31 SY Flooring	260.45 LF Floor Perimeter
0.00 SF Long Wall	0.00 SF Short Wall	260.45 LF Ceil. Perimeter
542.82 Floor Area	603.34 Total Area	2,119.63 Interior Wall Area
885.00 Exterior Wall Area	98.33 Exterior Perimeter of Walls	
0.00 Surface Area	0.00 Number of Squares	0.00 Total Perimeter Length
0.00 Total Ridge Length	0.00 Total Hip Length	

ServiceMASTER
Restore

WALLACE RESTORATION SERVICES LLC

DBA: SERVICEMASTER BY CHUCK WALLACE
PO BOX 3878
Brookhaven Ms, 39603
601-835-1000
FIN # 27-4350694

INVOICE# 22720221013

Summary for Dwelling

Line Item Total	6,633.76
Replacement Cost Value	<u>\$6,633.76</u>
Net Claim	<u>\$6,633.76</u>

Charmagne Leggett

ServiceMASTER
Restore

WALLACE RESTORATION SERVICES LLC

DBA: SERVICEMASTER BY CHUCK WALLACE
PO BOX 3878
Brookhaven Ms, 39603
601-835-1000
FIN # 27-4350694

INVOICE# 22720221013

Recap of Taxes

WALLACE RESTORATION SERVICES LLC

DBA: SERVICEMASTER BY CHUCK WALLACE
PO BOX 3878
Brookhaven Ms, 39603
601-835-1000
FIN # 27-4350694

INVOICE# 22720221013

Recap by Room

Estimate: JACQUELINEMCCULLEN

Area: Main Level	1,191.28	17.96%
BEDROOM	1,420.43	21.41%
CL 1	405.94	6.12%
BATHROOM	994.89	15.00%
TOILET	194.18	2.93%
LAUNDRY	1,136.43	17.13%
STORAGE	1,021.86	15.40%
CL 2	268.75	4.05%
<hr/>		
Area Subtotal: Main Level	6,633.76	100.00%
<hr/>		
Subtotal of Areas	6,633.76	100.00%
<hr/>		
Total	6,633.76	100.00%



WALLACE RESTORATION SERVICES LLC

DBA: SERVICEMASTER BY CHUCK WALLACE
PO BOX 3878
Brookhaven Ms, 39603
601-835-1000
FIN # 27-4350694

INVOICE# 22720221013

Recap by Category

Items	Total	%
GENERAL DEMOLITION	4,014.41	60.51%
WATER EXTRACTION & REMEDIATION	2,619.35	39.49%
Subtotal	6,633.76	100.00%

Main Level

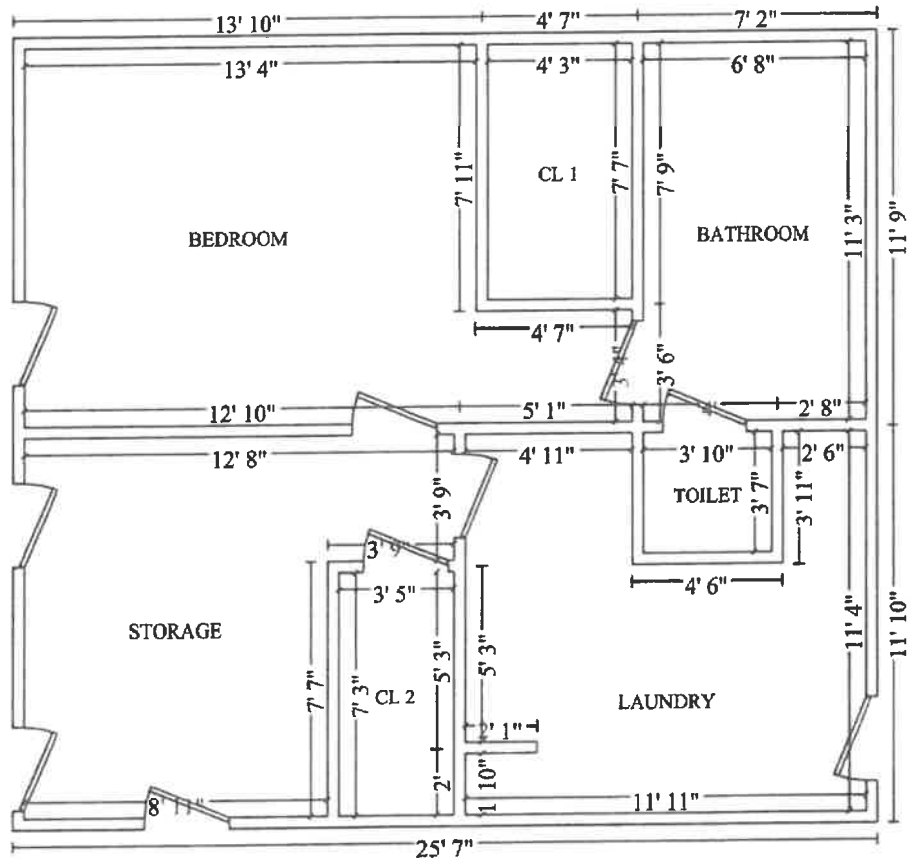

Main Level

Busy As A Bee Cleaning

ESTIMATE

PO BOX 3111
Jackson, Ms 39205
(901) 490-9101
busyasabee1@gmail.com

RECEIVED

MAY 12 2022

Bill To
Regus & Jacqueline McCullen
4555 Raymond Rd.
Jackson, MS 39212

RISK MANAGEMENT DIVISION **Estimate #** 565
Estimate Date 04/26/2022

DESCRIPTION	AMOUNT
REMOVE FURNITURE	350.00
SANITIZE	250.00
FINAL CLEAN UP	2,300.00
Subtotal	2,900.00
8.0%	232.00
TOTAL	\$3,132.00 USD

Office of the City Attorney

455 East Capitol Street
Post Office Box 2779
Jackson, Mississippi 39207-2779
Telephone: (601) 960-1799
Facsimile: (601) 960-1756

OFFICE OF THE CITY ATTORNEY

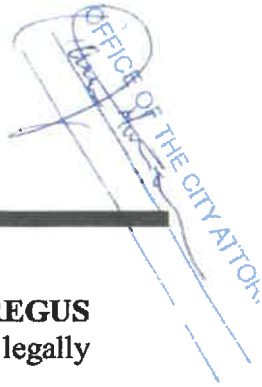

This **ORDER AUTHORIZING PAYMENT OF \$30,000.00 TO THE ESTATE OF REGUS MCCULLEN AS FULL AND COMPLETE SETTLEMENT OF PROPERTY CLAIM** is legally sufficient for placement in NOVUS Agenda.



Cateria Martin, City Attorney

5/14/23

DATE



Carrie Johnson, Senior Deputy City Attorney

5/11/2023

DATE

#38

ORDER AUTHORIZING THE MAYOR TO EXECUTE A CONTRACT WITH KAYLA POWE TO SERVE AS A LEGAL INTERN FOR THE OFFICE OF THE CITY ATTORNEY

WHEREAS, the Office of the City Attorney seeks to hire a legal intern to serve as an assistant in the main office with transactional and litigation attorneys and in the Office of the City Prosecutor; and

WHEREAS, the legal intern will serve in the capacity of a contract worker being paid \$25.00 per hour for approximately six weeks, commencing Tuesday, May 23rd and terminating Friday, June 30, 2023; and

WHEREAS, the Office of the City Attorney received the resume and cover letter from Kayla Powe, a student at the University of Mississippi School of Law; and

WHEREAS, based on the skills and education of Kayla Powe, the Office of the City Attorney and Human Resources Department recommend the City of Jackson employ Kayla Powe as a legal intern for a six week period.

IT IS, THEREFORE, ORDERED that the Mayor is authorized to execute a contract with Kayla Powe to provide assistance to the Office of the City Attorney and Office of the City Prosecutor for a six week period to be paid \$25.00 per hour.

Agenda Item No. 38
May 23, 2023
(C. Martin, Lumumba)

Office of the City Attorney

455 East Capitol Street
Post Office Box 2779
Jackson, Mississippi 39207-2779
Telephone: (601) 960-1799
Facsimile: (601) 960-1756

OFFICE OF THE CITY ATTORNEY

This **ORDER AUTHORIZING THE MAYOR TO EXECUTE A CONTRACT WITH KAYLA POWE TO SERVE AS A LEGAL INTERN FOR THE CITY OF JACKSON ATTORNEY** is legally sufficient for placement in NOVUS Agenda.



Carrie Johnson, Deputy City Attorney

5/17/2023

Date

#39

ORDER REVIEWING AND CONTINUING AUGUST 29, 2022 STATE OF EMERGENCY.

WHEREAS, on August 29, 2022, the Mayor issued a proclamation of emergency as a result of (1) excessive rainfall and extreme flooding, (2) the March 7, 2020 Safe Drinking Water Act (SDWA) Emergency Administrative Order (EAO); (3) the February 2021 system-wide failure due to extreme water conditions that caused pipes to freeze and lose pressure; (4) the July 1, 2021 SDWA Administrative Order of Consent (AOC); (5) the July 29, 2022 Boil Water Notice which existed for more than thirty (30) days; and (6) the August 25, 2022 flooding of the Pearl River, which lead to problems with treating water at the O.B. Curtis Water Plant; and

WHEREAS, Section 33-15-17(d) of the Mississippi Code allows the mayor of a municipality to proclaim a local emergency and authorizes the governing body of a municipality to review and approve or disapprove the need for continuing the local emergency at its first regular meeting following such proclamation or at a special meeting; and

WHEREAS, Section 33-15-5 (h) of the Mississippi Code defines an emergency as “any occurrence, or threat thereof, whether natural, technological, or man-made, in war or in peace, which results or may result in substantial injury or harm to the population or substantial damage to loss of property;” and

WHEREAS, Section 33-15-5 (g) of the Mississippi Code defines a local emergency as “the duly proclaimed existence of conditions of disaster or extreme peril to the safety of person and property within the territorial limits of a...municipality caused by such conditions as...water pollution...or other natural or man-made conditions, which conditions are or are likely to be beyond the control of the services, personnel, equipment and facilities of the political subdivision and require the combined forces of other subdivisions or of the state to combat;” and

WHEREAS, pursuant to Section 33-15-17 (b) of the Mississippi Code, the City “is authorized to exercise the powers vested under [Section 33-15-1, et seq.,] in light of the exigencies of the extreme emergency situation without regard to time-consuming procedures and formalities prescribed by law pertaining to the performance of public work, entering into contracts, the incurring of obligations...and the expenditure of public funds....

NOW, THEREFORE, IT IS ORDERED THAT we the governing body of the City of Jackson, Mississippi, pursuant to the authority vested in the body by Section 33-15-17(d) of the Mississippi Code of 1972, as amended, and in the public interest and for the general welfare of the City of Jackson, do hereby approve of the continued need for a civil emergency for the entire City of Jackson for the reasons set forth in this Order.

Agenda Item No. 39
May 23, 2023
(C. Martin, Lumumba)

#40

**RESOLUTION OF THE CITY COUNCIL OF JACKSON,
MISSISSIPPI HONORING AND RECOGNIZING
*THE ANNUAL JUNETEENTH FREEDOM AND UNITY
CULTURAL CELEBRATION***

WHEREAS, June 19th is a day recognized in the United States of America and across the world as **JUNETEENTH**; and

WHEREAS, Juneteenth has evolved into an African American cultural celebration that originated in the State of Texas because of the confusion and turmoil following the end of the Civil War; those in Texas affected by the Emancipation Proclamation of 1863 did not learn of the 1865 surrender of Robert E. Lee to Ulysses Grant in Virginia; and

WHEREAS, Major General Gordon Granger of the Union Army landed in Galveston, Texas with 1,800 soldiers to take command of the military District of Texas; his first action after landing on June 19, 1865 was to go from his headquarters in the Osterman Building at the corner of Strand and 22nd to read General Order #3 to the people of Galveston: "The people of Texas are informed ... all slaves are free. This involves an absolute equality of personal rights of property between former master and slaves...;" and

WHEREAS, the stunning news began that day as a holiday of celebration, first established in Texas; in 1980, the Texas State Legislature declared **JUNETEENTH**, June 19th, a state holiday; thus began the tradition of prayer services, games, rodeos, dances, special food preparations and historical presentations related to this celebration- - much like the Fourth of July; and

WHEREAS, the City of Jackson, Mississippi celebrates with the world, in honoring the African American cultural celebration of unity and freedom, known throughout the land as **JUNETEENTH**, traditionally celebrated June 19th of each year. Juneteenth became a federal holiday on June 17, 2021 in all 50 states and the District of Columbia.

IT IS HEREBY RESOLVED that the City Council of the City of Jackson, Mississippi, highly honors and recognizes the annual Juneteenth Freedom and Unity Cultural Celebration.

SO RESOLVED, this the 9th day of May, 2023.

Item #: 40

Date: May 23, 2023

By: K. Stokes

#41

ORDER REVIEWING AND CONTINUING STATE OF EMERGENCY.

WHEREAS, on February 18, 2020, the Jackson City Council, pursuant to Section 33-15-17(8)(d) of the Mississippi Code of 1972, as amended, passed an Order Declaring the Need to Continue the State of Emergency that was issued on February 13, 2020 by Chokwe A. Lumumba, Mayor of the City of Jackson, Mississippi; and

WHEREAS, the Jackson City Council, in the February 18, 2020 Order, found that flood waters and wide spread drainage system issues had affected several Jackson creeks, including, but not limited to: Belhaven Creek; Bogue Chitto Creek; Canney Creek; Eubanks Creek; Hanging Moss Creek; Lynch Creek; Purple Creek; Three Mile Creek; Town Creek; Travon Creek; and White Oak Creek; and

WHEREAS, the Jackson City Council, in the February 18, 2020 Order, found that the flood waters and wide spread drainage system issues caused extensive damages to homes, business, public property, and threatened the safety of the citizens and property of the City of Jackson, Mississippi, requiring the exercise of extraordinary measures; and

WHEREAS, the Jackson City Council, in the February 18, 2020 Order, found that all efforts should be taken to protect people and property in consideration of the health, safety, and welfare of the City's residents and the protection of their property within the affected areas; and

WHEREAS, the Jackson City Council, on March 17, 2020; April 14, 2020; May 12, 2020, June 9, 2020, July 7, 2020, August 4, 2020, September 1, 2020, September 29, 2020, October 27, 2020, November 24, 2020, December 22, 2020, January 19, 2021, February 17, 2021, March 30, 2021, April 27, 2021, May 25, 2021, June 22, 2021, July 20, 2021, August 31, 2021, September 28, 2021, October 26, 2021, November 23, 2021, December 21, 2021, January 25, 2022, February 15, 2022, March 29, 2022, April 26, 2022, May 24, 2022, June 21, 2022, July 19, 2022, August 30, 2022, September 27, 2022, October 25, 2022, November 22, 2022, December 20, 2022, January 31, 2023 and February 28, 2023 pursuant to Section 33-15-17(8)(d) of the Mississippi Code of 1972, reviewed the need for and continued the local emergency; and

WHEREAS, pursuant to Section 33-15-17(8)(d) of the Mississippi Code of 1972, as amended, the Jackson City Council has again reviewed the need for continuing the local emergency and determined that the emergency should be continued.

IT IS THEREFORE HEREBY ORDERED that said Order Declaring the Need to Continue the Declared State of Emergency as delineated by the Jackson City Council, remains in full force and effect and shall be reviewed again in thirty (30) days in accordance with Section 33-15-17(8)(d) of the Mississippi Code of 1972, as amended

Agenda Item No. 41
May 23, 2023
(Jackson City Council)

