

# City of Kettering

3600 Shroyer Road  
Kettering, Ohio 45429  
Montgomery County  
937-296-2436

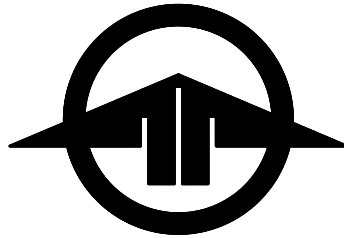

## **STANDARD CONSTRUCTION DRAWINGS**

**EFFECTIVE JANUARY 14, 2019**

# TABLE OF CONTENTS

ITEM #	TITLE	SHEET #
	ROADWAY & TRENCH RESTORATION	1
	ROADWAY & TRENCH RESTORATION NOTES	2
	TYPICAL ROADWAY SECTION	3
	ASPHALT OVERLAY GUTTER FINISH STANDARD	4
K-255	CONCRETE PAVEMENT REPAIR	5
K-255	CONCRETE PAVEMENT REPAIR & NOTES	6
K-608A	SIDEWALK DETAIL	7
K-608A	ADA RAMP NOTES	8
K-608A	ADA RAMP SCHEMATIC	9-15
K-608A	UTILITY PULL BOX IN SIDEWALK	16
K-608B	RESIDENTIAL DRIVE APPROACH	17
K-608B	COMMERCIAL DRIVE APPROACH	18
K-608B	ALLEY APPROACH	19
K-608B	DRIVE APPROACH, WALK AT BACK OF CURB	20
K-608B	DRIVE APPROACH NOTES	21
K-609	CURB AND GUTTER	22-23
K-609	CURB AND GUTTER NOTES	24
K-609	CURB AND GUTTER REPAIR, CONCRETE STREETS	25
K-609	MEDIAN NOSE CONCRETE	26
K-609	MEDIAN NOSE GRASS	27
K-611	CATCH BASIN TYPE A	28
K-611	CATCH BASIN TYPE 3	29
K-611	CATCH BASIN TYPE 3A	30
K-611	YARD INLET	31
K-611	12" SLOTTED DRAIN	32
K-901	FIRE HYDRANT LOCATION	33
K-911	GRAVITY RETAINING WALL	34

**Pages/items marked in RED were substantially revised in 2019.**

THESE STANDARDS ARE REQUIRED FOR ALL CITY OF KETTERING PROJECTS AND PRIVATE DEVELOPMENT WITHIN THE CITY OF KETTERING RIGHT-OF-WAY UNLESS OTHERWISE AUTHORIZED BY THE CITY ENGINEER.

INTERPRETATION OF ALL DATA ON THESE DRAWINGS AND ANY QUESTIONS SHALL BE DECIDED BY THE CITY OF KETTERING.

STANDARD DRAWING			TABLE OF CONTENTS	APPROVAL	
DATE	REVISION	BY		 CITY ENGINEER	
			 <b>City of Kettering</b>	JANUARY 2019	

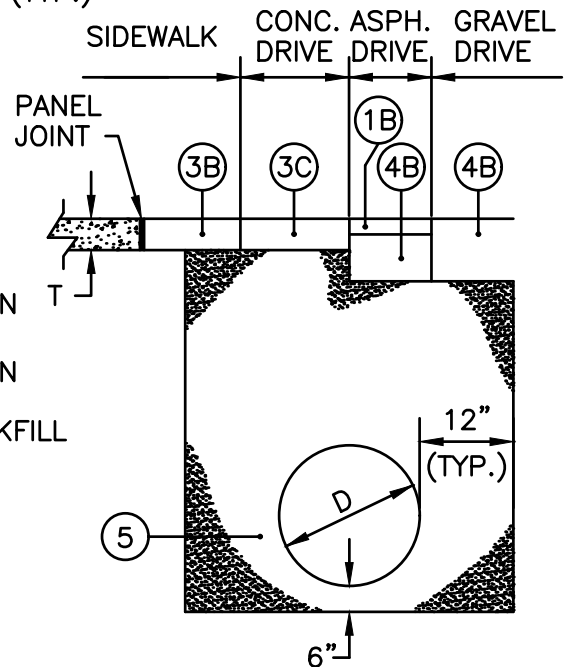
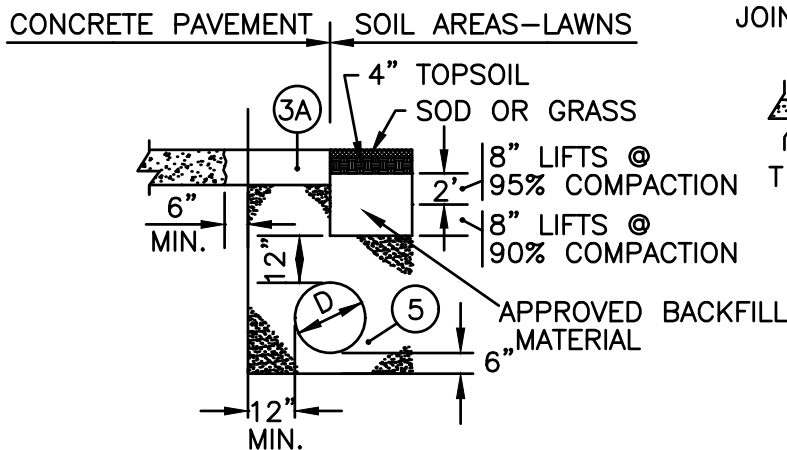
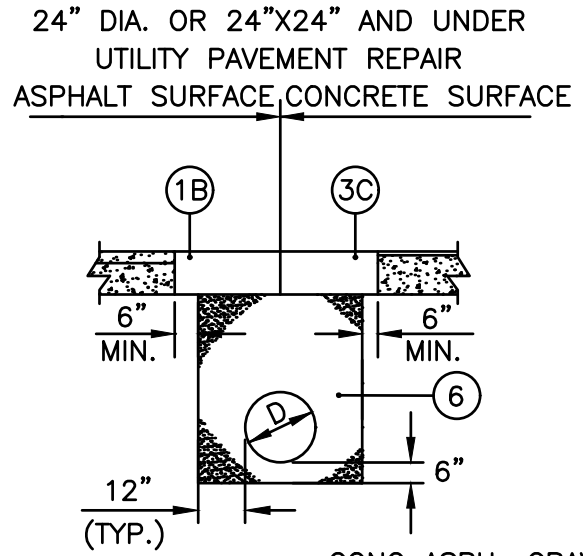
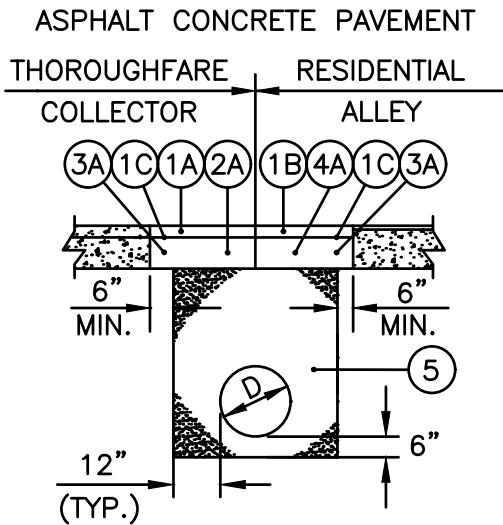

**LEGEND**

- ①A 3" ODOT-441 ASPHALT CONCRETE (TWO 1.5" LIFTS)
- ①B MATCH EXISTING, WITH A MINIMUM OF 2" ODOT-441 ASPHALT CONCRETE (1" MAX LIFTS)
- ①C TACK COAT (0.1 GAL/S.Y.)
- ②A 6"-8" K-301 ASPHALT CONCRETE BASE
- ③A 9" PORTLAND CEMENT CONCRETE (THOROUGHFARES/COLLECTORS) DOWELS PER K-255, SHEETS 5 & 6 6" MIN. PORTLAND CEMENT CONCRETE, K-452 (RESIDENTIAL)
- (SEE ROADWAY RESTORATION & TRENCH NOTES, SHEET 2)
- ③B 4" PORTLAND CEMENT CONCRETE, K-608 6" PORTLAND CEMENT CONCRETE, K-608 ON DRIVE APPROACH AREA
- ③C MATCH EXISTING, WITH A MINIMUM OF 6" PORTLAND CEMENT CONCRETE, K-608
- ④A 5" MIN. K-301 ASPHALT CONCRETE BASE (2.5" MAX LIFTS)
- ④B 6" K-304 AGGREGATE BASE
- ⑤ APPROVED GRANULAR BACKFILL, OR LOW STRENGTH MORTAR (AS DIRECTED BY THE ENGINEER)
- ⑥ LOW STRENGTH MORTAR 100

STANDARD DRAWING		
DATE	REVISION	BY

ROADWAY & TRENCH RESTORATION

City of Kettering

APPROVAL

CITY ENGINEER

---

JANUARY 2019      SHEET 1

# ROADWAY AND TRENCH RESTORATION

## NOTES

1. ALL RESTORATION TO BE OF THE SAME OR GREATER THICKNESS AS EXISTING, AS SPECIFIED IN THESE STANDARDS AND/OR THE CONSTRUCTION AND MATERIAL SPECIFICATIONS OF THE CITY OF KETTERING.
2. WHEN DIRECTED BY THE ENGINEER, LOW STRENGTH MORTAR BACKFILL (LSM-100, PER ODOT SPEC 613) SHALL BE USED FOR BACKFILL.
3. DURING PERIODS OF INCLEMENT WEATHER, A TEMPORARY REPAIR MAY BE PERMITTED. APPROVED GRANULAR BACKFILL OR FAST-SET LOW STRENGTH MORTAR, LSM-100, (AS DIRECTED BY THE ENGINEER) MAY BE USED AS BACKFILL AND SHALL BE PLACED TO MATCH THE BOTTOM ELEVATION OF THE EXISTING PAVEMENT SECTION SURROUNDING THE UTILITY CUT. TEMPORARY CONCRETE AND OR ASPHALT MAY THEN BE PLACED AND LEVELED TO BE FLUSH WITH THE EXISTING PAVEMENT SURFACE ELEVATION. THE CONTRACTOR SHALL MAKE PROVISIONS TO PROTECT THE CONCRETE FROM FREEZING UNTIL IT HAS PROPERLY CURED. WHEN CONDITIONS ALLOW, THE TEMPORARY CONCRETE AND/OR ASPHALT SHALL BE REMOVED AND REPLACED WITH A PERMANENT REPAIR, AS SPECIFIED ON THE PREVIOUS SHEET.
4. SAW CUT ALL EDGES SQUARE AND EVEN. IN CONCRETE, SAW A MINIMUM OF 2" OR T/3, WHICHEVER IS GREATER.
5. SEAL ASPHALT EDGES WITH LIQUID A.C.
6. ON ALL THOROUGHFARES, HIGH EARLY STRENGTH (FAST SET) CONCRETE SHALL BE USED FOR CONCRETE PAVEMENT RESTORATION.
7. ALL CONCRETE PAVEMENT REPAIRS AND ALL ADJACENT REMAINING PANELS SHALL HAVE A MINIMUM OF 5' DIMENSION IN ANY DIRECTION. PANEL REPAIRS SHALL BE EXTENDED TO THE NEAREST EXISTING JOINT IF THE REPAIR AREA IS WITHIN 5' OF AN EXISTING JOINT, UNLESS OTHERWISE APPROVED BY THE ENGINEER.
8. THE SPECIFIED RESTORATION THICKNESSES ARE CONSIDERED AS MINIMUMS. WHERE EXISTING MATERIALS ARE THICKER, THE RESTORATION MATERIAL SHALL MATCH THE EXISTING THICKNESS.
9. CONCRETE SHALL MEET SPEC K-499 AND SHALL BE SUPPLIED THROUGH A CITY OF KETTERING APPROVED READY MIX SUPPLIER.
10. FOR REPAIRS TO CONCRETE PAVEMENT, REFER TO CONCRETE PAVEMENT REPAIR STANDARD DRAWINGS AND CONSTRUCTION MATERIAL SPECIFICATIONS FOR REPAIR STANDARDS.
11. A RIGHT-OF-WAY CONSTRUCTION PERMIT IS REQUIRED FOR ALL EXCAVATION WITHIN THE CITY RIGHT-OF-WAY AND CITY EASEMENT.
12. COMPACTION OF ASPHALT LIFTS PER ENGINEER'S DIRECTION.

STANDARD DRAWING			ROADWAY & TRENCH RESTORATION NOTES		APPROVAL	
DATE	REVISION	BY			 CITY ENGINEER	
			 <b>City of Kettering</b>		JANUARY 2019	

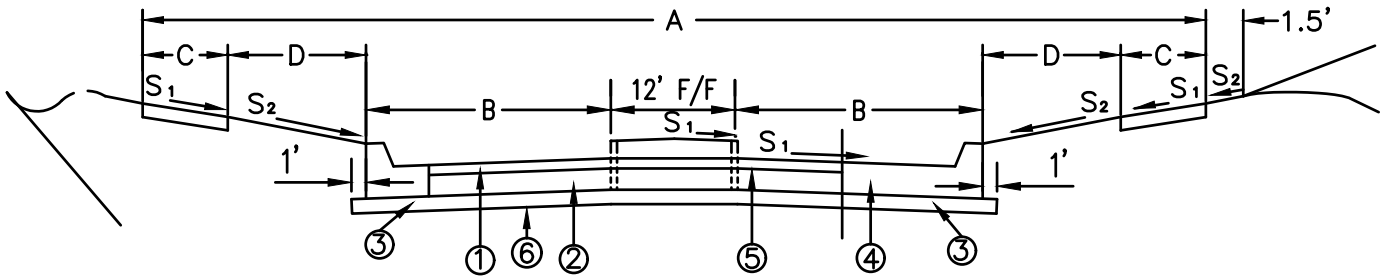

SECTION I

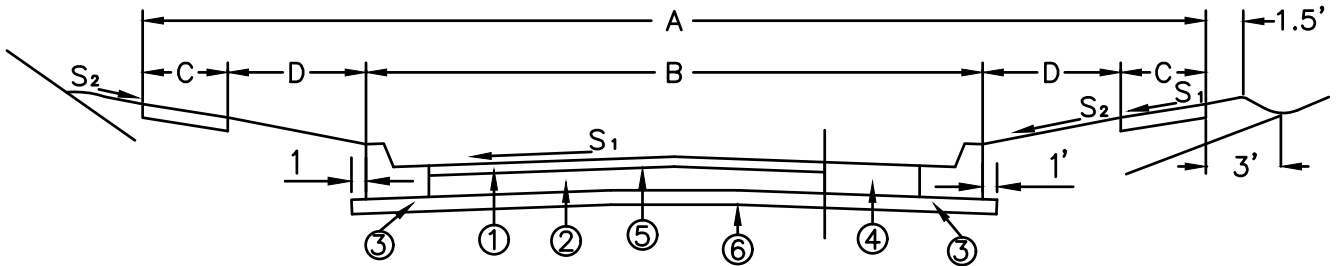

**SLOPES**

S<sub>1</sub> = 1/4" PER FOOT  
 S<sub>2</sub> = 1/2" PER FOOT

SECTIONS II & III

SECTION	WIDTH IN FEET					DESIGN THICKNESS IN INCHES				
						ASPHALT			CONCRETE	
						K-441/442	K-301	K-304	K-452	K-304
	A	B	C	D	R/W	①	②	③	④	⑤
I. ARTERIAL	89	25.5	5	8	90	2.5	5	9	9	6
II. COLLECTOR	67	41	5	8	70	2.5	5	8	9	6
III. RESIDENTIAL/ALLEY	50	29	5	5.5	50	2.5	5	6	6	6

**LEGEND**

- ① K-441/442 ASPHALT CONCRETE  
1.0" TYPE 1 INTERMEDIATE COURSE  
1.5" TYPE 1 SURFACE COURSE
- ④ K-452 CONCRETE PAVEMENT
- ② K-301 ASPHALT CONCRETE BASE
- ⑤ ODOT-407 TACK COAT
- ③ K-304 AGGREGATE BASE
- ⑥ K-204 SUBGRADE COMPACTION

**NOTES**

1. ANY VARIANCES OR MODIFICATIONS TO THE TYPICAL ROADWAY SECTIONS SHALL BE REVIEWED BY THE ENGINEERING DEPARTMENT. VARIANCES AND ALTERNATE PAVEMENT DESIGNS ARE SUBJECT TO PLANNING COMMISSION APPROVAL, WHEN APPLICABLE.
2. SOIL CONDITIONS AND/OR SOIL TESTING MAY REQUIRE MODIFICATIONS IN PAVEMENT THICKNESS AND DESIGN. USE OF GEOTEXTILE FABRIC AND/OR GEOGRIDS SHALL BE USED AT THE DISCRETION OF THE CITY ENGINEER. UNDERDRAINS SHALL BE USED AS REQUIRED BY SUBSURFACE CONDITIONS AND AS DIRECTED BY THE CITY ENGINEER.
3. ALL CUT AND FILL EMBANKMENT SLOPES SHALL BE NO STEEPER THAN 4:1 UNLESS APPROVED BY THE CITY ENGINEER. USE 3' ROUNDINGS AT ALL EARTHWORK GRADE CHANGES.

STANDARD DRAWING			TYPICAL ROADWAY SECTION		APPROVAL  CITY ENGINEER
DATE	REVISION	BY	<b>City of Kettering</b>		JANUARY 2019
					SHEET <b>3</b>

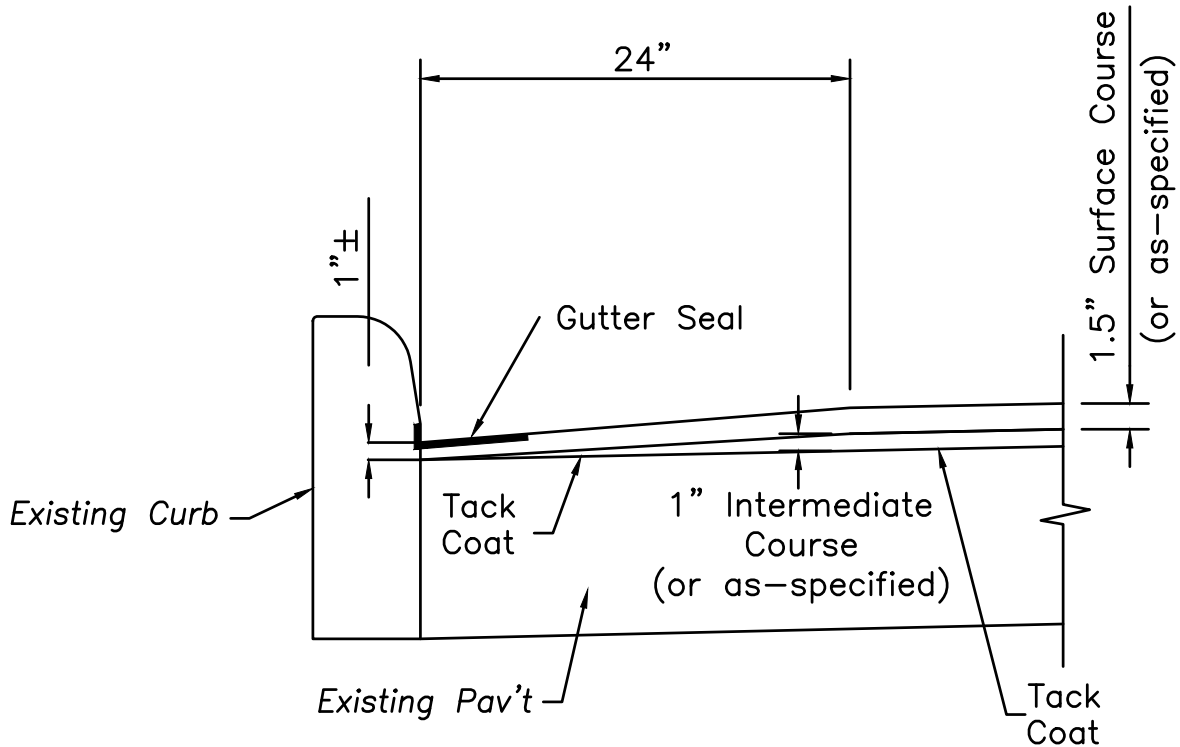

**NOTES**

1. CONTRACTOR SHALL MILL THE EXISTING ASPHALT AGAINST THE CURB AS SPECIFIED, THEN FINISH AS SHOWN IN THE DETAIL ABOVE.
2. SPECIAL CARE SHALL BE TAKEN DURING CONSTRUCTION TO OBTAIN MAXIMUM COMPACTION OF ASPHALT IN GUTTERS AND IN FRONT OF CURBS, WITHOUT DAMAGING EXISTING CURB.
3. ALL BUTT JOINTS AND CURB EDGES SHALL BE SEALED WITH LIQUID AC.

STANDARD DRAWING		
DATE	REVISION	BY

**ASPHALT OVERLAY  
GUTTER FINISH STANDARD**

**City of Kettering**

APPROVAL  
  
 CITY ENGINEER

---

JANUARY 2019      SHEET  
    **4**

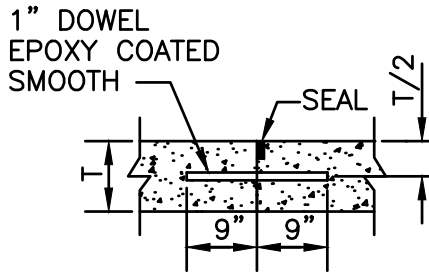

① CONSTRUCTION JOINT  
T = 9"

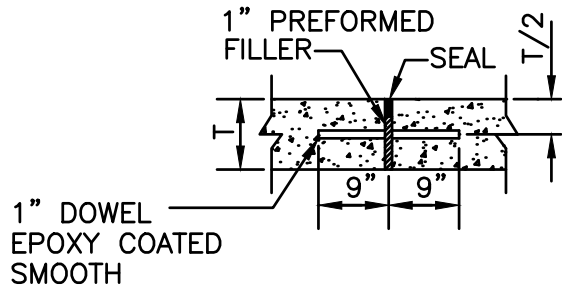

② EXPANSION JOINT  
T = 9"

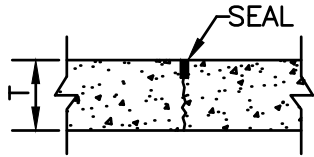

③ CONSTRUCTION JOINT  
T = 6" & 9"

TRANSVERSE JOINTS

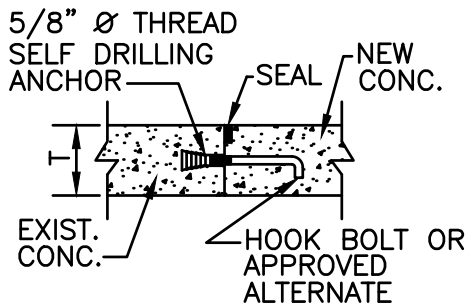

④ EXPANSION BUTT JOINT  
T = 9"

LONGITUDINAL JOINTS

STANDARD DRAWING		
DATE	REVISION	BY

K-255  
CONCRETE PAV'T REPAIR

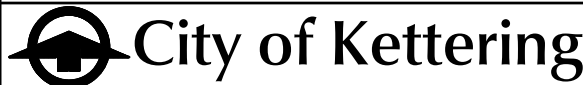



APPROVAL

*Steve R...*  
CITY ENGINEER

JANUARY 2019

SHEET  
5

1. ALL DOWEL BARS AND HOOKS SHALL BE EPOXY COATED SMOOTH AND 1" IN DIAMETER.
2. DOWEL BARS SHALL BE SPACED AT 18"-24" CENTERS (NOT TO EXCEED 24") BEGINNING 6" FROM THE EDGE OF PAVEMENT.
3. DOWELS SHALL BE SECURED INTO EXISTING PAVEMENT WITH NON-SHRINK GROUT OR EPOXY CEMENT.
4. SELF-DRILLING ANCHORS AND HOOK BOLTS SHALL COMPLY WITH ODOT SPECIFICATIONS AND SHALL BE SPACED AT 30" CENTERS OR AS DIRECTED BY THE ENGINEER.
5. JOINT SEALER MATERIAL SHALL MEET REQUIREMENTS OF ODOT 705.04 OR 705.11.
6. AT STREET INTERSECTIONS, THICKNESS AND TYPE OF PAVEMENT OF MAJOR STREET TO BE CONSTRUCTED TO THE POINT OF CURVATURE OF THE CURB RETURN ON THE MINOR STREET.
7. CONCRETE SHALL MEET KETTERING SPECS (K-499) AND SHALL ONLY BE SUPPLIED THROUGH A CITY OF KETTERING APPROVED READY MIX SUPPLIER.

STANDARD DRAWING			K-255 CONCRETE PAV'T REPAIR & NOTES		APPROVAL  CITY ENGINEER	
DATE	REVISION	BY	 <b>City of Kettering</b>			JANUARY 2019
						SHEET <b>6</b>



## SIDEWALK DETAILS

JOINTS 1" DEEP EVERY 15' FINISHED WITH A RADIUS OF 3/8"

JOINT SPACING = 5'

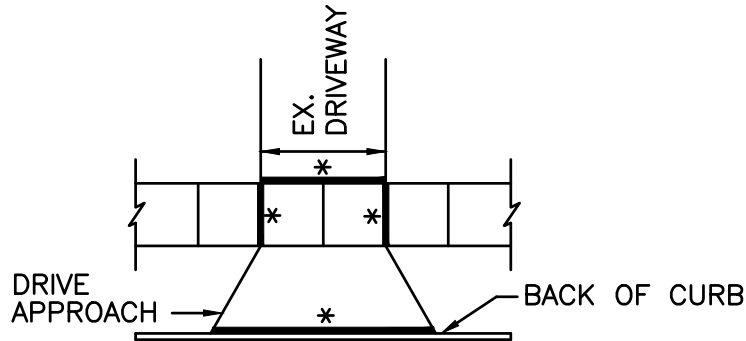
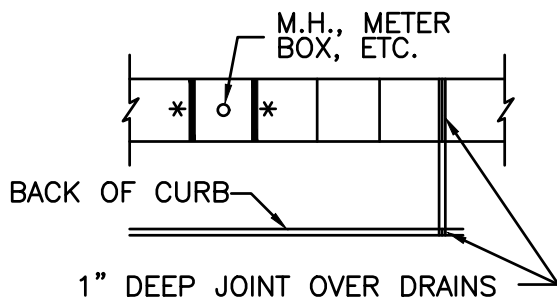
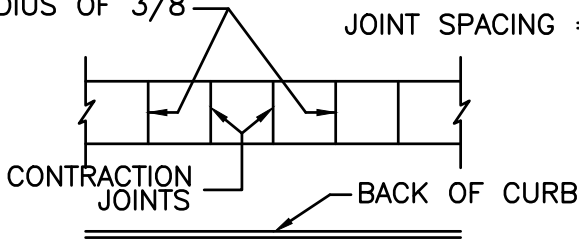

\* 1/2" EXPANSION JOINT MATERIAL

### WALK ADJACENT TO CURB DETAIL

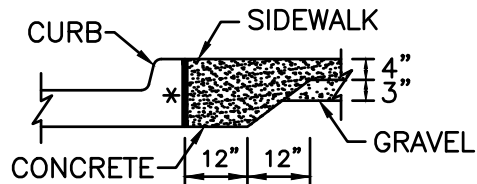

(TO BE USED WHERE CURB & SIDEWALK ARE ADJOINING)

### NOTES

1. SIDEWALK SHALL BE A MINIMUM OF 5' WIDE OR MATCH EXISTING ON 50' R/W STREETS, OR WIDTH AS DIRECTED BY THE ENGINEER.
2. SIDEWALK SHALL BE 4" THICK, EXCEPT WHEN THROUGH DRIVEWAYS (6" THICK), AND WHEN ADJACENT TO CURB (VARIABLE THICKNESS AS SHOWN ABOVE).
3. EXPANSION JOINT MATERIAL OR APPROVED EQUAL, SHALL BE PLACED AS SHOWN. A MAXIMUM SPACING OF 50' FOR NEW CONSTRUCTION, BOTH SIDES OF EXISTING CONCRETE FOR REPLACEMENT SECTIONS EQUAL TO OR GREATER THEN 15' OR ONE SIDE OF EXISTING CONCRETE FOR REPLACEMENT SECTION LESS THEN 15'.
4. THE SUBGRADE BENEATH THE PROPOSED SIDEWALK IS TO BE COMPACTED TO THE MAXIMUM EXTENT PRACTICAL. A MINIMUM OF 3" OF GRAVEL (OR CRUSHED AGGREGATE) BASE SHALL BE PLACED UNDER THE SIDEWALK IF DETERMINED NECESSARY BY THE ENGINEER.
5. CONCRETE SHALL MEET SPECS K-499 AND SHALL ONLY BE SUPPLIED THROUGH A CITY OF KETTERING APPROVED READY MIX SUPPLIER.
6. SIDEWALKS SHALL BE SLOPED BETWEEN 1 AND 2% TOWARD THE STREET, OR AS APPROVED BY THE ENGINEER.
7. ANY TOOL MARKS LEFT BY EDGING SHALL BE ELIMINATED BY TEXTURING THE SURFACE. THE FINAL SURFACE SHALL BE BROOM FINISHED. RETOOLED JOINTS SHALL NOT BE CONSTRUCTED UNLESS APPROVED BY THE ENGINEER.

STANDARD DRAWING		
DATE	REVISION	BY

K-608A  
SIDEWALK DETAIL

City of Kettering

APPROVAL

CITY ENGINEER

---

JANUARY 2019

SHEET  
**7**



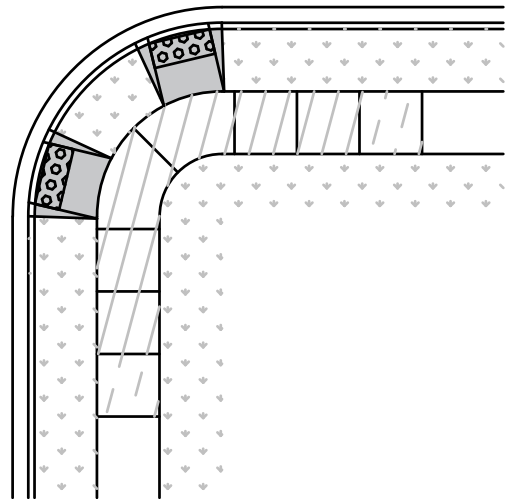
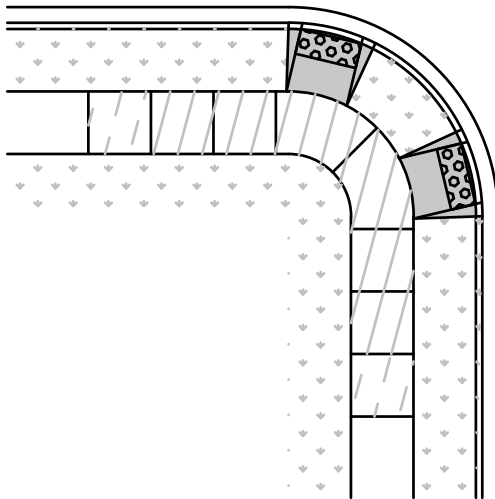
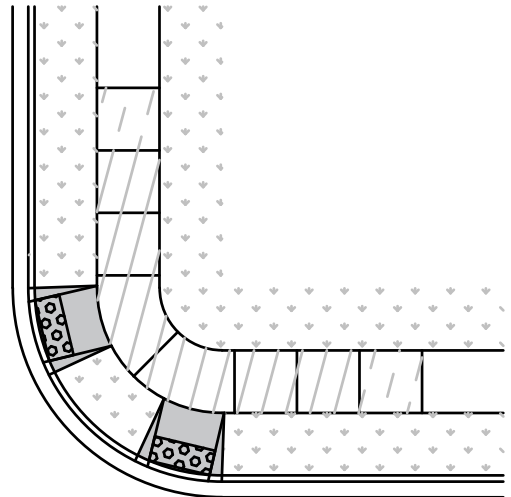
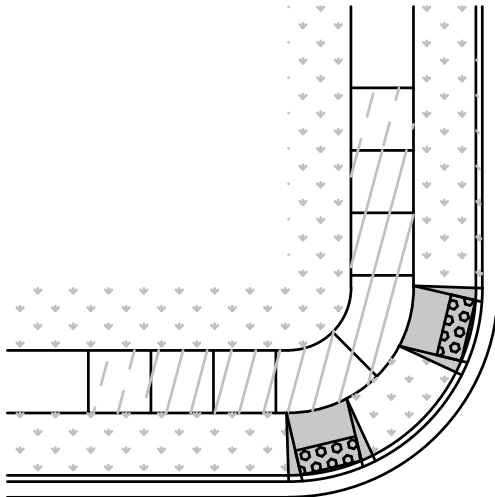

GENERAL NOTES

1. THESE ADA RAMP SCHEMATICS ARE INTENDED TO SUPPLEMENT ODOT STANDARD DRAWING BP-7.1. THESE SCHEMATICS USE ODOT'S RAMP NOMENCLATURE, BUT HAVE ADDED A PREFIX OF K (EX. K-C1) TO INDICATE MODIFICATION TO THE CONTEXT OF RAMPS IN KETTERING.
2. PRIOR TO CONSTRUCTION, THE ENGINEER WILL INSPECT THE CURB RAMP(S) TO EVALUATE COMPLIANCE, AND WHEN NECESSARY, DETERMINE THE SCOPE OF CONSTRUCTION FOR REPLACEMENT. THIS WILL GENERALLY INCLUDE FIELD-MARKING THE PLAN VIEW OF THE PROPOSED RAMP ON THE GROUND, IDENTIFYING THE WIDTH AND ORIENTATION OF THE DETECTABLE WARNING, IDENTIFYING LENGTHS OF THE RAMP AND TURNING SPACE, AND IDENTIFYING THE EXTENT OF SIDEWALK (CHASE LENGTH) TO BE REMOVED TO ACHIEVE SLOPE COMPLIANCE.
3. ONCE CONSTRUCTED, THE ENGINEER INSPECTOR WILL INSPECT THE CURB RAMP TO EVALUATE COMPLIANCE, AND WHEN NECESSARY, REQUIRE RECONSTRUCTION.
4. THOUGH THE ADA REQUIRES A MINIMUM OF 15' CHASE LENGTH TO ACHIEVE SLOPES, ADDITIONAL LENGTH MAY BE NECESSARY TO BEST FIT INTO THAT SPECIFIC CONTEXT.
5. IT IS PREFERABLE TO USE TWO ADA RAMPS PER CORNER (REFERENCE SHEET 9). OTHER SCHEMATICS SHOW THE DESIGN WHEN ONLY ONE RAMP IS USED.
6. THE WIDTH OF A DETECTABLE WARNING IS PRIMARILY DEPENDENT ON THE EFFECTIVE WIDTH OF THE PEDESTRIAN PATH TRAVELING FROM THE SIDEWALK TO THE CROSSWALK. WHEN DESIGNING/CONSTRUCTING RAMPS, DESIGNERS/CONTRACTORS ARE TO REQUEST THE ENGINEER TO SPECIFY THE WIDTH OF THE DETECTABLE WARNING. THE WIDTH OF THE DETECTABLE WARNING WILL TYPICALLY BE THE SAME WIDTH AS THE SIDEWALK. THREE COMMON EXCEPTIONS EXIST:
  - 1) THE WIDTH OF THE DETECTABLE WARNING ON A K-C2, K-C2 (MODIFIED), OR K-C1 RAMP IS DETERMINED BY THE EFFECTIVE TRAVELING WIDTH FOR A PEDESTRIAN TRAVELING FROM THE SIDEWALK TO THE CROSSWALK, THUS IT IS USUALLY 1-2 FEET WIDER THAN THE SIDEWALK BECAUSE IT IS ON AN ANGLE;
  - 2) THE WIDTH OF DETECTABLE WARNING ON A K-B3 RAMP WHEN PLACED PARALLEL TO THE CURB IS NO LESS THAN THE PROJECTED WIDTH OF THE SIDEWALK; AND
  - 3) THE WIDTH OF THE DETECTABLE WARNING ON A K-B2 RAMP IS DETERMINED BY THE PEDESTRIAN CONTEXT (WIDTH OF SIDEWALK AND PEDESTRIAN USAGE).
7. SIDEWALK TRANSITION PANELS ARE USED WHEN THE EXISTING SIDEWALK DOES NOT MEET CROSS-SLOPE REQUIREMENTS. THE CROSS-SLOPE CORRECTION FOR EACH 1/2% IS CORRECTED OVER ONE FOOT. FOR EXAMPLE, IF THE EXISTING SIDEWALK CROSS-SLOPE IS 4.5% AND THE DESIRED CROSS-SLOPE IS 1.5%, THE TRANSITION WOULD BE  $2 \times (4.5 - 1.5) = 6$  LINEAL FEET OF SIDEWALK (AND THEN ROUNDING UP TO THE NEAREST JOINT).
8. IT IS IMPORTANT TO ACHIEVE PROPER SLOPES FOR ACCESS, AND ALSO PROPER DRAINAGE TO AVOID ICING AND SEDIMENTATION. WHEN SPECIFIED SLOPES CANNOT BE REASONABLY MET, THE ENGINEER WILL PROVIDE GUIDANCE.
9. CURB AT THE BACK OF A SIDEWALK OR A RAMP IS DISCOURAGED, BUT CAN BE USED WITH THE PERMISSION OF THE ENGINEER. WHEN USED, THE PAY ITEM FOR THE CURB AT THE BACK OF THE SIDEWALK OR RAMP IS NOT CURB, BUT WHAT IS ADJACENT TO AND POSSIBLY INTEGRAL WITH (SIDEWALK OR CURB RAMP). THE PAY QUANTITY IS AN AREA MEASUREMENT BASED ON THE TOTAL SQUARE FOOTAGE OF THE EXPOSED FRONT FACE AND TOP.
10. THE SUBGRADE BENEATH THE PROPOSED CURB RAMP IS TO BE COMPACTED TO THE MAXIMUM EXTENT PRACTICAL. A MINIMUM OF 3" OF GRAVEL (OR CRUSHED AGGREGATE) BASE SHALL BE PLACED UNDER THE CURB RAMP IF DETERMINED NECESSARY BY THE ENGINEER.

STANDARD DRAWING			K-608A ADA RAMP NOTES		APPROVAL  CITY ENGINEER	
DATE	REVISION	BY	 <b>City of Kettering</b>		JANUARY 2019	SHEET <b>8</b>





**LEGEND**

-  DETECTABLE WARNING
-  6" CURB RAMP
-  SIDEWALK
-  TRANSITION PANEL  
(IF NECESSARY)

**NOTE:**



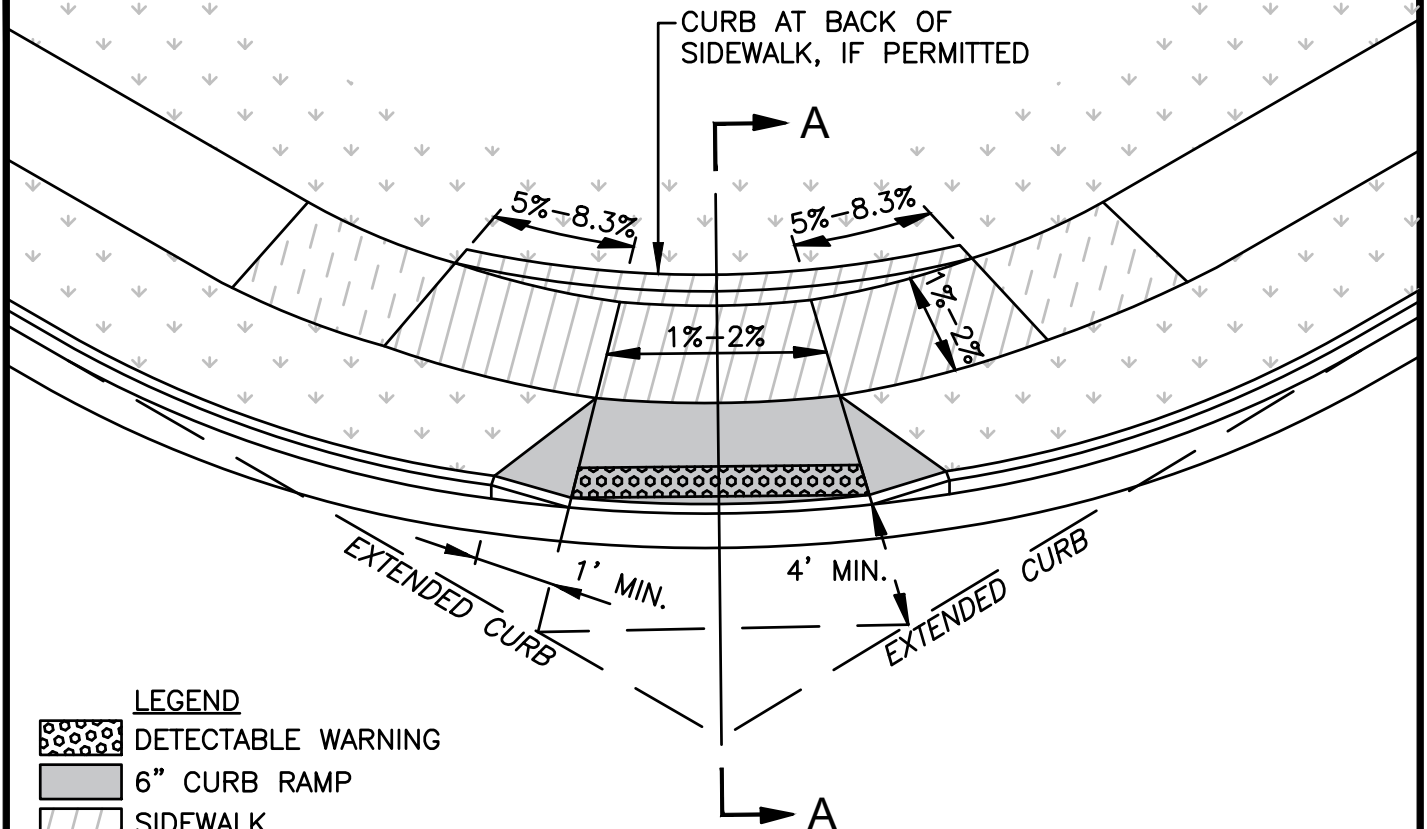

1. PREFERABLE TO USE TWO ADA RAMPS PER CORNER. OTHER SCHEMATICS SHOW THE DESIGN WHEN ONLY ONE RAMP (DIAGONAL) IS USED.

STANDARD DRAWING			K-608A ADA RAMP SCHEMATIC		APPROVAL  CITY ENGINEER
DATE	REVISION	BY	 <b>City of Kettering</b>		JANUARY 2019
					SHEET <b>9</b>

K-C2



**LEGEND**

-  DETECTABLE WARNING
-  6" CURB RAMP
-  SIDEWALK
-  TRANSITION PANEL (IF NECESSARY)

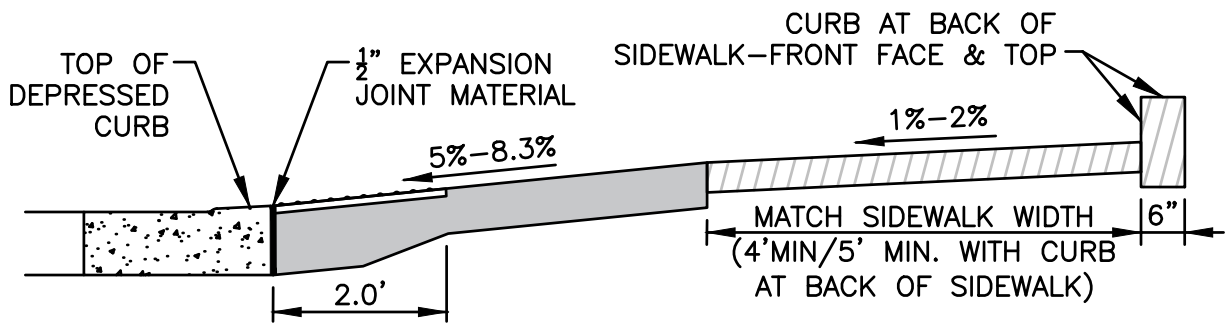

**SECTION A-A**





**NOTES:**

1. TYPICALLY USED AT TWO STREETS OF SIMILAR CLASSIFICATION (LOCAL–LOCAL OR THOROUGHFARE–THOROUGHFARE).
2. REFER TO SHEET 8 FOR ADA RAMP NOTES.
3. REFER TO SHEET 23 FOR DEPRESSED CURB AT ADA RAMP.
4. EXPOSED CURB AT BACK OF SIDEWALK REVEAL MUST EQUAL BURIED DEPTH; 12" MAXIMUM REVEAL.

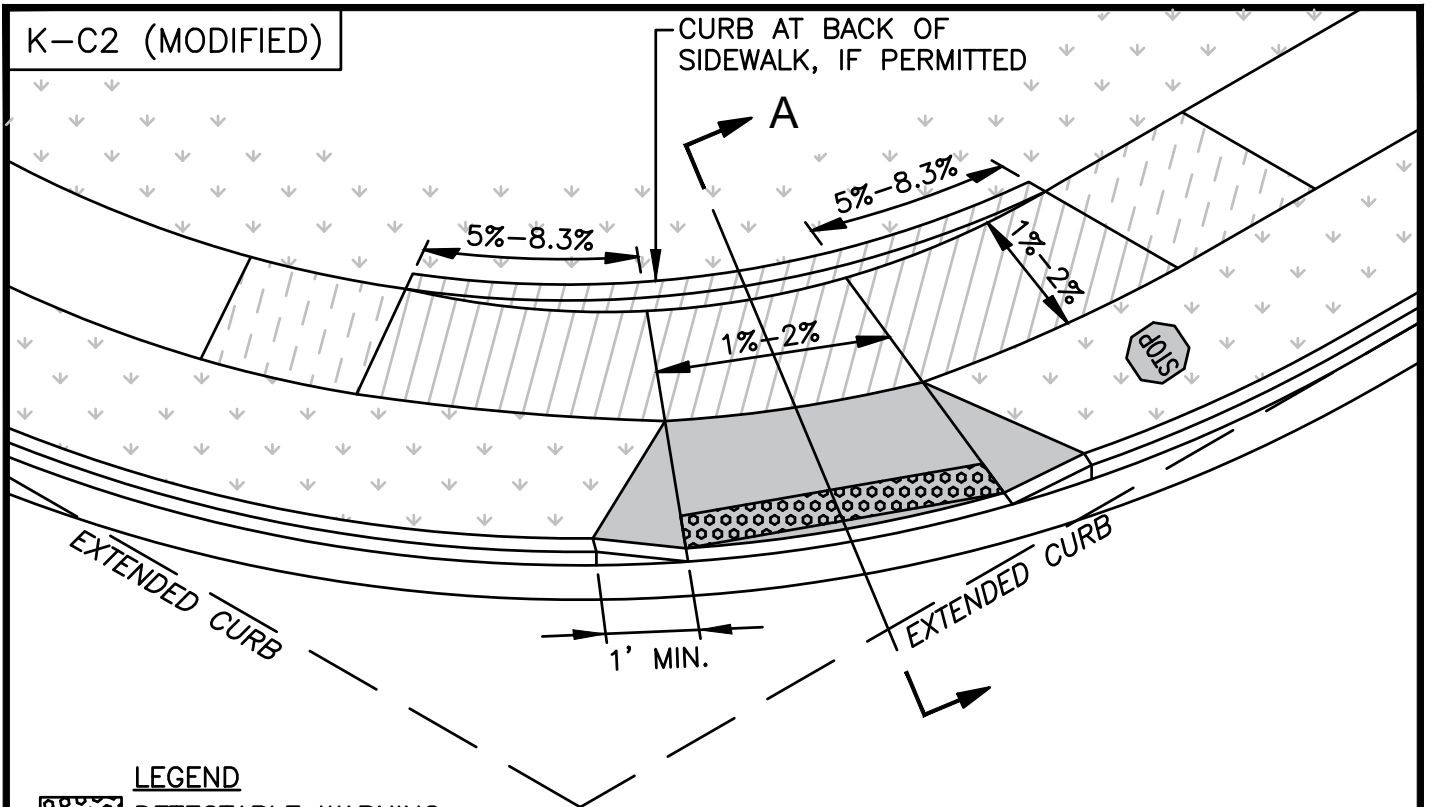
STANDARD DRAWING			K-608A ADA RAMP SCHEMATIC		APPROVAL	
DATE	REVISION	BY				
			 <b>City of Kettering</b>		JANUARY 2019	SHEET <b>10</b>

K-C2 (MODIFIED)



- LEGEND**
-  DETECTABLE WARNING
  -  6" CURB RAMP
  -  SIDEWALK
  -  TRANSITION PANEL (IF NECESSARY)

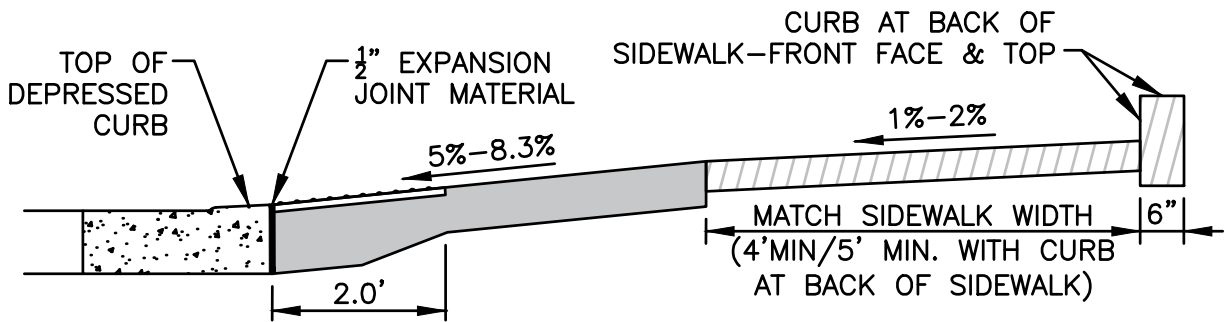

**SECTION A-A**

**NOTES:**

1. TYPICALLY USED WHERE ADA RAMP FAVORS THE STOPPED APPROACH TO KEEP PEDESTRIANS AWAY FROM THROUGH TRAFFIC.
2. REFER TO SHEET 8 FOR ADA RAMP NOTES.
3. REFER TO SHEET 23 FOR DEPRESSED CURB AT ADA RAMP.
4. EXPOSED CURB AT BACK OF SIDEWALK REVEAL MUST EQUAL BURIED DEPTH; 12" MAXIMUM REVEAL.

STANDARD DRAWING		
DATE	REVISION	BY

K-608A  
ADA RAMP SCHEMATIC

 **City of Kettering**

APPROVAL  
  
CITY ENGINEER

JANUARY 2019

SHEET  
**11**

K-C2 (SIMILAR TO A2)

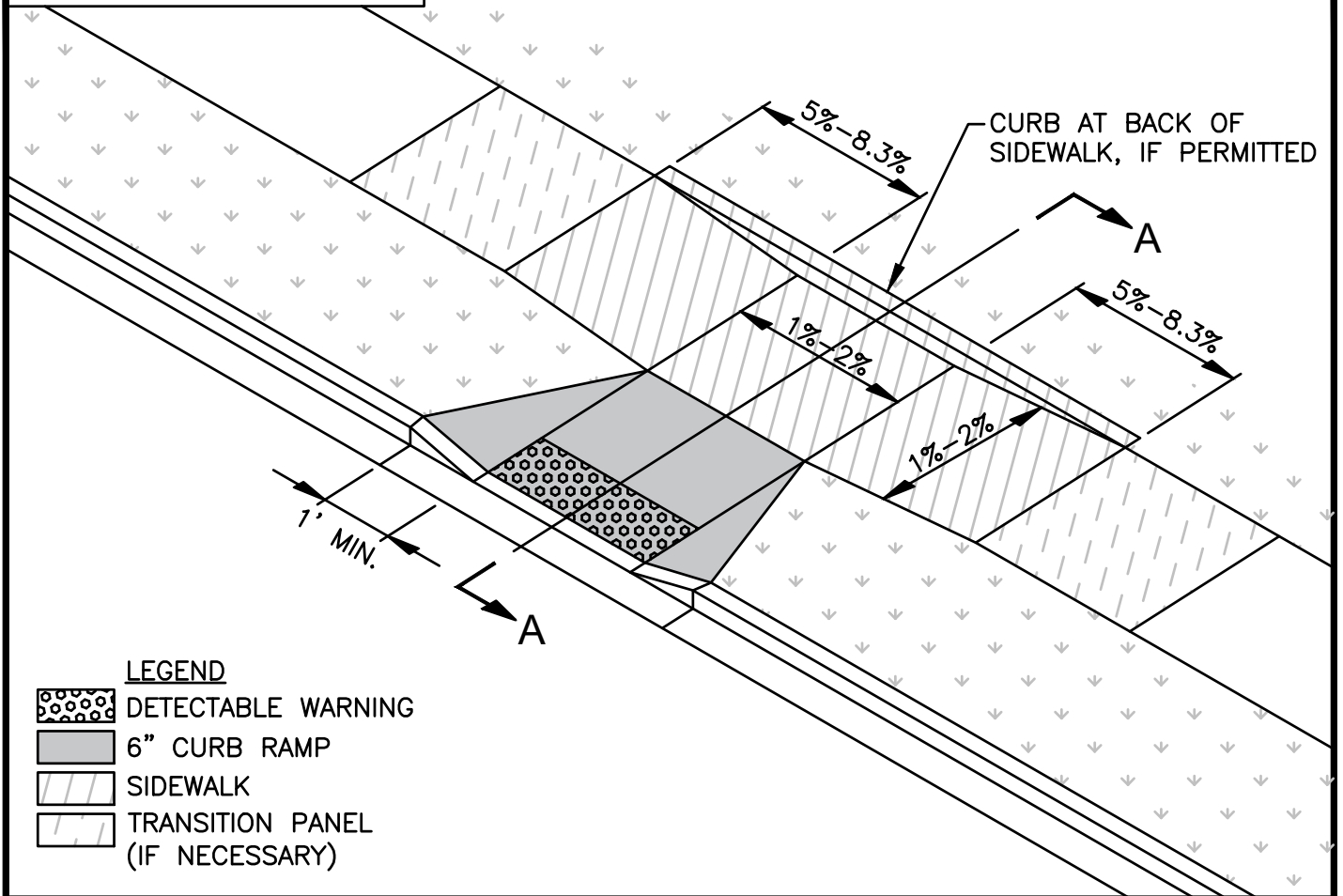

- LEGEND**
- DETECTABLE WARNING
  - 6" CURB RAMP
  - SIDEWALK
  - TRANSITION PANEL (IF NECESSARY)

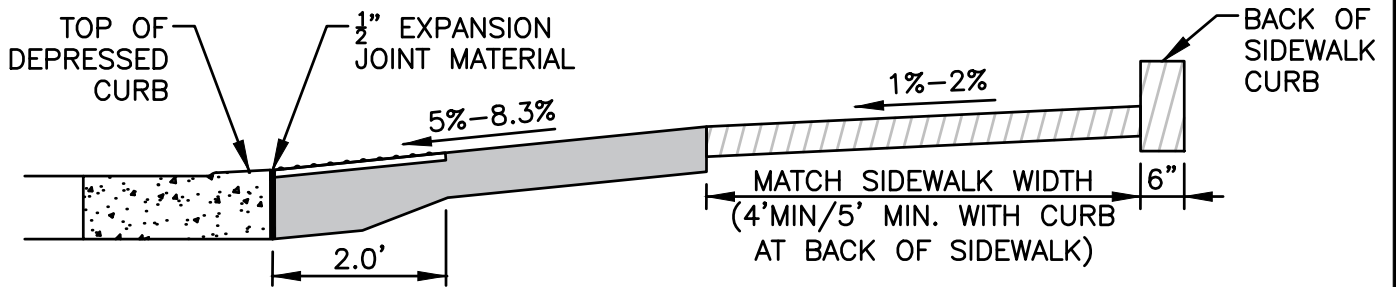

**SECTION A-A**

**NOTES:**

1. TYPICALLY USED WHERE TWO RAMPS EXIST AT ONE CORNER, OR AT MID-BLOCK CROSSWALKS.
2. REFER TO SHEET 8 FOR ADA RAMP NOTES.
3. REFER TO SHEET 23 FOR DEPRESSED CURB AT ADA RAMP.
4. EXPOSED CURB AT BACK OF SIDEWALK REVEAL MUST EQUAL BURIED DEPTH; 12" MAXIMUM REVEAL.

STANDARD DRAWING		
DATE	REVISION	BY

K-608A  
ADA RAMP SCHEMATIC

**City of Kettering**

APPROVAL  
  
CITY ENGINEER

JANUARY 2019

SHEET  
**12**



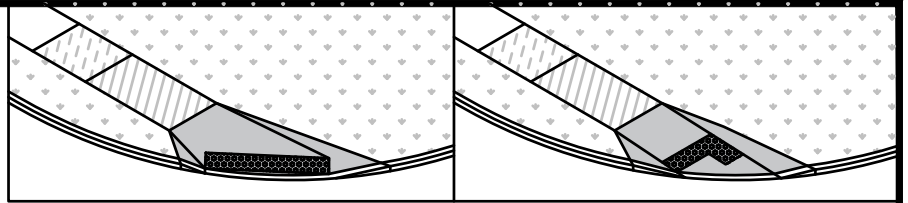

K-B3

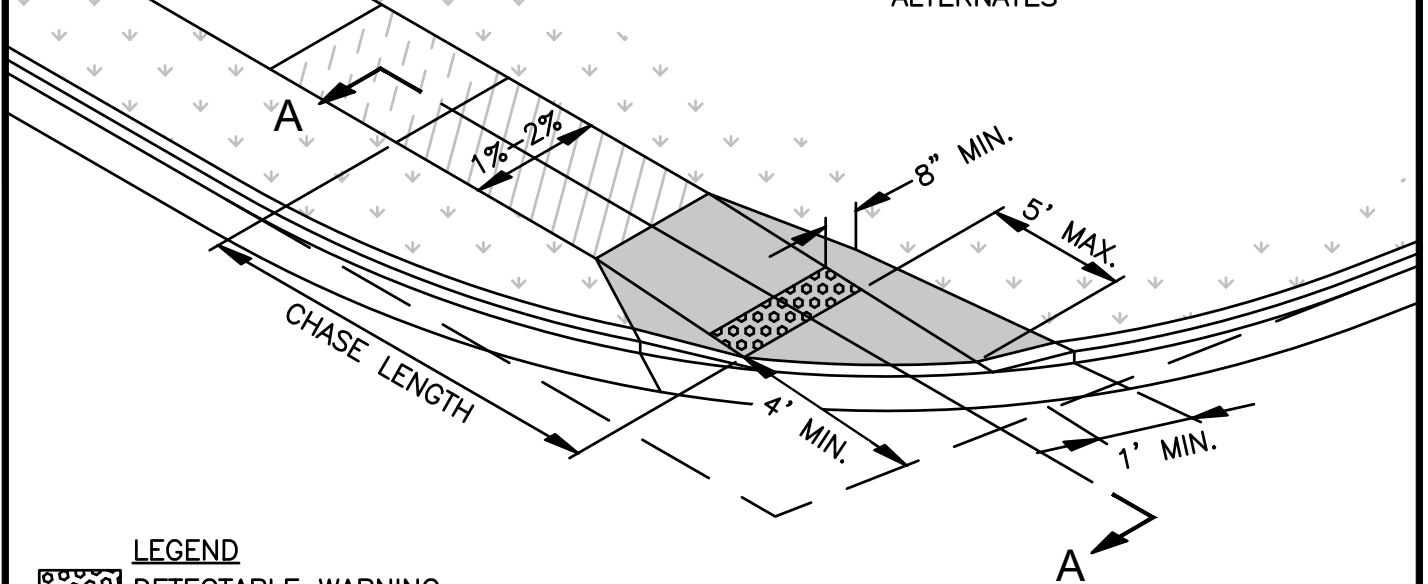

ALTERNATES



**LEGEND**

-  DETECTABLE WARNING
-  6" CURB RAMP
-  SIDEWALK
-  TRANSITION PANEL (IF NECESSARY)

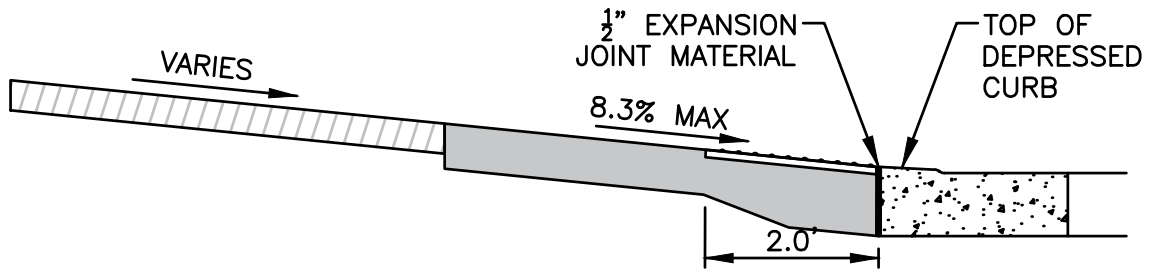

**SECTION A-A**

**NOTES:**

1. TYPICALLY USED WHERE SIDEWALK WILL ONLY EXIST ON ONE STREET AND NOT BOTH.
2. REFER TO SHEET 8 FOR ADA RAMP NOTES.
3. REFER TO SHEET 23 FOR DEPRESSED CURB AT ADA RAMP.

STANDARD DRAWING		
DATE	REVISION	BY

K-608A  
ADA RAMP SCHEMATIC



**City of Kettering**

APPROVAL



CITY ENGINEER

---

JANUARY 2019

SHEET  
**13**

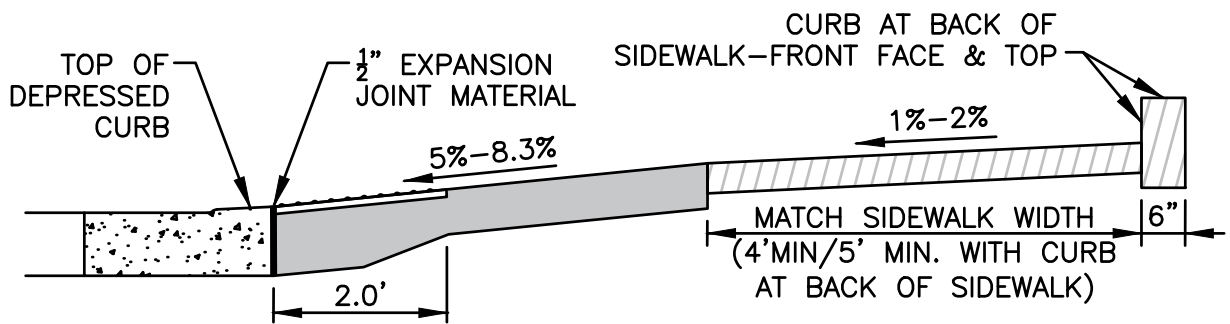
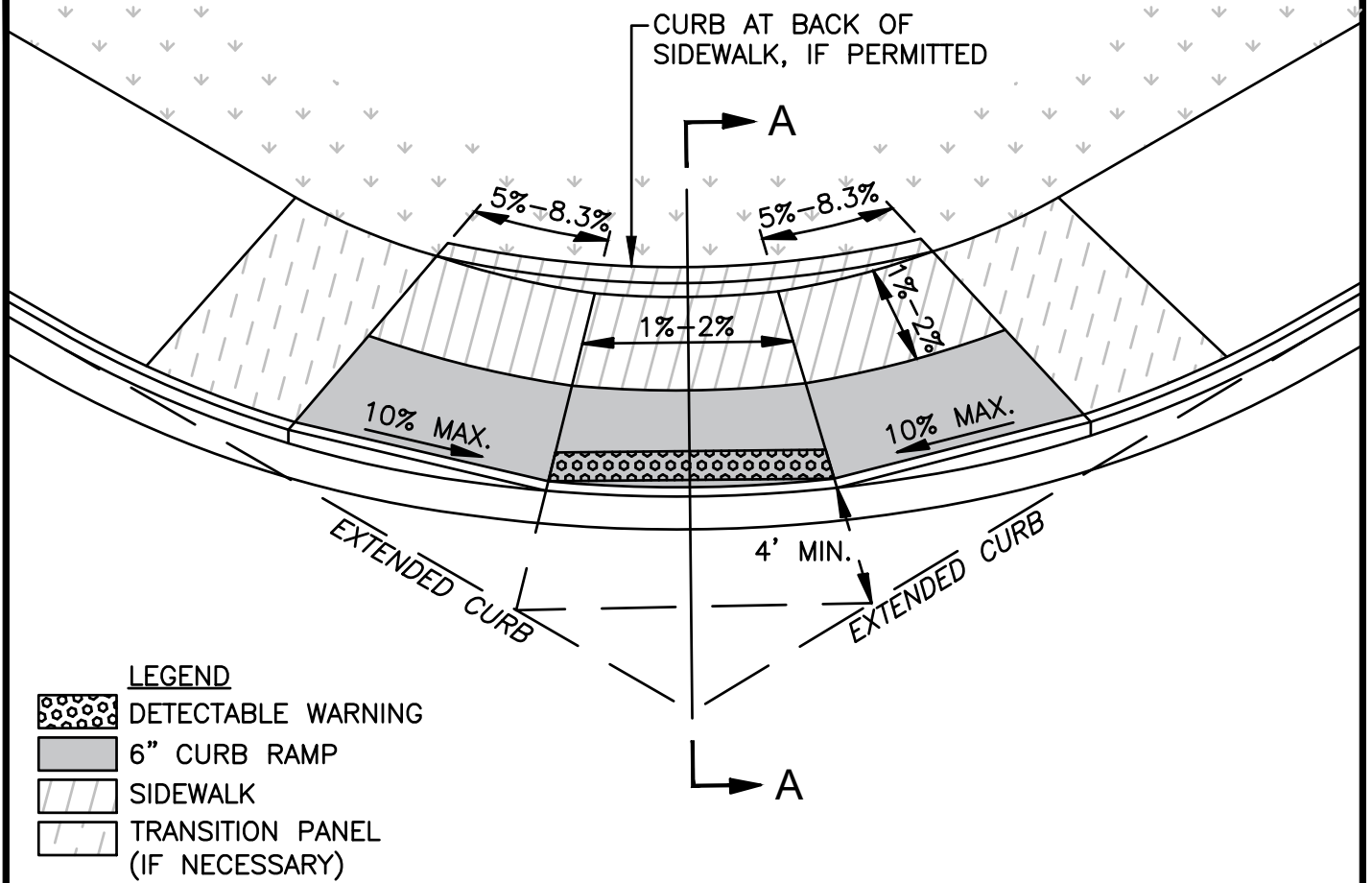

K-C1



**SECTION A-A**

**NOTES:**



1. TYPICALLY USED AT TWO STREETS OF SIMILAR CLASSIFICATION (LOCAL-LOCAL OR THOROUGHFARE-THOROUGHFARE).
2. REFER TO SHEET 7 FOR WALK ADJACENT TO CURB.
3. REFER TO SHEET 8 FOR ADA RAMP NOTES.
4. REFER TO SHEET 23 FOR DEPRESSED CURB AT ADA RAMP. MEASURE FRONT FACE AND TOP OF CURB FOR TOTAL SQUARE FOOTAGE TO BE INCLUDED IN 6" CURB RAMP QUANTITY.
5. EXPOSED CURB AT BACK OF SIDEWALK REVEAL MUST EQUAL BURIED DEPTH; 12" MAXIMUM REVEAL.

STANDARD DRAWING			K-608A ADA RAMP SCHEMATIC	APPROVAL	
DATE	REVISION	BY		 CITY ENGINEER	
			 <b>City of Kettering</b>	JANUARY 2019	SHEET 14

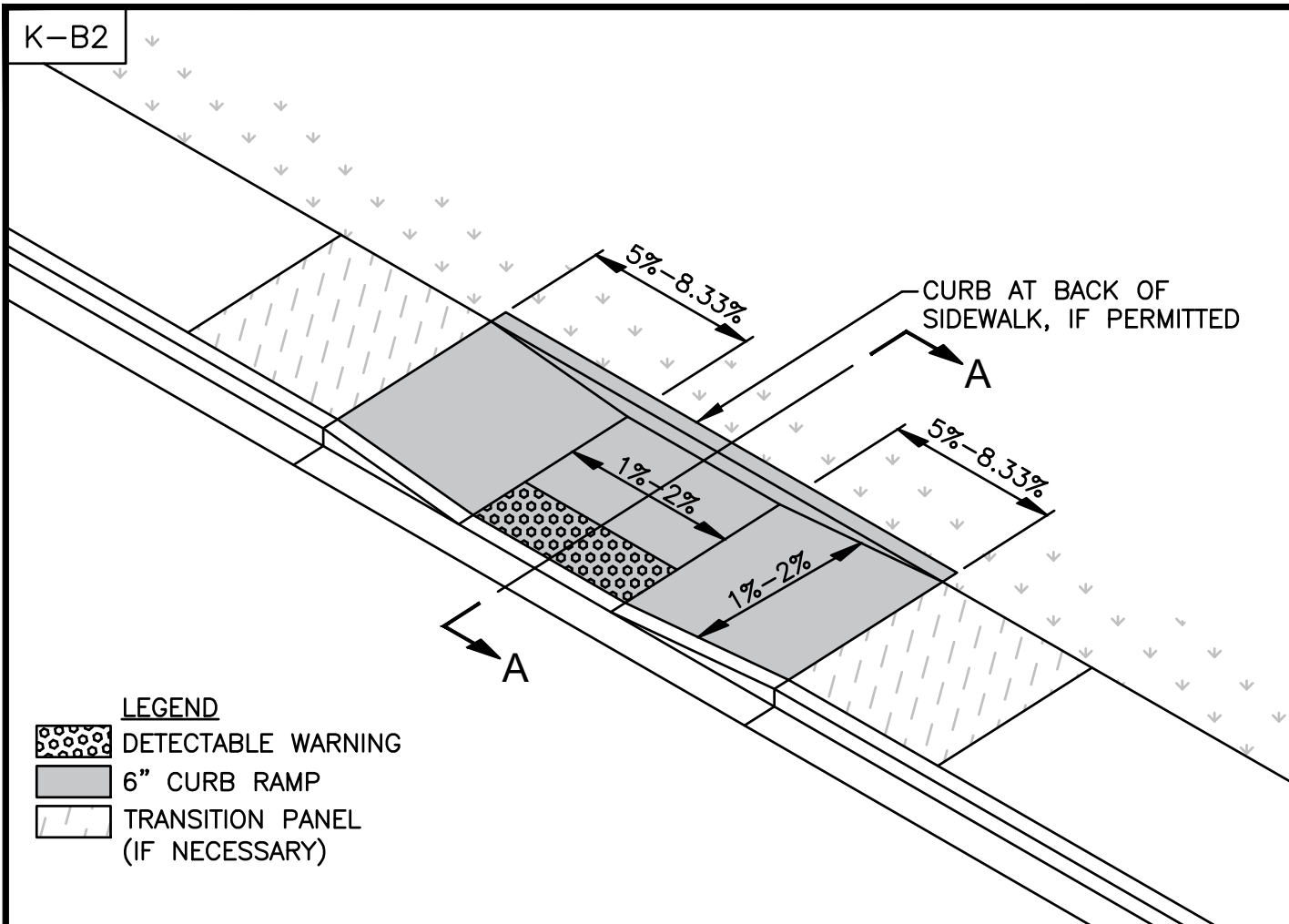

K-B2



- LEGEND**
-  DETECTABLE WARNING
  -  6" CURB RAMP
  -  TRANSITION PANEL (IF NECESSARY)

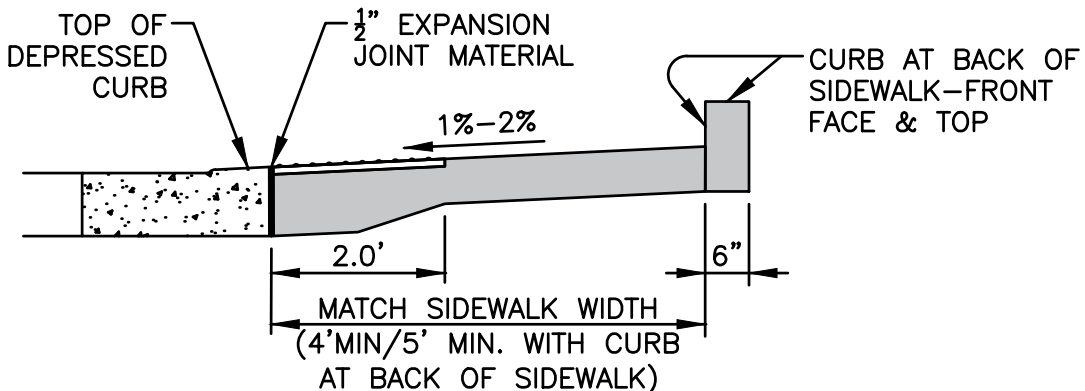

**SECTION A-A**

**NOTES:**

1. TYPICALLY USED WHERE TWO RAMPS EXIST AT ONE CORNER, OR AT MID-BLOCK CROSSWALKS.
2. REFER TO SHEET 7 FOR WALK ADJACENT TO CURB.
3. REFER TO SHEET 8 FOR ADA RAMP NOTES.
4. REFER TO SHEET 23 FOR DEPRESSED CURB AT ADA RAMP.
5. EXPOSED CURB AT BACK OF SIDEWALK REVEAL MUST EQUAL BURIED DEPTH; 12" MAXIMUM REVEAL.

STANDARD DRAWING		
DATE	REVISION	BY

K-608A  
ADA RAMP SCHEMATIC



City of Kettering

APPROVAL



CITY ENGINEER

---

JANUARY 2019

SHEET  
**15**

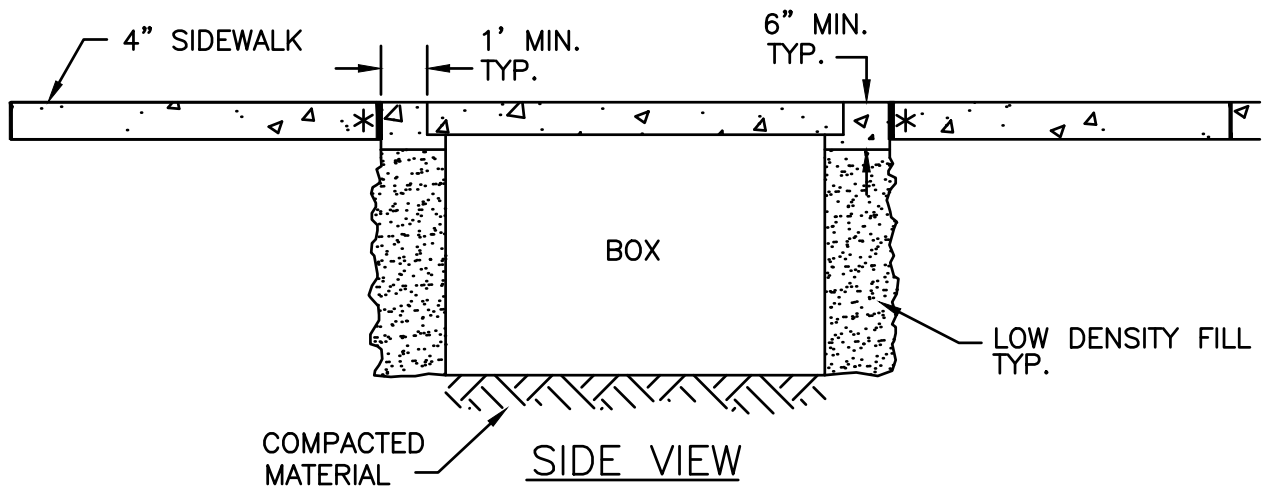
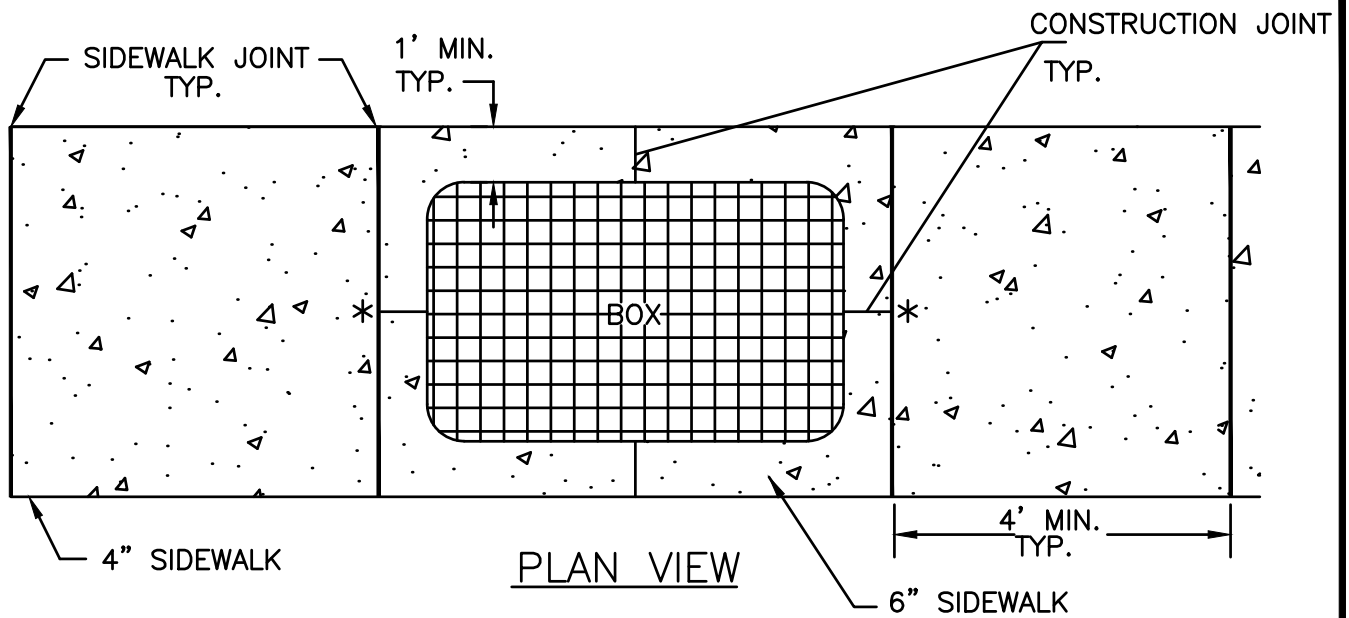

\* 1/2" EXPANSION JOINT MATERIAL

1. THIS CONCEPT ALSO APPLIES TO TWO OR MORE SIDE-TO-SIDE PULL BOXES.
2. PULL BOXES SHOULD BE PLACED IN THE SIDEWALK ONLY IF NO OTHER LOCATION IS AVAILABLE.
3. PULL BOXES SHOULD BE PLACED IN THE MIDDLE OF SIDEWALK PANELS WITH PROPER VERTICAL AND HORIZONTAL ALIGNMENT.
4. CONCRETE SHALL MEET KETTERING SPECS (K-499) AND SHALL ONLY BE SUPPLIED THROUGH AN APPROVED READYMIX SUPPLIER.

STANDARD DRAWING			K-608A UTILITY PULL BOX IN SIDEWALK	APPROVAL	SHEET 16
DATE	REVISION	BY		 CITY ENGINEER	
			 <b>City of Kettering</b>	JANUARY 2019	

## DRIVE APPROACH DETAILS

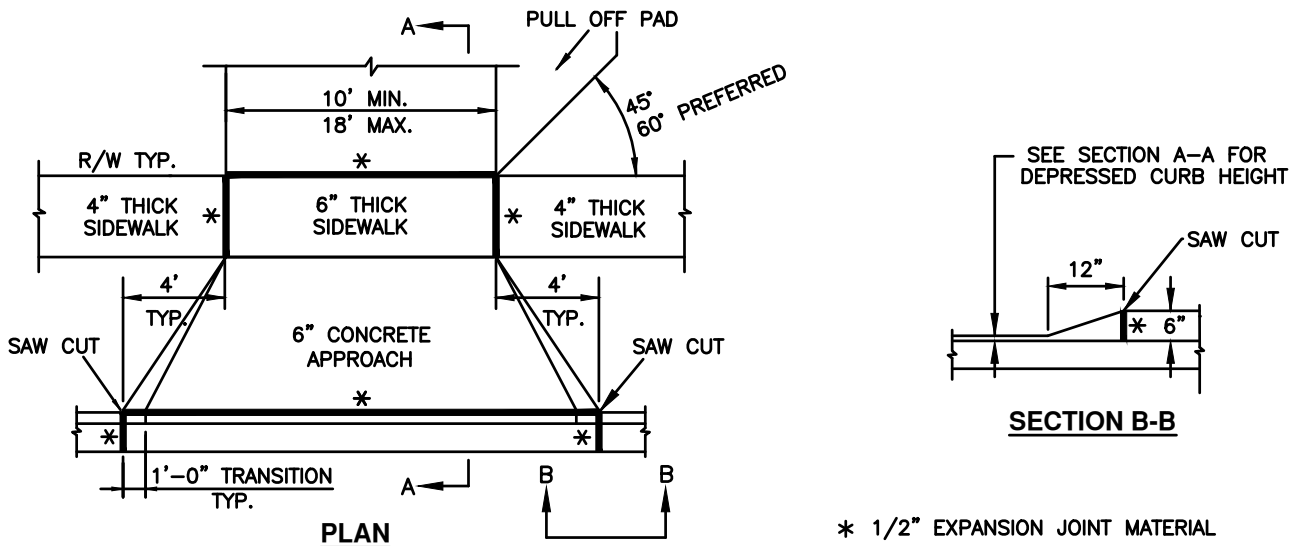

### EXISTING GUTTER PLATE EXPOSED (NOT OVERLAID WITH ASPHALT)

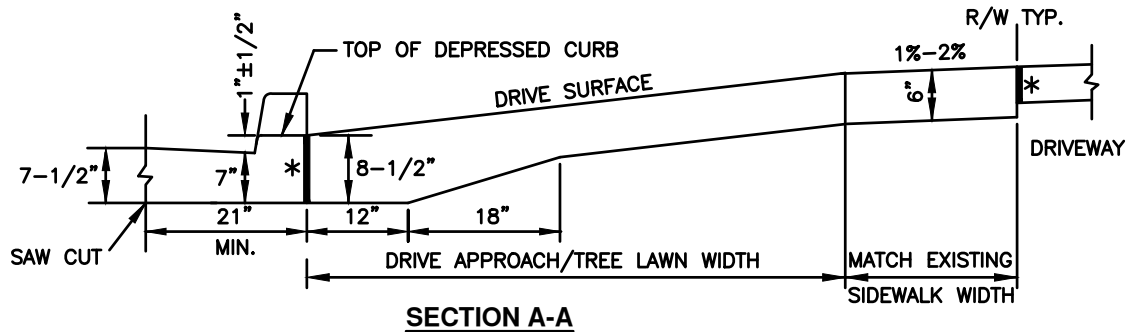

### EXISTING GUTTER PLATE OVERLAID WITH ASPHALT

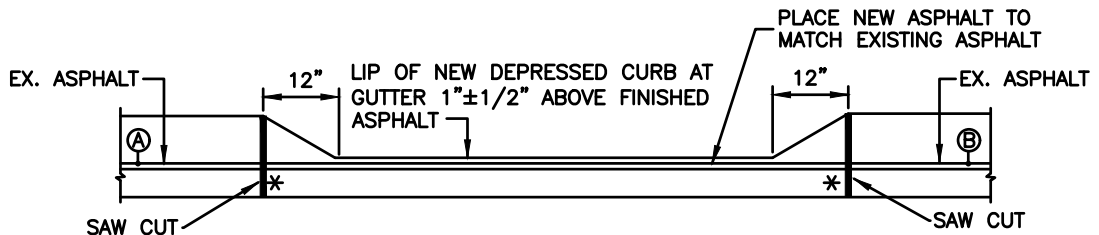
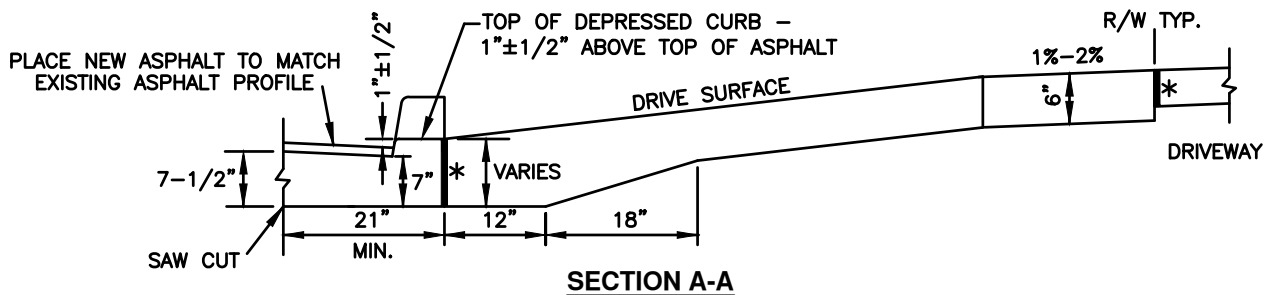

Ⓐ TO Ⓑ STRING LINE FROM Ⓐ TO Ⓑ TO MATCH EXISTING ASPHALT GRADE. USE THE STRING LINE FROM Ⓐ TO Ⓑ TO GET NEW ASPHALT GRADE IN FRONT OF DEPRESSED CURB. NEW DEPRESSED CURB LIP SHALL BE 1" ± 1/2" HIGHER THAN NEW ASPHALT.

SEE DRIVE APPROACH NOTES ON SHEET #21

STANDARD DRAWING		
DATE	REVISION	BY

K-608B RESIDENTIAL  
DRIVE APPROACH



**City of Kettering**

APPROVAL	
CITY ENGINEER	
JANUARY 2019	SHEET 17

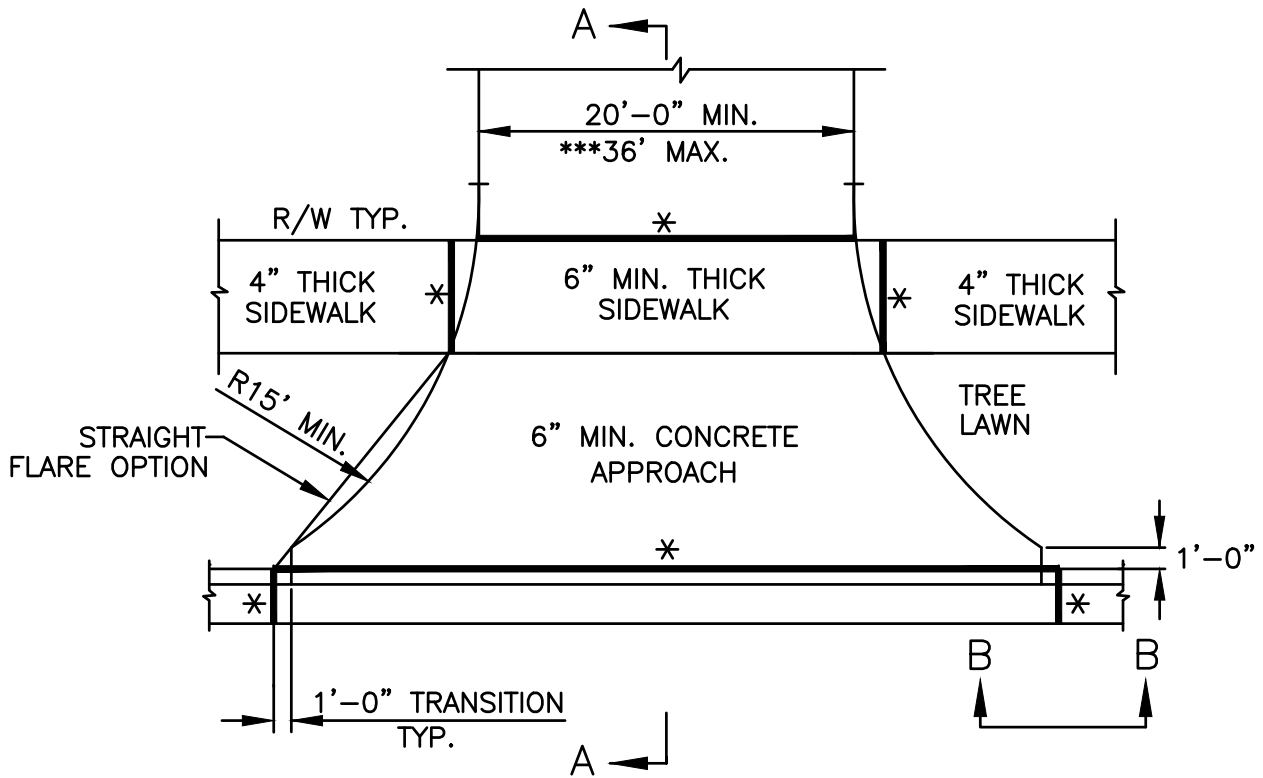

PLAN

- \* 1/2" EXPANSION JOINT MATERIAL
- \*\*\* WIDTHS LARGER THEN 36' REQUIRE APPROVAL FROM THE ENGINEER

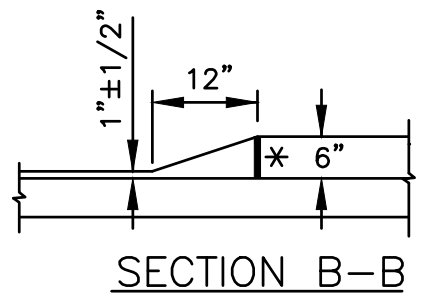

SECTION B-B

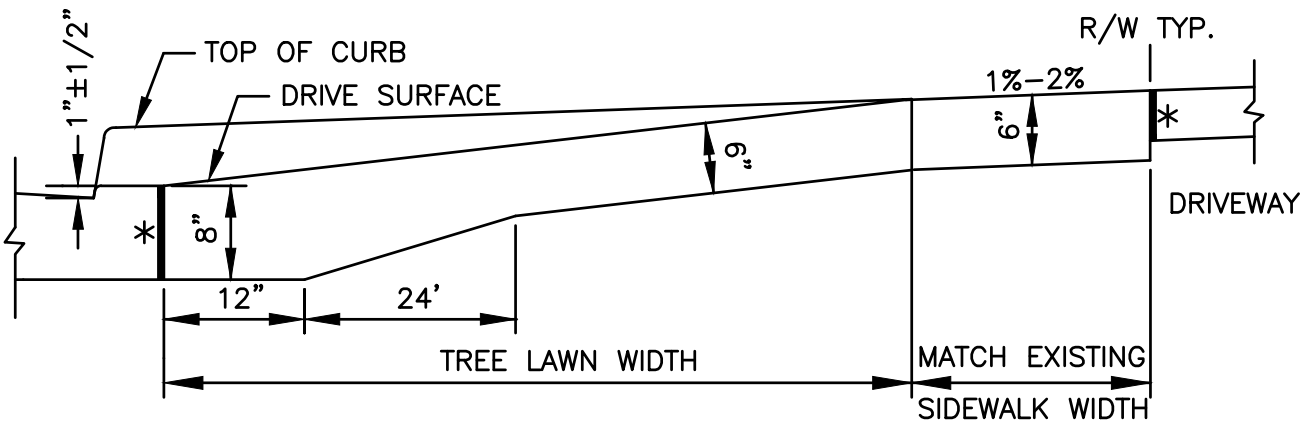

SECTION A-A

SEE DRIVE APPROACH NOTES ON SHEET #21

STANDARD DRAWING			K-608B COMMERCIAL DRIVE APPROACH	APPROVAL	
DATE	REVISION	BY		 CITY ENGINEER	
			 <b>City of Kettering</b>	JANUARY 2019	SHEET 18

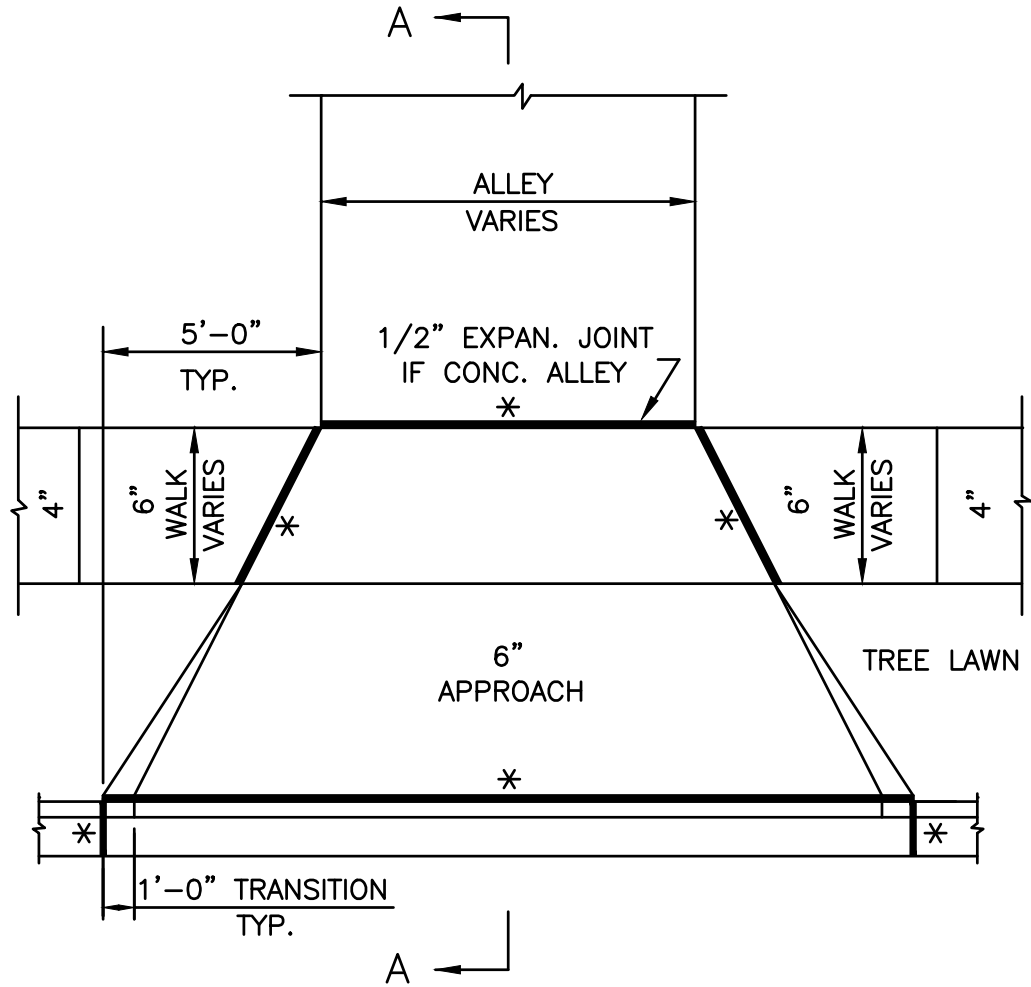

\* 1/2" EXPANSION JOINT MATERIAL

### ALLEY APPROACH DETAIL

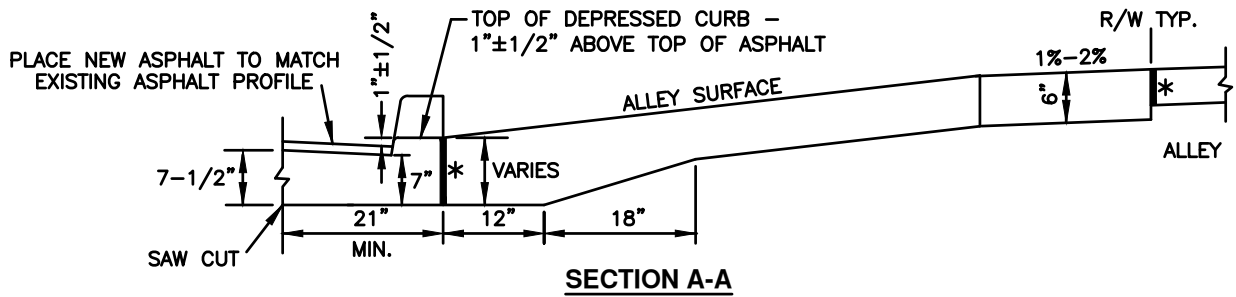

SEE DRIVE APPROACH NOTES ON SHEET #21

STANDARD DRAWING		
DATE	REVISION	BY

K-608B  
ALLEY APPROACH

City of Kettering

APPROVAL

CITY ENGINEER

---

JANUARY 2019

SHEET  
19

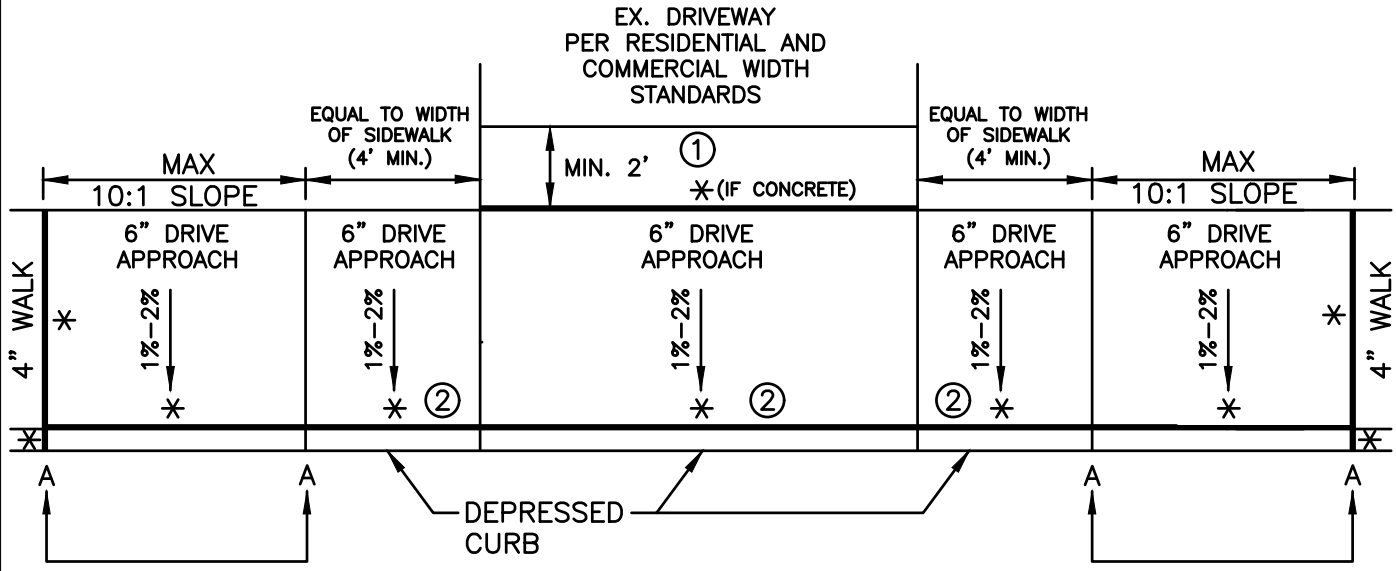

\* 1/2" EXPANSION JOINT MATERIAL

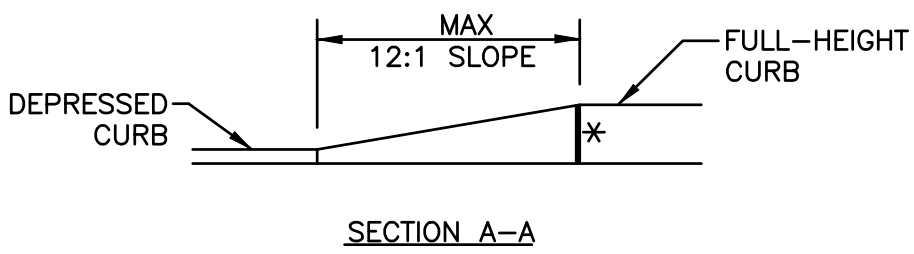

① CONTRACTOR SHALL REMOVE A MINIMUM OF 2' BEHIND WALK (OR AS DIRECTED BY ENGINEER) AND REPLACE PER KETTERING CMS K-608B.

② RESIDENTIAL AND COMMERCIAL DRIVE APPROACH CROSS SECTION THICKNESS AND CONSTRUCTION STANDARDS SHALL APPLY (SECTION A-A ON RESIDENTIAL AND COMMERCIAL STANDARD CONSTRUCTION DRAWINGS)

SEE DRIVE APPROACH NOTES ON SHEET #21

STANDARD DRAWING			K-608B DRIVE APPROACH, WALK AT BACK OF CURB	APPROVAL	
DATE	REVISION	BY		 CITY ENGINEER	
			 <b>City of Kettering</b>	JANUARY 2019	SHEET <b>20</b>

# DRIVE APPROACH NOTES

1. MAXIMUM JOINT SPACING SHALL BE 8 FEET LONGITUDINALLY AND TRANSVERSELY.
2. THE FLARE ON RESIDENTIAL DRIVE APPROACHES SHALL BE A MINIMUM OF 4 FEET. ON RESIDENTIAL STREETS WHERE THE TREE LAWN IS LESS THAN 4 FEET, THE FLARE SHALL BE A 45° ANGLE. ON ALL OTHER STREETS (I.E. NON-RESIDENTIAL) WHERE THE TREE LAWN IS LESS THAN 8 FEET, THE FLARE SHALL BE A 45° ANGLE. IF THE TREE LAWN IS GREATER THAN 8 FEET THE FLARE SHALL BE AT THE DISCRETION OF THE ENGINEER.
3. THE SUBGRADE BENEATH THE PROPOSED DRIVE APPROACH IS TO BE COMPACTED TO THE MAXIMUM EXTENT PRACTICAL. A MINIMUM OF 3" OF GRAVEL (OR CRUSHED AGGREGATE) BASE SHALL BE PLACED UNDER THE DRIVE APPROACH IF DETERMINED NECESSARY BY THE ENGINEER.
4. CONCRETE SHALL MEET SPECS K-499 AND SHALL ONLY BE SUPPLIED THROUGH AN APPROVED READY MIX SUPPLIER.
5. WHERE ASPHALT CONCRETE PAVEMENT IS DISTURBED, THE ASPHALT SHALL HAVE A SAWED EDGE, BE REPLACED AND SEALED AS DIRECTED BY THE ENGINEER.
6. SAW CUT CURB AT BOTH ENDS. SAW CUT SHALL HAVE CLEAN AND STRAIGHT EDGES, AND SHALL BE THE FULL DEPTH OF THE CURB.
7. FOR CURB MONOLITHIC WITH CONCRETE STREET, SAW CUT PAVEMENT 21" FROM BACK OF CURB. SAW CUT TO HAVE CLEAN AND STRAIGHT EDGES, AND SHALL BE FULL DEPTH OF CURB AND PAVEMENT.
8. EXPANSION JOINT MATERIAL SHALL BE PLACED AS SHOWN ON SHEETS 20-24.
9. ANY TOOL MARKS LEFT BY EDGING SHALL BE ELIMINATED BY TEXTURING THE SURFACE. THE FINAL SURFACE SHALL BE BROOM FINISHED. RETOOLED JOINTS SHALL NOT BE CONSTRUCTED UNLESS APPROVED BY THE ENGINEER.
10. IF AN EXISTING SIDEWALK IS PRESENT THROUGH THE DRIVE, THE THE DRIVE APPROACH SHALL BE PLACED IN CONCRETE.
11. PATCH REPAIRS MAY ONLY BE USED AS A TEMPORARY MEASURE UNTIL REPLACEMENT IS POSSIBLE. ONCE PART OF A DRIVE APPROACH IS EXCAVATED, THE FULL DRIVE APPROACH IS TO MEET CURRENT SPECIFICATIONS. NO EXCAVATION MAY BE LESS THAN AN AREA CREATED BY STANDARD JOINT CONSTRUCTION. INTEGRAL DRIVE APPROACHES ARE NOT PERMITTED.

STANDARD DRAWING			K-608B		APPROVAL	
DATE	REVISION	BY	DRIVE APPROACH NOTES		 CITY ENGINEER	
			 <b>City of Kettering</b>		JANUARY 2019	SHEET <b>21</b>

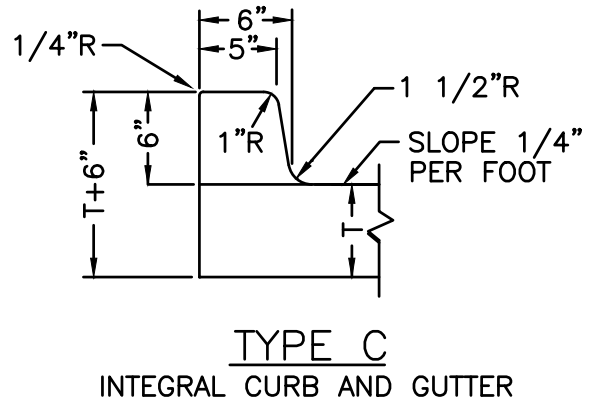
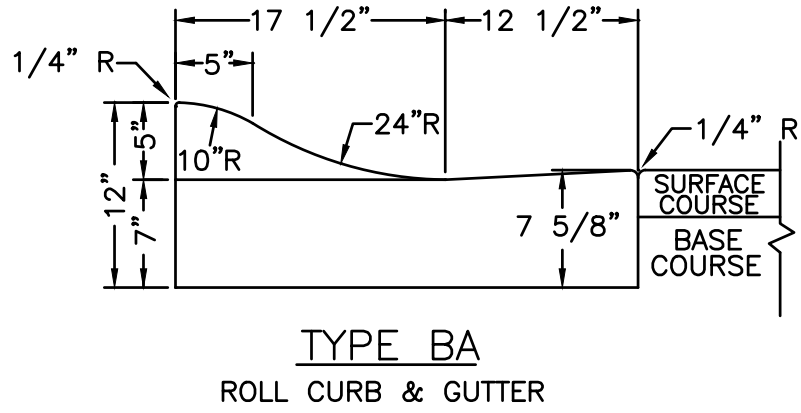
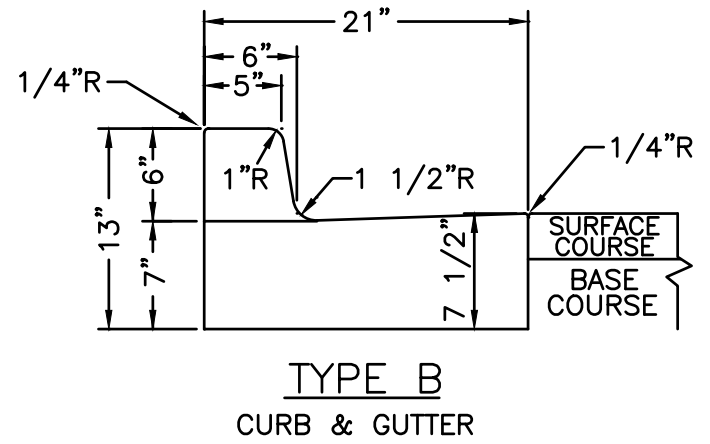
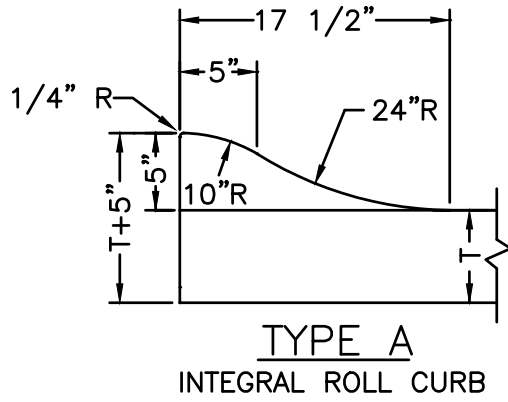

SEE CURB & GUTTER NOTES ON SHEET #27

STANDARD DRAWING			K-609 CURB AND GUTTER	APPROVAL	
DATE	REVISION	BY		 CITY ENGINEER	
			 <b>City of Kettering</b>	JANUARY 2019	SHEET <b>22</b>



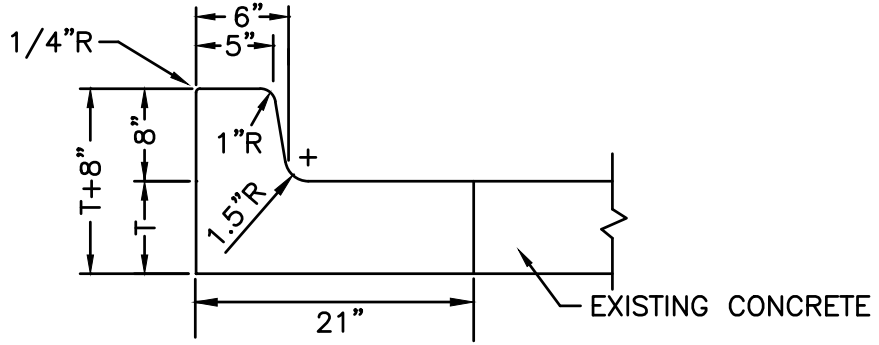

MODIFIED TYPE B  
CURB AND GUTTER

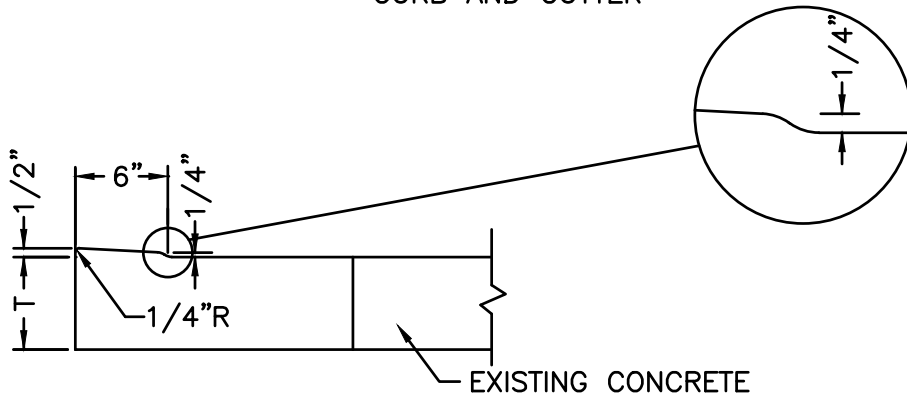

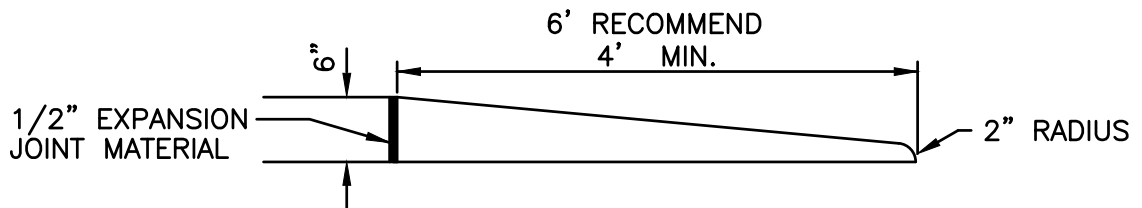

DEPRESSED CURB  
AT ADA RAMP



END CURB DETAIL

SEE CURB & GUTTER NOTES ON SHEET #27

2 of 2

STANDARD DRAWING			K-609 CURB AND GUTTER	APPROVAL	
DATE	REVISION	BY		 CITY ENGINEER	
			 <b>City of Kettering</b>	JANUARY 2019	SHEET <b>23</b>

## CURB AND GUTTER NOTES

1. ANY VARIANCES FROM THESE STANDARDS REQUIRE APPROVAL BY THE ENGINEER.
2. USE OF EXTRUDED CURB REQUIRES APPROVAL BY THE ENGINEER.
3. ON CONCRETE STREETS, TRANSVERSE JOINTS SHALL BE EXTENDED THROUGH INTEGRAL CURBS. JOINTS IN ODOT TYPE 6 AND MODIFIED TYPE C CURB SHALL BE PLACED IN LINE WITH TRANSVERSE CONCRETE PAVEMENT JOINTS.
4. ON ASPHALT STREETS, TYPE B & BA AND ODOT TYPE 6 MEDIAN CURB SHALL HAVE JOINTS AT A MAXIMUM OF EVERY 10 FEET.
5. THE SUBGRADE BENEATH THE PROPOSED CURB & GUTTER IS TO BE COMPACTED TO THE MAXIMUM EXTENT PRACTICAL. A MINIMUM OF 3" OF GRAVEL (OR CRUSHED AGGREGATE) BASE SHALL BE PLACED UNDER THE CURB & GUTTER IF DETERMINED NECESSARY BY THE ENGINEER.
6. ONE-HALF INCH EXPANSION JOINT MATERIAL OR OTHER APPROVED EXPANSION JOINT MATERIAL SHALL BE USED WITH COMBINED CURB & GUTTER AND MEDIAN CURB AS FOLLOWS (TYPE B, BA & ODOT TYPE 6):
  - \* EACH SIDE OF DEPRESSED CURB
  - \* AT P.C. POINTS AND MEDIAN RADII
  - \* AT EACH SIDE OF DRIVE APPROACH AND CATCH BASINS
  - \* MAXIMUM SPACING SHALL NOT EXCEED 50 FEET
  - \* THE MATERIAL SHALL BE PLACED STRAIGHT AND SQUARE THROUGHOUT THE ENTIRE CURB SECTION.
7. ALL CURBS SHALL BE BACKFILLED PRIOR TO PAVING AND/OR BEFORE THEY ARE TO SUPPORT ANY VEHICULAR TRAFFIC.
8. DRAIN TILE THROUGH THE CURB SHALL BE INSTALLED ONLY WHEN APPROVED BY THE ENGINEER. DRAIN TILE THROUGH CURB SHALL HAVE A MIN. OF 3" OF COVER. UNLESS WAIVED BY THE ENGINEER, A CONTRACTION JOINT SHALL BE PLACED OVER THE OPENING AND THE GUTTER PANEL.
9. USE ODOT BP-2.1 HOOK BOLT OR APPROVED ALTERNATE AS REQUIRED IN THESE STANDARD DRAWINGS OR BY THE ENGINEER.
10. CONCRETE SHALL MEET KETTERING SPECS K-499 AND SHALL ONLY BE SUPPLIED THROUGH AN APPROVED READY MIX SUPPLIER.
11. CONCRETE CURB (AND GUTTER) SPOT REPLACEMENT SECTIONS SHALL BE A MINIMUM OF THREE (3) FEET IN LENGTH. THE REPLACEMENT SECTION SHALL BE EXTENDED TO THE NEAREST EXISTING JOINT IF THE END OF THE REPLACEMENT SECTION IS WITHIN TWO (2) FEET OF THE NEAREST EXISTING JOINT.
12. THE SUBGRADE BENEATH CURB (AND GUTTER) SPOT REPLACEMENT SECTIONS SHALL BE FULLY COMPACTED TO THE MAXIMUM EXTENT PRACTICABLE BEFORE NEW CONCRETE IS PLACED. APPROVED GRANULAR MATERIAL SHALL BE USED TO PREPARE THE SUBGRADE, IF THE EXISTING SUBGRADE IS DETERMINED TO BE UNSUITABLE BY THE ENGINEER.

STANDARD DRAWING			K-609		APPROVAL	
DATE	REVISION	BY	CURB AND GUTTER NOTES		 CITY ENGINEER	
			 <b>City of Kettering</b>		JANUARY 2019	SHEET <b>24</b>

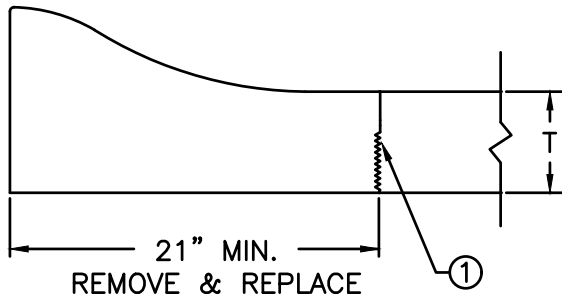

TYPE A  
INTEGRAL ROLL CURB

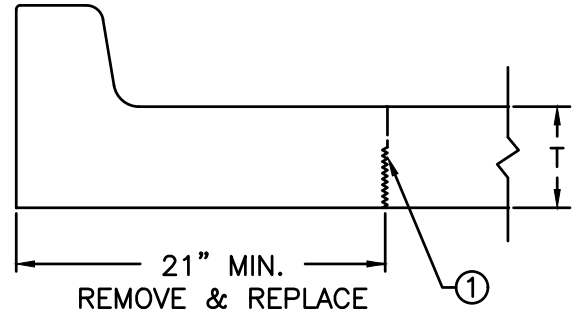

TYPE C  
INTEGRAL CURB AND GUTTER

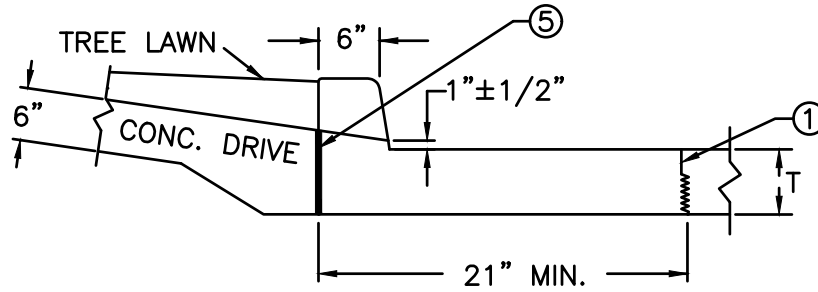

DRIVE PROFILE

CURB AND GUTTER REPAIR NOTES

1. SAWCUT DEPTH FOR REMOVAL SHALL BE GREATER OF EITHER 3" OR T/3.
2. CONCRETE CURB (AND GUTTER) SPOT REPLACEMENT SECTIONS SHALL BE A MINIMUM OF THREE (3) FEET IN LENGTH. THE REPLACEMENT SECTION SHALL BE EXTENDED TO THE NEAREST EXISTING JOINT IF THE END OF THE REPLACEMENT SECTION IS WITHIN TWO (2) FEET OF THE NEAREST EXISTING JOINT.
3. WHEN EXISTING CURB & GUTTER AND CONCRETE DRIVE ARE MONOLITHIC REMOVE CURB & GUTTER TO PROJECTED BACK OF CURB, SAW FULL DEPTH AND USE APPROVED 1/2" EXPANSION JOINT MATERIAL OR APPROVED EQUAL.
4. WHERE EXPANSION JOINT MATERIAL IS TO BE INSTALLED, SAWCUTS SHALL BE FULL DEPTH.
5. ONE-HALF-INCH (1/2") EXPANSION MATERIAL SHALL BE PLACED ON ONE SIDE OF A SPOT REPLACEMENT SECTION, IF THE REPLACEMENT SECTION IS 15 FEET OR LESS IN LENGTH. FOR REPLACEMENT SECTIONS GREATER THAN 15 FEET IN LENGTH, 1/2" VINYL EXPANSION MATERIAL SHALL BE PLACED ON BOTH SIDES OF THE REPLACEMENT SECTION.
6. CONCRETE SHALL MEET KETTERING SPECS K-499 AND SHALL ONLY BE SUPPLIED THROUGH AN APPROVED READY MIX SUPPLIER.

STANDARD DRAWING		
DATE	REVISION	BY

K-609  
CURB AND GUTTER REPAIR  
CONCRETE STREETS

 **City of Kettering**

APPROVAL  
  
CITY ENGINEER

JANUARY 2019

SHEET  
**25**

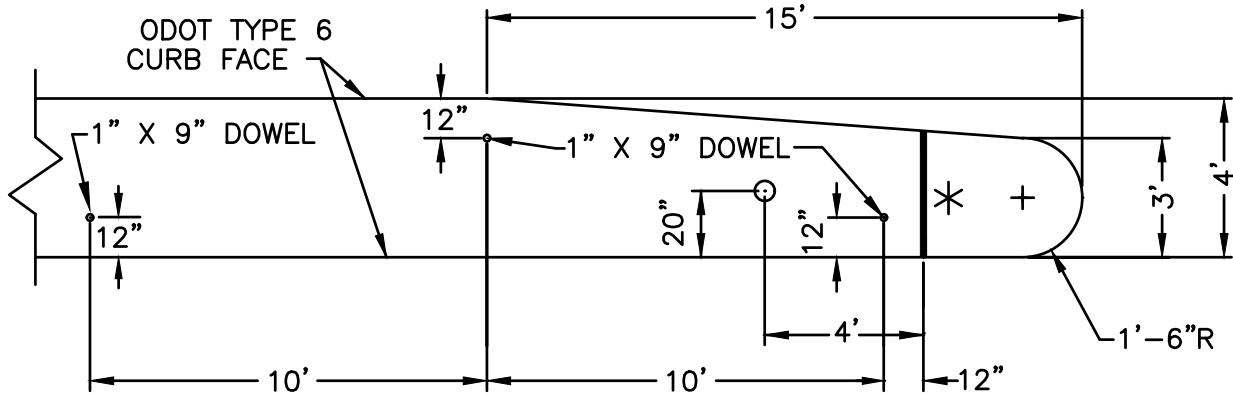

TOP VIEW

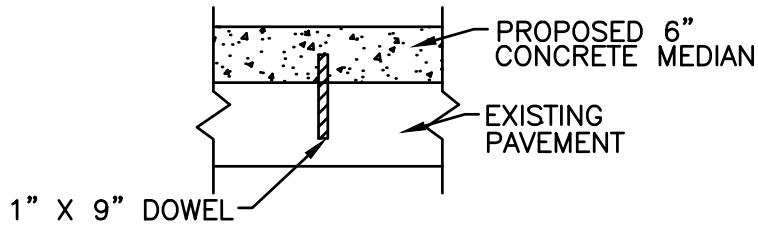

DOWEL DETAIL ③

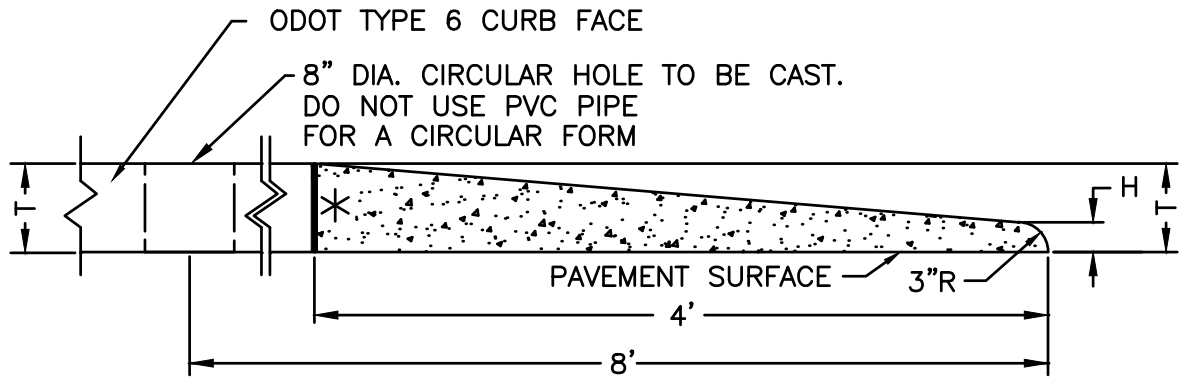

SIDE VIEW

\* 1/2" EXPANSION JOINT MATERIAL



T = 6" WHEN PLACED ON CONCRETE PAVEMENT.

T = 8" WHEN PLACED ON #301 ASPHALT BASE TO ALLOW FOR 2" FINAL COURSE.

H = 2" WHEN PLACED ON CONCRETE PAVEMENT,

H = 4" WHEN ALLOWING FOR 2" FINAL COURSE.

NOTE: DOWELS IN MEDIAN SHALL BE PLACED AS DIRECTED BY ENGINEER  
ALL DOWELS TO BE EPOXY COATED, SMOOTH.

STANDARD DRAWING			K-609 MEDIAN NOSE CONCRETE	APPROVAL	
DATE	REVISION	BY		 CITY ENGINEER	
			 <b>City of Kettering</b>	JANUARY 2019	SHEET 26

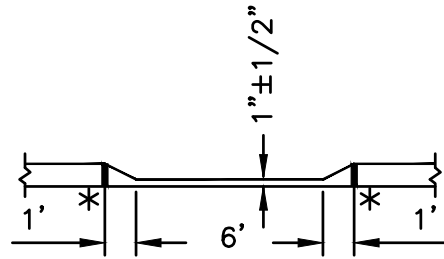



MOWER RAMP DETAIL

LOCATION OF RAMP TO BE DETERMINED BY ENGINEER

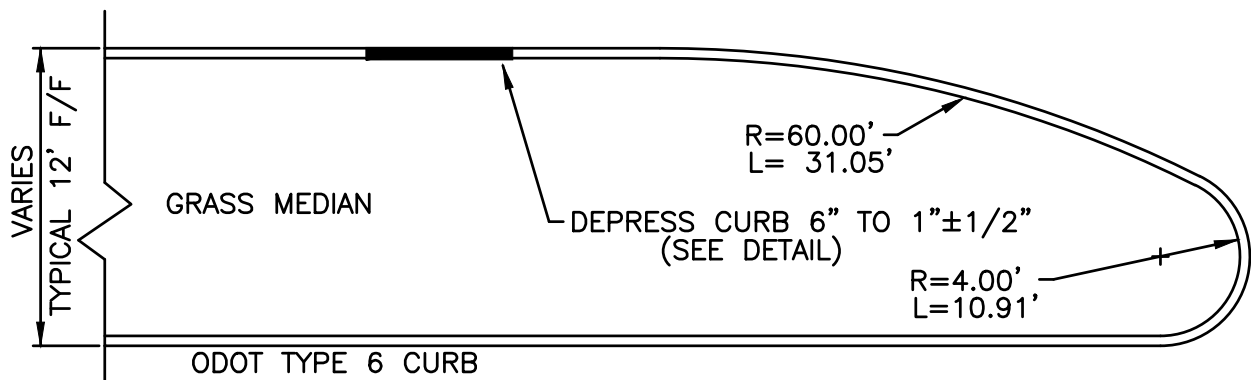
\* EXPANSION MATERIAL



GRASS MEDIAN END DETAIL

STANDARD DRAWING			K-609 MEDIAN NOSE GRASS	APPROVAL	
DATE	REVISION	BY		 CITY ENGINEER	
			 <b>City of Kettering</b>	JANUARY 2019	SHEET <b>27</b>

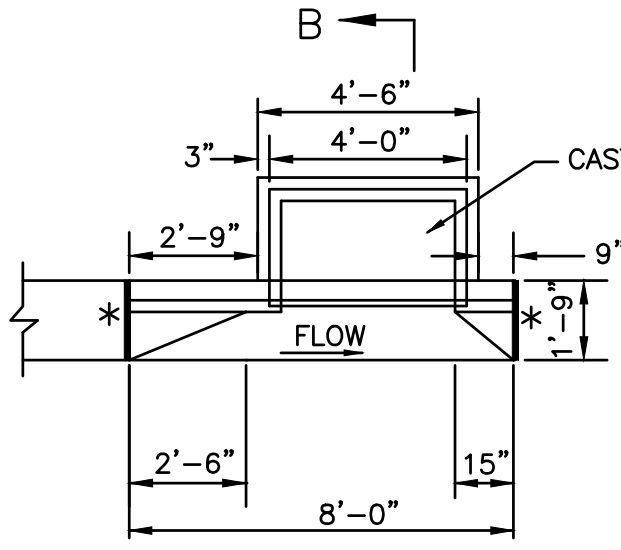

B  
PLAN VIEW

CASTING - EAST JORDAN (HD SUPPLY)  
-7485 HEAVY DUTY  
NEENAH  
-R-3312-A HEAVY DUTY  
OR APPROVED EQUAL

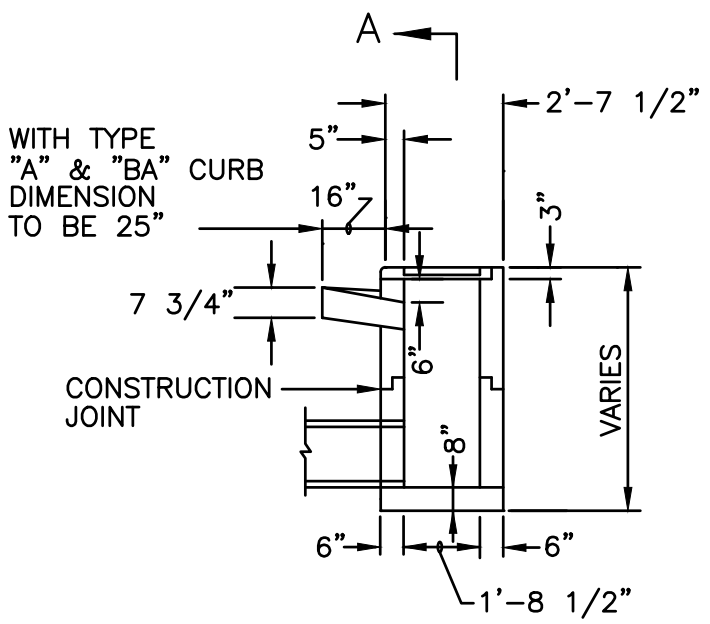

A  
SECTION B-B

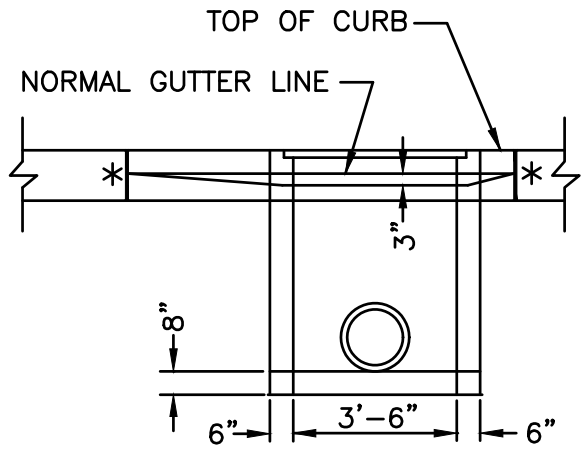

SECTION A-A

\* 1/2" EXPANSION JOINT MATERIAL

TO BE USED ONLY BY APPROVAL OF THE ENGINEER

STANDARD DRAWING		
DATE	REVISION	BY

K-611  
CATCH BASIN TYPE A

City of Kettering

APPROVAL  
*Steve E. Ryan*  
CITY ENGINEER

JANUARY 2019

SHEET  
**28**

\* 1/2" EXPANSION JOINT MATERIAL

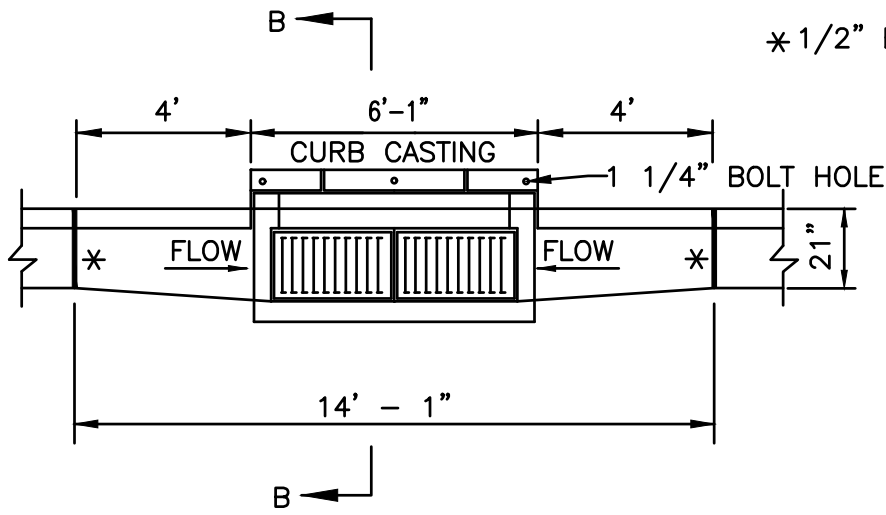

PLAN VIEW

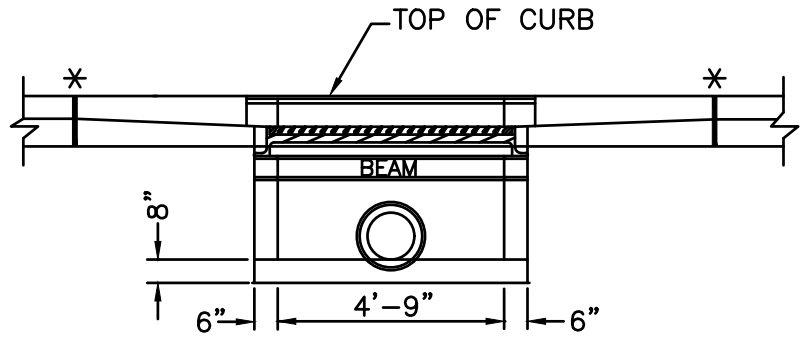

SECTION A-A

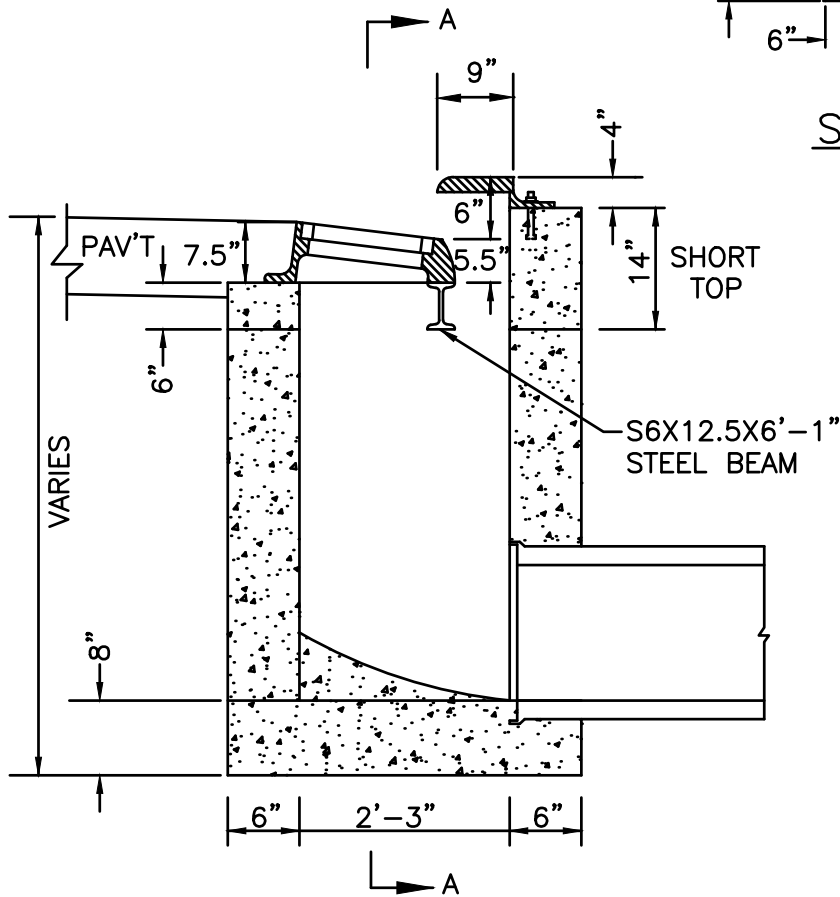



SECTION B-B

1. THIS IS ODOT STANDARD TYPE 3, EXCEPT CURB AND PRECAST TOP ARE MODIFIED AS SHOWN.
2. ALL WALLS TO BE 6" IF PRECAST AND 8" IF POURED IN PLACE OR SOLID BLOCK (POURED 8" BASE ONLY, NO BLOCK BELOW THE TOP OF PIPE).
3. LOW POINT GRATE TO BE ADJUSTED ACCORDING TO FLOW DIRECTION.
4. FRAME AND GRATE SHALL BE NEENAH R-3288-HV2, OR EAST JORDAN 7358 (WITH M3 GRATE), OR APPROVED EQUAL.
5. CURB TRANSITIONS SHALL BE MEASURED AND PAID FOR UNDER ITEM K-609 CURB (AS PER PLAN)

STANDARD DRAWING		
DATE	REVISION	BY

K-611  
CATCH BASIN TYPE 3  
KETTERING MODIFIED

 **City of Kettering**

APPROVAL  
  
CITY ENGINEER

JANUARY 2019

SHEET  
**29**

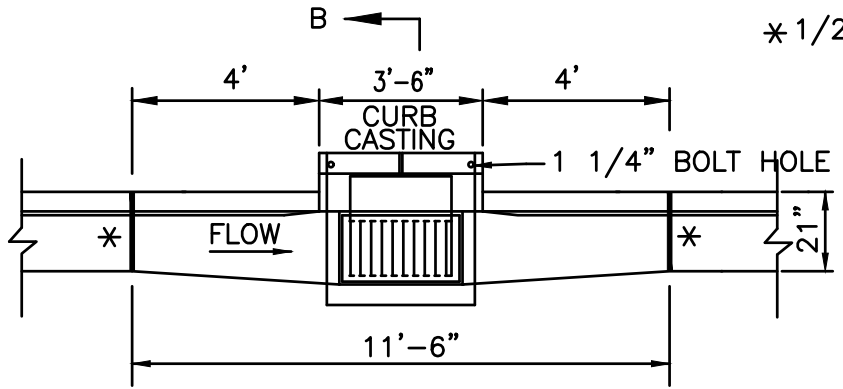

\* 1/2" EXPANSION JOINT MATERIAL

PLAN VIEW

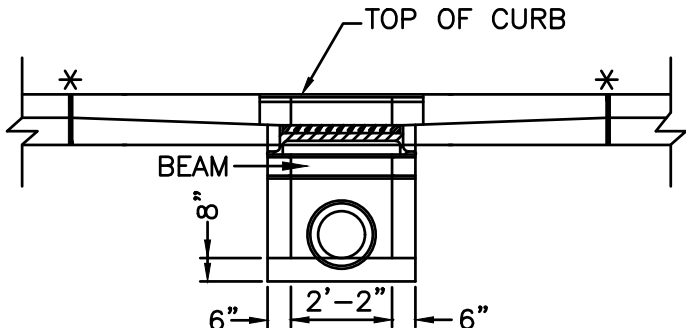

SECTION A-A

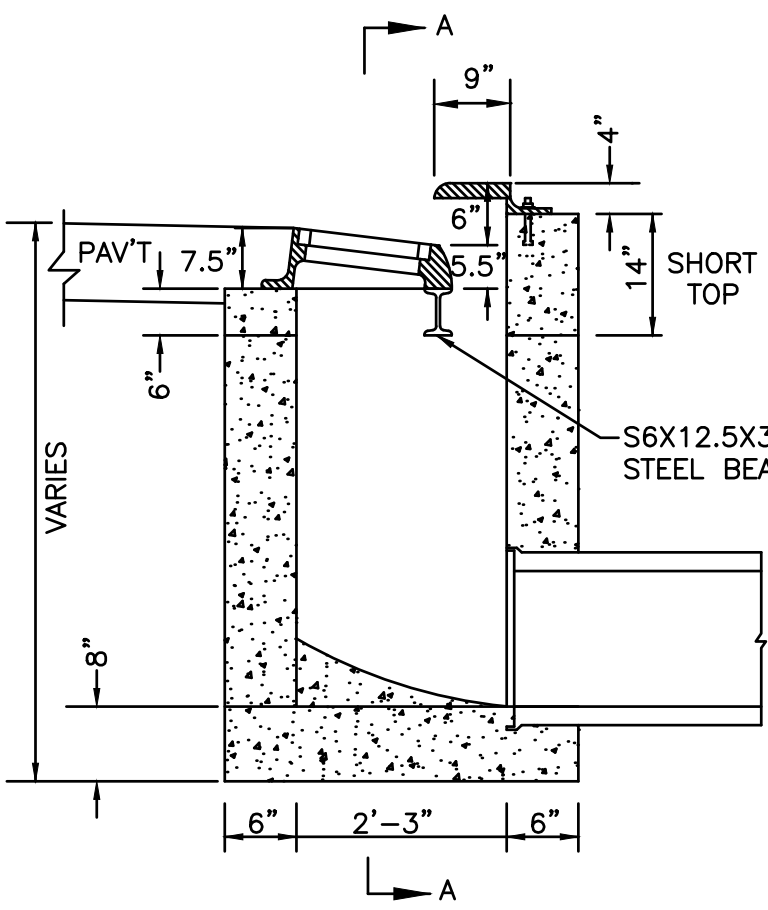

SECTION B-B

1. THIS IS ODOT STANDARD TYPE 3A, EXCEPT CURB AND PRECAST TOP ARE MODIFIED AS SHOWN.
2. ALL WALLS TO BE 6" IF PRECAST AND 8" IF POURED IN PLACE OR SOLID BLOCK (POURED 8" BASE ONLY, NO BLOCK BELOW THE TOP OF PIPE).
3. FRAME AND GRATE SHALL BE NEENAH R-3289-HV2, OR EAST JORDAN 7350 (WITH M3 GRATE), OR APPROVED EQUAL.
4. CURB TRANSITIONS SHALL BE MEASURED AND PAID FOR UNDER ITEM K-609 CURB (AS PER PLAN)

STANDARD DRAWING		
DATE	REVISION	BY

K-611  
CATCH BASIN TYPE 3A  
KETTERING MODIFIED

City of Kettering

APPROVAL

CITY ENGINEER

JANUARY 2019
SHEET 30



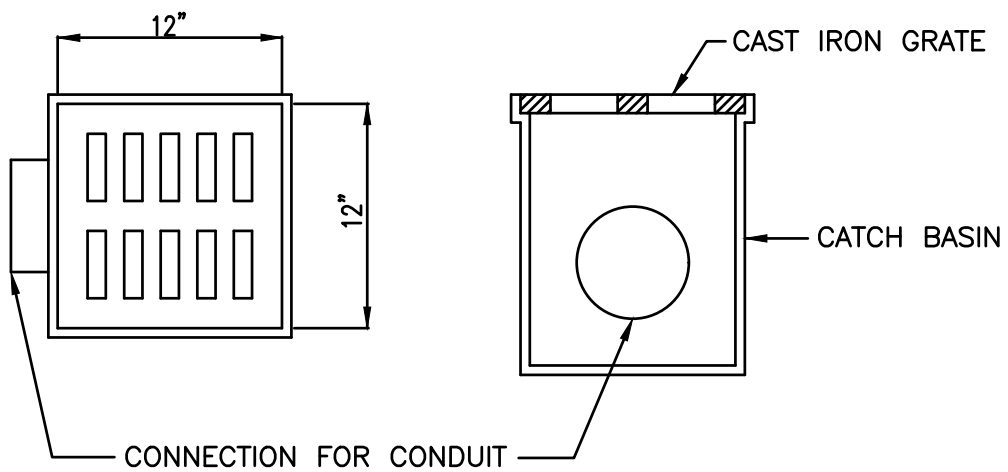

1. USE NATIONAL DIVERSIFIED SALES NDS #1200 CATCH BASIN AND NDS #1213 GRATE, OR APPROVED EQUAL.
2. SPECIAL FITTINGS, RISERS, CONNECTIONS, BENDS, TEES, CLEAN-OUTS AND APPURTENNANCES TO BE INCLUDED IN THE UNIT BID PRICE FOR YARD INLET.

STANDARD DRAWING			K-611 YARD INLET	APPROVAL <i>John E. Ryan</i> CITY ENGINEER	
DATE	REVISION	BY		 <b>City of Kettering</b>	JANUARY 2019

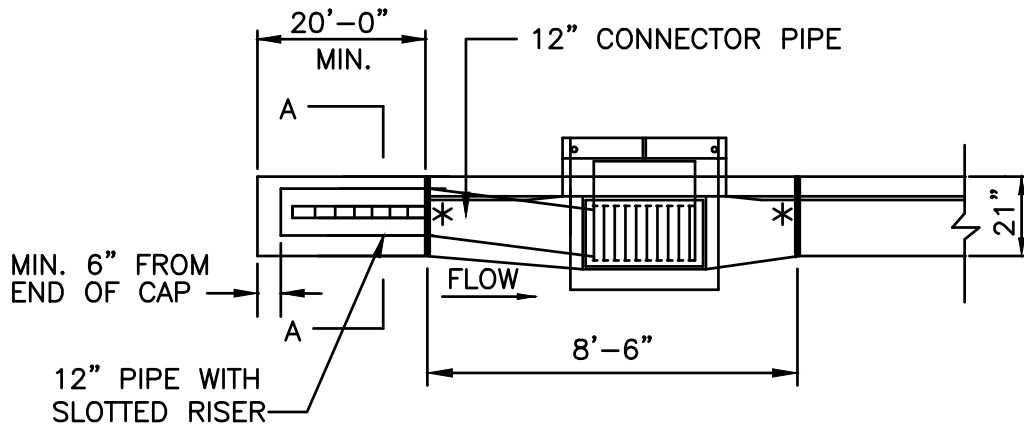

PLAN VIEW

\* 1/2" EXPANSION MATERIAL JOINT

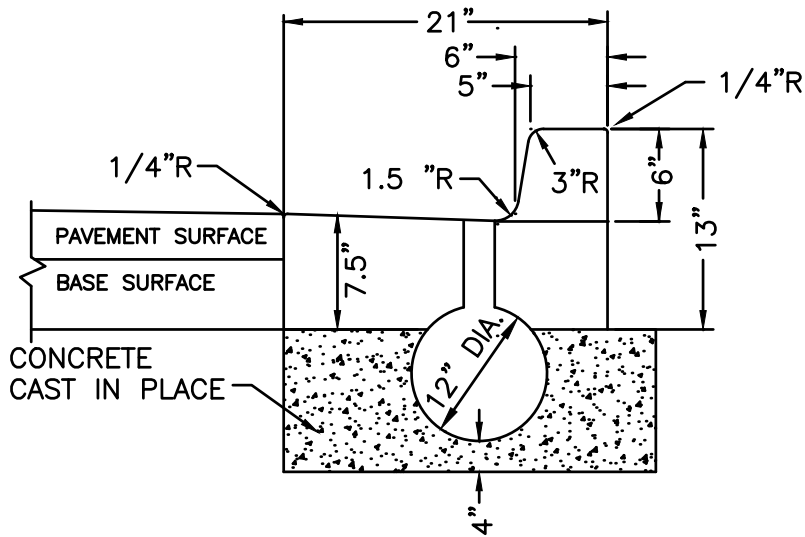

SECTION A-A

STANDARD DRAWING		
DATE	REVISION	BY

K-611  
12" SLOTTED DRAIN



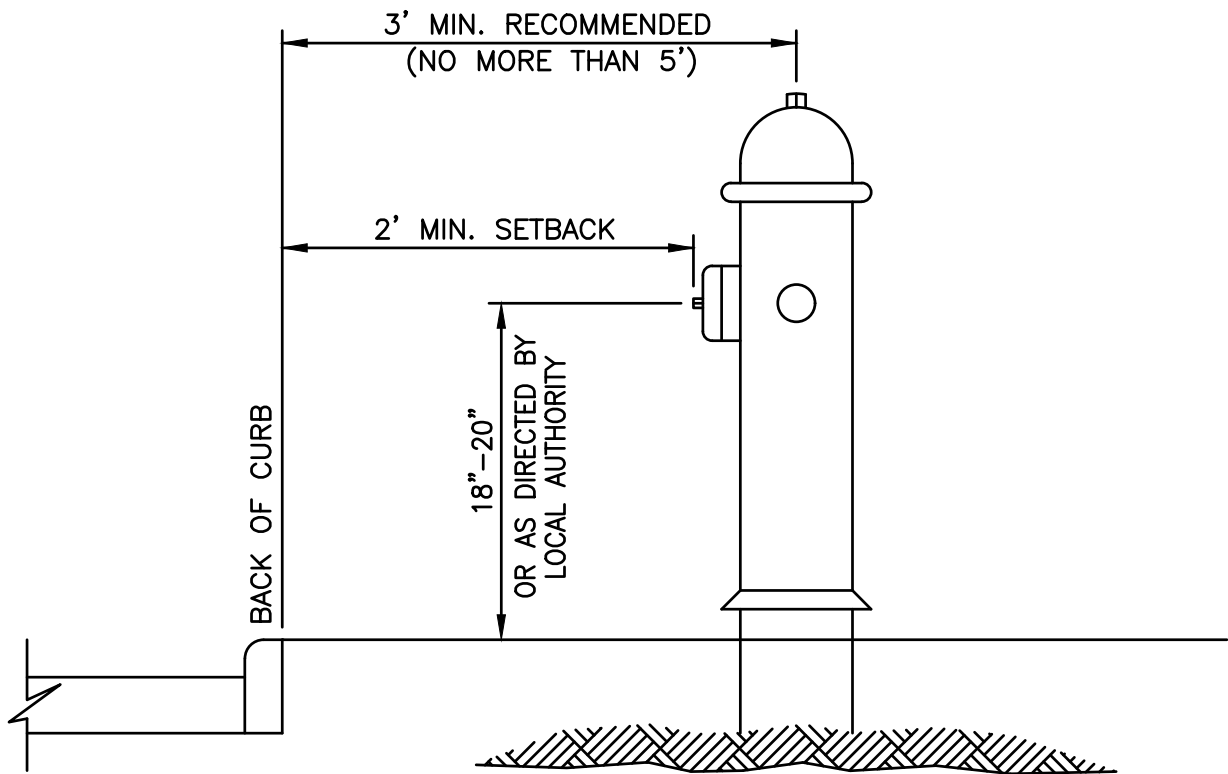

City of Kettering

APPROVAL	
 CITY ENGINEER	
JANUARY 2019	SHEET 32



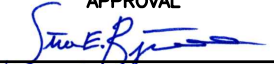

FIRE HYDRANT LOCATION DETAIL

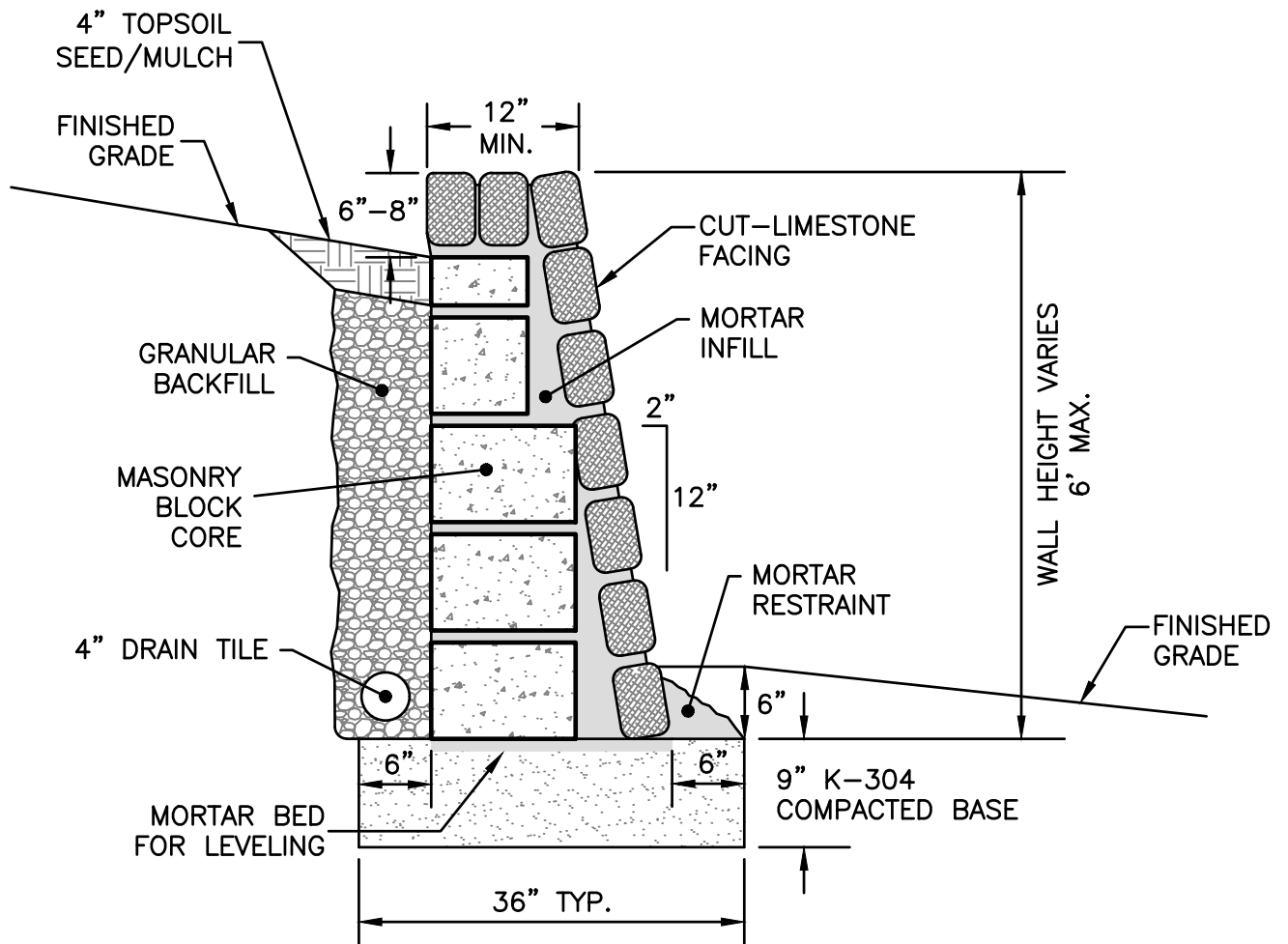
STANDARD DRAWING			K-901 FIRE HYDRANT LOCATION	APPROVAL	
DATE	REVISION	BY		 CITY ENGINEER	
			 <b>City of Kettering</b>	JANUARY 2019	SHEET <b>33</b>

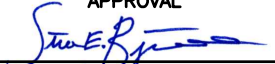

REFERENCE CITY OF KETTERING CONSTRUCTION AND MATERIAL SPECIFICATIONS FOR WALL CONSTRUCTION DETAILS

STANDARD DRAWING			K-911 GRAVITY RETAINING WALL	APPROVAL	
DATE	REVISION	BY		 CITY ENGINEER	
			 <b>City of Kettering</b>	JANUARY 2019	SHEET 34