



**STAFF REPORT
TOWN COUNCIL MEETING
Consent Agenda
March 12, 2013**

TO: HONORABLE MAYOR AND MEMBERS OF THE TOWN COUNCIL
FROM: BRIAN FRAGIAO, DIRECTOR OF PUBLIC WORKS 
DATE: FEBRUARY 28, 2013
SUBJECT: MARETA LANE ROAD IMPROVEMENT PROJECT – ADVERTISE FOR BIDS

RECOMMENDATION:

Approve the Plans and Specifications for the Mareta Lane Road Improvement Project with the findings that the project is exempt under CEQA categories 15301 and authorize Staff to advertise for bids.

ISSUE STATEMENT AND DISCUSSION:

At the December 3, 2012 Town Council meeting, staff presented information regarding the Mareta Lane resident's request to use their Assessment District funds to overlay the street and replace the asphalt curbing with concrete curb & gutter. Currently, the district has roughly \$279,853.

The following scope of work and cost would be required or have been completed:

1. Survey the street for elevations and contouring information (*Completed for \$2,800*)
2. Prepare Plans, Specifications and Estimate (*Completed for \$2,500*)
3. Advertise Project (+/- \$500)
4. Award Project to low bidder (estimated at \$250,000)
5. Inspect Project (+/- \$20,000)

Estimated cost is \$275,800. All cost related to this project would come from the Assessment District funds. The Town does not have any additional funding to contribute to this work. All Town transportation related funds are allocated to Capital Improvement Program projects covering the next five years.

Improvements would include:

1. Rubberized crack sealing
2. Install pavement reinforcing fabric before overlay (+/-46,000 sf)
3. 5 foot edge grind (+/- 3,700 feet)
4. 2 inch Asphalt Overlay (+/- 46,000 sf)
5. Remove existing AC curb and install concrete curb & gutter (+/- 3,700 feet)

6. Remove existing AC sidewalk and install 6 foot concrete sidewalk (optional bid)
7. Repair and/or Replace any damaged landscaping and/or irrigation

The Bid opening is scheduled for April 26, 2013. Once the bids have been received, staff will select the lowest base bid that keeps the cost below the district's funding. Should all bids be higher than the district's funding, staff will discuss with the property owners bid items that could be deleted or delayed for future projects. The project will begin in Late May/ Early June and be completed in 30 days depending on weather and if the sidewalk work is added as part of the project.

A cape seal treatment was applied to Mareta Lane in 2002 and currently is not slated in the five year Capital Improvement Program.

CEQA:

This project is exempt under the California Environmental Quality Act (CEQA) Section 15301. (c&d) (Class 1), "Existing Facilities" of the guidelines.

FINANCIAL AND/OR POLICY IMPLICATIONS:

Funding will come from the Live Oak Estates Community Facilities District No. 4 account that has a current balance of \$279,853. Subtracting the cost of the Surveying (\$2,800) and the Plans, Specifications & Estimate (\$2,500) the balance is \$274,553.00

PLACER COUNTY, CALIFORNIA

Brian Fragiao, Town Engineer
3665 Taylor Road
Loomis, California 95650
Tel.: (916) 652-1840
Fax: (916) 652-1847

CONTRACT BOOK

February 2013

NOTICE INVITING BIDS
DBE/UDBE INFORMATION
PROPOSAL
AGREEMENT
SPECIAL PROVISIONS
AND
TECHNICAL SPECIFICATIONS

PROJECT:

MARETA LANE ROAD IMPROVEMENT PROJECT

FUNDING PROVIDED BY THE LIVE OAK ESTATES SUBDIVISION ASSESSMENT DISTRICT

BIDS OPEN: APRIL 26, 2013 (FRIDAY) @ 3:00 p.m.

Deliver Bids To: Town Offices - Town Clerk's Office
3665 Taylor Road
Loomis, CA 95650

***NOTE* If you choose to mail your Bid Proposal, both the outside and inside envelope **MUST** be clearly marked as [SEALED BID FOR: Mareta Lane Road Improvement Project
DELIVER IMMEDIATELY TO TOWN CLERK'S OFFICE]**

NOTICE INVITING BIDS

Notice is hereby given that the Town Council of the Town of Loomis, State of California, will receive sealed bids at the office of the Town Clerk of said Town, Town Hall, 3665 Taylor Road, Loomis, California 95650, for:

MARETA LANE ROAD IMPROVEMENT PROJECT:

- **Rubberized crack sealing**
- **Paving reinforcing fabric**
- **2 inch Asphalt overlay**
- **Edge grinding**
- **Concrete Curb & Gutter**
- **Driveway Transitions**
- **Repair & Replace Existing Damaged Landscaping and/or Irrigation**
- **Replacing the existing Asphalt sidewalk with a concrete sidewalk**

The Project shall be completed in Thirty (30) days. Said bids to be received up to 3:00 p.m. April 26, 2013 (Friday).

Each bidder must submit a proposal to the Town Clerk on standard forms which are contained in the project specifications. Said proposal to be accompanied by a certified check or bidder's bond of ten percent of the amount of the bid submitted, to be made payable to the Town of Loomis.

Contractor and subcontractors who may be awarded a contract will be required to maintain an affirmative action program, the standards of which are contained in the Standard Specifications. The Town Council of the Town of Loomis reserves the right to reject any or all bids received as the public good may require.

Plans and specifications, to which all prospective bidders are referred, are available in the office of the Town Engineer, Town Hall. A charge of **\$30.00** (sales tax included) will be made for a complete set of plans and specifications, which is nonrefundable. Checks should be made payable to the Town of Loomis.

Notice is hereby given that pursuant to Section 1770, et. seq., of the California Labor Code, the Contractor shall pay not less than the prevailing rate of per diem wages as determined by the Director of California Department of Industrial Relations. Copies of such prevailing rate of per diem wages are on file at the office of the Town Clerk, 6140 Horseshoe Bar Road, Loomis, California 95650, which copies shall be made available to any interested party on request.

The Contractor shall forfeit, as penalty to the Town, twenty-five dollars (\$25.00) for each day or portion thereof, for each workman paid less than the stipulated prevailing rates for any work done under the contract by him or by any subcontractor under him, in violation of the provisions of such Labor Code. The provisions of Section 1775 of said Labor Code shall be complied with.

Notice is also hereby given that all bidders may be required to furnish a sworn statement of their financial responsibility, technical ability and experience before award is made to any particular bidders. Before submitting bids, Contractor shall be licensed in accordance with the provisions of Section 7000 through 7145, inclusive, of the Business and Professions Code of the State of California. The successful Contractor will be required to furnish two acceptable surety bonds; one for faithful performance and the other for labor and materials. Each bond is to be executed in a sum equal to one hundred percent (100%) of the contract price. The successful Contractor will be required to obtain a business license from the City and pay related fees.

A Class "A" or C12 Contractor's License is required to complete this project. No bidder may withdraw his bid for a period of forty-five (45) days after the date set for the opening thereof.

By order of the Town Council of the Town of Loomis dated March 12, 2013.

Brian Fragio, Town Engineer

Proposal

MARETA LANE ROAD IMPROVEMENT PROJECT

The undersigned, as bidder, declares that the only persons or parties interested in this Proposal as principals are those named herein; that this Proposal is made without collusion with any other person, firm or corporation; that he has carefully examined the locale of the proposed work, the proposed form of contract; and he proposes and agrees if this Proposal is accepted that he will contract with the Town, in the form of a copy of the Agreement herein contained; to provide all necessary machinery, tools, apparatus and other means of construction, and to do all the work and furnish all materials specified in the contract, in the manner and time herein prescribed, and according to the requirements of the Town Engineer as therein set forth, and that he will take in full payment therefor, including all applicable State and Federal Taxes and utility connection or service fees, the following prices to wit:

MARETA LANE ROAD IMPROVEMENT					
Base Bid Items					
Item	Description	Units	Estimated Quantity	Item Price	Total
1.	Traffic Control	LS	1	\$	\$
2.	Edge Grinding	LF	3700	\$	\$
3.	2" Type B Asphalt Overlay	SF	46,000	\$	\$
4.	5' Driveway Conforms	EA	37	\$	\$
5.	Thermoplastic Striping and Markings	LS	1	\$	\$
6.	Utility Raising	LS	1	\$	\$
For the Mareta Lane Road Improvement Project, the Lump Sum Price of:			Total Base Bid: \$		

LS - Lump Sum, SF - Square Feet, LF – Lineal Feet, EA - Each

Should additional Assessment District Funds be available after covering the base bid items, the following additional bid item(s) "A" & "B" may be added to the contract. Should the Town decide to add the additional bid item(s), the Town will choose the lowest bid of the total combined cost.

Please note that you are encouraged to bid on all additional bid items that are requested of the property owners. Any bidder that decides not to bid on additional bid items "A" or "B" may be considered non-responsive if the Town decides to select the additional bid item. The Town also reserves the right to reject any and all bids.

MARETA LANE IMPROVEMENTS

TOWN OF LOOMIS, PLACER COUNTY, CALIFORNIA

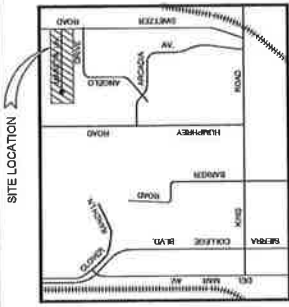

VICINITY MAP

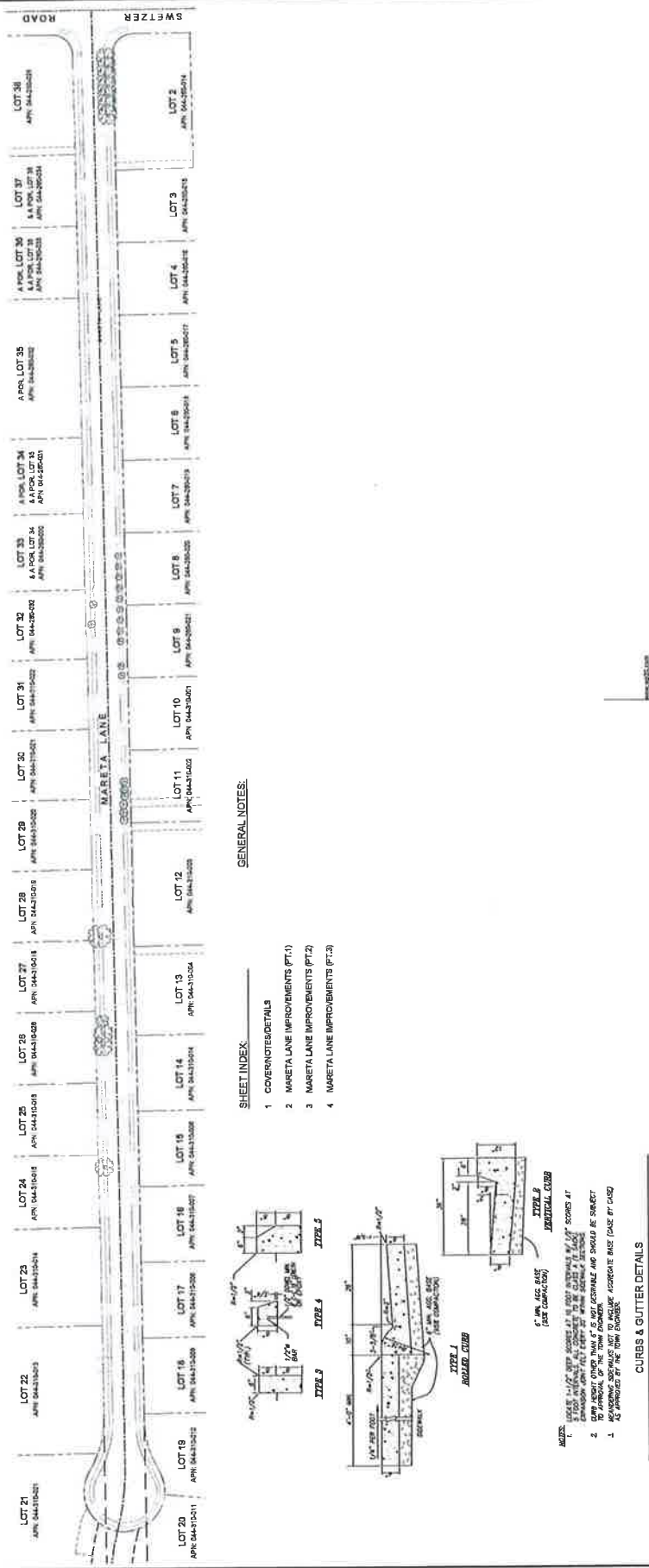

GENERAL NOTES:

- SHEET INDEX:**
- 1 COVER NOTES DETAILS
 - 2 MARETA LANE IMPROVEMENTS (PT.1)
 - 3 MARETA LANE IMPROVEMENTS (PT.2)
 - 4 MARETA LANE IMPROVEMENTS (PT.3)

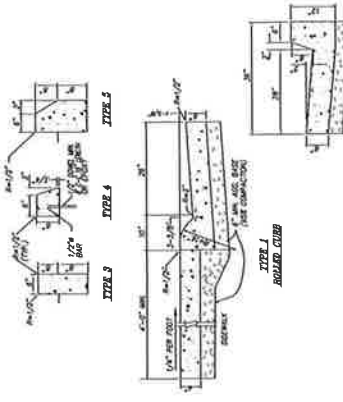

- NOTES:**
- 1. ALL CURB AND GUTTER SHALL BE 6" HIGH UNLESS OTHERWISE NOTED.
 - 2. CURB HEIGHT OTHER THAN 6" SHALL BE ACCURATE AND SHOULD BE SHOWN.
 - 3. ALL CURB AND GUTTER SHALL BE CONCRETE UNLESS OTHERWISE NOTED.
 - 4. ALL CURB AND GUTTER SHALL BE FINISHED TO THE TYPICAL FINISH.

CLIENT: TOWN OF LOOMIS MARETA LANE IMPROVEMENTS TOWN OF LOOMIS PLACER COUNTY, CALIFORNIA COVER SHEET	SHEET NO. <u>1</u> OF <u>4</u> JOB NO. <u>15.032</u>
DA + SGI A Joint Venture 1201 Nevada Blvd., Suite 100 Loomis, CA 95757 (916) 207-1100 www.dasgi.com	
REV. NO. REVISION DESCRIPTION _____ _____ _____ _____	DATE BY _____ _____ _____ _____

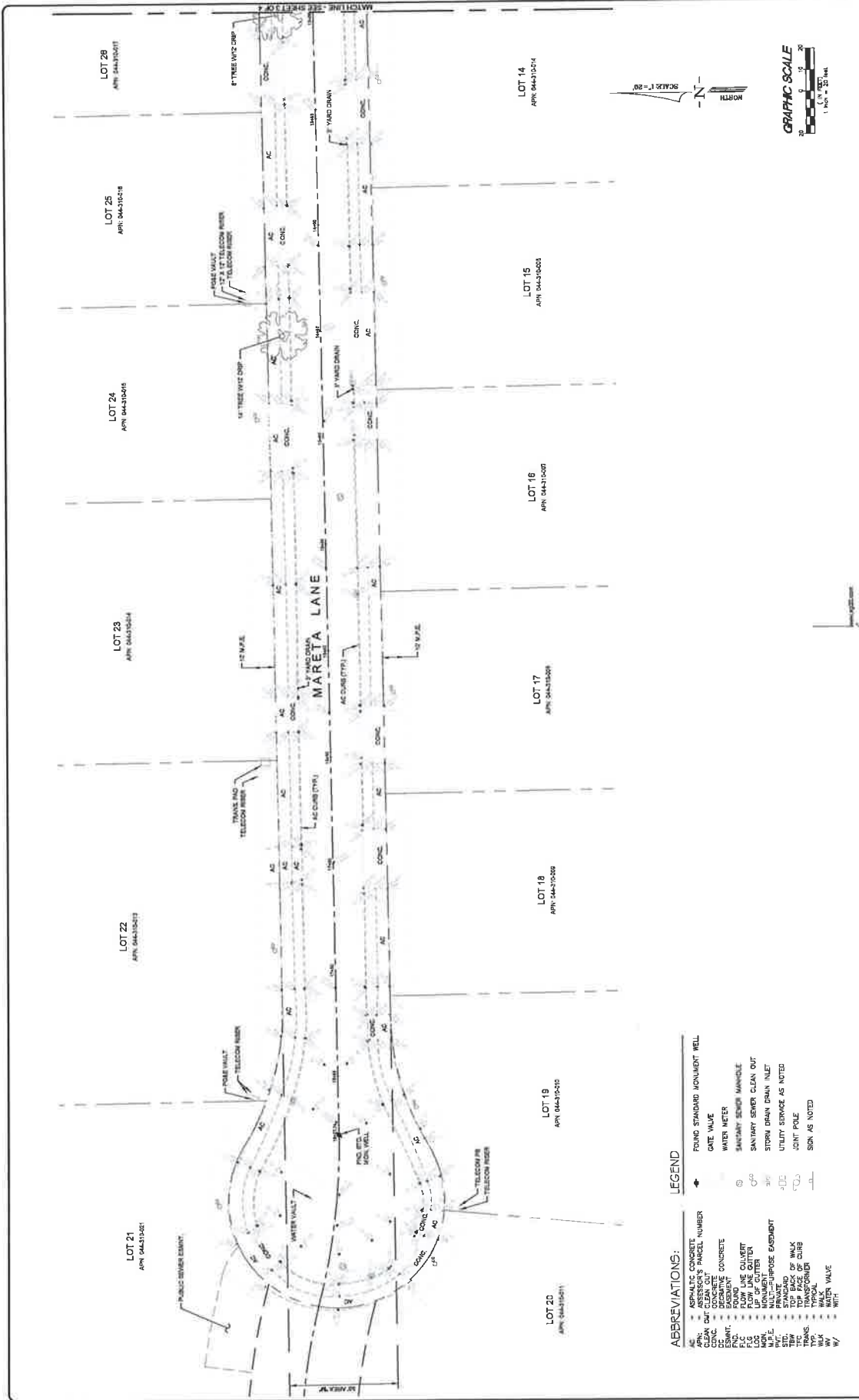

- ABBREVIATIONS:**
- AC ASPHALT CONCRETE
 - CLN CLEAN
 - CONC CONCRETE
 - ESBMT EMBANKMENT
 - F.C. FLOW LINE
 - LOG LOG
 - MON MONUMENT
 - PRV PRIVATE
 - TEW TRENCH
 - TRNG TRUNK
 - TRP TRAP
 - TYP TYPICAL
 - WY WATER
- LEGEND:**
- ◆ FOUND STANDARD MONUMENT WELL
 - ◆ GATE VALVE
 - WATER METER
 - SANITARY SEWER MANHOLE
 - SANITARY SEWER CLEAN OUT
 - STORM DRAIN CLEAN INLET
 - STORM DRAIN INLET
 - UTILITY SERVICE AS NOTED
 - JOINT POLE
 - SIGN AS NOTED

<p>CLIENT: TOWN OF LODMIS MARETA LANE IMPROVEMENTS TOWN OF LODMIS PLACER COUNTY CALIFORNIA GRADING PLAN</p>	<p>SHEET NO. 2 of 4 JOB NO. 15-2513</p>
<p>DESIGNED BY: J. BLAIR CHECKED BY: J. BLAIR DATE: 01-25-2013 SCALE: 1" = 20'</p>	<p>DA + SGI A Joint Venture 101 Sycamore Blvd, Ste 105 Sacramento, CA 95834 Tel: 916.442.1000 Fax: 916.442.1001 www.dasgi.com</p>
<p>REVNO REVISION DESCRIPTION DATE BY</p>	<p>BENCHMARK DESCRIPTION BENCHMARK ELEVATION = 418.88 USGS BENCHM. 418.88 SET IN CONCRETE MONUMENT 100 FT. EAST CROSSING AT KING ROAD, 22' EAST OF EAST TRACK.</p>

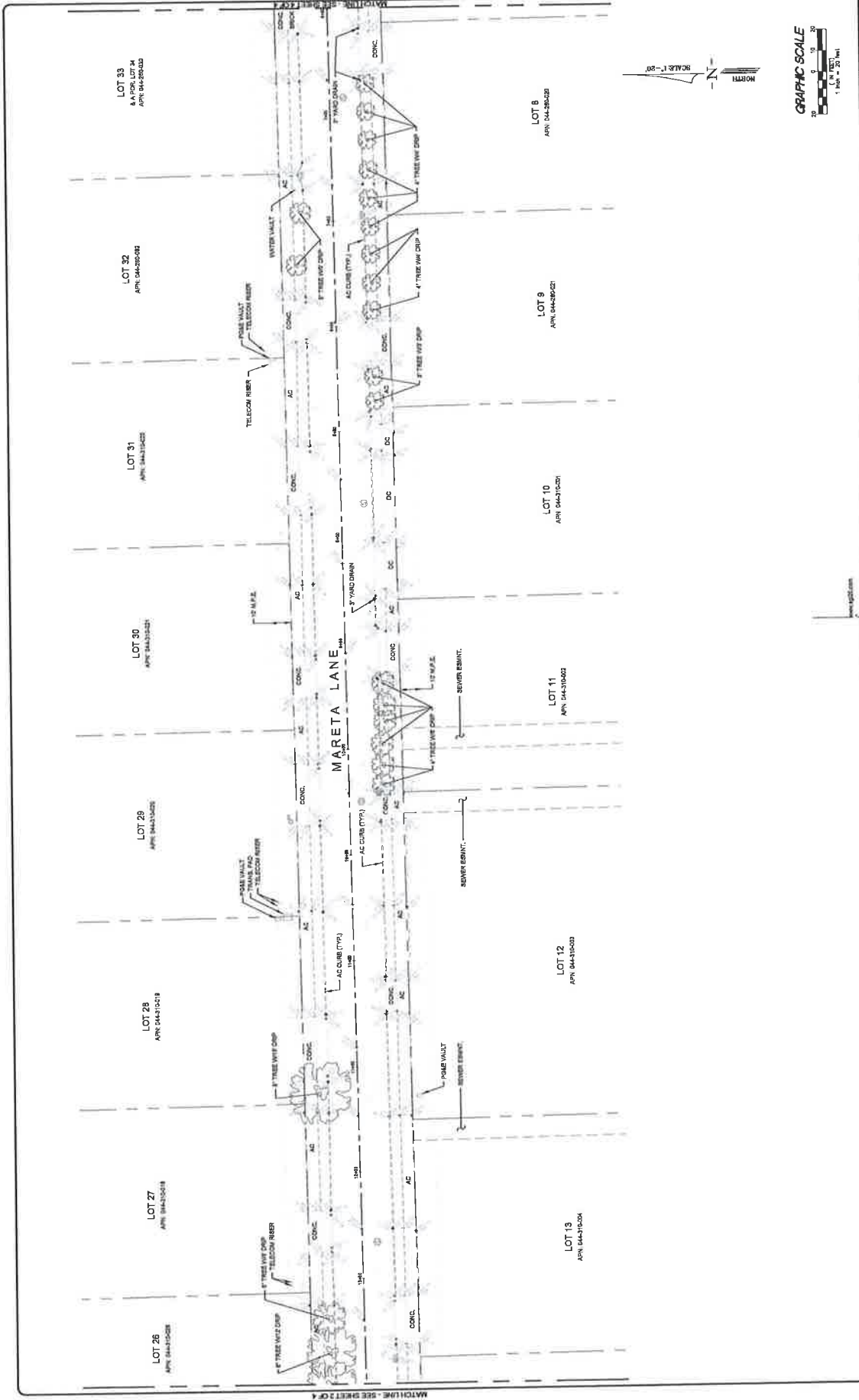

REV. NO. REVISION DESCRIPTION DATE BY _____ _____ _____ _____	DESIGNED T. BAIR DRAWN T. BAIR CHECKED 01/28/2013 DATE 01/28/2013 SCALE 1" = 20'	DA + SGI A Joint Venture 201 Foothill Blvd, Suite 100 Folsom, CA 95630 (916) 434-2000 (Fax) (916) 434-2000 (Cell) www.dasgi.com	CLIENT: TOWN OF LOOMIS MARETALANE IMPROVEMENTS TOWN OF LOOMIS PLACER COUNTY, CALIFORNIA GRADING PLAN	SHEET NO. 3 of 4 JOB NO. TG 1352
	MATCH LINE - SEE SHEET 3 OF 4			

