



December 2021

HIDDEN GROVE

MASSING STANDARDS & ARCHITECTURAL STYLES

TABLE OF CONTENTS

INTRODUCTION	1	SECTION 3: ELEVATIONS	18
SECTION 1: SITE PLAN	2	SINGLE FAMILY ELEVATION DESIGN PRINCIPLES.....	19
SECTION 2: DEVELOPMENT STANDARDS AND MASSING	6	SINGLE FAMILY ELEVATIONS	
ACTIVE AND PASSIVE SIDES.....	12	THE CALIFORNIA RANCH.....	21
DESIGN STANDARDS AND MASSING BY LAND USE.....	13	THE FARMHOUSE REVIVAL.....	25
		THE CRAFTSMAN BUNGALOW.....	29
		THE PRAIRIE.....	33
		THE SPANISH ECLECTIC.....	37
		THE FOURSQUARE REVIVAL.....	41
		THE MONTEREY.....	45
		MULTI-FAMILY ELEVATION DESIGN PRINCIPLES.....	49
		TOWN CENTER COMMERCIAL ELEVATION DESIGN PRINCIPLES.....	50

INTRODUCTION

This document is submitted with the Hidden Grove Tentative Map SB330 Application that was provided to the Town of Loomis in accordance with Government Code Sections 65589.5 and 65941.1. As conceptualized in this document, the Hidden Grove neighborhood will be comprised of a variety of distinct housing types interconnected and tied together by tree-lined walkable streets, open space, and community spaces. By employing a design palette of authentic architectural styles and creative site planning techniques, the neighborhood will embody a strong architectural identity that is consistent with and compliments the surrounding community.

This document is divided into three informational sections. Section 1, “Site Plan,” illustrates the proposed subdivision configuration and defines separate lot types. Section 2, “Development Standards and Massing,” shows setbacks, height limitations, approximate square footage, and other

massing elements that would be applicable to each lot within the proposed subdivision. Section 3, “Elevations,” shows the preliminary design, color, and materials for homes that would be built on each proposed lot. Please note that all standards, elevations and styles shown herein are preliminary and the project’s final standards will be determined during the formal application process.

SECTION 1: SITE PLAN

GENERAL PLAN

The Hidden Grove project is an approximately 61.7+ acre infill site within the Town of Loomis. As illustrated by Figure 1-1, this property is designated by the Loomis General Plan for Town Center Commercial (TC), Residential-Medium Density (RM), Residential-Medium High Density (RMH), Residential- High Density (RH) and Public/Quasi-Public (P) Land Uses.

In order to implement the General Plan, the Hidden Grove project has been designed to provide a mixture of residential housing types, commercial uses, park land, recreational opportunities and open space areas. Figure 1-2 illustrates the proposed land uses for the property while Figure 1-3 is the site plan which depicts the proposed site configuration. Table 1-1 breaks out land uses, approximate acreages and densities for the Plan Area.

FIGURE 1-1: GENERAL PLAN DESIGNATIONS

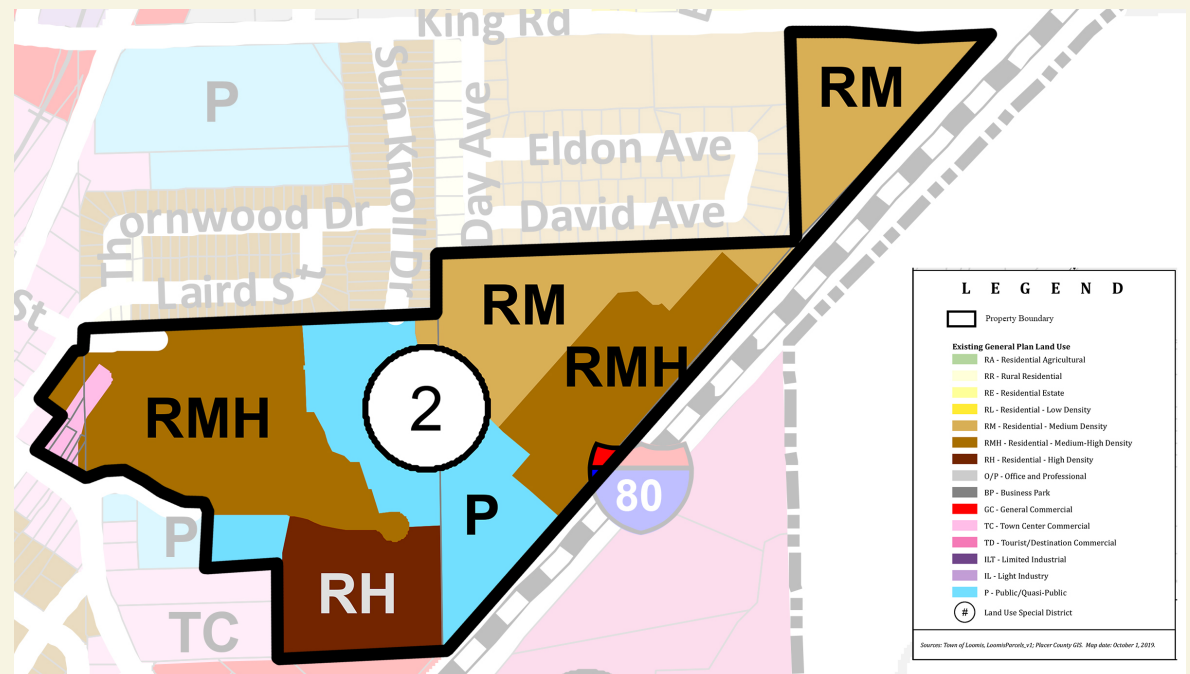

FIGURE 1-2: GENERAL PLAN COMPLIANCE

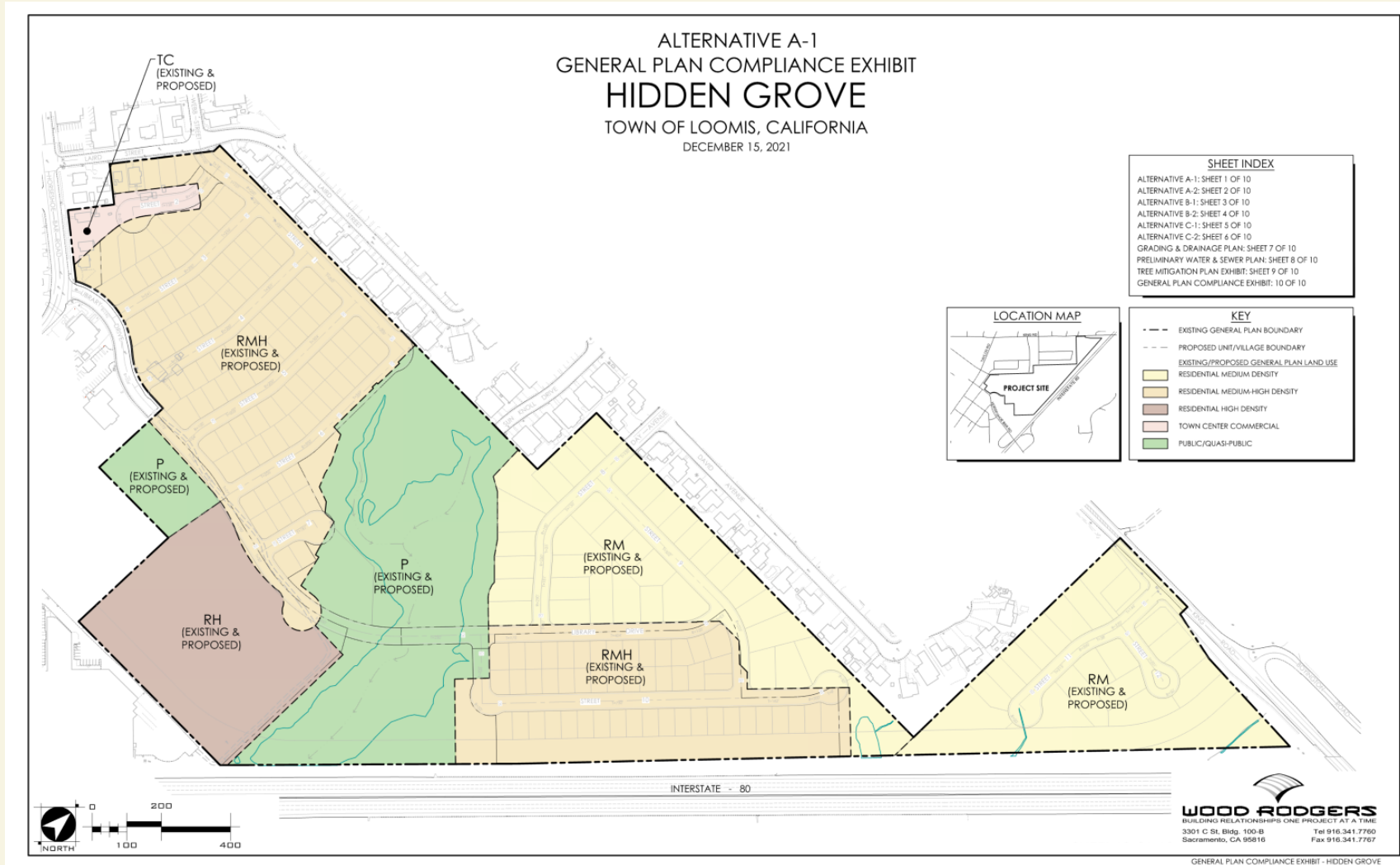

FIGURE 1-3: SITE PLAN



TABLE 1-1: LAND USE SUMMARY

LAND USE SUMMARY								
UNIT/ LOT DESIGNATION	LAND USE	LOT SIZE (TYP)	GENERAL PLAN DESIGNATION	GENERAL PLAN DENSITY	AREA (G)	AREA (N)	DWELLING UNITS	NET DENSITY
UNIT A/VILLAGE 1	MEDIUM-HIGH DENSITY RESIDENTIAL	(47' x 75' TYP)	RMH	(6-10 DU/AC)	13.7	13.3	97	7.3
UNIT B/VILLAGE 2	MEDIUM DENSITY RESIDENTIAL	(65' x 105' TYP)	RM	(2-6 DU/AC)	10.2	9.5	35	3.7
UNIT C/VILLAGE 3	MEDIUM-HIGH DENSITY RESIDENTIAL	(47' x 72' TYP)	RMH	(6-10 DU/AC)	7.9	6.2	50	8.1
UNIT D/VILLAGE 4	MEDIUM DENSITY RESIDENTIAL	(60' x 105' TYP)	RM	(2-6 DU/AC)	8.0	5.2	19	3.7
SUBTOTAL					39.8	34.2	201	
UNIT E/VILLAGE 5	HIGH DENSITY RESIDENTIAL		RH	(10-15 DU/AC)	6.9	5.9	89	15.0
SUBTOTAL					6.9	5.9	89	
LOT A	PARK		PQP		1.5	1.5		
LOT B	OPEN SPACE/RECREATION		PQP		8.1	7.2		
LOT C	OPEN SPACE/RECREATION		PQP		4.3	3.2		
LOT D	TOWN CENTER COMMERCIAL		TCC	(15 DU/AC)(FAR .35-1.6)	1.1	1.0	8	8.0
LOTE	PARK		PQP		0.0	0.9		
LOT F	PARK		PQP		0.0	0.2		
LOTS G-K	LANDSCAPE		PQP		0.0	0.5		
LOTS L-N	OPEN SPACE BASIN		PQP			1.4		
LOTS O-S	BOYINGTON ROAD RESERVATION		RM/RMH/PQP/RH		0.0	5.7		
SUB-TOTAL					15.0	21.6	8	
TOTAL					61.7 AC.	61.7 AC.	298 DU	

*** NOTE: THIS EXHIBIT ACCOMPANIES AN SB 330 APPLICATION.
ALL ACREAGES AND UNIT COUNTS ARE APPROXIMATE AND SUBJECT TO CHANGE WITH FINAL ENGINEERING.**

SECTION 2: DEVELOPMENT STANDARDS AND MASSING

1. MASSING AND ROOF FORM

Proportion and placement of architectural forms and elements must be appropriately and authentically applied in a manner consistent with the historical architectural styles being represented. Roof articulation in the form of proper roof pitches and forms also plays a significant role in the authenticity and diversity of the streetscape and creates an aesthetically pleasing “roof bounce” or skyline effect.

- Massing must be appropriate and authentic to the architectural style (e.g., The Prairie style has a very horizontal character and it would be inappropriate to have dominant vertical massing).
- One out of every three homes must have a significantly different roof form than its neighbors (e.g., forward-facing gable versus side-facing gable).
- Front porches, when appropriate to the building style must have a minimum depth of five (5) feet.

2. REPETITION

Avoiding repetition of identical floor plans or architectural styles is important to create a sense of permanence and the effect of a community that has been built over time.

- The same floor plan with the same architectural elevational style should be no less than five (5) lots away in any direction (on the same side of the street as well as the opposite side of the street).

3. EXTERIOR LOTS TO THE SUBDIVISION

Where appropriate, single-story homes or two story homes with setbacks, buffers or easements will be incorporated along the exterior of the subdivision in conformance with Loomis Town Code Section 13.42.265.

4. FOUR-SIDED ARCHITECTURE

The continuation of style-specific architectural elements from the front facade around to the side and rear elevations creates an authentic architectural statement and is required on all homes within the Hidden Grove Neighborhood. As defined in this document, there is a minimum level of enhancement required on all homes based on architectural style. Each style of architecture has a matrix representing minimum and enhanced elements that are inherent to each style. Blank, unadorned building faces are never permitted; a certain minimum amount of detail is required.

5. COLOR AND MATERIALS

Major Building Forms:

- The primary goal for major building forms is to establish a recognizable neighborhood character which incorporates a rich palette of colors.

Details and Trim:

- Details and Trim: The color of details and trim offers the opportunity to establish individual identity and interest. Detail and trim colors must differ from that of the major building forms and are intended to provide contrast to the primary wall colors.

Materials:

- Primary materials are discussed within each of the seven (7) specific architectural styles.

6. FENCE AND WALL REQUIREMENTS

Fences and walls shall adhere to the following requirements.

Height Limitations:

Within front yard setback:

- Berms, solid wall of fencing shall be a maximum height of 3 ft.

Within side and rear yard setbacks

- Solid wall or fencing shall be a maximum height of 6 ft; berms shall not exceed 3 ft.

Within street side setback:

- Berms, solid wall or fencing shall be a maximum height of 6 ft. Fencing exceeding a height of 4 ft. shall be set back a minimum of 3 ft. from back of sidewalk if sidewalk exists to allow for the planting of landscaping to mitigate the visual impact of the fence mass.

At the intersections of alleys, street, and driveways within sight visibility areas:

- Maximum height shall not exceed 3 ft.

Outside of a required setback:

- As determined by the height limit for structures within the applicable zoning district.

Measurement of Heights:

- Fence height shall be measured as the vertical distance between the finished grade at the base of the fence and the top edge of the fence material.
- The height of fencing atop a wall shall be measured from the base of the wall.
- In cases where elevation of the finished grade within six feet of the base of the fence differs from one side of the fence to the other, the height shall be measured from the side with the lowest natural grade; except that a safety fence with a height of forty-eight inches shall be allowed in all cases.
- Berm heights shall be measured as the vertical distance between the natural grade at the base prior to construction and the top edge of the berm.

7. HEIGHT LIMITS AND EXCEPTIONS

The height of each structure shall not exceed the height limit established for the applicable zoning district except for these notable exceptions:

Exceptions to Height Limits

- Chimneys, cupolas, flag poles, monuments, spires, theater scenery lofts, towers, vents, mechanical equipment screening, water tanks and similar structures.

Height Limit at Street Corners:

Development proposed adjacent to any public or private street or alley intersection shall be designed to provide a traffic safety visibility area for pedestrian and traffic safety.

- Measurement of Visibility Area.** A traffic safety visibility area is a triangle measured as follows, and may include private property and/or public right-of-way. The visibility area shall be defined by measuring 10 feet from the intersection of the extension of the front and street side curb lines (or the right-of-way lines where there is no curb) and connecting the lines across the property.

- Height Limit.** No structure, sign or landscape element shall exceed thirty-six inches in height within the traffic safety visibility area, unless approved by the public works director, except for trees with their canopy trimmed to a minimum of eight feet above grade

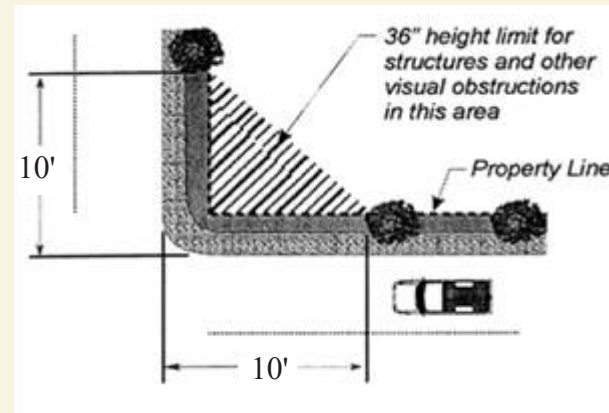

Required Traffic Safety
Visibility Area

8. DRIVEWAYS

Each driveway providing site access from a street, alley or other public right-of-way shall be designed, constructed and maintained as follows:

Number of Driveways.

- Multifamily and Nonresidential Projects. A multifamily or nonresidential project on a parcel of two acres or less shall be limited to a maximum of two driveways, unless the director and town engineer determine that more than two driveways are required to accommodate the traffic for the project. Whenever a property has access to more than one street, access shall be generally limited to the lowest volume street where the impact of a new access will be minimized.
- Single-Family Dwellings and Duplexes. A single-family dwelling or duplex shall be allowed one driveway. A circular driveway may be allowed on a parcel with seventy feet or more of street frontage.

Distance from Street Corners.

Each driveway shall be located a minimum of 45' feet from the nearest intersection, as measured from the centerline of the driveway to the centerline of the nearest travel lane of the intersecting street.

Driveway Spacing.

Driveways shall be separated along the street frontage as follows:

- **Single-family and Duplex Residential Development.** Driveways shall be separated by at least six feet, unless a shared, single driveway is approved by the director. The six-foot separation does not include the transition or wing sections on each side of the driveway; and
- **Multifamily and Nonresidential Development.** Where two or more driveways serve the same or adjacent multifamily or nonresidential development, the centerline of the driveways shall be separated by a minimum of fifty feet. Exceptions to this standard shall be subject to the approval of the town engineer.

Driveway Width and Length.

- **Single-Family Dwellings.** Each single-family dwelling shall be provided a driveway with a minimum length of twenty feet from the back of the sidewalk, or the edge of the right-of-way where there is no sidewalk.

ACTIVE AND PASSIVE SIDES

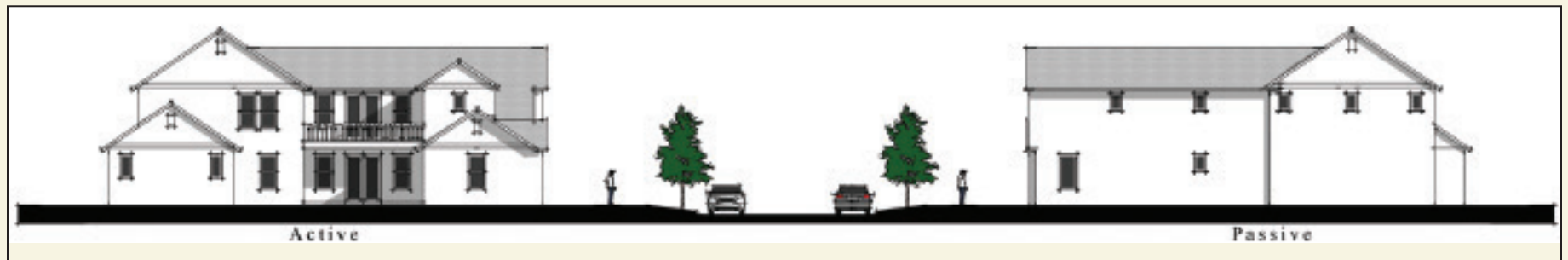

Active and Passive Sides

ACTIVE AND PASSIVE SIDES

Side yards offer a unique opportunity for private outdoor space that can be easily overlooked when not planned effectively. To promote the utilization of these spaces, it is important to designate active and passive sides to each home. The active side of a home is identified as having more and larger windows and the most usable outdoor living space. The passive side of the house has fewer and smaller windows to promote privacy for the neighbor's active side. This creates a relationship between homes and helps create an enhanced living environment.

Active and passive sides must be adjacent to each other to ensure privacy for the active side.

Reciprocal use easements are encouraged when utilizing passive and active sides to allow for more usable side yard area.

For side drive or pushback garage lots, the wall adjacent to the side drive must be active.

DESIGN STANDARDS AND MASSING

UNIT A / VILLAGE 1 & UNIT C / VILLAGE 3

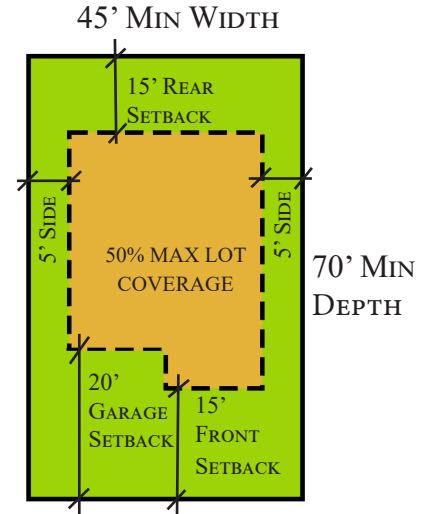
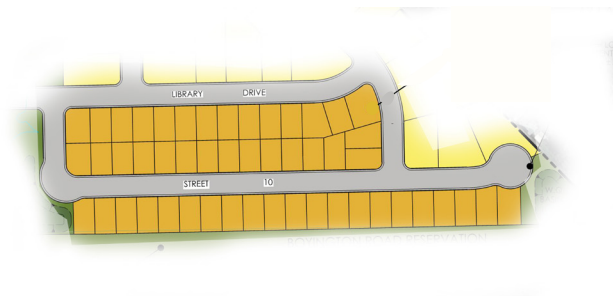

Lot Characteristics	Minimum Lot Size	3,150 s.f.	Garage Setbacks	Side	5'
	Width (Min.)	45'		Rear	5'
	Depth (Min.)	70'		Minimum Driveway Length	20'
	Maximum Lot Coverage	60%			
Principal Building Setbacks (Min.)	Front	15'	Approximate Building Size Range	1,400 - 3,600 s.f.	
	Side	5'			
	Corner Lot Side Yard Along Street	12.5'	Maximum Building Height	30' / 2 stories	
	Rear (to Living Space)	15'			

Notes:
 (1) All setbacks are minimum unless otherwise specified.
 (2) Building square footages are approximate and will vary based upon final lot size and configuration.

DESIGN STANDARDS AND MASSING

UNIT B / VILLAGE 2

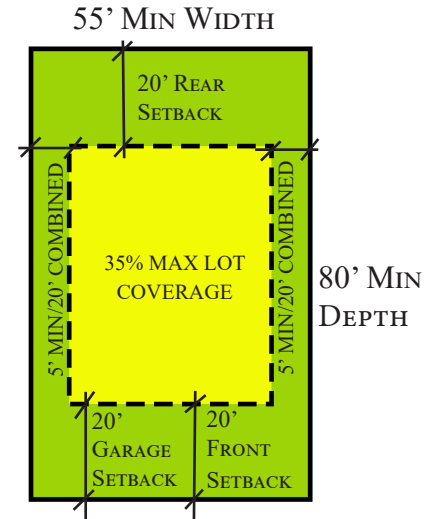
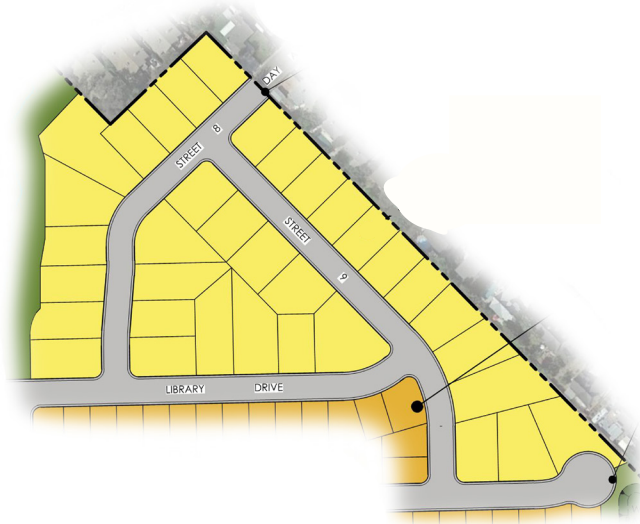

Lot Characteristics	Minimum Lot Size	5,000 s.f.	Garage Setbacks	Side	5'
	Width (Min.)	55'		Rear	5'
	Depth (Min.)	80'		Minimum Driveway Length	20'
	Maximum Lot Coverage	35%		Approximate Building Size Range	1,500 - 3,600 s.f.
Principal Building Setbacks (Min.)	Front	20'	Maximum Building Height		30'/2 stories
	Side (A total of 20' combined for both interior sides, minimum 5' each side)	5' (Min.)			
	Corner Lot Side Yard Along Street	20'*			
	Rear (to Living Space)	20'			

* In instances where the corner side yard setback applies, the interior yard setback is a 5' minimum.

Notes:
 (1) All setbacks are minimum unless otherwise specified.
 (2) Building square footages are approximate and will vary based upon final lot size and configuration.

DESIGN STANDARDS AND MASSING

UNIT D / VILLAGE 4

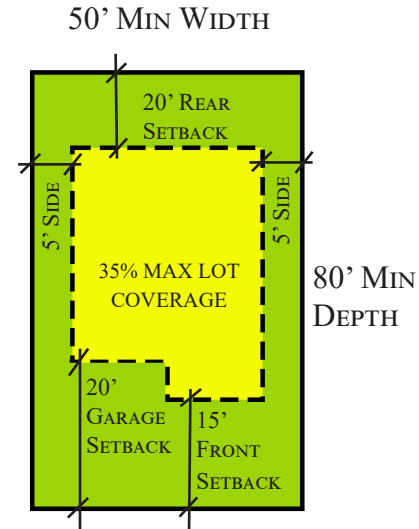

Lot Characteristics	Minimum Lot Size	4,000 s.f.	Garage Setbacks	Side	5'
	Width (Min.)	50'		Rear	5'
	Depth (Min.)	80'		Minimum Driveway Length	20'
	Maximum Lot Coverage	50%		Approximate Building Size Range	1,500 - 3,600 s.f.
Principal Building Setbacks (Min.)	Front	15'	Maximum Building Height	30'/2 stories	
	Side	5'			
	Corner Lot Side Yard Along Street	12.5'			
	Rear (to Living Space)	20'			

Notes:
 (1) All setbacks are minimum unless otherwise specified.
 (2) Building square footages are approximate and will vary based upon final lot size and configuration.

DESIGN STANDARDS AND MASSING

UNIT E / VILLAGE 5

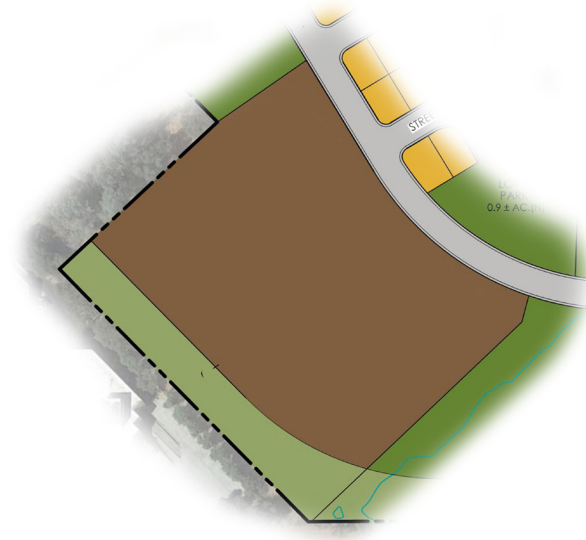

Minimum lot size ^{(1) (2)}	
Area (net)	1,500 sf ⁽¹⁾
Width, depth	25 ft
Depth	60 ft
Residential density ^{(1) (2)}	
Max. Density	10-15 units/acre
Setbacks ⁽¹⁾	
Front ⁽¹⁾	15'
Side-Interior (Each) ⁽¹⁾	5' for detached units; attached clusters and zero lot line are permitted
Side-Corner ⁽¹⁾	12.5 ft
Rear ⁽¹⁾	10 ft

Lot coverage ⁽¹⁾	60%
Height limit ⁽¹⁾	
Maximum height	30 ft. and 2 stories
Landscaping ⁽¹⁾	Per Chapter 13.34 in Zoning Code
Parking ⁽¹⁾	Per Chapter 13.36 in Zoning Code
Signs ⁽¹⁾	Per Chapter 13.38 in Zoning Code

Notes:

(1) The Residential-High Density Overlay established by Ordinance 254 allows up to 7 acres of 20-25 units per acre on the project site for the development of a minimum of 129 very low and low income units “by right”. Should the developer elect to implement the RH-20 Overlay, development standards will differ than those shown here and will be determined on a project specific basis in order to achieve the goal of meeting affordable housing requirements. Should the developer elect to proceed without the benefit of the RH-20 overlay, the development standards shown here will apply consistent with the Residential-High Density (RH) land use designation of the Loomis General Plan.

(2) A condominium, townhome, or planned development project may be subdivided with smaller parcels for ownership purposes, with their minimum lot area determined through the subdivision review process, provided that the total number of dwellings does not exceed the maximum density allowed by the applicable zoning district.

DESIGN STANDARDS & MASSING

TOWN CENTER COMMERCIAL



Minimum lot size	
Area (net)	5,000 sf ⁽¹⁾
Width, depth	Determined by the review authority through the subdivision process
Residential density	
Max. Density	15 units/acre in a mixed use project
Setbacks	
Front	Horseshoe Bar Road - 15' for landscaping and the preservation of existing buildings and landscaping, Other streets - 15'
Side-Interior (Each)	15' along a property line abutting a residential zone or use, not required otherwise
Side-Corner	Same as front setback
Rear	Same as interior side setback

Floor area ratio (FAR)	0.25 min., 1.60 max.	More than 0.60 may be approved where parking is provided in a structure
Lot coverage	35% to 60%	
Height limit		
Maximum height	35' - 3 stories	
Landscaping	Per Chapter 13.34 in Zoning Code	
Parking	Per Chapter 13.36 in Zoning Code	
Signs	Per Chapter 13.38 in Zoning Code	

Notes:
 (1) A commercial condominium, or a residential condominium, townhome, or planned development project may be subdivided with smaller parcels for ownership purposes, with the minimum lot area requirement determined through the subdivision review process, provided that the overall development site complies with the lot area requirements, and the total number of any dwellings is in compliance with the maximum density established by the applicable zoning district.

SECTION 3: ELEVATIONS

The concept, inspiration, and vision for the Hidden Grove Neighborhood are based on a unique and compelling design character derived from timeless, small town neighborhoods. The architectural styles presented herein include the most prevalent historical architectural styles of these town neighborhoods (listed to the right) and are representative of the styles envisioned within the Hidden Grove Neighborhood.

When interspersed throughout the neighborhoods, this collection of architectural elevations will create a diverse and eclectic streetscape through massing and form, material and color, and detailing. The variety of styles will energize and animate the streetscape, creating a dynamic and vibrant complement to the surrounding neighborhood.

The following architectural elevations define the history and intent of each style, identify key style elements, and provide a matrix that identifies the minimum elements required for each style along with applicable enhanced elements. Additionally, sketches of primary style elements and details and pictorial examples of both a historic and present day version of the style are represented. With the intent of creating authentic representations of these architectural styles, all of the minimum elements outlined on the style specific matrix are required along with three enhanced elements.

THE CALIFORNIA RANCH
THE FARMHOUSE REVIVAL
THE CRAFTSMAN BUNGALOW
THE PRAIRIE
THE SPANISH ECLECTIC
THE FOURSQUARE REVIVAL
THE MONTEREY

SINGLE FAMILY ELEVATION DESIGN PRINCIPLES

To further define the architecture of the Hidden Grove Neighborhood, the following statements apply to all styles herein:

- On styles utilizing stucco, smooth, imperfect smooth, or fine sand finish stucco is the only allowed finish (further defined per style on pages to follow).
- Masonry must be applied authentically, wrapping outside corners and terminating at inside corners.
- All material changes must occur on an inside corner.
- No fascia gutter.
- No concrete rake tiles.
- Garage doors and entry doors shall complement architectural style.
- Lights should complement architectural style.
- Homes built in the Hidden Grove Neighborhood shall utilize high quality windows that enhance the selected architectural style of each home. Vinyl windows are not allowed. Windows shall be either wood or clad wood with the ability to choose frame colors that coordinate with the architecture and the chosen color scheme. Muntins, when used, shall be of high quality and mimic “true divided light” windows. Muntins that are internal to the windowpanes without exterior detailing are discouraged.
- When shutters are used, each shutter must be sized to one-half of entire adjacent window width.

Each elevation section within this document is broken into four pages, each with a distinct purpose. The first page articulates the history of the architectural style as well as the intent of that style within the Hidden Grove Neighborhood. Additionally, this page offers a list of some of the elements that make the defined style distinctive. These elements draw from both the minimum and enhanced elements from the matrix found on the following page and are intended to be descriptive, rather than prescriptive, by conveying the essence of the style. The second page offers a matrix of the minimum and enhanced elements of each style and serves as the prescriptive requirements of the style. The third page graphically represents a selection of the key style elements described in the matrix. Finally, the last page offers details and vignettes as well as pictorial representations, both historical and present day, of well-executed examples of the style.

THE CALIFORNIA RANCH

HISTORY AND INTENT

When construction resumed after World War II, houses based on historical precedent were largely abandoned in favor of new variations of the modern styles that had only begun to flourish in the pre-war years. The earliest of these, the Minimal Traditional style, was a simplified form loosely based on the previously dominant Tudor style of the 1920s and 1930s. By the early 1950s, they were being replaced by the

Ranch style, which dominated American domestic building through the '60s.

The California Ranch style of the Hidden Grove Neighborhood is a modern interpretation that blends the essence of the Minimal Traditional and Ranch styles to create a new style intended to emphasize the eclectic and distinctive nature of the community.



Distinctive Style Elements

- | | |
|---|-------------------------|
| 1 | Clinker Brick Chimney |
| 2 | Shake Roof |
| 3 | Shed Roof at Front Door |
| 4 | Board & Batten Siding |
| 5 | Painted Brick |

THE CALIFORNIA RANCH

Style Elements	Minimum Elements	Enhanced Elements ¹
Form	<ul style="list-style-type: none"> • Single story. • Symmetrical or asymmetrical form. • Dominant front gable or side-gabled. • Small covered entry porch. 	<ul style="list-style-type: none"> • Full hipped roof. • Screened side or rear porch.
Roof	<ul style="list-style-type: none"> • Low pitched roof (4:12-6:12). • Composition shingle or flat concrete tile with a shake appearance. • Tight gable overhangs (4" max) with slender, understated fascias (4" max). • Eave overhangs can be moderate (12" max) with a thin, crisp fascia line. 	<ul style="list-style-type: none"> • Gable dormers.
Walls	<ul style="list-style-type: none"> • Predominantly lap siding. • Siding exposure can range from very tight to wide (3"-10"). 	<ul style="list-style-type: none"> • Brick or stone wall cladding as principal wall material with lap siding at gable ends. • Use of a variety of wall materials is common to accent different vertical units.
Windows & Doors	<ul style="list-style-type: none"> • Gridded windows with simple wood trim on all four sides. • Rectangular windows can be vertically or horizontally-oriented. • Simple wood entry door. 	<ul style="list-style-type: none"> • Decorative shutters. • Feature picture window at front elevation. • Large square gridded window at front elevation. • Front feature windows grouped into three, with a large square central window between two vertically-oriented single hung windows. • Accent colored window frames.
Details	<ul style="list-style-type: none"> • Covered entry porch integrated into the primary roof or as an independent element. • Decorative wood spindles or wrought iron porch supports. 	<ul style="list-style-type: none"> • Massive rectangular brick chimney, often painted. • Colonial-influenced octagonal or round gable end vent painted to match siding. • Porch integrated into primary roof with brick porch supports (when primary wall cladding is brick).

¹ Minimum three enhanced elements per house are required.

² All corner lots must employ at least four enhancements from the enhanced elements list on all street-adjacent building faces (in addition to the minimum enhancements required for all homes).

THE CALIFORNIA RANCH

FORWARD
GABLE

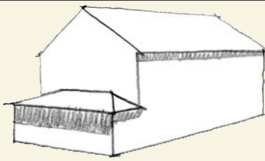

SIDE
GABLE

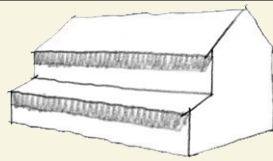

ASSYMETRICAL
GABLE

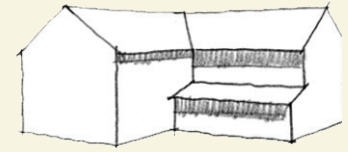

Entry Doors
and
Surrounds

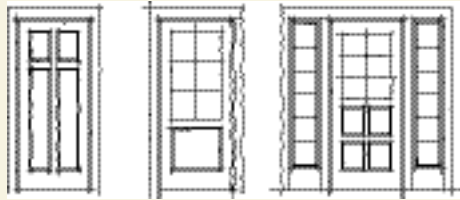

Window
Patterns

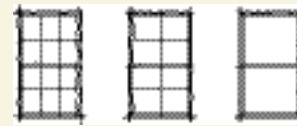

Window
Groupings

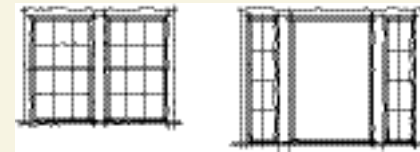

Garage
Doors



Window
Surrounds

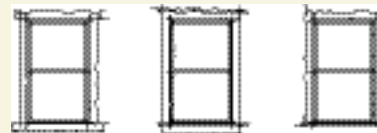

Porch
Columns

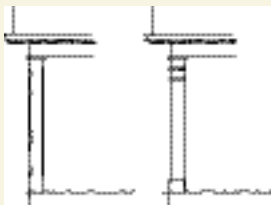

Chimneys

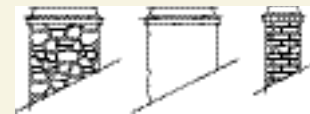

Shutters

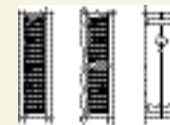

THE CALIFORNIA RANCH

DETAILS

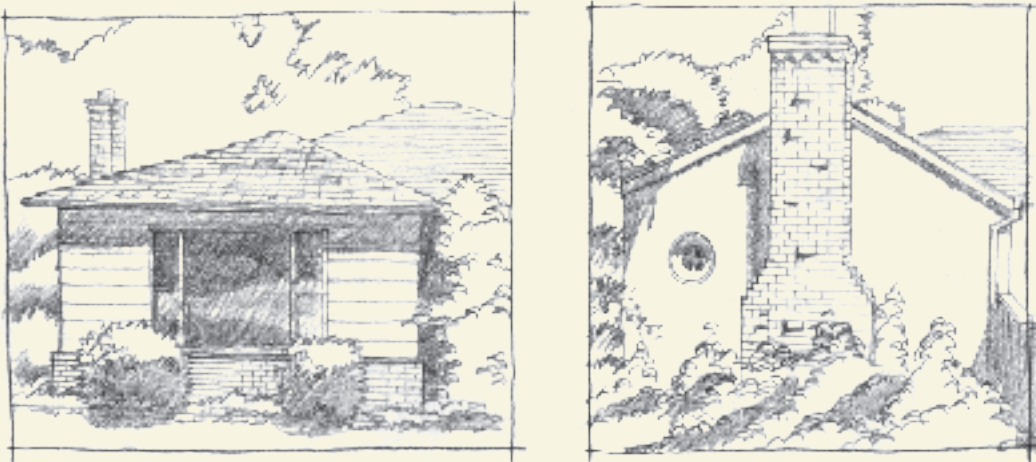

PICTORIAL EXAMPLES



Historical Representation



Present Day Interpretation

THE FARMHOUSE REVIVAL

HISTORY AND INTENT

In the Sacramento area, farmhouses were utilitarian housing for farmers settling in outlying areas of the region. They were typically wood frame with clapboard siding. These homes were simply detailed and understated, and often evolved in size and form to reflect the success and size of the farming family. Although utilitarian in nature, the farmhouse also reflected the regional style of the time to the extent possible, sometimes emulating a higher style of architecture by borrowing details of widely accepted styles.

The intent of the Farmhouse Revival at the Hidden Grove Neighborhood is to include a style that embraces the agrarian history of the region. The Farmhouse Revival is a traditional, honest representation of the style with simple forms and detailing, lacking the highly stylized features of its Midwestern and East Coast counterparts.

Distinctive Style Elements

- | | |
|---|---------------------------------|
| 1 | Slender Porch Columns |
| 2 | Projecting Porch with Shed Roof |
| 3 | Rectangular, Cross Gabled Form |
| 4 | Dominant Gable Roof |
| 5 | Lap Siding |
| 6 | Brick Chimney |
| 7 | Single-Hung Windows |
| 8 | Louvered Shutters |

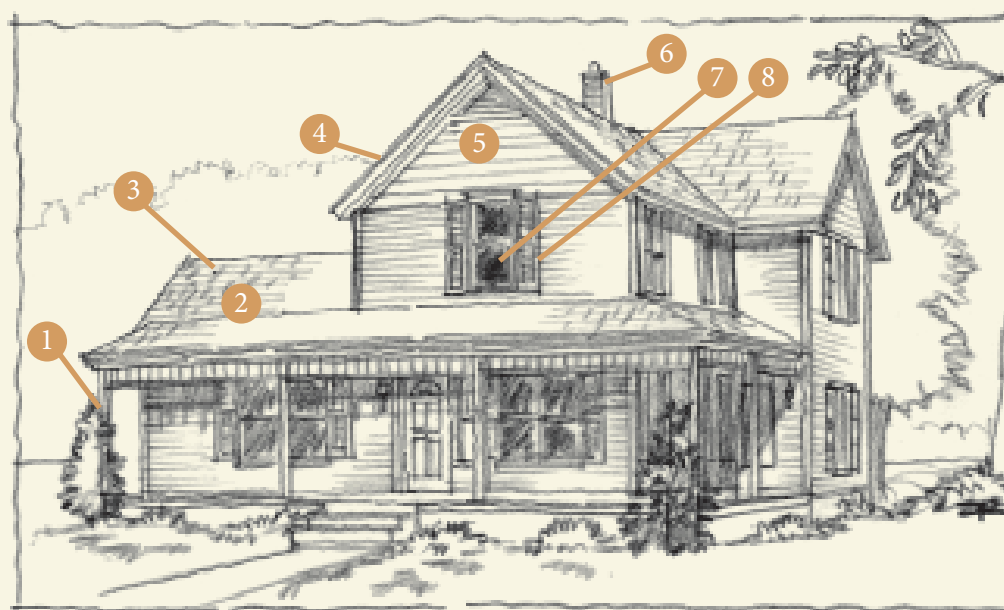

Style Elements	Minimum Elements	Enhanced Elements ¹
Form	<ul style="list-style-type: none"> • Rectangular, typically two-story. • Front, side, or cross-gabled. • Symmetrical or asymmetrical. • Entry porch, very simple in form and detailing. • Porches project from the house rather than being incorporated into the primary massing 	<ul style="list-style-type: none"> • Two-story with opposing wings in larger homes. • One- or two-story wings and covered porches. • Form may reflect additions to original house. • Covered porches along entire façade or wrapping around corners, very simple in form and detailing.
Roof	<ul style="list-style-type: none"> • Dominate gable roof forms. • Roof pitch 6:12 to 10:12 with porches of lower profiles. • 6” to 12” overhangs. • Concrete shingles that are flat or resemble wood shake or composition asphalt shingles. • Tight wood fascias and rakes. 	<ul style="list-style-type: none"> • Shed roof forms, reflecting additions to the original house. • Porch roofs or entire roofs of standing seam metal. • Roof dormers, shed or gabled, symmetrically organized. • Fascias and rakes may be box end soffit or open with exposed rafters and starter board.
Walls	<ul style="list-style-type: none"> • Primary exterior material is lap siding with 6”-8” exposure. • Window and door trim, corner boards, starter boards, and vergeboards used as siding terminations. 	<ul style="list-style-type: none"> • Lap siding with tighter exposure or shingles at accent areas. • Picket railings at porches in various styles. • Stone at raised foundation. • Accent colored window frames.
Windows & Doors	<ul style="list-style-type: none"> • Wood window and door trims. • Single hung vertical windows with or without window grids. 	<ul style="list-style-type: none"> • Enhanced (built-up) window trim.
Details	<ul style="list-style-type: none"> • Verge rafters. • Trim at corner boards, verge boards, and starter boards. • Slender, unornamented square or round porch columns. 	<ul style="list-style-type: none"> • Roof ornamentation such as cupolas, weather vanes, or dovecote accents. • Chimneys clad in stone, brick, or siding with basic rectilinear termination caps.

¹ Minimum three enhanced elements per house are required.

² All corner lots must employ at least four enhancements from the enhanced elements list on all street-adjacent building faces (in addition to the minimum enhancements required for all homes).

THE FARMHOUSE REVIVAL

FORWARD
GABLE

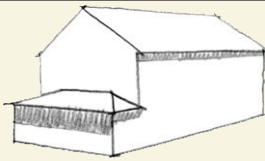

SIDE
GABLE

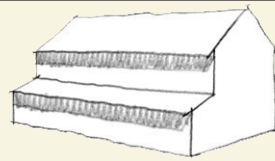

ASSYMETRICAL
GABLE

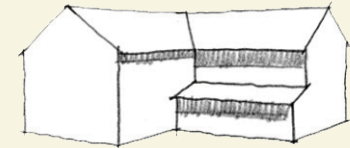

Entry Doors
and
Surrounds

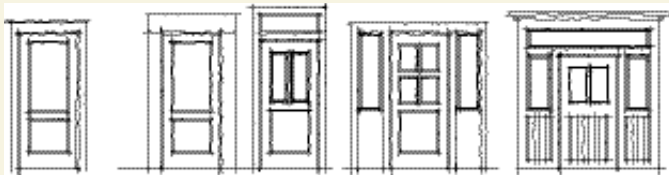

Window
Patterns

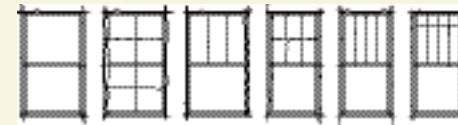

Garage
Doors

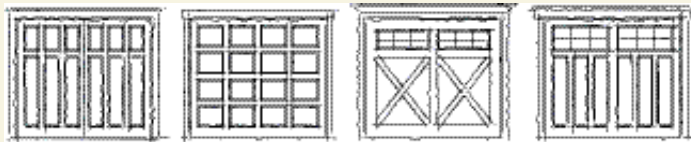

Window
Groupings

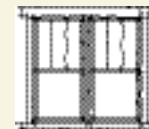

Window
Surrounds

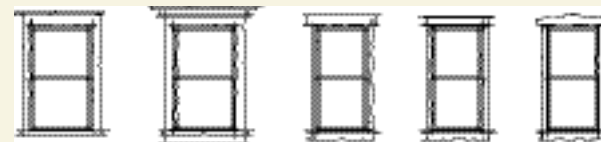

Porch
Columns

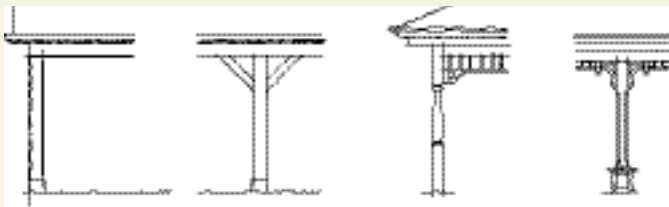

Shutters



THE FARMHOUSE REVIVAL

DETAILS

PICTORIAL EXAMPLES

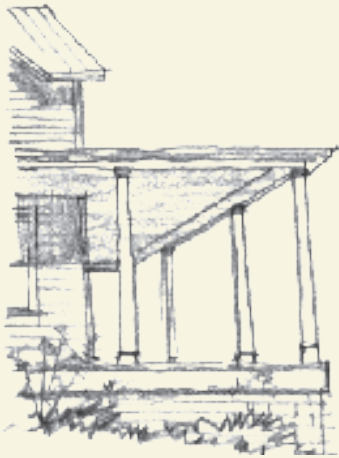

Raised Porch

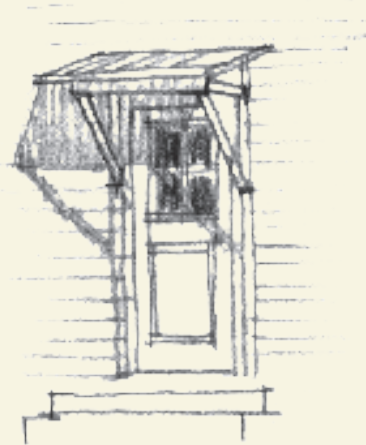

Shed Roof at Door



Gable and Porch



Historical Representation



Present Day Interpretation

THE CRAFTSMAN BUNGALOW

HISTORY AND INTENT

The Arts and Crafts bungalow was an enormously influential form and style of architecture in Sacramento between 1906 and 1918, the first truly American vernacular style. The bungalow broke with earlier formal Victorian spatial arrangements and changed the way that families lived in and related to

their houses. Architecturally, the Craftsman bungalow was designed to achieve harmony between the house and its lawn and garden, to get as close as possible to nature. A Craftsman bungalow has many of the hallmarks of the Arts and Crafts aesthetic: clinker brick, carved rafter tails, a mixture of

cladding (brick, clapboard, tile and shingle), and oversized eave brackets painted in colors of nature.

The intent of the Hidden Grove Neighborhood's Park Bungalow recalls the comfortable and welcoming nature of the Craftsman bungalows found in the towns across America in the early 20th Century. These homes reflect a sense of permanence that only artisanship and careful design can convey.

Distinctive Style Elements

- | | |
|----|----------------------------|
| 1 | Deep Recessed Porch |
| 2 | Wide Entry Door |
| 3 | Shingle Siding |
| 4 | Gable Roof |
| 5 | Gable Ornamentation |
| 6 | Gable Vents |
| 7 | Decorative Window Patterns |
| 8 | Knee Braces |
| 9 | Wide Overhangs |
| 10 | Decorative Porch Columns |
| 11 | Masonry Column Base |

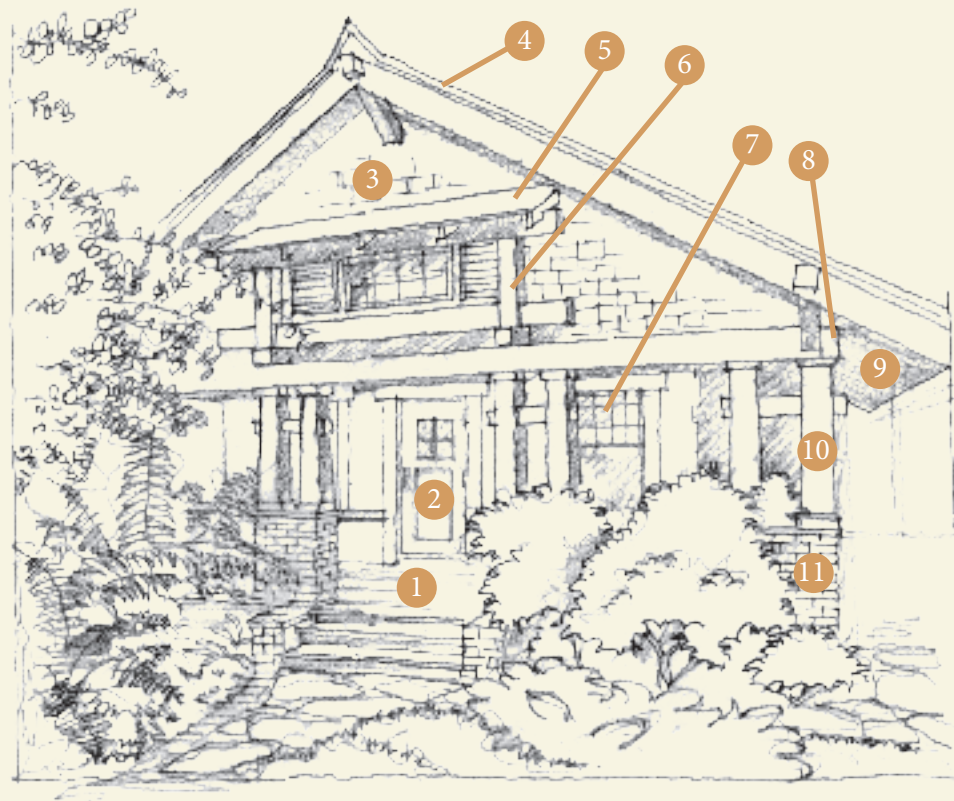

THE CRAFTSMAN BUNGALOW

Style Elements	Minimum Elements	Enhanced Elements ¹
Form	<ul style="list-style-type: none"> • Simple massing on one to one-and-a-half stories, front or side gabled. • Symmetrical or asymmetrical form. • Deep front entry porch. • Stylized column and beam detailing at porches 	<ul style="list-style-type: none"> • Cross-gabled massing. • Two stories with a combination of one and two-story elements. • Full width, deep porch at entry.
Roof	<ul style="list-style-type: none"> • Low-pitched roofs with large over-hanging eaves, emphasizing horizontal planes. • 4:12 to 6:12 roof pitch. • 16” to 24” overhangs. • Flat concrete tile with a shingle appearance or composition shingle. 	<ul style="list-style-type: none"> • Varied porch roofs; shed or gabled. • Cascading (multiple) gables. • Roof dormers (shed or gable form). • 24” to 36” overhangs. • Extended and shaped barge rafters. • Exposed rafter tails at eaves.
Walls	<ul style="list-style-type: none"> • Exterior wall materials with combinations of wood shingles, horizontal siding, board and batten, and stucco. • Foundation or wainscot using stone or brick. 	<ul style="list-style-type: none"> • Stone, brick or combination chimneys. • Eliminate stucco as a wall treatment. • Battered (tapered) stone foundation or wainscot
Windows & Doors	<ul style="list-style-type: none"> • Single hung windows at front elevations. • Divided light windows with wood trim. • Use windows individually or in groups (typically two or three). • Doors with full surrounds. • Windows with full surrounds and a projected sill/apron. 	<ul style="list-style-type: none"> • Casement windows. • Three or more windows in a “ribbon.” • Grouped windows with a high transom. • Wide wood entry door with integrated glass. • Wood door and window surrounds. • Accent colored window frames.
Details	<ul style="list-style-type: none"> • Entry porches with columns resting on larger pier or bases. • Porch rails of repeated vertical elements. • Wood brackets or knee braces. • Surface mounted fixtures on front elevations must complement architectural style. • Garage door patterns and lights to complement the architectural style. 	<ul style="list-style-type: none"> • Entry porch columns consist of single or multiple wood posts with battered brick or stone pier or base. • Porch rails comprised of decoratively cut boards that create a pattern. • Additional “stick-work” in gable ends. • Typical downspouts replaced with “rain chains.” • Open eave overhangs with shaped rafter tails. • Decorative ridge beams, outlookers and purlins. • Porte-cochère, pergola, or trellis that continues, or is integrated with, the front porch.

¹ Minimum three enhanced elements per house are required.

² All corner lots must employ at least four enhancements from the enhanced elements list on all street-adjacent building faces (in addition to the minimum enhancements required for all homes).

THE CRAFTSMAN BUNGALOW

FORWARD
GABLE

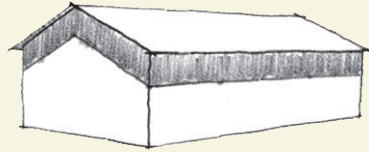

SIDE
GABLE



CROSS
GABLE

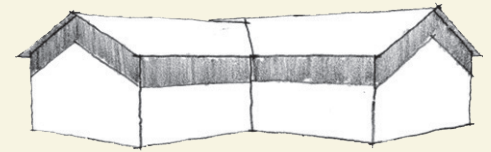

Entry Doors
and
Surrounds

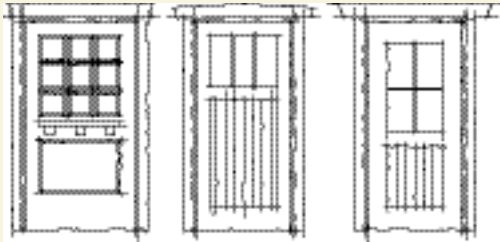

Window
Patterns

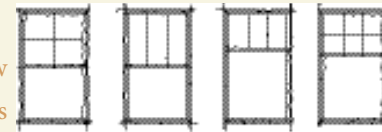

Garage
Doors

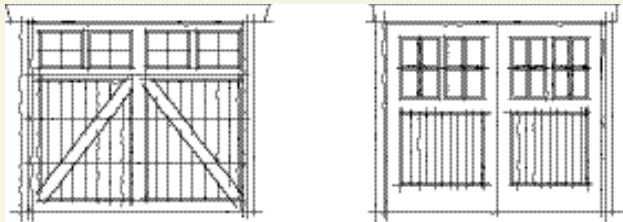

Window
Groupings

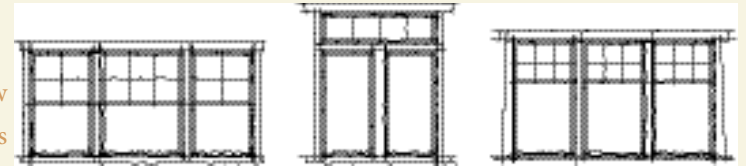

Window
Surrounds

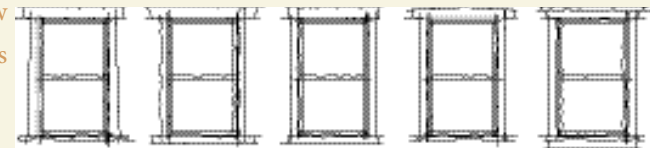

Porch
Columns

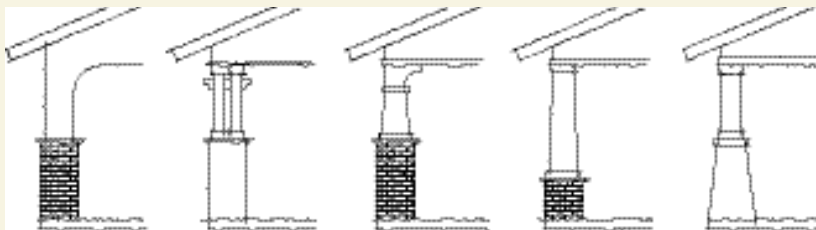

Shutters

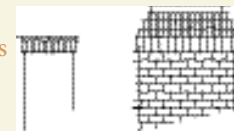

THE CRAFTSMAN BUNGALOW

DETAILS

PICTORIAL EXAMPLES

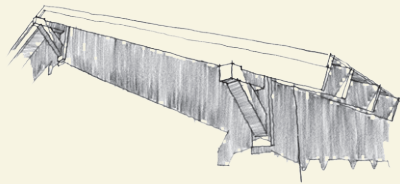

Gable with Knee Brace Detail

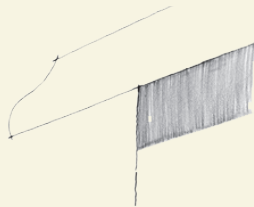

Fancy Cut Rafter

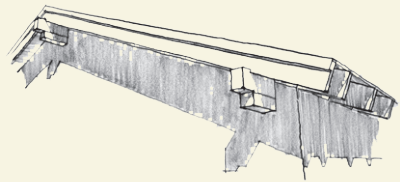

Gable with Outlooker Detail

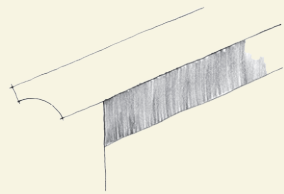

Quarter Round Cut Rafter

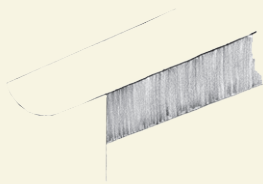

Round Cut Rafter

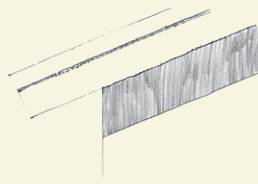

Square Cut Rafter



Historical Representation



Present Day Interpretation

THE PRAIRIE

HISTORY AND INTENT

The Prairie style was borne of the Chicago Prairie School movement. The style is organic in nature, integrated with the land, using natural materials and abstracted nature forms. The Prairie emphasizes the integration of indoor and outdoor areas. Its trademark wide overhangs, appropriate for the Sacramento climate, typically identify the style. Although not as prevalent in the area as the Craftsman style, Prairie homes

are very distinctive and add a strong horizontal presence to the community.

The Hidden Grove Neighborhood Prairie is appropriate for larger lots within the community to emphasize the horizontal nature of the style. Another variation of the style, the two-story Prairie Box (which is a variant of the American Foursquare), can also be appropriate on smaller lots, adding additional diversity to the streetscape.

Distinctive Style Elements

- | | |
|---|---|
| 1 | Two-Story Horizontal Massing |
| 2 | Long Soffited Eave Overhangs |
| 3 | Square or Rectangular Windows with Divided Lights |
| 4 | Chimney |
| 5 | Smooth Stucco |
| 6 | Low Pitched Roof |

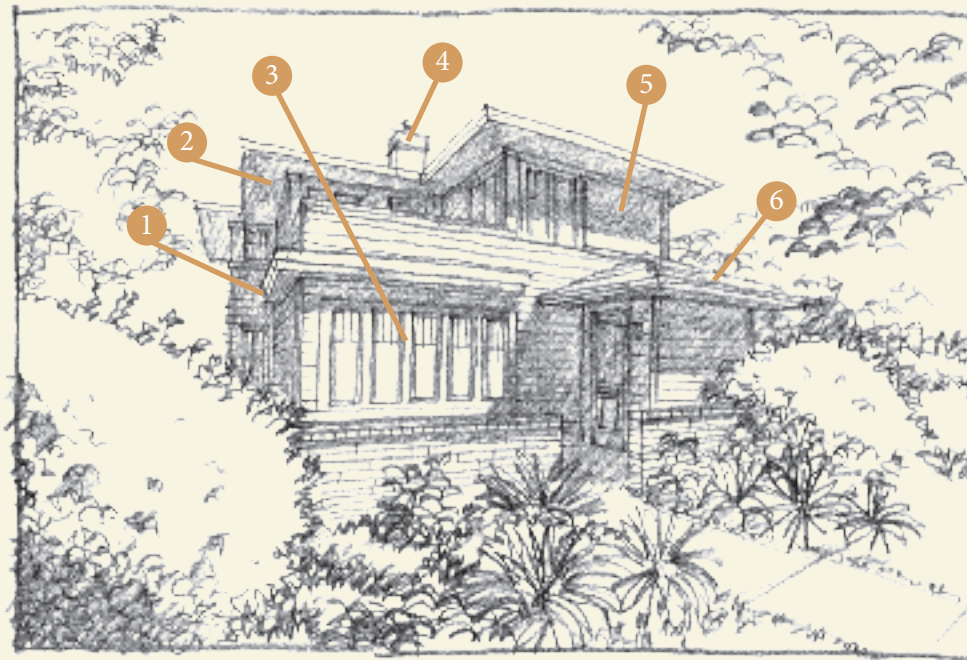

Style Elements	Minimum Elements	Enhanced Elements ¹
Form	<ul style="list-style-type: none"> • One or two-story with horizontal massing. • Secondary masses perpendicular to the primary forms. 	<ul style="list-style-type: none"> • Porte-cocheres (where applicable) and raised porches extending out from the entry of the home. • Accentuated horizontal base extending out as a site or planter wall.
Roof	<ul style="list-style-type: none"> • Long, horizontal low-pitched hip roofs with large over-hanging eaves, emphasizing horizontal planes (3.5:12 to 4:12 roof pitch). • Gable roof forms are also appropriate. • Flat concrete tile with a shingle appearance. 	<ul style="list-style-type: none"> • Terraces covered by primary roof form with massive rectilinear stone piers for roof support.
Walls	<ul style="list-style-type: none"> • Smooth stucco in combination with ledge stone or masonry wainscot base. • Ledge stone used as post bases and fireplaces only. 	<ul style="list-style-type: none"> • Extensive use of brick or ledge stone, used to emphasize the horizontal planes, with struck horizontal grout joints. • Cement plank lap siding is found in some examples.
Windows & Doors	<ul style="list-style-type: none"> • Square or rectangular windows with custom divided lights. • Grouping and arrangement of windows should emphasize the geometry of the elevation. • Ribbons of windows under deep roof overhangs. • Wood window and door trim. 	<ul style="list-style-type: none"> • Clerestory windows. • Leaded glass inserts at entry. • Accent colored window frames.
Details	<ul style="list-style-type: none"> • Massive chimney forms, wrapped in stone or brick. • Ornamental railings and gates. • Wood beams and brackets. 	<ul style="list-style-type: none"> • Metal or wood fascia. • Carpenter detailing. • Style-specific unique lighting fixtures. • Low garden walls to enclose and frame outdoor living spaces.

¹ Minimum three enhanced elements per house are required.

² All corner lots must employ at least four enhancements from the enhanced elements list on all street-adjacent building faces (in addition to the minimum enhancements required for all homes).

THE PRAIRIE

ASSYMETRICAL
HIP

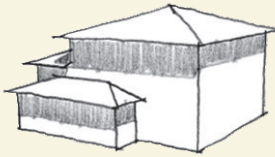

SIDE
GABLE

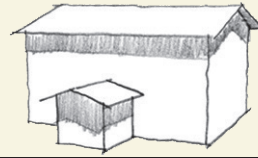

HIP WITH
FRONT ENTRY

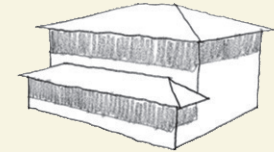

Entry Doors
and
Surrounds

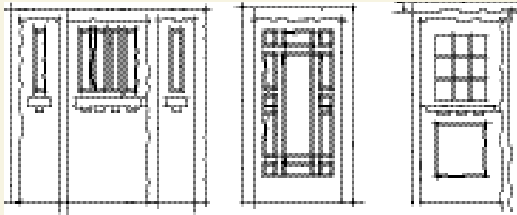

Window
Patterns

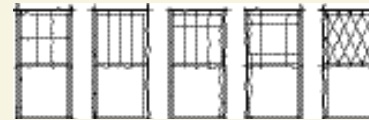

Garage
Doors

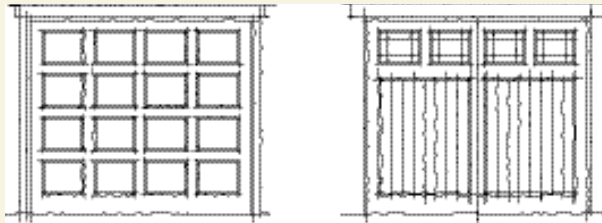

Window
Groupings

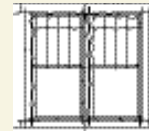

Window
Surrounds

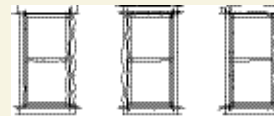

Porch
Columns

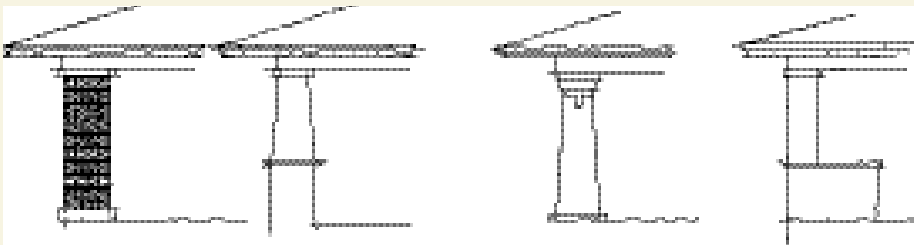

Chimneys



DETAILS

PICTORIAL EXAMPLES



Massing with Hip Roof Form

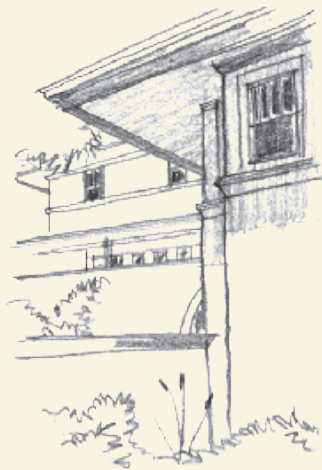

Low Walls, Horizontal Banding,
and Long Overhang



Historical Representation

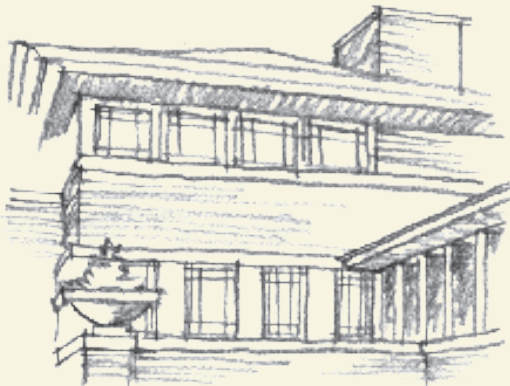

Massing with Horizontal Banding



Prairie Box Alternate



Present Day Interpretation

THE SPANISH ECLECTIC

HISTORY AND INTENT

The Spanish Eclectic house in California gained in popularity and sophistication in surface design after the 1915 Panama-California Exposition in San Diego. The Spanish Eclectic house is popular in all historic neighborhoods, because of its adaptability of form and casual, playful character. Historic

precedence can be drawn from a wide and diverse range of influences; region, chronology, and function (based on urban versus rural examples) all contribute to the evolution of the Spanish Eclectic style. Truly one of the most eclectic architectural styles, the Spanish Eclectic can vary from playful to exotic, bungalow to hacienda.

Distinctive Style Elements

- 1 Arcaded Wing Wall
- 2 Arched Feature Window
- 3 Intersecting Gable Roof
- 4 Parapet Roof
- 5 Barrel Roof Tile
- 6 Multi-Paned Windows



The Hidden Grove Neighborhood Spanish Eclectic style will add to the intrinsic character and rich diversity of the streetscape. Offering an opportunity for bright colors and whimsical forms, the style will add a playful element to the neighborhood.

THE SPANISH ECLECTIC

Style Elements	Minimum Elements	Enhanced Elements ¹
Form	<ul style="list-style-type: none"> • One, one-and-a-half (with strong one story element and stepped back second story), or full two-story massing. (The form is not rigidly defined; this style can be applied to a wide variety of asymmetric building mass configurations.) • Roof form is predominately pitched, hipped or gabled, but may also be parapeted. 	<ul style="list-style-type: none"> • Massive chimney with buttressed form and elaborate cap with arched openings and small tiled roof. • Massive battered (tapered) chimney with finial chimney cap. • Recessed arcade along front elevation. • Arcaded wing wall. • Balconies.
Roof	<ul style="list-style-type: none"> • Low pitched roof (3:12 to 5:12). • Simple flat, hip, or gable roof with one intersecting gable roof. • Overhangs are typically tight, but can be up to 18”. • Fascia is either tight to the building (6” max) or nonexistent with rake tile providing the transition from wall to roof. • Flat concrete tiles. • Exposed rafter tails. 	<ul style="list-style-type: none"> • Barrel or S-shaped concrete tiles. • Boosted roof tiles.
Walls	<ul style="list-style-type: none"> • Smooth or imperfect smooth stucco. 	
Windows & Doors	<ul style="list-style-type: none"> • Feature recessed arched picture window or three grouped arched windows. • Vertical multi-paned windows or inserts at front elevations. • Window head and jamb trim is absent. • Modest (4” max) window sill trim. 	<ul style="list-style-type: none"> • Accent beveled glass recessed window. • Single or grouped arched windows. • Decorative precast concrete door and window surrounds. • Heavy wood head trim at windows. • Thickened walls. • Accent colored window frames.
Details	<ul style="list-style-type: none"> • Shaped rafter tails at feature areas. • Masonry vents. • Canales. 	<ul style="list-style-type: none"> • Shaped rafter rails throughout. • Wrought iron balconies and accent details. • Arched stucco column porches. • Vibrant and colorful glazed Spanish tile accents

¹ Minimum three enhanced elements per house are required.

² All corner lots must employ at least four enhancements from the enhanced elements list on all street-adjacent building faces (in addition to the minimum enhancements required for all homes).

THE SPANISH ECLECTIC

CROSS
GABLE

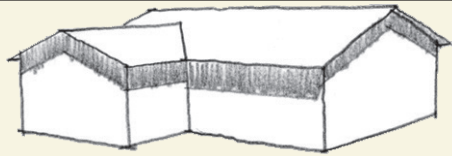

SIDE
GABLE

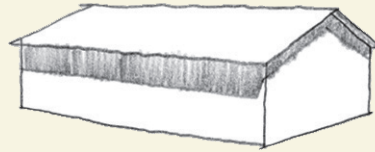

COMBINED HIP
AND GABLE

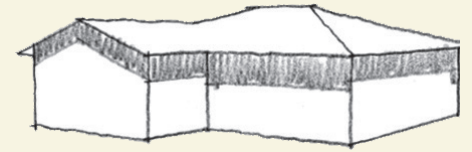

Entry Doors
and
Surrounds

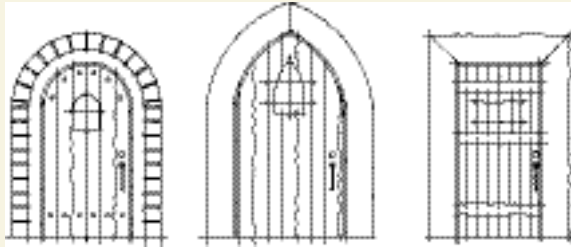

Window
Patterns



Window
Groupings



Garage
Doors

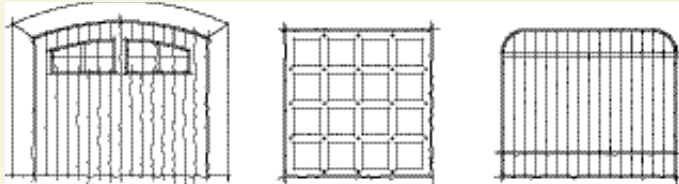

Window
Surrounds



Porch
Columns

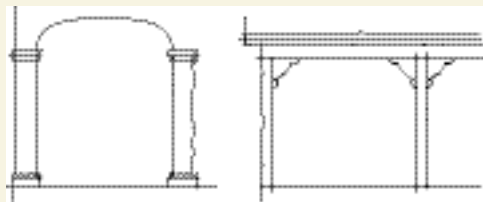

Chimneys
and Shutters



THE SPANISH ECLECTIC

DETAILS

PICTORIAL EXAMPLES

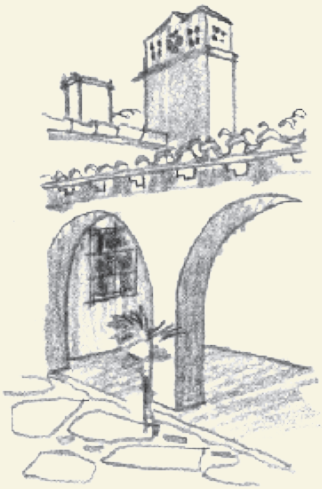

Arches and Chimney
Elaboration



Decorative Vents



Deep Recessed Entry



Historical Representation



Present Day Interpretation

THE FOURSQUARE REVIVAL

HISTORY AND INTENT

The American Foursquare style is a subtype of the Colonial Revival style, comprising about one-third of Colonial Revival houses built before about 1915.

The intent of the Foursquare Revival at Hidden Grove Neighborhood is to bring a formal, stately, and gracious presence to the neighborhood, further enhancing the community's eclectic streetscape.

Distinctive Style Elements

- 1 Large Porch
- 2 Corner Boards
- 3 Large Decorative Frieze
- 4 Shutters
- 5 Pyramidal Roof



Style Elements	Minimum Elements	Enhanced Elements ¹
Form	<ul style="list-style-type: none"> • Two-story, simple rectangular or square form. • Pyramidal hipped roof. • One-story, full-width porch with classical columns. 	<ul style="list-style-type: none"> • Paired porch columns. • Pedimented entry porch accenting center entry door.
Roof	<ul style="list-style-type: none"> • Moderately pitched roof (5:12 to 9:12). • Composition shingle roof. • Moderate overhang (6"-12"). 	<ul style="list-style-type: none"> • Roof dormers, hipped or gabled. • Two-story pilasters at building corners.
Walls	<ul style="list-style-type: none"> • Predominately lap siding with 3"-6" exposure. • Smooth finish stucco. 	<ul style="list-style-type: none"> • Large decorative frieze board.
Windows & Doors	<ul style="list-style-type: none"> • Symmetrically balanced windows. • Door may be centered or placed to the side. • Windows with double-hung sashes, usually with divided lights (divided into six, eight, nine, or twelve panes). • Windows in adjacent pairs. • Window and door surrounds with projecting built-up head trim and projecting sills at windows. • Doors with overhead fanlights or sidelights. 	<ul style="list-style-type: none"> • Bay windows. • Windows with broken segmental or triangular pediments. • Accentuated pedimented front door supported by pilasters, or extended forward and supported by slender columns to form an entry porch. • Accent colored window frames.
Details	<ul style="list-style-type: none"> • Ogee gutter as part of eave detail. • Cornice at roof line. 	<ul style="list-style-type: none"> • Massive central chimney. • Louvered or panel shutters (each shutter must be sized to one-half of entire adjacent window width). • Dentil frieze. • Roof and/or upper porch balustrades. • Leader heads at downspouts.

¹ Minimum three enhanced elements per house are required.

² All corner lots must employ at least four enhancements from the enhanced elements list on all street-adjacent building faces (in addition to the minimum enhancements required for all homes).

THE FOURSQUARE REVIVAL

FORWARD GABLE

SIDE GABLE

ASSYMETRICAL GABLE

Entry Doors
and
Surrounds

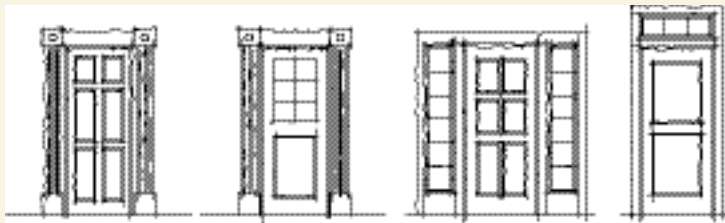

Window
Patterns



Garage
Doors

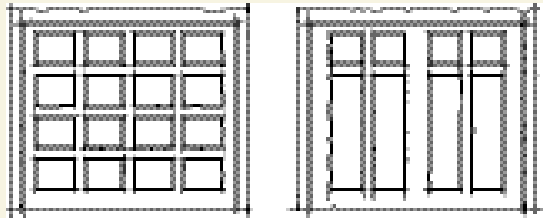

Window
Groupings

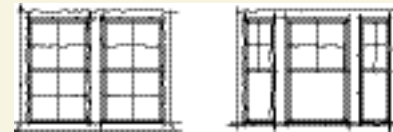

Window
Surrounds



Porch
Columns

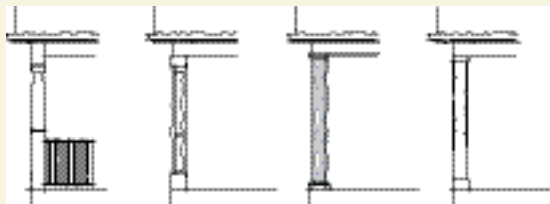

Chimneys
and Shutters



THE FOURSQUARE REVIVAL

DETAILS

PICTORIAL EXAMPLES

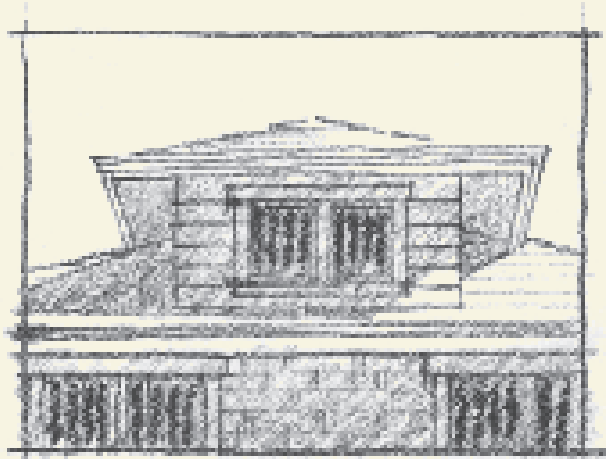

Historical Representation



Present Day Interpretation

THE MONTEREY

HISTORY AND INTENT

The Monterey style blends the Hispanic cultures of the early California residents with the influences brought to the west by the first European settlers. These homes are a juxtaposition of local indigenous materials, with colonial detailing applied. The dominant feature of the Monterey style is the always present upper story balcony element, which is contained

within the principal roof form, and cantilevered. The balcony is of heavy timbered construction, defining the structure.

The Monterey style is a direct link to the colonial heritage of California. These homes will be found on the larger lot sizes of the neighborhood, to provide an authentic representation of the style, and its horizontal nature.

Distinctive Style Elements

- 1 Thin Eaves
- 2 Low Pitched Roof
- 3 French Doors Accessing Balcony
- 4 Two-Story Rectangular Form
- 5 Cantilevered Second-Story Balcony
- 6 Vertical Divided Light Windows
- 7 Louvered Shutters
- 8 Rustic Plank Entry Door
- 9 Decorative Posts and Beams at Cantilever

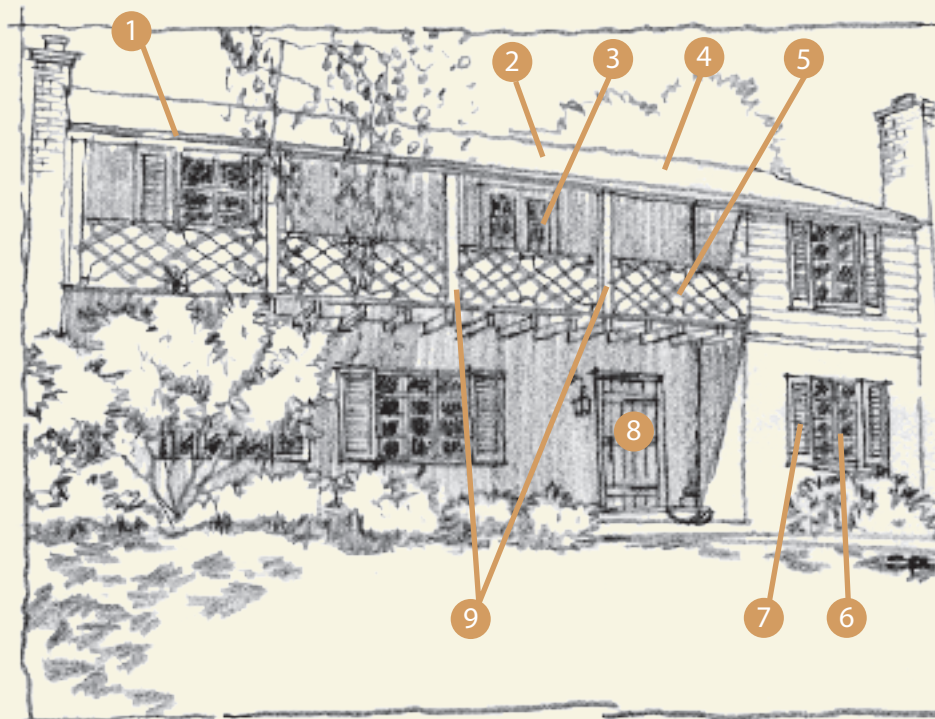

Style Elements	Minimum Elements	Enhanced Elements ¹
Form	<ul style="list-style-type: none"> • Two-story, rectangular form. • Principal side gabled roof. • Cantilevered second story balcony covered by principal roof. 	<ul style="list-style-type: none"> • L-shaped form with front facing cross gable.
Roof	<ul style="list-style-type: none"> • Low-pitched gabled roofs (4:12 to 5:12). • Slate-look tile roof. • 12" to 16" overhangs. • Exposed rafter tails. • Thin eaves with either a half-round or ogee gutter. 	<ul style="list-style-type: none"> • S-tile roof. • Boosted roof tiles.
Walls	<ul style="list-style-type: none"> • Smooth or imperfect smooth stucco is the dominant exterior finish. 	<ul style="list-style-type: none"> • Brick at first floor that may be painted. • Horizontal wood siding at the upper floor. • Thickened walls.
Windows & Doors	<ul style="list-style-type: none"> • Paired windows in groups of twos or threes. • Tall vertical windows. • At least one pair of French doors accessing the balcony. • Rustic plank wood entry door. 	<ul style="list-style-type: none"> • First floor arched picture window at cross gable. • Accent colored window frames.
Details	<ul style="list-style-type: none"> • Fixed panel or louvered wood shutters (each shutter must be sized to one-half of entire adjacent window width). • Wood railing at balcony to match posts and beams. 	<ul style="list-style-type: none"> • Exposed decorative wood elements at balconies. • Ornate wrought iron railing at balcony.

¹ Minimum three enhanced elements per house are required.

² All corner lots must employ at least four enhancements from the enhanced elements list on all street-adjacent building faces (in addition to the minimum enhancements required for all homes).

THE MONTEREY

CROSS
GABLE

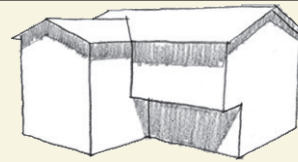

SIDE
GABLE

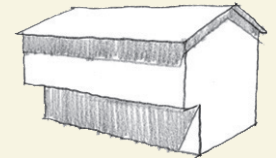

Entry Doors
and
Surrounds

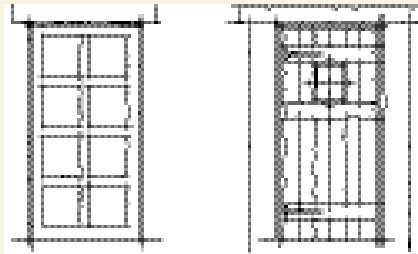

Window
Patterns



Window
Groupings

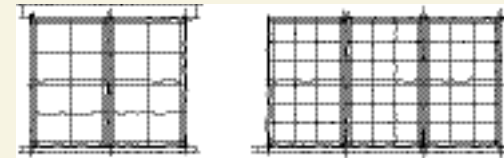

Garage
Doors

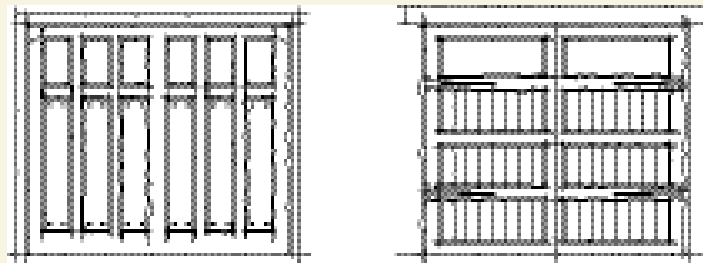

Window
Surrounds

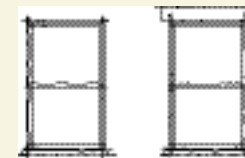

Porch
Columns

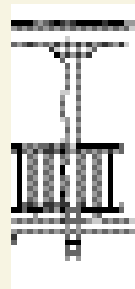

Chimneys &
Shutters

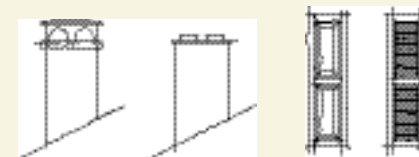

THE MONTEREY

DETAILS

PICTORIAL EXAMPLES



Cantilevered Balcony



Rafter Tail and Downspout



Historical Representation



Gable with Canales, Shutters, and Deep Recess



Present Day Interpretation

MULTI-FAMILY ELEVATION DESIGN PRINCIPLES

Multi-family buildings may be designed with one architectural expression per building or multiple architectural styles with the intent of reflecting the feel of a collection of smaller structures. Architectural styles must be selected from the seven (7) palettes as described in this document.

The building facade should be a combination of elements with heights of up to three stories. The incorporation of style-appropriate porches and balconies is encouraged to provide private outdoor space and additional articulation and shadow play on the structure.

Outdoor amenity spaces, which may include a clubhouse, should be provided in proportion to the size and use of the project. Site structures, such as trash enclosures, carports, and maintenance buildings, should be architecturally complimentary to the project. It is appropriate for accessory buildings such as clubhouses to be architecturally consistent with the residential buildings on the site or be complementary thematically.

Utility meters and other outdoor equipment should be screened from view through a combination of landscaping and site walls designed to be integrated into the design and complementary to the architectural concept.



TOWN CENTER COMMERCIAL ELEVATION DESIGN PRINCIPLES

The Town Center is located at Horseshoe Bar Road near Library Drive. Its central location makes it an ideal walkable destination for nearby residents. The Town Center Mixed-Use may include a range of local-serving uses and professional services placed along Horseshoe Bar Road facing the street. Vertical mixed-use (residential over retail or office) is preferred and encouraged over projects that provide commercial structures on the front portion of the lot with residential uses placed at the rear of the lot (horizontal mix). Parking to the rear is preferred and encouraged. Building materials and colors should draw from the development itself or from the existing neighborhoods along Taylor Road and Horseshoe Bar Road.

