

**STANDARD SPECIFICATIONS  
SANITARY SEWER SYSTEM  
MUNFORD, TENNESSEE**



*Kenneth R. King*  
10-25-17

**KING ENGINEERING CONSULTANTS, Inc.  
PROFESSIONAL ENGINEERS  
3355 POPLAR AVENUE, SUITE 200  
MEMPHIS, TENNESSEE 38111**

**OCTOBER, 2017**

STANDARD SPECIFICATIONS  
SANITARY SEWER SYSTEM  
MUNFORD, TENNESSEE

TABLE OF CONTENTS

Title Page  
Table of Contents

|  | <u>PAGE</u> |
|--|-------------|
| Special Conditions .....   | 1-10        |
| 02722.8.3 PVC Water Mains - SDR-21.....  | 1-2         |
| 02722.8.7 Restrained Joint PVC Pipe (SDR 21) .....   | 1-3         |
| 02730.3 Sanitary Sewer Construction.....   | 1-18        |
| 02731.3 Sewer Force Main Construction .....  | 1-13        |
| 02733.5 PVC Force Main Pipe .....  | 1           |
| 02733.6.1 PVC Gravity Sewer Pipe .....   | 1-2         |
| 02740.1 Manholes.....  | 1-4         |
| 02905.1 Seeding and Landscaping .....  | 1-4         |
| 03001 Concrete .....   | 1-6         |
| 13001.2 Horizontal Directional Drilling for Restrained Pipe C900/RJ or C905/RJ.....          | 1-9         |
| 13001.5 Dry, Wet, and Directional Boring and Work on State Highway .....                     | 1-7         |
| 13015 General Requirements - Telemetry .....   | 1-5         |
| 13955 Telemetry .....  | 1-5         |
| 15050.12 Factory-Built 6x6 Above Ground Pump Station with<br>Duplex Self-Priming Pumps ..... | 1-27        |
| 15113.1 Resilient Seat Gate Valves.....  | 1-2         |
| 15210 Ductile Iron Water Mains .....   | 1-2         |
| Appendix - Standard Details  |             |

**SPECIAL CONDITIONS  
STANDARD SANITARY SEWER SPECIFICATIONS  
MUNFORD, TENNESSEE**

**SC-1.00 NOTICE**

- 1.01 The General Conditions, Special Conditions and all other herein bound and accompanying documents are part of these Specifications and of the Contract. Submission of proposal implies that the Bidder is fully conversant with all requirements of all above-mentioned documents.
- 1.02 Anything mentioned in the Specifications and not shown on the Drawings or shown on the Drawings and not mentioned in the Specifications, shall be of like effect as if shown or mentioned in both.
- 1.03 In case of a difference between the Drawings and the Specifications, the Specifications shall govern. If there are further differences between the Special Conditions and other sections of the Technical Specifications, the Special Conditions shall govern.

**SC-2.00 SHOP DRAWINGS**

Detailed shop drawings, in amplification of the drawings referred to in this Contract, on all equipment, steel, piping arrangements and all other items requiring the Engineer's approval, shall be submitted to the Engineer before proceeding with the work. Five (5) copies of such drawings shall be submitted to the Engineer in the form of blueprints for approval. If approved, two (2) sets of such prints will be returned to the Contractor marked approved. If changes or corrections are necessary, one (1) set will be returned to the Contractor with such changes or corrections noted, and the Contractor shall re-submit corrected or changed prints in five (5) copies. It is understood that the approval by the Engineer of the Contractor's drawings, whether general or detailed, is a general approval relating only to their sufficiency and compliance with the intention of the Contract and shall not excuse or constitute a waiver of error, discrepancies or omissions.

When submitted for the Engineer's review, Shop Drawings shall bear the Contractor's certification that he has reviewed, checked and approved the Shop Drawings and that they are in conformance with the requirements of the Contract Documents.

**SC-3.00 RIGHTS OF ENTRY**

The right to enter on any site of construction or material storage is reserved by the Owner and all Government agencies involved in any way with the project.

**SC-4.00 LIQUIDATED DAMAGES**

Bidder hereby agrees to commence work under this contract on or before a date to be specified in the Notice to Proceed and to fully complete the project within the number of days stated on the Bid Schedule. Bidder further agrees to pay as liquidated damages as stated in the bid for each consecutive calendar day thereafter until completion of the project.

## **SC-5.00 SCHEDULE AND PROGRESS CHART**

- 5.01 Upon starting construction, Contractor shall submit to Owner, a schedule and progress chart which indicates the manner in which he anticipates meeting the time schedule requirements of this Contract. This chart shall be realistic and shall meet the approval of the Owner.
- 5.02 The Contractor shall cooperate in scheduling his work to complete these portions of his Contract as soon as practicable. This scheduling by the Contractor shall meet the approval of the Owner.

## **SC-6.00 MINIMUM INSURANCE AND SAFETY COVERAGE REQUIREMENTS**

- 6.01 All requirements of the Occupational Safety and Health Act and recommendations of the insurance carrier shall be heeded by the Contractor.
- 6.02 **INSURANCE COVERAGE:** The limits of liability for the insurance required in the General Conditions shall provide coverage for not less than the following amounts or greater where required by law:
- A. **Worker's Compensation:** Insurance required in connection with the performance of the work:
    - 1. State: Statutory
    - 2. Applicable Federal: Statutory
    - 3. Employer's Liability: \$500,000
  - B. **Comprehensive General Liability (including Premises-Operations; Independent Contractors' Protection; Products Liability and Completed Operations; Broad Form Property Damage):**
    - 1. Bodily Injury (including completed operations and products liability): \$1,000,000 each occurrence; \$2,000,000 annual aggregate
    - 2. Property Damage: \$1,000,000 each occurrence; \$2,000,000 annual aggregate
    - 3. Property Damage Liability insurance will provide explosion, collapse and underground coverages.
    - 4. Personal Injury, with employment exclusion deleted.
  - C. **Comprehensive Automobile Liability:** Insurance shall cover all owned, non-owned, and hired motor vehicles subject to the following limits:
    - 1. Bodily Injury: \$1,000,000 each person; \$1,000,000 each occurrence
    - 2. Property Damage: \$1,000,000 each occurrence
  - D. **Contractual Liability:**
    - 1. Bodily Injury: \$1,000,000 each occurrence

2. Property Damage: \$1,000,000 each occurrence; \$1,000,000 annual aggregate
- E. Umbrella Excess Liability: \$1,000,000 Single Limit Bodily Injury and Property Damage.

The Contractor shall carry the above-mentioned minimum coverage for the life of the construction project. This coverage may be in the form of a special policy or an Endorsement on the basic policy of the Contractor and additional costs (if any) to Owner will be included in the original Contract Total Bid Amount.

Contractor agrees to purchase such insurance from companies acceptable to Owner, to furnish Owner upon request from time to time with satisfactory evidence that such insurance is being properly carried, and to furnish the Owner and the Engineer with Certificates of Insurance of all policies and/or Endorsements before Owner will issue an order to commence Work.

All Contractor's insurance policies shall name the Owner, Contractor, Subcontractor(s), Engineer, and Engineer's Consultants on the Certificates of Insurance as additional insured.

All insurance policies shall provide that no cancellation or modification of the policy or Endorsement shall be effective until thirty (30) days following the mailing of written notices of such cancellation to the Engineer and to the Owner.

The Contractor alone shall be responsible for the safety, efficiency, and adequacy of his plant, appliances, and methods, and for any damage which may result from their failure or their improper construction, maintenance or operation.

#### **SC-7.00 ADDITIONAL HELP BY CONTRACTOR**

The Contractor will be required to furnish assistance, as needed, to the Resident Inspector in measuring for construction record drawings and/or determination of quantities.

#### **SC-8.00 COMPETENCE OF WORKERS**

Any worker on any part of the work shall be competent to perform the task to which he is assigned. Supervision for each crew shall be done by a foreman or superintendent that is capable of directing the work. Conditions which require the constant presence of an Inspector to assure the quality of the work will not be tolerated. Any worker who does not produce quality workmanship through lack of cooperation or incompetence shall be removed from the job. The judge of quality of workmanship shall be the Engineer.

#### **SC-9.00 UNDERGROUND UTILITIES AND STRUCTURES**

Location of utilities and underground structures shown on the plans are approximate and those shown are not necessarily all of the existing utilities and structures. It is the Contractor's responsibility to determine the exact location and existence of all utilities and underground structures.

### **SC-10.00 CONCRETE**

Unless otherwise specified, concrete shall be 4000 PSI ready mix concrete designed by an independent laboratory. Placement shall meet the requirements of Section 501 of the Standard Specifications for Road and Bridge Construction, Tennessee Highway Department.

### **SC-11.00 FOUNDATION GRAVEL, SAND AND CONCRETE**

Foundation gravel, sand or concrete shall be used when existing conditions require stabilization as determined by the Engineer. Foundation gravel shall be washed rock.

### **SC-12.00 CONSTRUCTION STAKING**

- 12.01 The Contractor shall provide all labor, materials and equipment required to properly stake the work covered by these Specifications with one exception as stated in Paragraph 12.04.
- 12.02 There will not be a separate pay item for this work. Cost for such work will be included in the bid price for the proposed construction.
- 12.03 The sanitary sewer force main shall be installed according to the plans. In order to accomplish this task, it will be necessary for the Contractor to use land-surveying techniques to maintain horizontal control. In some cases, the Contractor will have to install the pipe utilizing horizontal and vertical control. The pipe shall be installed with the aid of cut stakes or a laser beam and cut stakes.
- 12.04 All casing pipe, force main, and sewer main that must be laid on grade are shown on the Plans. This pipe must be installed with the same care and techniques as sanitary sewer mains. Install in accordance with the Sanitary Sewer Construction Section in the technical specifications.

### **SC-13.00 CLEARING**

The cost of clearing shall be included in the cost of items bid. Disposal of debris shall be the responsibility of the Contractor.

### **SC-14.00 GAS MAIN REPAIR**

- 14.01 Gas mains may be within the project limits. Before any construction is begun, the Contractor will have a representative from the gas utility company locate all high-pressure mains, low-pressure mains, and all house service lines that will be crossed during construction. The Contractor shall and hereby does assume entire responsibility for determining the exact location of all gas mains and their proper protection, support and maintenance during all construction operations of this project.
- 14.02 Should the trencher or a backhoe hit or damage the gas main during construction of the sewer lines, the gas main or gas service shall immediately be repaired.

- 14.03 Should the trencher or backhoe yank or bend the gas main substantially, the Contractor shall check the gas main above and below the ditch excavation for possible breaks in the gas main.
- 14.04 Any damage should be followed by a call to the Gas Company and an expert should review the damage and repair before it is backfilled.

#### **SC-15.00 TESTING**

The Owner shall pay the cost of all independent laboratory fees and fees charged by an independent laboratory for field tests during construction of the project. Testing or test results for products such as seed, cement, etc. shall be provided by the supplier to the Contractor for approval by the Engineer.

#### **SC-16.00 EXISTING CONDITIONS**

The Contractor shall be responsible for arrangements to locate underground gas, telephone, electricity, and TV lines. Existing sanitary sewers and water lines shall be adequately located by the Contractor to avoid damage to underground facilities. Excessive and/or irresponsible damage to existing facilities will not be tolerated.

#### **SC-17.00 DRIVEWAY AND STREET REPAIRS**

- 17.01 All drives and street crossings shall be backfilled and tamped with mechanical tampers in 6-inch layers immediately after crossing same. The above shall be done regardless of other methods used for backfilling and compacting of remaining trench. All timber used for temporary traffic support shall be removed before the work is completed.
- 17.02 All backfilled trenches shall be maintained by the Contractor until completion and acceptance of the Owner.
- 17.03 Base limestone shall be compacted to 100% of the standard proctor. The Engineer may approve compaction when no movement is experienced under the weight of a loaded gravel truck or road patrol.
- 17.04 In asphalted areas, the compacted backfill shall be placed to within 10-inches of the top of the street. Limestone as described in these Special Conditions shall be placed on the compacted backfill to a compacted thickness of 8-inches. The final 2-inches shall be 2-inches of compacted asphaltic concrete surface course.
- 17.05 The Contractor shall make such repairs as required to maintain traffic and provide safety on the traffic areas. Temporary limestone base shall be placed in the proper thicknesses and manners to avoid later excavation and regraveling of the base.
- 17.06 The Contractor shall maintain the ditches until his work is substantially completed. The Owner will inspect the areas to be paved prior to beginning of pavement repairs. Street repairs caused by leaks or other defective workmanship will be charged to the Contractor.

### **SC-18.00 ROAD GRAVEL**

- 18.01 Road gravel shall meet the requirements of mineral aggregate Section 303 of the Standard Specifications for Road and Bridge Construction: Tennessee Department of Transportation.
- 18.02 Compaction: 100% of the standard proctor. The Engineer may approve compaction when no movement is experienced under the weight of a loaded gravel truck or road patrol.
- 18.03 Repairs shall be paid for on a linear foot basis.
- 18.04 The granular material is locally known as limestone, CR-610 or simply as "33-C". Any reference on the plans or in the specifications to limestone, CR-610 or "33-C" shall be defined as the above-described granular material.

### **SC-19.00 ASPHALTIC CONCRETE**

- 19.01 Asphalt concrete shall be a standard plant-mixed, hot-laid paving material for roadwork, consisting of clean, crushed rock aggregate, mineral filler, and asphalt conforming to TDOT Specifications: Bituminous Surface Course (TDOT 411-E).
- 19.02 Complete job mix formula, listing quantities and pertinent ingredient properties shall be submitted to and approved by Engineer at least two (2) weeks before work is scheduled to begin.
- 19.03 Asphaltic paving mixture, equipment, methods of mixing and placing, and precautions to be observed as to weather condition of base, etc., shall conform to standard practice for first class road work.

### **SC-20.00 GUARANTEE**

The Contractor shall guarantee all workmanship and materials under this contract for a period of twelve (12) months after final acceptance of the contract and shall, in the event of failure of any item due to workmanship or materials, replace same without cost to the Owner.

### **SC-21.00 CLEAN UP**

After completion of construction, the Contractor shall remove all surplus material, tools, and temporary structures from the site. All rubbish and excess earth shall be removed and the construction site left in a clean, satisfactory condition.

### **SC-22.00 PROTECTION OF LIVES AND HEALTH**

The Contractor alone shall be responsible for the safety, efficiency, and adequacy of this plant, appliances and methods, and/or any damage which may result from their failure or their improper construction, maintenance, or operation.



### **SC-23.00 WORK ON STATE R.O.W.**

Some of the work may be on State R.O.W. The Contractor is responsible for following all T.D.O.T. requirements for working within the R.O.W. The requirements include, but are not limited to, placement of warning signs and notification of T.D.O.T. prior to commencing work. The Contractor is responsible for providing information about equipment, materials, manpower, and work progress to T.D.O.T. representative.

### **SC-24.00 CASING PIPE**

The strength of the steel casing pipe shall have a maximum yield of 35,000 psi. Wall thickness shall be 0.188-inch for casings.

### **SC-25.00 SANITARY SEWER MAIN CONSTRUCTION**

- 25.01 Sewer construction shall meet the requirements of the Sanitary Sewer Construction Section in the technical specifications. Additional requirements of PVC Gravity Sewer Pipe Section in the technical specifications shall be met. Bedding for plastic pipe shall be as specified in the PVC Gravity Sewer Pipe Section in the technical specifications and as shown on the Plans. Four-inch (4") service pipe will not require bedding.
- 25.02 Precise measurements shall be taken to wyes and ends of 4-inch service pipe. Ends of pipe shall be stopped with plugs manufactured for that purpose. Services shall have 54-inches or more of cover when possible.

### **SC-26.00 SELECTION OF EQUIPMENT AND MATERIALS - SANITARY SEWERS**

- 26.01 All equipment items and materials used in the work are subject to the Engineer's approval. They shall be products of reputable manufacturers and shall conform to specification requirements, accepted standard practice and to State, Federal and Municipal laws and regulations. These items shall be the best of respective equipment and materials available for the purpose for which used. Equipment and materials not conforming to specifications will not be considered.
- 26.02 The Contractor shall furnish to the Engineer complete, accurate information regarding all equipment and materials he proposes to furnish. Selection and approval of equipment for use in the work is based in part upon information furnished by the Contractor.
- 26.03 The materials to be used shall conform to the following provisions of the specifications:
- a) CONCRETE - See description previously stated in these Special Conditions.
  - b) SEWER CONSTRUCTION - The sewers shall be constructed as specified in the SANITARY SEWER CONSTRUCTION section in the technical specifications.
  - c) GRAVITY SEWER MAINS – Some of the sewer pipe shall be ductile iron as specified in the DUCTILE IRON WATER MAINS section in the technical specifications. Ductile iron pipe shall have a cement lining of 1/6-inch minimum

thickness. No cement lining will be required for fittings. Some of the sewer pipe shall be PVC as specified in the PVC GRAVITY SEWER PIPE section in the technical specifications.

- d) SEWER FORCE MAIN - The sewer pipe shall be that shown on the bid form. For force main, see the PVC FORCE MAIN PIPE section in the technical specifications.
- e) MANHOLES - Conforming to MANHOLES section in the technical specifications. Sanitary manhole rim shall be equal to Memphis Machine Works No. 7 or Clow F-3650.
- f) ROAD GRAVEL - shall meet the requirements so stated in these Special Conditions.

### **SC-27.00 UNCASED BORE**

The plans call for uncased bore at various locations. The Contractor has the option of using conventional uncased bore techniques with SDR-21 PVC water main inserted in the bore, or he may use directional bore using restrained joint pipe as described in HORIZONTAL DIRECTIONAL DRILLING FOR RESTRAINED PIPE section in the technical specifications.

### **SC-28.00 BORE LENGTHS**

Bores shall be paid for by the lengths shown on the plans. Although it may require more length than that shown on the plans, no more length for bore will be paid for than that shown on the plans.

### **SC-29.00 COMBINATION AIR VALVES**

The air release valves specified in Part 16.00 of the SEWER FORCE MAIN CONSTRUCTION section in the technical specifications shall be 2-inch. Model numbers may change.

### **SC-30.00 GATE VALVES**

Gate valves shall be bevel geared type. See Resilient Seat Gate Valves Section in the technical specifications.

### **SC-31.00 PROTECTIVE COATING OF MANHOLE AND WETWELL**

If called for on the Plans, the manhole or wetwell interior shall be coated as follows:

#### 31.01 Surface Preparation

Allow new concrete to cure 28 days. All concrete surfaces must be clean, dry and free of grease, oil form release agents and foreign matter. All fins and protrusions shall be removed by grinding and scraping. Reference current ASTM D4258 **Standard Practice for Surface Cleaning Concrete for Coating.**

All concrete surfaces shall be Brush-Off Blast Cleaned or otherwise abraded to remove all loose non-bonded, cementitious material, laitance, curing agents and to open surface voids. Do not entirely remove the surface or expose underlying aggregate. Rout out cracks. Reference current ASTM D4259 **Standard Practice for Abrading Concrete and SSPC-SP13, ICRI CSP5.**

All cracks and voids shall be repaired by filling with a non-shrink cementitious mortar.

All residual abrasive, dust or loose materials must be removed using one or more of the surface preparation procedures specified in current ASTM D4258 **Standard Practice for Surface Cleaning Concrete for Coating** such as vacuum cleaning, air blast cleaning, etc. All surfaces must be clean and dry.

#### 31.02 Primer

Apply two coats of Koester VAP 1 pH 200 square foot per gallon per coat. Mix and apply according to label directions.

#### 31.03 First Coat

Apply TNEMEC Series 434 PERMA-SHIELD H<sub>2</sub>S chemical resistant mortar at a nominal thickness of 1/8-inch to all floor areas and walls scheduled to be coated. Application shall either be by trowel or spray. If spray-applied, material shall be finish-trowelled and finish-rolled (Reference manufacturer's application guides for instructions).

#### 31.04 Finish Coat

Apply TNEMEC Series 435 PERMA-GLAZE at a dry film thickness of 15.0-20.0 mils. Application shall be by airless spray and backrolled or by roller or brush in accordance with manufacturer's current product sheet. Roller or brush application may require two or more coats to achieve recommended film thickness.

#### 31.05 Cure

Allow a minimum of three (3) days cure before subjecting to immersion service. Curing time varies with air and surface temperature, air movement, humidity and film thickness.

### **SC-32.00 TELEMETRY – WASTEWATER PUMPING STATION**

32.01 The RTU for the pumping station must be programmed in order to function. The programmer who is familiar with Munford's telemetry system is Robert S. Gaines, P.E. of Gaines Williams & Associates, 1922 Exeter Road, Suite 4, Germantown, TN 38138, 901-756-9065.

32.02 The telemetry system details in the Appendix of these Specifications are based on a previous design by Mr. Gaines. They should be considered to be generic and are not site specific. For this reason, they do not bear a professional engineer's stamp.

32.03 The telemetry system specification in these “Standard Specifications” are based upon a previous design in Munford by Mr. Gaines. They should be considered to be generic and are not site specific. Kenneth R. King’s PE stamp does not apply.

END OF SPECIAL CONDITIONS

**SECTION 02722.8.3**  
**PVC WATER MAINS – SDR-21**  
**MUNFORD, TENNESSEE**

**PART 1.00 NOTICE**

The General Conditions, Special Conditions and all other herein bound and accompanying documents are part of these Specifications and of the Contract. Submission of proposal implies that the Bidder is fully conversant with all requirements of all above-mentioned documents.

**PART 2.00 SDR 21 PRESSURE RATING 200 PSI**

2.01 Pipe must meet all the requirements as set forth in Product Standard PS 22-70 (formerly Commercial Standard CS 256-63) for PVC Type I, Grade 1, PVC 1120 or PVC Type I, Grade 2, PVC 1220 only, with standard dimension ratio (SDR) of the nominal size to the pipe wall thickness of 21, pressure rating of 200 psi, and bear the National Sanitation Foundation Testing Laboratories, Inc., seal of approval for potable water. Lower sustained test pressure ratings of 420 psi for SDR 21 will not be accepted. Pipe must conform to ASTM D2241. Pipe joints must conform to ASTM D3139. Pipe joints shall contain a permanent built in gasket which meets the requirements of ASRM F477. The pipe shall be CAPCO, Griffco, or Ultra-Blue.

2.02 Dimensions in inches shall be as follows:

| <u>NOMINAL<br/>PIPE SIZE</u> | <u>OUTSIDE PIPE<br/>DIMENSIONS</u> | <u>MINIMUM WALL<br/>THICKNESS</u> |
|------------------------------|------------------------------------|-----------------------------------|
| 6                            | 6.625                              | 0.316                             |
| 8                            | 8.625                              | 0.411                             |
| 10                           | 10.750                             | 0.511                             |
| 12                           | 10.750                             | 0.606                             |

2.03 Pipe lengths shall not exceed 20-feet, unless adequate transporting trucks or trailers are available which will adequately support the entire length of a 40-foot joint of plastic pipe. In no case shall length of pipe be less than 3-feet for any size of pipe used.

2.04 Provisions must be made for contraction and expansion at each joint with rubber ring, tapered end and bell as integral part of each full joint with standard dimension ratio SDR 21 being maintained throughout the entire bell section; a factory welded joint with the bell section meeting the latest Commercial Standard for socket type and shall be same material as set forth under Item 2; or Twin gasket Coupling meeting requirements as set forth in Item 2. All plastic fittings, such as Tees, Ells, etc. shall be factory welded, meeting the same specifications as the bell section. Lubricant shall be of the non-toxic type.

- 2.05 Only pipe manufacturers approved by the State Health Department can be used.
- 2.06 Mechanical joint ductile fittings with transition gaskets for plastic pipe shall be used when specified in Special Conditions and/or the bid form. The ductile iron fittings shall conform to the latest revisions of the following specifications:
- ASA, A21.10 Short body cast iron fittings 6-inch to 48-inch.  
AWWA C100 Standard Specification for Ductile Iron Pressure Fitting.
- 2.07 Taps shall be made in accordance with the manufacturer's recommendations with a service saddle approved for use with plastic pipe.

### **PART 3.00 TRACER WIRE**

- 3.01 Tracer wire connector shall be equal to Connector Kings, SA 101, wire splice kit capable of joining three #12 copper wires.
- 3.02 Trace wire shall be connected at the end of one spool and the beginning of successive spools by means of a splice kit. The wires, once connected, shall be inserted into a polypropylene insulator tube with gel to seal the insertion path of the connection. The gel shall be petroleum to resist moisture without breaking down under high temperatures.
- 3.03 All piping shall be wrapped with tracer wire per standard practices. The tracer wire shall have a minimum of 2-feet of wire coiled above the ground at each fire hydrant, air release valve, and 6-inch or 8-inch valve box or 2-inch gate valve or 2-inch blow-off installed. The tracer wire shall be as follows:

#12 AWG, solid copper, type THHN-THWN, black thermoplastic insulated, made in accordance with ASTM designation; BE "Standard Specification for soft or annealed copper wire" as last revised, and Underwriters Laboratories' designation: ANSI/UL 83, "Standard for Thermoplastic Insulated Wires" as last revised.

END OF SECTION

## **SECTION 02722.8.7 RESTRAINED JOINT PVC PIPE (SDR 21)**

### **1.0 SCOPE**

This specification covers thrust-restrained Polyvinyl Chloride (PVC) pipe, 2" - 16", with Iron Pipe Size (I.P.S.) outside diameters. Pipe is intended for use in pressure-rated potable water delivery systems, as well as in sewer force main and fire protection piping systems.

### **2.0 REFERENCE DOCUMENTS**

#### American Society for Testing and Materials (ASTM)

- ASTM D1784 Standard Specification for Rigid PVC Compounds and Chlorinated PVC Compounds
- ASTM D2241 Standard Specification for Poly(Vinyl Chloride) (PVC) Pressure-Rated (SDR Series)
- ASTM D2837 Standard Test Method for Obtaining Hydrostatic Design Basis for Thermoplastic Pipe Materials
- ASTM D3139 Standard Specification for Joints for Plastic Pressure Pipes Using Flexible Elastomeric Seals
- ASTM F477 Standard Specification for Elastomeric Seals (Gaskets) for Joining Plastic Pipe

#### National Sanitation Foundation (NSF)

- NSF61 Drinking Water System Components – Health Effects
- NSF14 Plastic Piping System Components and Related Materials

### **3.0 REQUIREMENTS**

#### **3.1 GENERAL**

Products delivered under this specification shall be manufactured only from water distribution pipe and couplings conforming to ASTM D2241. The restrained joint pipe system shall also meet all short and long term pressure test requirements of ASTM D2241. Pipe, couplings, and locking splines shall be completely non-metallic to eliminate corrosion problems.

#### **3.2 MATERIALS**

Pipe and couplings shall be made from unplasticized PVC compounds having a minimum cell classification of 12454, as defined in ASTM D1784. The compound shall qualify for a Hydrostatic Design Basis (HDB) of 4000 psi for water at 73.4°F, in accordance with the requirements of ASTM D2837. 16-inch high-pressure couplings shall be made from glass-reinforced thermoset filament-wound materials.

### **3.3 APPROVALS**

Restrained joint PVC pipe products shall have been tested and approved by NSF International. 2-Inch through 16-inch PVC pipe and coupling systems up to Class 250 shall be listed in NSF14. All products intended for contact with potable water shall be evaluated, tested, and certified for conformance with NSF 61 by an acceptable certifying organization. Copies of agency approval reports or product listings shall be provided to the Engineer.

### **3.4 DIMENSIONS**

Nominal outside diameters and wall thicknesses of thrust-restrained pipe shall conform to the requirements of ASTM D2241. Thrust-restrained pipe shall be furnished in 2-inch, 3-inch, 4-inch, 6-inch, 8-inch, 10-inch, 12-inch and 16-inch sizes, with pressure ratings from 90 psi to 315 psi.

### **3.5 JOINTS**

#### **3.5.1 COUPLED JOINTS**

Pipe shall be joined using non-metallic couplings to form an integral system for maximum reliability and interchangeability. High-strength, flexible thermoplastic splines shall be inserted into mating, precision-machined grooves in the pipe and coupling to provide full 360° restraint with evenly distributed loading.

Couplings shall be designed for use at or above the rated pressures of the pipe with which they are utilized, and shall incorporate twin elastomeric sealing gaskets meeting the requirements of ASTM F477. Joints shall be designed to meet the leakage test requirements of ASTM D3139.

#### **3.5.2 INTEGRAL BELL JOINTS**

Pipe shall be joined utilizing an integral bell system that does not require couplings. A high-strength, flexible thermoplastic spline shall be inserted into mating, precision-machined grooves in the pipe and integral-bell to provide full 360° restraint with evenly distributed loading. Integral bell shall incorporate an elastomeric sealing gasket meeting the requirements of ASTM F477. Joints shall be designed to meet the leakage test requirements of ASTM D3139.

### **3.6 WORKMANSHIP**

Pipe and couplings shall be homogeneous throughout and free from voids, cracks, inclusions and other defects, and shall be as uniform as commercially practicable in color, density and other physical characteristics.

### **3.7 QUALITY CONTROL**

Q.C. program shall be in accordance with NSF requirements.

### **3.8 MARKING**

Pipe and couplings shall be legibly and permanently marked in ink with the following minimum information:



- Nominal size (for example, 4 In.)
- Outside Diameter System (I.P.S.)
- PVC
- Standard Dimension Ratio (SDR) and pressure rating
- ASTM designation D2241-05 (or latest edition)
- Manufacturer's name or trademark and production record code
- Seal (mark) of the testing agency verifying the suitability of the pipe material for potable water service

### **3.9 APPROVED MANUFACTURERS**

Certa-Lok Yelomine restrained-joint pipe from CertainTeed Corporation, or approved equal.

**END OF SECTION**

**SECTION 02730.3**  
**SANITARY SEWER CONSTRUCTION**

**PART 1.00 NOTICE**

The General Conditions, Special Conditions, and all other herein bound and accompanying documents are part of these specifications and of the Contract. Submission of proposal implies that the Bidder is fully conversant with all requirements of all above mentioned documents. All materials are subject to the Engineer's approval.

**PART 2.00 APPLICABLE PUBLICATIONS**

Standards of American Society for Testing and Materials (ASTM), latest edition, and standard specifications of American Standards Association (ASA), latest edition, shall apply.

**PART 3.00 SCOPE OF WORK**

- 3.01 The work under this section consists of furnishing all materials, accessories, equipment, tools, transportation, services, labor and performing all operations necessary to completely execute the sanitary sewer (all types) work for this project, all as indicated on the drawings, approved shop drawings and as herein specified.
- 3.02 Build all sanitary sewer work of sizes, sections and materials at locations, and to grades shown on the drawings. Provide all concrete work, manholes, junctions, overflows, lateral service connections, and appurtenances, all as indicated on the drawings.
- 3.03 Bidder's proposal and the contract price shall include cost of all incidental work such as removal of trees, roots, timber, masonry structures and all other obstacles, and restoration of existing surfaces, including delay and damage occasioned by same.

**PART 4.00 SHOP DRAWINGS**

Before commencing work, submit for the Engineer's approval shop drawings required in connection with sanitary sewer work. See the General Conditions regarding shop drawings requirements.

**PART 5.00 JOB CONDITIONS**

Refer to the General Conditions for detailed information regarding job conditions requirements.

**PART 6.00 PIPE TESTS**

Refer to Pipe Specification for test requirements.

## **PART 7.00 CONCRETE WORK**

Unless otherwise noted on the drawings or elsewhere specified herein, all concrete work of every description in connection with sanitary sewer work shall be same as specified in the Concrete Section for Class "A" concrete. Refer to drawings and details for locations and extent of concrete items required.

## **PART 8.00 MANHOLES**

Provide all manholes required in connection with the sanitary sewer work, all as indicated on the drawings and approved shop drawings. All manholes shall be of the construction specified in Manholes Section of the specifications for type or types shown on the drawings.

## **PART 9.00 LINE AND GRADE**

9.01 The "sewer grade line" or "sewer flow line" as herein specified means: inside bottom or invert of sewer, whether laid directly on the ground or otherwise supported. All necessary lines, benchmarks, and grades are given on the plans. The Contractor shall provide at his own expense and without extra cost to the Owner, all forms, materials, surveys as required for staking the work.

9.02 The Contractor shall:

- A. Indicate offset distances and excavation cuts on the cut sheets.
- B. Laser beam systems for maintaining line and grade shall be used. The Superintendent will make all setups and adjustments to the laser beam unless other persons are authorized by the resident engineer. A suitable tripod or compression bar will be used to hold the laser beam in a steady position during construction. Machinery operations should not affect the accuracy of the laser beam. The laser beam equipment shall be accurately adjusted and serviced as needed so as to assure proper placement of sewer pipe. A line finder transit will be used above ground to accurately determine the proposed centerline of the sewer pipe. During hot weather, heat waves may affect the accuracy of the laser beam. The Contractor will provide fresh air blowers to cool air inside of sewer pipe. The Contractor shall use manufacturers' recommendations for care and operation of the laser beam and equipment.

## **PART 10.00 REMOVAL OF EXISTING PAVEMENTS**

10.01 Rigid pavements include those incorporating Portland cement concrete surface or base course, bituminous concrete surface and binder course and similar type surfaces and bases. Non-rigid pavements include dirt surface, brick surface, gravel or crushed stone surface, bituminous surface course, and similar type surfacing not constructed on a rigid base.

10.02 Where rigid pavement must be removed to permit trench excavation, the pavement shall be broken out as directed along the edge of the proposed trench. The pavement shall be removed in an approved manner such that the pavement to remain in place is not

disturbed, and shall be disposed of as directed by the Engineer. Where reinforcement is present in the pavement, the pavement removal shall be performed such that the reinforcement may be incorporated in the pavement replacement.

- 10.03 Where non-rigid pavements must be removed to permit trench excavation, the pavement shall be removed to the limits of the trench by the use of an air hammer or other approved equipment.
- 10.04 All cuts shall be perpendicular to the pavement surface and shall be truly and accurately made along a predetermined and carefully marked line. If necessary, a suitable stationary guide shall be used.
- 10.05 Removal of pavement under the jurisdiction of the local State Highway Department shall be performed according to their requirements.

### **PART 11.00 EXCAVATION**

- 11.01 All excavation work for sewers, manholes, sewer structures and appurtenances includes: clearing of site, loosening, loading, removal, transporting and disposal of all excavated materials (wet or dry) necessary to be removed and replaced (backfilling) for purposes of sewer construction. Such work also includes all backfilling operations. All excavations shall be unclassified unless otherwise specified.
- 11.02 Excavate in open trenches unless shown on drawings or directed to be bored and jacked and/or in tunnel.
- 11.03 Excavate trenches to required depth for bedding and foundations of sewers and appurtenances, all as shown on drawings and profiles. Where conditions require, excavate to greater depths, upon Engineer's signed order, stipulating cost of additional work.
  - A. Should trenches be excavated deeper than shown on drawings without the Engineer's signed authority, the Contractor shall at his own expense and without extra cost to the Owner, fill said excess excavation to required elevation with Class C concrete or approved bank run sand, or screened gravel, as directed. Tamp sand or gravel solidly in place.
  - B. Bottoms of all excavations shall be of the shapes and dimensions shown on the drawings.
- 11.04 In general, trenches shall be only of sufficient width to provide a free working space on each side of the pipe sewer according to the size of the pipe and the character of the ground as shown on the plans; but, in every case, there shall be sufficient space between the pipe and the sides of the trench to make it possible to thoroughly ram the bedding around the pipe and to secure proper tight joints. Minimum trench width shall be  $\frac{4}{3}$  diameter of pipe plus 15-inches.
- 11.05 Place excavated materials and materials used in sewer construction so as not to endanger the work and so that there is free access at any time to all parts of trench, to all fire

hydrants, and to all water valves in the vicinity. Provide at all cross streets for free passage of vehicles and pedestrians either by bridging or other approved means.

- 11.06 Where sand backfill is required, the Contractor shall remove all surplus excavated materials from trench and streets as soon as excavated at his own expense and without extra cost to the Owner.
- 11.07 Excavation of trench shall not advance over 200-feet ahead of completed pipework except where it is necessary to drain wet ground in the Engineer's opinion.
- 11.08 The Contractor shall and hereby does assume entire responsibility and risk of encountering quicksand, hardpan, boulder clay, rubbish, unforeseen obstacles, underground conduit and utilities, railroad tracks, pavements, and other obstacles. No claim for extra payment over and above the amount of the contract price for this work will be considered or paid to the Contractor on account of obstacles and character of ground in which trench and other excavations are made.
- 11.09 Where abandoned pipes, conduits, or sewers are removed from the trench leaving dead ends in the ground, such ends shall be carefully plugged or bulkheaded with concrete by the Contractor without additional compensation.
- 11.10 Nothing contained in these specifications relieves or implies relieving any person, firm or corporation owning or using any pipes, conduits, utilities and tracks from the obligation to maintain and protect such pipes, conduits, utilities and tracks without expense to the Owner.
- 11.11 Where rock is encountered in trench excavation, excavate the trench to the width and shape for classified bedding, as directed by the Engineer. Excavate a minimum of 6-inches below the bottom of the pipe. Payment for rock excavation shall be in accordance with the contract prices, or if no prices are included in the contract, in accordance with the Article entitled "Changes" of the General Conditions unless otherwise provided for within these specifications or noted on the drawings.

## **PART 12.00 BLASTING**

In case blasting is done when excavating trench, the Contractor shall and hereby does assume entire responsibility for accidents and damage to public and private property which is caused by blasting operations and the use or storage of explosives. He shall make good at his own expense any and all such damage(s) without extra cost to the Owner.

## **PART 13.00 SHEETING, SHORING AND BRACING**

- 13.01 Shoring and bracing shall be used as safety or ground conditions warrant their use.
- 13.02 Where trenches cannot be opened to provide safe side slopes, the contractor shall provide trench boxes to install pipe, bedding and provide worker safety.

- 13.03 Trench boxes shall be used and maintained in accordance with manufacturer's recommendations and in accordance with State and Federal regulations.
- 13.04 No separate payment will be made using trench boxes. The Contractor shall therefore include compensation in his price per linear foot of sewer.
- 13.05 The Contractor under this contract shall and hereby does assume entire and sole liability for injury to persons and damage to public and private property.

#### **PART 14.00 PROTECTION AGAINST WATER**

- 14.01 Do all pumping, bailing, build all sub-drains and drains in wet trenches, form all dams, flumes, and do all other work necessary to keep all trenches free from water during progress of work and while sewers and their foundations (if any) are being constructed. Protect all newly laid mortar and fresh concrete free from damage resulting from dewatering by means of waterproofed membrane or other approved methods.
- 14.02 Where excavation, for its depth, is wholly or partly in wet sand or where, in the Engineer's opinion, job conditions require, the Contractor shall install a drainage system (gravel sub-drain, well points, etc.) which shall effectively drain water from water-bearing strata.
- 14.03 Where necessary to remove existing sewers, the Contractor shall provide and maintain temporary outlets for all private and public drains, sewers, and catch basins. He shall take care of and discharge all sewage and storm water received from said drains and sewers for which purpose he shall provide and maintain, at his own expense without extra cost to the Owner, an approved, efficient pumping plant and temporary outlets. The Contractor shall at all times properly dispose of all water and sewage received from said temporary connections until permanent connections are made from this section of the specifications.

#### **PART 15.00 FOUNDATIONS**

In case additional excavation below established grade (in order to secure firm foundation) is ordered in writing by the Engineer, fill said additional depth with Class C concrete or solidly compacted washed gravel, as directed. The Contractor will be paid for "foundations" so ordered and constructed beyond the limits for classified bedding. Payment therefore shall be in accordance with the contract prices, or if no prices are included in the contract, in accordance with the Article entitled "Changes" of the General Conditions. The bid price for foundation material in place shall include the cost of additional excavation as required by the Engineer's signed order.

#### **PART 16.00 TYPES OF BEDDING**

Refer to Pipe Specifications and details on Plans for bedding requirements. The price for bedding shall be included in the price bid per foot of sewer pipe.

## **PART 17.00 PIPE LAYING OPERATIONS**

- 17.01 Lay all sewer pipe, under all conditions, in a dry trench, on an even firm bed throughout full length of barrel and so that no uneven strain is placed on any pipe. Maintain dry trench at all times. Conduct all pipe laying operations so as to insure proper subsequent lateral and vertical alignment of pipe and also eliminate groundwater infiltration. Bed pipe full length of barrel shaping bedding material so that a firm, even bearing will result for bottom quadrant of pipe as shown on drawings. Make bell holes carefully (for bell end pipe) and no larger than required to properly free bell from bearing on subgrade or bedding and to properly make pipe joints.
- 17.02 Lay socket end of all pipe upgrade. Insert spigot end of the next pipe into socket until face of spigot is in contact all around with shoulder of pipe. Join pipes in accordance with manufacturer's recommendations.
- 17.03 After pipe is joined, ram and tamp bedding material into bell hole so that no voids occur in the bedding.

## **PART 18.00 BACKFILLING**

- 18.01 After laying sewers, and bedding same in open cut as specified, backfill trenches to original ground surface. Unless otherwise directed, do not leave backfilling unfinished for over 200-feet behind completed pipework.
- 18.02 The Owner reserves the right to withhold pay requests until sewers are properly backfilled and tested.
- 18.03 Maintain existing roadways at intersecting streets for as long a time as possible. In refilling trench, provide and maintain a completely filled, thoroughly compacted roadway across trench ready for traffic at earliest possible time. Where directed, backfill sewer trenches with approved bank-run sand or similar granular material to prevent after-settlement.
- 18.04 Backfill sewer trenches above classified sewer beddings with approved excavated materials (free from organic or other deleterious materials) or bank-run sand to limits shown on drawings.
- 18.05 Type of sewer trench backfill shall conform to requirements as follows:
- A. Compacted: Generally applicable in improved, subdivided areas, in traveled portion of an unimproved street, under a sidewalk or under a paved street for which sand backfill is not directed. Compact and place backfill above the sewer bedding in the following manner:
- 1) Originally excavated materials, exclusive of organic material, boulders, broken pavement or similar materials, shall be deposited in successive horizontal layers, each layer not exceeding 6-inches in thickness. Each layer shall be compacted solidly so that the compacted earth bears the

weight of a heavy piece of equipment without excessive deflection of the backfill. If the Engineer and Contractor cannot agree to this visual test for compaction, then the compaction of the backfill shall meet the standard of 90% Modified Proctor, AASHTO T99 or the same density as the original firm earth, whichever is lesser. Compaction shall be with a sheeps foot roller attached to a trackhoe. Other methods shall be submitted to the Engineer for approval.

- 18.06 In lieu of mechanically compacted backfill, and while not specifically excluded or otherwise restricted on the drawings or in the specifications and/or contract documents, the Engineer may require the Contractor to compact the earth backfill by water jetting where the earth is suitably permeable. Water jetting shall be done in strict conformity with the following requirements.
- A. Compacted earth backfill shall be of same density, after compaction, as the original firm earth of 90% Standard Proctor, whichever is the lesser.
  - B. The Contractor shall provide all required water, hose equipment and accessories, all subject to the Engineer's approval.
  - C. Break any crust which has bridged over the trench.
  - D. Space holes through which water is injected between 5-feet and 8-feet apart, as directed from time to time, and along centerline of trench. Jet all holes. Drilling or auguring is prohibited.
  - E. Carry holes to top of pipe. Inject water pressure just sufficient to sink holes at a moderate rate of speed and without undue cutting and washing. Pipe used to inject water into trench should be 1½-inch to 2-inch in diameter. Pipe should be of adequate length to reach the depth of the sewer pipe. If pump is used, it should be of adequate size to provide the volume needed to flood trench.
  - F. After jetting holes, inject water, at a rate slow enough not to overflow surface, until entire backfill is thoroughly water soaked. Water soaking period shall continue until free water appears on surface of backfill.
  - G. As soon as jetting work is completed, fill all holes with sand or soil as required so that there are no voids or pockets.
  - H. Backfilling by water jetting shall in no way relieve the Contractor from providing backfill compacted to extent and density required under this specification.
- 18.07 Sand: Where trench is in improved streets and pavements and other locations where it is required that after-settlement be minimized and traffic be restored with minimum interruption, place sand backfill in accordance with the following requirements:



- A. Sand used for special backfilling shall be clean and hard grained. Not more than five percent (5%) of humus or dirt shall be present in the sand. Submit samples if requested.
- B. Immediately after placing bedding around sewers where sand backfill is required, backfill sewer trenches with approved material to top of grade in such manner as shall insure immediate compaction of backfill with no after-settlement. If necessary to water jet backfill so as to prevent after-settlement, perform jetting as part of backfill work at no extra cost to the Owner. Such water jetting is subject to the Engineer's signed consent. Maintain approved, suitable surface conditions across trenches until improved surfaces are replaced.
- C. In any event, regardless of the type of trench backfill (compacted or uncompacted), mechanical compaction or sand backfill will be required wherever existing drains or sewers cross the trench excavation. Such compacted earth or sand backfill shall extend up to the center of the crossing line and shall be compacted as herein specified in a manner to prevent after-settlement below the existing pipe. No extra compensation will be allowed for such compaction work and all associated costs shall be included in the respective unit prices for the various contract items of work.
- D. All surplus excavated material not otherwise disposed of on the site shall be removed at once by the Contractor at his own expense.
- E. All rubbish must be removed and the surface must be left in as it was before the commencement of the work, and it must be maintained in such condition during the period of construction and clean up of the entire job.
- F. Ditches shall be opened and connected to any storm water inlets so as to provide for the adequate drainage of the surface of the adjacent lands and ditches.
- G. Backfill within 5-feet of manholes, inlets, and other special structures shall be of the same quality as that specified above for compacted trench backfill. It shall be uniformly deposited on all sides and, unless otherwise permitted, solidly tamped in such manner as to avoid injuring the structures or producing unequal pressures on them.
- H. All backfilling will be paid for under each respective unit price for sewers, and no special or extra compensation will be allowed.
- I. If rock is encountered in the trench, the trench should be excavated 6-inches below grade and filled with ¾-inch or less crushed stone. No stone longer than 6-inches along any axis can be used for backfill.

## **PART 19.00 CHECK DAMS**

Check dams shall be installed in the bedding and backfill of all new or replaced sewer lines to limit the drainage area subject to the french drain effect of gravel bedding. Major rehabilitation projects should also include check dams in the design. Dams shall consist of compacted clay bedding and backfill at least 3-feet thick to the top of the trench and cut into the walls of the trench 2-feet. Alternatively, concrete may be used, keyed into the trench walls. Dams shall be placed no more than 500-feet apart. The preferred location is upstream of each manhole. All stream crossings will include check dams on both sides of the crossing. There shall not be a separate pay item for check dams. The price per foot shall include this work.

## **PART 20.00 ENCASUREMENT (CONCRETE) FOR SEWER PIPE**

Where concrete encasement for sewer pipe is indicated on drawings or otherwise by the Engineer's signed order, provide Class C concrete, as specified in the Concrete Section, including placing and handling thereof. Encasement shall be at least the minimum dimensions indicated on the drawings. Fill entire trench bottom with rammed and compacted concrete or other approved, selected material (as shown on drawings) for entire width of excavation and with no voids or pockets remaining. During construction, support pipe in place on blocks or wedges. Ram and tamp concrete solidly under and around it. Backfill with approved, selected materials as specified in Backfilling for Sewers paragraph. Said backfill shall be included with and considered a part of the concrete encasement.

## **PART 21.00 BORING AND JACKING OPERATIONS**

- 21.01 All boring and jacking operations of steel casing pipes, also installation of sewer pipes in casing pipes are included in the contract, all as shown on drawings, approved shop drawings and as herein specified. Such installation will generally be for crossing under railroads, private rights-of-way, highways, arterial streets, or other special cases. Both casing pipe and carrier pipe shall be provided in lengths short enough for proper placement and handling in the jacking pit.
- 21.02 The work specified herein covers two (2) basic methods of installing casing pipe mechanically (and in which diameter of casing pipe is too small to permit hand working at heading of casing pipe).
- A. Pushing casing pipe into fill or earth simultaneously with boring auger as it drills the earth.
  - B. Drilling hole through the earth or fill and pushing casing and carrying pipe into the hole after drill auger has completed bore.
- 21.03 Open a suitable trench adjacent to slope of embankment or adjacent to bored or jacked section as shown on drawings. Length of approach trench shall be sufficient to accommodate selected lengths of pipe sections to be jacked and wide enough to provide sufficient working space. Set and maintain guide timbers or rails accurately in bottom of approach trench, in order to keep casing pipe on correct line and grade.

Provide and install heavy timber backstop supports by rear of approach trench, adequate to take thrust of jacks without movement or distortion. It is requisite to securing of tolerance limits or boring and jacking operation to set all rails, guides and jacks exactly so that casing pipe in final position is within limits of acceptability as noted on drawings and approved by the Engineer.

- 21.04 Casing pipe shall be of steel and of a diameter and thickness as shown on the drawings. Joints shall be made by continuous weld completely around the perimeter of the pipe. Joint shall be watertight and shall provide a strength through the joint equal to that of the casing pipe. All said requirements are minimum and subject to the Engineer's approval.
- 21.05 Carrier pipes for boring and jacking operations shall be ductile iron with slip joints of thickness, size, and style specified elsewhere in these contract documents, and as shown on the drawings for each location. If not specified elsewhere, ANSI Class 51 ductile iron shall be used. Assemble joints adjacent to casing pipe and push the assembly through casing pipe so that carrier pipe will be on a uniform grade as indicated on drawings. Provide blocking in annular space between carrier pipe and casing if carrier pipe is 10-inches in diameter or greater to prevent floating of carrier pipe inside casing pipe. The blocking shall consist of completely filling the annular space with sand pneumatically placed or pressure grouted with concrete. Bulkheads will be provided at each end of the casing pipe where so shown on the plans.
- 21.06 The Owner will obtain formal approval for rights-of-way. Before starting construction, secure permit by agreement with private companies, Owner, State, County, or Municipal agency as required. Commencing work before securing permit is at the Contractor's risk. The requirements contained within the permits shall be considered a part of these specifications.

## **PART 22.00 MINING AND JACKING OPERATIONS**

- 22.01 Where steel casing pipes of a size adequate to allow mining operation at the pipe heading (generally 36-inch and greater in diameter) are shown on the drawings, the casing may be installed by mining and jacking. The jacking operation will be similar to that specified under Boring and Jacking Operations. Mining shall be performed by hand digging beyond the pipe heading with the pipe jacked to follow such excavation. Mining should in no case proceed more than 12-inches to 18-inches beyond the end of the casing pipe, and if the seal is loose, may be further limited. Excavation should not extend beyond the outside diameter of the pipe. Should excavation extend beyond such limits or if materials slough off during excavation leaving voids outside the casing pipe, then holes shall be drilled in the casing pipe and such voids completely filled by pressure grouting with cement mortar.
- 22.02 During the course of the mining and jacking operation, provisions shall be made for continual accurate checking of line and grade so that no deviation from planned alignment will occur.
- 22.03 Mining and jacking operations shall comply with all pertinent portions of the specification for Boring and Jacking Operations, except that, where shown on the drawings, carrier pipe may be of reinforced concrete pipe as specified under Materials for

Sewers. In such event, placement of the carrier pipe shall include provisions for holding the pipe sections together to preclude any drifting of pipe and/or opening of pipe joints.

### **PART 23.00 JUNCTION WYES FOR HOUSE CONNECTIONS**

- 23.01 Junction tees or wye branches (for house connections) shall be of same material as main sewer, furnished and laid in manner indicated on drawings and in locations directed during construction. Include cost of all stoppers in unit cost for wyes and tees. Where branches are installed for future connections, install watertight stoppers as approved by the Engineer. Branches installed to receive sanitary house connections at a later construction date shall also be plugged with watertight stoppers.
- 23.02 Provide all junction wyes or tees along sewers at points indicated on drawings or as directed during construction. Locate same in front of abutting properties in order to best serve such properties with sanitary sewer outlets for sewage facilities.
- 23.03 Unless otherwise indicated on drawings, place Y-branches in the upper quadrants above horizontal diameter of sewer at angle varying from horizontal, depending on depth of sewer and relative topography of property to be served as shown on drawings or as directed during construction.
- 23.04 For purpose of as-built drawings, record measurements for station of each wye and the end of each house service. Final payment shall not be made without said measurements.

### **PART 24.00 RISERS FOR HOUSE CONNECTIONS**

Construct risers for house connections at sewer depths as shown on the drawings.

### **PART 25.00 SANITARY HOUSE CONNECTIONS**

Construct sanitary house connection or connection sewer similar to that specified for sewers and so approved from junction wye or riser to the location shown on drawings or as directed. Close service line at end socket with approved, suitable PVC cap or stopper, properly sealed (watertight) in place. Lay service pipe at minimum slope of 1/4-inch per foot (1/8-inch per foot with special permission). Terminate at property line.

### **PART 26.00 EXISTING UTILITIES**

The Contractor alone is responsible for locating all underground utilities. All damage to underground utilities shall be repaired immediately without cost to Owner.

The horizontal separation between water and sewer mains shall be at least 10-feet. The distance shall be measured edge-to-edge. When water and sewer mains cross, the vertical separation shall be at least 18-inches between the bottom of the water main and the top of the sewer.

### **PART 27.00 RESTORATION OR EXTENSION OF EXISTING DRAINS OR SEWERS**

- 27.01 Restore or reconnect as directed any existing drain or sewer which is distributed or moved on account or new work under this contract, whether shown on drawings or not and even

though not in conflict with new work. The Contractor shall do all such restoration and reconnection work at his own expense without extra cost to the Owner, except that extension to existing work, new portions of such existing drains or sewers which are authorized by the Engineer's signed order, or relocations ordered by the Engineer to avoid conflict (physical obstruction of existing line due to new sewer pipe, manholes, structures, etc.) will be paid for at the contract price for sewer of the same size or as extra work.

27.02 Build pipe drains and sewers of approved sewer pipe of same quality and dimensions and laid in same manner as specified herein for sewer construction.

27.03 Where existing or restored drains or sewers extend across excavated areas, they shall rest upon compacted backfill. They shall further be supported firmly across the excavated areas by timbering, blocking, masonry or other approved, suitable manner conforming in all applicable cases to requirements herein specified for similar conditions.

### **PART 28.00 EARTH COVERING**

28.01 In conditions where sewers shall be exposed to traffic, cover sewers with approved clean earth fill to a depth of at least 4-feet. In fields and other places not exposed to traffic, fill shall be 36-inches.

28.02 Where additional fill is required over sewer, provide and spread approved, clean earth free from stones, vegetation and other deleterious matter in sufficient quantity so that after thorough compaction, the embankment will be of uniform grade, cross section and of dimensions shown on drawings. This item will be paid for at the unit price bid, or if no unit price is bid, in accordance with provisions for payment of extra work in the General Conditions.

### **PART 29.00 TEMPORARY SURFACES OVER TRENCHES**

29.01 Temporary surfacing shall be constructed to the grade elevation of the undisturbed adjacent surface, subsequent to the backfill operation wherever existing improved street surfacing or pavement is disturbed during construction, in accordance with the following:

A. Gravel: Temporary surfacing shall be constructed of the materials and in accordance with the requirements for State Highway Department. Unless otherwise noted on the drawings, the minimum thickness of the deposited material shall be 6-inches. The temporary surfacing may serve as the final surface.

29.02 Temporary surfacing shall be maintained to grade until restoration of the permanent street or road surface.

29.03 Costs of temporary surfacing shall be included in each respective unit bid price for sewer construction, and no additional compensation will be allowed.

29.04 Temporary surfacing shall be constructed within a reasonable time after the installation of the sewer and backfilling of the trench. It is the intent of this specification that the

surface shall be maintained suitable for normal traffic subsequent to placing of the backfill material. Contractors are advised that where water jetting is used as a method of compaction, continual maintenance, grading, shaping and addition of temporary surfacing material may be necessary during the period while the trench backfill is drying out. In no event will the temporary surfacing and maintenance of same be delayed for prolonged periods awaiting dewatering of the backfill.

- A. If, in the opinion of the Engineer, the temporary surfacing is not being constructed within a reasonable time, the Engineer may order other operations stopped until said temporary surfacing is constructed.

### **PART 30.00 RESTORATION OF SURFACED STREETS AND ROADS**

- 30.01 Improved street drives, sidewalks and other appurtenant street items and road surfaces which are disturbed during construction operations shall be restored in an approved manner and with approved materials to a condition equal to or better than the existing condition before construction began, all as specified herein and/or noted on the drawings. Unless otherwise specified, all restoration work shall conform to applicable provisions of the section entitled Pavement Replacement of the State Highway Specifications.
- 30.02 Restoration of the surface on improved streets and roads shall not be initiated until the base is firm enough to stand the weight of a motor patrol or loaded gravel truck without movement.
- 30.03 Where rigid pavement exists, the existing pavement will be removed to a distance of at least 1-foot outside the edge of the sewer trench. Such removal shall be made in accordance with the part entitled REMOVAL OF EXISTING PAVEMENTS in this section of the specifications.
- 30.04 Portland cement concrete surface shall be restored to the lines and depth as shown on the drawings, or directed by the Engineer, in accordance with applicable provisions of the State Highway Specifications.
  - A. Thickness shall be the same as that of the existing surface but not less than 6-inches.
- 30.05 Bituminous or oiled surfaces shall be restored with a surface approved by the Engineer at least equal to the surface disturbed, but shall in no case be less than that specified in State Highway Specifications. The previously constructed temporary surfacing shall be used as the base course if, as determined by the Engineer, it is in satisfactory condition to receive the surface treatment. The Contractor shall reconstruct the base course to an approved condition if so directed by the Engineer.
- 30.06 Bituminous concrete surface shall be restored to the lines and grades as shown on the drawings or directed by the Engineer in accordance with applicable provisions of the State Highway Specifications.

- 30.07 Gravel surface shall be restored to the grade elevation of the undisturbed adjacent surface with gravel surface course.
- 30.08 Curbs, curb and gutters, drives, sidewalks and other appurtenant street items shall be restored to the shape, depth, width and length of the removed item using materials which are the same as the original construction.
- 30.09 Restoration of surfaces which lie within the jurisdiction of the State Highways shall meet the requirements of the State and these requirements are hereby understood to be a part of these specifications.
- 30.10 When replacement and restoration work is completed, remove all surplus material, earth, and rubbish. Leave surface of each street included in this contract in as good condition as it was before commencement of this work and so approved. Maintain all such street surfaces in approved condition so long as the Contractor is working on the contract.

### **PART 31.00 RESTORATION OF GRASSED SURFACE AREAS**

- 31.01 All original grassed surface areas on both public and private rights-of-way shall be restored to a condition equal to that found prior to the start of work by seeding. All embankments created by the sewer construction shall be seeded.
- 31.02 Seeding shall be done in accordance with the section entitled SEEDING AND LANDSCAPING of these specifications.
- 31.03 Costs of seeding shall be included in a unit price bid for seeding.

### **PART 32.00 CLEANING AND MAINTENANCE OF SEWER**

- 32.01 Exercise care during sewer construction to prevent sand and rubbish (all kinds) from entering or remaining in sewers. Remove rubbish and sand promptly and periodically, as the sewer work progresses. As construction of sewers nears completion, clean entire sewer system thoroughly and make all necessary adjustments, repairs, and replacements throughout entire length of sewers and outfall. Provide all required tools, equipment water (for balling and flushing sewers), and labor for said cleaning and repairs work. Arrange and conduct cleaning and repairs work, as far as practicable, so it and sewer construction work will be completed at the same time. Upon completion of cleaning work, the Engineer will make final inspection of same.
- 32.02 Upon completion of sewer construction, dismantle and remove all building and other structures provided and erected in order to facilitate sewer construction. Remove all rubbish from the ground occupied by said structures and leave entire line of work clean, in good condition and so approved. Include cost of all cleaning, repairs, maintenance and leaving sewers ready for operation in unit price bid by the Contractor for all sewer pipe in place complete.

## **PART 33.00 INSPECTION**

On completion of each block or section of sewer or at such times as the Engineer may direct, a block or section of sewer shall be cleaned, tested and inspected. All repairs shown necessary by the inspection shall be made. Broken or cracked pipe shall be replaced; defective joints, if any, replaced; all deposits removed; and the sewer left true to line and grade, entirely clean, free from lumps or protruding jointing material, etc., and ready for use. Each section of sewer between manholes shall show, upon examination from either end, a reasonably full circle of light.

### **34.00 METHODS OF TESTING**

#### 34.01 Low Pressure Air Test:

- A. Clean pipe to be tested by propelling snug fitting inflated rubber ball through the pipe with water. Plug all pipe outlets with suitable test plugs. Brace each plug securely. If the pipe to be tested is submerged in ground water, insert a pipe probe by boring or jetting, into the backfill material adjacent to the center of the pipe, and determine the pressure in the probe when air passes slowly through it. This is the back pressure due to ground water submergence over the end of the probe. All gauge pressures in the test should be increased by this amount. Add air slowly to portion of the pipe installation under test until the internal air pressure is raised to 4.0 PSIG. After an internal pressure of 4.0 PSIG is obtained, allow at least two (2) minutes for air temperature to stabilize, adding only the amount of air required to maintain pressure. When pressure decreases to 3.5 PSIG, start stopwatch. Determine the time in seconds that is required for the internal air pressure to reach 2.5 PSIG. Minimum permissible pressure holding times for runs of single pipe diameter and for systems of 4-inch, 6-inch, or 8-inch laterals in combination with trunk lines are indicated in the following tables in seconds. The air test may be dangerous if, because of ignorance or carelessness, a line is improperly prepared. It is extremely important that the various plugs be installed and braced in such a way as to prevent blow outs. Inasmuch as a force of 250-pounds is exerted on an 8-inch plug by an internal pipe pressure of five (5) psi, it should be realized that sudden expulsion of a poorly installed plug or of a plug that is partially deflated before the pipe pressure is released can be dangerous.

As a safety precaution, pressurizing equipment should include a regulator set at perhaps ten (10) psi to avoid over-pressurizing and damaging an otherwise acceptable line. No one shall be allowed in the manholes during testing.



AIR TEST TABLES

MINIMUM HOLDING TIME IN SECONDS REQUIRED  
FOR PRESSURE TO DROP FROM 3-1/2 TO 2-1/2 PSIG

| LENGTH<br>OF LINE<br>IN FEET | 4"  | 6"  | 8"  | 10" | 12" | 15" |
|------------------------------|-----|-----|-----|-----|-----|-----|
| 25                           | 4   | 10  | 18  | 28  | 40  | 62  |
| 50                           | 9   | 20  | 35  | 55  | 79  | 124 |
| 75                           | 13  | 30  | 53  | 83  | 119 | 186 |
| 100                          | 18  | 40  | 70  | 110 | 158 | 248 |
| 125                          | 22  | 50  | 88  | 138 | 198 | 309 |
| 150                          | 26  | 59  | 106 | 165 | 238 | 371 |
| 175                          | 31  | 69  | 123 | 193 | 277 | 425 |
| 200                          | 35  | 79  | 141 | 220 | 317 |     |
| 225                          | 40  | 89  | 158 | 248 | 340 |     |
| 250                          | 44  | 99  | 176 | 275 |     |     |
| 275                          | 48  | 109 | 194 | 283 |     |     |
| 300                          | 53  | 119 | 211 |     |     |     |
| 350                          | 62  | 139 | 227 |     |     |     |
| 400                          | 70  | 158 |     |     |     |     |
| 450                          | 79  | 170 |     |     |     |     |
| 500                          | 88  |     |     |     |     |     |
| 550                          | 97  |     |     |     |     |     |
| 600                          | 106 |     |     |     |     |     |
| 650                          | 113 | 170 | 227 | 283 | 340 | 425 |

NOTE: TO BE USED WHEN TESTING ONE DIAMETER ONLY.

- B. Vacuum test shall be conducted on newly constructed manholes. Before entering any manhole, follow all local, state, and federal safety precautions.

Plug all manhole entrances and exits other than the manhole top access using suitably sized pneumatic or mechanical pipeline plugs. Make sure plugs are properly rated for the pressures required for the test. The standard test is equivalent to approximately 5 PSIG backpressure. It is recommended that the plugs be rated a minimum of 10 PSIG backpressure. Brace inverts if lines entering manhole have not been backfilled to prevent pipe from being dislodged and pulled into the manhole. Install the vacuum tester head assembly at the top access of manhole. Adjust the cross brace to insure that the inflatable sealing element inflates and seals against the straight top section of the manhole if possible. Attach the vacuum pump assembly to the proper connection on the test head assembly. Make sure the vacuum inlet/outlet valve is in the closed position. Inflate sealing element to the manufacturers recommended inflation pressure. Start the vacuum pump assembly engine and allow preset RPM to stabilize. Open the inlet/outlet ball valve and evacuate the manhole to 5 PSIG. Do not pressurize the manhole. Close the vacuum inlet/outlet ball valve and monitor vacuum

for specified test period (see table). If vacuum does not drop in excess of 1-inch Hg., manhole is considered acceptable. If manhole fails the test, complete necessary repairs and repeat test until satisfactory results are obtained.

| <u>Depth of<br/>Manhole (Feet)</u> | <u>Manhole<br/>Diameter (inches)</u> |            |            |
|------------------------------------|--------------------------------------|------------|------------|
|                                    | <u>Time (seconds)</u>                |            |            |
|                                    | <u>48"</u>                           | <u>60"</u> | <u>72"</u> |
| 8                                  | 14                                   | 18         | 23         |
| 10                                 | 17                                   | 23         | 28         |
| 12                                 | 21                                   | 28         | 34         |
| 14                                 | 25                                   | 32         | 40         |
| 16                                 | 28                                   | 37         | 45         |
| 18                                 | 32                                   | 41         | 51         |
| 20                                 | 35                                   | 46         | 57         |
| 22                                 | 39                                   | 51         | 62         |
| 24                                 | 42                                   | 55         | 68         |
| 26                                 | 46                                   | 60         | 74         |
| 28                                 | 49                                   | 64         | 80         |
| 30                                 | 53                                   | 69         | 85         |

**PART 35.00 COMPETENCE OF WORKERS**

Any worker on any part of the work shall be competent to perform the task to which he is assigned. Supervision for each crew shall be done by a foreman or superintendent that is capable of directing the work. Conditions which require the constant presence of the Engineer to assure the quality of the work will not be tolerated. Any worker who does not produce quality workmanship through lack of cooperation or incompetence shall be removed from the job. The judge of quality of workmanship shall be the Engineer.

**PART 36.00 EXISTING MANHOLE CONNECTIONS**

- 36.01 Where required, old manholes shall be reworked to divert the sewage into the new sewer. Existing lines below the manhole shall be plugged. Finished lines below the manhole shall be plugged. Finished invert shall be formed as shown on the manhole detail.
- 36.02 The price bid for connection to an existing manhole shall include reworking the invert in the locations where this type of connection is planned. Construction of a new manhole over an existing sewer will not be classified as connecting to an existing manhole.

**PART 37.00 GUARANTEE**

- 37.01 The Contractor shall and hereby does guarantee that all material and work for sanitary sewer work shall be free from defects of material and labor and shall be and remain in good condition for a period of one (1) year from date of Owner’s final acceptance of same.

37.02 The Contractor shall and hereby does further agree that he will, at his own expense and without extra cost to the Owner, remove, repair and replace all said defective work occasioned by operations under this section of the specifications which occur during the one (1) year guaranty period, and that he will also make good at his own expense and without extra cost to the Owner, any and all damages to other work caused by such repair and replacement operations.

**PART 38.00 MINIMUM SEWER GRADES**

All sewers should be constructed at the following minimum grades:

| <u>SEWER SIZE</u> | <u>MINIMUM SLOPE IN<br/>FEET/100-FEET</u> |
|-------------------|---|
| 6"                | 0.6                                       |
| 8"                | 0.38                                      |
| 10"               | 0.26                                      |
| 12"               | 0.193                                     |
| 14"               | 0.151                                     |
| 15"               | 0.123                                     |
| 16"               | 0.112                                     |
| 18"               | 0.103                                     |
| 21"               | 0.088                                     |
| 24"               | 0.072                                     |

END OF SECTION

**SECTION 02731.3**  
**SEWER FORCE MAIN CONSTRUCTION**  
**WASTEWATER PUMPING SYSTEM**

**PART 1.00 GENERAL**

The General Conditions, Special Conditions and all other herein bound and accompanying documents are part of these Specifications and of the Contract. Submission of proposal implies that the Bidder is fully conversant with all requirements of all said documents. All materials specified herein are subject to the Engineer's approval.

**PART 2.00 SCOPE OF WORK**

- 2.01 The work in this section consists of furnishing all materials, accessories, equipment, tools, transportation, services, labor and performing all operations required to execute sewer force main (all types) work for this project, all as indicated on the drawings and herein specified. Provide all sewer force main work in place complete.
- 2.02 Bidder's proposal and the contract price shall include cost of all incidental work such as removal of trees, roots, timber, masonry structures and all other obstacles, and restoration of existing surfaces, including delay and damage occasioned by same.

**PART 3.00 JOB CONDITIONS**

Refer to the General Conditions for detailed information regarding job conditions requirements.

**PART 4.00 SHOP DRAWINGS**

Before commencing work submit for the Engineer's approval, complete shop drawings as required for force main work. See the General Conditions for detailed information regarding shop drawings requirements.

**PART 5.00 INSPECTION**

- 5.01 Inspection of pipe and materials will be made at the point of destination. The Engineer reserves the right to provide factory inspection as necessary.
- 5.02 In case any pipe, fittings, and special castings delivered at the site(s) do not conform to specifications requirements, they will be rejected. The Engineer may appoint a competent inspector who shall inspect all such work at manufacturer's plant(s).

**PART 6.00 HANDLING AND STORAGE**

- 6.01 Handle all pipe, special fittings, valves, castings and other accessories with care in accordance with manufacturer's recommendations. Lift by hoists and slings or slide or roll same on skidways in a manner to prevent damage. Dropping and bumping against pipe, accessories or other objects on ground are prohibited. Do not damage coating;

repair coating if damaged. Replace all pipe or other items damaged in transit from shop or from cars to job site, in unloading and after delivery without extra cost to the Owner.

- 6.02 The Contractor shall and hereby does assume responsibility for the safe storage of all materials furnished by or to him and accepted by him, required for this work, and until said materials are incorporated in same.

## **PART 7.00 EXCAVATING**

- 7.01 This paragraph applies to excavating for all types of pipe.
- 7.02 Do all excavating by any approved, customary method, to shapes and alignment shown on the drawings and of whatever material encountered. Excavating shall be unclassified. No extra compensation will be allowed for rock or hard pan unless a predetermined unit price is specified for it (herein or in the proposal form). Excavate only so far as directed in advance of pipe laying.

Trench-digging machinery may be used, subject to the Engineer's approval, except in places where its operations will cause damage to trees, buildings, or existing structures, above or below ground. In such cases use hand methods.

- 7.03 Trench width may vary with and depend on depth, also on nature of excavated materials encountered. In any case, width shall be ample to permit proper laying and jointing of pipe, also proper placing and compaction of backfill. Minimum width of unsheathed trench (measured at top of pipe) shall be 12-inches plus outside diameter of bell or water main to be laid therein. Increase width of trenches necessary or directed where sheathing and shoring are required. Maximum width of trench (measured at top of pipe) shall be 24-inches plus nominal diameter of pipe. Minimum depth shall be such that there is at least 3-feet of cover measured below surface of roadway or natural ground to top of pipe, except as otherwise indicated herein or shown on the plans.
- 7.04 Trench shall have flat bottom, conforming to grade to which pipe is laid. Dig bell or coupling holes of proper sizes in earth at each joint to permit proper jointing of pipe and to permit barrel of pipe bearing on solid foundation for full length of barrel.
- Earth mounds can be used for pipe support if the trench bottom is firm, and if firm mounds can be built that will hold pipe from settling during and after assembly until finally backfilled.
- 7.05 Pile all excavated materials at sides of trenches, beyond reach of slides, and so it does not endanger the work nor obstruct streets, roads and sidewalks, and with minimum inconvenience to public travel and occupants of adjoining property. If necessary to pile excavated material on sidewalks, erect barriers to keep earth at least 4-feet from fronts of all buildings. Provide access to all private property.
- 7.06 Where excavating through cinder fills, rock and other unsuitable backfill materials, excavate trench an additional 6-inches deep. Tamp selected clean earth into trench to bottom of pipe.

- 7.07 After installing pipe, backfill and tamp trench around sides of same and to thickness 6-inches above top of pipe with said selected clean earth. Backfill material above this level may be any kind of earth materials, but shall not contain cinders, boulders, broken concrete or similar unsuitable backfill materials.
- 7.08 Correct any part of trench which is excavated below grades specified or shown on drawings by filling low portions with approved materials, solidly compacted.
- 7.09 Provide and maintain during construction progress (and until trenched highway is safe for traffic), approved, adequate barricades, construction and warning signs, red lights, flares and guards. Observe all State and Local laws, ordinances, rules, regulations and provisions, also rules and regulations of utilities, respecting construction and safety.
- 7.10 Leave unobstructed and accessible during entire construction period except by traffic safeguards the following items:
- A. Valve pit covers
  - B. Valve boxes
  - C. Other utility controls
- 7.11 Make approved, adequate provision for and maintain flow of all sewers, drains and water courses encountered during construction period.
- 7.12 Wherever ground is sufficiently firm, lay pipe directly on bottom of trench or on earth mounds. Wherever necessary and shown on the plans provide approved timber or plank under pipe, without extra cost to the Owner.
- 7.13 Where trench bottom is soft and cannot support pipe, excavate trench deeper and wider and refill same with selected material, properly compacted to assure firm foundation for pipe, as directed.
- 7.14 Maintain roadways at intersecting streets as long as possible. Where necessary, provide timbering, planking or metal runways.

## **PART 8.00 SHORING AND BRACING**

Wherever character of ground necessitates protecting the work, street, road or employees, shore and brace trenches in approved, suitable manner. The Contractor shall and hereby does assume responsibility for adequacy and safety of all shoring, bracing and sheathing work.

## **PART 9.00 DEWATERING**

All pumping and bailing, building of all drains and all other work, also furnishing of all materials, fuel, electric current and personnel necessary to keep trenches and excavations for sewer force mains work free of water at all times during progress of construction, is included in this contract, under this section and shall be done without extra cost to the Owner. Provide means of conveying water from excavation to approved discharge point.

## **PART 10.00 STREETS AND ROADS**

- 10.01 This paragraph applies to all streets, roads and drives inside and outside corporate limits of the Municipality.
- 10.02 Removals and replacements of surface and structures mentioned herein shall be done as part of this contract, payment to be made for paving at the unit prices bid.
- 10.03 When removing materials of salvageable nature (in suitable condition and so approved) for reuse as directed, do such work carefully and keep such materials separate from the other excavated materials. After laying pipe and backfilling, replace said materials in as good and safe condition as they were before removal. Removals and replacements apply to and include existing planting, culverts, tile and other drainage structures.
- 10.04 Remove materials of unsalvageable nature as a unit (such as paving, road and drive surfaces, curbs, concrete and brick sidewalks and similar materials) by approved, customary methods of excavation. Where removed, replace road and drive surfaces to original condition. Replace concrete and brick sidewalks and curbs (where removed) to same shapes and dimensions as they were originally. Salvageable materials, such as brick, may be reused in replacement of surface, provided they are in suitable condition and so approved.

## **PART 11.00 GENERAL INSTRUCTIONS LAYING PIPE**

- 11.01 Lower each separate length of pipe into trench by means of derrick, crane, slings, ropes or other suitable methods with approved tools and equipment. Use care to prevent damage to pipe or coating. Dropping or dumping pipe into trench is prohibited. Do not lay pipe in water, mud or on frozen subgrade.
- A. Before lowering and while pipe is suspended, inspect same for defects. Defective, damaged and unsound pipe will be rejected. Replace same without extra cost to the Owner.
- B. Before lowering pipe into trench, remove all dirt and other foreign matter from the interior. Keep all pipe clean and free of dirt, trench water, and foreign matter during and after laying. Do not damage coating.
- 11.02 Lay all pipe on firm bed. Lay pipe line straight. Excavate under each bell or coupling so that entire length of pipe will lie on bottom of trench and not on bells or couplings. Earth mounds, as previously described, will be accepted.
- 11.03 Unless otherwise directed, lay all pipe (all types) with flange or bell ends facing in direction of laying. For lines with appreciable slope, face flange or bell ends up-grade, when directed.
- 11.04 Do all required cutting of pipe (all types) for inserting valves or closure pieces in an approved manner and without damaging pipe.

## **PART 12.00 SPECIAL PRECAUTIONS LAYING PIPE**

- 12.01 If the force main is improperly installed, air pockets in the main will occur. The formation of air pockets results in a higher amount of friction loss than the pumps were designed to pump against. The plans show positive and negative grades that result in high points, at which air release valves are located.
- 12.02 The Contractor shall be responsible for installing a pipeline that will not pocket air. The plans show invert elevations which are designed to accomplish this purpose. The Contractor shall take adequate elevations ahead of construction to determine that a rise or drop in ground level is anticipated and adjustments made to avoid air pockets and achieve the needed pipe cover.
- 12.03 In order to achieve the grades shown on the plans, the Contractor has the option of using a laser beam as discussed in Part 12.08 or having a surveyor's level on the project continually. If the latter option is selected, a shot must be taken on the end of each joint to ensure that the end of each joint is either rising or falling as per the profiles of the plans.
- 12.04 If a level is used to install the main, records of elevations must be kept.
- 12.05 Sewer force main shall be laid with tracer wire.
- 12.06 The force main shall be the material shown on the bid form.
- 12.07 Thrust blocking requirements are shown at the end of this section.
- 12.08 Laser beam systems for maintaining line and grade shall be used. The Superintendent will make all setups and adjustments to the laser beam unless other persons are authorized by that resident engineer. A suitable tripod or compression bar will be used to hold the laser beam in a steady position during construction. Machinery operations should not affect the accuracy of the laser beam. The laser beam equipment shall be accurately adjusted and serviced as needed so as to assure proper placement of sewer pipe. A line finder transit will be used above ground to accurately determine the proposed centerline of the sewer pipe. During hot weather, heat waves may affect the accuracy of the laser beam. The Contractor will provide fresh air blowers to cool air inside of sewer pipe. The Contractor shall use manufacturer's recommendations for care and operation of the laser beam and equipment.

## **PART 13.00 FORCE MAIN GRADES**

The profiles of the sewer force main plans show grades on the pipe and invert elevations at the change in grades. The purpose of these data is to ensure that air pockets do not occur at points other than where air release valves are proposed. The formation of air pockets results in a higher amount of friction loss than the pumps were designed to pump against.

The grades may be varied from those shown on the plans only under the following conditions:

- A. If the profiles show a positive grade, the installed pipe must be laid on a positive grade.



- B. If the profiles show a negative grade, the installed pipe must be laid on a negative grade.
- C. The cover over the pipe, which is shown on the plans, must be maintained as a minimum.

#### **PART 14.00 TRACER WIRE FOR FORCE MAIN**

All plastic piping shall be wrapped with tracer wire per standard practices. The tracer wire shall have a minimum of 2-feet of wire coiled inside the valve box and the manhole at each air release valve installed. The tracer wire shall be as follows:

#12 AWG, solid copper, type THHN-THWN, black thermoplastic insulated, made in accordance with ASTM designation; B3 “Standard Specification for soft or annealed copper wire” as last revised and Underwriters Laboratories designation: ANSI/UL 83, “Standard for Thermoplastic-Insulated Wires” as last revised. Splices to be made using a 3M Direct Burial Splice Kit, which is in a plastic sleeve. (Waterproof)

#### **PART 15.00 TRACER WIRE MARKERS AND TEST STATIONS**

Every 1000-feet of force main shall be marked by a Rhino Triview marker having a manufacturer’s number of TVTIN 66 GB2R. The marker shall be 66-inches and buried 3-feet in the ground. The marker shall have two inside terminals. The marker shall serve two purposes. One purpose is to mark the line. The other purpose is to serve as a termination point for the tracer wire to be used in conjunction with the inductive locator.

Each marker shall have one high performance decal with the words “WARNING SEWER PIPE BELOW”. The decal shall be 3M cast vinyl sheeting with UV shield protective coating.

#### **PART-16.00 AIR RELEASE VALVES AND MANHOLE**

The air release valves and manholes shown on the drawings are diagrammatic. Air release valves and manholes must be located at the high points of the pipe. The items shown on the detail shall be paid for under the bid item “Valve and Manhole”. The same is true for the combination air/vacuum release valve.

The combination valve shall be A.R.I., nylon body, sized to meet the force mains maximum capacity or approved equal.

The size(s) of the valve(s) is/are shown on the plans and/or bid form.

No other air release valves than those shown on the plans should be needed. If the Contractor installs the force main in such a manner that air entrapment occurs so that pumping rates are effected, additional air release valves shall be installed at air entrapment points at his own expense.

#### **PART 17.00 CONNECTIONS AND BLOCKING**

17.01 Cap or plug in approved manner all unconnected ends of all crosses, tees, branches and wyes. Properly block with concrete against solid unexcavated earth to take reaction of the following items: all pipes laid around curves and on unsupported changes of direction, all tees, crosses and other fittings. Secure all plugs at blanked openings with

blocks or concrete. All concrete shall be as specified in the Concrete section. Blocking shall be included in price per linear foot of pipe.

- 17.02 Locations of connections, sizes of existing mains and connections with same shown on drawings attached hereto and hereby made a part hereof, are approximate only. The Contractor shall provide in place complete, proper connections required within limits shown on the drawings.
- 17.03 Connections with existing mains, cutting of pipe, special castings, plugs and similar appurtenances, labor for shutting off and turning on sewer or similar items shall be included in the contract price per linear foot of pipe unless otherwise indicated on the bid sheet.
- 17.04 Necessary regulation or operation of valves on existing mains to permit connections to be made will be performed by or with permission of Owner's authorized employees at the Contractor's expense and without extra cost to the Owner.
- 17.05 Carefully support and protect from injury all underground structures and utilities encountered while excavations are in progress or backfilling is being finished as necessary and until proper authorities remove or change same.

#### **PART 18.00 BACKFILLING**

- 18.01 This paragraph applies to backfilling for all types of sewer force main pipes and appurtenances. Where exceptions are specified for certain conditions, they shall govern.
- 18.02 After pipe is laid and as soon as possible after testing, fill trench to surface of ground, and in unimproved streets, place remaining earth on top of trench, as hereinafter specified. If additional backfill material is required, the Contractor shall furnish same without extra cost to the Owner and in sufficient quantity to fill trench to level of surrounding surface after compaction.
- 18.03 Do not leave backfilling unfinished more than 500-feet behind finished pipe work unless otherwise directed.
- 18.04 Do not withdraw sheathing (where used in connection with the work) until trench is sufficiently filled to prevent injury to banks, road surfaces, adjacent pipes, railway tracks, sidewalks and other property, public or private.

Withdraw sheathing in increments of not over 1-foot. Backfill and thoroughly compact voids left by withdrawn sheathing. Except as shown on the drawings or ordered by the Engineer, no sheathing, shoring or bracing shall remain permanently in place.

- 18.05 Leave backfilling in all cases with smooth, rounded surface and with minimum obstruction to traffic.

- 18.06 Compact backfilling solidly around pipes and to distance 6-inches above same in not over 6-inch layers. Make compaction properly so that it causes no lateral movement to the pipe.
- Backfill material shall be selected earth, free of large stones, boulders, trash and foreign matter. Ashes, cinders or other corrosive materials are prohibited.
- 18.07 In refilling trench at intersection streets, fill and solidly compact backfill in roadway for full depth.
- 18.08 If approved by the Engineer, backfill trench with properly compacted, approved, bank-run sand and gravel free from foreign substances and of such consistency that it flows readily into the trench. If this method is used, backfill entire space between sides of trench to the bottom of the pavement base with the same material. Additional payment will be made in accordance with unit price bid for foundation sand.
- 18.09 After backfill has been placed in the trench and before traffic or weathering have hardened the surface, water jet the trench by means of a 2-inch jet running water to the bottom of the trench. Completely wet the entire backfill and break any crust which has inadvertently bridged over the trench. Water jetting will not be required with sand backfill. Water jetting will not be required if trench is less than 5-feet 6-inches (5'6") deep. For trenches less than 5-feet 6-inches (5'6") deep, a good faith effort of compaction must be made. However, a sheep's foot roller is not required.
- 18.10 Regardless of the method of compaction, the Contractor is responsible for correcting settling that may occur during the one-year warranty period.

#### **PART 19.00 RAILROAD CROSSINGS**

- 19.01 Refer to Highway and Railroad Crossings Section and Special Conditions for detailed information regarding requirements.
- 19.02 Unless otherwise shown on the drawings, the average depth of casing of enclosure for pipes (for full length as shown on drawings) crossing under tracks shall be at least 4-feet 6-inches (4'6") below base of rail to top of casing pipe.
- 19.03 Unless otherwise required by the railroad company, lay all water main pipe in enclosing pipe (plain steel casing, corrugated metal pipe or otherwise as shown on the plans) and of sizes shown on drawings or required by the railroad company. Place said enclosing pipe either by jacking method, tunneling or boring. If tunneling method is used, cribbing or shoring shall remain in place. Fill space between cribbing and enclosing pipe with approved, bank-run sand and gravel. Method of placing enclosing pipe is subject to the Engineer's approval before commencing construction thereon.

#### **PART 20.00 HIGHWAY CROSSINGS**

See Highway and Railway Crossings Section and Special Conditions for detailed information regarding requirements.

**PART 21.00 NOTE**

Submission of proposal implies that the Bidder is fully conversant with all of Highway and Railroad Departments requirements, also as to all of State, County, and Township requirements. No extra compensation will be paid on account of Bidder's failure to be so informed.

**PART 22.00 WATER MAINS ADJACENT TO OR CROSSING SEWER LINES**

22.01 HORIZONTAL AND VERTICAL SEPARATION

- A. Lay sewer force main at least 10-feet horizontally from any existing or proposed water line, if possible.
- B. Wherever sewer force mains cross water mains, lay sewer force main at such elevation that bottom of water main is at least 18-inches above top of sewer force main. Maintain said vertical separation for that portion of water main located within 10-feet, horizontally, of any water main crossed; said 10-feet to be measured as normal distance from water main to sewer force main.

22.02 CONSTRUCTION REQUIREMENTS

- A. If impossible to obtain proper horizontal and vertical separation as specified above, then construct both water and sewer of approved mechanical joint ductile iron pipe.
- B. Approved sewer force main pressure pipe can be substituted for mechanical joint ductile iron pipe.

**PART 23.00 TESTING PIPE AND JOINTS IN TRENCHES (ALL TYPES OF PIPES)**

- 23.01 Make tests between valves and as far as practicable in sections of approximately 1000-feet to 2000-feet long, as directed. Make test when possible, within twelve (12) working days of completion of said sections.
- 23.02 To determine rate of leakage, provide suitable pump, pressure gauge, water meter, water container and other appliances for measuring the amount of water pumped. Test these instruments for accuracy as frequently as directed.
- 23.03 Provide all labor and materials necessary to make tests to perform all work incidental thereto. Provide pump to raise pressure to required pressure.
- 23.04 Before applying test, expel all air from pipe. Make taps if necessary at high points of elevation. Afterward, plug same tightly.
- 23.05 Examine carefully, all exposed pipe, fittings, valves, and joints during open trench test. Where mechanical joint or joints made by rubber couplings show visible leaks take them apart, clean and reassemble same, with new parts, as necessary, until no leaks are visible.
  - A. Replace rubber gaskets where necessary to eliminate leaks.

- B. Remove and replace without extra cost to the Owner, all cracked or otherwise defective pipe, fittings, valves and hydrants discovered in consequence of pressure test.
  - C. After making all required repairs and replacements, repeat pressure tests until all work is satisfactory to the Engineer.
- 23.06 After a section of main is installed, partially backfilled and is ready for testing, fill same with water from existing distribution system, or other approved source; then isolate this section from balance of system.
- 23.07 Raise pressure to class specified unless otherwise stipulated. Maintain pressure for period of at least two (2) hours. Make determination of amount of water forced into main during these periods; such amount shall be basis for computing leakage for twenty-four (24) hours. Pressure shall not vary over two pounds (2 lbs.) during said periods.
- 23.08 Compute allowable leakage on basis of 10 gallons per inch of pipe diameter, per mile of length, per twenty-four (24) hours. Pressure shall not vary over two pounds (2 lbs.) during said period. Allowable leakage per one thousand (1,000) linear feet of sewer force main is as follows:

**TOTAL ALLOWABLE LEAKAGE PER  
ONE THOUSAND (1,000) FEET, IN GALLONS**

| <u>DIAMETER<br/>OF PIPE</u><br>(Inches) | <u>IN TWO<br/>(2) HOURS</u> | <u>IN TWENTY-FOUR<br/>(24) HOURS</u> |
|---|-----------------------------|--------------------------------------|
| 2                                       | 0.3                         | 3.8                                  |
| 4                                       | 0.6                         | 7.6                                  |
| 6                                       | 1.0                         | 11.4                                 |
| 8                                       | 1.3                         | 15.2                                 |
| 10                                      | 1.6                         | 18.9                                 |
| 12                                      | 1.9                         | 22.7                                 |
| 14                                      | 2.2                         | 26.5                                 |
| 16                                      | 2.5                         | 30.3                                 |

- 23.09 If leakage is a greater rate than specified in sub-paragraph (23.08) above, re-excavate trench as necessary, replace defective work until leakage is reduced to allowable amount. All costs for labor and materials for said re-excavation, re-caulking pipe, removing defective valves, pipes, or special casting sand replacing same with new valves, pipes and castings, also for refilling trench and replacing any pavement disturbed shall be paid by the Contractor without extra cost to the Owner.
- 23.10 Whenever testing of any main is delayed beyond time specified above, the Engineer may give written notice to the Contractor to make said test forthwith. If the Contractor does not comply with such order within five (5) days from date of same, the Owner may make required test and deduct the cost thereof (including cost of all excavation and other work

required to make pipe, joints, valves, hydrants and other items water-tight) from monies due or to become due to the Contractor under this contract.

- 23.11 Wherever it is impracticable to test between valves or near connections to existing mains, place temporary caps or plugs on mains and test sections of new main so closed. Do such capping or plugging without extra cost to the Owner.

#### **PART 24.00 WATER FOR TESTING**

24.01 If for any reason the Owner is unable to furnish water for testing, flooding or other purposes, the Contractor shall at his own expense, and without extra cost to the Owner, make all connections and other necessary provisions and shall provide all water mains and pipe (all types), hydrants, valves and appurtenances specified herein conform to specifications requirements and of such character as to leave all said pipe and connections watertight.

24.02 When the Owner can conveniently furnish water to the Contractor for flooding trenches, testing pipe, joints and for other purposes, there will be no charge except for labor of shutting off or turning on water. The Owner is in no way obligated to furnish water to the Contractor, with or without charge.

#### **PART 25.00 CLEAN UP AND DAMAGE REPAIR**

25.01 The Contractor shall clean up on a daily basis the waste from the site; provide barriers as required at all times.

25.02 Upon completion of the work, the Contractor shall remove from the sites all construction equipment, unused materials, salvaged materials, and debris resulting from the work.

#### **PART 26.00 GUARANTEE**

26.01 The Contractor shall and hereby does guarantee that all material and work for Sewer Force Main work shall be free from defects of material and labor and shall be and remain in good condition for a period of one (1) year from date of Owner's final acceptance of same.

26.02 The Contractor shall and hereby does further agree that he will, at his own expense and without extra cost to Owner, remove, repair and replace all said defective work occasioned by operations under this section of the specifications which occurs during the one (1) year guaranty period and that he will also make good at his own expense and without extra cost to the Owner any and all damages to other work caused by such repair and replacement operations.

THE FOLLOWING PAGES ARE THE  
END OF SECTION

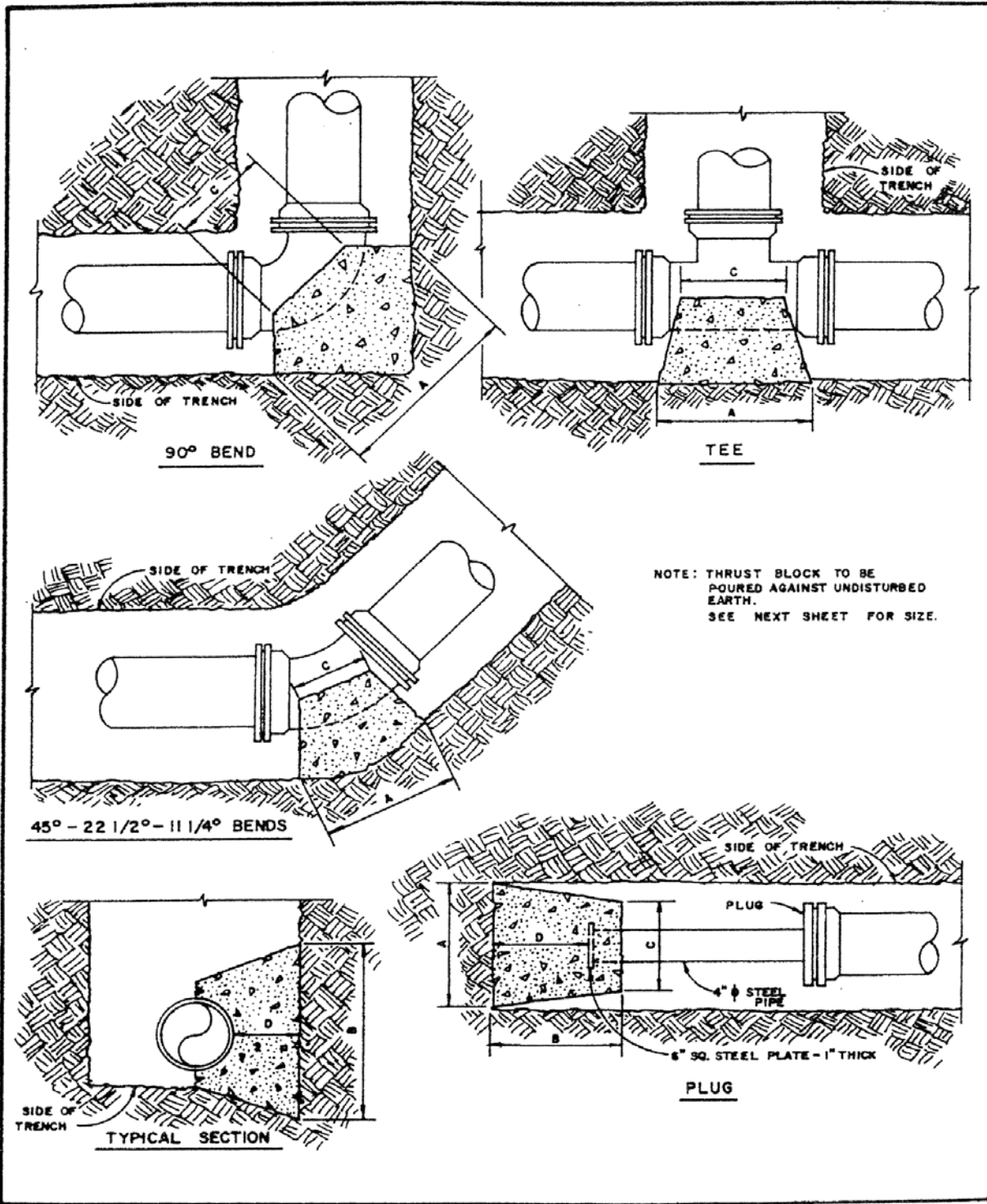

NOTE: THRUST BLOCK TO BE  
POURED AGAINST UNDISTURBED  
EARTH.  
SEE NEXT SHEET FOR SIZE.

|  |          |                            |             |
|--|----------|----------------------------|-------------|
| TENNESSEE<br>PUBLIC WORKS<br>CONSTRUCTION<br>STANDARDS | REVISED: | THRUST BLOCKING<br>DETAILS | DRAWING NO. |
|  |          |                            | TBD<br>1    |

| 90° BEND |     |     |     |     |     |     |     |
|----------|-----|-----|-----|-----|-----|-----|-----|
| SIZE     | 2"  | 4"  | 6"  | 8"  | 10" | 12" | 18" |
| A        | 16" | 16" | 26" | 33" | 40" | 50" | 79" |
| B        | 16" | 16" | 24" | 33" | 40" | 50" | 79" |
| C        | 9"  | 9"  | 12" | 12" | 15" | 16" | 22" |
| D        | 6"  | 3"  | 12" | 16" | 20" | 25" | 24" |

| 45° BEND |     |     |     |     |     |     |     |
|----------|-----|-----|-----|-----|-----|-----|-----|
| SIZE     | 2"  | 4"  | 6"  | 8"  | 10" | 12" | 18" |
| A        | 12" | 12" | 18" | 24" | 31" | 37" | 52" |
| B        | 12" | 12" | 18" | 24" | 31" | 37" | 52" |
| C        | 8"  | 8"  | 10" | 12" | 14" | 16" | 14" |
| D        | 6"  | 6"  | 9"  | 12" | 15" | 18" | 18" |

| 22-1/2° BEND |    |    |     |     |     |     |     |
|--------------|----|----|-----|-----|-----|-----|-----|
| SIZE         | 2" | 4" | 6"  | 8"  | 10" | 12" | 18" |
| A            | 9" | 9" | 13" | 18" | 23" | 26" | 40" |
| B            | 9" | 9" | 13" | 18" | 23" | 26" | 40" |
| C            | 8" | 8" | 10" | 12" | 14" | 16" | 15" |
| D            | 4" | 4" | 6"  | 9"  | 11" | 13" | 16" |

| 11-1/2° BEND |    |    |     |     |     |     |     |
|--------------|----|----|-----|-----|-----|-----|-----|
| SIZE         | 2" | 4" | 6"  | 8"  | 10" | 12" | 18" |
| A            | 9" | 9" | 11" | 13" | 16" | 18" | 30" |
| B            | 9" | 9" | 11" | 13" | 16" | 18" | 30" |
| C            | 8" | 8" | 10" | 12" | 14" | 16" | 15" |
| D            | 4" | 4" | 5"  | 6"  | 8"  | 9"  | 16" |

| TEE    |       |        |        |        |       |       |     |     |
|--------|-------|--------|--------|--------|-------|-------|-----|-----|
| SIZE   | 2"-6" | 3"-12" | 3"-10" | 3"-10" | 2"-6" | 2"-6" | 12" | 18" |
| MAIN   | 2"-6" | 3"-12" | 3"-10" | 3"-10" | 2"-6" | 2"-6" | 12" | 18" |
| BRANCH | 2"-6" | 3"-12" | 3"-10" | 3"-10" | 2"-6" | 2"-6" | 12" | 18" |
| A      | 26"   | 26"    | 43"    | 43"    | 26"   | 26"   | 52" | 70" |
| B      | 26"   | 26"    | 43"    | 43"    | 26"   | 26"   | 52" | 70" |
| C      | 12"   | 12"    | 12"    | 12"    | 12"   | 12"   | 12" | 30" |
| D      | 13"   | 13"    | 21"    | 21"    | 13"   | 13"   | 26" | 24" |

| PLUG |     |     |     |     |     |     |     |
|------|-----|-----|-----|-----|-----|-----|-----|
| SIZE | 2"  | 4"  | 6"  | 8"  | 10" | 12" | 18" |
| A    | 26" | 26" | 26" | 34" | 43" | 52" | 70" |
| B    | 26" | 26" | 26" | 34" | 43" | 52" | 70" |
| C    | 12" | 12" | 12" | 12" | 12" | 12" | 30" |
| D    | 11" | 11" | 11" | 15" | 22" | 32" | 32" |

THRUST BLOCKING DIMENSIONS TBD2



**SECTION 02733.5**  
**PVC FORCE MAIN PIPE**

**PART 1.00 NOTICE**

The General Conditions, Special Conditions and all other herein bound and accompanying documents are part of these Specifications and of the Contract. Submission of proposal implies that the Bidder is fully conversant with all requirements of all said documents.

**PART 2.00 PVC FORCE MAIN**

- 2.01 Pipe must meet all the requirements as set forth in Product Standard PS 22-70 (formerly Commercial Standard CS 256-63) for PVC Type I, Grade 1, PVC 1120 or PVC Type I, Grade 2, PVC 1220 only, with standard dimension ration SDR 26, pressure rating of 160 psi and bearing the National Sanitation Foundation Testing Laboratories, Inc. (NSFTLI), seal of approval.
- 2.02 Provisions must be made for contraction and expansion at each joint with rubber ring, tapered end and bell as integral part of each full joint with standard dimension ration SDR 26 being maintained throughout the entire bell section; a factory welded joint with the bell section meeting the latest Commercial Standard for socket type and shall be same material as set forth above; or Twin Gasket Coupling meeting requirements as set forth above. All fittings such as Tees, Ells, etc., shall be factory welded, meeting the same specifications as the welded bell section. Lubricant shall be of the non-toxic type. Cast iron fittings designed for use with plastic pipe may be used.
- 2.03 Only pipe manufacturers approved by the State Health Department can be used.

END OF SECTION

**SECTION 02733.6.1**  
**PVC GRAVITY SEWER PIPE**

**PART 1.00 NOTICE**

The General Conditions, Special Conditions, and all other herein bound and accompanying documents are part of these Specifications and of the Contract. Submission of proposal implies that the Bidder is fully conversant with all requirements of all above mentioned documents.

**PART 2.00 PVC PIPE**

- 2.01 The pipe shall conform to ASTM Standard Specifications for PVC Sewer Pipe ASTM Designation D-3034, latest revision, except as otherwise specified herein.
- 2.02 The minimum wall thickness for PVC pipe shall conform to standards shown on the chart in Part 10. Pipe lengths shall not be greater than 20-feet.

**PART 3.00 JOINTS**

Flexible gasketed joints shall be compression type with a gasket confined in a machined groove in the spigot end of the pipe. Rubber gasket rings shall conform to the requirements of ASTM D1689. Gaskets shall be neoprene or other synthetic material. Natural rubber gaskets will not be acceptable.

**PART 4.00 FITTINGS**

Fittings defined as tee connections suitable for assembly to 4-inch or 6-inch house or buildings sewers shall be injection molded fittings of PVC plastic.

**PART 5.00 INSTALLATION**

The pipe shall be installed in accordance with ASTM Standard Recommended Practice for Underground Installation of Flexible Thermoplastic Sewer Pipe, ASTM Designation D-2321, latest revision.

**PART 6.00 BEDDING REQUIREMENTS**

PVC sewer pipe shall be bedded with Class A or Class B aggregate as specified in Section 903.05 of the Standard Specifications for Road and Bridge Construction, Tennessee Department of Transportation; March 1, 1995. Class A or Class B aggregate shall be used in lieu of those aggregates as described in ASTM-2321-74. Cost of bedding shall be included in other items bid. No additional payment will be made for bedding.

**PART 7.00 ALIGNMENT AND DEFLECTION**

Upon completion of backfilling and street repair, checks for alignment and tests for deflection shall be conducted by the Contractor. A deflection of more than five percent (5%) of the inside

diameter shall be cause for rejection and the line will be removed and replaced at the Contractor's expense. Deflection Testing Mandrell shall be used for determining deflection of plastic pipe 8-inches and above in size. See Standard Sewer Detail Sheet in Plans. Test shall be conducted at least 24-hours after backfilling.

**PART 8.00 CONNECTION TO MANHOLE**

Gravity sewer pipe shall be connected to the manhole by a flexible connector. Sleeve material shall be high quality polyisoprene rubber with 304 stainless steel straps as manufactured by PSX Press-Seal Gasket Corp. or equal. Couplings shall be flexible, water and airtight.

**PART 9.00 CONNECTION TO OTHER TYPES OF SEWERS**

Where PVC sewer pipe is used to connect house services to sewer mains of a different material (clay, concrete, etc.) special fittings manufactured to satisfy the situation must be used. A sturdy watertight connection must be achieved. Also pipe of different material or sizes shall be connected by means of neoprene rubber couplings as manufactured by Fernco or approved equal.

**PART 10.00 STANDARD WALL THICKNESS POLYVINYL CHLORIDE PIPE**

**STANDARD WALL THICKNESS  
POLYVINYL CHLORIDE PIPE**

**WALL THICKNESSES BY PIPE CLASSIFICATION**

| <u>PIPE SIZE</u> | <u>SDR 26</u> |
|------------------|---------------|
| 4"               | .173          |
| 6"               | .255          |
| 8"               | .332          |
| 10"              | .413          |
| 12"              | .490          |
| 16"              | .615          |

**SANITARY SEWER PIPE  
SELECTION CRITERIA**

|              |  |
|--------------|--|
| 0' – 3'      | Cover Use Ductile Iron Pipe              |
| 3' – 26'     | Cover Use SDR 26 Sewer Pipe and Fittings |
| 26' and Over | Use Ductile Iron Pipe                    |

END OF SECTION

## **SECTION 02740.1 MANHOLES**

### **PART 1.00 NOTICE**

The General Conditions, Special Conditions and all other herein bound and accompanying documents are part of these Specifications and of the Contract. Submission of proposal implies that the Bidder is fully conversant with all requirements of all above-mentioned documents.

### **PART 2.00 SCOPE OF THE WORK**

The work in this section consists of furnishing all materials, accessories, equipment, tools, transportation, services and performance of all operations required to execute the manholes work this project, all as shown and detailed on the drawings, approved shop drawings and as herein specified.

### **PART 3.00 SHOP DRAWINGS**

Before commencing work, submit for the Engineer's approval shop drawings and illustrations as required for manholes work and appurtenances. Refer to the General Conditions for detailed information regarding shop drawings requirements.

### **PART 4.00 JOB CONDITIONS**

Refer to the General Conditions for detailed information regarding job conditions.

### **PART 5.00 GENERAL**

- 5.01 Build manholes as shown on drawings, of concrete sectional rings, concrete cast in place, subject to Engineer's approval.
  - A. Where a particular type of manhole is noted on the drawings as being required, no substitution will be permitted. Otherwise, the Contractor may provide any type herein specified and shown on the drawings, subject to the Engineer's approval.
  - B. Provide all manholes with concrete base, cast iron manhole steps or reinforced plastic manhole steps, cast iron manhole frame and cover and all other accessories and items as shown on the drawings and as conditions require.
- 5.02 Manholes should be installed at distances not greater than 350-feet for sewers 15-inches in diameter or less; 400-feet for sewers 18-inches and 21-inches in diameter; and 500-feet for sewers 24-inches and over in diameter.
- 5.03 Drop pipe shall be provided for a sewer entering a manhole at an elevation of 24-inches or more above the manhole invert.

## **PART 6.00 EXCAVATION AND BACKFILL**

- 6.01 Except as noted below, excavation and backfill for sewer manholes shall conform to requirements of excavation and backfill for sewers and excavation and backfill for water mains.
- A. Do not backfill around manholes until all concrete and mortar have been placed at least twenty-four (24) hours.
  - B. Remove all lumber, braces, rubbish, bricks and other unsuitable backfill material as directed from excavation. Backfill with approved material from the excavation except where special backfill material is shown on the drawings.
  - C. Do all backfilling and compacting carefully. Avoid damage to manhole structures.

## **PART 7.00 MATERIALS**

- 7.01 All materials shall be subject to the Engineer's approval. Refer to General Conditions for detailed information regarding delivery and storage of materials.
- A. All Portland cement, fine and coarse aggregate, steel reinforcement and water shall conform to all applicable requirements for said materials as specified in the Concrete Section.
    - 1) Mortar materials (Portland cement, sand and water) shall conform to ASTM C270, latest revision.
  - B. Concrete sectional rings shall be standard reinforced concrete pipe pattern. Minimum thicknesses shall be 4½-inches for 42-inch manhole, 5-inches for 48-inch manhole. Sectional rings shall be tongue and groove type. Sectional ring manholes shall conform to ASTM C478, latest revision except that circumferential reinforcement shall be not less than 0.14 square inches per lineal foot of barrel. Concrete for sectional rings shall be Class A as specified in the Concrete Section. The manufacturer is to supply certified test results showing compliances with concrete strength requirements. Absorption requirements are not to exceed those specified in sub-paragraph (b) for segmental block. Provide special sectional rings with openings for manhole steps. Exterior of manholes shall be coated with a bituminous seal coat in accordance with AWWA C104-74, Section 4-14, latest revision.
  - C. All mortar for manholes shall be composed of one (1) volume approved Portland cement, two (2) volumes of clean washed, mason's sand and slaked lime putty not in excess of fifteen percent (15%) of volume of cement. Proportion ingredients by measuring. Add water, and mix thoroughly until mortar is of proper consistency, color uniform and mass homogeneous. Transit mixed mortar may be used provided it conforms to specifications requirements, subject to the Engineer's approval. Mortar shall conform to all applicable requirements of ASTM C270,

including materials, mixing, heating (in cold weather). Mixing equipment and trucks shall be clean and free of hardened mortar, ice, water and lumps when dry ingredients are placed inside. Retempering of mortar and addition of admixtures, accelerators and anti-freeze compounds are prohibited. Mix only sufficient mortar at any one time as can be used immediately. Mortar which has been mixed more than forty (40) minutes or which has developed initial set is not acceptable. Remove same immediately from the work site.

- D. Concrete bases for manholes shall be Class A concrete and comply with all requirements of the Concrete Section. Minimum thickness shall be 6-inches. Invert of manhole base shall be filled and shaped as shown on the drawings with Class C concrete.
- E. Concrete base for precast manholes shall be Class A concrete complying with all the requirements of the Concrete Section. The minimum thickness of the base shall be 8-inches on firm ground. The first section of the precast manhole shall then be set so as to be imbedded, 1-inch in the concrete base just poured. Where adverse (wet, spongy, soft or unstable) soil conditions are encountered in the base of the manhole, a sub-base of poured-in-place concrete or crushed stone shall be placed under the 8-inch concrete base. Base shall extend 6-inches beyond outside of manhole.

#### **PART 8.00 CAST IRON COVERS, FRAMES AND STEPS**

- 8.01 All castings shall be sound, smooth, clean, tough, close grained gray iron, free from blow holes, shrinkage, cold shuts, blisters and all defects. All castings shall be of weights, styles, dimensions and conforming in all respects to catalog numbers noted on drawings. Frames and covers shall be true to pattern, with their component parts fitted together in an approved manner, non-rocking design, with machined bearing surfaces which shall seat evenly into frames and prevent rocking, rattling and displacement under traffic. To attain shop finish, clean thoroughly and apply one (1) coat approved tar pitch varnish. All materials shall conform to current revisions of applicable ASTM, AASHTO, AMS, MIL and Federal Specifications, equal to Vulcan 1482-1 or Clow No. F- 3240 Type 2. On the cover of each manhole top shall be cast "SEWER" for sanitary sewer manholes, "DRAIN" for storm sewers manholes, and "WATER" for waterworks manholes.
- 8.02 Provide each standard manhole with one (1) cast iron frame. Except as otherwise shown on the drawings, manhole frames and covers for standard manholes shall have clear opening diameter of at least 22-inches, with base ring of 31-inches nominal diameter. Height shall be 7-inches.
- 8.03 Provide cast iron manhole steps as shown on drawings for each manhole with at least 10-inch wide treads and 5-inch projection. Weight (each) shall be at least ten pounds (10 lbs.), similar and equal to City of Memphis standard or Clow F-3650. Thoroughly clean manhole steps in shop, then coat with coal tar pitch varnish.

**PART 9.00 INSTALLATION, MANHOLE COVERS, FRAMES AND STEPS**

- 9.01 Set manhole frames and covers to lines and grades established therefore in paved street. Top of ring shall be flush with pavement surface. On unpaved streets and on rights-of-way, set ring 1-inch above finished grade unless otherwise directed.
- 9.02 Set manhole steps in masonry with top step 24-inches below top of manhole ring. Set balance of steps on 16-inch centers (for total depth of new work), unless otherwise shown on drawings or directed.

END OF SECTION

**SECTION 02905.1  
SEEDING AND LANDSCAPING**

**PART 1.00 GENERAL**

The General Conditions, Special Conditions and all other herein bound and accompanying documents are part of these specifications and of the Contract. Submission of proposal implies that the Bidder is fully conversant with all requirements of all said documents.

**PART 2.00 SCOPE OF WORK**

2.01 This work shall consist of furnishing and placing seed, plant material, commercial fertilizer, agricultural limestone, and/or mulch material, and of caring for such areas until acceptance, all in accordance with these Specifications.

**PART 3.00 MATERIALS AND EQUIPMENT**

3.01 EQUIPMENT:

Except in areas where it is not practical to do so all work shall be done by machines which will deliver uniform quantities of materials on uniform areas of the ground surface.

3.02 GRASS SEED:

- A. The seed shall meet the requirements of the Tennessee Department of Agriculture and no "Below Standard" seed will be accepted. Grass seed furnished under these Specifications shall be packed in new bags or bags that are sound and not mended.
- B. The Contractor shall furnish the Owner a certified laboratory report from an accredited commercial seed laboratory or from a State seed laboratory showing the analysis of the seed to be furnished and approving the seed for purity and germination. The report from an accredited commercial seed laboratory shall be signed by a Senior Member of the Society of Commercial Seed Technologists. At the discretion of the Engineer, samples of the seed may be taken for a check against the certified laboratory report. Sampling and testing will be in accordance with the requirements of the Tennessee Department of Agriculture.
- C. When a seed group is used, the percentages forming the group shall be as set out below, unless otherwise specified.

|             |                                    |
|-------------|------------------------------------|
| <u>NAME</u> | <u>QUANTITY, PERCENT BY WEIGHT</u> |
|-------------|------------------------------------|

Group A: To be sowed between February 1 and August 1

|                              |    |
|------------------------------|----|
| Lespedeza (Common or Korean) | 20 |
| Sericea Lespedeza            | 15 |
| Ky. 31 Fescue                | 40 |
| English Rye                  | 15 |



| <u>NAME</u>   | <u>QUANTITY, PERCENT BY WEIGHT</u> |
|---|------------------------------------|
| White Dutch Clover  | 5                                  |
| Unhulled Bermuda  | 5                                  |
| Group B: To be sowed between August 1 and December 1                            |                                    |
| Ky. 31 Fescue   | 60                                 |
| Redtop  | 15                                 |
| English Rye   | 20                                 |
| White Dutch Clover  | 5                                  |
| Group C: To be sowed on rocky hard types of soil only if directed by the Owner. |                                    |
| Sericea Lespedeza   | 50                                 |
| KY. 31 Fescue   | 30                                 |
| English Rye   | 15                                 |
| White Dutch Clover  | 5                                  |

In mixing or forming "Groups" of seed, they shall be uniformly mixed. "Group" seed shall not be mixed until after each type seed that is used to form the "Group" has been tested and inspected separately and approved for purity and germination. Seed mixed before tests and inspection are made will not be accepted.

3.03 FERTILIZER:

Manufactured fertilizer shall be a standard commercial fertilizer containing the specified percentages by weight of nitrogen (N), phosphoric acid (P<sub>2</sub>O<sub>5</sub>) and Potash (K<sub>2</sub>O). The fertilizer shall be furnished in standard containers with the name, weight, and guaranteed analysis of the contents clearly marked. The containers shall insure proper protection in handling and transporting the fertilizer. All commercial fertilizer shall comply with Local, State, and Federal fertilizer laws. Fertilizer may be supplied in bulk if a responsible source of supply is identified and a certification is supplied by the supplier stating the quality of the fertilizer.

3.04 AGRICULTURAL LIMESTONE:

Agricultural limestone shall contain not less than eighty-five percent (85%) of calcium carbonate and magnesium carbonate combined and shall be crushed so that at least 85 percent (85%) will pass the NO. 10 mesh sieve and 100 percent (100%) will pass the 3/8-inch sieve.

3.05 MULCH MATERIAL:

- A. All mulch material shall be air dried and virtually free of noxious weeds and weed seeds or other materials detrimental to plant growth on the work site or on adjacent agricultural lands. Hay shall be stalks of approved grasses, sedges, or

legumes seasoned before bailing or loading. Straw shall be stalks of rye, oats, wheat, or other approved grain crops. Both hay and straw shall be suitable for spreading with standard mulch blower equipment. Biodegradable fabric may be used as an alternate to mulch material at the Contractor's option.

- B. If hay is used, the type of hay along with a sample of the material shall be named and submitted for approval in time for expert review before work is to begin.

#### 3.06 INOCULANTS FOR LEGUMES:

Inoculants for treating legume seed shall be standard cultures of nitrogen-fixing bacteria that are adapted to the particular kind of seed to be treated. The inoculants shall be supplied in convenient containers of a size sufficient to treat the amount of seed to be planted. The label on the container shall indicate the specified legume seed to be inoculated and the date period to be used.

#### 3.07 WATER:

Water shall be free from any harmful or objectionable qualities or organisms. Seeded area shall be watered until a stand of grass is obtained. Watering shall be done after 4:00 P.M. or between 5:00 A.M. and 10:00 A.M.

### **PART 4.00 CONSTRUCTION REQUIREMENTS**

#### 4.01 GENERAL:

The Contractor shall notify the Owner at least 48 hours in advance of the time he intends to begin sowing seed and shall not proceed with such work until permission to do so has been granted by the Engineer. Before starting seeding operations on any area, final dressing shall have been completed in accordance with the project requirements. All seeding and related operations shall be continuous operations.

#### 4.02 WEATHER LIMITATIONS:

- A. Plant material shall not be installed between December 1 and February 1, unless weather and soil conditions are considered favorable and permission is granted by the Engineer.
- B. Group "A" and Group "B" seed shall be used for seeding at times specified above. Either Group "A" or "B" may be used during the month of August. Group "C" seed shall be used only when specified on the Plans or in the Contract Documents. No seeding shall be performed between December 1 and February 1, unless otherwise permitted. Seeding shall be performed only when the soil is in a tillable and workable condition.

#### 4.03 PREPARING THE SEEDBED:

Each area to be seeded shall be scarified, disced, harrowed, raked, or otherwise worked until it has been loosened and pulverized to a depth of not less than 3-inches. This

operation shall be performed only when the soil is in a tillable and workable condition. Fertilizer, at the rate of not less than 10 pounds of Grade 24-12-12 or equivalent, per 1,000 square feet, and agricultural limestone, at the rate of not less than 100 pounds per 1,000 square feet, shall be distributed evenly over the seedbed, unless other rates are specified on the Plans or in the contract documents. The limestone and fertilizer shall be lightly harrowed, raked, or otherwise incorporated into the soil for a depth of approximately 1/2-inch. Fertilizer need not be incorporated in the soil as specified above when mixed with seed in water and applied with power sprayer equipment.

#### 4.04 SEEDING:

Seed of the specified group shall be sown as soon as preparation of the seedbed has been completed and thoroughly watered after seeding. Care shall be exercised to not wash seeding by over-watering. Seed shall be sown uniformly by means of a rotary seeder, wheelbarrow seeders, hydraulic equipment, or other satisfactory means, and unless otherwise specified on the Plans or in the Contract Documents, at the rate of 2 pounds per 1,000 square feet. Seeds of legumes when sown alone shall be inoculated before sowing in accordance with the recommendations of the manufacturer of the inoculant and as directed by the Engineer. No seeding shall be done during windy weather, or when the ground surface is frozen, wet, or otherwise non-tillable. If Bermuda seed only is used, roll or harrow 60 pounds per acre to 1/4-inch depth.

#### 4.05 MULCHING:

- A. When seeding with mulch, the mulch material shall be spread evenly over the seeded areas at an approximate rate of 75 pounds per 1,000 square feet immediately following the seeding operations. This rate may be varied by the Engineer, depending on the texture and condition of the mulch material and the characteristics of the area seeded. All portions of the seeded areas shall be covered with a uniform layer of mulch, so that approximately 25 percent (25%) of the ground is visible.
- B. The mulch shall be held in place by the use of an approved mulch binder. Cutback asphalt, Grade SS-1 or emulsified asphalt shall be applied at the approximate rate of 2 gallons per 1,000 square feet or more as required to hold the mulch in place. Mulch in medians and other areas affected by traffic shall be held in place by applying asphalt binder at the approximate rate of 7 gallons per MSF.
- C. The Contractor shall cover exposed structures, guardrails, signs, and appurtenances, if the mulch binder is applied in such a way, that it would come in contact with or discolor the structures. All mulching shall be done by machine, except in small areas where machine usage are impractical. No materials shall be sprayed on or allowed to drift on walls and/or walks.

END OF SECTION

## **SECTION 03001 CONCRETE**

### **PART 1.00 NOTICE**

The General Conditions, Special Conditions and all other herein bound and accompanying documents are part of these Specifications and of the Contract. Submission of proposal implies that the Bidder is fully conversant with all requirements of all above mentioned documents.

### **PART 2.00 SCOPE OF WORK**

Work covered by this section consists of furnishing all plant, labor, equipment, appliances and material and in performing all operations in connection with the installation of concrete work complete, in strict accordance with this section of the specifications and applicable drawings and subject to the terms and conditions of the contract.

### **PART 3.00 APPLICABLE SPECIFICATIONS**

The Standard Specifications of the American Society for Testing and Materials (ASTM) and the American Concrete Institute (ACI) as they appear herein or on the Plans by reference form a part of this specification.

### **PART 4.00 SHOP DRAWINGS**

Submit for the Engineer's review complete shop drawings for all reinforcing steel required for this project. Refer to the General Conditions for detailed information regarding shop drawings requirements. Detail wall reinforcement in elevation views and slab reinforcement in plan views.

### **PART 5.00 GENERAL**

Full cooperation shall be given other trades to install embedded items. Suitable templates or instructions or both will be provided for setting items in place in the forms. Embedded items shall have been inspected and tests for concrete or other materials or for mechanical operation shall have been completed and approved before concrete is placed.

### **PART 6.00 JOB CONDITIONS**

Refer to the General Conditions for detailed information regarding job conditions requirements.

### **PART 7.00 MATERIALS**

7.01 Ready-mix concrete shall be used. Ready mixed concrete shall conform to ASTM Standard C94, latest revision. Submit proposed mix designs, tested per ACI 350 or ACI 318, a minimum of thirty (30) days prior to concrete placement for engineer's review. Type II cement shall be used for all tanks and basins.

7.02 CURING MATERIALS:

- A. Waterproof Paper - ASTM C171, latest revision, Type I.
- B. Membrane Curing Compound - ASTM C309, latest revision, Type I.

7.03 Expansion joints shall be premolded, and shall conform to ASTM D1751, latest revision.

7.04 Dumbbell water stops shall be vertical and horizontal, of required types, shapes, sizes as indicated, (Neoprene Rubber). Provide corner and "L" members (flat or horizontal), tees, unions, and split dumbbell. Install per the manufacturer's printed instructions in all joints of liquid containment structures.

7.05 Joint sealer shall be cold application type or hot poured elastic type as approved by the Engineer. Concrete joint sealer cold application type shall conform to ASTM D1850, latest revision. Concrete joint sealer, hot poured elastic type, shall conform to ASTM D1854, latest revision.

7.06 Forms shall be wood, metal or other approved material and shall conform to the following requirements:

A. WOOD:

- 1. Unexposed Concrete Surfaces - No. 2 common or better lumber.
- 2. Exposed Concrete Surfaces - dressed and matched boards of uniform thickness of a width not exceeding 10-inches, or plywood.

7.07 Form ties shall be suitable for the purpose of the structure. In liquid containment structures, the portions of single rod ties that remain in the wall shall be provided with an integral waterstop at mid point. The assembly shall provide cone shaped depressions at the surface, at least 1-inch in diameter and 1½ -inches deep, to allow filling and patching.

Through ties that are to be entirely removed shall be tapered over the portion that passes through the concrete. The large end shall be on the liquid side of the wall.

All tie depressions and/or holes shall be filled. The Contractor shall demonstrate and submit for review the methods and materials used for filling the voids formed by the ties. Filling material shall be non-shrink.

7.08 FORM OIL:

Commercial quality, colorless, mineral oil, free of kerosene and of a viscosity suitable for the intended use.

7.09 REINFORCEMENT:

See Structural drawings.

**PART 8.00 CLASSES OF CONCRETE AND USAGE**

8.01 See table below for requirements of strength, maximum water cement ratio, and slump. Concrete of the various classes required shall be proportioned in such manner to give the following tabulated minimum strength and shall not exceed the listed maximum water cement ratios shown.

| <u>Class of Concrete</u> | <u>Compressive Strength<br/>PSI at 28 Days</u> | <u>Maximum Water Cement Ration<br/>Gal/Bag</u> | <u>Slump</u> | <u>Coarse Aggregate<br/>(1½" Max.)</u> |
|--------------------------|--|--|--------------|--|
| Class A                  | 4000   | 0.48   | 4"           | Limestone                              |
| Class C                  | 3000   | 0.59   | 8"           | Contractor's Option                    |

8.02 USAGES:

Concrete of the various classes shall be used as follows:

A. Class A Concrete:

For general concrete work, including all steel reinforced structural elements of buildings, tanks and appurtenant structures, slabs, on grade and sidewalks.

B. Class C Concrete:

For all concrete not reinforced including fill concrete in hydraulic structures.

**PART 9.00 AIR-ENTRAINED CONCRETE**

9.01 Unless otherwise stated, all structures and all concrete exposed to the weather shall be air-entrained.

9.02 Total air content shall be 4½% for 1-inch and 1½-inch aggregates, and 5% for ¾-inch aggregate, with a tolerance of ± 1½%.

9.03 All equipment and labor necessary to determine air content of the concrete shall be furnished by the Contractor. If the Contractor is unable to perform the test, then the Contractor shall coordinate with a Testing Laboratory to perform the necessary tests.

**PART 10.00 TESTS**

10.01 The Owner shall, as part of this Contract, pay costs of all laboratory and other tests. Contractor shall be responsible for taking cylinders and for notifying Testing Lab when their services are required. At least one (1) sample shall be taken consisting of three (3) cylinders for each twenty-five (25) cubic yards or a minimum of one (1) sample per day. Testing shall be as follows:

One (1) seven (7) days in laboratory.

One (1) twenty-eight (28) days in laboratory (hold as reserve).

One (1) twenty-eight (28) days in laboratory.

10.02 Cylinders shall be properly identified as to placement location of the concrete sampled and cured in the field until the Testing Laboratory takes possession of the cylinders. Cylinders should be covered with damp burlap until initial set occurs. Once initial set occurs, the cylinders should be immersed in water, which is similar to the process used by Testing Laboratories.

### **PART 11.00 REMOVAL OF FORMS**

11.01 Wall and column forms shall remain in place a minimum of seven (7) days. During this time, the forms shall be kept wet. Other forms may be removed at any time that removal does not cause damage to the slab edges. The forms shall be removed carefully so as to avoid damage to the concrete. After the forms have been removed, the sides shall be cured as outlined in one of the methods indicated below. Major honeycombed areas will be considered as defective work, and all unsound material shall be removed and replaced with satisfactory material at the Contractor's expense.

11.02 Remove from work carefully, without using wrecking tools or crowbars directly against concrete. The Contractor shall make good at his own expense, without extra cost to the Owner, all damages to concrete and building occasioned by removal of forms and shores. No wood forms shall remain in place.

### **PART 12.00 CURING**

12.01 In all cases in which curing requires the use of water, the curing shall have prior right to all water supply or supplies. Failure to provide a sufficient quantity of one of the curing materials or lack of water to adequately take care of both curing and other requirements shall be cause for immediate suspension of concreting operations. The concrete shall not be left exposed for more than one-half (½) hour between stages of curing or during the curing period. Immediately after the finishing operations have been completed and as soon as marring of the concrete will not occur, the entire surface of the newly placed concrete shall be covered and cured in accordance with one of the following methods:

A. **COTTON OR BURLAP MATS:**

The surface of the slab shall be entirely covered with mats. The mats used shall be of such length (or width) that, as laid, they will extend at least twice the thickness of the pavement beyond the edges of the slab. The mats shall be placed so that the entire surface and both edges of the slab are completely covered. Prior to being placed, the mats shall be saturated thoroughly with water. The mats shall be so placed and weighted down as to cause them to remain in intimate contact with the surface covered, and the covering shall be maintained fully wetted and in position for seventy-two (72) hours after the concrete has been placed or the forms have been removed unless otherwise specified.

**B. IMPERVIOUS MEMBRANE METHOD:**

1. The entire surface of the slab or wall shall be sprayed uniformly with white pigmented curing compound immediately after the finishing of the surface and before the set of the concrete has taken place, or if the slab or wall is cured initially with jute or cotton mats, it may be applied upon removal of the mats. The curing compound shall not be applied during rainfall.
2. Curing compound shall be applied under pressure by mechanical sprayers at the rate recommended by the manufacturer but in no case at a rate less than one (1) gallon to each 150 square feet. The spraying equipment shall be of the fully atomizing type equipped with a tank agitator. At the time of use, the compound shall be in a thoroughly mixed condition with the pigment uniformly dispersed throughout the vehicle. During application, the compound shall be stirred continuously by effective mechanical means. Hand spraying of odd widths or shapes will be permitted. Curing compound shall not be applied to the inside faces of joints to be sealed. Should the film become damaged, portions shall be repaired immediately with additional compound.
3. Upon removal of side forms, the sides of the slabs exposed shall be protected immediately by applying curing treatment equal to that provided for the surface.

**C. WHITE POLYETHYLENE SHEETING:**

The top surface and sides of the slab or wall shall be entirely covered with polyethylene sheeting. The units used shall be lapped at least 18-inches. The sheeting shall be so placed and weighted down as to cause it to remain in intimate contact with the surface covered. The sheeting, as prepared for use, shall have such dimension that each unit as laid will extend beyond the edges of the slab at least twice the thickness of the pavement. The surface of the slab or wall shall be thoroughly wetted prior to placing the sheeting. Unless, otherwise specified, the covering shall be maintained in place for seventy-two (72) hours after the concrete has been placed.

**D. REQUIREMENTS:**

1. For requirements for cold weather concreting, comply with ACI 306, "Cold Weather Concreting", latest edition.
2. For requirements for hot weather concreting, comply with ACI 305, "Hot Weather Concreting", latest edition.
3. Copies of the above publications shall be obtained by the Contractor and kept on the jobsite for reference.



### **PART 13.00 FINISHES OF CONCRETE OTHER THAN SLABS**

- 13.01 Immediately after removal of the forms, all fins and loose materials shall be removed; honeycomb aggregate pockets, voids and holes of ½-half-inch in diameter or greater shall be cut out to solid concrete or to the limits defined by the Engineer and patched with an approved patching material.
- 13.02 The surfaces shall be rubbed with a carborundum brick and watered to produce a uniform plane surface free from form marks and other blemishes. Cement mortar or grout shall not be added to the surface during the rubbing operation. Particular care shall be exercised to preserve chamfer lines, mouldings and other treatments at the intersection of two (2) plane or curved surfaces.
- 13.03 In the event that the Contractor elects to use membrane curing compound, all patchwork noted above shall be completed within one (1) day after removal of forms and before application of curing compound.

### **PART 14.00 CONCRETE SLAB FINISHES**

- 14.01 Finished slab surfaces shall be true plane surfaces with a tolerance of 1/8-inch in 10-feet, unless otherwise indicated on the drawings. The dusting of finished surfaces with dry cement will not be permitted. All slab surfaces shall be monolithic finish produced as follows:
- A. Immediately after placing the concrete, the surface of the slab shall be screeded and floated with highway straight edges to bring the surface to the required finish level. While the concrete is still green, but sufficiently hardened to bear a man's weight without deep imprint, it shall be wood floated to a true, even plane with no coarse aggregate visible. After surface moisture has disappeared, surface shall again be wood floated to a smooth even finish, free from float and shall then be followed by a light coverage with a steel trowel.

### **PART 15.00 FINISHES FOR CONCRETE SIDEWALK AND DRIVEWAY**

Concrete sidewalk and driveway shall be finished true to sections shown on the drawings as specified for concrete slab finished except that the final coverage with steel trowel shall be replaced by a light brushing with a stiff bristled brush.

END OF SECTION

**SECTION 13001.2  
HORIZONTAL DIRECTIONAL DRILLING  
FOR RESTRAINED PIPE  
C900/RJ or C905/RJ**

**PART 1 GENERAL**

**WORK INCLUDED**

- A. Furnish all labor, materials and equipment required to install (Pipe Size) potable water main, reclaimed main and force main pipe using directional drilling method of installation, all in accordance with the requirements of the Contract Documents. The pipe size, type and length shall be as specified herein and as shown on the Drawings. Work shall include and not be limited to proper installation, testing, restoration of underground utilities and environmental protection and restoration.

This specification covers the use of different types of restrained pipe. See SPECIAL CONDITIONS for the specific pipe to be used on this project.

- B. The directional drill shall be accomplished by first drilling a pilot hole as shown on the approved pilot bore plan, and then enlarging the pilot hole no larger than 1.5 times the outer diameter of the Certa-Lok C900 / RJ coupling to accommodate the pull back of the pipe through the enlarged hole.

**REFERENCE SPECIFICATIONS, CODES AND STANDARDS  
CERTAINTeed - CERTA-LOK C900 AND C905 (16")/ RESTRAINED JOINT PIPE**

**1.0 SCOPE**

This specification covers thrust-restrained Poly-Vinyl Chloride (PVC) pipe, in nominal sizes 4" – 16" with cast iron pipe outside diameters. Pipe is included for use as a pressure-rated water delivery system, reclaimed water system, as well as in sewer force main and fire protection piping applications or as a casing for small diameter pipe.

**2.0 REFERENCE DOCUMENTS**

American Society for Testing Materials (ASTM)14

ASTM D1784: Standard for Rigid PVC Compounds and Chlorinated PVC Compounds

ASTM D2837: Standard Test Method for Obtaining Hydrostatic Design Basis for Thermoplastic Pipe Materials

ASTM D3139: Standard Specification for Joints for Plastic Pipes Using Flexible Elastomeric Seals

ASTM F477: Standard Specification for Elastomeric Seals (Gaskets) for Joining Plastic Pipe

American Water Works Association (AWWA)

AWWA C900/C905: Standard for PVC Pressure Pipe Fabricated Fittings, 4" Through 16", for Water Distribution

National Sanitation Foundation (NSF)

NSF14: Plastic Pipe System Components and Related Materials

NSF61 Drinking Water System Components – Health Effects

Underwriters Laboratories (UL)

Quick burst test

Million cycle test

1000 hour sustained pressure test

Deflection leakage test

Factory Mutual Research (FM)

Underground fire protection approval

3.0 REQUIREMENTS

3.1 GENERAL:

Products delivered under this specification shall be manufactured only from new water distribution pipe and couplings, conforming to AWWA C900/C905. The restrained joint pipe shall also meet all AWWA C900/C905 short-term pressure test requirements. Pipe, couplings, and all locking splines components used thereon shall be completely non-metallic to eliminate corrosion problems.

3.2 MATERIALS:

Pipe and couplings shall be made from unplasticized PVC compounds having a minimum cell classification of 12454-B, as defined in ASTM D1784. The compound shall qualify for a Hydrostatic Design Basis (HDB) of 4000 psi for water at 73.4 Degrees F, in accordance with the requirements of ASTM D2837.

3.3 APPROVALS:

Restrained joint pipe products shall be tested and approved by an independent third-party laboratory for continuous use at rated pressure. Copies of Agency approval reports or product listing shall be provided to the ENGINEER. Products intended for contact with potable water shall be evaluated, tested, and certified for conformance with NSF Standard 61 by an acceptable certifying organization.

3.4 DIMENSIONS:

Nominal outside diameters and wall thicknesses of thrust-restrained pipe shall conform to the requirements of AWWA C900/C905. Thrust-restrained pipe shall be furnished in sizes 4", 6", 8", 10", 12" and 16", Class 150 and Class 200. Pipe shall be furnished in standard lengths of 20-

feet. Dimensions of the pipe thrust restraint grooves shall be in accordance with manufacturer's specifications.

### 3.5 JOINTS:

The pipe shall be joined using non-metallic couplings, which have been designed as an integral system for maximum reliability and interchangeability. High-strength flexible thermoplastic splines shall be inserted into mated, precision-machined grooves in the pipe and coupling to provide joint restraint with evenly distributed loading.

Couplings shall be designed for use at the rated pressure of the pipe with which they are utilized, and shall incorporate twin elastomeric sealing gaskets meeting the requirements of ASTM F477. Joints shall be designed to meet the leakage test requirements of ASTM D3139 or the Owner's requirements whichever is more stringent.

### 3.6 QUALITY CONTROL:

Every pipe and machined coupling shall pass AWWA C900 hydrostatic proof test requirements (4X rated pressure for 5 seconds).

### 3.7 MARKING:

Pipe shall be legibly and permanently marked in ink with the following information.

- Manufacturer and Trade Name
- Nominal Size & DR Rating/Pressure Class
- Hydrostatic Proof Test Pressure
- NSF-61
- Manufacturing Date Code
- AWWA C-900/C905

Pipe and couplings shall bear the mark of the certifying agency(s), which have tested and approved the product for use in fire protection applications.

### 3.8 WORKMANSHIP:

As defined in AWWA C900/C905, pipe and couplings shall be homogeneous throughout and free from voids, cracks, inclusions, and other defects, and shall be as uniform as commercially practicable in color, density, and other physical characteristics.

### 4.0 QUALITY OF PIPE

Restrained Joint PVC Pipe shall be equal to CertainTeed's Certa-Lok System.

## **PART 2 PRODUCTS**

### POLYVINYL CHLORIDE (PVC) PIPE

- A. The pipe material to be used shall meet AWWA C900/C905 standards for Polyvinyl Chloride pressure pipe and fittings with a dimension ratio DR18. PVC pipe that is intended for use as a casing for a finished product pipe may have the dimension ratio of 18. The pipe shall be designated as Certa-Lok as manufactured by CertainTeed Corporation.
- B. The pipe shall be joined using a separate PVC coupling, built in sealing gaskets and restraining grooves. The restraining splines shall be square and made from Nylon 101.

Horizontal Directional Drilling  
For Restrained Pipe  
C900/RJ or C905/RJ  
Section 13001.2

- C. Exposed splines shall be cut 3/4" from coupling to reduce soil drag.
- D. Couplings shall be beveled on leading edges to minimize soil friction.
- E. Using Certa-Lok C900/RJ and C905/RJ pipe, the CONTRACTOR shall adhere to the pipe manufacturer's most current data regarding tensile load limitations for trenchless application. Generally, the maximum pull-in force shall not exceed the following values.

| Size | SDR | Class  | Pipe O.D. | Coupling O.D. | Maximum Pull-In Force Tightest Bending | Maximum Pull-In Force Straight Pull (No Bending) |
|------|-----|--------|-----------|---------------|--|--|
| 4"   | 18  | 150psi | 4.800"    | 5.964"        | 6,700 lbs.                             | 8,200 lbs.                                       |
| 6"   | 18  | 150psi | 6.900"    | 8.366"        | 9,000 lbs.                             | 12,800 lbs.                                      |
| 8"   | 18  | 150psi | 9.050"    | 10.947"       | 18,000 lbs.                            | 25,200 lbs.                                      |
| 10"  | 18  | 150psi | 11.100"   | 13.361"       | 25,600 lbs.                            | 35,200 lbs.                                      |
| 12"  | 18  | 150psi | 13.200"   | 15.836"       | 26,440 lbs.                            | 41,100 lbs.                                      |
| 16"  | 18  | 150psi | 17.40"    | 18.02"        | 65,000 lbs.                            |  |
| 4"   | 14  | 200psi | 4.800"    | 5.964"        | 8,000 lbs.                             | 10,300 lbs.                                      |
| 6"   | 14  | 200psi | 6.900"    | 8.366"        | 9,300 lbs.                             | 14,700 lbs.                                      |
| 8"   | 14  | 200psi | 9.050"    | 10.947"       | 18,900 lbs.                            | 28,800 lbs.                                      |
| 10"  | 14  | 200psi | 11.100"   | 13.361"       | 25,600 lbs.                            | 35,200 lbs.                                      |
| 12"  | 14  | 200psi | 13.200"   | 15.836"       | 26,440 lbs.                            | 41,100 lbs.                                      |

- F. CONTRACTOR shall adhere to the following data regarding radius of curvature for Certa-Lok C900/RJ and C905/RJ pipe used for trenchless application. The confirmation of proposed radius of each bore shall be part of the required submittal prior to work.

| Pipe Diameter | Min. Radius of Curvature | Offset per 20' Length | Deflection per 20' Length |
|---------------|--------------------------|-----------------------|---------------------------|
| 4"            | 125'                     | 19"                   | 10.0 Percent              |
| 6"            | 188'                     | 13"                   | 6.7 Percent               |
| 8"            | 250'                     | 9"                    | 5.0 Percent               |
| 10"           | 313'                     | 7"                    | 4.0 Percent               |
| 12"           | 375'                     | 6"                    | 3.3 Percent               |
| 16"           |                          |                       |                           |

In any case, the deflection radius shall not exceed 75% of the maximum allowable curvature allowed for standard C-900/C905 PVC pipe.

#### DIRECTIONAL DRILLING EQUIPMENT REQUIREMENTS

- A. General: The directional drilling equipment shall consist of a directional drilling rig of sufficient capacity to perform the bore and pull back the pipe, a drilling fluid mixing, delivery and recovery system of sufficient capacity to successfully complete the installation, a drilling fluid recycling system to remove solids from the drilling fluid so that the fluid can be reused (if required), a Magnetic Guidance System (MGS) or "walkover" system to accurately guide boring operations, a vacuum truck of sufficient capacity to handle the drilling fluid volume, trained and competent personnel to operate the system.

Horizontal Directional Drilling  
For Restrained Pipe  
C900/RJ or C905/RJ  
Section 13001.2

All equipment shall be in good, safe condition with sufficient supplies, materials and spare parts on hand to maintain the system in good working order for the duration of this project.

- B. Drilling Rig: The directional drilling machine shall consist of a hydraulically powered system to rotate and push hollow drilling pipe into the ground at a variable angle while delivering a pressurized fluid mixture to a guidable drill (bore) head. The machine shall be anchored to the ground to withstand the pulling, pushing and rotating pressure required to complete the installation. The hydraulic power system shall be self-contained with sufficient pressure and volume to power drilling operations. Hydraulic system shall be free of leaks. Rig shall have a system to monitor and record maximum pull-back pressure during pull-back operations. There shall be a system to detect electrical current from the drill string and an audible alarm that automatically sounds when an electrical current is detected.
- C. Drill Head: The drill head shall be steerable by changing its rotation and shall provide necessary cutting surfaces and drilling fluid jets.
- D. Mud Motors (if required): Mud motors shall be of adequate power to turn the required drilling tools.
- E. Drill Pipe: Shall be constructed of high quality 4130 seamless tubing, grade D or better, with threaded box and pins. Tools joints should be hardened to 32-36 RC.

#### GUIDANCE SYSTEM

- A. General: An electronic "walkover" tracking system or a Magnetic Guidance System (MGS) probe or proven (non-experimental) gyroscopic probe and interface shall be used to provide a continuous and accurate determination of the location of the drill head during the drilling operation. The guidance system shall be capable of tracking at all depths up to fifty feet and in any soil condition, including hard rock. It shall enable the driller to guide the drill head by providing immediate information on the tool face, azimuth (horizontal direction), and inclination (vertical direction). The guidance system shall be accurate and calibrated to manufacturer's specifications of the vertical depth of the borehole at sensing position at depths up to fifty feet and accurate to 2-feet horizontally.
- B. Components: The CONTRACTOR shall supply all components and materials to install, operate, and maintain the guidance system.
- C. The Magnetic Guidance System (MGS) shall be set up and operated by personnel trained and experienced with the system. The CONTRACTOR shall be aware of any geo-magnetic anomalies and shall consider such influences in the operation of the guidance system.

#### DRILLING FLUID (MUD) SYSTEM

- A. Mixing System: A self-contained, closed, drilling fluid mixing system shall be of sufficient size to mix and deliver drilling fluid composed of bentonite clay, potable water, and appropriate additives. The mixing system shall be able to molecularly shear individual bentonite particles from the dry powder to avoid clumping and ensure thorough mixing.

The drilling fluid reservoir tank shall be minimum of 1,000 gallons. Mixing system shall continually agitate the drilling fluid during drilling operations.

- B. Drilling Fluids: Drilling fluid shall be composed of potable water and bentonite clay. Water shall be from a authorized source with a pH of 8.5 – 10. Water of a lower pH or with excessive calcium shall be treated with the appropriate amount of sodium carbonate or equal. No additional material may be used in drilling fluid without prior approval from ENGINEER. The bentonite mixture used shall have the minimum viscosity's as measured by a March funnel:

Rocky Clay - 60 seconds  
Hard Clay - 40 seconds  
Soft Clay - 45 seconds  
Sandy Clay - 90 seconds  
Stable Sand - 80 seconds  
Loose Sand - 110 seconds  
Wet Sand - 110 seconds

These viscosities may be varied to best fit the soil conditions encountered, or as determined by the operator.

- C. Delivery System: The drilling fluid pumping system shall have a minimum capacity of 35-500 GPM and be capable of delivering the drilling fluid at a constant minimum pressure of 1200 psi. The delivery system shall have filters in-line to prevent solids from being pumped into drill pipe. Used drilling fluid and drilling fluid spilled during operations shall be contained and conveyed to the drilling fluid recycling system or shall be removed by vacuum trucks or other methods acceptable to ENGINEER and UTILITY. A berm, minimum of 12-inches high, shall be maintained around drill rigs drilling fluid mixing system, entry and exit pits and drilling fluid recycling system to prevent spills into the surrounding environment. Pumping equipment and/ or vacuum truck(s) of sufficient size shall be in place to convey drilling fluid from containment areas to storage and recycling facilities or disposal.

### **PART 3 EXECUTION**

#### GENERAL REQUIREMENTS

- A. The ENGINEER and the UTILITY must be notified a minimum of 3 days in advance of starting work.
- B. The CONTRACTOR shall be fully responsible for all damages arising from his failure to comply with all applicable regulations and the requirements of these Specifications.

#### DIRECTIONAL DRILLING OPERATION

- A. The CONTRACTOR shall provide all material, equipment, and facilities required for directional drilling. Proper alignment and elevation of the borehole shall be consistently maintained throughout the directional drilling operation. The method used to complete the directional drill shall conform to the requirements of all applicable permits. The ENGINEER will supply copies of all permits to the CONTRACTOR.

- B. The entire drill path shall be accurately surveyed by the CONTRACTOR with entry and exit stakes placed in the appropriate locations within the areas indicated on drawings. If CONTRACTOR is using a magnetic guidance system, drill path shall be surveyed for any surface geo-magnetic variations or anomalies.
- C. CONTRACTOR shall place silt fence between all drilling operations and any drainage, well-fields, wetland, waterway or other area designated for such protection if required by documents, state, federal and local regulations. Additional environmental protection necessary to contain any hydraulic or drilling fluid spills shall be put in place, including berms, liners, turbidity curtains and other measures. CONTRACTOR shall adhere to all applicable environmental regulations. Fuel may not be stored in bulk containers within 200 feet of any water body or wetland.
- D. Operation will be submitted to the ENGINEER, along with their respective Material Safety Data Sheets. All drilling fluids and loose cuttings shall be contained in pits or holding tanks for recycling or disposal, no fluids shall be allowed to enter any unapproved areas or natural waterways. Upon completion of the directional drill project, the drilling mud and cuttings shall be disposed of by the CONTRACTOR at an approved dumpsite.
- E. The pilot hole shall be drilled on bore path with no deviations greater than 5% of depth over the length of the bore unless previously agreed to by the ENGINEER/OWNER/UTILITY. In the event that pilot does deviate from the bore path more than 5% of depth over the length of the bore, CONTRACTOR will notify ENGINEER/OWNER/UTILITY may require CONTRACTOR to pull-back and re-drill from the location along bore path before the deviation. In the event of a drilling fluid fracture, inadvertent returns, or returns loss during pilot hole drilling operations, CONTRACTOR shall cease drilling, wait at least 30 minutes, inject a quantity of drilling fluid with a viscosity exceeding 120 seconds as measured by a March funnel and wait another 30 minutes. If mud fracture or returns loss continues, CONTRACTOR will discuss additional options with the ENGINEER/OWNER/UTILITY and work will then proceed as agreed.
- F. Upon completion of pilot hole phase of the operation, a complete set of "as-built" records shall be submitted in duplicate to the ENGINEER, UTILITY and OWNER. These records shall include copies of the pilot bore path plan and profile record drawing, as well as directional survey reports as recorded during the drilling operation.
- G. Upon approval of the pilot hole location by the ENGINEER/OWNER/UTILITY, the hole opening or enlarging phase of the installation shall begin. The bore hole diameter shall be increased to accommodate the pullback operation of the required size of carrier pipe. The type of hole opener or back reamer to be utilized in this phase shall be determined by the types of subsurface soil conditions that have been encountered during the pilot hole drilling operation. The CONTRACTOR shall select the proper reamer type with the final hole opening being a maximum of 1.5 times the largest outside diameter pipe system component to be installed in the bore hole.
- H. The open bore hole shall be stabilized by means of bentonite drilling slurry pumped through the inside diameter of the drill rod and through openings in the reamer. The drilling slurry must be in a homogenous / flowable state serving as an agent to carry the loose cuttings to the surface through the annulus of the borehole. The volume of



bentonite mud required for each pullback shall be calculated based on soil conditions, largest diameter of the pipe system component, capacity of the bentonite mud pump, and the speed of pullback as recommended by the bentonite drilling fluid manufacturer. The bentonite slurry is to be contained at the exit or entry side of the directional bore in pits or holding tanks. The slurry may be recycled at this time for reuse in the hole opening operation, or shall be hauled by the CONTRACTOR to an approved dumpsite for proper disposal.

- I. The pipe section shall be joined together according to manufacturer's specifications. The gaskets and the ends of pipe must be inspected and cleaned with a wet cloth prior to each joint assembly so they are free of any dirt or sand. The pipe must be free of any chips, scratches, or scrapes. A pulling eye will be attached to the Certa-Lok C900/RJ pulling head on the lead stick of pipe which in turn will be attached to a swivel on the end of the drill pipe. Tracer wire (#8) solid coated copper wire shall be attached to the pulling eye and the crown of PVC pipe with duct tape @ 24" O.C. and a minimum of two full wraps around the pipe. This will allow for a straight, smooth pull of the product pipe as it enters and passes through the borehole toward the drill rig and original entrance hole of the directional bore. The product pipe shall be elevated to the approximate angle of entry and supported by means of a sideboom with roller arm, or similar equipment, to allow for the "free stress" situation as the pipe is pulled into the exit hole toward the drill rig. The product pullback phase of the directional operation shall be carried out in a continuous manner until the pipe reaches the original entry side of the bore.

#### PIPE HANDLING

- A. Care shall be taken during transportation of the pipe such that it will not be cut, kinked or otherwise damaged.
- B. Ropes, fabrics or rubber protected slings and straps shall be used when handling pipes. Chains, cables or hooks inserted into the pipe ends shall not be used. Two slings spread apart shall be used for lifting each length of pipe. Pipe or fittings shall not be dropped into rocky or unprepared ground.
- C. Pipes shall be stored on level ground, preferably turf or sand, free of sharp objects that could damage the pipe. Stacking of the Certa-Lok C900 / RJ pipe shall be limited to a height that will not cause excessive deformation of the bottom layers of pipes under anticipated temperature conditions. Where necessary due to ground conditions the pipe shall be stored on wooden sleepers, spaced suitably and of such width as not to allow deformation of the pipe at the point of contact with the sleeper or between supports.
- D. The handling of the assembled pipeline shall be in such a manner that the pipe is not damaged by dragging it over sharp and cutting objects. Slings for handling the pipeline shall not be positioned at pipe joints. Sections of the pipes with cuts and gouges or excessive deformation shall be removed and replaced.

#### TESTING PIPE

- A. Unless testing is done as part of longer sections of pipework, cleaning and flushing are to be done by the CONTRACTOR in order to obtain a clear and debris free product. Only potable water shall be used for flushing and pressure testing.

- B. Directional drilling pipe shall be tested by CONTRACTOR after pullback. The average pressure shall be maintained at 150 psi for two hours. The test pump and water supply shall be arranged to allow accurate measurements of the water required to maintain the test pressure. Any material showing seepage or the slightest leakage shall be replaced as directed by the OWNER at no additional expense to the OWNER.
- C. The pipe manufacturer's (or ENGINEER'S/OWNER'S/UTILITY'S, whichever is more stringent) recommendations on pipe stretch allowances, bending radius, tensile strength, allowable test leakage allowance, and magnitude and duration of test pressure shall be observed.
- D. Pipeline shall be tested end to end.
- E. All new service lines connected to the new main and installed with new pipe shall be pressure tested along with the newly installed main.
- F. Pressure testing shall not be required for the drilled pipe if the pipe is intended to be used as a casing for a finished product pipe.

**END OF SECTION**

**SECTION 13001.5  
 DRY, WET, AND DIRECTIONAL BORING  
 AND WORK ON STATE HIGHWAY**

**PART 1.00 NOTICE**

The General Conditions, Special Conditions and all other herein bound and accompanying documents are part of these Specifications and of the Contract. Submission of proposal implies that the Bidder is fully conversant with all requirements of all above-mentioned documents.

**PART 2.00 APPLICABLE PUBLICATIONS**

Standards of the American Society for Testing and Materials (ASTM), latest edition; Standard Specifications of American Standards Association (ASA), latest edition, State Highway Department Standard Specifications for Road and Bridge Construction, latest edition; Policies and Procedures for Accommodating Utilities within Highway Rights-of-way.

**PART 3.00 SCOPE OF THE WORK**

- 3.01 The work under this section consists of furnishing all materials, accessories, equipment, tools, transportation, service, labor and performing all operations necessary to completely execute highway crossings work for this project, all as indicated on the drawings and as herein specified.
- 3.02 All requirements of the State Highway Department shall be met by the Contractor. Lights and barricades of the required number shall be placed to reduce traffic hazards and these shall be maintained until the work is completed.

**PART 4.00 PIPE SIZE (NOT APPLICABLE)**

Carrier pipe and casing pipe sizes shall be as follows:

| <b><u>CASING PIPE:</u></b>     |   |  | <b><u>CARRIER PIPE NOMINAL SIZE :</u></b> |                                |
|--------------------------------|---|--|---|--------------------------------|
| <b><u>NOMINAL<br/>SIZE</u></b> | <b><u>MINIMUM<br/>INTERNAL<br/>DIAMETER</u></b> | <b><u>MINIMUM<br/>WALL<br/>THICKNESS</u></b> | <b><u>TYPE K<br/>COPPER</u></b>           | <b><u>PVC<br/>(CL 200)</u></b> |
| 12"                            | 11.656  | 0.172  | 3/4"                                      | 6"                             |
| 14"                            | 13.562  | 0.219  |   | 8"                             |
| 16"                            | 15.562  | 0.219  |   | 10"                            |
| 18"                            | 17.500  | 0.250  |   | 12"                            |
| 20"                            | 19.438  | 0.281  |   |                                |
| 22"                            | 21.376  | 0.312  |   |                                |
| 24"                            | 23.250  | 0.375  |   |                                |
| 26"                            | 25.124  | 0.438  |   |                                |
| 28"                            | 27.124  | 0.438  |   |                                |
| 30"                            | 29.124  | 0.438  |   |                                |

## **PART 5.00 CASING PIPE (NOT APPLICABLE)**

- 5.01 Casing pipe, except two-inches (2"), shall be steel having a minimum yield strength of 35,000 psi. Two-inch (2") SDR-21, 200 psi PVC casing pipe may be used with ¾-inch carrier pipe.
- 5.02 Casing pipe joints shall be made by continuous weld completely around the perimeter of the pipe, shall be watertight and shall provide a strength through the joint equal to that of the casing pipe shell.
- 5.03 Casing pipe shall be so constructed as to prevent leakage of any substance from the casing throughout its length except at ends.
- 5.04 Under certain conditions casing pipe may be omitted. In these cases, ductile iron pipe may be used only if minimum cover is 36-inches.

## **PART 6.00 CARRIER PIPE**

Carrier pipe shall be specified under the applicable utility section.

## **PART 7.00 DRY BORING AND JACKING OPERATIONS**

- 7.01 All boring and jacking operations of steel casing pipes, also installation of sewer and water pipes in casing pipes are included in this Contract, all as shown on drawings, approved shop drawings and as herein specified. Such installation will generally be for crossing under private rights-of-way, highways, arterial streets or other special cases. Both casing pipe and carrier pipe shall be provided in lengths short enough for proper placement and handling in the jacking pit.
- 7.02 The work specified herein covers two (2) basic methods of installing casing pipe mechanically (and in which diameter of casing pipe is too small to permit hand working at heading of casing pipe).
  - A. Pushing casing pipe into fill or earth simultaneously with boring auger, as it drills the earth.
  - B. Drilling hole through the earth or fill and pushing casing and carrying pipe into the hole after drill auger has completed bore.
- 7.03 Open a suitable trench adjacent to slope of embankment or adjacent to bored or jacked section, as shown on drawings. Length of approach trench: sufficient to accommodate selected lengths of pipe sections to be jacked and wide enough to provide sufficient working space. Set and maintain guide timbers or rails accurately in bottom of approach trench, in order to keep casing pipe on correct line and grade.

- 7.04 Provide and install heavy, timber backstop supports at rear of approach trench, adequate to take thrust of jacks without movement or distortion. It is requisite to securing of tolerance limits of boring and jacking operation to set all rails, guides and jacks exactly, so that casing pipe in final position is within limits of acceptability, as noted on drawings and approved by the Engineer.
- A. Casing shall be so installed as to prevent the formation of a waterway, with an even bearing throughout its length, and shall slope to one (1) end (except for longitudinal occupancy).
  - B. Bored or jacked installations shall have a bored hole diameter essentially the same as the outside diameter of the pipe plus the thickness of the protective coating. If voids should develop or if the bored hole diameter is greater than the outside diameter of the pipe (including coating) by more than approximately one-inch (1"), remedial measures as approved by the Chief Engineer of the Highway Department or the Engineer shall be taken. Boring operations shall not be stopped if such stoppage would be detrimental to the roadway.
  - C. Tunneling operations shall be conducted as approved by the stated authority. If voids are caused by the tunneling operations, they shall be filled by pressure grouting or by other approved methods which will provide proper support.
  - D. Carrier pipes for boring and jacking operations: assemble joints to casing pipe and push the assembly through casing pipe so that carrier pipe will be on a uniform grade, as indicated on drawings. Provide approved, adequate blocking as conditions require or as directed where necessary to maintain grades shown on drawings.
  - E. Where the ends of the casing are below ground, they shall be suitably protected against the entrance of foreign material, but shall not be tightly sealed if the fluid conducted flows by pressure. If the fluid flow is by gravity and the ends of casing are below ground, they shall be protected against the entrance of foreign material after the carrier pipe has been installed by filling each end with concrete grout. Before the grout is placed, a plug of paper or cloth shall be stuffed in the casing pipe to limit the plug to six-inches (6") thickness. Where the ends of the casing are at or above ground surface and above high water level they may be left open, provided drainage is afforded in such manner that leakage will be conducted away from highways.

## **PART 8.00 WET BORING AND JACKING OPERATIONS**

- 8.01 With the approval of the State Highway Department, wet bore alternates using either a gel-forming colloidal drilling fluid or a poly-surfactant mixture in accordance with the following specifications may be permitted.

A. ALTERNATE NO. 1 - GEL-FORMING COLLOIDAL MIXTURE

The casing is to be installed by drilling a hole of a size not larger than one-fourth-inch (1/4") around the outside circumference of the casing or pipe with an open type bit that leaves the cuttings in place. A gel-forming colloidal drilling fluid consisting of at least 10% of high grade carefully processed Bentonite will be used to consolidate cuttings of the cutting bit, seal the walls of the hole, and furnish lubrication for subsequent removal of cuttings and installation of the casing immediately thereafter. When drilling through dense formations, cuttings may be partially removed from the hole in three-foot (3') plugs by use of compressed air as drilling progresses. However, in low-density soil of a sandy or silty nature, a plug shall be installed in the mouth of the bore to prevent the movement of any cuttings from the hole until immediately before installation of the casing. No bit larger than three-inches (3") in diameter shall have holes therein larger than five-sixteenths-inch (5/16") in diameter through which drilling fluid is forced during boring.

B. ALTERNATE NO. 2 - POLYMER-SURFACTANT MIXTURE

The casing is to be installed by drilling a hole of a size not larger than one-fourth-inch (1/4") around the outside circumference of the casing or pipe with an open type bit that leaves the cuttings in place. A polymer-surfactant of approximately 61% diesel fuel, 15% sodium carboxy methyl cellulose, 2.5% anionic surfactant and 21.5% water will be used to consolidate cuttings of the cutting bit, seal the walls of the hole, and furnish lubrication for subsequent removal of the cuttings and installation of the casing immediately thereafter. When drilling through dense formation, cuttings may be partially removed from the hole in three-foot (3') plugs by use of compressed air as drilling progresses. However, in low-density soil of a sandy or silty nature, a plug shall be installed in the mouth of the bore to prevent the movement of any cuttings from the hole until immediately before installation of the casing. No bit larger than three-inches (3") in diameter shall have holes therein larger than five-sixteenths-inch (5/16") in diameter through which the drilling fluid is forced during boring. The polymer-surfactant mixture, when used in clay soils, will consist of five (5) gallons of polymer-surfactant to 500 gallons of water and when used in clay soils containing considerable sand will consist of ten (10) gallons of polymer-surfactant to 500 gallons of water.

**PART 9.00 REMOTE CONTROL TUNNELING OPERATION -  
FOR WATER MAINS ONLY (10-INCH CASING AND SMALLER)**

9.01 An alternative method of utility placement shall be in a trenchless manner, producing continuous bores. The tunneling system shall be remotely steerable and permit electronic monitoring of tunnel locations and depth. Tunneling must be performed by a fluid cutting process (high pressure/low volume) utilizing a liquid clay, such as bentonite. The clay lining shall maintain tunnel stability and provide lubrication in order to reduce

friction drag on the utility being installed. In addition, the clay fluid shall be totally inert and contain no environmental risk and shall be compatible with all insulation types. The tunneling system shall be steerable and shall be capable of turning in a thirty-foot (30') radius to avoid obstacles such as existing utilities, rocks, trees and shall be able to stay within the right-of-way. The fluid jets on the cutting tool shall vary in size in order to tailor the tunnel for a particular utility diameter and/or soil conditions.

- 9.02 The remote cutting tool locating device must be capable of detecting the position of the fluid cutting head within the accuracy and depth of the parameters outlined below:

| Depth      | +/- Elevation | +/- Left/Right |
|------------|---------------|----------------|
| 0- 5 Feet  | 1"            | 1"             |
| 5-10 Feet  | 2"            | 3"             |
| 10-15 Feet | 3"            | 5"             |
| 15-25 Feet | 4"            | 8"             |

- 9.03 If the utility is greater than two-inches (2") in diameter, a reamer shall be installed at the termination pit and the utility shall be pulled back to the launch pit. The reamer shall be capable of discharging liquid clay to facilitate the installation of the utility into a stabilized and lubricated tunnel.
- 9.04 All project remediation shall be performed by the Contractor. The Contractor shall be responsible for removing all excess mud from the pits and provide for proper disposal. All pits shall be backfilled and restored to their original condition (reseeding, replacing sod and shrubbery.)

**PART 10.00 CONTROLS GOVERNING UTILITY INSTALLATIONS AS PUBLISHED IN “POLICIES AND PROCEDURES FOR ACCOMMODATING UTILITIES WITHIN HIGHWAY RIGHTS-OF-WAY” BY THE TENNESSEE DEPARTMENT OF TRANSPORTATION**

- 10.01 The following controls shall govern the installation of utility facilities within or over highway rights-of-way:

- A. At all times construction and maintenance of utility facilities is in progress, the Contractor shall provide signing and if required flagging for control of traffic. Signing shall conform to Part VI of the Manual on Uniform Traffic Control Devices for Streets and Highways. The Contractor shall substitute the word “Utility” on signs where the word “Road” appears.
- B. Areas disturbed by utility installations, relocations or removals shall be kept to a minimum. Utilities will not be permitted to install facilities by cutting the pavement or adjacent shoulders of State highways except in extreme hardship cases where soil conditions prohibit other feasible and economical methods of installing facilities under the highway. In no instance will the Tennessee

Department of Transportation permit cutting of the traveled way of freeway highways to facilitate installation of utility facilities after the highway is complete and placed in service. The Tennessee Department of Transportation's Regional Engineering Director must approve open cutting of the highway and conditions under which the work is to be performed shall be incorporated as a special provision in the Use and Occupancy Agreement.

- C. If the Department approves installation of Utility facilities by open cutting the highway as set out in Paragraph B above, the Contractor will be required to accommodate the traveling public at all times by keeping one (1) lane of traveled way open and providing necessary flagging and/or construction signing to properly inform the traveling public of the impairment to normal traffic flow.
- D. The Contractor shall replace or repair any portion of the right-of-way, embankment, pavement, shoulders, highway bridges and drainage structures, guardrail, private driveways, access roads or ramps or any other part of said highway which may be disturbed or damaged. Repair work will be in accordance with applicable provisions of the "Standard Specifications for Road and Bridge Construction" and special provisions or instructions issued by the Tennessee Department of Transportation and/or made a part of the Use and Occupancy Agreement. In the event replacement or repairs made by the Contractor are not satisfactory to the Tennessee Department of Transportation, the Tennessee Department of Transportation, at their discretion, will undertake the work and the utility company shall reimburse the Tennessee Department of Transportation for the cost of such work. Except in cases of emergency, the Tennessee Department of Transportation shall notify the Contractor of the nature and extent of such replacements or repairs to be accomplished prior to undertaking the work.
- E. No excavated material or equipment shall be placed on the pavement or shoulders of the highway without the express approval of the Tennessee Department of Transportation's Regional Engineering Director where such procedures warrant. In no instance will the Contractor be permitted to leave equipment (trucks, cranes, backhoes, etc.) on the pavement or shoulder overnight. Materials (poles, cable, pipe) to be installed, which are placed on the right-of-way in advance of construction, shall be placed in such a manner as not to interfere with the safe operation of the highway.
- F. The trimming, cutting, spraying or removal of trees and shrubs or other vegetation located within the highway right-of-way shall either be permitted or denied in accordance with then current regulations established by the Maintenance Division of the Tennessee Department of Transportation. In cases where rest areas or land acquired for scenic enhancement of the highway is involved, approval of the State Transportation Engineer is required.
- G. Boring, jacking or driving of encasement or carrier pipes under existing highways shall be accomplished without jetting, sluicing or wetboring unless express



approval of the method to be utilized is obtained from the Tennessee Department of Transportation's Regional Engineering Director in writing.

- H. All debris, refuse and waste of all kinds which have accumulated upon the Highway right-of-way as a result of the installation of utility facilities shall be removed immediately upon completion of construction operations.
- I. The Contractor shall schedule the installation of facilities in an orderly manner and shall not leave ditches, boring pits and other hazards to the traveling public open for extended periods of time. At such time as construction is commenced, it shall proceed without delay to completion subject to weather and conditions beyond the control of the Contractor.
- J. Condition of the highway rights-of-way during and after construction is subject to approval of duly authorized representatives of the Department of Transportation. The Contractor will be responsible for maintenance of disturbed areas of highway rights-of-way for a period of one-year after acceptance of the condition of the rights-of-way subsequent to completion of all construction activities.
- K. The oversize of the boring excavation shall be no greater than one-inch (1") in excess of the outside diameter of the encasement or carrier pipe being installed. Grout backfill shall be used for pipes in excess of twelve-inches (12") in diameter and for overbreaks, unused holes, or abandoned pipes.
- L. Where utility installations will encroach longitudinally within and across highway rights-of-way for 1500-feet or more, the Contractor shall place construction identification signs at both termini of the work at locations designated by the Bureau's Regional Utility Engineer. These signs shall, as a minimum, be of size and type as shown by the appropriate drawing included with the Use and Occupancy Agreement.

END OF SECTION

**DIVISION 13 SPECIALTY CONTRUCTION**  
**SECTION 13015**  
**GENERAL REQUIREMENTS - TELEMETRY**

**PART 1 GENERAL**

1.1 Work Included:

- A. Telemetry work shall include all construction in connection with controls, instrumentation, networking, software, computer hardware and telemetry as described in the following sections of the specifications.
  - 1. 13955 Telemetry
- B. Work specified under this section includes furnishing of and paying for all materials, labor, equipment licenses, taxes, and other items required for execution and completion of all work indicated.
- C. Everything necessary for a complete and satisfactory installation including all necessary parts, devices, accessories, etc., required by codes or that may be required to satisfactorily complete the installation of the above items shall be provided.

1.2 Related Work:

Programming of Telemetry System originally performed by Gaines, Williams & Associates.

1.3 Verification Of Utilities and Services:

Immediately upon commencing construction, and prior to construction of any part of the facility involved in any way with utilities, investigate thoroughly the size, capacity, arrangement and location of utilities. Report any discrepancies or apparent problem involving the project that pertains to utilities. This applies to private as well as public utilities.

1.4 Requirements Of Regulatory Agencies:

- A. All work shall be executed and inspected in accordance with all local or state codes, laws, ordinances, rules and regulations applicable to the particular class of work and shall include all applicable service charges, fees, permits, royalties, taxes, and other similar costs in connection therewith. If the drawings or specifications are at variance with above mentioned laws, rules and regulations, notify the Designer in writing so any necessary changes can be provided prior to Contract.

- B. If the Contractor performs any work knowing it to be contrary to such laws, rules or regulations, and without notice as required above, he shall bear costs arising there from. The drawings and specifications take precedence when they are more stringent than codes, ordinances, or statutes in effect.
- C. Applicable codes, ordinance, standards and statutes take precedence where they are more stringent or conflict with the drawings and specifications.

1.5 Drawings:

- A. It is intended that all apparatus be located symmetrically with architectural elements, and shall be installed at exact height and locations as shown on the architectural drawings.
- B. Be acquainted with any and all peculiarities and limitations of the spaces available for the installation of all work and materials furnished and installed under this section of the specifications. Exercise due and particular caution to determine that all parts of the work are made quickly and easily accessible.
- C. Although the locations of the equipment and piping may be shown on the drawings in certain positions, should the Contractor discover conflicts or interferences during progress of the work he shall report any discrepancies or interferences that are discovered. Failure to report such discrepancies and interferences shall result in the correcting of these errors or omissions by this section at the Contractor's own expense. All work installed under this section which deviates from the drawings and specification without prior approval, shall be altered by this section at the Contractor's own expense, to comply with the drawings and specifications as directed.

1.6 Equipment Submittals:

- A. Three copies of shop drawings and/or manufacturer's descriptive data of a nature to completely identify the equality of the material or equipment intended for installation shall be submitted for approval before beginning any construction and within thirty days after signing contract. Failure to submit data for approval within thirty days time limit will be construed as meaning equipment called for by name will be furnished. Data shall be organized in same order as listed below, shall be submitted all in one brochure, indexed by flysheet on front page, and be bound in sets, all sets identical. No exception will be made to this procedure and time schedule.
- B. Each item submitted for review shall have submittal data preceded by a typewritten description (by Contractor or item supplier) of the item. Description to include make and model numbers and shall describe the item. List all options and accessories which are included. List any options or accessories shown on shop drawings which are not included.

- C. Submit the following for approval, referring to the various sections of Division 13 for specific items:
  - 1. Instrumentation
  - 2. Circuit Breakers
  - 3. PLC Equipment
  - 4. Antenna Structures
  - 5. Lightning Arrestors
  - 6. Radio Modems and Related Equipment

1.7 Guarantee:

- A. All work performed under this division shall be guaranteed to be free from defects in material and workmanship from date of substantial completion of such work for a period of twelve (12) months.
- B. Latent defects arising during this period shall, upon notification by the Owner, be promptly corrected at no additional cost to the Owner.

**PART 2 PRODUCTS**

2.1 Materials and Equipment:

- A. Materials and/or equipment involved in the specified installation shall be of the best for the purpose intended and shall meet with the requirements of the contract documents. The Owner reserves the right to reject any materials and workmanship not in accordance with those specified or not meeting with the Designer's approval, either before or after installation.
- B. Where materials and equipment are indicated by manufacturer's name, type, model, or catalog number, such items or one of those so specified must be included in the base bid for Contract. Other materials and equipment will not be acceptable unless noted otherwise.

2.2 Control Wiring

- A. Division 16 shall furnish and install all electrical power, control and interlock wiring required for the proper operation of all mechanical equipment specified in Division 13.
- B. All control wiring shall be in accordance with the National Electrical Code and Division 16.

2.3 Operating and Maintenance Instructions:

- A. Furnish and turn over to the Owner three (3) copies of operation and maintenance instructions, to include:

1. Complete set of approved submittal data on installed equipment.
  2. Operating instructions on all equipment.
  3. Parts lists on all equipment, along with name, address, and telephone number of source of purchase or local representative.
  4. Copies of all warranties or guarantees.
  5. Copies of installation instructions when furnished with equipment.
  6. Copies of all software licenses.
  7. Recommended list of spare parts.
- B. Instructions shall be in hard cover binder with index. Insert in order as listed in the specifications under Products for each section.

### **PART 3 EXECUTION**

#### 3.1 Coordination:

- A. Coordinate all work on the job and also with that of the Owner, in order that there will be no delay in the proper installation and completion of the work. Any cost for extra work or materials resulting from lack of coordination of work performed under this division shall be at the Contractor's expense.
- B. Coordinate with the Owner when construction work requires the shutdown of utilities (including interruption of City water for connection or alteration and perform such a work at a time agreeable to the Owner).
- C. Prior to any excavation Contractor shall call Tennessee One-Call for location of utilities.

#### 3.2 Workmanship, Materials and Equipment:

All work shall be performed in a workmanlike manner and shall present a neat and acceptable appearance when completed. All materials shall be of type, quality, and of minimum rating prescribed herein or as indicated on the plans.

#### 3.3 Manufacturer's Recommendations:

- A. All material and equipment shall be installed in strict accordance with the manufacturer of such material and equipment.
- B. In the event of discrepancy between manufacturer's recommendations and any requirements of drawings or specifications, Contractor shall notify Designer in order that the matter can be cleared up prior to any installation of materials or equipment.

3.4 Protection Of Work:

Protect work at all times from danger by freezing, breakage, dirt, foreign materials, etc., and replace all work so damaged. Use every precaution to protect the work of others, and be responsible for all damage to other work caused by work of, or through the neglect of workmen under this division of the specifications.

3.5 Equipment/Antenna Supports:

Furnish and erect all necessary steel members, frames, connections, etc., to support equipment and antennas installed under each section of this division, regardless of whether the drawings indicate support details or not. Submit details of supports to Architect/Engineer for approval prior to fabrication.

3.6 Testing:

Upon completion of work, all equipment shall be cleaned and adjusted for proper operation and any defects discovered shall be corrected before final inspection prior to acceptance.

3.7 Clean-Up:

Keep the premises free from accumulation of waste materials or rubbish caused by employees or work under this section of the specifications. At the completion of the work, remove all surplus materials, tools, etc., and leave the premises "Broom-Clean".

END OF SECTION

## DIVISION 13 SPECIALTY CONSTRUCTION

### SECTION 13955 TELEMETRY

#### **PART 1 GENERAL**

##### 1.1 Requirements:

- A. The General and Supplementary Conditions and Division 1 govern this Section.
- B. Refer to Section 13015 “General Requirements - Telemetry” for requirements applying to all sections of Division 13 including, but not limited to, the following:
  - 1. Verification of Utilities
  - 2. Requirements of Regulatory Agencies
  - 3. Drawings
  - 4. Equipment Schedule
  - 5. Guarantee
- C. Radio System: Within twenty-one (21) calendar days after the Contractor has received the Owner’s Notice to Proceed, submit:
  - 1. Radio Path Analysis, frequency 158.3175Mhz
  - 2. Co-channel interference analysis report
  - 3. Inter-mod analysis report
  - 4. Telemetry recommendation
  - 5. Copies of FCC license applications, if applicable

The Contractor shall be responsible for furnishing and installing radio equipment in compliance with findings of system analysis including, but not limited to, antenna elevation at lift station site, radio repeaters, etc. The Contractor shall furnish and install a complete and functioning radio system which shall interface with the City’s existing radio system.

##### 1.2 Work Included:

- A. All equipment and materials shall be new, unused and proved by previous use of similar products to be completely suitable for the service intended. All materials/equipment shall be new and in the manufacturers original packing with seals unbroken. Used or remanufactured or used materials/equipment shall not be accepted. The Owner and Owner’s Representative shall inspect all boxes prior to manufacturer’s seals being broken and panel fabrication beginning. All materials shall be purchased from manufacturer authorized distributors for the City of Munford.

- B. Furnish and install all Radios, Antennas, and Communication Equipment as specified herein and shown on the contract drawings.
- C. Furnish and install programmable logic controllers (PLC) control panels and miscellaneous panel equipment as specified herein and shown on the contract drawings.
- D. Furnish and install antenna structures and foundations, and all appurtenances necessary for a complete installation of antennas and cable.
- E. Furnish and install all control, communication and power wiring.
- F. The Contractor shall provide onsite personnel during start-up for adjustment of antennas and wiring check-out.

1.3 Related Work:

Programming of the telemetry system originally performed by Gaines, Williams & Associates, Inc.

1.4 Reference Standards:

All work must be performed in accordance with the requirements of the following pertinent standards and legal codes and ordinances:

1. Standard Building Code and Publications referred to therein.
2. Life Safety Code, NFPA No. 101.
3. Occupational Safety and Health Act (OSHA).
4. National Electrical Code (NEC).
5. American National Standards Institute (ANSI).
6. American Society of Mechanical Engineers (ASME).
7. Standards and Periodicals Listings, Underwriters Laboratories.
8. For work not specifically listed above, use the standards and codes of the National Fire Protection Association (NFPA).

1.5 Contractor Qualifications:

- A. The radio modem, antenna and cable shall be installed by a firm actively engaged in the communications industry.
- B. The firm shall have successfully built and placed into operation systems similar to the proposed system herein and furnish a list of operating installations as references upon request by the engineer.



## **PART 2 PRODUCTS**

### 2.1 General Requirements:

Refer to Section 13015, "General Requirements – Telemetry", for requirements applying to all sections of Division 13 including, but not limited to, the following:

1. Material and Equipment.
2. Operating and Maintenance Instructions.

### 2.2 Electrical Control Wiring:

- A. All wiring shall comply with National Electrical Code and Division 16 "Electrical".
- B. All wiring indoor, outdoor and underground shall be in rigid steel conduit, (including antenna and communication cable). IMC conduit shall not be accepted.

### 2.3 General Telemetry and RTU Panel Requirements

- A. All Telemetry and RTU panels shall be shop fabricated per the contract documents and UL508A listed. Equipment shall be furnished exactly as shown on the documents and in Bills of Materials, no exceptions.
- B. Discrete copper internal control panel wiring shall be UL rated Type E-16 single conductor stranded silver plated copper with extruded TFE Teflon insulation. Wire shall be suitable for operation at 600 volts as specified in the National Electric Code, at conductor temperatures not to exceed 200EC. Wire shall be resistant to acid, alkalis, oil, flame, moisture, solvents and fungus. Wire color code shall be as follows:

|                  |   |   |
|------------------|---|---|
| Black            | - | 120 VAC power   |
| White            | - | 120 VAC neutral   |
| Green            | - | Ground  |
| Red              | - | 120 VAC input wiring  |
| Purple           | - | 120 VAC output wiring   |
| Blue             | - | 24 VDC positive   |
| Blue/White Strip | - | 24 VDC positive   |
| Yellow           | - | Circuit conductors which remain energized when supply disconnecting means is off. |

- C. Single pair analog cable shall be tinned copper, polyethylene insulated, twisted pair with 100% akynunyn-polyester shield coverage, 20 AWG stranded tinned copper drain wire and chrome PVC jacket. Cable shall be Beldon 8760.

## **PART 3 EXECUTION**

### 3.1 General Requirements:

Refer to Section 13015, "General Requirements – Telemetry" for requirements applying to all sections of Division 13 including, but not limited to, the following:

1. Coordination
2. Workmanship, Materials And Equipment
3. Manufacturer's Recommendations
4. Protection Of Work
5. Equipment/Antenna Supports
6. Testing
7. Clean-Up

### 3.2 Field Device/Enclosure Identification

- A. All RTU Control Panels shall be mounted as shown on the contract documents.
- B. All I/O field devices that are not mounted within an enclosure shall be identified with name plates.
- C. All I/O field devices inside LC/FIP's shall be labeled.
- D. The identification shall match all documentation and identify the function (i.e. mixed air temperature sensor).
- E. Calibration settings shall be marked with paint or indelible ink.
- F. Each terminal strip termination shall be tagged with an identification that matches the control drawings.
- G. The outside of each enclosure shall be identified with a engraved plastic label matching the identification name shown on the control drawings prepared by the Contractor. The lettering shall be in white against a black or blue background.

### 3.3 Marking:

- A. Each telemetry component shall be plainly and permanently marked with the number or symbol as it appears on the control diagram.
- B. Where one control diagram serves more than one system additionally identify with system number.
- C. Junction box covers will be marked to indicate that they are a part of the telemetry system.

3.4 Identification:

Wire, cable, terminal and fuse labels shall consist of the complete wire number matching exactly the wire number shown on the wiring diagrams, custom printed on a single pressure sensitive, self-adhesive tape which wraps the entire circumference of the wire or cable. Handwriting or combining multiple labels to mark the wire number shall not be permitted.

3.5 Operating and Maintenance Instructions:

Furnish operating and maintenance instructions per Section 13015, “General Requirements – Telemetry”.

3.1 Check, Test and Start-up

- A. Direct and adjust antennas as necessary during start-up to provide maximum signal strength.

END OF SECTION

**SECTION 15050.12**  
**FACTORY-BUILT 6X6 ABOVE GROUND PUMP STATION**  
**WITH DUPLEX SELF-PRIMING PUMPS**

**PART - GENERAL**

1.01 Work under this section includes, but is not limited to furnishing and installing a factory built duplex pump station as indicated on the project drawings, herein specified, as necessary for proper and complete performance.

1.02 Publications listed below form part of this specification to extent referenced in the text by basic designation only. Consult latest edition of publication unless otherwise noted.

- A. American National Std. Institute (ANSI) / American Water Works Assoc. (AWWA)
  - 1. ANSI B16.1 Cast iron pipe flanges and flanged fittings.
  - 2. ANSI/AWWA C115/A21.51 Cast/ductile iron pipe with threaded flanges.
  - 3. ANSI 253.1 Safety Color Code for Marking Physical Hazards.
  - 4. ANSI B40.1 Gages, Pressure and Vacuum.
  - 5. AWWA C508 Single Swing Check Valves.
  
- B. American Society for Testing and Materials (ASTM)
  - 1. ASTM A48 Gray Iron Castings.
  - 2. ASTM A126 Valves, Flanges, and Pipe Fittings.
  - 3. ASTM A307 Carbon Steel Bolts and Studs.
  - 4. ASTM A36 Structural Steel.
  
- C. Institute of Electrical and Electronics Engineers (IEEE)
  - 1. IEEE Std 100 Standard Dictionary of Electrical Terms.
  - 2. IEEE Std 112 Test Procedure for Polyphase Induction Motors.
  - 3. IEEE Std 242 Protection of Industrial and Control Power Systems.
  
- D. National Electric Code (NEC) / National Electrical Manufacturers' Assoc. (NEMA)
  - 1. NEC National Electrical Code.
  - 2. NEMA Std MG1 Motors and Generators.
  
- E. Miscellaneous References
  - 1. Ten-State Standards Recommended Standards for Sewage Works.
  - 2. Hydraulic Institute Std for Centrifugal, Rotary and Reciprocating Pumps.
  - 3. ISO 9001 International Organization for Standardization.

1.03 SYSTEM DESCRIPTION

A. Design requirements consist of factory built pump station design, including materials of construction, pump features, valves and piping, and motor controls shall be in accordance with requirements listed under PART 2 - PRODUCTS of this section.

- 1. Contractor shall furnish and install one factory built above ground, automatic pump station. The station shall be complete with all equipment specified herein, factory assembled in a fiberglass reinforced polyester resin enclosure.

2. In addition to the station enclosure, principle items of equipment shall include two horizontal, self priming, centrifugal sewage pumps, V-belt drives, motors, internal piping, valves, motor control panel, automatic liquid level control system, and internal wiring.

*NOTE: The following Parts B and C must be completed by the Design Engineer*

**B. Performance Criteria**

1. Pumps must be designed to handle raw, unscreened, domestic sanitary sewage. Pumps shall have \_\_\_" suction connection, and \_\_\_" discharge connection. Each pump shall be selected to perform under following operating conditions:

- |                                    |       |
|------------------------------------|-------|
| a. Capacity (GPM)                  | _____ |
| b. Total Dynamic Head(FT)          | _____ |
| c. Total Dynamic Suction Lift(FT)  | _____ |
| d. Maximum Repriming Lift(FT)      | _____ |
| e. Maximum Static Suction Lift(FT) | _____ |
| f. Total Discharge Static Head(FT) | _____ |
| g. Minimum Submergence Depth (FT)  | _____ |

**C. Utility Power Requirements**

1. Site power furnished to pump station shall be \_\_\_ phase, \_\_\_ hertz, \_\_\_ volts, \_\_\_ wire, maintained within industry standards. The available fault current provided at the pump station control panel is \_\_\_\_\_ kA rms symmetrical. Voltage tolerance shall be plus or minus 10 percent. Phase-to-phase unbalance shall not exceed 1% average voltage as set forth in NEMA Standard MG-1. Control voltage shall not exceed 132 volts.

**1.04 SUBMITTALS**

**A. Product Data**

1. Prior to fabrication, pump station manufacturer shall submit five (5) copies of submittal data for review and approval.
2. Submittal shall include shop drawings, electrical ladder logic drawings, and support data as follows: Catalog cuts sheets reflecting characteristics for major items of equipment, materials of construction, major dimensions, motor and v-belt drive data, pump characteristic curves showing the design duty point capacity (GPM), head (FT), net positive suction head required (NPSHr), and hydraulic brake horsepower (BHP). Electrical components used in the motor branch and liquid level control shall be fully described.

**B. Shop Drawings**

1. Shop drawings shall provide layout of mechanical equipment and anchor bolt locations for station. Pipe penetrations and station access clearances shall be dimensioned relative to the station centerline. The electrical ladder logic drawings

shall illustrate motor branch and liquid level control circuits to extent necessary to validate function and integration of circuits to form a complete working system.

### C. Operations and Maintenance Manuals

1. Operation shall be in accordance with written instructions provided by the pump station manufacturer. Comprehensive instructions supplied at time of shipment shall enable personnel to properly operate and maintain all equipment supplied. Content and instructions shall assume operating personnel are familiar with pumps, motors, piping and valves, but lack experience on exact equipment supplied. Three (3) bound copies are required.
2. Documentation shall be specific to the pump station supplied and collated in functional sections. Each section shall combine to form a complete system manual covering all aspects of equipment supplied by the station manufacturer. Support data for any equipment supplied by others, even if mounted or included in overall station design, shall be provided by those supplying the equipment. Instructions shall include the following as a minimum:
  - a. Functional description of each major component, complete with operating instructions.
  - b. Instructions for operating pumps and pump controls in all modes of operation.
  - c. Calibration and adjustment of equipment for initial start-up, replacement of level control components, or as required for routine maintenance.
  - d. Support data for commercially available components not produced by the station manufacturer, but supplied in accordance with the specifications, shall be supported by literature from the prime manufacturer and incorporated as appendices.
  - e. Electrical schematic diagram of the pump station circuits shall be in accordance with NFPA 70. Schematics shall illustrate, to the extent of authorized repair, pump motor branch, control and alarm system circuits including interconnections. Wire numbers and legend symbols shall be shown. Schematic diagrams for individual components, not normally repairable by the station operator, need not be included. Details for such parts shall not be substituted for an overall system schematic. Partial schematics, block diagrams, and simplified schematics shall not be provided in lieu of an overall system diagram.
  - f. Mechanical layout drawing of the pump station and components, prepared in accordance with good commercial practice, shall provide installation dimensions and location of all pumps, motors, valves and piping.
3. Operation and maintenance instructions which rely on vendor cut-sheets and literature which include general configurations, or require operating personnel to selectively read portions of the manual shall not be acceptable. Operation and maintenance instructions must be specific to equipment supplied in accordance with these specifications.

## 1.05 QUALITY ASSURANCE

### A. Manufacturer's Qualifications

1. Upon request from the engineer, the pump station manufacturer shall prove financial stability and ability to produce the station within the specified delivery schedules. Evidence of facilities, equipment and expertise shall demonstrate the manufacturer's commitment to long term customer service and product support.
2. Manufacturer must show proof of original product design and testing. Products violating intellectual property regulations shall not be allowed, as they may violate international law and expose the user or engineer to unintended liabilities. "Reverse-engineered" products fabricated to substantially duplicate the design of original product shall not be allowed, as they may contain substantial differences in tolerances and material applications addressed in the original design, which may contribute to product failure.
3. The term "pump manufacturer" or "pump station manufacturer" shall be defined as the entity which designs, machines, assembles, hydraulically tests and warrants the final product. Any entity that does not meet this definition will not be considered a "pump manufacturer" or "pump station manufacturer" and is not an acceptable supplier. For quality control reasons and future pump and parts availability, all major castings of the pump shall be sourced and machined in North America.

### B. Pump Performance Certifications

1. Solids Handling Capability
  - a. All internal passages, impeller vanes, and recirculation ports shall pass a 3-inch spherical solid. Smaller internal passages that create a maintenance nuisance or interfere with priming and pump performance shall not be permitted. Upon request from the engineer, manufacturer's certified drawings showing size and location of the recirculation port(s) shall be submitted for approval.
2. Reprime Performance
  - a. Consideration shall be given to the sanitary sewage service anticipated, in which debris is expected to lodge between the suction check valve and its seat, resulting in the loss of the pump suction leg, and siphoning of liquid from the pump casing to the approximate center line of the impeller. Such occurrence shall be considered normal, and the pump must be capable of automatic, unattended operation with an air release line installed.
  - b. During unattended operation, the pump shall retain adequate liquid in the casing to insure automatic repriming while operating at its rated speed in a completely open system. The need for a suction check valve or external priming device shall not be required.
  - c. Pump must reprime 18 vertical feet at the specified speed and impeller diameter. Reprime lift is defined as the static height of the pump suction above the liquid, while operating with only one-half of the liquid remaining in the pump casing.

The pump must reprime and deliver full capacity within five minutes after the pump is energized in the reprime condition. Reprime performance must be confirmed with the following test set-up:

- 1) A check valve to be installed down stream from the pump discharge flange. The check valve size shall be equal (or greater than) the pump discharge diameter.
  - 2) A length of air release pipe shall be installed between pump and the discharge check valve. This line shall be open to atmosphere at all times duplicating the air displacement rate anticipated at a typical pump station fitted with an air release valve.
  - 3) The pump suction check valve shall be removed. No restrictions in the pump or suction piping will prevent the siphon drop of the suction leg. Suction pipe configuration for reprime test shall incorporate a 2-foot minimum horizontal run, a 90 degree elbow and vertical run at the specified lift. Pipe size shall be equal to the pump suction diameter.
  - 4) Impeller clearances shall be set as recommended in the pump service manual.
  - 5) Repeatability of performance shall be demonstrated by testing five consecutive reprime cycles. Full pump capacity (flow) shall be achieved within five minutes during each cycle.
  - 6) Liquid to be used for reprime test shall be water.
3. Upon request from the engineer, certified reprime performance test results, prepared by the manufacturer, and certified by a registered professional engineer, shall be prepared and forwarded to the customer.

#### C. Factory System Test

1. All internal components including the pumps, motors, valves, piping and controls will be tested as a complete working system at the manufacturer's facility. Tests shall be conducted in accordance with Hydraulic Institute Standards at the specified head, capacity, rated speed and horsepower. Factory operational test shall simulate actual performance anticipated for the complete station.
2. Upon request from the engineer, the operational test may be witnessed by the engineer, and/or representatives of his choice, at the manufacturer's facility.

#### D. Manufacturer's Start-up Services

1. The manufacturer's technical representative shall inspect the completed installation, correct or supervise the correction of any defect or malfunction, and instruct operating personnel in the proper operation and maintenance of the equipment as described in Part 3 of this section.



## 1.06 MANUFACTURER'S WARRANTY

- A. The pump station manufacturer shall warrant all equipment to be of quality construction, free of defects in material and workmanship. A written warranty shall include specific details described below.
  - 1. In addition to defects in material and workmanship, fiberglass reinforced polyester station enclosures are warranted for sixty (60) months to be resistant to rust, corrosion, corrosive soils, effects of airborne contamination or physical failures occurring in normal service for the period of the pump station warranty.
  - 2. All other equipment, apparatus, and parts furnished shall be warranted for sixty (60) months, excepting only those items that are normally consumed in service, such as light bulbs, oils, grease, packing, gaskets, O-rings, etc. The pump station manufacturer shall be solely responsible for warranty of the station and all components.
- B. Components failing to perform as specified by the engineer, or as represented by the manufacturer, or as proven defective in service during the warranty period, shall be replaced, repaired, or satisfactorily modified by the manufacturer.
- C. It is not intended that the station manufacturer assume liability for consequential damages or contingent liabilities arising from failure of any vendor supplied product or part which fails to properly operate, however caused. Consequential damages resulting from defects in design, or delays in delivery are also beyond the manufacturer's scope of liability.
- D. Equipment supplied by others and incorporated into a pump station or enclosure is not covered by this limited warranty. Any warranty applicable to equipment selected or supplied by others will be limited solely to the warranty, if any, provided by the manufacturer of the equipment.
- E. This limited warranty shall be valid only when installation is made and use and maintenance is performed in accordance with manufacturer recommendations. A start-up report completed by an authorized manufacturer's representative must be received by manufacturer within thirty (30) days of the initial date the unit is placed into service. The warranty shall become effective on the date of acceptance by the purchaser or the purchaser's authorized agent, or sixty (60) days after installation, or ninety (90) days after shipment from the factory, whichever occurs first.

## PART 2 – PRODUCT

### 2.01 UNITARY RESPONSIBILITY

- A. In order to unify responsibility for proper operation of the complete pumping station, it is the intent of these Specifications that all system components be furnished by a single supplier (unitary source). The pumping station must be of standard catalog design, totally warranted by the manufacturer. Under no circumstances will a system consisting of parts compiled and assembled by a manufacturer's representative or distributor be accepted.

## 2.02 MANUFACTURER

- A. The pump station system integrator must be ISO 9001:2000 revision certified, with scope of registration including design control and service after sales activities.
- B. The specifications and project drawings depict equipment and materials manufactured by The Gorman-Rupp Company which are deemed most suitable for the service anticipated. It is not intended, however, to eliminate other products of equal quality and performance. The contractor shall prepare his bid based on the specified equipment for purposes of determining low bid. Award of a contract shall constitute an obligation to furnish the specified equipment and materials.
- C. After execution of the contract, the contractor may offer substitutions to the specified equipment for consideration. The equipment proposed for substitution must be superior in construction and performance to that specified in the contract, and the higher quality must be demonstrated by a list of current users of the proposed equipment in similar installations.
- D. In event the contractor obtains engineer's approval for equipment substitution, the contractor shall, at his own expense, make all resulting changes to the enclosures, buildings, piping or electrical systems as required to accommodate the proposed equipment. Revised detail drawings illustrating the substituted equipment shall be submitted to the engineer prior to acceptance.
- E. It will be assumed that if the cost to the contractor is less for the proposed substitution, then the contract price shall be reduced by an amount equal to the savings.

## 2.03 STATION ENCLOSURE

- A. The station enclosure shall contain and protect all pumps, interior piping, valves and associated controls. Enclosure shall incorporate the following design and service features:
  - 1. Access panels must be supplied on all sides. Location and size shall permit access for routine maintenance functions such as pump and motor inspection, drive belt adjustment, and pump clean-out. Non-hinged panels shall be secured with stainless steel tamper-proof hardware.
  - 2. A continuous hinge and latch shall be installed on at least two access panels. The hinged panels shall allow easy access to the electrical controls for frequent adjustments and inspections. A two-point mechanical latch assembly shall secure the panel at top and bottom. Latch handle locks shall be match keyed, requiring only one key to open all access panels.
  - 3. A vent in one access panel shall allow free air flow for enclosure ventilation.
  - 4. The complete station enclosure, less base, must be completely removable after disengaging reusable hardware. After disassembly, no portion of the enclosure (except electrical service entrance) shall project above the base surface to interfere with maintenance or endanger personnel.

5. Disassembly and removal of the enclosure shall require no more than two people working without assistance of lifting equipment.
- B. Station enclosure shall be manufactured of molded reinforced orthophthalic polyester resins with a minimum of 30% fiberglass, and a maximum of 70% resin. Resin fillers or extenders shall not be used.
1. Chopped glass fibers of 1-¼-inch average length shall be sprayed and rolled. Major design consideration shall be given to structural stability, corrosion resistance, and watertight integrity. The polyester laminates shall provide a balance of mechanical, chemical, and electrical properties to insure long life. They must be impervious to micro-organisms, mildew, mold, fungus, corrosive liquids, and gases which are expected to be present in the environment surrounding the wet well.
  2. All interior surfaces of the housing shall be coated with a polyester resin-rich finish providing maintenance-free service, abrasion resistance, and protection from sewage, greases, oils, gasoline, and other common chemicals.
  3. Outside surfaces of the enclosure shall be coated with gel-coat pigmented resin to insure long maintenance-free life and UV protection. Color used shall de-emphasize the presence of dirt, grease, etc.
- C. Station base shall be constructed of pre-cast, reinforced concrete encapsulated in a fiberglass mold. The design shall resist deformation of the structure during shipping, lifting, or handling. Base shall incorporate drainage provisions, and an opening sized to permit installation of piping and service connections to the wet well. After installation, the opening shall serve as a grout dam to be utilized by the contractor. The base shall incorporate anchor bolt recesses for securing the complete station to a concrete pad (supplied by the contractor) in accordance with the project plans.
- D. A blower mounted in the station roof shall be sized to exchange station air volume at least once every two minutes. Blower motor shall energize automatically at approximately 70 degrees F, and turn off at 55 degrees F. The blower motor control circuit shall incorporate a thermal-magnetic circuit breaker providing overcurrent and overload protection. Exhaust and inlet locations shall prevent the entrance of rain, snow, or debris.
- E. Station Heater
1. Pump station shall be provided with a 1300/1500 watt, 115 volt electric heater with cord and grounding plug. Ungrounded heaters shall not be acceptable.

*\*(Specifier note: Use this section for **Super T Series Pumps**)*

## 2.04 PUMP DESIGN

- A. Pumps shall be horizontal, self-priming centrifugal type, designed specifically for handling raw, unscreened, domestic sanitary sewage. Pump solids handling capability and performance criteria shall be in accordance with requirements listed under PART 1 - GENERAL of this section.

B. The pump manufacturer must be ISO 9001:2000 revision certified, with scope of registration including design control and service after sales activities.

C. Materials and Construction Features

1. Pump casing: Casing shall be cast iron Class 30 with integral volute scroll. Casing shall incorporate following features:
  - a. Mounting feet sized to prevent tipping or binding when pump is completely disassembled for maintenance.
  - b. Fill port coverplate, 3-½-inch diameter, shall be opened after loosening a hand nut/clamp bar assembly. In consideration for safety, hand nut threads must provide slow release of pressure, and the clamp bar shall be retained by detente lugs. A Teflon gasket shall prevent adhesion of the fill port cover to the casing.
  - c. Casing drain plug shall be at least 1-¼-inch NPT to insure complete and rapid draining.
  - d. Liquid volume and recirculation port design shall be consistent with performance criteria listed under PART 1 - GENERAL of this section.
2. Coverplate: Coverplate shall be cast iron Class 30. Design must incorporate following maintenance features:
  - a. Retained by hand nuts for complete access to pump interior. Coverplate removal must provide ample clearance for removal of stoppages, and allow service to the impeller, seal, wearplate or check valve without removing suction or discharge piping.
  - b. A replaceable wearplate secured to the coverplate by weld studs and nuts shall be AISI 1015 HRS.
  - c. In consideration for safety, a pressure relief valve shall be supplied in the coverplate. Relief valve shall open at 75-200 PSI.
  - d. Two O-rings of Buna-N material shall seal coverplate to pump casing.
  - e. Pusher bolt capability to assist in removal of coverplate. Pusher bolt threaded holes shall be sized to accept same retaining capscrews as used in rotating assembly.
  - f. Easy-grip handle shall be mounted to face of coverplate.
3. Rotating Assembly: A rotating assembly, which includes impeller, shaft, mechanical shaft seal, lip seals, bearings, sealplate and bearing housing, must be removable as a single unit without disturbing the pump casing or piping. Design shall incorporate following features:
  - a. Sealplate and bearing housing shall be cast iron Class 30. Separate oil filled cavities, vented to atmosphere, shall be provided for shaft seal and bearings.

Cavities must be cooled by the liquid pumped. Three lip seals will prevent leakage of oil.

- 1) The bearing cavity shall have an oil level sight gauge and fill plug check valve. The clear sight gauge shall provide easy monitoring of the bearing cavity oil level and condition of oil without removal of the fill plug check valve. The check valve shall vent the cavity but prevent introduction of moist air to the bearings.
  - 2) The seal cavity shall have an oil level sight gauge and fill/vent plug. The clear sight gauge shall provide easy monitoring of the seal cavity oil level and condition of oil without removal of the fill/vent plug.
  - 3) Double lip seal shall provide an atmospheric path providing positive protection of bearings, with capability for external drainage monitoring.
- b. Impeller shall be ductile iron, two-vane, semi-open, non-clog, with integral pump out vanes on the back shroud. Impeller shall thread onto the pump shaft and be secured with a lockscrew and conical washer.
  - c. Shaft shall be AISI 4140 alloy steel unless otherwise specified by the engineer, in which case AISI 17-4 pH stainless steel shall be supplied.
  - d. Bearings shall be anti-friction ball type of proper size and design to withstand all radial and thrust loads expected during normal operation. Bearings shall be oil lubricated from a dedicated reservoir. Pump designs which use the same oil to lubricate the bearings and shaft seal shall not be acceptable.
  - e. Shaft seal shall be oil lubricated mechanical type. The stationary and rotating seal faces shall be tungsten titanium carbide alloy. Each mating surface shall be lapped to within three light bands flatness (35 millionths of an inch), as measured by an optical flat under monochromatic light. The stationary seal seat shall be double floating by virtue of a dual O-ring design; an external O-ring secures the stationary seat to the sealplate, and an internal O-ring holds the faces in alignment during periods of mechanical or hydraulic shock (loads which cause shaft deflection, vibration, and axial/radial movement). Elastomers shall be viton. Cage and spring to be stainless steel. Seal shall be oil lubricated from a dedicated reservoir. The same oil shall not lubricate both shaft seal and shaft bearings. Seal shall be warranted in accordance with requirements listed under PART 1 - GENERAL of this section.
  - f. Pusher bolt capability to assist in removal of rotating assembly. Pusher bolt threaded holes shall be sized to accept same capscrews as used for retaining rotating assembly.
4. Adjustment of the impeller face clearance (distance between impeller and wearplate) shall be accomplished by external means.
    - a. Clearances shall be maintained by a four point external shimless coverplate adjustment system, utilizing a four collar and four adjusting screw design allowing for incremental adjustment of clearances by hand as required. Each of the four

points shall be lockable to prevent inadvertent clearance increases or decreases due to equipment vibration or accidental operator contact. The four point system also allows for equal clearance gaps at all points between the impeller and wear plate. Requirement of realignment of belts, couplings, etc., shall not be acceptable. Coverplate shall be capable of being removed without disturbing clearance settings. Clearance adjustment systems that utilize less than four points will not be considered.

- b. There shall be provisions for additional clearance adjustment in the event that adjustment tolerances have been depleted from the coverplate side of the pump. The removal of stainless steel shims from the rotating assembly side of the pump shall allow for further adjustment as described above
  - c. Clearance adjustment which requires movement of the shaft only, thereby adversely affecting seal working length or impeller back clearance, shall not be acceptable.
5. Suction check valve shall be molded Neoprene with integral steel and nylon reinforcement. A blow-out center shall protect pump casing from hydraulic shock or excessive pressure. Removal or installation of the check valve must be accomplished through the coverplate opening, without disturbing the suction piping. Sole function of check valve shall be to save energy by eliminating need to reprime after each pumping cycle. Pumps requiring a suction check valve to assist reprime will not be acceptable.
  6. Spool flanges shall be one-piece cast iron, class 30 fitted to suction and/or discharge ports. Each spool shall have one 1-¼-inch NPT and one ¼-inch NPT tapped hole with pipe plugs for mounting gauges or other equipment.

#### D. Serviceability

1. The pump manufacturer shall demonstrate to the engineer's satisfaction that consideration has been given to reducing maintenance costs.
2. No special tools shall be required for replacement of any components within the pump.

*\*(Specifier note: Use this section for **UltraV Series Pumps**)*

#### 2.05 PUMP DESIGN

- A. Pump shall be horizontal, self-priming centrifugal type, designed specifically for handling raw unscreened domestic sanitary sewage or industrial waste. Pump solids handling capability and performance criteria shall be in accordance with requirements listed under PART 1 - GENERAL of this section.
- B. The pump manufacturer must be ISO 9001:2000 revision certified, with scope of registration including design control and service after sales activities.

### C. Materials and Construction Features

1. Pump casing shall be cast iron Class 30 with integral volute scroll. Casing shall incorporate following features:
  - a. Mounting feet sized to prevent tipping or binding when pump is completely disassembled for maintenance.
  - b. Fill port coverplate, 3-½-inch diameter, shall be opened after loosening a positive lock clamp bar assembly. In consideration for safety, capscrew threads must provide slow release of pressure, and the clamp bar shall be retained by detente lugs. A non-metallic gasket shall prevent adhesion of the fill port cover to the casing while assuring a reliable seal.
  - c. Casing drain plug shall be at least 1-¼-inch NPT to insure complete and rapid draining.
  - d. Liquid volume and recirculation port design shall be consistent with performance criteria listed under PART 1 - GENERAL of this section.
2. Coverplate shall be cast iron Class 30. Design must incorporate the following maintenance features:
  - a. Retained by hand nuts for complete access to pump interior. Coverplate removal must provide ample clearance for removal of stoppages, and allow service to the impeller, seal, wearplate or check valve without removing suction or discharge piping.
  - b. A replaceable wearplate secured to the coverplate by weld studs and nuts shall be AISI 1015 HRS. Wearplate shall be self-cleaning design ensuring that debris is cleared away and does not collect on the impeller vanes.
  - c. In consideration for safety, a pressure relief valve shall be supplied in the coverplate. Relief valve shall open at 75-200 PSI.
  - d. Two O-rings of Buna-N material shall seal coverplate to pump casing.
  - e. Pusher bolt capability to assist in removal of coverplate. Pusher bolt threaded holes shall be sized to accept same retaining capscrews as used in rotating assembly.
  - f. Easy-grip handle shall be mounted to face of coverplate.
3. Rotating assembly, which includes impeller, shaft, mechanical shaft seal, lip seals, bearings, seal plate and bearing housing, must be removable as a single unit without disturbing the pump casing or piping. Design shall incorporate the following features:
  - a. Seal plate and bearing housing shall be cast iron Class 30. Anti-rotation ribs shall be cast into the sealplate to reduce internal wear and maximize component life. Separate oil filled cavities, vented to atmosphere, shall be provided for shaft

seal and bearings. Cavities must be cooled by the liquid pumped. Three lip seals will prevent leakage of oil.

- 1) The bearing cavity shall have an oil level sight gauge and fill plug check valve. The clear sight gauge shall provide easy monitoring of the bearing cavity oil level and condition of oil without removal of the fill plug check valve. The check valve shall vent the cavity but prevent introduction of moist air to the bearings.
  - 2) The seal cavity shall have an oil level sight gauge and fill/vent plug. The clear sight gauge shall provide easy monitoring of the seal cavity oil level and condition of oil without removal of the fill/vent plug.
  - 3) Double lip seal shall provide an atmospheric path providing positive protection of bearings, with capability for external drainage monitoring.
- b. Impeller shall be ductile iron, two vane, semi-open, non-clog, with integral pump out vanes on the back shroud. Impeller shall be statically or dynamically balanced. Impeller shall thread onto the pump shaft and be secured with a lock screw and conical washer.
  - c. Shaft shall be AISI 4140 alloy steel unless otherwise specified by the engineer, in which case AISI 17-4 pH stainless steel shall be supplied.
  - d. Bearings shall be anti-friction ball type of proper size and design to withstand all radial and thrust loads expected during normal operation. Bearings shall be oil lubricated from a dedicated reservoir. Pump designs which use the same oil to lubricate the bearings and shaft seal shall not be acceptable.
  - e. Shaft seal shall be oil lubricated mechanical type. The stationary and rotating seal faces shall be silicon carbide alloy. Each mating surface shall be lapped to within three light bands flatness (35 millionths of an inch), as measured by an optical flat under monochromatic light. The stationary seal seat shall be double floating by virtue of a dual O-ring design. An external O-ring secures the stationary seat to the sealplate, and an internal O-ring holds the faces in alignment during periods of mechanical or hydraulic shock (loads which cause shaft deflection, vibration, and axial/radial movement). Elastomers shall be viton; cage and spring to be stainless steel. Seal shall be oil lubricated from a dedicated reservoir. The same oil shall not lubricate both shaft seal and shaft bearings. Seal shall be warranted in accordance with requirements listed under PART 1 - GENERAL of this section.
  - f. Pusher bolt capability to assist in removal of rotating assembly. Pusher bolt threaded holes shall be sized to accept same capscrews as used for retaining rotating assembly.
4. Adjustment of the impeller face clearance (distance between impeller and wearplate) shall be accomplished by external means.
    - a. Clearances shall be maintained by a four point external shimless coverplate adjustment system, utilizing a four collar and four adjusting screw design allowing



for incremental adjustment of clearances by hand as required. Each of the four points shall be lockable to prevent inadvertent clearance increases or decreases due to equipment vibration or accidental operator contact. The four point system also allows for equal clearance gaps at all points between the impeller and wear plate. Requirement of realignment of belts, couplings, etc., shall not be acceptable. Coverplate shall be capable of being removed without disturbing clearance settings. Clearance adjustment systems that utilize less than four points will not be considered.

- b. There shall be provisions for additional clearance adjustment in the event that adjustment tolerances have been depleted from the coverplate side of the pump. The removal of stainless steel tabbed spacers from the rotating assembly side of the pump shall allow for further adjustment as described above.
  - c. Clearance adjustment which requires movement of the shaft only, thereby adversely affecting seal working length or impeller back clearance, shall not be acceptable.
5. An externally removable suction check valve shall be molded Neoprene with integral steel and nylon reinforcement. A blow-out center shall protect pump casing from hydraulic shock or excessive pressure. Removal or installation of the check valve must be accomplished from the top of pump without disturbing the suction piping or completely draining the casing. Sole function of check valve shall be to save energy by eliminating need to reprime after each pumping cycle. Pumps requiring a suction check valve to assist reprime will not be acceptable.
  6. Pump shall include flange kit consisting of two female 125# NPT cast iron class 30 flanges suitable for attachment to suction and discharge ports.
  7. Pump shall include flange kit consisting of two ASA spool flanges that shall be one piece cast iron class 30 suitable for attachment to suction and discharge ports. Each spool shall have one 1-¼-inch NPT and one ¼-inch NPT tapped hole with pipe plugs for mounting gauges or other equipment.

#### D. Serviceability

1. The pump manufacturer shall demonstrate to the engineer's satisfaction that consideration has been given to reducing maintenance costs.
2. No special tools shall be required for replacement of any components within the pump.

#### E. Drain Kit

1. Pumps to be supplied with a drain kit for ease of maintenance. The kit shall contain 10-foot length of reinforced plastic hose with a female quick connect fitting at one end, and factory installed drain fittings in each pump. Fittings include a stainless steel pipe nipple, stainless steel bushing, stainless steel ball valve and aluminum male quick connect fitting.

## F. Spare Parts Kit:

1. The following minimum spare parts shall be furnished with the pump station:
  - a. One pump mechanical seal
  - b. Required cover plate O-Ring(s)
  - c. One rotating assembly O-Ring(s)
  - d. One set of impeller clearance adjustment spacers

## 2.06 VALVES AND PIPING

- A. Check Valve: Each pump shall be equipped with a full flow type check valve capable of passing a 3-inch spherical solid. Valve shall be constructed with flanged ends and fitted with an external lever and torsional spring. Valve seat shall be constructed of stainless steel, secured to the body to ensure concentricity, sealed by an O-ring, and shall be replaceable. The valve body shall be cast iron incorporating a clean-out port large enough to allow removal and/or replacement of the valve clapper without removing valve or piping from the line. Valve clapper shall have a molded neoprene seating surface incorporating low pressure sealing rings. Valve hinge pin and internal hinge arm shall be stainless steel supported on each end in brass bushings. Shaft nut shall have double O-rings which shall be easily replaceable without requiring access to interior of valve body. All internal hardware shall be stainless steel. Valve shall be rated at 175 PSI water working pressure, 350 PSI hydrostatic test pressure. Valves other than full flow type or valves mounted in such a manner that prevents the passage of a 3-inch spherical solid shall not be acceptable.
- B. Plug Valve: A 3-way plug valve must allow either or both pumps to be isolated from the force main. The plug valve shall be non-lubricated, tapered type. Valve body shall be semi-steel with flanged end connections drilled to 125 pound standard. The drip-tight shutoff plug shall be mounted in stainless steel bearings, and shall have a resilient facing bonded to the sealing surface. Valve shall be operated with a single lever actuator providing lift, turn, and reseal action. The lever shall have a locking device to hold the plug in the desired position.
- C. Automatic Air Release Valves
  1. Each pump shall be equipped with an automatic air release valve designed to vent air to atmosphere during initial priming or unattended repriming cycles. Upon completion of the priming or repriming cycle, the valve shall automatically close operating solely on discharge pressure to prevent excess recirculation. A visible indication of valve closure shall be evident. Valves which connect to the suction line or rely on vacuum pumps shall not be acceptable.
  2. The air release valve shall be constructed of UV-inhibiting, high impact composite polyester containing not less than 30% glass-filler. The valve body shall incorporate an internal passageway that allows all debris to pass through the valve chamber between operational cycles, thus making the valve self-cleaning upon sequential cycles. The valve diaphragms shall be Buna-N, Fluorocarbon or EPDM, and shall incorporate a polyester mesh sufficient to withstand 250 PSI of pressure. Diaphragm materials of lesser-rated durability will not be deemed equal.

3. The vertical valve plunger shall be constructed of Acetal and at least 20% PTFE fluorocarbon filler (DuPont Teflon or equivalent). The independent, dual diaphragms and single, vertical valve plunger shall incorporate a media fluid that passes through an orifice and separates the actions of each. This media fluid will impart sufficient energy for each diaphragm to act on the other to cause a metered stroke, allowing for predictable mechanical movement, thus opening and closing the valve smoothly, preventing chatter and harsh ramming forces. Valves with a single horizontal shaft or that do not incorporate straight-through passageways or media-limiting orifices will not be acceptable. The valve "seat" shall permit a prescribed bypass of the liquid being pumped to ensure that the valve does not become hydraulically locked in submerged discharge piping configurations.
4. The valve shall employ an externally-adjustable restrictor for applications below four feet of static discharge head. Valves having no means to accurately adjust their action, or which require spring selection and lubrication are unacceptable. Being mechanically maintenance-free, provisions for clearing debris in the internal passageway normally associated with valves of this type are incorporated in the valve design and are accessible with only normal hand tools.
5. The valve body shall incorporate passageways having minimal constrictions and no directional course changes integral to the body of the valve. The inlet shall be 1-inch NPT female and the discharge outlet shall be 1-¼-inch NPT female, assuring that any debris that makes its way through the valve body will have unobstructed passage back to the source. Valves having smaller throughput, bends or turns that restrict or impede flow and create pockets or traps for debris shall not be acceptable. The valve shall be mounted horizontally, 90 degrees to the vertical plunger by means of an integral mounting bracket.
6. The valve shall be able to operate on applications ranging from four to 400-feet of water column without the need for adjustment or interchange of springs or other parts.
7. Connection of the air release valves to pump station piping shall include stainless steel fittings.

#### D. Gauge Kit

1. A gauge kit shall be supplied for each pump. Suction pressure must be monitored by a glycerin-filled compound gauge, and discharge pressure by a glycerin-filled pressure gauge. Gauges to be at least 4-inches in diameter, graduated in feet water column. Rated accuracy shall be 1% of full scale reading. Compound gauge shall be graduated -34 to +34 feet water column minimum. Pressure gauge to be graduated 0 to 140-feet water column minimum.
2. Gauges to be factory mounted on a resilient panel with frame assembly secured to pumps or piping. Gauge installations shall be complete with all hoses and stainless steel fittings, including a shutoff valve for each gauge line at the point of connection to suction and discharge pipes.

## E. Piping

1. Flanged header pipe shall be centrifugally cast, ductile iron, complying with ANSI/AWWA A21.51/C115 and class 53 thickness.
2. Flanges shall be cast iron class 125 and Comply with ANSI B16.1.
3. Pipe and flanges shall be threaded and suitable thread sealant applied before assembling flange to pipe.
4. Bolt holes shall be in angular alignment within  $\frac{1}{2}$  degree between flanges. Flanges shall be faced with a gasket finish having concentric grooves a minimum of 0.01 inch deep by approximately 0.03 inch wide, with a minimum of three grooves on any given surface spaced a maximum of  $\frac{1}{4}$ -inch apart.

F. Supports and Thrust Blocks: Contractor must insure all pipes connected to the pump station are supported to prevent piping loads from being transmitted to pumps or station piping. Pump station discharge force main piping shall be anchored with thrust blocks where shown on the contract drawings.

## G. Portable Pump Discharge Connection

1. The station header pipe shall incorporate a 2-way plug valve to permit emergency access to the pump station force main after isolation of the pumps. Valve body shall be cast iron with flanged end connections drilled to 125 pound standard. The plug valve shall be non-lubricated type, furnished with a drip-tight shutoff plug mounted in stainless steel or Teflon over phenolic bearings, and shall have a resilient facing bonded to the sealing surface.
2. The bypass connection shall be accessible behind the hinged access panel on the wet well side of the station enclosure and shall terminate with a male OPW type quick connect fitting.

## 2.07 DRIVE UNIT

A. Motors (Note: Maximum motor frame size is 326T open drip-proof.)

Motor will have to be sized for the system designed for by designer.

1. Pump motors shall be \_\_\_ HP, horizontal ODP, 1,800 RPM, NEMA design B with cast iron frame with copper windings, induction type, with class F insulation and 1.15 Service Factor for normal starting torque and low starting current characteristics, suitable for continuous service. The motors shall not overload at the design condition or at any head in the operating range as specified. Motors shall be suitable for operation using the utility power available specified in part 1 of this section.
2. Motors shall be tested in accordance with provisions of ANSI/IEEE Std. 112, Method B.

## B. Drive Transmission

1. Power to pumps transmitted V-belt drive assemblies. The sheave/belt combination shall provide the speed ratio needed to achieve the specified pump operating conditions.
2. Each drive assembly shall utilize at least two V-belts providing minimum a combined safety factor of 1.5. Single belt drives or systems with a safety factor of less than 1.5 are not acceptable. Computation of safety factors shall be based on performance data published by the drive manufacturer.
3. Precise alignment tolerances of the drive assemblies shall be achieved by means of a belt/sheave laser alignment system resulting in the reduction of vibration, accelerated wear, and premature failure.
4. The pump manufacturer shall submit power transmission calculations which document the following:
  - a. Ratio of pump/motor speed.
  - b. Pitch diameter of driver and driven sheaves.
  - c. Number of belts required per drive.
  - d. Theoretical horsepower transmitted per belt, based on vendor's data.
  - e. Center distance between pump and motor shafts.
  - f. Arc-length correction factor applied to theoretical horsepower transmitted.
  - g. Service factor applied to established design horsepower.
  - h. Safety factor ratio of power transmitted/brake horsepower required.
5. Pump drives to be enclosed on all sides by a guard constructed of fabricated steel or combination of materials including expanded, perforated, or solid sheet metal. No opening to a rotating member shall exceed ½-inch.
  - a. Guards must be completely removal without interference from any unit component, and shall be securely fastened and braced to the unit base.
  - b. Metal to be free from burrs and sharp edges. Structural joints shall be continuously welded. Rivet spacing on panels shall not exceed five inches. Tack welds shall not exceed four inch spacing.
  - c. The guard shall be finished with one coat of gray W.R. non-lift primer and one coat of orange acrylic alkyd W.R. enamel in accordance with section 3, Color Definitions of ANSI 253.1; Safety Color Code for Marking Physical Hazards.

## 2.08 Finish

- A. Pumps, piping, and exposed steel framework shall be cleaned prior to painting. Exposed surfaces to be coated with one coat gray W.R. non-lift primer and one coat white acrylic alkyd W.R. enamel. Paint shall be low VOC, alkyd based, high solids, semi-gloss white enamel for optimum illumination enhancement, incorporating rust inhibitive additives. The finish coat shall be 1.0 to 1.2 MIL dry film thickness (minimum), resistant to oil mist exposure, solvent contact, and salt spray. The factory finish shall allow for over-coating and touch up after final installation.

## 2.09 ELECTRICAL CONTROL COMPONENTS

- A. The pump station control panel will be tested as an integral unit by the pump station manufacturer. The control panel shall also be tested with the pump station as a complete working system at the pump station manufacturer's facility.
- B. Panel Enclosure
  - 1. Electrical control equipment shall be mounted within a common NEMA 1 stainless steel, dead front type control enclosures. Doors shall be hinged and sealed with a neoprene gasket and equipped with captive closing hardware. Control components shall be mounted on removable steel back panels secured to enclosure with collar studs.
  - 2. All control devices and instruments shall be secured to the sub-plate with machine screws and lockwashers. Mounting holes shall be drilled and tapped; self-tapping screws shall not be used to mount any component. All control devices shall be clearly labeled to indicate function.
- C. Branch Components
  - 1. All motor branch and power circuit components shall be of highest industrial quality. The short circuit current rating of all power circuit devices shall be a tested combination or evaluated per the National Electrical Code Article 409. The lowest rated power circuit component shall be the overall control panel short circuit rating and shall not be less than the fault current available. The minimum control panel rating shall not be less than 10 kA, rms symmetrical. Control assemblies operating at 120 volts nominal or less may be provided with transformers which limit the fault current and may be rated less than the minimum required short circuit rating.
  - 2. Circuit Breakers and Operating Mechanisms
    - a. A properly sized heavy duty circuit breaker shall be furnished for each pump motor. The circuit breakers must be sealed by the manufacturer after calibration to prevent tampering.
    - b. An operating mechanism installed on each motor circuit breaker shall penetrate the control panel door. A padlockable operator handle shall be secured on the exterior surface. Interlocks must prevent opening the door until circuit breakers are in "OFF" position. An additional mechanism(s) shall be provided on the circuit breaker permitting the breaker to be operated and/or locked with the control panel door in the open position.
  - 3. Motor Starters for Motors Up to 30 HP
    - a. An open frame, across-the-line, NEMA rated magnetic starter with under-voltage release, and overload protection on all three phases, shall be furnished for each pump motor. Starters of NEMA size 1 and above shall allow addition of at least two auxiliary contacts. Starters rated "O", "OO", or fractional size are not acceptable. Power contacts to be double-break type made of cadmium oxide

silver. Coils to be epoxy molded for protection from moisture and corrosive atmospheres. Contacts and coils shall be easily replaceable without removing the starter from its mounted position. Each starter shall have a metal mounting plate for durability.

Use for Motors 30 HP and Above:

**\*(REDUCED VOLTAGE SOLID STATE STARTERS [RVSS] WITH PUMP CONTROL AND BYPASS in lieu of standard Motor Starters.)**

4. Starter: A reduced voltage, solid state motor starter shall be furnished for each pump motor. The starter construction shall be modular with separately replaceable power and control sections. The power section shall consist of six back-to-back SCR's rated 208 to 480 volts, 50/60 hertz. The SCR's shall have a minimum repetitive peak inverse voltage rating of 1400 volts at 480 volts. The enclosed operating temperature range shall be 0 to 40 degrees C at altitudes up to 2000 meters without derating.
  - a. Starting Modes: Starting modes shall be selectable soft start, current limit, or full voltage. Soft starting the pump shall include an adjustable initial torque value of 0 to 90 %. The acceleration ramp shall be adjustable from 0 to 30 seconds. The starter shall include a selectable kick start providing a current pulse at start. Kick start level shall be adjustable from 0 to 90% of locked rotor torque. Kick start time shall be adjustable from 0 to 2 seconds. Current limit mode shall provide means for limiting the starting current to a programmable value between 50 and 600% of full load current. Full voltage start shall provide across the line starting with a ramp time of less than 0.25 seconds.
  - b. Pump Control Mode: Ramp time will be dependent on pump torque requirements. The starter shall provide smooth acceleration and deceleration, which approximates the flow rate of a centrifugal pump. The starter's microcomputer shall analyze motor variables and generate control commands, which will minimize surges in the system. Pump stop time shall be adjustable from 0 to 120 seconds. Pump control provides reduced hydraulic shock.
  - c. Bypass: When the start ramp time is complete, the starter shall energize an integral bypass contactor. When in the bypass mode, the bypass contactor shall carry the motor load to minimize internal heating in the electrical enclosure.
  - d. Protection: The starter shall include protective features: Communication fault, control temperature, excess starts/hour, stall, jam, line fault, open gate, overload, overvoltage, phase reversal, power loss, underload, undervoltage, shorted SCR, open bypass and voltage unbalance.
    - 1) An integral electronic overload relay equipped with thermal memory shall be included and shall utilize three phase current sensing. Adjustments shall include trip current, service factor and 10, 15, 20 or 30 trip class.
    - 2) Jam trip shall be adjustable 0-1,000% of the nominal motor current with a delay time adjustment of 0-99 seconds.

- 3) Stall protection senses that the motor is not up-to-speed at end of ramp and will shut down after a user-selected delay time has elapsed. Stall delay shall be adjustable from 0-10 seconds.
  - 4) Fault diagnostics shall be displayed on the starter and shall include temperature fault, line fault, open gate and power loss.
  - e. Display: The starter shall include a keypad and display on the front of the control module. The display is equipped with a built-in four line, 16 character backlit LCD. The LCD displays metering, faults and parameter settings in English. Faults will display in English and fault code. A fault buffer will store the last five faults. Metering capabilities shall include: Three phase current, three phase voltage, power factor, motor thermal usage, wattmeter, kilowatt hours, and elapsed time meter. Digital parameter adjustments shall be made using the keypad.
  - f. Door Mounted Display: Each starter shall be furnished with a display and keypad mounted to the door of the control panel. The door mounted display will duplicate the functions of the starter display and allow the operator to monitor or change parameters without opening the control panel door.
5. Overload Relays
- a. Overload relays shall be solid-state block type, having visual trip indication with trip-free operation. Electrically resetting the overload will cause one (1) normally open and one (1) normally closed isolated alarm/control contact to reset, thus re-establishing a control circuit. Trip setting shall be governed by solid-state circuitry and adjustable current setting. Trip classes shall be 10, 15 and 20. Additional features to include phase loss protection, selectable jam/stall protection and selectable ground fault protection.
  - b. A reset pushbutton, mounted through the control panel door, shall permit resetting the overload relays without opening the door.
6. Phase Monitor
- a. The control panel shall be equipped to monitor the incoming power and shut down the pump motors when required to protect the motor(s) from damage caused by phase reversal, phase loss, voltage unbalance, high voltage, and low voltage. An adjustable time delay shall be provided to minimize nuisance trips. The motor(s) shall automatically restart, following an adjustable time delay, when power conditions return to normal.
7. Phase Monitor
- a. The control panel shall be equipped to monitor the incoming power and shut down the pump when required to protect the motor(s) from damage caused by voltage less than 83% of nominal. The motor(s) shall automatically restart when power conditions return to normal.



8. Transient Voltage Surge Suppressor
  - a. The control panel shall be equipped with a transient voltage surge suppressor to minimize damage to the pump motors and control from transient voltage surges. The suppressor shall utilize thermally protected silicon-oxide varistors encapsulated in a non-conductive housing. Mechanical indicators shall be provided on each phase to indicate protection has been lost. The suppressor shall have a surge current rating of 100,000 Amps per phase and a 100kA interrupting rating.
9. Pump Start Delay:
  - a. The control circuit for pump #2 shall be equipped with a time delay to prevent simultaneous motor starts.

#### D. Control Circuit

1. A normal duty thermal-magnetic circuit breaker shall protect all control circuits by interrupting control power.
2. Pump mode selector switches shall permit manual start or stop of each pump individually, or permit automatic operation under control of the liquid level control system. Manual operation shall override all shutdown systems, except the motor overload relays. Selector switches to be oil-tight design with contacts rated NEMA A300 minimum.
3. Pump alternation shall be integral to the liquid level controller. Provisions for automatic alternation or manual selection shall also be integral to the liquid level controller.
4. Six digit elapsed time meter (non-reset type) shall be connected to each motor starter to indicate total running time of each pump in "hours" and "tenths of hours". An integral pilot light shall be wired in parallel to indicate that the motor is energized and should be running.
5. A high pump temperature protection circuit shall override the level control and shut down the pump motor(s) when required to protect the pump from excessive temperature. A thermostat shall be mounted on each pump casing and connected to a pump shutdown circuit. If casing temperature rises to a level sufficient to cause damage, the thermostat causes the shutdown circuit to interrupt power to the motor. A visible indicator, mounted through the control panel door shall indicate motor stopped due to high pump temperature. The motor shall remain locked out until the pump has cooled and circuit has been manually reset. Automatic reset of this circuit is not acceptable.
6. A duplex ground fault receptacle providing 115 VAC, 60 Hz, single phase current, will be mounted on the side of the control enclosure. Receptacle circuit shall be protected by a 15 ampere thermal-magnetic circuit breaker.
7. The lift station shall be equipped with a 3 KVA stepdown transformer to supply 115 volt, AC, single phase for the control and auxiliary equipment. The primary

and secondary side of the transformer to be protected by a thermal magnetic circuit breaker, sized to meet the power requirements of the transformer. An operating mechanism shall penetrate the control panel door and a padlockable operator handle shall be secured on the exterior surface. Interlocks must prevent opening the door until circuit breakers are in "OFF" position. An additional mechanism(s) shall be provided on the circuit breaker permitting the breaker to be operated and/or locked with the control panel door in the open position.

8. Wiring

- a. The pump station, as furnished by the manufacturer, shall be completely wired, except for power feed lines to the branch circuit breakers and final connections to remote alarm devices.

Dry contacts shall be provided to monitor the following alarms through a separate telemetry system. They shall be, but not be limited to, high and low level alarms, pump high temperature motor thermal overload, pump failure, seal failure, if applicable, and station power.

- b. All wiring, workmanship, and schematic wiring diagrams shall comply with applicable standards and specifications of the National Electric Code (NEC).
- c. All user serviceable wiring shall be type MTW or THW, 600 volts, color coded as follows:

- 1) Line and Load Circuits, AC or DC power.....Black
- 2) AC Control Circuit Less Than Line Voltage.....Red
- 3) DC Control Circuit.....Blue
- 4) Interlock Control Circuit, from External Source.....Yellow
- 5) Equipment Grounding Conductor.....Green
- 6) Current Carrying Ground.....White
- 7) Hot With Circuit Breaker Open.....Orange

- d. Control circuit wiring inside the panel, with exception of internal wiring of individual components, shall be 16 gauge minimum, type MTW or THW, 600 volts. Power wiring to be 14 gauge minimum. Motor branch wiring shall be 10 gauge minimum.
- e. Motor branch and other power conductors shall not be loaded above the temperature rating of the connected termination. Wires must be clearly numbered at each end in conformance with applicable standards. All wire connectors in the control panel shall be ring tongue type with nylon insulated shanks. All wires on the sub-plate shall be bundled and tied. All wires extending from components mounted on door shall terminate at a terminal block mounted on the back panel. All wiring outside the panel shall be routed through conduit.
- f. Control wires connected to door mounted components must be tied and bundled in accordance with good commercial practice. Bundles shall be made flexible at the hinged side of the enclosure. Adequate length and flex shall allow the door to swing full open without undue stress or abrasion. Bundles shall be held on each side of hinge by mechanical fastening devices.

9. Conduit
  - a. Factory installed conduit shall conform to following requirements:
    - 1) All conduit and fittings to be UL listed.
    - 2) Liquid tight flexible metal conduit to be constructed of smooth, flexible galvanized steel core with smooth abrasion resistant, liquid tight polyvinyl chloride cover.
    - 3) Conduit to be supported in accordance with articles 346, 347, and 350 of the National Electric Code.
    - 4) Conduit shall be sized according to the National Electric Code.
10. Grounding
  - a. Station manufacturer shall ground all electrical equipment inside the pump station to the control panel back plate. All paint must be removed from the grounding mounting surface before making final connection.
  - b. The contractor shall provide an earth driven ground connection to the pump station at the main grounding lug in accordance with the National Electric Code (NEC).
11. Equipment Marking
  - a. Permanent corrosion resistant name plate(s) shall be attached to the control and include following information:
    - 1) Equipment serial number
    - 2) Control panel short circuit rating
    - 3) Supply voltage, phase and frequency
    - 4) Current rating of the minimum main conductor
    - 5) Electrical wiring diagram number
    - 6) Motor horsepower and full load current
    - 7) Motor overload heater element
    - 8) Motor circuit breaker trip current rating
    - 9) Name and location of equipment manufacturer
  - b. Control components shall be permanently marked using the same identification keys shown on the electrical diagram. Labels shall be mounted adjacent to device being identified.
  - c. Switches, indicators, and instruments mounted through the control panel door shall be labeled to indicate function, position, etc. Labels shall be mounted adjacent to, or above the device.

## 2.10 LIQUID LEVEL CONTROL (Float Switch Type)

- A. The level control system shall start and stop pump motors in response to changes in wet well level. It shall be a mercury free float switch type with floats to be secured to a

vertical pipe in the wet well. Rising and falling liquid level in the wet well causes switches within the floats to open and close, providing start and stop signals to the remainder of the level control system.

- B. The level control system shall start and stop the pumps in accordance to the wet well level. Upon operator selection of automatic operation, a float switch shall start one pump motor when water rises to the "lead pump start level". When the water is lowered to the "lead pump stop level", the system shall stop this pump. These actions shall constitute one pumping cycle. Should the water continue to rise, an additional float switch will start the second pump after reaching the "lag pump start level" so that both pumps operate together. Both pumps shall stop at the same "all pumps off level". Circuit design in which application of power to the lag pump motor starter is contingent upon completion of the lead pump circuit shall not be acceptable.
- C. The level control system shall work in conjunction with an alternator relay to select first one pump, then the second pump, to run as "Lead" pump. Alternation will occur at the end of each pumping cycle.
- D. Float switches shall be supplied for installation by the contractor. Each float shall contain a mercury free switch sealed in a polypropylene housing, with 30-feet of power cord, and polypropylene mounting hardware. A PVC or stainless steel mounting pipe shall be furnished by the contractor to secure the switches in the wet well.
- E. A junction box shall be supplied for installation in the wet well by the contractor. Junction box shall be NEMA 4X, non-corrosive type incorporating terminal blocks match-marked to terminals in the control panel.
- F. A separate float switch shall be used to alert maintenance personnel to a high water and low water level in the wet well. Should the water level rise to the "high water alarm" level, the float switch shall energize a 115-volt AC circuit for an external alarm device. An indicator, visible from front of control panel, shall indicate high level condition exists. The alarm signal shall maintain until wet well level is lowered and alarm circuit manually reset.
- G. An alarm silence switch shall provide maintenance personnel a means to de-energize the external alarm device while corrective actions are under way. After silencing the alarm, manual reset of the alarm signal shall provide automatic reset of the alarm silence relay.
- H. Alarm Light (External)
  - 1. Station manufacturer will supply one 115 VAC alarm light fixture with vapor-tight shatter resistant red globe, conduit box, and mounting base. The design must prevent rain water from collecting in the gasketed area of the fixture, between the base and globe. The alarm light will be shipped loose for installation by the contractor.
- I. Alarm Horn (External)
  - 1. Station manufacturer will supply one 115 VAC weatherproof alarm horn with projector, conduit box, and mounting base. The design must prevent rain water

from collecting in any part of the horn. The alarm horn will be shipped loose for installation by the contractor.

## **PART 3 - EXECUTION**

### **3.01 EXAMINATION**

- A. Contractor shall off-load equipment at installation site using equipment of sufficient size and design to prevent injury or damage. Station manufacturer shall provide written instruction for proper handling. Immediately after off-loading, contractor shall inspect complete pump station and appurtenances for shipping damage or missing parts. Any damage or discrepancy shall be noted in written claim with shipper prior to accepting delivery. Validate all station serial numbers and parts lists with shipping documentation. Notify the manufacturer's representative of any unacceptable conditions noted with shipper.

### **3.02 INSTALLATION**

- A. Install, level, align, and lubricate pump station as indicated on project drawings. Installation must be in accordance with written instructions supplied by the manufacturer at time of delivery.
- B. Suction pipe connections are vacuum tight. Fasteners at all pipe connections must be tight. Install pipe with supports and thrust blocks to prevent strain and vibration on pump station piping. Install and secure all service lines (level control, air release valve or pump drain lines) as required in wet well.
- C. Check motor and control data plates for compatibility to site voltage. Install and test the station ground prior to connecting line voltage to station control panel.
- D. Prior to applying electrical power to any motors or control equipment, check all wiring for tight connection. Verify that protective devices (fuses and circuit breakers) conform to project design documents. Manually operate circuit breakers and switches to ensure operation without binding. Open all circuit breakers and disconnects before connecting utility power. Verify line voltage, phase sequence and ground before actual start-up.
- E. After all anchor bolts, piping and control connections are installed, completely fill the grout dam in the pump station base with non-shrink grout.

### **3.03 FIELD QUALITY CONTROL**

#### **A. Operational Test**

- 1. Prior to acceptance by owner, an operational test of all pumps, drives, and control systems shall be conducted to determine if the installed equipment meets the purpose and intent of the specifications. Tests shall demonstrate that all equipment is electrically, mechanically, structurally, and otherwise acceptable; it is safe and in optimum working condition; and conforms to the specified operating characteristics.
- 2. After construction debris and foreign material has been removed from the wet well, contractor shall supply clear water volume adequate to operate station through

several pumping cycles. Observe and record operation of pumps, suction and discharge gage readings, ampere draw, pump controls, and liquid level controls. Check calibration of all instrumentation equipment, test manual control devices, and automatic control systems. Be alert to any undue noise, vibration or other operational problems.

#### B. Manufacturer's Start-up Services

1. Coordinate station start-up with manufacturer's technical representative. The representative or factory service technician will inspect the completed installation. He will calibrate and adjust instrumentation, correct or supervise correction of defects or malfunctions, and instruct operating personnel in proper operation and maintenance procedures.

#### 3.04 CLEANING

- A. Prior to acceptance, inspect interior and exterior of pump station for dirt, splashed material or damaged paint. Clean or repair accordingly. Remove from the job site all tools, surplus materials, scrap and debris.

#### 3.05 PROTECTION

- A. The pump station should be placed into service immediately. If operation is delayed, drain water from pumps and piping. Open motor circuit breakers and protect station controls and interior equipment from cold and moisture. Station is to be stored and maintained per manufacturer's written instructions.

**END OF SECTION**

**SECTION 15113.1  
RESILIENT SEAT  
GATE VALVES**

**PART 1.00 NOTICE**

The General Conditions, Special Conditions and all other herein bound and accompanying documents are part of these specifications and of the Contract. Submission of proposal implies that the Bidder is fully conversant with all requirements of all above-mentioned documents.

**PART 2.00 SCOPE OF THE WORK**

The work in this section consists of furnishing all materials, accessories, equipment, tools, transportation, services, labor, and performing all operations to execute the gate valves work for this project, all as indicated on the drawings, approved shop drawings and as herein specified. Provide all gate valves work in place complete.

**PART 3.00 SHOP DRAWINGS**

Before commencing work, submit for the Engineer's approval, shop drawings and illustrations as required for gate valves work. Refer to the GENERAL CONDITIONS for detailed information regarding shop drawings requirements.

**PART 4.00 JOB CONDITIONS**

Refer to the GENERAL CONDITIONS for detailed information regarding job conditions requirements.

**PART 5.00 DESCRIPTION**

- 5.01 VALVE CASTINGS: Approved, all iron castings, made from superior quality iron.
- 5.02 ALL VALVES: Open in same direction as those installed on Owner's existing equipment. All valves shall be mechanical joint for underground valves and flange for above ground valves, with accessories, resilient wedged, epoxy coated inside and out. They shall be domestic brand name with four (4) no roll tee head bolts and eight (8) tee head bolts.
- 5.03 All gate valves are to be iron body, bronze mounted, non-rising stem for underground valves and rising stem for above ground valves unless otherwise noted on the drawings.
- 5.04 Valves sixteen inches (16") and larger shall be furnished with either bevel or spur gearing with grease case and bypass valve. Bevel geared valves shall have rollers, track and scrapers.

- 5.05 Except as otherwise noted on drawings, all valves shall conform to requirements of AWWA C500, latest revision. Valves, three-inches (3") to twelve-inches (12"), nominal size; suitable for pressures of at least two hundred (200) psi.

#### **PART 6.00 ADJUSTABLE VALVE BOXES**

Provide all underground valves with screw top, adjustable metal boxes, approximately five-inches (5") in diameter, constructed so that removable cover will not be thrown out by travel over same. Provide boxes with approved hoods at base of lower section to section to relieve any strain superimposed on valve bonnet. Valve boxes shall be cast iron, twenty-four inches (24") to thirty-six inches (36") adjustable with lid.

#### **PART 7.00 FOUNDATION**

- 7.01 Set valves securely on solidly compacted ground.
- 7.02 Height of valve and its foundations shall conform to height of connecting pipe so that there is no strain on joints.

#### **PART 8.00 TAPPING SLEEVES AND CROSSES, CUT-IN SLEEVES, TAPPING VALVES**

- 8.01 Provide tapping sleeves and gate valves, where shown on drawings. Tapping sleeves shall be Ford Fast All Stainless Tapping Sleeve, J.C.M. 432 all stainless, Rockwell 633, Romas S.S.T w/ S.S. Flange. Other approved brands are Ford, FTS, and JCM-422. Waterous 500 RW gate valves for use with tapping sleeves shall be used. Tapping valve shall have 8" x 16" x 16" supporting base. Tapping sleeve shall have 8" x 16" x 16" supporting base and 8" x 16" x 16" backer block.
- 8.02 Tapping sleeves, cut-in sleeves, tapping valves, and cut-in valves shall be installed where shown on the drawing or as directed by the Engineer.
- 8.03 The above listed items shall comply with all applicable AWWA Specifications.
- 8.04 The tapping valve and cut-in valves shall also comply with the Specifications for gate valves.

END OF SECTION



**SECTION 15210  
DUCTILE IRON WATER MAINS**

**PART 1.00 NOTICE**

The General Conditions, Special Conditions and all other herein bound and accompanying documents are part of these Specifications and of the Contract. Submission of proposal implies that the Bidder is fully conversant with all requirements of all above-mentioned documents.

**PART 2.00 DUCTILE IRON PIPE**

- 2.01 All push-on joint and mechanical joint ductile iron pipe for water mains shall conform to Standards of ANSI/AWWA C150/A21.50 and ANSI/AWWA C151/A21.51, latest revision.
- 2.02 All ductile iron pipe shall be at least 18-feet long with wall thickness as determined by ANSI/AWWA C150/A21.50. Pipe shall be adequate for the rated working pressure plus a surge allowance of 100 psi, 3-foot earth cover over pipe, standard allowances for water hammer. Pipe wall thickness shall in no case be less than the following:

| <u>NOMINAL PIPE<br/>DIAMETER</u><br>(INCHES) | <u>PRESSURE<br/>CLASS</u> |
|--|---------------------------|
| 3 - 12                                       | 350                       |
| 14 - 48                                      | 250                       |
| 24   | 200                       |
| 30 - 60                                      | 150                       |

- 2.03 Provide manufacturer's certificate of compliance with specification for each shipment of pipe.
- 2.04 The Contractor shall purchase all ductile iron pipe from approved, reputable, responsible manufacturers. Furnish to the Engineer duplicate copies of orders for pipes under this contract.
- 2.05 All ductile iron pipe shall be lined with cement mortar as per ANSI A21.4, latest revision.
- 2.06 See drawings for locations and extent.

**PART 3.00 SPECIAL FITTINGS**

- 3.01 ANSI A21.10 - Fittings 3-inches to 48-inches.
- 3.02 ANSI A21.11 - Rubber gasket joints for ductile iron pressure pipe and fittings.
- 3.03 All fittings shall be cement mortar lined as per ANSI A21.4, latest revision.

3.04 Weights for mechanical joint fittings will be based on those published by Tyler Pipe for mechanical joint short body, Class 350 fittings. Concrete blocking for fittings shall be included in the unit price bid per foot of water main.

**PART 4.00 JOINTS AND COUPLINGS**

4.01 Mechanical joints shall be stuffing box type, with gasket, cast iron gland and cast iron bolts as per ANSI A21.11. Complete joints as per manufacturer’s recommendations and with all applicable sections of this specification.

- A. Before installation, clean spigot and opposing socket free of foreign matter and loose rust with a wire brush to insure proper seating of gasket. Immediately prior to installation brush said spigot, opposing socket and gasket with clean soapy water for final cleaning and lubricate gasket as it is forced into its retaining space.
- B. After inserting bolts through flange and gland, tighten same uniformly until torque on each bolt is within the following range:

| <u>BOLT SIZE</u> | <u>RANGE OF TORQUE</u> | <u>BOLT SIZE</u> | <u>RANGE OF TORQUE</u> |
|------------------|------------------------|------------------|------------------------|
| (INCHES)         | (FEET - POUNDS)        | (INCHES)         | (FEET - POUNDS)        |
| 5/8              | 45 - 60                | 1                | 100 - 200              |
| 3/4              | 75 - 90                | 1 1/4            | 120 - 150              |

- C. As bolts are tightened, bring gland up toward flange evenly and maintain approximately same distance between gland and face of flange at all points around socket. Accomplish this by partially tightening bottom bolt first, then the top bolts, next cycle until all bolts are within above specified range to torques. If effective sealing is not obtained at maximum torque indicated above, disassemble joint, clean same thoroughly and reassemble. Over-stressing bolts to force tight seal is prohibited.

4.02 Push-on joints shall be pipe joints of type and employing single, molded rubber gasket to effect joint seal, as per ANSI A21.11, latest revision.

- A. Before installation, clean spigot end and opposing socket free of all foreign matter and loose rust with a wire brush, to provide proper seating of gasket.
- B. Before inserting spigot end of pipe into bell end, apply proper lubricant to gasket and spigot end. Make joints as per manufacturer’s instructions.

4.03 Push-on joint with restrained joints shall be same as Part 4.02 above except special American Fast-Grip gasket shall be used for additional restraint. American flex ring joint shall be used for uncased directional bore.

END OF SECTION

# **APPENDIX**

## **STANDARD DETAILS SANITARY SEWER SYSTEM MUNFORD, TENNESSEE**

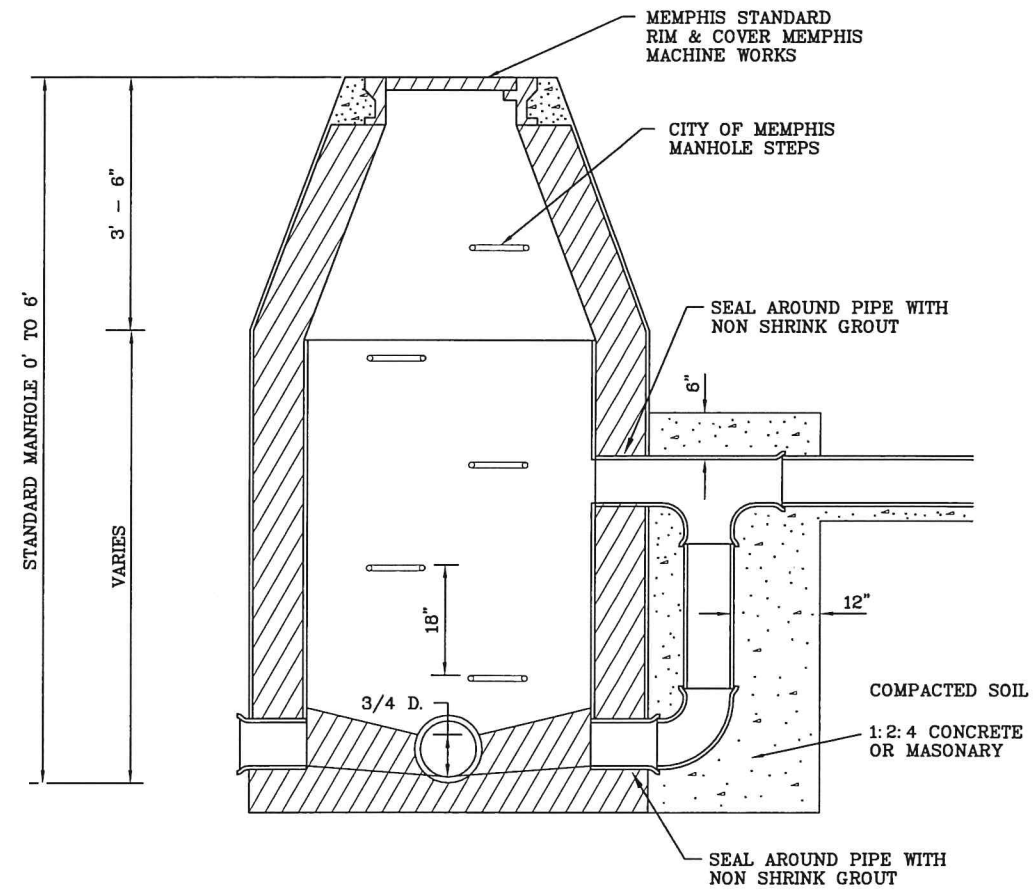

PRECAST CONCRETE MANHOLE DETAIL

SCALE: NONE

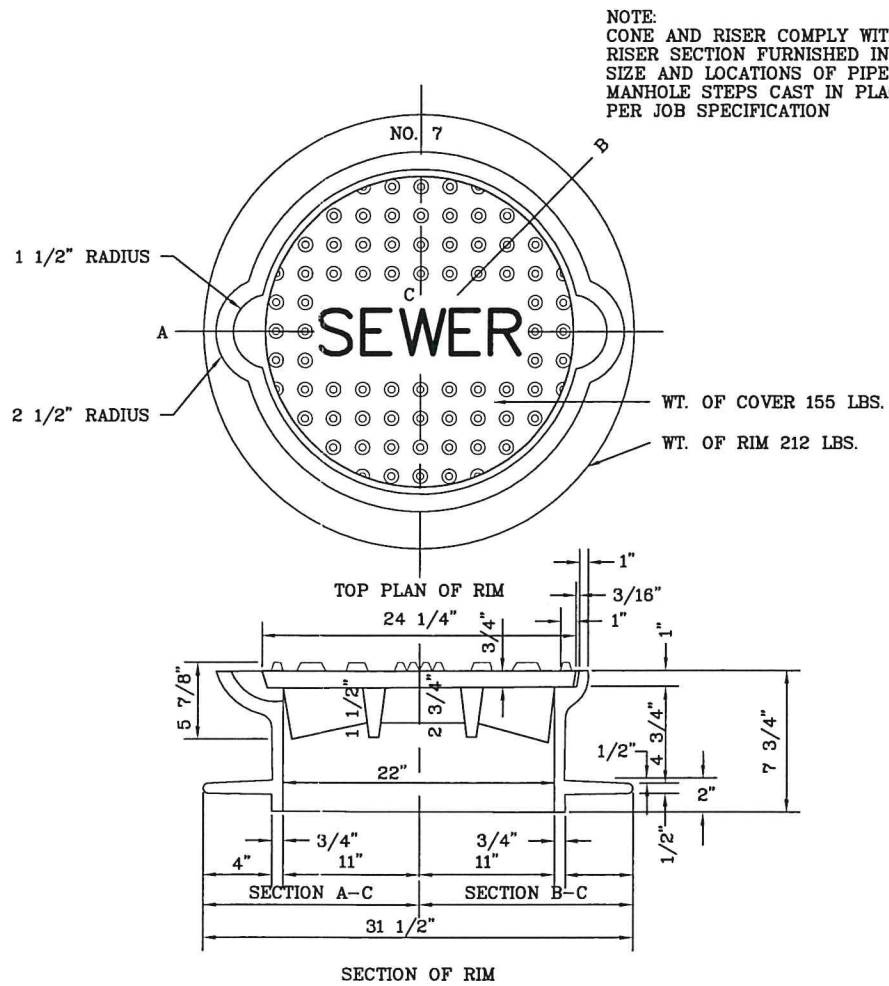

STANDARD MANHOLE RIM AND COVER

MEMPHIS MACHINE WORKS  
MEMPHIS, TENNESSEE  
SCALE: NONE

NOTE:  
CONE AND RISER COMPLY WITH ASTM SPECIFICATION C478  
RISER SECTION FURNISHED IN LENGTHS OF 16", 32", 48"  
SIZE AND LOCATIONS OF PIPE CUTOUTS AS REQUIRED  
MANHOLE STEPS CAST IN PLACE AS SHOWN OR OMITTED  
PER JOB SPECIFICATION

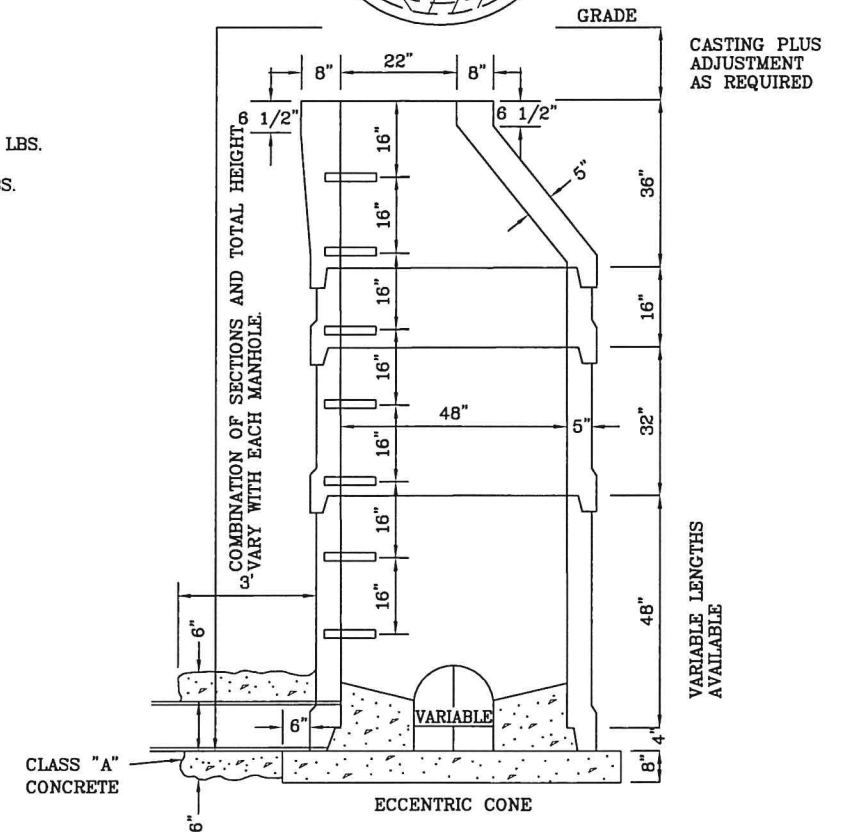
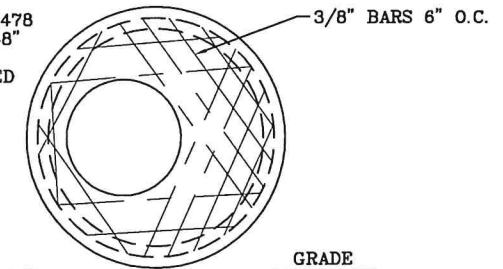

48" PRECAST CONCRETE MANHOLE

SCALE: NONE

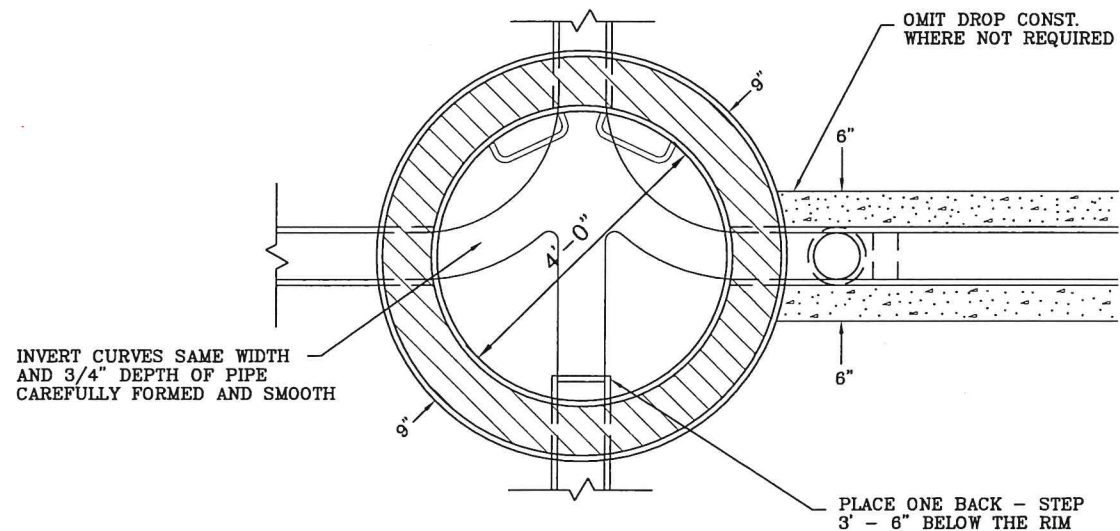

MANHOLE TOP TO BE FLUSH WITH TOP OF GROUND UNLESS OTHERWISE NOTED.



*Kenneth R. King*  
5-31-11

STANDARD DETAILS  
SANITARY SEWER SYSTEM  
MUNFORD, TENNESSEE

|                      |   |                     |
|----------------------|---|---------------------|
| CHECKED<br>K KING    |  | SCALE<br>AS SHOWN   |
| LICENSE NO.<br>12309 |   | SHEET NO.<br>1 OF 6 |
| DESIGNED<br>K E C.   |   | DWG. NO.<br>4528    |
| DRAWN<br>K E C.      |   | DATE<br>05/24/2011  |

#4 REBARS  
AT 6" O.C.

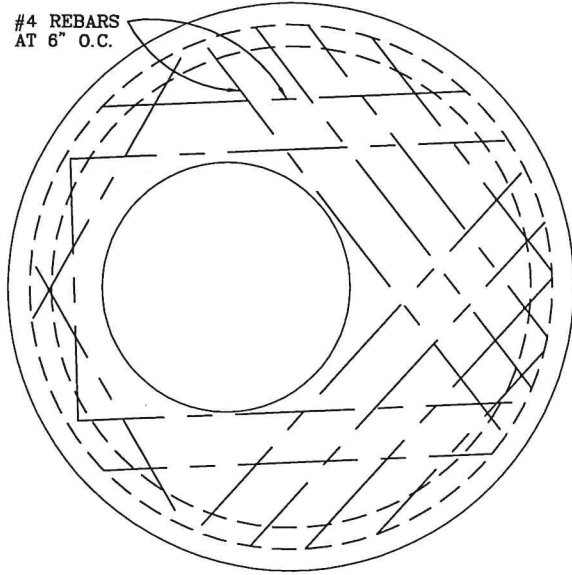

PLAN VIEW

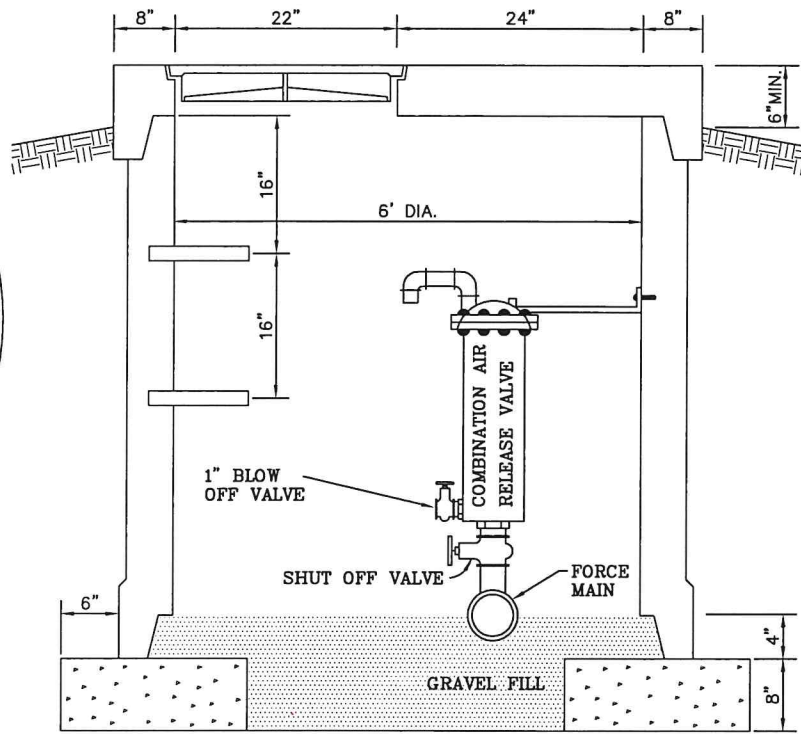

SECTION

**DETAIL  
COMBINATION AIR RELEASE VALVE  
AND MANHOLE**

SCALE: NONE

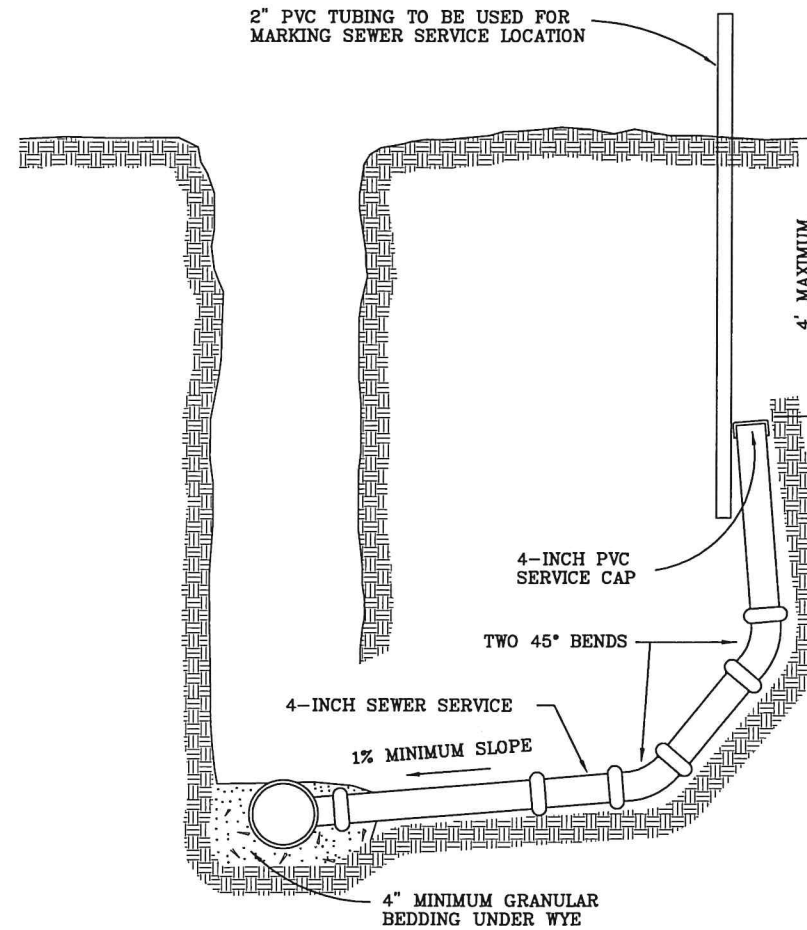

**DETAIL  
HOUSE CONNECTION**

SCALE: NONE

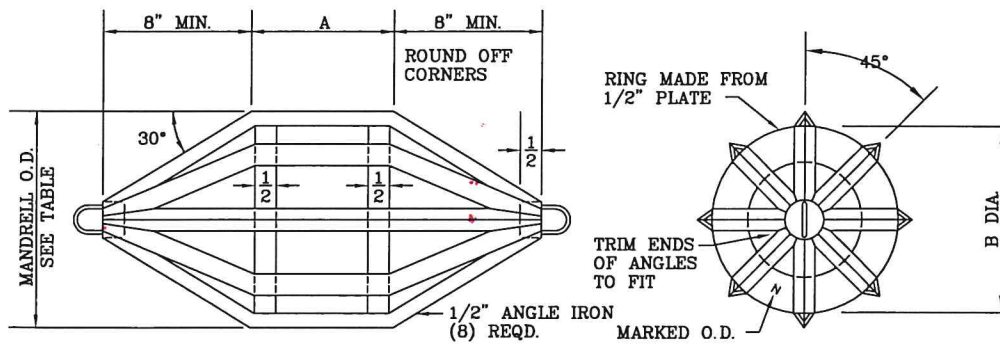

SIDE OR TOP VIEW

END VIEW

| STAMPED IDENTIFICATION | O.D.   |       | B        |       | A  | OVERALL RUNNER | OVERALL CENTER ROD |
|------------------------|--------|-------|----------|-------|----|----------------|--------------------|
|                        | 5% TOL | LIMIT | 7.5% TOL | LIMIT |    |                |                    |
| D-3034 DR-35 15"       | 13.43  | 12.43 | 13.08    | 12.08 | 15 | 19             | 41                 |
| D-3034 DR-35 12"       | 10.98  | 9.98  | 10.69    | 9.69  | 12 | 16             | 38                 |
| D-3034 DR-35 10"       | 9.22   | 8.22  | 8.98     | 7.98  | 10 | 14             | 36                 |
| D-3034 DR-35 8"        | 7.37   | 6.37  | 7.18     | 6.18  | 8  | 12             | 34                 |
| D-3034 DR-35 6"        | 5.50   | 4.50  | 5.36     | 4.36  | 6  | 10             | 32                 |

**PVC DEFLECTION TESTING MANDREL**

SCALE: NONE

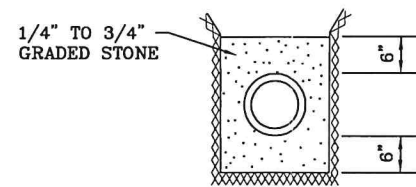

OVER 20' OF COVER

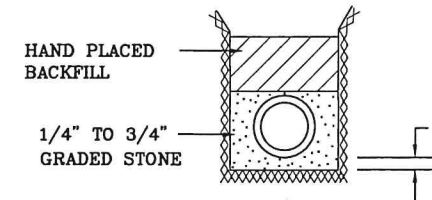

3' TO 20' OF COVER

**TYPICAL SECTION - BEDDING FOR SEWER - PVC PIPE**

SCALE: NONE  
SEE PLANS FOR TYPE AND DEPTHS OF PIPE

**GRADING TABLE FOR CLASS A  
AND CLASS B BEDDING**

| GRADING | TOTAL PER CENT BY WEIGHT, PASSING SIEVES |        |        |       |      |       |       |        |         |
|---------|--|--------|--------|-------|------|-------|-------|--------|---------|
|         | 2-1/2"                                   | 2"     | 1-1/2" | 1"    | 3/4" | 3/8"  | NO. 4 | NO. 16 | NO. 100 |
| A       | 100                                      | 95-100 |        |       |      | 35-65 |       |        | 0-10    |
| B       |  | 100    | 95-100 | 65-95 |      | 35-55 | 15-45 |        | 0-15    |

**KENNETH R. KING**  
REGISTERED ENGINEER  
AGRICULTURE  
STATE OF TENNESSEE  
5-31-11

**STANDARD DETAILS  
SANITARY SEWER SYSTEM  
MUNFORD, TENNESSEE**

|                      |  |                     |
|----------------------|--|---------------------|
| CHECKED<br>K. KING   |  | SCALE<br>AS SHOWN   |
| LICENSE NO.<br>12309 |  | SHEET NO.<br>2 OF 6 |
| DESIGNED<br>K.E.C.   |  | DWG. NO.<br>4529    |
| DRAWN<br>K.E.C.      |  | DATE<br>05/24/2011  |

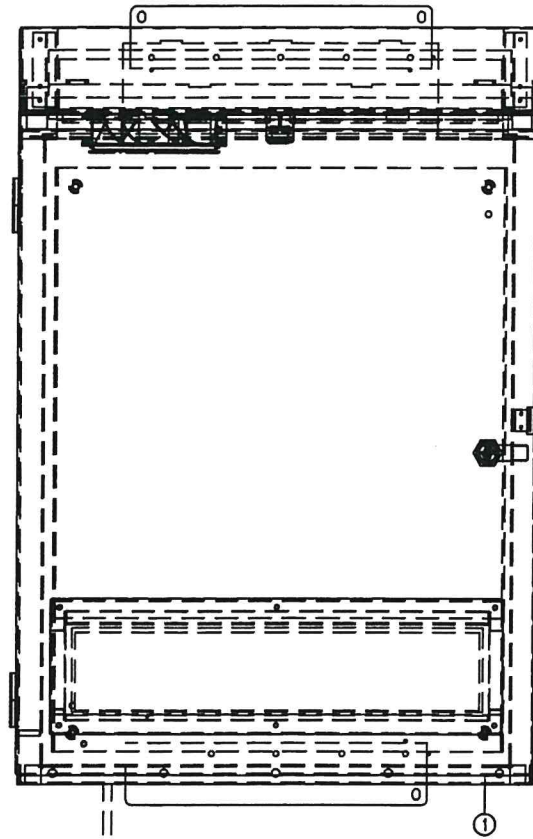

HELIX ANTENNA CABLE SHOULD BE INSTALLED IN WATER TIGHT FLEXIBLE CONDUIT, CONNECTED TO 2 1/2" ANTENNA MAST, INSTALLED INSIDE MAST UP TO ANTENNA. SEE SHEET E001 FOR WEATHER PROOFING INSTRUCTIONS.

RTU CONTROL PANEL EXTERIOR DETAIL

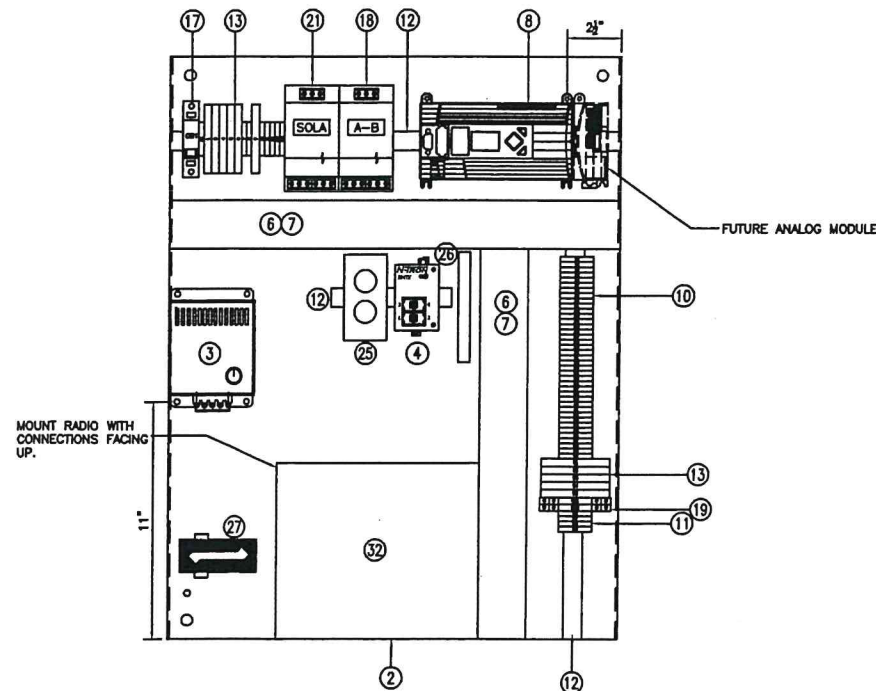

RTU CONTROL PANEL INTERIOR DETAIL

CONTROL PANEL BILL OF MATERIALS

| NO. | QTY.   | DESCRIPTION  | PART NO.      |
|-----|--------|--|---------------|
| 1   | 1      | HOFFMAN WEATHERFLO TYPE 3R VENTED ENCLOSURE W/FAN, 35"X24"X12"     | WF 10LP       |
| 2   | 1      | HOFFMAN SUBPANEL   | A30P24        |
| 3   | 1      | HOFFMAN ELECTRIC HEATER - 200 WATT, 115 VAC                        | D-AH2001A     |
| 4   | 1      | N-TRON ETHERNET SWITCH, 4 -10/100BASETX RJ-45 PORTS                | 304TX-N       |
| 5   | 1      | PATCH CORD, 3', RJ45M TO RJ45M, CAT 5e, STRAIGHT PIN               | Z3304006-03   |
| 6   | 6      | PANDUIT, 2"X4" WHITE WIREWAY                                       | F2X4WH6       |
| 7   | 6      | PANDUIT, 2" WIRE DUCT COVER  | C2WH6         |
| 8   | 1      | ALLEN-BRADLEY, MICROLOGIX 1400 PROCESSOR                           | 1766-L32AWA   |
| 9   |        |  |               |
| 10  | AS REQ | ALLEN-BRADLEY, TERMINALS, GRAY                                     | 1492-J4       |
| 11  | AS REQ | ALLEN-BRADLEY, TERMINALS, BLUE (FOR 24 VDC)                        | 1492-J4B      |
| 12  | 2      | ALLEN-BRADLEY, SYMETRICAL STEEL DIN RAIL                           | 199-DR1       |
| 13  | AS REQ | ALLEN-BRADLEY, FUSED TERMINAL BLOCK WITH NEON BLOWN FUSE INDICATOR | 1492-H4       |
| 14  | 2      | ALLEN-BRADLEY, TERMINAL END BARRIER                                | 1492-EBJ3     |
| 15  | 2      | ALLEN-BRADLEY, FUSED TERMINAL END BARRIER                          | 1492-N37      |
| 16  | 4      | ALLEN-BRADLEY, HEAVY DUTY TERMINAL END ANCHOR                      | 1492-EAHJ35   |
| 17  | 1      | ALLEN-BRADLEY, CIRCUIT BREAKER, 15 AMP, SINGLE POLE                | 1489-AIC150   |
| 18  | 1      | ALLEN-BRADLEY POWER SUPPLY, 2.5 AMP, 120VAC INPUT/24VDC OUTPUT     | 1606-XL60D    |
| 19  | 2      | ALLEN-BRADLEY TERMINAL RELAY                                       | 700-HLT1L1    |
| 20  |        |  |               |
| 21  | 1      | SOLA, SURGE SUPPRESSOR   | STV25K-10S    |
| 22  |        |  |               |
| 23  | 20     | GOULD, 2 AMP 120 VAC GLASS FUSE                                    | GGC2          |
| 24  | 10     | GOULD, 5 AMP 120 VAC GLASS FUSE                                    | GGC5          |
| 25  | 1      | ALLEN-BRADLEY, DIN RAIL MOUNT DUPLEX GFCI RECEPTACLE, 15 AMP       | 1492-REC15G   |
| 26  | 1      | SIEMENS GROUND BAR   | GB10          |
| 27  | 1      | ESTEEM, LIGHTNING ARRESTOR, N-f/N-f, 125-1000 MHZ                  | AA161         |
| 28  | 1      | ESTEEM, COAX CABLE, RG8, N-m/N-m,                                  | AA237         |
| 29  | 1      | ESTEEM CABLE, RS232C, 9F/25M,                                      | AA061         |
| 30  | 2      | ESTEEM, SCOTCH VINYL MASTIC PADS, 6 1/2" X 4 1/2"                  | AA241         |
| 31  | 1      | ESTEEM, ANTENNA, 150-174 MHz, 8dBd, YAGI-DIRECTIONAL, N-f          | AA202M        |
| 32  | 1      | ESTEEM, 192M, 150-174 MHz, NARROW BAND, 19.2 KBPS(4 WATTS)         | 192M-4W       |
| 33  | 1      | ESTEEM, 192M RADIO POWER SUPPLY 90-264 VAC, 12 VDC, 3A             | AA174         |
| 34  | 1      | ESTEEM CABLE, LMR195, TNC-m/n-M, 2.5 FT                            | AA234LMR      |
| 35  | 1      | ESTEEM ADAPTER, EST/MICROLOGIX, 1000-1200                          | AC0315021     |
| 36  | 1      | ALLEN-BRADLEY, MICROLOGIX 1200 MINIDIN TO 9-PIN CABLE              | 1761-CBL-PM02 |
| 37  | 1      | GENDER CHANGER, DB9M X DB9M  |               |
| 38  | 1      | NULL MODEM ADAPTER, DB9F X DB9M                                    |               |
| 39  | 1      | APC 500 VA UNINTERRUPTIBLE POWER SUPPLY                            | BK500         |
| 40  |        |  |               |

GENERAL NOTES:

- ITEMS LISTED ON THE BILL OF MATERIALS SHALL BE FURNISHED AS LISTED, NO EXCEPTIONS.
- PANELS SHALL BE SHOP FABRICATED. FIELD FABRICATION OF PANELS WILL NOT BE PERMITTED.
- LINE NUMBER CODE:
- WIRE NUMBER CODE (NOT ORIGINATING FROM PLC I/O):
- WIRE NUMBER CODE (ORIGINATING FROM PLC I/O):
- EXAMPLE OF WIRE NUMBER WOULD BE 20609L. THIS WOULD INDICATE THAT THIS WIRE IS IN CONTROL PANEL CP-2, WIRING DIAGRAM 06, LINE 20609 AND WOULD BE THE SECOND WIRE TO ORIGINATE FROM THE LINE.
- WHEN NO WIRE NUMBER IS SHOWN USE ALLEN BRADLEY TERMINAL JUMPERS, P/N 1492-N39.
- ANALOG SIGNAL, COMMUNICATION, 120 VAC POWER AND 24 VAC POWER WIRING SHALL ONLY BE RUN IN CONDUIT DEDICATED TO EACH SERVICE. NO MIXING OF SERVICES IN CONDUIT SHALL BE PERMITTED.
- TWO-WIRE ANALOG CABLE SHALL BE 100% SHIELDED 18 GAGE BELDEN #8760.
- THREE-WIRE ANALOG CABLE SHALL BE 100% SHIELDED 18 GAGE BELDEN #8770.
- INTERNAL PANEL DISCRETE AND POWER WIRING SHALL BE OLYMPIC 16 GAGE TEFLON EXTRUDED TYPE-E PART #312. FIELD WIRING SHALL BE AS PER DIVISION 16 OF THE SPECIFICATIONS.
- WIRE COLOR CODE:  
 BLACK = INTERNAL PANEL POWER WIRING  
 RED = INPUT WIRING  
 PURPLE = OUTPUT WIRING  
 BLUE = 24 VDC(+) WIRING  
 BLUE W/ WHITE STRIPE = 24 VDC(-) WIRING  
 WHITE = NEUTRAL  
 GREEN = GROUND  
 YELLOW = WIRE HAS EXTERNAL POWER SOURCE
- WIRE, CABLE, TERMINAL AND FUSE LABELS SHALL CONSIST OF THE COMPLETE WIRE NUMBER MATCHING EXACTLY THE WIRE NUMBER SHOWN ON THE WIRING DIAGRAMS, CUSTOM PRINTED ON A SINGLE PRESSURE SENSITIVE, SELF ADHESIVE TAPE WHICH WRAPS THE ENTIRE CIRCUMFERENCE OF THE WIRE OR CABLE. HAND WRITING OR COMBINING MULTIPLE LABELS TO MAKE THE WIRE NUMBER SHALL NOT BE PERMITTED.

STANDARD DETAILS  
 RTU CONTROL PANEL  
 INTERNAL & EXTERNAL DETAILS  
 TELEMETRY SYSTEM  
 WASTEWATER PUMPING STATION  
 MUNFORD, TENNESSEE

|                       |   |                     |
|-----------------------|---|---------------------|
| CHECKED<br>N/A        | <p>INCORPORATED<br/>       PROFESSIONAL ENGINEERS<br/>       MEMPHIS, TENNESSEE</p> | SCALE<br>AS SHOWN   |
| LICENSE NO.<br>N/A    |   | SHEET NO.<br>3 OF 6 |
| DESIGNED<br>R. GAINES |   | DWG. NO.<br>4529    |
| DRAWN<br>R. GAINES    |   | DATE<br>05/24/2011  |

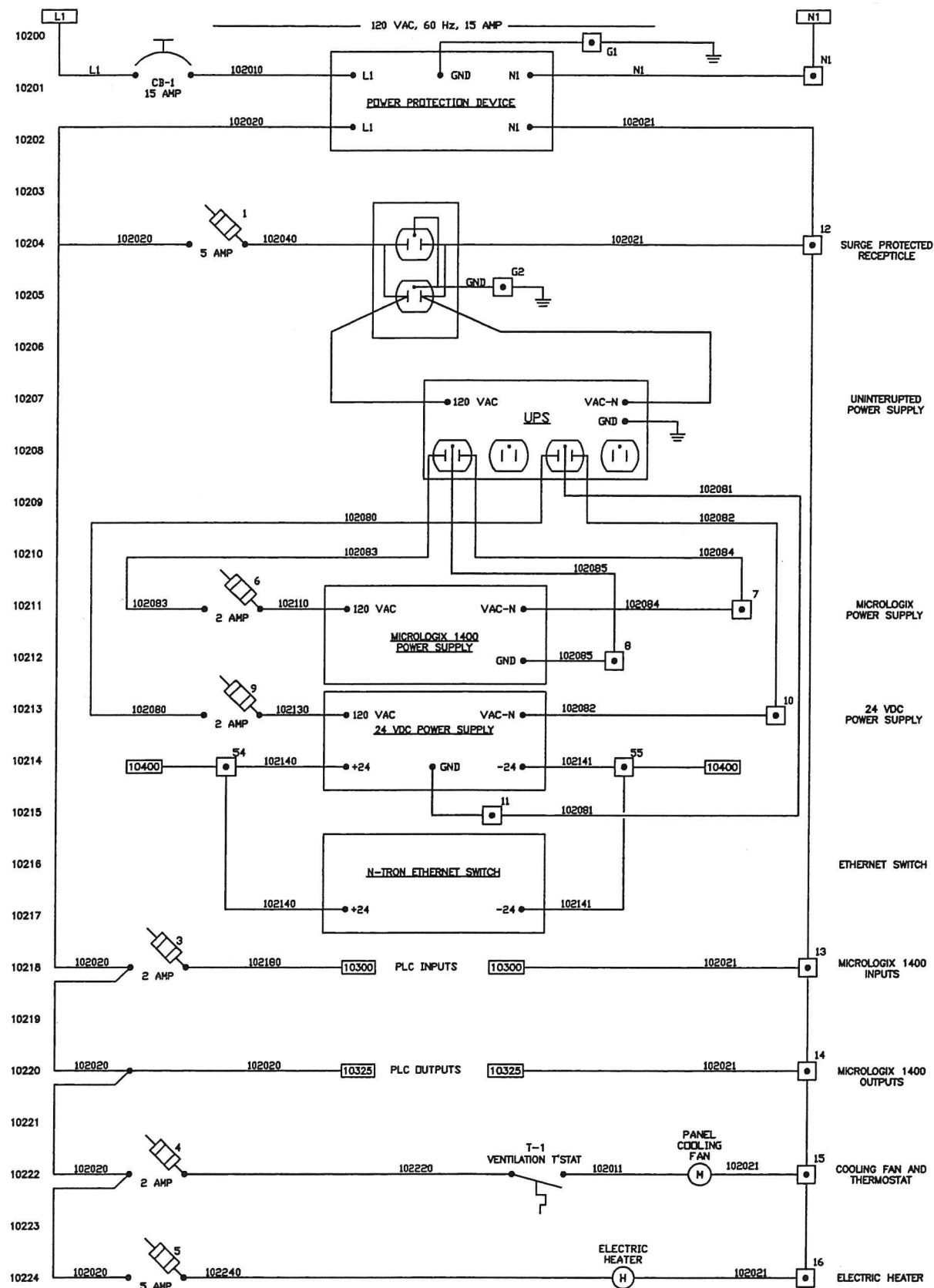

10200  
10201  
10202  
10203  
10204  
10205  
10206  
10207  
10208  
10209  
10210  
10211  
10212  
10213  
10214  
10215  
10216  
10217  
10218  
10219  
10220  
10221  
10222  
10223  
10224

10225  
10226  
10227  
10228  
10229  
10230  
10231  
10232  
10233  
10234  
10235  
10236  
10237  
10238  
10239  
10240  
10241  
10242  
10243  
10244  
10245  
10246  
10247  
10248  
10248

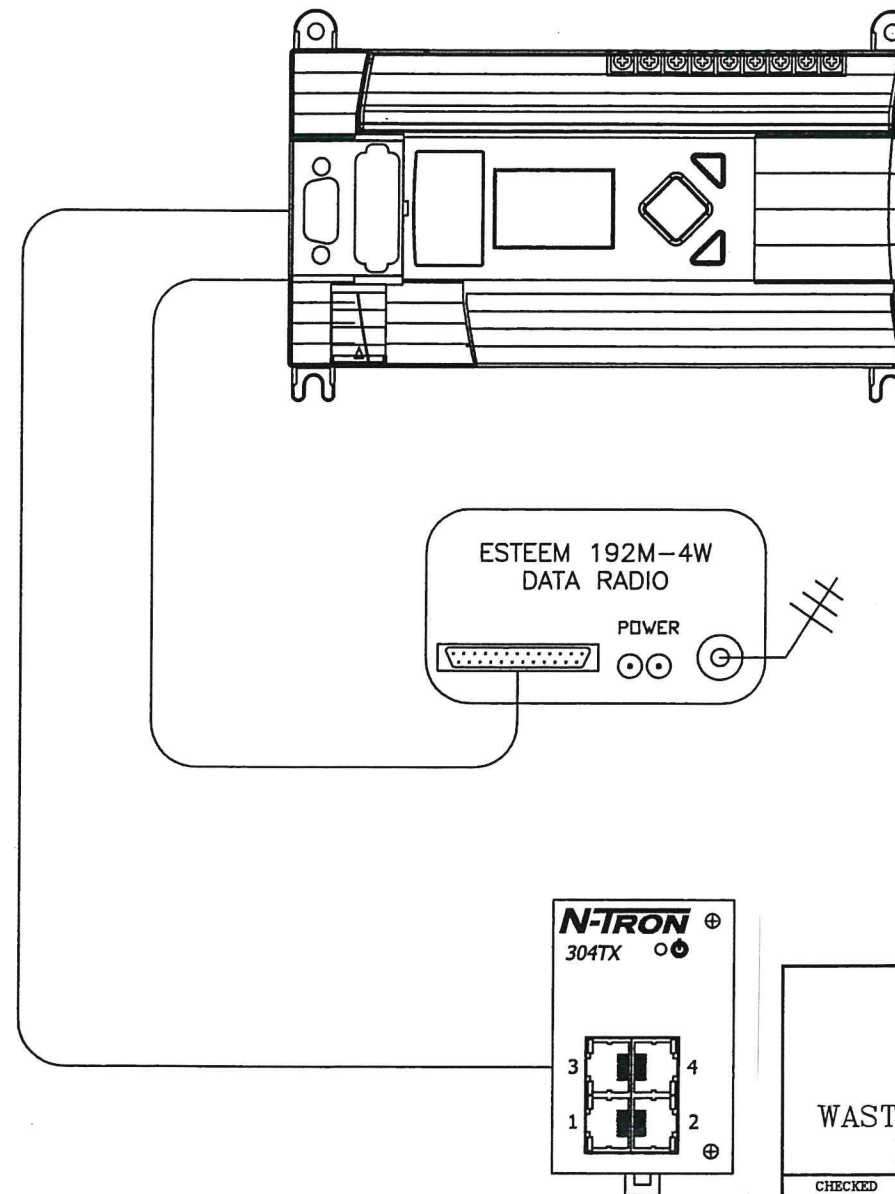

STANDARD DETAILS  
RTU CONTROL PANEL  
POWER WIRING  
TELEMETRY SYSTEM  
WASTEWATER PUMPING STATION  
MUNFORD, TENNESSEE

|                       |  |                     |
|-----------------------|--|---------------------|
| CHECKED<br>N/A        |  | SCALE<br>AS SHOWN   |
| LICENSE NO.<br>N/A    |  | SHEET NO.<br>4 OF 6 |
| DESIGNED<br>R. GAINES |  | DWG. NO.<br>4529    |
| DRAWN<br>R. GAINES    |  | DATE<br>05/24/2011  |
|                       |  |                     |

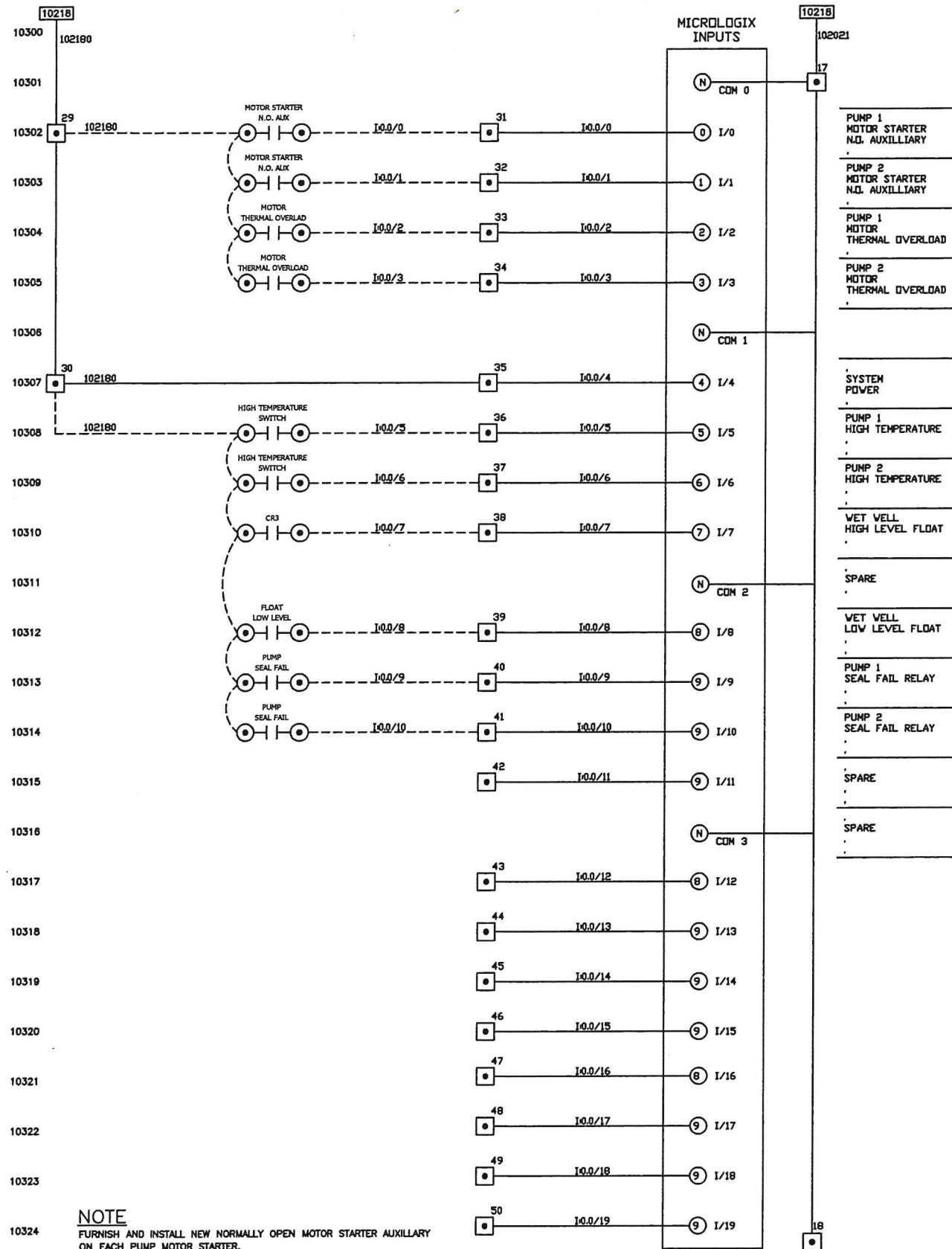

**NOTE**  
FURNISH AND INSTALL NEW NORMALLY OPEN MOTOR STARTER AUXILLARY ON EACH PUMP MOTOR STARTER.

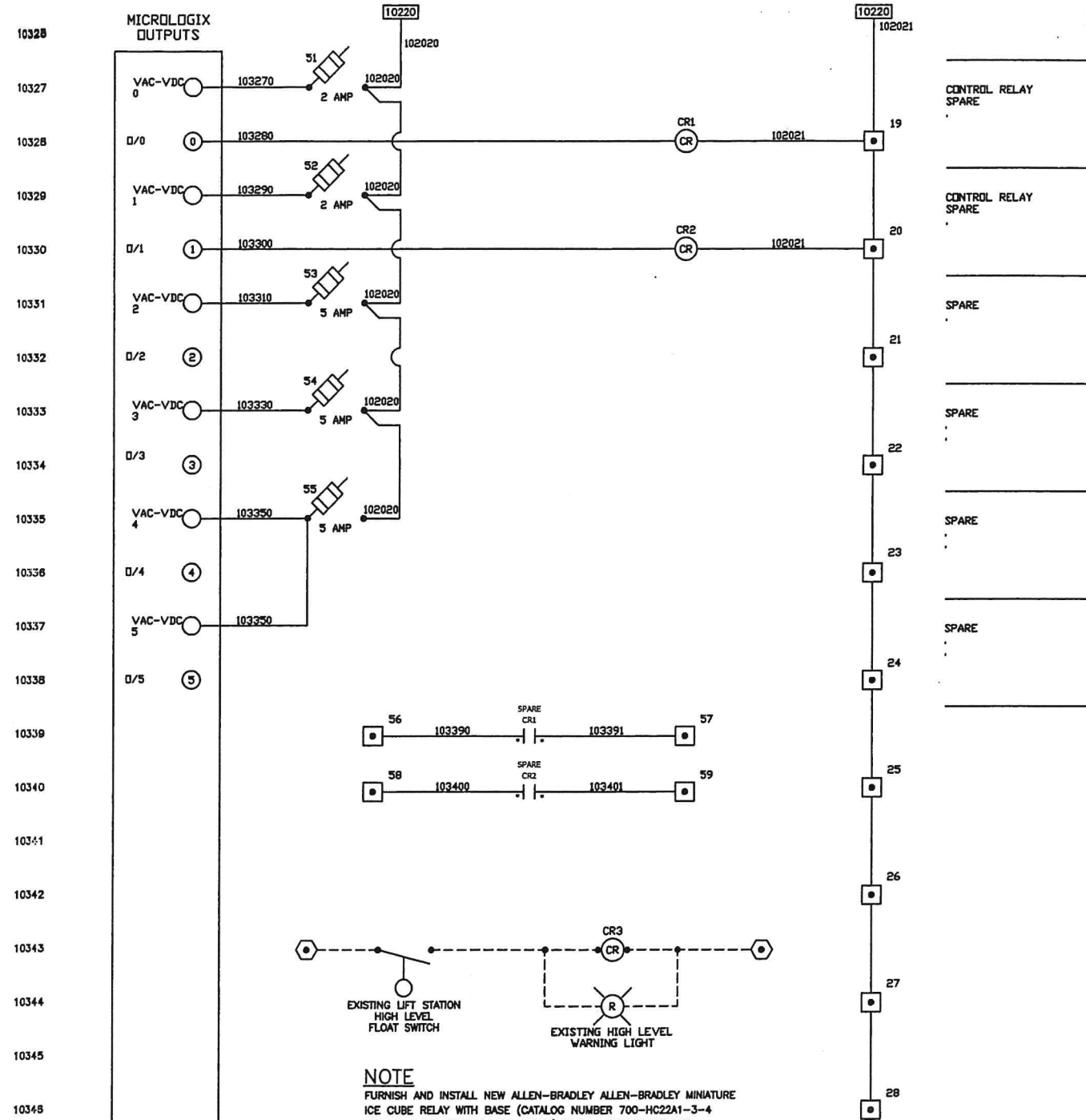

**NOTE**  
FURNISH AND INSTALL NEW ALLEN-BRADLEY ALLEN-BRADLEY MINIATURE ICE CUBE RELAY WITH BASE (CATALOG NUMBER 700-HC22A1-3-4 WITH CATALOG NUMBER 700-HN103) IN LIFT STATION CONTROL PANEL. DISCONNECT EXISTING HIGH LEVEL ALARM FLOAT SWITCH AND CONNECT TO NEW RELAY. CONNECT EXISTING FLOAT SWITCH LOAD WIRING TO RELAY CONTACTS, RELAY TERMINALS 9 AND 5 FOR NORMALLY OPEN OR 9 AND 1 FOR NORMALLY CLOSED.

**STANDARD DETAILS  
RTU CONTROL PANEL  
INPUT & OUTPUT WIRING  
TELEMETRY SYSTEM  
WASTEWATER PUMPING STATION  
MUNFORD, TENNESSEE**

|                       |   |                     |
|-----------------------|---|---------------------|
| CHECKED<br>N/A        | <br><b>KING ENGINEERING CONSULTANTS</b><br>Professional Engineers<br>Memphis, Tennessee | SCALE<br>AS SHOWN   |
| LICENSE NO.<br>N/A    |   | SHEET NO.<br>5 OF 6 |
| DESIGNED<br>R. GAINES |   | DWG. NO.<br>4520    |
| DRAWN<br>R. GAINES    |   | DATE<br>05/24/2011  |



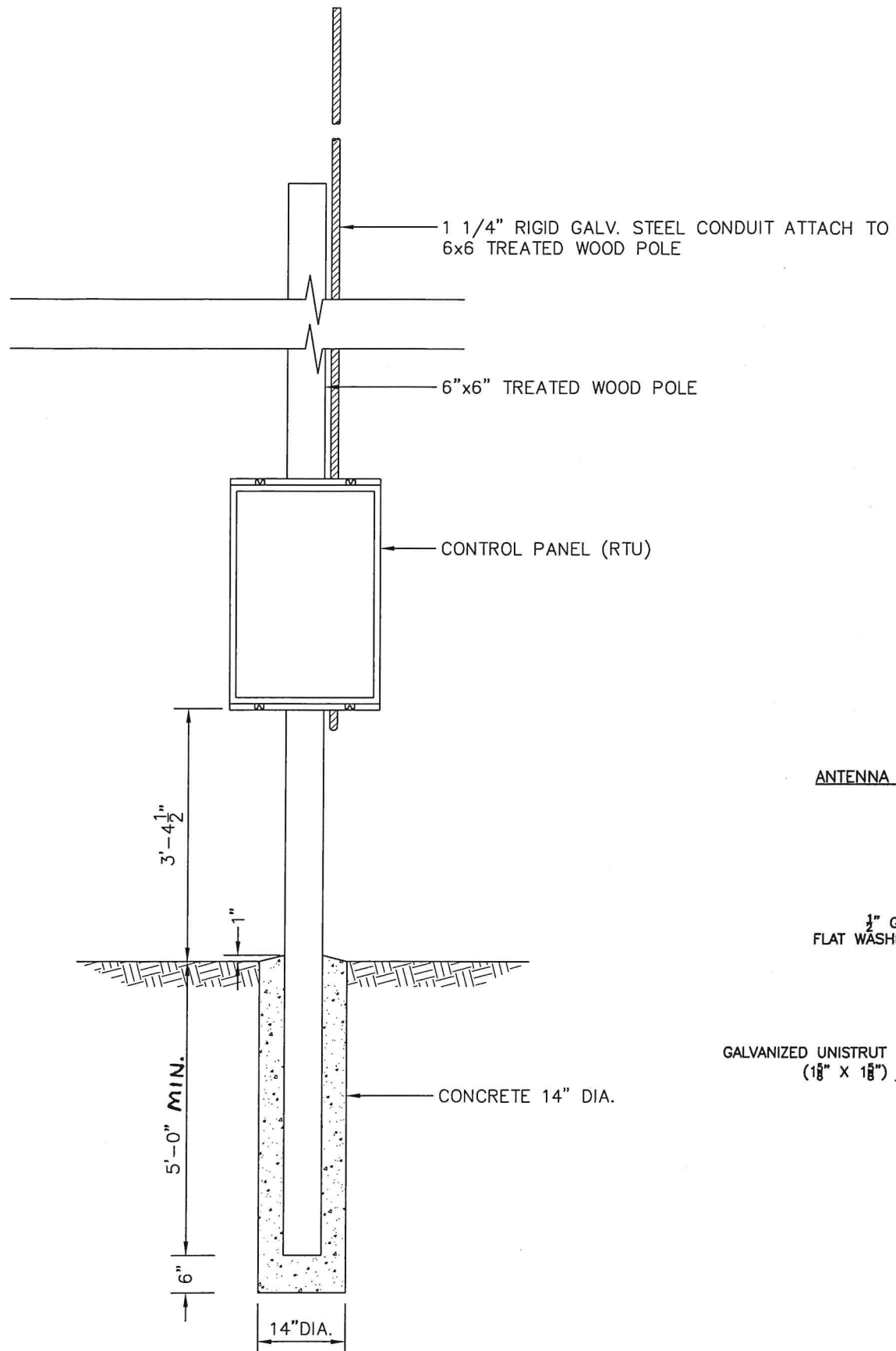

TYPICAL DETAIL  
TREATED WOOD POLE FOR ANTENNA AND  
CONTROL PANEL MOUNTING DETAIL

SCALE: NONE

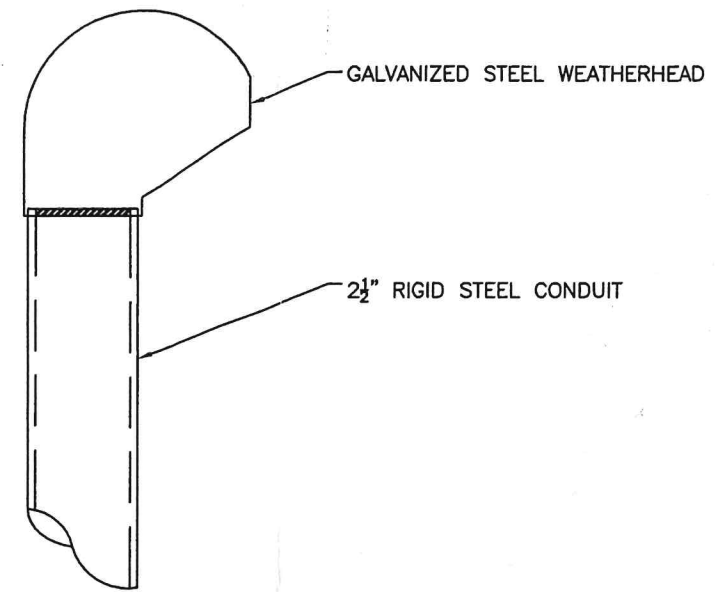

ANTENNA CONNECTION TO TOP OF MAST DETAIL

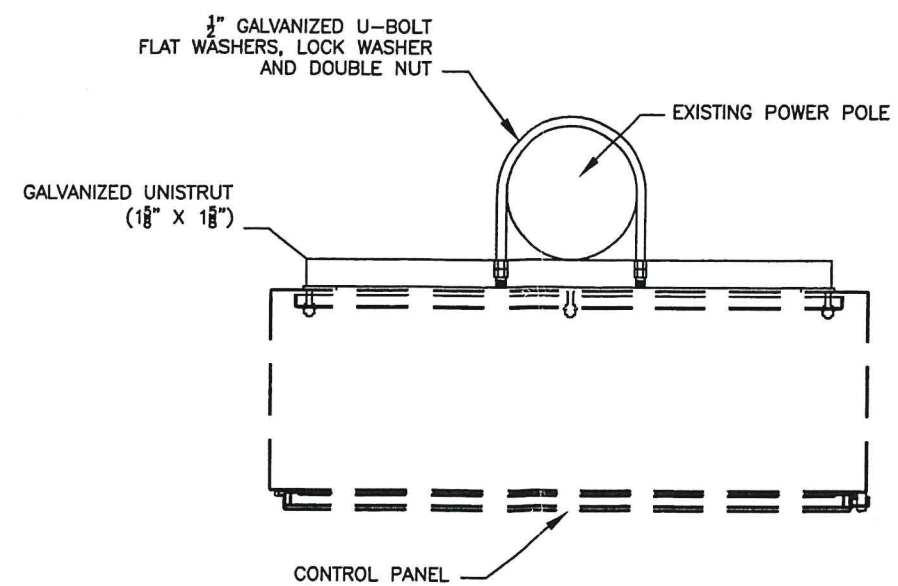

CONTROL PANEL MOUNTING DETAIL TOP PLAN

**GENERAL NOTES:**

1. STRUCTURAL PIPES SHALL BE ASTM A53, TYPE E, GRADE B, WITH YIELD STRENGTH = 35 KSI.
2. CHANNEL MEMBERS SHALL BE UNISTRUT P2000 OR EQUAL FABRICATED FROM STRUCTURAL GRADE STEEL CONFORMING TO ASTM A446, GRADE A.
3. ALL STEEL SHALL RECEIVE ONE COAT OF VALSPAR 13-R-28 CHROMOX SHOP PRIMER OR EQUAL FOLLOWED BY TWO COATS OF ALKYD ENAMEL PAINT.
4. CLOSE EXPOSED END OF PIPE MEMBERS WITH STEEL PLATE.
5. ALL WELDS SHALL BE MADE IN ACCORDANCE WITH LATEST PRACTICES OF A.W.S. USE E-70XX SERIES ELECTRODES.
6. CONCRETE SHALL HAVE MINIMUM COMPRESSIVE STRENGTH OF 3000 PSI AT 28 DAYS.

STANDARD DETAILS  
RTU MOUNTING DETAILS  
TELEMETRY SYSTEM  
WASTEWATER PUMPING STATION  
MUNFORD, TENNESSEE

|                       |  |                     |
|-----------------------|--|---------------------|
| CHECKED<br>N/A        |  <p>PROFESSIONAL ENGINEERS<br/>MEMPHIS, TENNESSEE</p> | SCALE<br>AS SHOWN   |
| LICENSE NO.<br>N/A    |  | SHEET NO.<br>6 OF 6 |
| DESIGNED<br>R. GAINES |  | DWG. NO.<br>4529    |
| DRAWN<br>R. GAINES    |  | DATE<br>05/24/2011  |
|                       |  |                     |