



**New City of New Buffalo
224 W. Buffalo Street
New Buffalo MI 49117
REGULAR COUNCIL MEETING AGENDA
July 19, 2021 6:30 PM**

1. Call to Order
2. Pledge of Allegiance
3. Roll Call
4. Approval of Agenda
5. Consent Agenda
 - a. City Council Minutes: June 22, 2021 (Rescheduled Meeting) July 7, 2021 (City Council Workshop)
 - b. Receive Monthly Reports: Police, Fire, Water, Park, Building, Streets, Code Enforcement and Treasurer
 - c. Monthly Account Payable
6. Public Comment
7. New Business
 - a. MDNR Waterways Grant Acceptance
 - b. USDA Rural Business Development Grant Acceptance
 - c. Donation Acceptance
 - d. 2021 Road Project Contract Award
 - e. Act 51 Street Administrator
 - f. City of New Buffalo Code of Ordinances Amendment – Chapter 9 (Second Reading)
 - g. City of New Buffalo Code of Ordinances Amendment – Chapter 15; Article II (Second Reading)
8. Council Comments
9. Adjournment

Call to Order at 6:30 p.m.

Roll Call. Present: Flanagan, New Buffalo, MI, Berrien County; Robertson, New Buffalo, MI, Berrien County; Lijewski, New Buffalo, MI, Berrien County; Mayor Humphrey, New Buffalo, MI, Berrien County, Lou O'Donnell, Saugatuck, MI, Allegan County.

Staff Present: City Manager, Darwin Watson; City Clerk, Amy Fidler; Parks Director, Kristen D'Amico; City Treasurer, Kate Vyskocil

Approval of Agenda: Motion by Lijewski, seconded by Robertson to approve the agenda:

Roll Call Vote:

AYES: O'Donnell, Robertson, Lijewski, Flanagan, Humphrey

NAYES:

ABSENT:

ABSTAINED:

Motion Carried, 5-0.

Approval of City Council Minutes of May 17, 2021 Regular Meeting; June 2, 2021 Special Meeting: Motion by Lijewski, seconded by Flanagan to approve the Council Minutes of May 17, 2021 Regular Meeting; June 2, 2021 Special Meeting:

Roll Call Vote:

AYES: Robertson, Lijewski, Flanagan, Humphrey

NAYES:

ABSENT:

ABSTAINED: O'Donnell

Motion Carried, 4-0.

Approval of Consent Agenda: Motion by Flanagan, seconded by Lijewski to approve the consent agenda:

Roll Call Vote:

AYES: Flanagan, O'Donnell, Lijewski, Robertson, Humphrey

NAYES:

ABSENT:

ABSTAINED:

Motion Carried, 5-0.

Public Comment:

Bill Lenga

Joann Moskovic

Dan Hatch

Jodi Grant

Martin Dzuris

New Business

Fiscal Year 2020-2021 Budget Amendments: Motion by Flanagan, seconded by O'Donnell to approve the Fiscal Year 2020-2021 Budget Amendment:

Roll Call Vote:

AYES: Lijewski, Robertson, Flanagan, O'Donnell, Humphrey

NAYES:

ABSENT:

ABSTAINED:

Motion Carried, 5-0.

Sale of Property to New Buffalo Area Schools:

Motion by O'Donnell, seconded by Lijewski to untable the sale of property to New Buffalo Area Schools:

Roll Call Vote:

AYES: Robertson, O'Donnell, Lijewski, Flanagan, Humphrey

NAYES:

ABSENT:

ABSTAINED:

Motion Carried, 5-0.

Motion by O'Donnell seconded by Robertson to deny the Sale of Property to New Buffalo Area Schools:

Roll Call Vote:

AYES: O'Donnell, Robertson, Flanagan

NAYES: Lijewski, Humphrey

ABSENT:

ABSTAINED:

Motion Carried, 3-2.

Establishment of Mobile Concession Vending Fee: Motion by Flanagan, seconded by Lijewski to approve the Establishment of Mobile Concession Vending Fee of \$2250.00:

Roll Call Vote:

AYES: Flanagan, Lijewski, Humphrey

NAYES: O'Donnell, Robertson

ABSENT:

ABSTAINED:

Motion Carried, 3-2.

Outpost Sports Concession Agreement: Motion by Lijewski, seconded by O'Donnell to approve the Outpost Sports Concession Agreement for the next two years:

Roll Call Vote:

AYES: Robertson, Lijewski, Flanagan, O'Donnell, Humphrey

NAYES:

ABSENT:

ABSTAINED:

Motion Carried, 5-0.

Special Use Permit Approval – 1 N. Whittaker: Motion by Flanagan, seconded by Lijewski to approve the Special Use Permit Approval for outside seating – 1 N. Whittaker:

Roll Call Vote:

AYES: Lijewski, Robertson, O'Donnell, Flanagan, Humphrey

NAYES:

ABSENT:

ABSTAINED:

Motion Carried, 5-0.

Downtown Development Authority Appointment: Motion by O'Donnell, seconded by Robertson to approve the Downtown Development Authority Appointment of J.V. Peacock:

Roll Call Vote:

AYES: Flanagan, O'Donnell, Robertson, Lijewski, Humphrey

NAYES:

ABSENT:

ABSTAINED:

Motion Carried, 5-0.

Marina Repairs Pay Request (Mead & White): Motion by Robertson, seconded by Flanagan to approve the Marina Repair Pay Requests (Mead & White) in the amount of \$11,971.50:

Roll Call Vote:

AYES: O'Donnell, Robertson, Lijewski, Flanagan, Humphrey

NAYES:

ABSENT:

ABSTAINED:

Motion Carried, 5-0.

Property Leasing from New Buffalo Development Partners, LLC: Motion by Humphrey, seconded by Lijewski to approve the Property Leasing agreement from New Buffalo Development Partners, LLC:

Roll Call Vote:

AYES: Lijewski, Robertson, O'Donnell, Flanagan, Humphrey

NAYES:

ABSENT:

ABSTAINED:

Motion Carried, 5-0.

Traffic Control Order Resolution: Motion by Robertson, seconded by Lijewski to approve the Traffic Control Order Resolution:

Roll Call Vote:

AYES: Flanagan, O'Donnell, Robertson, Lijewski, Humphrey

NAYES:

ABSENT:

ABSTAINED:

Motion Carried, 5-0.

Veteran and Senior Citizen Discount (Boat Launch Pass): Motion by Robertson, seconded by O'Donnell to approve a 50% off Veteran and Senior Citizen Discount (Boat Launch Pass):

Roll Call Vote:

AYES: Robertson, Lijewski, Flanagan, O'Donnell, Humphrey

NAYES:

ABSENT:

ABSTAINED:

Motion Carried, 5-0.

City of New Buffalo Code of Ordinances Amendment – Chapter 9 (First Reading): Motion by Robertson, seconded by Lijewski to approve City of New Buffalo Code of Ordinances Amendment – Chapter 9 (First Reading):

Roll Call Vote:

AYES: O'Donnell, Robertson, Lijewski, Flanagan, Humphrey

NAYES:

ABSENT:

ABSTAINED:

Motion Carried, 5-0.

City of New Buffalo Code of Ordinances Amendment – Chapter 15; Article II (First Reading): Motion by Robertson, seconded by Flanagan to approve City of New Buffalo Code of Ordinances Amendment – Chapter 15; Article II (First Reading):

Roll Call Vote:

AYES: Flanagan, O'Donnell, Robertson, Lijewski, Humphrey

NAYES:

ABSENT:

ABSTAINED:

Motion Carried, 5-0.

Discussion:

Dates for City Council Workshop:

City Manager Watson, explained that he would like to have a workshop where all of the council members could bring up topics that they would like to discuss.

The council decided to get all of their topics and comments to City Manager Watson by Friday, July 2, 2021. The workshop will be a public meeting at 5:30 p.m. on Wednesday, July 7, 2021.

Council Comments: Councilmember Flanagan did not bring the Pokagon Fund Report. He will bring it to the next Council Meeting.

Mayor Humphrey wanted to acknowledge the passing of former City Councilmember, Elizabeth Ennis. There was a moment of silence in honor of Ms. Ennis.

Adjournment:

Motion by Flanagan, seconded by Robertson to adjourn the meeting at 8:07 p.m.

Roll Call Vote:

AYES: Robertson, Lijewski, Flanagan, O'Donnell, Humphrey

NAYES:

ABSENT:

ABSTAIN:

Motion Carried, 5-0.

af

John Humphrey, Mayor

Amy Fidler, Clerk

Call to Order at 5:30 p.m.

Pledge of Allegiance led by the City Council.

Roll Call. Members Present: Councilmembers, Brian Flanagan, Lou O'Donnell, Mark Robertson, Roger Lijewski, Mayor John Humphrey

Staff Present: City Manager, Darwin Watson; City Clerk, Amy Fidler; City Treasurer, Kate Vyskocil; Deputy Clerk, Nancy Griffin

Approval of Agenda: Motion by Flanagan, seconded by Lijewski to approve the agenda. Voice vote unanimous. Motion carried.

Public Comment:

Debbie Schmidt
Laura Murray
Edan Gelt
Karen Doughty
Jamie Pachciarz
Ryan Nofziger
Bill Carroll
Chris Yonker
Mary Rose Denton

Presentation-City Treasurer, Kate Vyskocil.

Overview of grant projects.

Council expressed their feelings on which projects they would like prioritized for completion.

Adjournment:

Motion by Flanagan, seconded by Lijewski to adjourn the meeting at 6:53 p.m. Voice vote unanimous. Motion carried.

af

John Humphrey, Mayor

Amy Fidler, Clerk



Mr. Watson,

It is my pleasure to report some of the highlights from the last month of the Police Department's operations. If you would like additional information on any of these items, please let me know.

- In the last 30 days, the NBPD has taken 110 complaints. Those include 5 accidents, 2 traffic arrests, 5 assaults, and 9 ordinance related incidents.
- One incident of interest involved a house fire on Locke Rd In Chikaming Township. Sgt Tillery and Officer Voytovick responded to assist Chikaming Township Fire on a structure fire with a subject still inside. Sgt Tillery arrived first and went into the smoke-filled home and was able to get the homeowner out of the home. That subject was taken to Bronson Hospital with severe second- and third-degree burns.
- For the summer, we have expanded our hours for our downtown/beach patrol to provide better coverage on the evenings. You will see Officer Gallagher and Officer Severn covering this later shift.

Sincerely,

Rich Killips

Richard L Killips

Chief of Police



MEMORANDUM

To: City Manager, Mayor & Council Members

From: Fire Chief Chris Huston

Date: July 15, 2021

Last month the Fire Department held a training meeting on June 17, 2021 and business meeting on July 17, 2021. The Department had a total of 11 fire calls.

July 5, 2021



MONTHLY WATER REPORT FOR JUNE 2021

Total amount of water treated in month	21,500,000 gals
Average daily pumpage in month	717,000 gals.
Maximum treated for one day	838,000 gals.
Minimum treated for one day	599,000 gals.
Backwash water used in month	369,000 gals.

COMPARISON BY MONTH AND YEAR

June	2021 (this year) consumption	21,500,000 gals.
June	2020 (last year) consumption	21,024,000 gals.

CHEMICAL COSTS AND DATA

Chlorine used in month: 527 lbs. @1.1250 /lb.	\$ 592.88
Fluoride used in month: 707 lbs. @ 0.4867 / lb.	\$ 344.10
Aluminum sulfate used in month:7,042 lbs @ \$0.1615 lb.	\$ 1,137.28
Total amount spent on chemicals	\$ 2,074.26
Total amount per million gallons	\$ 96.48

MAINTENANCE REPORT

1. Exercised generators and checked cathodic protection systems.
2. Cut grass @ Water Treatment Plant.
3. Moved storage container from R.R. Museum to Water Plant for winter storage - deep snow conditions. Josh and boys did a great job moving things around and bring area to proper grade.
4. Runkle Electric worked on trouble shooting High Service #3 VFD and installed rebuilt unit and worked on start up and programming with Kendall Electric.

DISTRIBUTION REPORT

1. Made new 1" water tap & set 1" meter pit assembly 22 Preserve.
2. Read water meters.
3. Did staking for Miss Dig Systems.
4. Did ons/offers and checked high reading complaints.
5. Did bacteriologic testing for neighboring communities.
6. Repaired valve box @ Dunewood Subdivision during month.
7. Flow tested fire hydrant for new upcoming school project.

8. Repaired damaged fire hydrant SE. corner E. Water & N. Townend St.
9. Rob cleaned up brass on old water meters and delivered to salvage yard in Laporte , Indiana.
- 10.. Rob had CDL physical during month.
11. Did pressure test for low flow complaint during month.
12. Replaced meter pit assembly @ 425 & 427 South Whittaker Street.
13. Assembled new 2" meter assembly @ 116 N. Whittaker Street and plumbers installed during month.

FUEL REPORT

1. Gasoline consumed	107.1 gals.
2. Diesel fuel consumed	20.0 gals.
3. Total fuel consumed	127.1 gals.
4. Average per day	4.2 gals.

EQUIPMENT USAGE

Water Department backhoe	20.0 hrs.
Street Department backhoe	0.0 hrs.
Water Department Dump Truck	0.0 hrs.
Other	20.0 hrs.

BENEFIT MAN HOURS USED DURING MONTH

*	<u>vacation</u>	<u>personal</u>	<u>sick</u>	<u>total hrs.</u>
Ken Anderson	48.0 T.M. 88.0 YTD	0.0 T.M. 27.0 YTD	0.0 T.M. 16.0 YTD	48.0 T.M. 131.0 YTD
Chris Huston	8.0 T.M. 40.0 YTD	0.0 T.M. 0.0 YTD	8.0 T.M. 40.5 YTD	16.0 T.M. 80.5 YTD
Robert Gruener	24.0 T.M. 76.0 YTD	1.0 T.M. 12.0 YTD	0.0 T.M. 16.0 YTD	25.0 T.M. 104.0 YTD
Jeff Johnson	8.0 T.M. 48.0 YTD	0.0 T.M. 8.0 YTD	0.0 T.M. 11.75 YTD	8.0 T.M. 67.75 YTD

* (T.M. = This Month YTD = Year-to-date)

Proposed Work For Month of July 2021

1. Installing new meter pit assemblies.
2. Continuing COVID-19 Governor Mandates.
3. Begin Collecting voluntary Cyanotoxin sampling for EGLE.
4. Starting to collect EGLE Compliance Lead And Copper Samples.

Respectfully submitted,



Kenneth A. Anderson
City of New Buffalo
Water Superintendent



July 15, 2021

To: Mayor and City Council

Summer is in full swing, and the beach, marina and boat launch have all been very busy so far.

The beach has been seeing a record number of visitors so far this season. Because of the increased traffic as well as the price increases our revenue is up significant from last season. Our current revenue at the beach and boat ramp from 4/1-7/8 is \$124,897 up from last years \$102,217!

The concession stand seems to be doing well. Dan is doing his very best to serve our visitors. He recently added beach chair and umbrella rentals. These will be rented out for visitors to use instead of lugging all their own down to the beach.

Third Coast is also doing very well! From talking to Ryan, they are once again show record sales! So far the new parking configuration seems to be working out well. I have also told them they can use part of the grass next to the kayak parking as well as part of the employee parking area. They have such a great business, that I hate to see them loose customers over parking.

The marina repairs are complete, and the reactions from the boaters has been very positive to all the changes being made. Audrey is doing a fantastic job, and the boaters really appreciate how things are running. We did however have some recent vandalism at the marina on June 29th. Vandals kicked over 2 power pedestals and destroyed them. Replacements have been ordered and are expected to arrive within the next week. Unfortunately, these being down makes it a challenge for reservations. Four slips are without power, but Audrey had been doing her best to accommodate everyone.

Baseball season has come to a close. We worked very hard this summer to keep the fields in good playing condition. My assistant Kelsee did an amazing job maintaining the fields. I have spoken to Hoestetler and he will be out this month to look at the fields. I am planning on having new ball mix for field 1, and new ball mixes and new bases for fields 2 & 4.

All in all, I'd say this summer has been going much smoother than last and everyone seems to been in a much better state of mind.

Respectfully submitted,

Kristen D'Amico
Parks Director

Monthly Permit List

07/09/2021

Building

Permit #	Contractor	Job Address	Fee Total	Const. Value
PB21-0068	Wlodarczyk Wieslaw & Janina	25 S Norton St	\$420.00	\$0
Work Description: ReRoof existing house ReSide existing hoouse				
PB21-0072	North Whittaker LLC	116 Whittaker N	\$315.00	\$0
Work Description: Repairs to existing building due to water and rot damage				
PB21-0073	Adams Carol L Trust	601 Lake DR	\$630.00	\$0
Work Description: 11x5 Bathroom addition				
PB21-0076	Ciardelli III Victor F	130 Eagle N	\$315.00	\$0
Work Description: 308 sq ft detached garage.				
PB21-0078	Zeleneva Zhanna	16 N Barker St	\$210.00	\$0
Work Description: New Pergola				
PB21-0081	North Whittaker LLC	116 Whittaker N	\$210.00	\$0
Work Description: New signs for Starbucks				
PB21-0071	MESSAGLIA, MARK & LISA	800 Mechanic ST	\$315.00	\$0
Work Description: Re-Siding House				
PB21-0075	EVANGELICAL, CHURCH	200 Buffalo W	\$315.00	\$0
Work Description: Remove and replace existing roofing system				
PB21-0079	Friend Steven J & Loretta R	126 N Barker ST	\$315.00	\$0
Work Description: Roofing new detached garage				
PB21-0070	Donegan Daniel J Trust	108 S Kenzie Street	\$315.00	\$0
Work Description: Water Damage Repairs				
PB21-0074	Big Brother Real Estate Holdings	36 S Whittaker ST	\$315.00	\$0
Work Description: Concrete Sona-tubes foundation for future tanks if approved by planning commission				
PB21-0069	1 North Whittaker LLC	1 N Whitaker ST	\$315.00	\$0
Work Description: Foundation/Basement Water Proofing and drainage.				
PB21-0077	Myers Barbara B Trust	33 N Willard St	\$971.25	\$0
Work Description: New Single Family Home on Vacant Lot				
PB21-0080	Vlomis Neena L Living Trust	120 W Buffalo ST	\$3,816.75	\$0
Work Description: New Office Building				

Total Permits For Type:	14
Total Fees For Type:	\$8,778.00
Total Const. Value For Type:	\$0

Electrical

Permit #	Contractor	Job Address	Fee Total	Const. Value
PE21-0035	NEW BUFFALO, CITY OF CITY I	850 E Buffalo W	\$332.85	\$0
Work Description:				
PE21-0033	Donofrio David J & Mary	323 S Norton	\$520.80	\$0
Work Description: Electrical for New Single Family Home				
PE21-0043	North Whittaker LLC	116 Whittaker N	\$199.50	\$0
Work Description: New Starbucks Signs				
PE21-0034	Parpat LLC	805 W Water ST	\$256.50	\$0
Work Description: Alterations				
PE21-0042	Whitehead Pamela J	309 Willard S	\$248.85	\$0
Work Description: Electrical for new Pool				
PE21-0041	WORMUTH, WILLIAM & GAYLE	1136 Shore DR	\$285.60	\$0
Work Description: Electrical alterations to existing house.				
PE21-0038	Friend Steven J & Loretta R	126 N Barker ST	\$415.80	\$0
Work Description: Electrical work of accessory building				
PE21-0037	Berk Jingming Li	318 S Marshall ST	\$246.75	\$0
Work Description: Service				
PE21-0036	GATZ, DAVID & WILLIAMS, DIA	326 S Chicago ST	\$168.00	\$0
Work Description: Service Only				
PE21-0039	Sucich Linda	127 S Thompson ST	\$264.60	\$0
Work Description:				
PE21-0040	North Whittaker LLC	116 Whittaker N	\$430.50	\$0
Work Description: Electrical work for Accessory Building				

Total Permits For Type:	11
Total Fees For Type:	\$3,369.75
Total Const. Value For Type:	\$0

Mechanical

Permit #	Contractor	Job Address	Fee Total	Const. Value
PM21-0053	Friend Steven J & Loretta R	126 N Barker ST	\$472.50	\$0
Work Description: Detached Garage				
PM21-0051	MAJKA, JOHN & JOELLEN TRUS	419 W Washington ST	\$189.00	\$0
Work Description: Heat Pump				
PM21-0052	O'Brien James M & Joan D Trust	1321 Shore DR	\$189.00	\$0
Work Description: A/C				
PM21-0050	Back to Work LLC	630 S Jameson ST	\$220.50	\$0
Work Description: Furnace and A/C replacement				
PM21-0049	Williams Scott B	115 S Clinton ST	\$220.50	\$0
Work Description: Furnace and A/C replacement				
PM21-0054	GONZALES, LUIS & JANICE A T	115 S Marshall ST	\$189.00	\$0
Work Description: A/C Replacement				

Total Permits For Type: 6
Total Fees For Type: \$1,480.50
Total Const. Value For Type: \$0

Plumbing

Permit #	Contractor	Job Address	Fee Total	Const. Value
PP21-0034	Three Blind Mice Properties LLC	427 Whittaker S	\$252.00	\$0
Work Description: Splitting Water Line to Rear Garage and Sewer line also				
PP21-0010	Friend Steven J & Loretta R	126 N Barker ST	\$396.90	\$0
Work Description: Plumbing Alterations				
PP21-0032	North Whittaker LLC	116 N Whittaker Apt B	\$375.90	\$0
Work Description: Plumbing alterations to existing Building				
PP21-0033	Dyer Deborah H	121 S Franklin ST	\$452.55	\$0
Work Description: Alterations				
PP21-0031	GATZ, DAVID & WILLIAMS, DIA	326 S Chicago ST	\$416.85	\$0
Work Description: New Single Family Home				
PP21-0035	Sucich Linda	127 S Thompson ST	\$173.25	\$0
Work Description: Fixture, Drain, water line.				

Total Permits For Type: 6

Total Fees For Type: \$2,067.45
Total Const. Value For Type: \$0

Zoning

Permit #	Contractor	Job Address	Fee Total	Const. Value
PZ21-0002	BUFFALO TRADING, LLC	1 N Whitaker ST	\$350.00	\$0
Work Description: Site Plan Application				

Total Permits For Type: 1
Total Fees For Type: \$350.00
Total Const. Value For Type: \$0

Report Summary

Population: All Records
Permit.DateIssued Between
6/1/2021 12:00:00 AM AND
6/30/2021 11:59:59 PM

Grand Total Fees: \$16,045.70
Grand Total Permits: 38
Grand Total Const. Value: \$0



Street Department Monthly Report
June 2021

Mayor Humphrey and City Council Members,

The fluctuating weather temperatures and rain dictate what the street department can accomplish along with unforeseen situations that may arise. The following are some of many things we have accomplished during the month of June.

- ✓ Continuing to address roads with cold patch repairs, cleaning curb and gutters in needed areas, picking up brush and debris from previous weather changes and storms, cleaning storm drains to maintain sufficient flow for storm waste water and clearing for right-of-way visibility safety.
- ✓ Streets crew has started mowing and weed eating at multiple right-of-way's, edging sidewalks in the downtown area and welcome signs.
- ✓ Marked storm drains per Miss Dig request throughout the city for multiple contractors.
- ✓ The City garage has serviced equipment form all park mowers and weed eaters, police vehicles and side by side, beach equipment life guard ATV and streets backhoe, dynapac roller, and other small equipment all requiring time for parts to be ordered from all different suppliers and time spent in the shop to make the repairs.
- ✓ Regarded and added stone to damaged gravel roads.

Respectfully Submitted,

A handwritten signature in blue ink, appearing to read "Josh Bolton", is written over a light blue rectangular background.

Josh Bolton
Crew Leader



7/15/2021

Dear City Manager Watson,

RE Code Enforcement Monthly Department Update:

Although this is not an all-inclusive list, please see the following items attended to over this past month.

- Short Term Ordinance number #248 became effective June 14th, 2021. We are working to update our forms and letters to meet the terms of the new ordinance. We have started a Courtesy Letter format to advise STR Permit holders the impending expiration of their permit. Parties are to have applications, inspections and any fees paid prior to the expiration. We have established deadlines in our standards and practices.
- Grass notification letters have been issued.
- Our new Parking Officer is monitoring 3 Hour and City Beach Lot parking, as well as clearing the roads for Farmer's Market set up. We many want to evaluate the time allowed for set up in future seasons. Parties are still submitting Resident Beach Pass Applications. We have processed over 100 Citation appeals.
- The STR Permits being issued at this time are renewals and new owners (where there was an existing permit). I have done an audit and we are following up on a couple of permits, questioning PRE status. This information will be forwarded to Assessing.
- We have worked with the PD to provide the correct contact information and establish the 24-Hour hotline with Granicus and the applicable guidelines.
- A substantial amount of time is spent making and returning phone calls. Much of this is parties looking for explanations regarding the new STR Ordinance and the Moratorium.
- We are awaiting the revised Trash Ordinance for enforcement.

Thank you! Respectfully, Gail Grosse
CODE ENFORCEMENT OFFICER

Meeting, Ordinance, and Zoning Information available: www.cityofnewbuffalo.org



To: Mayor Humphrey and Council
Re: Treasurer's Monthly Report
Date: July 15, 2021

Please find attached the following items for your review:

- A. Summary of Payables as of today.
- B. Statements from:
 - Abonmarche
 - The Curcio Law Firm
- C. Invoice Approval List by Fund
- D. Revenue/Expenditure Report

Please do not hesitate to contact me should you have questions or need additional information.

Kind regards,

Kate Vyskocil

Kate Vyskocil, MBA, MiCPT
Treasurer

BANK CODE: POOL CHECK DATE: 07/13/2021 INVOICE PAY DATE FROM 07/13/2021 TO 07/13/2021

Check Date	Bank	Check #	Vendor Code	Vendor Name	Amount	# Invoices
07/13/2021	POOL	00000041630	2862	ABONMARCHE CONSULTANTS INC	4,840.50	2
07/13/2021	POOL	00000041631	1001	ADAMS REMCO INC	363.51	1
07/13/2021	POOL	00000041632	4984	ALEX SMEYERS	384.02	1
07/13/2021	POOL	00000041633	1004	ALEXANDER CHEMICAL CORP	5,106.28	3
07/13/2021	POOL	00000041634	3490	AMERICAN SAFETY & FIRST AID	60.68	1
07/13/2021	POOL	00000041635	4501	AMY FIDLER	229.40	1
07/13/2021	POOL	00000041636	2038	ANDERSON, KENNETH	50.00	1
07/13/2021	POOL	00000041637	4971	APPOLO FIRE EQUIPMENT	146.05	1
07/13/2021	POOL	00000041638	4817	B AND Z COMPANY	2,357.50	1
07/13/2021	POOL	00000041639	4515	BLOSSOMLAND ACCOUTNING	906.25	1
07/13/2021	POOL	00000041640	4042	BLUE CROSS BLUE SHIELD OF MICH	2,842.31	1
07/13/2021	POOL	00000041641	4042	BLUE CROSS BLUE SHIELD OF MICH	24,212.27	1
07/13/2021	POOL	00000041642	4298	BOLTON, JOSHUA	50.00	1
07/13/2021	POOL	00000041643	3848	BREATHING AIR SYSTEMS	504.75	1
07/13/2021	POOL	00000041644	4534	CDW GOVERNMENT	3,009.59	3
07/13/2021	POOL	00000041645	4712	CHARLES NICHOLAS CURCIO	831.00	1
07/13/2021	POOL	00000041646	3469	CLUSTER, MICHAEL	147.67	2
07/13/2021	POOL	00000041647	4661	COUNTRY LANE REMODELING/MIKE PLIS	130.00	1
07/13/2021	POOL	00000041648	4462	D'AMICO KRISTEN	50.00	1
07/13/2021	POOL	00000041649	1150	DARLEY & CO, WS	2,976.30	2
07/13/2021	POOL	00000041650	4782	DOMESTIC UNIFORM RENTALS	1,057.06	12
07/13/2021	POOL	00000041651	4758	E.I. CONSTRUCTION	1,165.00	1
07/13/2021	POOL	00000041652	4779	EMERGENCY VEHICLES PLUS	1,664.14	1
07/13/2021	POOL	00000041653	1047	ETNA SUPPLY COMPANY	2,622.17	4
07/13/2021	POOL	00000041654	2061	FRONTIER LAWN & REC INC	42.45	1
07/13/2021	POOL	00000041655	4985	GLASDON INC	482.50	1
07/13/2021	POOL	00000041656	4781	GRIFFIN, NANCY	239.89	1
07/13/2021	POOL	00000041657	4767	GROSSE, GAIL	7.42	1
07/13/2021	POOL	00000041658	1058	GRSD SEWER AUTHORITY	289.04	1
07/13/2021	POOL	00000041659	3529	GRUENER, ROBERT	50.00	1
07/13/2021	POOL	00000041660	MISC	GRZYBOWSKI, SCOTT	25.00	1
07/13/2021	POOL	00000041661	1059	HACH COMPANY	995.87	2
07/13/2021	POOL	00000041662	2089	HEI WIRELESS	480.00	1
07/13/2021	POOL	00000041663	3678	HUSTON, CHRISTOPHER	50.00	1
07/13/2021	POOL	00000041664	2963	IDEXX DISTRIBUTION CORP	787.55	1
07/13/2021	POOL	00000041665	4173	INTEGRA CERT. DOCUMENT DESTRUCTION	52.74	1
07/13/2021	POOL	00000041666	4693	J. P. GILLEN & ASSOCIATES/EDGE IT	3,425.00	1
07/13/2021	POOL	00000041667	3531	JOHNSON, JEFFREY	50.00	1
07/13/2021	POOL	00000041668	4479	KASSOBOHRER ALL TERRAIN VEHICLES IN	50,500.00	1
07/13/2021	POOL	00000041669	4610	KENDALL ELECTRIC	7,663.06	3
07/13/2021	POOL	00000041670	3661	KENNETH L KORP	400.00	1
07/13/2021	POOL	00000041671	4639	KIESLER POLICE SUPPLY	388.10	1
07/13/2021	POOL	00000041672	2944	LAKELAND HEALTHCARE	196.00	1
07/13/2021	POOL	00000041673	4206	LAKESHORE RECYCLING & DISPOSAL LLC	22,147.28	2
07/13/2021	POOL	00000041674	3382	MEDIC 1	9,283.42	1
07/13/2021	POOL	00000041675	3524	MENARDS	188.98	3
07/13/2021	POOL	00000041676	3995	MICHIGAN RURAL WATER ASSOC	145.00	1
07/13/2021	POOL	00000041677	4062	MICHIGAN STATE POLICE	259.50	2
07/13/2021	POOL	00000041678	2072	MMTA	359.00	1
07/13/2021	POOL	00000041679	1085	MODEL COVERALL	120.00	1
07/13/2021	POOL	00000041680	4957	MTECH	696.32	1
07/13/2021	POOL	00000041681	1113	NEW BUFFALO AREA SCHOOLS	2,374.20	1
07/13/2021	POOL	00000041682	4498	NEW BUFFALO HARDWARE	209.01	11
07/13/2021	POOL	00000041683	2032	NEW BUFFALO TOWNSHIP	56.99	1
07/13/2021	POOL	00000041684	4550	OCCUSCREEN, LLC	70.00	1
07/13/2021	POOL	00000041685	1153	OSELKA MARINA	138.86	1
07/13/2021	POOL	00000041686	3800	PARAGON LABORATORIES INC	184.00	1
07/13/2021	POOL	00000041687	1100	PARRETT COMPANY	101.72	1

CHECK PROOF

Page: 2/2

BANK CODE: POOL CHECK DATE: 07/13/2021 INVOICE PAY DATE FROM 07/13/2021 TO 07/13/2021

Check Date	Bank	Check #	Vendor Code	Vendor Name	Amount	# Invoices
07/13/2021	POOL	00000041688	2085	PINE GROVE CEMETERY AUTHORITY	2,500.00	1
07/13/2021	POOL	00000041689	3126	PITNEY BOWES INC	180.00	1
07/13/2021	POOL	00000041690	4625	PRECISION CARTRIDGE CO	1,180.00	1
07/13/2021	POOL	00000041691	4684	PRIDE THE PORTABLE TOILET COMPANY	1,160.00	4
07/13/2021	POOL	00000041692	2065	RIDGE AUTO PARTS	545.50	7
07/13/2021	POOL	00000041693	3501	RUNKLE ELECTRIC	625.00	1
07/13/2021	POOL	00000041694	4703	SAFEBUILT LLC	11,924.93	1
07/13/2021	POOL	00000041695	4801	SANISWEEP, INC	1,050.00	1
07/13/2021	POOL	00000041696	4130	SCHULTZ, FRED	161.45	1
07/13/2021	POOL	00000041697	2374	SEIFERT'S FARM SUPPLY	106.00	1
07/13/2021	POOL	00000041698	3199	SITTIG ASSESSMENT SERVICES LLC	4,285.00	2
07/13/2021	POOL	00000041699	3156	STAPLES	111.97	1
07/13/2021	POOL	00000041700	4186	STAR UNIFORMS	2,546.18	10
07/13/2021	POOL	00000041701	3497	STATE OF MICHIGAN DEQ	720.00	1
07/13/2021	POOL	00000041702	2467	TELE-RAD INC	343.80	1
07/13/2021	POOL	00000041703	2844	THREE OAKS FORD	194.88	2
07/13/2021	POOL	00000041704	4018	TOTAL PARKING SOLUTIONS	4,920.00	2
07/13/2021	POOL	00000041705	4453	TRUGREEN PROCESSING CENTER	437.00	2
07/13/2021	POOL	00000041706	4698	US BANK EQUIPMENT FINANCE	239.68	1
07/13/2021	POOL	00000041707	2969	USA BLUEBOOK	427.17	1
07/13/2021	POOL	00000041708	3922	VERIZON WIRELESS	736.33	1
07/13/2021	POOL	00000041709	4350	VERSAW EARTHWORKS LLC	1,157.50	1
07/13/2021	POOL	00000041710	4487	VYSKOCIL, KATHRYN	50.00	1
07/13/2021	POOL	00000041711	3614	WORKING WELL	110.00	1

Num Checks: 82

Num Stubs: 0

Num Invoices: 142

Total Amount: 193,877.74

ABONMARCHE

Engineering • Architecture • Land Surveying

CITY OF NEW BUFFALO

Attn: Rich Killips
 City Hall
 224 W. Buffalo Street
 New Buffalo, MI 49117

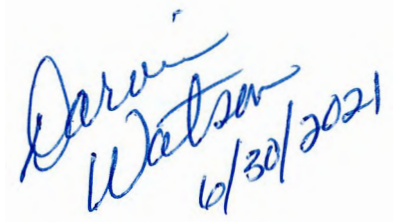

INVOICE

No. 134677
 04/14/2021

21-0137 New Buffalo Marina Repairs

Project Manager: Evan M LeDuc

Professional services completed through 3/31/2021:

	Contract Amount	Previously Invoiced	Current Invoice	Remaining Contract
410 Roof Assessment	\$1,200.00	\$1,200.00	\$0.00	\$0.00
520 Construction Docs	\$4,300.00	\$4,300.00	\$0.00	\$0.00
540 Bidding	\$3,350.00	\$0.00	\$3,350.00	\$0.00
Totals:	\$8,850.00	\$5,500.00	\$3,350.00	\$0.00

594-577-818.2

Invoice Amount

\$3,350.00

All invoices are due upon receipt. After 30 days, interest of 1.5% per month will be added to any unpaid balance.

If, upon receipt of an invoice from Abonmarche, the client has any questions, or if there are any discrepancies in the invoice, the Client shall identify the issue in writing within ten (10) days of its receipt. If no written objection is made within the ten (10) day period, any such objection shall be deemed waived.

Please remit to **Abonmarche Consultants, Inc.**
PO Box 1088
Benton Harbor, MI 49023

****NOTE: \$ 1,172.50 of the above invoiced amounts were dedicated to work unrelated to the original contracted fire damaged scope of work.**



Engineering • Architecture • Land Surveying

CITY OF NEW BUFFALO

Attn: Rich Killips
City Hall
224 W. Buffalo Street
New Buffalo, MI 49117

INVOICE

No. 134692
04/14/2021

21-0069 Sediment Control Feasibility Study

Project Manager: Michael C Morphey

Engineering Services through 3/31/2021

	Contract Amount	Previously Invoiced	Current Invoice	Remaining Contract
200 Initial Feasibility Study	\$4,800.00	\$4,800.00	\$0.00	\$0.00
250 Topographic & Boundary Survey	\$2,500.00	\$2,500.00	\$0.00	\$0.00
450 Pre-Application Mtg & EGLE Coord.	\$1,400.00	\$0.00	\$0.00	\$1,400.00
455 SESC Permitting	\$2,300.00	\$0.00	\$0.00	\$2,300.00
500 Final Design & Bid Package	\$7,500.00	\$0.00	\$4,144.50	\$3,355.50
540 Bidding & Contracting Assistance	\$2,600.00	\$0.00	\$0.00	\$2,600.00
700 Construction Admin (Part Time) and Staking	\$5,400.00	\$0.00	\$0.00	\$5,400.00
Totals:	\$26,500.00	\$7,300.00	\$4,144.50	\$15,055.50

101-298-818

Invoice Amount

\$4,144.50

All invoices are due upon receipt. After 30 days, interest of 1.5% per month will be added to any unpaid balance.

If, upon receipt of an invoice from Abonmarche, the client has any questions, or if there are any discrepancies in the invoice, the Client shall identify the issue in writing within ten (10) days of its receipt. If no written objection is made within the ten (10) day period, any such objection shall be deemed waived.

Please remit to **Abonmarche Consultants, Inc.**
PO Box 1088
Benton Harbor, MI 49023



Engineering • Architecture • Land Surveying

CITY OF NEW BUFFALO
City Hall
224 W. Buffalo Street
New Buffalo, MI 49117

RECEIVED
JUN 01 2021
CITY OF NEW BUFFALO

INVOICE
No. 135302
05/28/2021

21-0745 2021 Engineer of Record
Project Manager: Anthony C. McGhee

Mortgage Office Stormwater Review

Invoice Amount \$550.50

All invoices are due upon receipt. After 30 days, interest of 1.5% per month will be added to any unpaid balance.

If, upon receipt of an invoice from Abonmarche, the client has any questions, or if there are any discrepancies in the invoice, the Client shall identify the issue in writing within ten (10) days of its receipt. If no written objection is made within the ten (10) day period, any such objection shall be deemed waived.

Please remit to **Abonmarche Consultants, Inc.**
PO Box 1088
Benton Harbor, MI 49023

101-298818.2

*Dee Watson
7/14/2021*



Engineering • Architecture • Land Surveying

CITY OF NEW BUFFALO

City Hall
224 W. Buffalo Street
New Buffalo, MI 49117

RECEIVED

JUN 18 2021

CITY OF NEW BUFFALO

INVOICE

No. 135585

06/11/2021

21-0751 2021 Streets Resurfacing Project

Project Manager: Jason W. Marquardt

Completed pavement corings, final design, and coordination of the bidding advertisement. Professional Services completed through 05/31/2021.

Invoice Amount

\$5,049.60

All invoices are due upon receipt. After 30 days, interest of 1.5% per month will be added to any unpaid balance.

If, upon receipt of an invoice from Abonmarche, the client has any questions, or if there are any discrepancies in the invoice, the Client shall identify the issue in writing within ten (10) days of its receipt. If no written objection is made within the ten (10) day period, any such objection shall be deemed waived.

Please remit to **Abonmarche Consultants, Inc.**
PO Box 1088
Benton Harbor, MI 49023

403-903-976.2

D. Watson
6/28/2021



Engineering • Architecture • Land Surveying

*DeJalson
7/14/2021*

CITY OF NEW BUFFALO
Attn: Rich Killips
City Hall
224 W. Buffalo Street
New Buffalo, MI 49117

RECEIVED

JUN 21 2021

CITY OF NEW BUFFALO

INVOICE

No. 135615

06/15/2021

21-0069 Sediment Control Feasibility Study

Project Manager: Michael C Morphey

Engineering Services through 5/31/2021

	Contract Amount	Previously Invoiced	Current Invoice	Remaining Contract
200 Initial Feasibility Study	\$4,800.00	\$4,800.00	\$0.00	\$0.00
250 Topographic & Boundary Survey	\$2,500.00	\$2,500.00	\$0.00	\$0.00
450 Pre-Application Mtg & EGLE Coord.	\$1,400.00	\$714.00	\$516.00	\$170.00
455 SESC Permitting	\$2,300.00	\$0.00	\$0.00	\$2,300.00
500 Final Design & Bid Package	\$7,500.00	\$5,307.00	\$180.00	\$2,013.00
540 Bidding & Contracting Assistance	\$2,600.00	\$0.00	\$0.00	\$2,600.00
700 Construction Admin (Part Time) and Staking	\$5,400.00	\$0.00	\$0.00	\$5,400.00
Totals:	\$26,500.00	\$13,321.00	\$696.00	\$12,483.00

Invoice Amount

\$696.00

All invoices are due upon receipt. After 30 days, interest of 1.5% per month will be added to any unpaid balance.

If, upon receipt of an invoice from Abonmarche, the client has any questions, or if there are any discrepancies in the invoice, the Client shall identify the issue in writing within ten (10) days of its receipt. If no written objection is made within the ten (10) day period, any such objection shall be deemed waived.

Please remit to **Abonmarche Consultants, Inc.**
PO Box 1088
Benton Harbor, MI 49023

101-298-818.2

CLF

THE CURCIO LAW FIRM

16905 Birchview Drive
Nunica, Michigan 49448



INVOICE

Invoice # 339
Date: 07/01/2021
Due Upon Receipt

City of New Buffalo
224 West Buffalo Street New
Buffalo, MI 49117

7-00001-NB - General

Invoice Number	Services Commencing	Services Through	Service Fee
339	6/1/21	5/30/21	\$831.00

Watson
7/14/2021

INVOICE GL DISTRIBUTION REPORT
 POST DATES 06/10/2021 - 07/13/2021
 BOTH JOURNALIZED AND UNJOURNALIZED
 BOTH OPEN AND PAID

GL Number	Invoice Date	Vendor	Invoice Desc.	Invoice	Due Date	Amount	check #
Fund 101 GENERAL FUND							
Dept 000							
101-000-657.000	06/14/21	BOWMAR, ANDREA	DUPLICATE CITATION PAYMENT REFUND	061421	07/12/21	92.00	41597
						<u>92.00</u>	
Total For Dept 000							
Dept 101 LEGISLATIVE							
101-101-720.000	05/28/21	MML - WORKERS COMPENSATION FUN	WORKER'S COMP 2021 1ST INSTALLMENT	3260206	06/08/21	8.67	41508
						<u>8.67</u>	
Total For Dept 101 LEGISLATIVE							
Dept 172 EXECUTIVE							
101-172-716.000	06/16/21	BLUE CROSS BLUE SHIELD OF MICH	BLUE CROSS PPO 500 PLAN JULY 2021	061621	07/13/21	1,214.26	41605
101-172-716.000	07/09/21	BLUE CROSS BLUE SHIELD OF MICH	BLUE CROSS PPO 500 PLAN JULY 2021	070921	07/13/21	1,214.26	41641
101-172-720.000	05/28/21	MML - WORKERS COMPENSATION FUN	WORKER'S COMP 2021 1ST INSTALLMENT	3260206	06/08/21	104.65	41508
						<u>2,533.17</u>	
Total For Dept 172 EXECUTIVE							
Dept 215 CLERK							
101-215-716.000	06/16/21	BLUE CROSS BLUE SHIELD OF MICH	BLUE CROSS PPO 500 PLAN JULY 2021	061621	07/13/21	1,480.02	41605
101-215-716.000	07/09/21	BLUE CROSS BLUE SHIELD OF MICH	BLUE CROSS PPO 500 PLAN JULY 2021	070921	07/13/21	1,480.02	41641
101-215-720.000	05/28/21	MML - WORKERS COMPENSATION FUN	WORKER'S COMP 2021 1ST INSTALLMENT	3260206	06/08/21	60.74	41508
101-215-751.000	06/16/21	AMY FIDLER	REIMBURSEMENT/MEAL/GASOLINE	06/16/21	07/13/21	216.16	41635
101-215-801.000	06/17/21	MMTA	MMTA FALL CONFERENCE	4092	07/13/21	359.00	41678
101-215-962.000	06/16/21	AMY FIDLER	REIMBURSEMENT/MEAL/GASOLINE	06/16/21	07/13/21	13.24	41635
						<u>3,609.18</u>	
Total For Dept 215 CLERK							
Dept 253 TREASURER							
101-253-716.000	06/16/21	BLUE CROSS BLUE SHIELD OF MICH	BLUE CROSS PPO 500 PLAN JULY 2021	061621	07/13/21	1,290.04	41605
101-253-716.000	07/09/21	BLUE CROSS BLUE SHIELD OF MICH	BLUE CROSS PPO 500 PLAN JULY 2021	070921	07/13/21	1,290.04	41641
101-253-720.000	05/28/21	MML - WORKERS COMPENSATION FUN	WORKER'S COMP 2021 1ST INSTALLMENT	3260206	06/08/21	60.74	41508
101-253-756.000	06/29/21	CDW GOVERNMENT	MICROSOFT SURFACE BOOK AND HP LED M	F534822	07/13/21	1,457.89	41644
101-253-853.000	07/01/21	VYSKOCIL, KATHRYN	PHONE/VYSKOCIL/07/01/21	07/01/21	07/13/21	50.00	41710
101-253-903.000	05/28/21	SBF ENTERPRISES	POSTAGE PREPAYMENT SUMMER TAX BILLS	060421	06/08/21	987.60	41509
101-253-903.000	06/16/21	SBF ENTERPRISES	PRINTING SUMMER TAX BILLS	0135334	07/13/21	1,648.01	41614
101-253-903.000	06/17/21	SBF ENTERPRISES	ADD'L PRINTING OF TAX BILLS	0135352 B	07/13/21	484.36	41615
						<u>7,268.68</u>	
Total For Dept 253 TREASURER							
Dept 257 ASSESSOR							
101-257-818.000	06/30/21	SITTIG ASSESSMENT SERVICES LLC	ASSESSMENT SERVICES JUNE 2021	070621	07/13/21	2,142.50	41698
101-257-818.000	06/30/21	SITTIG ASSESSMENT SERVICES LLC	ASSESSMENT SERVICES MAY 2021	063021	07/13/21	2,142.50	41698
						<u>4,285.00</u>	
Total For Dept 257 ASSESSOR							
Dept 266 ATTORNEY							
101-266-826.300	06/30/21	CHARLES NICHOLAS CURCIO	LEGAL SERVICES MAY 2021	339	07/13/21	831.00	41645
						<u>831.00</u>	
Total For Dept 266 ATTORNEY							
Dept 276 CEMETERY							
101-276-969.000	07/01/21	PINE GROVE CEMETERY AUTHORITY	CEMETERY/07/01/21	07/01/21	07/13/21	2,500.00	41688
						<u>2,500.00</u>	
Total For Dept 276 CEMETERY							
Dept 298 GENERAL GOVERNMENT							
101-298-716.000	06/16/21	BLUE CROSS BLUE SHIELD OF MICH	BLUE CROSS PPO 500 PLAN JULY 2021	061621	07/13/21	90.12	41605
101-298-716.000	07/09/21	BLUE CROSS BLUE SHIELD OF MICH	BLUE CROSS PPO 500 PLAN JULY 2021	070921	07/13/21	1,912.35	41641
101-298-720.000	05/28/21	MML - WORKERS COMPENSATION FUN	WORKER'S COMP 2021 1ST INSTALLMENT	3260206	06/08/21	213.15	41508
101-298-728.000	06/22/21	STAPLES	OFFICE SUPPLIES/GEN GOV/POLICE	06/22/21	07/13/21	75.98	41699
101-298-751.000	06/16/21	GRIFFIN, NANCY	REIMBURSEMENT/MILEAGE/MEAL	06/16/21	07/13/21	224.00	41656
101-298-818.000	06/09/21	INTEGRA CERT. DOCUMENT DESTRU	DOCUMENT DESTRUCTION/GEN GOV	0027260590	07/13/21	52.74	41665
101-298-818.000	05/28/21	GENERAL CODE	ANNUAL MAINTENANCE	GC00113529	06/08/21	995.00	41538

INVOICE GL DISTRIBUTION REPORT
 POST DATES 06/10/2021 - 07/13/2021
 BOTH JOURNALIZED AND UNJOURNALIZED
 BOTH OPEN AND PAID

GL Number	Invoice Date	Vendor	Invoice Desc.	Invoice	Due Date	Amount	check #
Fund 101 GENERAL FUND							
Dept 298 GENERAL GOVERNMENT							
101-298-818.000	07/12/21	ON SOLVE	CODE RED ANNUAL FEE	15179452	07/13/21	1,680.00	
101-298-818.200	06/15/21	ABONMARCHE CONSULTANTS INC	SEDIMENT CONTROL FEASIBILITY STUDY	135615	07/13/21	696.00	41630
101-298-818.200	06/30/21	ABONMARCHE CONSULTANTS INC	SEDIMENT CONTROL FEASIBILITY STUDY	134692	07/13/21	4,144.50	41630
101-298-853.000	04/24/21	VERIZON WIRELESS	VERIZON/POLICE/PARK/STREET/GEN GOV/	9880416500	07/13/21	31.18	41612
101-298-854.000	06/15/21	J. P. GILLEN & ASSOCIATES/EDGE	IT SERVICES MAY 2021	1466	07/13/21	3,425.00	41666
101-298-854.100	06/04/21	ARCHIVESOCIAL	SOCIAL MEDIA ARCHIVING SUBSCRIPTION	16500	06/08/21	2,388.00	41513
101-298-854.200	04/24/21	VERIZON WIRELESS	VERIZON/POLICE/PARK/STREET/GEN GOV/	9880416500	07/13/21	133.86	41612
101-298-920.000	04/27/21	SEMCO ENERGY GAS CO.	SEMCO/GEN GOV/POLICE/04/27/21-05/26	0152517.500-05	07/13/21	62.68	41611
101-298-920.000	05/05/21	INDIANA MICHIGAN POWER	ELECTRIC/GAN GOV/POLICE/05/05/21-06	04342433929-05	07/13/21	472.27	41609
101-298-920.000	06/25/21	SEMCO ENERGY GAS CO.	SEMCO/06/28/21	06/28/21	07/13/21	22.05	41629
101-298-931.000	06/02/21	DOMESTIC UNIFORM RENTALS	BUILDING SUPPLIES/GEN GOV/06/02/21	0602219505	07/13/21	155.35	41650
101-298-931.000	06/16/21	DOMESTIC UNIFORM RENTALS	BUILDING SUPPLIES/GEN GOV/06/16/21	06162219505	07/13/21	155.35	41650
101-298-931.000	06/30/21	DOMESTIC UNIFORM RENTALS	CASES OF JUMBO TOILET TISSUE/GEN GOV	6/21/21	07/13/21	174.87	
101-298-931.000	06/30/21	DOMESTIC UNIFORM RENTALS	BUILDING SUPPLIES/GEN GOV/06/30/21	0630219505	07/13/21	155.35	
101-298-931.000	06/30/21	DOMESTIC UNIFORM RENTALS	JUMBO TOILES TISSUE ROLLS/GEN GOV/0	6/22/21	07/13/21	174.87	
101-298-943.000	06/09/21	ADAMS REMCO INC	EQUIPMENT RENTAL/GEN GOV	241760	07/13/21	363.51	41631
101-298-943.000	06/01/21	US BANK EQUIPMENT FINANCE	EQUIPMENT RENTAL/GEN GOV	445035124	07/13/21	239.68	41706
101-298-943.000	07/01/21	PITNEY BOWES INC	EQUIPMENT RENTAL/GEN GOV/07/01/21-0	1018329375	07/13/21	180.00	41689
101-298-962.000	06/28/21	SEVILLE INVESTMENTS, LLC	PARKING LEASE PAYMENT FROM BEER CHU	062821	06/28/21	12,000.00	41617
101-298-962.000	06/16/21	GRIFFIN, NANCY	REIMBURSEMENT/MILEAGE/MEAL	06/16/21	07/13/21	15.89	41656
Total For Dept 298 GENERAL GOVERNMENT						30,233.75	
Dept 305 POLICE							
101-305-716.000	06/16/21	BLUE CROSS BLUE SHIELD OF MICH	BLUE CROSS PPO 500 PLAN JULY 2021	061621	07/13/21	6,575.09	41605
101-305-716.000	06/14/21	BLUE CROSS BLUE SHIELD OF MICH	HEALTH INSURANCE--PPO 1000 PLAN JUL	124535108	07/13/21	3,294.18	41604
101-305-716.000	07/09/21	BLUE CROSS BLUE SHIELD OF MICH	HEALTH INSURANCE--PPO 1000 PLAN AUG	070821	07/13/21	2,842.31	41640
101-305-716.000	07/09/21	BLUE CROSS BLUE SHIELD OF MICH	BLUE CROSS PPO 500 PLAN JULY 2021	070921	07/13/21	6,262.36	41641
101-305-720.000	05/28/21	MML - WORKERS COMPENSATION FUND	WORKER'S COMP 2021 1ST INSTALLMENT	3260206	06/08/21	2,114.80	41508
101-305-728.000	06/22/21	STAPLES	OFFICE SUPPLIES/GEN GOV/POLICE	06/22/21	07/13/21	35.99	41699
101-305-751.000	06/19/21	OSELKA MARINA	GASOLINE/POLICE/06/19/21	1025514	07/13/21	138.86	41685
101-305-751.000	06/21/21	CLUSTER, MICHAEL	REIMBURSEMENT/MEAL/GASOLINE	06/21/21	07/13/21	10.00	41646
101-305-768.000	04/06/21	STAR UNIFORMS	UNIFORMS/POLICE	20532-1	07/13/21	847.35	41700
101-305-768.000	04/15/21	STAR UNIFORMS	UNIFORMS/POLICE	19989-1	07/13/21	66.00	41700
101-305-768.000	05/04/21	STAR UNIFORMS	UNIFORMS/POLICE	20889-1	07/13/21	320.70	41700
101-305-768.000	05/17/21	STAR UNIFORMS	UNIFORMS/POLICE	21418-1	07/13/21	226.00	41700
101-305-768.000	06/01/21	STAR UNIFORMS	UNIFORMS/POLICE	21939-1	07/13/21	224.85	41700
101-305-768.000	05/20/21	STAR UNIFORMS	UNIFORMS/POLICE	10562-2	07/13/21	79.88	41700
101-305-768.000	05/19/21	STAR UNIFORMS	UNIFORMS/POLICE	10554-2	07/13/21	70.95	41700
101-305-768.000	06/24/21	STAR UNIFORMS	UNIFORMS/POLICE	229571	07/13/21	259.80	41700
101-305-768.000	06/24/21	STAR UNIFORMS	UNIFORMS/POLICE	229561	07/13/21	164.85	41700
101-305-768.000	06/30/21	KIESLER POLICE SUPPLY	UNIFORMS/POLICE	IN169671	07/13/21	388.10	41671
101-305-768.100	04/16/21	PRECISION CARTRIDGE CO	9MM PRACTICE AMMO & 40 CAL AMMO	2386	07/13/21	1,180.00	41690
101-305-801.000	06/21/21	CLUSTER, MICHAEL	REIMBURSEMENT/MEAL/GASOLINE	06/21/21	07/13/21	87.67	41646
101-305-818.000	05/31/21	OCCUSCREEN, LLC	EMPLOYMENT COMPREHENSIVE SCREENING/	169755	06/10/21	140.00	41596
101-305-818.000	05/31/21	WORKING WELL	EMPLOYMENT DRUG SCREENING/POLICE/PA	00356247	07/13/21	70.00	41601
101-305-818.000	06/19/21	MICHIGAN STATE POLICE	LIVE SCAN/POLICE	551588309	07/13/21	129.75	41677
101-305-818.000	06/06/21	MICHIGAN STATE POLICE	FINGER PRINTING/POLICE	551587534	07/13/21	129.75	41677
101-305-818.000	06/07/21	LEXIPOL LLC	RENEWAL POLICE MANUAL 7-1-1-THRU 6-	INVLEX2873-2	06/08/21	2,223.00	41556
101-305-851.000	01/01/21	TELE-RAD INC	MAINTENANCE FEE/JAN-FEB-MAR-APR-MA	900235	07/13/21	343.80	41702
101-305-853.000	04/24/21	VERIZON WIRELESS	VERIZON/POLICE/PARK/STREET/GEN GOV/	9880416500	07/13/21	319.49	41612
101-305-853.000	07/01/21	CLUSTER, MICHAEL	PHONE/CLUSTER/07/01/21	07/01/21	07/13/21	50.00	41646
101-305-920.000	04/27/21	SEMCO ENERGY GAS CO.	SEMCO/GEN GOV/POLICE/04/27/21-05/26	0152517.500-05	07/13/21	62.68	41611
101-305-920.000	05/05/21	INDIANA MICHIGAN POWER	ELECTRIC/GAN GOV/POLICE/05/05/21-06	04342433929-05	07/13/21	472.28	41609

INVOICE GL DISTRIBUTION REPORT
 POST DATES 06/10/2021 - 07/13/2021
 BOTH JOURNALIZED AND UNJOURNALIZED
 BOTH OPEN AND PAID

GL Number	Invoice Date	Vendor	Invoice Desc.	Invoice	Due Date	Amount	check #
Fund 101 GENERAL FUND							
Dept 305 POLICE							
101-305-920.000	06/25/21	SEMCO ENERGY GAS CO.	SEMCO/06/28/21	06/28/21	07/13/21	22.05	41629
101-305-931.000	06/02/21	DOMESTIC UNIFORM RENTALS	BUILDING SUPPLIES/POLICE/06/02/21	0602219705	07/13/21	117.53	41650
101-305-931.000	06/16/21	DOMESTIC UNIFORM RENTALS	BUILDING SUPPLIES/POLICE/06/16/21	0616219705	07/13/21	117.53	41650
101-305-931.000	06/30/21	DOMESTIC UNIFORM RENTALS	BUILDING SUPPLIES/POLICE/06/30/21	0660219705	07/13/21	117.53	
101-305-934.000	06/14/21	NEW BUFFALO HARDWARE	OFFICE REPAIR/POLICE	B75130	07/13/21	10.99	
101-305-934.000	05/19/21	CDW GOVERNMENT	DISPLAY MOUNT AND PARTS/POLICE	D421722	07/13/21	291.86	41607
101-305-939.000	05/05/21	RIDGE AUTO PARTS	COATS TIRE CHANGING MACHINE	434065	07/13/21	1,174.75	41610
101-305-939.000	05/18/21	RIDGE AUTO PARTS	MAINTENANCE/POLICE	435090	07/13/21	34.74	41610
101-305-939.000	06/23/21	RIDGE AUTO PARTS	VEHICLE REPAIR/POLICE/06/23/21	437198	07/13/21	47.37	41692
101-305-939.000	06/24/21	NEW BUFFALO HARDWARE	VEHICLE REPIAR/POLICE	A199488	07/13/21	7.60	
101-305-943.000	06/17/21	PARRETT COMPANY	EQUIPMENT RENTAL/POLICE	58998	07/13/21	101.72	41687
101-305-983.000	07/06/21	ENTERPRISE FM TRUST	INSP SERVICES & POLICE VEHICLE LEAS	070621	06/08/21	558.97	
Total For Dept 305 POLICE						31,733.13	
Dept 336 FIRE							
101-336-720.000	05/28/21	MML - WORKERS COMPENSATION FUND	WORKER'S COMP 2021 1ST INSTALLMENT	3260206	06/08/21	318.97	41508
101-336-818.000	06/30/21	OCCUSCREEN, LLC	NEW HIRE COMPREHENSIVE SCREENING/FI	17112	07/13/21	70.00	41684
101-336-818.000	07/01/21	NEW BUFFALO TOWNSHIP	CONTRACTED FIRE SERVICE/07/01/21	07/01/21	07/13/21	2,000.00	
101-336-853.000	07/01/21	HUSTON, CHRISTOPHER	PHONE/HUSTON/07/01/21	07/01/21	07/13/21	50.00	41663
101-336-931.000	06/30/21	E.I. CONSTRUCTION	ROOF REPLACE ON HOSE TOWER	063021	07/13/21	2,200.00	41624
101-336-933.000	05/14/21	NATIONAL HOSE TESTING SPECIALTY	NFPA TESTING	00109-2	06/10/21	1,357.40	41595
101-336-933.000	04/23/21	EMERGENCY VEHICLES PLUS	PUMP TESTING	06/17/21	07/13/21	1,664.14	41652
101-336-933.000	06/22/21	BREATHING AIR SYSTEMS	BREATHING AIR COMP SERVICED/FIRE	1L74198	07/13/21	504.75	41643
101-336-979.000	06/06/21	DARLEY & CO, WS	REPLACEMENT HOSES FOR FIRE TRUCKS	17435811	07/13/21	1,948.00	41649
101-336-979.000	03/25/21	APPOLO FIRE EQUIPMENT	HURST HYD FLUID/FIRE	105279	07/13/21	146.05	41637
101-336-979.000	06/28/21	DARLEY & CO, WS	HOSE RAMP/FIRE	17437705	07/13/21	1,028.30	41649
101-336-979.000	06/30/21	HEI WIRELESS	INSTALLATION RADIOS /FIRE	102368	07/13/21	480.00	41662
Total For Dept 336 FIRE						11,767.61	
Dept 371 INSPECTION SERVICES							
101-371-716.000	06/16/21	BLUE CROSS BLUE SHIELD OF MICH	BLUE CROSS PPO 500 PLAN JULY 2021	061621	07/13/21	779.88	41605
101-371-716.000	07/09/21	BLUE CROSS BLUE SHIELD OF MICH	BLUE CROSS PPO 500 PLAN JULY 2021	070921	07/13/21	779.88	41641
101-371-728.000	07/09/21	GROSSE, GAIL	REIMB FOR OFFICE SUPPLIES	071221	07/13/21	7.42	41657
101-371-756.000	06/29/21	CDW GOVERNMENT	MICROSOFT SURFACE BOOK AND HP LED M	F534822	07/13/21	1,101.61	41644
101-371-983.000	07/06/21	ENTERPRISE FM TRUST	INSP SERVICES & POLICE VEHICLE LEAS	070621	06/08/21	440.72	
Total For Dept 371 INSPECTION SERVICES						3,109.51	
Dept 442 STREET OPERATING							
101-442-716.000	06/16/21	BLUE CROSS BLUE SHIELD OF MICH	BLUE CROSS PPO 500 PLAN JULY 2021	061621	07/13/21	4,677.94	41605
101-442-716.000	07/09/21	BLUE CROSS BLUE SHIELD OF MICH	BLUE CROSS PPO 500 PLAN JULY 2021	070921	07/13/21	3,584.00	41641
101-442-720.000	05/28/21	MML - WORKERS COMPENSATION FUND	WORKER'S COMP 2021 1ST INSTALLMENT	3260206	06/08/21	2,347.02	41508
101-442-756.000	06/11/21	RIDGE AUTO PARTS	OPERATING SUPPLIES/STREET/06/11/21	436517	07/13/21	13.45	41692
101-442-756.000	05/07/21	RIDGE AUTO PARTS	ENGINE DEGREASER/STREET	434507-2	07/13/21	13.96	41610
101-442-756.000	06/15/21	NEW BUFFALO HARDWARE	OPERATING SUPPLIES/STREET	A197675	07/13/21	16.47	
101-442-756.000	06/22/21	PRAXAIR DISTRIBUTION INC	CYLINDER RENTAL/STREET	64330289	07/13/21	98.86	
101-442-756.000	06/24/21	NEW BUFFALO HARDWARE	OPERATING SUPPLIES/STREET	A199519	07/13/21	51.59	
101-442-756.000	06/25/21	NEW BUFFALO HARDWARE	OPERATING SUPPLIES/STREET	A199639	07/13/21	9.99	
101-442-767.000	06/29/21	NEW BUFFALO HARDWARE	EQUIPMENT/STREET	A200351	07/13/21	36.78	
101-442-768.000	05/07/21	ALEX SMEYERS	CLOTHING ALLOWANCE/SMEYERS/STREET	06/21/21	07/13/21	384.02	41632
101-442-768.000	06/29/21	SCHULTZ, FRED	CLOTHING ALLOWANCE RIMBURSEMENT/SCH	06/29/21	07/13/21	161.45	41696
101-442-818.000	07/01/21	LAKESHORE RECYCLING & DISPOSAL	DUMPSTER COLLECTION	12675JUL	06/08/21	116.00	41554
101-442-853.000	04/24/21	VERIZON WIRELESS	VERIZON/POLICE/PARK/STREET/GEN GOV/	9880416500	07/13/21	40.01	41612
101-442-853.000	07/01/21	BOLTON, JOSHUA	PHONE/BOLTON/07/01/21	07/01/21	07/13/21	50.00	41642

INVOICE GL DISTRIBUTION REPORT
 POST DATES 06/10/2021 - 07/13/2021
 BOTH JOURNALIZED AND UNJOURNALIZED
 BOTH OPEN AND PAID

GL Number	Invoice Date	Vendor	Invoice Desc.	Invoice	Due Date	Amount	check #
Fund 101 GENERAL FUND							
Dept 442 STREET OPERATING							
101-442-903.000	05/30/21	HERALD PALLADIUM	STREET RESURFACING PROJECT/STREET/	00014704-05	07/13/21	226.31	41599
101-442-920.000	06/01/21	INDIANA MICHIGAN POWER	ELECTRIC/CONSOLIDATED/STREETS/06/01	0470660755-06	07/13/21	357.51	41619
101-442-920.000	07/02/21	COMCAST	COMCAST STREETS DEPT	070221	07/13/21	202.05	41621
101-442-920.000	07/06/21	COMCAST	COMCAST STREETS DEPT JUL 9 THRU AU	070621	07/13/21	513.20	41623
101-442-931.000	06/02/21	DOMESTIC UNIFORM RENTALS	BUILDING SUPPLIES/STREETS/06/02/21	06022110105	07/13/21	66.21	41650
101-442-931.000	06/16/21	DOMESTIC UNIFORM RENTALS	BUILDING SUPPLIES/GARAGE/06/16/21	0616210105	07/13/21	66.21	41650
101-442-931.000	06/30/21	DOMESTIC UNIFORM RENTALS	BUIDING SUPPLIES/STREET/06/30/21	0630210105	07/13/21	66.46	
101-442-932.000	06/29/21	VERSAW EARTHWORKS LLC	STONE DELIVERY X2/STREET	1365	07/13/21	1,157.50	41709
101-442-932.000	06/30/21	SANISWEEP, INC	STREET SWEEPING/STREET	102050	07/13/21	1,050.00	41695
101-442-932.000	06/10/21	NATURE'S WAY LANDSCAPING	DOWNTOWN STREETScape MAINT 2ND INST.	061021	07/12/21	2,829.03	41592
101-442-933.000	06/15/21	MTECH	EQUIPMENT REPAIR/STREET/06/15/21	IN212584	07/13/21	696.32	41680
101-442-933.000	06/25/21	NEW BUFFALO HARDWARE	EQUIPMENT/STREET	A199689	07/13/21	19.48	41682
101-442-933.000	06/30/21	RIDGE AUTO PARTS	BATTERY/STREET	437634	07/13/21	102.32	
101-442-935.100	06/14/21	BARRETT, ELIZABETH	CLEANING REIMB FOR SEWER PIPE BURST	061421	07/13/21	99.00	41603
101-442-935.100	06/30/21	B AND Z COMPANY	STORM WATER PUMP OUT	210659	07/13/21	2,357.50	41638
101-442-939.000	05/05/21	RIDGE AUTO PARTS	COATS TIRE CHANGING MACHINE	434065	07/13/21	1,174.75	41610
101-442-939.000	06/24/21	THREE OAKS FORD	VEHICLE REPAIR/STREET/06/24/21	145611CITB99	07/13/21	97.44	41703
101-442-939.000	06/25/21	THREE OAKS FORD	VEHICLE REPAIR/STREET/06/25/21	145615CITB99	07/13/21	97.44	41703
Total For Dept 442 STREET OPERATING						22,780.27	
Dept 448 STREET LIGHTING							
101-448-926.000	06/01/21	INDIANA MICHIGAN POWER	ELECTRIC/CONSOLIDATED/STREET LIGHT	04459418614-06	07/13/21	142.13	41619
101-448-926.000	06/30/21	INDIANA MICHIGAN POWER	ELECTRIC/STREET LIGHTING/	04023785704-06	07/13/21	1,796.46	41627
Total For Dept 448 STREET LIGHTING						1,938.59	
Dept 523 SOLID WASTE COLLECTION							
101-523-818.000	07/01/21	LAKESHORE RECYCLING & DISPOSAL	DUMPSTER SERVICE/AUG-2021	126368 AUG	07/13/21	1,027.00	41673
101-523-818.000	07/01/21	LAKESHORE RECYCLING & DISPOSAL	WEEKLY CURBSIDE GARBAGE PICK UP/AUG	126369	07/13/21	21,120.28	41673
101-523-818.000	07/01/21	LAKESHORE RECYCLING & DISPOSAL	DUMPSTER COLLECTION	12675JUL	06/08/21	188.00	41554
101-523-818.000	07/01/21	LAKESHORE RECYCLING & DISPOSAL	WEEKLY CURBSIDE GARBAGE PICKUP/07/0	12675JUL-2	06/08/21	21,120.28	41554
Total For Dept 523 SOLID WASTE COLLECTION						43,455.56	
Dept 651 AMBULANCE SERVICE							
101-651-818.000	06/01/21	MEDIC 1	AMBULANCE/06/01/21	06/01/21	07/13/21	9,283.42	41674
Total For Dept 651 AMBULANCE SERVICE						9,283.42	
Dept 872 OTHER FUNCTIONS							
101-872-818.000	06/08/21	BERRIEN COUNTY TREASURER	COMPUTERIZED TAX SERVICES FOR 2021	11010	06/08/21	4,010.00	41518
Total For Dept 872 OTHER FUNCTIONS						4,010.00	
Total For Fund 101 GENERAL FUND						179,439.54	
Fund 208 PARK FUND							
Dept 000							
208-000-655.100	06/15/21	GRZYBOWSKI, SCOTT	PAVILLION RENTAL DEPOSIT REFUND	062821	07/13/21	25.00	41660
Total For Dept 000						25.00	
Dept 691 PARK							
208-691-716.000	06/16/21	BLUE CROSS BLUE SHIELD OF MICH	BLUE CROSS PPO 500 PLAN JULY 2021	061621	07/13/21	1,600.53	41605
208-691-716.000	07/09/21	BLUE CROSS BLUE SHIELD OF MICH	BLUE CROSS PPO 500 PLAN JULY 2021	070921	07/13/21	1,157.80	41641
208-691-720.000	05/28/21	MML - WORKERS COMPENSATION FUN	WORKER'S COMP 2021 1ST INSTALLMENT	3260206	06/08/21	705.32	41508
208-691-722.000	06/30/21	WORKING WELL	DRUG SCREEN AND DOT RECERTIFICATION/	00358444-00	07/13/21	35.00	41711
208-691-728.000	06/11/21	NEW BUFFALO HARDWARE	OFFICE SUPPLIES/PARK	B74883	07/13/21	1.49	
208-691-756.000	06/19/21	NEW BUFFALO HARDWARE	OPERATING SUPPLIES/PARK	A198577	07/13/21	16.07	

INVOICE GL DISTRIBUTION REPORT
 POST DATES 06/10/2021 - 07/13/2021
 BOTH JOURNALIZED AND UNJOURNALIZED
 BOTH OPEN AND PAID

GL Number	Invoice Date	Vendor	Invoice Desc.	Invoice	Due Date	Amount	check #
Fund 208 PARK FUND							
Dept 691 PARK							
208-691-756.000	06/21/21	MENARDS	OPERATING SUPPLIES/PARK	79270	07/13/21	98.32	41675
208-691-756.000	06/22/21	AMERICAN SAFETY & FIRST AID	FIRST AID SUPPLIES/LIFEGUARD/06/22/	7.12106-IN	07/13/21	60.68	41634
208-691-767.000	06/17/21	NEW BUFFALO HARDWARE	EQUIPMENT/PARK	A198169	07/13/21	23.78	
208-691-767.000	06/22/21	NEW BUFFALO HARDWARE	EQUIPMENT/PARK	A199008	07/13/21	4.98	
208-691-767.000	06/24/21	NEW BUFFALO HARDWARE	EQUIPMENT/PARK	B75978	07/13/21	3.40	
208-691-767.000	06/21/21	GLASDON INC	LIFE RING HOUSING/LIFE RING/ROPE/BE.	SL1009200	07/13/21	482.50	41655
208-691-767.000	06/30/21	NEW BUFFALO HARDWARE	SMALL TOOLS/PARK	A2000599	07/13/21	33.99	
208-691-818.000	05/31/21	OCCUSCREEN, LLC	EMPLOYMENT COMPREHENSIVE SCREENING/	169755	06/10/21	163.00	41596
208-691-818.000	05/31/21	WORKING WELL	EMPLOYMENT DRUG SCREENING/POLOCE/PA.	00356247	07/13/21	175.00	41601
208-691-818.000	06/14/21	PRIDE THE PORTABLE TOILET COM	TOILET RENTAL/JUNE EXTRA SERVICES/P.	24626	07/13/21	480.00	41691
208-691-818.000	05/28/21	PRIDE THE PORTABLE TOILET COM	TOILET RENTAL/OSELKA/PARK/05/28/21-	24313	07/13/21	90.00	41691
208-691-818.000	05/28/21	PRIDE THE PORTABLE TOILET COM	TOILET RENTAL/DOG PARK/05/28/21-06/	24311	07/13/21	90.00	41691
208-691-818.000	05/24/21	PRIDE THE PORTABLE TOILET COM	TOILET RENTAL BETWEEN SUBWAY AND CI	24231	07/13/21	500.00	41691
208-691-818.000	06/30/21	E.I. CONSTRUCTION	PLUMBING REPAIRS--PARKS	062921	07/13/21	1,165.00	41651
208-691-818.000	07/01/21	LAKESHORE RECYCLING & DISPOSAL	DUMPSTER COLLECTION	12675JUL	06/08/21	629.00	41554
208-691-818.000	07/12/21	E.I. CONSTRUCTION	PLUMBING REPAIR AT BEACH MEN'S BATH	071321	07/13/21	150.00	
208-691-853.000	04/24/21	VERIZON WIRELESS	VERIZON/POLICE/PARK/STREET/GEN GOV/	9880416500	07/13/21	130.49	41612
208-691-853.000	07/01/21	D'AMICO KRISTEN	PHONE/D'AMICO/07/01/21	07/01/21	07/13/21	50.00	41648
208-691-920.000	05/05/21	INDIANA MICHIGAN POWER	ELECTRIC/BEACH/05/05/21-06/04/21	04523676007-05	07/13/21	13.56	41609
208-691-920.000	06/01/21	INDIANA MICHIGAN POWER	ELECTRIC/PARKS/CONSOLIDATED/06/01/2	04546766223-06	07/13/21	1,077.03	41619
208-691-920.000	06/25/21	SEMCO ENERGY GAS CO.	SEMCO/06/28/21	06/28/21	07/13/21	15.47	41629
208-691-920.000	06/30/21	NEW BUFFALO TOWNSHIP	WATER/DOG PARK/05/01/21-06/30/21	06/30/21	07/13/21	56.99	41683
208-691-931.000	06/02/21	DOMESTIC UNIFORM RENTALS	BUILDING SUPPLIES/BEACH/06/02/21	0602210505	07/13/21	69.18	41650
208-691-931.000	06/02/21	DOMESTIC UNIFORM RENTALS	BUILDING SUPPLIES/OSELKA/PARK/06/02	0602210525	07/13/21	76.70	41650
208-691-931.000	06/16/21	DOMESTIC UNIFORM RENTALS	BUILDING SUPPLIES/OSELKA/PARK/06/16	0616210525	07/13/21	76.70	41650
208-691-931.000	06/16/21	DOMESTIC UNIFORM RENTALS	BUILDING SUPPLIES/BEACH/06/16/21	0616210505	07/13/21	69.18	41650
208-691-931.000	06/29/21	MODEL COVERALL	VYNIL GLOVES/PARK	S0970509	07/13/21	120.00	41679
208-691-931.000	06/30/21	DOMESTIC UNIFORM RENTALS	BUILDING SUPPLIES/BEACH/PARK/06/30	0630210505	07/13/21	69.18	
208-691-931.000	06/30/21	DOMESTIC UNIFORM RENTALS	BUILDING SUPPLIES/OSELKA PARK/06/30	0630210525	07/13/21	76.70	
208-691-932.000	06/22/21	NEW BUFFALO HARDWARE	GROUPS REPAIR/PARK	A199173	07/13/21	29.98	41682
208-691-932.000	06/29/21	NEW BUFFALO HARDWARE	GROUPS REPAIR/PARK	B76398	07/13/21	4.68	
208-691-932.000	06/22/21	TRUGREEN PROCESSING CENTER	LAWN SERVICE/BASEBALL FIELDS/06/22/	141476978	07/13/21	197.00	41705
208-691-932.000	06/22/21	TRUGREEN PROCESSING CENTER	GRUB PREVENTION/BASEBALL FIELDS/06/	141477049	07/13/21	240.00	41705
208-691-932.000	06/30/21	NEW BUFFALO HARDWARE	GROUPS REPAIR/PARK	A200568	07/13/21	1.32	41682
208-691-932.000	06/01/21	NEW BUFFALO HARDWARE	GROUPS MAINTENANCE/PARK	B74088	07/13/21	37.95	41682
208-691-933.000	06/10/21	THIRD COAST SURF SHOP	LIFE JACKET (COST COVERED BY GRANT	1005-2021	07/12/21	546.76	41593
208-691-933.000	05/28/21	RIDGE AUTO PARTS	LEAF VAC REPAIR/STREET	435746	07/13/21	311.38	41610
208-691-933.000	07/01/21	TOTAL PARKING SOLUTIONS	MAINTENANCE AND INSPECTION FOR 3 PA	105370	07/13/21	2,040.00	41704
208-691-933.100	04/01/21	TOTAL PARKING SOLUTIONS	PARKING TERMINAL RECEIPT PAPER	105243	06/28/21	320.00	41618
208-691-933.100	07/01/21	TOTAL PARKING SOLUTIONS	WEB MONITORING/08/01/21-07/31/22	105371	07/13/21	2,880.00	41704
208-691-933.200	07/06/21	JOHN DEERE FINANCIAL	EQUIPMENT RENTAL/JD UTILITY TRACTOR	2514680	07/13/21	940.66	41625
208-691-933.200	07/07/21	JOHN DEERE FINANCIAL	EQUIPMENT LEASE/JD LOADER/PARK	2514681	07/13/21	142.94	41626
208-691-939.000	05/05/21	RIDGE AUTO PARTS	COATS TIRE CHANGING MACHINE	434065	07/13/21	1,174.75	41610
208-691-979.000	05/28/21	CDW GOVERNMENT	BATTERIES/PARK	D879100	07/13/21	175.29	41644
208-691-979.000	07/01/21	CDW GOVERNMENT	EQUIPMENT/PARK	F063837	07/13/21	274.80	41644
Total For Dept 691 PARK						18,884.55	
Total For Fund 208 PARK FUND						18,909.55	
Fund 402 EQUIPMENT PURCHASE FUND							
Dept 902 CAPITAL							
402-902-981.200	07/01/21	WELLS FARGO VENDOR FIN SERV	TOOL CAT AND SWEEPER/PARKS/STREET/0	5015577899	07/13/21	714.95	41620
402-902-981.300	06/15/21	KASSOBOHRER ALL TERRAIN VEHIC	BEACH TECH 2000 BEACH CLEANING MACH	90413303	07/13/21	50,500.00	41668

INVOICE GL DISTRIBUTION REPORT
 POST DATES 06/10/2021 - 07/13/2021
 BOTH JOURNALIZED AND UNJOURNALIZED
 BOTH OPEN AND PAID

GL Number	Invoice Date	Vendor	Invoice Desc.	Invoice	Due Date	Amount	check #
Fund 402 EQUIPMENT PURCHASE FUND							
Dept 902 CAPITAL							
402-902-981.300	07/01/21	WELLS FARGO VENDOR FIN SERV	TOOL CAT AND SWEEPER/PARKS/STREET/0	5015577899	07/13/21	476.63	41620
Total For Dept 902 CAPITAL						51,691.58	
Total For Fund 402 EQUIPMENT PURCHASE FUND						51,691.58	
Fund 590 SEWER FUND							
Dept 537 SEWER							
590-537-836.100	06/30/21	GRSD SEWER AUTHORITY	INSTALL AND TEST HIGH WETWELL FLOAT	0000012022	07/13/21	289.04	41658
590-537-920.000	05/06/21	INDIANA MICHIGAN POWER	ELECTRIC/WATER/05/06/21-06/04/21	04002186031-05	07/13/21	17.05	41609
Total For Dept 537 SEWER						306.09	
Total For Fund 590 SEWER FUND						306.09	
Fund 591 WATER FUND							
Dept 536 WATER							
591-536-716.000	06/16/21	BLUE CROSS BLUE SHIELD OF MICH	BLUE CROSS PPO 500 PLAN JULY 2021	061621	07/13/21	6,627.84	41605
591-536-716.000	07/09/21	BLUE CROSS BLUE SHIELD OF MICH	BLUE CROSS PPO 500 PLAN JULY 2021	070921	07/13/21	6,531.56	41641
591-536-720.000	05/28/21	MML - WORKERS COMPENSATION FUN	WORKER'S COMP 2021 1ST INSTALLMENT	3260206	06/08/21	1,468.60	41508
591-536-728.000	06/09/21	MENARDS	OFFICE SUPPLIES/WATER	78466	07/13/21	82.20	41675
591-536-753.000	06/21/21	ALEXANDER CHEMICAL CORP	BLANKET WATER CHEMICAL PURCHASES	40887	07/13/21	1,815.25	41633
591-536-753.000	06/29/21	ALEXANDER CHEMICAL CORP	BLANKET WATER CHEMICAL PURCHASES	41246	07/13/21	3,247.53	41633
591-536-756.000	06/11/21	ETNA SUPPLY COMPANY	OPERATING SUPPLIE/WATER	S104003509.002	07/13/21	1,410.17	41653
591-536-756.000	06/14/21	NEW BUFFALO HARDWARE	OPERATING SUPPLIES/WATER	B75189	07/13/21	25.08	
591-536-756.000	06/27/21	MENARDS	OPERATING SUPPLIES/WATER	7684	07/13/21	8.46	41675
591-536-756.100	06/16/21	SEIFERT'S FARM SUPPLY	WATER TAP SUPPLIES/WATER	216897	07/13/21	106.00	41697
591-536-756.200	05/27/21	ETNA SUPPLY COMPANY	METER REPLACEMENT/WATER	S104049668.001	07/13/21	185.00	41653
591-536-756.300	06/10/21	ENVIRONMENTAL RESOURCE ASSOC	TESTING SUPPLIES/WATER	C455001	07/13/21	186.01	41608
591-536-756.300	06/16/21	PARAGON LABORATORIES INC	TESTING SUPPLIES/WATER	42540-2200485	07/13/21	184.00	41686
591-536-756.300	06/15/21	STATE OF MICHIGAN DEQ	MISC TESTING/WATER	76110623629	07/13/21	720.00	41701
591-536-756.400	06/23/21	IDEXX DISTRIBUTION CORP	LAB SUPPLIES/WATER	3087227295	07/13/21	787.55	41664
591-536-756.400	06/09/21	HACH COMPANY	LAB SUPPLIES/WATER	12492691	07/13/21	620.75	41661
591-536-756.400	06/14/21	USA BLUEBOOK	LAB SUPPLIES/WATER	633286	07/13/21	427.17	41707
591-536-767.000	06/11/21	NEW BUFFALO HARDWARE	EQUIPMENT/WATER	A196937	07/13/21	21.99	
591-536-767.000	07/02/21	HACH COMPANY	EQUIPMENT/WATER	12531274	07/13/21	375.12	41661
591-536-818.000	06/30/21	WORKING WELL	DRUG SCREEN AND DOT RECERTIFACTION/	00358444-00	07/13/21	75.00	41711
591-536-818.000	05/24/21	ESRI INC	ARC GIS RENEWAL 07/01/21-06/30/22	94024905	06/08/21	1,500.00	41535
591-536-818.000	07/01/21	LAKESHORE RECYCLING & DISPOSAL	DUMPSTER COLLECTION	12675JUL	06/08/21	94.00	41554
591-536-818.000	07/01/21	COUNTRY LANE REMODELING/MIKE I	MOWING/WATER STREET/WATER PLANT	1777	07/13/21	130.00	41647
591-536-818.000	07/06/21	KENNETH L KORP	PEST REMOVAL AND INSPECTION/WATER	07/06/21	07/13/21	400.00	41670
591-536-818.600	07/06/21	ETNA SUPPLY COMPANY	CONTRACTUAL WATER TAPS/WATER	S104076102.001	07/13/21	842.00	41653
591-536-853.000	05/02/21	AT&T	PHONE/WATER/05/02/21-06/01/21	269R01267206-05	07/13/21	118.42	41606
591-536-853.000	05/02/21	AT&T	PHONE/WATER/05/02/21-06/01/21	269R07012106-05	07/13/21	285.91	41606
591-536-853.000	05/02/21	AT&T	PHONE/WATER/05/02/21-06/01/21	906R18086806	07/13/21	70.67	41606
591-536-853.000	05/05/21	AT&T	PHONE/WATER/05/05/21-06/04/21	269469853103-05	07/13/21	52.03	41606
591-536-853.000	07/01/21	ANDERSON, KENNETH	PHONE/ANDERSON/07/01/21	07/01/21	07/13/21	50.00	41636
591-536-853.000	07/01/21	GRUENER, ROBERT	PHONE /GRUENER/07/01/21	07/01/21	07/13/21	50.00	41659
591-536-853.000	07/01/21	JOHNSON, JEFFREY	PHONE/JOHNSON/07/01/21	07/01/21	07/13/21	50.00	41667
591-536-853.000	07/12/21	AT&T	PHONE SERVICE WATER DEPT	071221	07/13/21	569.86	
591-536-920.000	05/06/21	INDIANA MICHIGAN POWER	ELECTRIC/WATER/05/06/21-06/04/21	04909113708-05	07/13/21	18.68	41609
591-536-920.000	06/01/21	INDIANA MICHIGAN POWER	ELECTRIC/CONSOLIDATED/WATER/06/01/2	04354696801-06	07/13/21	712.82	41619
591-536-920.000	07/02/21	COMCAST	COMCAST WATER PLANT	070121	07/13/21	237.84	41622
591-536-931.000	06/02/21	DOMESTIC UNIFORM RENTALS	BUILDING SUPPLIES/WATER/06/02/21	0602210005	07/13/21	43.56	41650
591-536-931.000	06/16/21	DOMESTIC UNIFORM RENTALS	BUILDING SUPPLIES/WATER/06/16/21	0616210005	07/13/21	43.56	41650

INVOICE GL DISTRIBUTION REPORT
 POST DATES 06/10/2021 - 07/13/2021
 BOTH JOURNALIZED AND UNJOURNALIZED
 BOTH OPEN AND PAID

GL Number	Invoice Date	Vendor	Invoice Desc.	Invoice	Due Date	Amount	check #
Fund 591 WATER FUND							
Dept 536 WATER							
591-536-931.000	06/25/21	RIDGE AUTO PARTS	BUILDING MAINTENANCE/WATER/06/25/21	437352	07/13/21	147.30	41692
591-536-931.000	06/30/21	DOMESTIC UNIFORM RENTALS	BUILDING SUPPLIES/WATER/06/30/21	0630210005	07/13/21	43.56	
591-536-933.000	06/16/21	KENDALL ELECTRIC	MAINTENANCE/WATER	S110422689.001	07/13/21	900.00	41669
591-536-933.000	06/15/21	RUNKLE ELECTRIC	REMOVE AND REPLACE VFR/WATER	210610	07/13/21	625.00	41693
591-536-933.000	06/30/21	KENDALL ELECTRIC	POWER FLEX 400 UFD DRIVE	S110402757.001	07/13/21	6,322.68	41669
591-536-939.000	05/05/21	RIDGE AUTO PARTS	COATS TIRE CHANGING MACHINE	434065	07/13/21	1,174.75	41610
Total For Dept 536 WATER						39,387.92	
Total For Fund 591 WATER FUND						39,387.92	
Fund 594 HARBOR OPERATIONS							
Dept 597 HARBOR OPERATIONS							
594-597-756.000	06/22/21	AMERICAN SAFETY & FIRST AID	FIRST AID SUPPLIES/BOAT LAUNCH/06/2	7.12105-IN	07/13/21	20.17	
594-597-756.000	06/30/21	NEW BUFFALO HARDWARE	OPERATING SUPPLIES/BOAT RAMP/HARB	A200577	07/13/21	6.49	
594-597-756.000	07/02/21	AMERICAN SAFETY & FIRST AID	MEDICAL SUPPLIES/BOAT LAUNCH/HARB	712206-IN	07/13/21	42.14	
594-597-767.000	06/21/21	GLASDON INC	LIFE RING HOUSING/LIFE RING/ROPE/MA	SL1009200-2	07/13/21	482.50	
594-597-818.000	06/17/21	MEAD & WHITE ELECTRICAL	ELECTRICAL REPAIRS--MARINA	10735-3	07/13/21	3,630.30	
594-597-818.000	06/17/21	MEAD & WHITE ELECTRICAL	ELECTRICAL REPAIRS--MARINA	10735-2	07/13/21	8,341.20	
594-597-818.000	05/08/21	PRIDE THE PORTABLE TOILET COM	TOILET RENTAL/BOAT LAUNCH/05/08/21-	24312	07/13/21	90.00	
594-597-818.000	06/03/21	JOY'S JOHNS	TOILET AND SINK RENTAL/MARINA/06/01	PS378747	07/13/21	326.42	
594-597-818.000	06/30/21	OCCUSCREEN, LLC	RENEWAL SCREENING/MARINA	171312-2	07/13/21	31.00	
594-597-818.000	07/01/21	JOY'S JOHNS	2 FLUSHABLE TOILETS/1 HAND WASH/07/	PS385394	07/13/21	265.17	
594-597-818.200	06/30/21	ABONMARCHE CONSULTANTS INC	MARINA REPAIR	134677	07/13/21	3,350.00	
594-597-920.000	07/06/21	COMCAST	COMCAST BOART RAMP JUNE	070421	07/13/21	80.92	5044
594-597-920.000	07/06/21	COMCAST	COMCAST BOART RAMP JULY	070321	07/13/21	80.92	5044
594-597-920.000	07/06/21	COMCAST	COMCAST MARINA JUL 7 THRU AUG 6	070521	07/13/21	499.09	5045
594-597-931.000	06/02/21	DOMESTIC UNIFORM RENTALS	BUILDING SUPPLIES/MARINA/HARB/06/02	0602210515	07/13/21	74.47	
594-597-931.000	06/02/21	DOMESTIC UNIFORM RENTALS	BUILDING SUPPLIES/BOAT RAMP/HARB/06	0602210535	07/13/21	45.20	
594-597-931.000	06/22/21	CITY PLUMBING & HEATING CO	BUILDING REPAIR/MARINA/6/22/21	058495	07/13/21	1,418.54	
594-597-931.000	06/16/21	DOMESTIC UNIFORM RENTALS	BUILDING SUPPLIES/MARINA/06/16/21/H	0616210515	07/13/21	74.47	
594-597-931.000	06/16/21	DOMESTIC UNIFORM RENTALS	BUILDING SUPPLIES/BOAT RAMP/06/16/2	0616210535	07/13/21	45.20	
594-597-931.000	06/04/21	MENARDS	MATS AND PAINT/HARBOR	78120	07/13/21	292.86	
594-597-931.000	06/30/21	DOMESTIC UNIFORM RENTALS	BUILDING SUPPLIES/BOAT RAMP/06/30/2	0630210535	07/13/21	45.20	
594-597-931.000	06/30/21	DOMESTIC UNIFORM RENTALS	BUILDING SUPPLIES/MARINA/06/30/21	0630210515	07/13/21	74.47	
594-597-931.000	06/30/21	DOMESTIC UNIFORM RENTALS	CASES OF JUMBO TOILET TISSUE/MARINA	06/22/21	07/13/21	174.88	
594-597-932.000	05/01/21	ELAN CORP. PAYMENT SYSTEMS	ELAN CREDIT CARD	4715110310872797	07/13/21	290.28	5043
594-597-932.000	06/27/21	NEW BUFFALO HARDWARE	GROUNDS REPAIR/HARB	B76240	07/13/21	17.99	
594-597-932.000	05/31/21	MID CITY SUPPLY CO INC	GROUNDS REPAIR/BOAT RAMP/BOAT LAUNC	18612	07/13/21	455.79	
594-597-932.000	06/04/21	CLEAN EARTH ENVIRONMENTAL SRV	VACCUM AND CLENA STORM DRAINS/BOAT	333462	07/13/21	2,626.40	
594-597-932.000	06/14/21	VERSAW EARTHWORKS LLC	SECOND LOAD TOPSOIL/MARINA/HARB	1348	07/13/21	375.00	
594-597-932.000	07/07/21	D'AMICO KRISTEN	REIMB FOR LIGHTING FOR MARINA	070921	07/13/21	125.06	
594-597-932.000	06/30/21	EMC-ELECTRICAL MAINTENANCE & (REPAIR WIRES/MARINA	8185	07/13/21	150.00	
594-597-932.000	06/30/21	NEW BUFFALO HARDWARE	GROUNDS REPAIR/HARB	A197808	07/13/21	10.99	
594-597-932.000	07/08/21	MARINA ELECTRICAL EQUIPMENT, I	POWER PEDESTALS FOR MARINA	61280	07/13/21	2,876.00	
Total For Dept 597 HARBOR OPERATIONS						26,419.12	
Total For Fund 594 HARBOR OPERATIONS						26,419.12	
Fund 703 CURRENT TAX FUND							
Dept 000							
703-000-214.000	07/02/21	NEW BUFFALO LIBRARY JOINT BLDG	2020 REVOLVING TAX FUND SETTLEMENT	062921	07/02/21	4,423.87	2242
703-000-214.000	07/02/21	NEW BUFFALO PUBLIC LIBRARY	2020 REVOLVING TAX FUND SETTLEMENT	062921	07/13/21	4,222.70	2243
703-000-230.100	07/13/21	BERRIEN COUNTY TREASURER	COUNTY SET 7/1 THRU 7/12	071321	07/13/21	108,191.85	2244

INVOICE GL DISTRIBUTION REPORT
 POST DATES 06/10/2021 - 07/13/2021
 BOTH JOURNALIZED AND UNJOURNALIZED
 BOTH OPEN AND PAID

GL Number	Invoice Date	Vendor	Invoice Desc.	Invoice	Due Date	Amount	check #
Fund 703 CURRENT TAX FUND							
Dept 000							
703-000-230.100	07/13/21	BERRIEN COUNTY TREASURER	COUNTY GENERAL 7/1 THRU 7/12	071321 GEN	07/13/21	85,976.05	2244
703-000-230.200	07/02/21	NEW BUFFALO AREA SCHOOLS	WINTER: SCHOOL OP PLUS PENALTY FINA	062921	07/13/21	30,527.92	2241
703-000-230.200	07/13/21	NEW BUFFALO AREA SCHOOLS	SUMMER: SCHOOL OP 7/1 THRU 7/12	071321	07/13/21	118,261.71	2245
703-000-230.300	06/29/21	LAKE MICHIGAN COLLEGE	LMC TAX COLLECTION FINAL DISBURSEM	062921	07/13/21	12,598.25	2240
703-000-230.400	06/29/21	NEW BUFFALO LIBRARY JOINT BLDG	LIBRARY BOND FINAL DISBURSEMENT	062821	07/13/21	1,946.20	2242
703-000-230.400	07/02/21	NEW BUFFALO PUBLIC LIBRARY	LIBRARY TAXES COLLECTED FINAL DISBU	062821	07/13/21	1,857.74	2243
703-000-230.500	06/29/21	BERRIEN RESA	RESA GEN & SPEC ED TAXES FINAL DISB	062921	07/13/21	13,179.01	2239
Total For Dept 000						381,185.30	
Total For Fund 703 CURRENT TAX FUND						381,185.30	

INVOICE GL DISTRIBUTION REPORT
 POST DATES 06/10/2021 - 07/13/2021
 BOTH JOURNALIZED AND UNJOURNALIZED
 BOTH OPEN AND PAID

GL Number	Invoice Date	Vendor	Invoice Desc.	Invoice	Due Date	Amount	check #
Fund Totals:			Fund 101 GENERAL FUND			179,439.54	
			Fund 208 PARK FUND			18,909.55	
			Fund 402 EQUIPMENT PURCHASE FUND			51,691.58	
			Fund 590 SEWER FUND			306.09	
			Fund 591 WATER FUND			39,387.92	
			Fund 594 HARBOR OPERATIONS			26,419.12	
			Fund 703 CURRENT TAX FUND			381,185.30	
			Total For All Funds:			<u>697,339.10</u>	

REVENUE AND EXPENDITURE REPORT FOR CITY OF NEW BUFFALO

PERIOD ENDING 06/30/2021

% Fiscal Year Completed: 100.00

*NOTE: Available Balance / Pct Budget Used does not reflect amounts encumbered.

GL NUMBER	DESCRIPTION	2020-21		YTD BALANCE 06/30/2021	END BALANCE 06/30/2020	ACTIVITY FOR MONTH 06/30/21	AVAILABLE BALANCE	% BDGT USED
		ORIGINAL BUDGET	2020-21 AMENDED BUDGET					
Fund 101 - GENERAL FUND								
Revenues								
101-000-404.000	PROPERTY TAXES	2,501,055.00	2,501,055.00	2,501,055.00	2,438,063.29	0.00	0.00	100.00
101-000-417.000	DELINQUENT TAX PERSONAL	0.00	0.00	0.00	1.02	0.00	0.00	0.00
101-000-445.000	PENALTY & INTEREST	7,000.00	7,000.00	10,653.53	8,432.67	982.24	(3,653.53)	152.19
101-000-477.000	BUILDING PERMITS	35,000.00	35,000.00	62,874.92	29,357.41	8,358.00	(27,874.92)	179.64
101-000-478.000	ELECTRICAL PERMITS	10,000.00	10,000.00	23,693.80	9,959.90	3,006.45	(13,693.80)	236.94
101-000-479.000	MECHANICAL PERMITS	10,000.00	10,000.00	23,490.91	9,836.70	1,265.00	(13,490.91)	234.91
101-000-480.000	PLUMBING PERMITS	6,500.00	6,500.00	13,988.74	4,747.60	1,749.30	(7,488.74)	215.21
101-000-481.000	ZONING DEPOSITS	500.00	500.00	850.00	0.00	0.00	(350.00)	170.00
101-000-482.000	MISC LICENSES & PERMITS	0.00	0.00	601.00	0.00	301.00	(601.00)	100.00
101-000-528.000	OTHER FEDERAL GRANTS	0.00	0.00	82,655.45	0.00	0.00	(82,655.45)	100.00
101-000-573.000	LOCAL COMMUNITY STABILIZATION	5,000.00	5,000.00	17,199.42	5,637.97	11,561.45	(12,199.42)	343.99
101-000-574.000	CVTRS	10,095.00	10,095.00	11,880.00	9,900.00	1,980.00	(1,785.00)	117.68
101-000-576.000	STATE REVENUE SALES TAX	105,000.00	105,000.00	197,268.00	138,761.00	29,445.00	(92,268.00)	187.87
101-000-577.000	STATE REVENUE LIQUOR LICENSE	10,000.00	10,000.00	10,003.95	10,847.10	0.00	(3.95)	100.04
101-000-606.000	COURT CHARGES	1,000.00	1,000.00	224.75	521.83	0.00	775.25	22.48
101-000-615.000	SPECIAL USE FEE	1,600.00	1,600.00	2,010.00	991.50	602.00	(410.00)	125.63
101-000-617.000	FRANCHISE FEE	56,000.00	56,000.00	59,016.59	47,803.83	0.00	(3,016.59)	105.39
101-000-618.000	ADMINISTRATION FEE	95,000.00	95,000.00	101,934.74	101,278.18	7,111.64	(6,934.74)	107.30
101-000-619.000	VARIANCE FEE	2,500.00	2,500.00	4,350.00	3,100.00	0.00	(1,850.00)	174.00
101-000-627.000	SHORT TERM RENTAL FEES	30,000.00	30,000.00	70,275.00	49,225.00	2,775.00	(40,275.00)	234.25
101-000-628.000	SERVICE CHARGE	1,500.00	1,500.00	73.71	180.00	0.00	1,426.29	4.91
101-000-629.000	WASTE	272,834.00	272,834.00	269,655.88	268,023.59	26,555.57	3,178.12	98.84
101-000-629.100	PENALTY WASTE	3,000.00	3,000.00	2,999.47	3,176.82	176.20	0.53	99.98
101-000-654.100	OVERNIGHT PARKING PERMITS	20.00	20.00	0.00	7.00	0.00	20.00	0.00
101-000-656.000	TOWING SERVICE	1,500.00	1,500.00	0.00	1,950.00	0.00	1,500.00	0.00
101-000-657.000	PARKING FINES	500.00	500.00	87.00	224.00	(51.00)	413.00	17.40
101-000-665.000	INTEREST EARNED	6,000.00	6,000.00	1,886.13	12,117.24	0.66	4,113.87	31.44
101-000-670.000	RENTAL/LEASE	1,000.00	1,000.00	0.00	400.00	0.00	1,000.00	0.00
101-000-673.000	SALE OF ASSETS	0.00	0.00	58,182.00	10.00	0.00	(58,182.00)	100.00
101-000-675.000	DONATIONS	500.00	500.00	0.00	50.00	0.00	500.00	0.00
101-000-678.000	REIMBURSEMENTS	20,000.00	20,000.00	24,200.20	36,433.48	13,075.96	(4,200.20)	121.00
101-000-678.200	REIMBURSEMENTS-POLICE	73,341.00	73,341.00	81,749.03	63,728.47	29,383.39	(8,408.03)	111.46
TOTAL REVENUES		3,266,445.00	3,266,445.00	3,632,859.22	3,254,765.60	138,277.86	(366,414.22)	111.22
Expenditures								
101-101-703.000	SALARIES APPOINTED	11,500.00	11,500.00	10,545.04	11,926.25	2,561.25	954.96	91.70
101-101-714.000	MEDICARE	200.00	200.00	152.89	172.92	37.13	47.11	76.45
101-101-720.000	WORKER'S COMPENSATION INS	65.00	65.00	183.84	47.04	0.00	(118.84)	282.83
101-101-721.000	UNEMPLOYMENT COMPENSATION	550.00	550.00	165.15	297.18	0.00	384.85	30.03
101-101-756.000	OPERATING SUPPLIES	1,500.00	1,500.00	28.00	0.00	0.00	1,472.00	1.87
101-101-801.000	EDUCATION & TRAINING	0.00	0.00	195.00	0.00	0.00	(195.00)	100.00
101-101-818.000	PROFESSIONAL & CONTRACTUAL	500.00	500.00	0.00	0.00	0.00	500.00	0.00
101-101-826.000	LEGAL	0.00	0.00	0.00	0.00	0.00	0.00	0.00
101-101-831.000	MEMBERSHIPS & DUES	100.00	100.00	0.00	85.00	0.00	100.00	0.00
101-101-885.000	PUBLIC RELATIONS	0.00	0.00	0.00	0.00	0.00	0.00	0.00
101-101-903.000	PRINTING & PUBLISHING	250.00	250.00	402.00	548.00	0.00	(152.00)	160.80
101-101-962.000	MISCELLANEOUS	0.00	0.00	0.00	0.00	0.00	0.00	0.00
101-172-703.000	SALARIES APPOINTED	47,741.00	47,741.00	39,353.72	42,213.29	4,609.59	8,387.28	82.43
101-172-706.000	SALARIES PERMANENT	0.00	0.00	0.00	0.00	0.00	0.00	0.00
101-172-712.000	CASH IN LIEU OF PAYMENTS	10,200.00	10,200.00	4,875.00	13,525.00	0.00	5,325.00	47.79
101-172-714.000	MEDICARE	742.00	742.00	630.55	840.16	63.73	111.45	84.98
101-172-715.000	SOCIAL SECURITY TAX	3,175.00	3,175.00	2,696.63	3,592.70	272.53	478.37	84.93

REVENUE AND EXPENDITURE REPORT FOR CITY OF NEW BUFFALO

PERIOD ENDING 06/30/2021

% Fiscal Year Completed: 100.00

*NOTE: Available Balance / Pct Budget Used does not reflect amounts encumbered.

GL NUMBER	DESCRIPTION	2020-21		YTD BALANCE 06/30/2021	END BALANCE 06/30/2020	ACTIVITY FOR MONTH 06/30/21	AVAILABLE BALANCE	% BDGT USED
		ORIGINAL BUDGET	2020-21 AMENDED BUDGET					
Fund 101 - GENERAL FUND								
Expenditures								
101-172-716.000	HEALTH INSURANCE	0.00	0.00	4,857.03	0.00	1,214.26	(4,857.03)	100.00
101-172-717.000	LIFE & DISABILITY INSURANCE	2,800.00	2,800.00	1,838.55	2,190.12	195.96	961.45	65.66
101-172-718.000	RETIREMENT	7,200.00	7,200.00	4,885.48	7,483.50	523.08	2,314.52	67.85
101-172-720.000	WORKER'S COMPENSATION INS	750.00	750.00	500.98	602.67	0.00	249.02	66.80
101-172-721.000	UNEMPLOYMENT COMPENSATION	800.00	800.00	0.00	189.00	0.00	800.00	0.00
101-172-728.000	OFFICE SUPPLIES	200.00	200.00	975.52	184.24	0.00	(775.52)	487.76
101-172-756.000	OPERATING SUPPLIES	300.00	300.00	1,246.98	47.05	0.00	(946.98)	415.66
101-172-801.000	EDUCATION & TRAINING	1,500.00	1,500.00	0.00	539.18	0.00	1,500.00	0.00
101-172-818.000	PROFESSIONAL & CONTRACTUAL	2,000.00	2,000.00	1,311.00	0.00	0.00	689.00	65.55
101-172-831.000	MEMBERSHIPS & DUES	0.00	0.00	0.00	0.00	0.00	0.00	0.00
101-172-853.000	TELEPHONE	0.00	0.00	182.57	0.00	0.00	(182.57)	100.00
101-172-873.000	TRAVEL/MILEAGE REIMB	0.00	0.00	0.00	0.00	0.00	0.00	0.00
101-172-903.000	PRINTING & PUBLISHING	100.00	100.00	221.27	0.00	0.00	(121.27)	221.27
101-172-934.000	OTHER REPAIRS & MAINT	200.00	4,300.00	4,248.68	0.00	0.00	51.32	98.81
101-172-962.000	MISCELLANEOUS	0.00	0.00	0.00	0.00	0.00	0.00	0.00
101-215-703.000	SALARIES APPOINTED	63,280.00	63,280.00	45,514.61	49,224.76	5,224.05	17,765.39	71.93
101-215-706.000	SALARIES PERMANENT	35,000.00	40,500.00	41,097.83	31,411.61	4,632.00	(597.83)	101.48
101-215-706.100	SALARIES-OVERTIME	5,000.00	6,500.00	6,425.15	0.00	0.00	74.85	98.85
101-215-714.000	MEDICARE	1,344.00	1,344.00	1,285.51	1,138.15	134.87	58.49	95.65
101-215-715.000	SOCIAL SECURITY TAX	6,040.00	6,040.00	5,496.64	4,866.68	576.66	543.36	91.00
101-215-716.000	HEALTH INSURANCE	31,186.00	31,186.00	18,554.25	19,263.20	1,480.02	12,631.75	59.50
101-215-717.000	LIFE & DISABILITY INSURANCE	1,874.00	1,874.00	2,571.93	1,560.78	284.89	(697.93)	137.24
101-215-718.000	RETIREMENT	5,222.00	5,222.00	6,803.06	6,029.08	525.66	(1,581.06)	130.28
101-215-720.000	WORKER'S COMPENSATION INS	550.00	550.00	354.68	390.30	0.00	195.32	64.49
101-215-721.000	UNEMPLOYMENT COMPENSATION	1,200.00	1,200.00	399.00	545.19	0.00	801.00	33.25
101-215-722.000	MEDICAL EXPENSE	0.00	0.00	60.00	0.00	0.00	(60.00)	100.00
101-215-728.000	OFFICE SUPPLIES	350.00	350.00	0.00	431.48	0.00	350.00	0.00
101-215-751.000	GASOLINE	100.00	100.00	216.16	277.76	216.16	(116.16)	216.16
101-215-756.000	OPERATING SUPPLIES	200.00	200.00	372.83	128.60	0.00	(172.83)	186.42
101-215-801.000	EDUCATION & TRAINING	250.00	250.00	892.50	1,300.00	0.00	(642.50)	357.00
101-215-818.000	PROFESSIONAL & CONTRACTUAL	500.00	500.00	819.00	673.93	0.00	(319.00)	163.80
101-215-831.000	MEMBERSHIPS & DUES	300.00	300.00	175.00	262.86	0.00	125.00	58.33
101-215-903.000	PRINTING & PUBLISHING	600.00	600.00	0.00	146.00	0.00	600.00	0.00
101-215-934.000	OTHER REPAIRS & MAINT	300.00	300.00	0.00	0.00	0.00	300.00	0.00
101-215-942.000	EQUIPMENT	0.00	0.00	0.00	1,320.53	0.00	0.00	0.00
101-215-962.000	MISCELLANEOUS	0.00	0.00	13.24	0.00	13.24	(13.24)	100.00
101-247-818.000	PROFESSIONAL & CONTRACTUAL	2,000.00	2,000.00	1,279.00	360.00	0.00	721.00	63.95
101-247-962.000	MISCELLANEOUS	0.00	0.00	0.00	0.00	0.00	0.00	0.00
101-253-703.000	SALARIES APPOINTED	46,995.00	46,995.00	49,540.09	45,292.46	5,555.78	(2,545.09)	105.42
101-253-706.000	SALARIES PERMANENT	29,615.00	42,000.00	39,171.35	33,797.53	4,051.61	2,828.65	93.27
101-253-706.100	SALARIES-OVERTIME	600.00	3,500.00	2,334.15	245.02	87.35	1,165.85	66.69
101-253-714.000	MEDICARE	1,226.00	1,226.00	1,281.29	1,153.02	135.66	(55.29)	104.51
101-253-715.000	SOCIAL SECURITY TAX	4,164.00	4,164.00	5,478.72	4,929.84	580.08	(1,314.72)	131.57
101-253-716.000	HEALTH INSURANCE	16,500.00	16,500.00	16,227.18	14,580.93	1,290.04	272.82	98.35
101-253-717.000	LIFE & DISABILITY INSURANCE	3,823.00	3,823.00	4,288.91	3,893.88	355.67	(465.91)	112.19
101-253-718.000	RETIREMENT	9,522.00	9,522.00	9,798.32	9,449.33	754.56	(276.32)	102.90
101-253-720.000	WORKER'S COMPENSATION INS	550.00	550.00	354.68	390.30	0.00	195.32	64.49
101-253-721.000	UNEMPLOYMENT COMPENSATION	1,200.00	1,200.00	510.02	533.49	0.00	689.98	42.50
101-253-728.000	OFFICE SUPPLIES	250.00	250.00	169.04	74.97	0.00	80.96	67.62
101-253-730.000	POSTAGE	2,000.00	2,000.00	938.22	115.26	0.00	1,061.78	46.91
101-253-751.000	GASOLINE	375.00	375.00	33.71	357.62	0.00	341.29	8.99
101-253-756.000	OPERATING SUPPLIES	250.00	4,200.00	5,153.70	474.55	1,457.89	(953.70)	122.71
101-253-801.000	EDUCATION & TRAINING	1,200.00	1,200.00	(150.00)	1,274.30	0.00	1,350.00	(12.50)
101-253-818.000	PROFESSIONAL & CONTRACTUAL	8,500.00	8,500.00	6,353.75	6,202.67	2,437.50	2,146.25	74.75

REVENUE AND EXPENDITURE REPORT FOR CITY OF NEW BUFFALO

PERIOD ENDING 06/30/2021

% Fiscal Year Completed: 100.00

*NOTE: Available Balance / Pct Budget Used does not reflect amounts encumbered.

GL NUMBER	DESCRIPTION	2020-21		YTD BALANCE 06/30/2021	END BALANCE 06/30/2020	ACTIVITY FOR MONTH 06/30/21	AVAILABLE BALANCE	% BGD USED
		ORIGINAL BUDGET	2020-21 AMENDED BUDGET					
Fund 101 - GENERAL FUND								
Expenditures								
101-253-831.000	MEMBERSHIPS & DUES	300.00	300.00	295.50	364.00	0.00	4.50	98.50
101-253-853.000	PHONE BILLS & STIPENDS	0.00	0.00	550.00	0.00	0.00	(550.00)	100.00
101-253-903.000	PRINTING & PUBLISHING	600.00	600.00	1,657.35	274.00	0.00	(1,057.35)	276.23
101-253-934.000	OTHER REPAIRS & MAINT	150.00	150.00	0.00	470.67	0.00	150.00	0.00
101-253-962.000	MISCELLANEOUS	0.00	0.00	0.00	0.00	0.00	0.00	0.00
101-257-707.000	SALARIES PART-TIME	0.00	0.00	0.00	0.00	0.00	0.00	0.00
101-257-714.000	MEDICARE	0.00	0.00	0.00	0.00	0.00	0.00	0.00
101-257-715.000	SOCIAL SECURITY TAX	0.00	0.00	0.00	0.00	0.00	0.00	0.00
101-257-720.000	WORKER'S COMPENSATION INS	0.00	0.00	0.00	0.00	0.00	0.00	0.00
101-257-721.000	UNEMPLOYMENT COMPENSATION	0.00	0.00	0.00	0.00	0.00	0.00	0.00
101-257-728.000	OFFICE SUPPLIES	125.00	125.00	0.00	43.45	0.00	125.00	0.00
101-257-730.000	POSTAGE	2,300.00	2,300.00	1,910.43	2,216.35	0.00	389.57	83.06
101-257-756.000	OPERATING SUPPLIES	100.00	100.00	0.00	1,195.64	0.00	100.00	0.00
101-257-801.000	EDUCATION & TRAINING	0.00	0.00	0.00	0.00	0.00	0.00	0.00
101-257-818.000	PROFESSIONAL & CONTRACTUAL	24,960.00	46,460.00	29,127.50	27,587.50	4,285.00	17,332.50	62.69
101-257-831.000	MEMBERSHIPS & DUES	0.00	0.00	0.00	0.00	0.00	0.00	0.00
101-257-854.200	SOFTWARE EXPENSE	900.00	900.00	0.00	0.00	0.00	900.00	0.00
101-257-903.000	PRINTING & PUBLISHING	100.00	100.00	0.00	516.00	0.00	100.00	0.00
101-257-934.000	OTHER REPAIRS & MAINT	100.00	100.00	0.00	166.00	0.00	100.00	0.00
101-257-962.000	MISCELLANEOUS	0.00	0.00	0.00	0.00	0.00	0.00	0.00
101-262-703.000	SALARIES APPOINTED	2,000.00	2,000.00	2,000.00	2,000.05	0.00	0.00	100.00
101-262-714.000	MEDICARE	30.00	30.00	29.00	29.00	0.00	1.00	96.67
101-262-715.000	SOCIAL SECURITY TAX	110.00	110.00	124.00	124.01	0.00	(14.00)	112.73
101-262-730.000	POSTAGE	500.00	500.00	200.00	200.00	0.00	300.00	40.00
101-262-751.000	GASOLINE	250.00	250.00	0.00	153.52	0.00	250.00	0.00
101-262-756.000	OPERATING SUPPLIES	1,500.00	1,500.00	846.72	2,454.80	0.00	653.28	56.45
101-262-801.000	EDUCATION & TRAINING	200.00	200.00	0.00	0.00	0.00	200.00	0.00
101-262-818.000	PROFESSIONAL & CONTRACTUAL	6,000.00	6,000.00	5,555.45	2,916.50	0.00	444.55	92.59
101-262-903.000	PRINTING & PUBLISHING	700.00	3,000.00	2,902.08	816.10	0.00	97.92	96.74
101-262-934.000	OTHER REPAIRS & MAINT	400.00	400.00	440.00	0.00	0.00	(40.00)	110.00
101-262-962.000	MISCELLANEOUS	0.00	0.00	0.00	0.00	0.00	0.00	0.00
101-266-826.100	LABOR MATTERS	5,000.00	5,000.00	540.00	8,440.50	0.00	4,460.00	10.80
101-266-826.300	COURT/ORDINANCE	15,000.00	15,000.00	16,807.87	9,384.00	831.00	(1,807.87)	112.05
101-266-826.400	OTHER LEGAL MATTERS	40,000.00	40,000.00	25,243.50	36,484.38	0.00	14,756.50	63.11
101-266-826.500	FOIA	5,000.00	5,000.00	0.00	0.00	0.00	5,000.00	0.00
101-276-969.000	CONTRIBUTIONS TO OTHERS	30,000.00	30,000.00	30,000.00	29,500.00	0.00	0.00	100.00
101-298-706.000	SALARIES PERMANENT	67,060.00	67,060.00	65,693.21	63,250.81	6,754.20	1,366.79	97.96
101-298-706.100	SALARIES-OVERTIME	0.00	0.00	81.51	0.00	18.81	(81.51)	100.00
101-298-707.000	SALARIES PART-TIME	0.00	0.00	75.95	0.00	56.26	(75.95)	100.00
101-298-714.000	MEDICARE	1,018.00	1,018.00	837.58	861.08	88.63	180.42	82.28
101-298-715.000	SOCIAL SECURITY TAX	4,354.00	4,354.00	3,581.34	3,681.81	378.96	772.66	82.25
101-298-716.000	HEALTH INSURANCE	35,740.00	35,740.00	36,029.48	24,426.94	90.12	(289.48)	100.81
101-298-717.000	LIFE & DISABILITY INSURANCE	1,280.00	1,280.00	2,761.26	1,886.28	227.10	(1,481.26)	215.72
101-298-718.000	RETIREMENT	5,618.00	5,618.00	4,956.01	4,980.50	214.02	661.99	88.22
101-298-720.000	WORKER'S COMPENSATION INS	1,500.00	1,500.00	838.56	1,100.91	0.00	661.44	55.90
101-298-721.000	UNEMPLOYMENT COMPENSATION	1,000.00	1,000.00	330.65	466.41	0.00	669.35	33.07
101-298-728.000	OFFICE SUPPLIES	4,000.00	7,000.00	7,891.33	3,606.16	75.98	(891.33)	112.73
101-298-730.000	POSTAGE	4,700.00	4,700.00	4,668.02	4,317.19	1,020.99	31.98	99.32
101-298-751.000	GASOLINE	600.00	600.00	295.27	203.04	230.19	304.73	49.21
101-298-756.000	OPERATING SUPPLIES	3,500.00	3,500.00	3,633.64	2,282.80	18.98	(133.64)	103.82
101-298-818.000	PROFESSIONAL & CONTRACTUAL	7,000.00	7,000.00	4,746.95	7,344.34	52.74	2,253.05	67.81
101-298-818.200	ENGINEERING	20,000.00	20,000.00	25,467.00	19,500.00	4,840.50	(5,467.00)	127.34
101-298-831.000	MEMBERSHIPS & DUES	2,500.00	2,500.00	1,989.74	2,310.50	0.00	510.26	79.59
101-298-853.000	TELEPHONE	0.00	0.00	31.18	0.00	31.18	(31.18)	100.00

REVENUE AND EXPENDITURE REPORT FOR CITY OF NEW BUFFALO

PERIOD ENDING 06/30/2021

% Fiscal Year Completed: 100.00

*NOTE: Available Balance / Pct Budget Used does not reflect amounts encumbered.

GL NUMBER	DESCRIPTION	2020-21		YTD BALANCE 06/30/2021	END BALANCE 06/30/2020	ACTIVITY FOR MONTH 06/30/21	AVAILABLE BALANCE	% BDGT USED
		ORIGINAL BUDGET	2020-21 AMENDED BUDGET					
Fund 101 - GENERAL FUND								
Expenditures								
101-298-854.000	TECH SUPPORT/MAINTENANCE	27,000.00	27,000.00	22,581.64	30,302.16	3,425.00	4,418.36	83.64
101-298-854.100	WEBSITE/SOCIAL MEDIA	7,300.00	7,300.00	4,611.17	5,768.54	0.00	2,688.83	63.17
101-298-854.200	SOFTWARE EXPENSE	20,000.00	20,000.00	24,409.61	17,314.59	133.86	(4,409.61)	122.05
101-298-854.300	IT HARDWARE & EQUIPMENT	0.00	6,000.00	2,469.05	0.00	0.00	3,530.95	41.15
101-298-903.000	PRINTING & PUBLISHING	6,000.00	6,000.00	5,623.88	6,913.98	2,155.41	376.12	93.73
101-298-920.000	UTILITIES	14,000.00	14,000.00	10,730.62	10,803.51	750.95	3,269.38	76.65
101-298-931.000	BUILDING REPAIR & MAINTENANCE	25,000.00	25,000.00	18,329.25	24,841.28	1,029.11	6,670.75	73.32
101-298-932.000	GROUNDING REPAIR & MAINT	4,500.00	4,500.00	2,560.32	3,077.65	0.00	1,939.68	56.90
101-298-934.000	OTHER REPAIRS & MAINT	5,000.00	5,000.00	0.00	1,461.33	0.00	5,000.00	0.00
101-298-939.000	VEHICLE REPAIR & MAINTENANCE	0.00	0.00	0.00	110.02	0.00	0.00	0.00
101-298-942.000	EQUIPMENT	1,500.00	1,500.00	787.45	2,555.83	0.00	712.55	52.50
101-298-943.000	EQUIPMENT RENTAL	12,500.00	12,500.00	6,452.23	5,972.99	603.19	6,047.77	51.62
101-298-956.200	REFUNDS	3,500.00	3,500.00	735.85	39.89	0.00	2,764.15	21.02
101-298-962.000	MISCELLANEOUS	0.00	0.00	12,041.64	11,009.53	12,015.89	(12,041.64)	100.00
101-298-971.000	CASH SHORT/OVER	0.00	0.00	0.00	0.00	0.00	0.00	0.00
101-305-705.000	SALARIES SUPERVISION	82,792.00	82,792.00	89,262.55	57,242.35	9,552.84	(6,470.55)	107.82
101-305-706.000	SALARIES PERMANENT	386,250.00	386,250.00	398,655.82	382,456.49	50,026.30	(12,405.82)	103.21
101-305-706.100	SALARIES-OVERTIME	60,000.00	60,000.00	48,575.17	54,635.52	5,317.85	11,424.83	80.96
101-305-706.400	SALARIES--PARKING ENF	0.00	0.00	1,173.75	0.00	1,173.75	(1,173.75)	100.00
101-305-707.000	SALARIES PART-TIME	58,000.00	58,000.00	55,753.64	57,742.56	11,080.15	2,246.36	96.13
101-305-714.000	MEDICARE	7,688.00	7,688.00	8,193.83	7,973.19	1,064.66	(505.83)	106.58
101-305-715.000	SOCIAL SECURITY TAX	32,875.00	32,875.00	35,035.67	34,092.40	4,552.27	(2,160.67)	106.57
101-305-716.000	HEALTH INSURANCE	142,000.00	142,000.00	115,341.58	103,947.48	6,575.09	26,658.42	81.23
101-305-717.000	LIFE & DISABILITY INSURANCE	14,218.00	14,218.00	14,834.64	11,761.56	1,377.48	(616.64)	104.34
101-305-718.000	RETIREMENT	37,384.00	37,384.00	35,110.49	32,398.72	2,945.45	2,273.51	93.92
101-305-720.000	WORKER'S COMPENSATION INS	14,000.00	14,000.00	6,963.18	11,127.75	0.00	7,036.82	49.74
101-305-721.000	UNEMPLOYMENT COMPENSATION	5,558.00	5,558.00	2,450.73	3,025.28	0.00	3,107.27	44.09
101-305-722.000	MEDICAL EXPENSE	1,600.00	1,600.00	7,995.80	1,263.61	196.00	(6,395.80)	499.74
101-305-728.000	OFFICE SUPPLIES	1,600.00	1,600.00	655.84	537.62	35.99	944.16	40.99
101-305-730.000	POSTAGE	150.00	150.00	26.65	72.95	0.00	123.35	17.77
101-305-751.000	GASOLINE	17,000.00	17,000.00	9,159.15	9,130.90	2,624.38	7,840.85	53.88
101-305-756.000	OPERATING SUPPLIES	2,100.00	2,100.00	1,770.65	1,894.55	0.00	329.35	84.32
101-305-767.000	EQUIPMENT/SMALL TOOLS	4,000.00	4,000.00	2,809.51	2,166.89	0.00	1,190.49	70.24
101-305-768.000	UNIFORMS	12,000.00	12,000.00	12,779.73	13,870.07	2,648.48	(779.73)	106.50
101-305-768.100	AMMO	4,500.00	4,500.00	2,762.80	2,641.02	1,180.00	1,737.20	61.40
101-305-768.200	UNIFORM ALLOW-RESERVE/CERT	1,600.00	1,600.00	388.13	424.59	0.00	1,211.87	24.26
101-305-769.000	K-9	0.00	0.00	0.00	0.00	0.00	0.00	0.00
101-305-801.000	EDUCATION & TRAINING	5,355.00	5,355.00	3,118.92	4,032.30	87.67	2,236.08	58.24
101-305-818.000	PROFESSIONAL & CONTRACTUAL	5,200.00	5,200.00	6,798.50	3,508.65	1,981.00	(1,598.50)	130.74
101-305-831.000	MEMBERSHIPS & DUES	600.00	600.00	874.00	619.64	0.00	(274.00)	145.67
101-305-851.000	RADIO/VIDEO MAINTENANCE	5,200.00	5,200.00	4,287.06	4,471.30	343.80	912.94	82.44
101-305-853.000	TELEPHONE	6,200.00	6,200.00	4,553.16	5,468.42	319.49	1,646.84	73.44
101-305-903.000	PRINTING & PUBLISHING	1,000.00	1,000.00	1,045.98	735.73	0.00	(45.98)	104.60
101-305-913.000	INSURANCE	11,000.00	11,000.00	8,585.72	7,189.43	1,705.75	2,414.28	78.05
101-305-916.000	LIABILITY INSURANCE	58,000.00	58,000.00	56,694.18	46,137.21	11,258.45	1,305.82	97.75
101-305-920.000	UTILITIES	10,000.00	10,000.00	10,236.41	9,848.64	722.92	(236.41)	102.36
101-305-931.000	BUILDING REPAIR & MAINTENANCE	9,000.00	9,000.00	3,229.84	12,709.08	477.11	5,770.16	35.89
101-305-933.000	EQUIPMENT & MAINTENANCE	2,500.00	2,500.00	6,602.61	7,945.61	132.00	(4,102.61)	264.10
101-305-933.100	EQUIPMENT MAINT--PARKING ENFOR	2,050.00	2,050.00	3,196.91	0.00	0.00	(1,146.91)	155.95
101-305-934.000	OTHER REPAIRS & MAINT	4,000.00	4,000.00	673.03	2,137.30	302.85	3,326.97	16.83
101-305-939.000	VEHICLE REPAIR & MAINTENANCE	11,000.00	11,000.00	5,470.28	15,537.44	1,844.63	5,529.72	49.73
101-305-943.000	EQUIPMENT RENTAL	300.00	300.00	969.09	1,230.32	101.72	(669.09)	323.03
101-305-962.000	MISCELLANEOUS	0.00	0.00	0.00	0.00	0.00	0.00	0.00
101-305-979.000	EQUIPMENT	27,000.00	27,000.00	22,781.72	25,931.71	0.00	4,218.28	84.38

REVENUE AND EXPENDITURE REPORT FOR CITY OF NEW BUFFALO

PERIOD ENDING 06/30/2021

% Fiscal Year Completed: 100.00

*NOTE: Available Balance / Pct Budget Used does not reflect amounts encumbered.

GL NUMBER	DESCRIPTION	2020-21		YTD BALANCE 06/30/2021	END BALANCE 06/30/2020	ACTIVITY FOR MONTH 06/30/21	AVAILABLE BALANCE	% BDGT USED
		ORIGINAL BUDGET	2020-21 AMENDED BUDGET					
Fund 101 - GENERAL FUND								
Expenditures								
101-371-983.000	VEHICLE LEASES	0.00	1,792.00	1,791.81	0.00	440.72	0.19	99.99
101-442-705.000	SALARIES SUPERVISION	35,000.00	35,000.00	32,090.64	32,859.76	3,221.92	2,909.36	91.69
101-442-706.000	SALARIES PERMANENT	59,272.00	59,272.00	40,334.18	32,344.05	5,245.46	18,937.82	68.05
101-442-706.100	SALARIES-OVERTIME	15,000.00	15,000.00	9,837.25	6,700.32	626.51	5,162.75	65.58
101-442-707.000	SALARIES PART-TIME	0.00	0.00	0.00	0.00	0.00	0.00	0.00
101-442-714.000	MEDICARE	1,401.00	1,401.00	1,129.32	1,028.62	125.14	271.68	80.61
101-442-715.000	SOCIAL SECURITY TAX	6,920.00	6,920.00	4,829.71	4,398.33	535.02	2,090.29	69.79
101-442-716.000	HEALTH INSURANCE	70,354.00	70,354.00	52,570.01	53,774.10	4,677.94	17,783.99	74.72
101-442-717.000	LIFE & DISABILITY INSURANCE	7,587.00	7,587.00	6,860.65	4,564.94	629.95	726.35	90.43
101-442-718.000	RETIREMENT	17,917.00	17,917.00	14,461.25	11,286.25	1,297.02	3,455.75	80.71
101-442-720.000	WORKER'S COMPENSATION INS	15,000.00	15,000.00	7,695.02	12,449.64	0.00	7,304.98	51.30
101-442-721.000	UNEMPLOYMENT COMPENSATION	3,000.00	3,000.00	798.77	859.03	0.00	2,201.23	26.63
101-442-723.000	STIPENDS	500.00	500.00	308.28	700.00	108.28	191.72	61.66
101-442-728.000	OFFICE SUPPLIES	575.00	575.00	271.88	801.33	0.00	303.12	47.28
101-442-751.000	GASOLINE	2,200.00	2,200.00	1,279.91	699.87	159.79	920.09	58.18
101-442-756.000	OPERATING SUPPLIES	7,500.00	7,500.00	7,269.68	7,109.40	448.72	230.32	96.93
101-442-767.000	EQUIPMENT/SMALL TOOLS	5,000.00	5,000.00	4,027.88	7,402.85	81.24	972.12	80.56
101-442-768.000	UNIFORMS	2,400.00	2,400.00	1,419.73	1,350.61	545.47	980.27	59.16
101-442-801.000	EDUCATION & TRAINING	500.00	500.00	0.00	0.00	0.00	500.00	0.00
101-442-818.000	PROFESSIONAL & CONTRACTUAL	7,000.00	7,000.00	8,194.50	14,050.77	0.00	(1,194.50)	117.06
101-442-818.120	TREE REMOVALS	15,000.00	30,000.00	29,025.00	8,250.00	1,600.00	975.00	96.75
101-442-831.000	MEMBERSHIPS & DUES	600.00	600.00	949.58	580.49	0.00	(349.58)	158.26
101-442-853.000	TELEPHONE	1,200.00	1,200.00	1,088.48	1,000.10	40.01	111.52	90.71
101-442-903.000	PRINTING & PUBLISHING	300.00	300.00	1,065.31	935.84	226.31	(765.31)	355.10
101-442-913.000	INSURANCE	5,000.00	5,000.00	5,104.82	4,612.14	1,040.00	(104.82)	102.10
101-442-920.000	UTILITIES	16,000.00	16,000.00	19,151.99	15,228.97	1,705.78	(3,151.99)	119.70
101-442-931.000	BUILDING REPAIR & MAINTENANCE	20,000.00	20,000.00	11,431.88	25,069.87	265.09	8,568.12	57.16
101-442-932.000	GROUNDS REPAIR & MAINT	20,000.00	20,000.00	14,272.81	14,336.03	2,207.50	5,727.19	71.36
101-442-933.000	EQUIPMENT & MAINTENANCE	5,000.00	5,000.00	14,684.35	5,241.50	4,116.10	(9,684.35)	293.69
101-442-935.100	STORM SEWER REPAIR & MAINT	10,000.00	60,000.00	44,103.75	1,805.00	8,715.25	15,896.25	73.51
101-442-939.000	VEHICLE REPAIR & MAINTENANCE	12,000.00	12,000.00	10,640.21	14,053.88	1,369.63	1,359.79	88.67
101-442-943.000	EQUIPMENT RENTAL	3,000.00	3,000.00	1,972.35	20,970.73	0.00	1,027.65	65.75
101-442-962.000	MISCELLANEOUS	0.00	0.00	(167.42)	0.00	16.07	167.42	100.00
101-442-962.200	MISC PROJECT COSTS	0.00	0.00	0.00	0.00	0.00	0.00	0.00
101-442-974.000	CAPITAL IMPROVEMENTS	0.00	0.00	0.00	0.00	0.00	0.00	0.00
101-442-983.000	VEHICLE LEASES	0.00	0.00	0.00	0.00	0.00	0.00	0.00
101-448-926.000	STREET LIGHTING	37,000.00	37,000.00	21,849.58	33,402.76	3,740.06	15,150.42	59.05
101-523-818.000	PROFESSIONAL & CONTRACTUAL	272,256.00	272,256.00	276,259.70	229,868.60	22,147.28	(4,003.70)	101.47
101-523-956.200	REFUNDS	0.00	0.00	0.00	0.00	0.00	0.00	0.00
101-651-818.000	PROFESSIONAL & CONTRACTUAL	110,817.00	110,817.00	109,237.68	106,056.00	9,283.42	1,579.32	98.57
101-721-801.000	EDUCATION & TRAINING	1,400.00	1,400.00	0.00	0.00	0.00	1,400.00	0.00
101-721-818.000	PROFESSIONAL & CONTRACTUAL	3,000.00	3,000.00	447.00	578.00	0.00	2,553.00	14.90
101-721-831.000	MEMBERSHIPS & DUES	0.00	0.00	0.00	0.00	0.00	0.00	0.00
101-721-903.000	PRINTING & PUBLISHING	200.00	200.00	150.00	676.00	0.00	50.00	75.00
101-721-962.000	MISCELLANEOUS	0.00	0.00	0.00	0.00	0.00	0.00	0.00
101-722-818.000	PROFESSIONAL & CONTRACTUAL	700.00	12,000.00	3,766.00	324.00	0.00	8,234.00	31.38
101-722-831.000	MEMBERSHIPS & DUES	0.00	0.00	0.00	0.00	0.00	0.00	0.00
101-722-903.000	PRINTING & PUBLISHING	200.00	200.00	472.82	994.00	0.00	(272.82)	236.41
101-722-962.000	MISCELLANEOUS	0.00	0.00	0.00	0.00	0.00	0.00	0.00
101-872-807.000	AUDIT	3,000.00	3,000.00	3,000.00	3,000.00	0.00	0.00	100.00
101-872-818.000	PROFESSIONAL & CONTRACTUAL	20,000.00	20,000.00	14,960.35	19,056.00	0.00	5,039.65	74.80
101-872-818.200	ENGINEERING	6,000.00	6,000.00	4,800.00	0.00	0.00	1,200.00	80.00
101-872-854.000	TECH SUPPORT/MAINTENANCE	0.00	0.00	0.00	0.00	0.00	0.00	0.00
101-872-881.000	MISCELLANEOUS PROJECT COST	15,000.00	15,000.00	6,799.38	7,030.47	0.00	8,200.62	45.33

REVENUE AND EXPENDITURE REPORT FOR CITY OF NEW BUFFALO

PERIOD ENDING 06/30/2021

% Fiscal Year Completed: 100.00

*NOTE: Available Balance / Pct Budget Used does not reflect amounts encumbered.

GL NUMBER	DESCRIPTION	2020-21		YTD BALANCE 06/30/2021	END BALANCE 06/30/2020	ACTIVITY FOR MONTH 06/30/21	AVAILABLE BALANCE	% BDGT USED
		ORIGINAL BUDGET	2020-21 AMENDED BUDGET					
Fund 101 - GENERAL FUND								
Expenditures								
101-872-912.000	FIRE INSURANCE	5,000.00	5,000.00	4,781.07	4,296.76	919.77	218.93	95.62
101-872-913.000	INSURANCE	0.00	0.00	0.00	0.00	0.00	0.00	0.00
101-872-916.000	LIABILITY INSURANCE	9,000.00	9,000.00	8,070.24	6,752.43	1,605.56	929.76	89.67
101-872-932.500	AMTRAK PLATFORM MAINT.	800.00	800.00	0.00	0.00	0.00	800.00	0.00
101-872-962.000	MISCELLANEOUS	0.00	0.00	0.00	0.00	0.00	0.00	0.00
101-872-963.000	BANK FEES	7,000.00	7,000.00	5,427.96	8,267.97	50.00	1,572.04	77.54
101-965-898.000	TRANSFER TO PARK	75,000.00	75,000.00	75,000.00	110,000.00	0.00	0.00	100.00
101-965-980.000	TRANSFER TO EQUIP PURCHASE	30,000.00	30,000.00	30,000.00	29,000.00	0.00	0.00	100.00
101-965-995.594	TRANSFER TO HARBOR OPERATIONS	0.00	25,000.00	25,000.00	0.00	25,000.00	0.00	100.00
101-965-999.000	TRANSFERS OUT	0.00	0.00	0.00	0.00	0.00	0.00	0.00
101-965-999.130	TRANSFER TO DEBT SERVICE	127,543.00	127,543.00	127,543.00	128,313.00	0.00	0.00	100.00
TOTAL EXPENDITURES		3,218,952.00	3,459,532.00	3,107,200.26	2,820,490.07	345,153.57	352,331.74	89.82
Fund 101 - GENERAL FUND:								
TOTAL REVENUES		3,266,445.00	3,266,445.00	3,632,859.22	3,254,765.60	138,277.86	(366,414.22)	111.22
TOTAL EXPENDITURES		3,218,952.00	3,459,532.00	3,107,200.26	2,820,490.07	345,153.57	352,331.74	89.82
NET OF REVENUES & EXPENDITURES		47,493.00	(193,087.00)	525,658.96	434,275.53	(206,875.71)	(718,745.96)	272.24
BEG. FUND BALANCE		1,992,525.84	1,992,525.84	1,992,525.84	1,558,250.31			
END FUND BALANCE		2,040,018.84	1,799,438.84	2,518,184.80	1,992,525.84			
Fund 105 - PNBALRSB								
Revenues								
105-000-589.000	CONTRIBUTIONS	51,000.00	0.00	0.00	89,299.75	0.00	0.00	0.00
105-000-665.000	INTEREST EARNED	800.00	800.00	0.04	851.79	0.00	799.96	0.01
105-000-674.000	GRANTS	0.00	51,000.00	51,000.00	15,000.00	0.00	0.00	100.00
105-000-698.740	LRSB DISBURSEMENTS	215,000.00	215,000.00	220,879.80	290,673.54	0.00	(5,879.80)	102.73
TOTAL REVENUES		266,800.00	266,800.00	271,879.84	395,825.08	0.00	(5,079.84)	101.90
Expenditures								
105-000-807.000	AUDIT	3,920.00	3,920.00	3,920.00	3,920.00	0.00	0.00	100.00
105-442-976.100	N. WHITTAKER ST. REVDEVELOPMEN	0.00	0.00	0.00	0.00	0.00	0.00	0.00
105-670-818.000	PROFESSIONAL & CONTRACTUAL	20,000.00	60,000.00	56,750.00	106,305.00	0.00	3,250.00	94.58
105-670-818.200	ENGINEERING	20,000.00	20,000.00	2,000.00	56,218.16	0.00	18,000.00	10.00
105-670-881.110	CAPITAL PROJECTS	30,000.00	30,000.00	6,482.55	0.00	0.00	23,517.45	21.61
105-670-881.500	BUSINESS IMP DISTRICT PLAN	0.00	0.00	0.00	0.00	0.00	0.00	0.00
105-670-962.000	MISCELLANEOUS	0.00	0.00	0.00	0.00	0.00	0.00	0.00
105-670-970.000	CAPITAL IMPROVEMENTS	0.00	0.00	0.00	0.00	0.00	0.00	0.00
105-670-980.000	TRANSFER TO EQUIP PURCHASE	40,000.00	40,000.00	40,000.00	40,000.00	0.00	0.00	100.00
105-670-999.120	TRANSFER TO SEWER	0.00	0.00	0.00	0.00	0.00	0.00	0.00
105-670-999.150	TRANSFER TO DEBT SERVICE (MT)	0.00	0.00	0.00	51,063.00	0.00	0.00	0.00
105-670-999.200	TRANSFER TO MAJOR/LOCAL	0.00	0.00	0.00	300,000.00	0.00	0.00	0.00
105-670-999.300	TRANSFER TO GENERAL	0.00	0.00	0.00	0.00	0.00	0.00	0.00
TOTAL EXPENDITURES		113,920.00	153,920.00	109,152.55	557,506.16	0.00	44,767.45	70.92

REVENUE AND EXPENDITURE REPORT FOR CITY OF NEW BUFFALO

PERIOD ENDING 06/30/2021

% Fiscal Year Completed: 100.00

*NOTE: Available Balance / Pct Budget Used does not reflect amounts encumbered.

GL NUMBER	DESCRIPTION	2020-21		YTD BALANCE 06/30/2021	END BALANCE 06/30/2020	ACTIVITY FOR MONTH 06/30/21	AVAILABLE BALANCE	% BDGT USED
		ORIGINAL BUDGET	2020-21 AMENDED BUDGET					
Fund 105 - PNBALRSB								
Fund 105 - PNBALRSB:								
TOTAL REVENUES		266,800.00	266,800.00	271,879.84	395,825.08	0.00	(5,079.84)	101.90
TOTAL EXPENDITURES		113,920.00	153,920.00	109,152.55	557,506.16	0.00	44,767.45	70.92
NET OF REVENUES & EXPENDITURES		152,880.00	112,880.00	162,727.29	(161,681.08)	0.00	(49,847.29)	144.16
BEG. FUND BALANCE		491,247.63	491,247.63	491,247.63	652,928.71			
END FUND BALANCE		644,127.63	604,127.63	653,974.92	491,247.63			
Fund 202 - MAJOR STREET FUND								
Revenues								
202-000-546.000	MOTOR VEHICLE FUND TAX	145,000.00	145,000.00	239,022.40	208,676.70	38,091.78	(94,022.40)	164.84
202-000-566.000	OTHER STATE GRANTS (ACT 207)	0.00	0.00	0.00	0.00	0.00	0.00	0.00
202-000-665.000	INTEREST EARNED	1,200.00	1,200.00	172.06	3,026.64	9.89	1,027.94	14.34
202-000-699.100	TRANSFER IN	0.00	0.00	0.00	300,000.00	0.00	0.00	0.00
TOTAL REVENUES		146,200.00	146,200.00	239,194.46	511,703.34	38,101.67	(92,994.46)	163.61
Expenditures								
202-463-705.000	SALARIES SUPERVISION	3,750.00	3,750.00	6,151.63	756.64	644.42	(2,401.63)	164.04
202-463-706.000	SALARIES PERMANENT	17,000.00	17,000.00	22,852.34	16,501.38	3,059.86	(5,852.34)	134.43
202-463-714.000	MEDICARE	230.00	230.00	390.50	243.50	49.50	(160.50)	169.78
202-463-715.000	SOCIAL SECURITY TAX	1,100.00	1,100.00	1,669.71	1,040.96	211.61	(569.71)	151.79
202-463-751.000	GASOLINE	7,000.00	7,000.00	7,185.26	4,949.13	1,152.05	(185.26)	102.65
202-463-756.000	OPERATING SUPPLIES	8,500.00	8,500.00	1,009.00	3,741.89	0.00	7,491.00	11.87
202-463-767.000	EQUIPMENT/SMALL TOOLS	2,500.00	2,500.00	0.00	0.00	0.00	2,500.00	0.00
202-463-818.000	PROFESSIONAL & CONTRACTUAL	45,000.00	45,000.00	6,237.16	8,502.46	0.00	38,762.84	13.86
202-463-933.000	EQUIPMENT & MAINTENANCE	7,000.00	7,000.00	0.00	2,457.17	0.00	7,000.00	0.00
202-463-939.000	VEHICLE REPAIR & MAINTENANCE	5,000.00	5,000.00	983.50	0.00	0.00	4,016.50	19.67
202-463-962.100	TOOLS & EQUIP	2,500.00	2,500.00	0.00	0.00	0.00	2,500.00	0.00
202-474-705.000	SALARIES SUPERVISION	3,750.00	3,750.00	6,151.05	1,992.52	644.37	(2,401.05)	164.03
202-474-706.000	SALARIES PERMANENT	17,000.00	17,000.00	22,852.14	16,501.40	3,059.89	(5,852.14)	134.42
202-474-714.000	MEDICARE	230.00	230.00	390.36	243.46	49.47	(160.36)	169.72
202-474-715.000	SOCIAL SECURITY TAX	1,100.00	1,100.00	1,669.56	1,040.93	211.61	(569.56)	151.78
202-474-756.000	OPERATING SUPPLIES	3,000.00	3,000.00	1,961.53	3,942.19	0.00	1,038.47	65.38
202-474-767.000	EQUIPMENT/SMALL TOOLS	1,000.00	1,000.00	0.00	0.00	0.00	1,000.00	0.00
202-474-784.000	OPER SUPP SNOW & ICE	20,000.00	20,000.00	23,951.45	19,301.13	(1,195.25)	(3,951.45)	119.76
202-474-818.000	PROFESSIONAL & CONTRACTUAL	105,000.00	105,000.00	31,989.76	15,514.00	0.00	73,010.24	30.47
202-474-933.000	EQUIPMENT & MAINTENANCE	500.00	500.00	4,298.82	0.00	1,587.00	(3,798.82)	859.76
202-482-705.000	SALARIES SUPERVISION	4,500.00	4,500.00	3,675.73	4,725.59	490.35	824.27	81.68
202-482-714.000	MEDICARE	70.00	70.00	52.49	68.51	6.78	17.51	74.99
202-482-715.000	SOCIAL SECURITY TAX	300.00	300.00	224.57	293.00	28.98	75.43	74.86
202-482-807.000	AUDIT	1,000.00	1,000.00	1,000.00	1,000.00	0.00	0.00	100.00
202-482-962.000	MISCELLANEOUS	200.00	200.00	130.30	260.80	0.00	69.70	65.15
202-483-818.000	PROFESSIONAL & CONTRACTUAL	30,000.00	30,000.00	0.00	0.00	0.00	30,000.00	0.00
202-483-818.100	BRIDGE REHABILITATION	70,000.00	70,000.00	3,850.00	520,170.98	0.00	66,150.00	5.50
202-483-962.000	MISCELLANEOUS	0.00	0.00	0.00	0.00	0.00	0.00	0.00
TOTAL EXPENDITURES		357,230.00	357,230.00	148,676.86	623,247.64	10,000.64	208,553.14	41.62
Fund 202 - MAJOR STREET FUND:								
TOTAL REVENUES		146,200.00	146,200.00	239,194.46	511,703.34	38,101.67	(92,994.46)	163.61

REVENUE AND EXPENDITURE REPORT FOR CITY OF NEW BUFFALO

PERIOD ENDING 06/30/2021

% Fiscal Year Completed: 100.00

*NOTE: Available Balance / Pct Budget Used does not reflect amounts encumbered.

GL NUMBER	DESCRIPTION	2020-21		YTD BALANCE 06/30/2021	END BALANCE 06/30/2020	ACTIVITY FOR MONTH 06/30/21	AVAILABLE BALANCE	% BDGT USED
		ORIGINAL BUDGET	2020-21 AMENDED BUDGET					
Fund 202 - MAJOR STREET FUND								
TOTAL EXPENDITURES		357,230.00	357,230.00	148,676.86	623,247.64	10,000.64	208,553.14	41.62
NET OF REVENUES & EXPENDITURES		(211,030.00)	(211,030.00)	90,517.60	(111,544.30)	28,101.03	(301,547.60)	42.89
BEG. FUND BALANCE		319,176.59	319,176.59	319,176.59	430,720.89			
END FUND BALANCE		108,146.59	108,146.59	409,694.19	319,176.59			
Fund 203 - LOCAL STREET FUND								
Revenues								
203-000-546.000	MOTOR VEHICLE FUND TAX	60,000.00	60,000.00	120,929.31	105,652.34	19,269.63	(60,929.31)	201.55
203-000-566.000	OTHER STATE GRANTS (ACT 207)	10,000.00	10,000.00	0.00	0.00	0.00	10,000.00	0.00
203-000-578.000	STATE REVENUE METRO ACT	0.00	0.00	0.00	11,115.37	0.00	0.00	0.00
203-000-665.000	INTEREST EARNED	200.00	200.00	159.77	1,885.84	10.76	40.23	79.89
203-000-698.000	MISCELLANEOUS	0.00	0.00	0.00	0.00	0.00	0.00	0.00
203-000-699.400	TRANSFER FROM MAJOR STREET	0.00	0.00	0.00	0.00	0.00	0.00	0.00
TOTAL REVENUES		70,200.00	70,200.00	121,089.08	118,653.55	19,280.39	(50,889.08)	172.49
Expenditures								
203-463-705.000	SALARIES SUPERVISION	3,900.00	3,900.00	6,151.31	1,992.60	644.39	(2,251.31)	157.73
203-463-706.000	SALARIES PERMANENT	6,000.00	6,000.00	9,793.94	6,847.31	1,311.33	(3,793.94)	163.23
203-463-714.000	MEDICARE	135.00	135.00	217.20	120.39	26.38	(82.20)	160.89
203-463-715.000	SOCIAL SECURITY TAX	850.00	850.00	928.63	515.03	112.93	(78.63)	109.25
203-463-751.000	GASOLINE	1,600.00	1,600.00	2,210.02	989.81	230.40	(610.02)	138.13
203-463-756.000	OPERATING SUPPLIES	5,000.00	5,000.00	609.00	3,992.50	0.00	4,391.00	12.18
203-463-767.000	EQUIPMENT/SMALL TOOLS	1,500.00	1,500.00	0.00	0.00	0.00	1,500.00	0.00
203-463-818.000	PROFESSIONAL & CONTRACTUAL	5,000.00	5,000.00	944.00	47,170.00	0.00	4,056.00	18.88
203-463-933.000	EQUIPMENT & MAINTENANCE	5,000.00	5,000.00	0.00	1,655.62	0.00	5,000.00	0.00
203-463-939.000	VEHICLE REPAIR & MAINTENANCE	1,500.00	1,500.00	983.50	0.00	0.00	516.50	65.57
203-463-962.100	TOOLS & EQUIP	1,500.00	1,500.00	0.00	0.00	0.00	1,500.00	0.00
203-474-705.000	SALARIES SUPERVISION	3,700.00	3,700.00	6,152.34	1,992.96	644.48	(2,452.34)	166.28
203-474-706.000	SALARIES PERMANENT	5,200.00	5,200.00	9,793.73	6,846.78	1,311.30	(4,593.73)	188.34
203-474-714.000	MEDICARE	200.00	200.00	217.38	120.46	26.39	(17.38)	108.69
203-474-715.000	SOCIAL SECURITY TAX	750.00	750.00	928.66	515.04	112.91	(178.66)	123.82
203-474-756.000	OPERATING SUPPLIES	2,000.00	2,000.00	1,505.31	1,343.07	0.00	494.69	75.27
203-474-767.000	EQUIPMENT/SMALL TOOLS	0.00	0.00	0.00	0.00	0.00	0.00	0.00
203-474-784.000	OPER SUPP SNOW & ICE	15,000.00	15,000.00	9,336.13	19,301.12	0.00	5,663.87	62.24
203-474-818.000	PROFESSIONAL & CONTRACTUAL	0.00	0.00	0.00	4,668.24	0.00	0.00	0.00
203-474-933.000	EQUIPMENT & MAINTENANCE	0.00	0.00	1,587.00	0.00	1,587.00	(1,587.00)	100.00
203-478-784.000	OPER SUPP SNOW & ICE	0.00	0.00	0.00	0.00	0.00	0.00	0.00
203-482-703.000	SALARIES APPOINTED	0.00	0.00	0.00	0.00	0.00	0.00	0.00
203-482-705.000	SALARIES SUPERVISION	2,600.00	2,600.00	2,205.44	2,723.68	294.24	394.56	84.82
203-482-714.000	MEDICARE	50.00	50.00	31.54	41.16	4.08	18.46	63.08
203-482-715.000	SOCIAL SECURITY TAX	200.00	200.00	134.76	175.83	17.40	65.24	67.38
203-482-807.000	AUDIT	1,000.00	1,000.00	1,000.00	1,000.00	0.00	0.00	100.00
203-482-962.000	MISCELLANEOUS	200.00	200.00	76.55	153.17	0.00	123.45	38.28
203-482-999.130	TRANSFER TO DEBT SERVICE	0.00	0.00	0.00	0.00	0.00	0.00	0.00
203-483-818.000	PROFESSIONAL & CONTRACTUAL	124,321.00	124,321.00	0.00	5,125.00	0.00	124,321.00	0.00
TOTAL EXPENDITURES		187,206.00	187,206.00	54,806.44	107,289.77	6,323.23	132,399.56	29.28

Fund 203 - LOCAL STREET FUND:

REVENUE AND EXPENDITURE REPORT FOR CITY OF NEW BUFFALO

PERIOD ENDING 06/30/2021

% Fiscal Year Completed: 100.00

*NOTE: Available Balance / Pct Budget Used does not reflect amounts encumbered.

GL NUMBER	DESCRIPTION	2020-21		YTD BALANCE 06/30/2021	END BALANCE 06/30/2020	ACTIVITY FOR MONTH 06/30/21	AVAILABLE BALANCE	% BDGT USED
		ORIGINAL BUDGET	2020-21 AMENDED BUDGET					
Fund 203 - LOCAL STREET FUND								
TOTAL REVENUES		70,200.00	70,200.00	121,089.08	118,653.55	19,280.39	(50,889.08)	172.49
TOTAL EXPENDITURES		187,206.00	187,206.00	54,806.44	107,289.77	6,323.23	132,399.56	29.28
NET OF REVENUES & EXPENDITURES		(117,006.00)	(117,006.00)	66,282.64	11,363.78	12,957.16	(183,288.64)	56.65
BEG. FUND BALANCE		310,930.41	310,930.41	310,930.41	299,566.63			
END FUND BALANCE		193,924.41	193,924.41	377,213.05	310,930.41			
Fund 204 - MUNICIPAL STREET FUND								
Revenues								
204-000-404.000	PROPERTY TAXES	0.00	0.00	0.00	0.00	0.00	0.00	0.00
204-000-665.000	INTEREST EARNED	0.00	0.00	0.00	0.00	0.00	0.00	0.00
TOTAL REVENUES		0.00	0.00	0.00	0.00	0.00	0.00	0.00
Fund 204 - MUNICIPAL STREET FUND:								
TOTAL REVENUES		0.00	0.00	0.00	0.00	0.00	0.00	0.00
TOTAL EXPENDITURES		0.00	0.00	0.00	0.00	0.00	0.00	0.00
NET OF REVENUES & EXPENDITURES		0.00	0.00	0.00	0.00	0.00	0.00	0.00
BEG. FUND BALANCE								
END FUND BALANCE								
Fund 208 - PARK FUND								
Revenues								
208-000-566.000	GRANT	0.00	0.00	2,000.00	0.00	0.00	(2,000.00)	100.00
208-000-587.000	DONATIONS	0.00	0.00	175.00	275.00	125.00	(175.00)	100.00
208-000-628.000	SERVICE CHARGE	0.00	0.00	0.00	0.00	0.00	0.00	0.00
208-000-651.100	TRANSIENT MARINA FEES	45,000.00	45,000.00	0.44	32,213.20	0.00	44,999.56	0.00
208-000-652.000	BOAT LAUNCHING FEES	50,000.00	50,000.00	0.31	52,033.00	0.00	49,999.69	0.00
208-000-652.100	BOAT LAUNCH FEES-COMMERCIAL	28,000.00	28,000.00	0.00	22,475.00	0.00	28,000.00	0.00
208-000-653.000	CONCESSION	12,000.00	12,000.00	10,000.00	9,500.00	1,500.00	2,000.00	83.33
208-000-653.100	VENDING MACHINE REVENUE	0.00	0.00	0.00	13.00	0.00	0.00	0.00
208-000-653.200	ICE/MECHANDISE SALES	1,200.00	1,200.00	0.00	1,372.00	0.00	1,200.00	0.00
208-000-653.300	VENDOR PERCENTAGE OF SALES	6,500.00	6,500.00	48,352.10	16,495.90	0.00	(41,852.10)	743.88
208-000-654.000	BEACH PARKING FEES	255,000.00	255,000.00	231,916.47	282,966.68	3,610.58	23,083.53	90.95
208-000-655.100	PAVILION RENTAL	500.00	500.00	600.00	575.00	(25.00)	(100.00)	120.00
208-000-657.000	PARKING FINES	2,500.00	2,500.00	49,815.00	2,178.46	0.00	(47,315.00)	1,992.60
208-000-665.000	INTEREST EARNED	600.00	600.00	31.78	593.91	0.18	568.22	5.30
208-000-678.000	REIMBURSEMENTS	0.00	0.00	0.00	0.00	0.00	0.00	0.00
208-000-698.000	MISCELLANEOUS	0.00	0.00	0.00	0.00	0.00	0.00	0.00
208-000-699.000	TRANSFER FROM GENERAL	75,000.00	75,000.00	75,000.00	110,000.00	0.00	0.00	100.00
TOTAL REVENUES		476,300.00	476,300.00	417,891.10	530,691.15	5,210.76	58,408.90	87.74
Expenditures								
208-691-705.000	SALARIES SUPERVISION	80,001.00	80,001.00	61,774.29	50,793.06	6,200.10	18,226.71	77.22
208-691-706.000	SALARIES PERMANENT	56,436.00	56,436.00	42,371.22	15,958.38	5,089.93	14,064.78	75.08
208-691-706.100	SALARIES-OVERTIME	1,000.00	1,000.00	2,628.88	162.72	0.00	(1,628.88)	262.89
208-691-706.160	SALARIES-BOAT LAUNCH	34,000.00	34,000.00	0.21	25,149.21	0.00	33,999.79	0.00
208-691-706.200	SALARIES- MARINA	23,000.00	23,000.00	0.00	13,764.33	0.00	23,000.00	0.00
208-691-706.300	SALARIES-BEACH	50,000.00	50,000.00	42,888.88	64,386.78	10,793.25	7,111.12	85.78
208-691-706.400	SALARIES--PARKING ENF	0.00	0.00	586.89	0.00	586.89	(586.89)	100.00

REVENUE AND EXPENDITURE REPORT FOR CITY OF NEW BUFFALO

PERIOD ENDING 06/30/2021

% Fiscal Year Completed: 100.00

*NOTE: Available Balance / Pct Budget Used does not reflect amounts encumbered.

GL NUMBER	DESCRIPTION	2020-21		YTD BALANCE 06/30/2021	END BALANCE 06/30/2020	ACTIVITY FOR	AVAILABLE BALANCE	% BDGT USED
		ORIGINAL BUDGET	2020-21 AMENDED BUDGET			MONTH 06/30/21		
Fund 208 - PARK FUND								
Expenditures								
208-691-707.000	SALARIES PART-TIME	0.00	0.00	2,430.01	0.00	1,800.01	(2,430.01)	100.00
208-691-707.100	SALARIES-LIFEGUARDS	41,500.00	41,500.00	38,913.09	48,647.96	8,767.01	2,586.91	93.77
208-691-714.000	MEDICARE	4,252.00	4,252.00	3,134.65	3,404.59	475.12	1,117.35	73.72
208-691-715.000	SOCIAL SECURITY TAX	15,938.00	15,938.00	13,402.96	14,557.45	2,031.54	2,535.04	84.09
208-691-716.000	HEALTH INSURANCE	12,000.00	12,000.00	10,701.22	7,432.88	1,600.53	1,298.78	89.18
208-691-717.000	LIFE & DISABILITY INSURANCE	3,164.00	3,164.00	2,795.38	1,669.56	292.82	368.62	88.35
208-691-718.000	RETIREMENT	7,679.00	7,679.00	6,568.28	3,647.54	528.50	1,110.72	85.54
208-691-720.000	WORKER'S COMPENSATION INS	5,000.00	5,000.00	2,756.92	4,228.26	0.00	2,243.08	55.14
208-691-721.000	UNEMPLOYMENT COMPENSATION	8,000.00	8,000.00	2,332.84	4,283.97	0.00	5,667.16	29.16
208-691-722.000	DRUG TESTING/MEDICAL EXPENSE	2,000.00	2,000.00	175.00	490.00	35.00	1,825.00	8.75
208-691-723.000	STIPENDS	0.00	0.00	0.00	0.00	0.00	0.00	0.00
208-691-728.000	OFFICE SUPPLIES	800.00	800.00	598.84	1,481.85	1.49	201.16	74.86
208-691-751.000	GASOLINE	6,000.00	6,000.00	2,492.98	2,282.88	1,001.97	3,507.02	41.55
208-691-756.000	OPERATING SUPPLIES	9,000.00	9,000.00	10,668.88	10,828.87	487.05	(1,668.88)	118.54
208-691-756.500	MERCHANDISE	1,500.00	1,500.00	0.00	0.00	0.00	1,500.00	0.00
208-691-767.000	EQUIPMENT/SMALL TOOLS	6,500.00	6,500.00	6,100.87	5,039.06	593.53	399.13	93.86
208-691-768.000	UNIFORMS	2,500.00	2,500.00	3,834.37	3,224.43	490.76	(1,334.37)	153.37
208-691-801.000	EDUCATION & TRAINING	1,000.00	1,000.00	500.00	0.00	500.00	500.00	50.00
208-691-807.000	AUDIT	1,000.00	1,000.00	1,000.00	1,000.00	0.00	0.00	100.00
208-691-818.000	PROFESSIONAL & CONTRACTUAL	35,000.00	55,000.00	61,257.00	41,903.23	3,478.00	(6,257.00)	111.38
208-691-818.200	ENGINEERING	2,000.00	2,000.00	0.00	0.00	0.00	2,000.00	0.00
208-691-831.000	MEMBERSHIPS & DUES	400.00	400.00	175.00	0.00	0.00	225.00	43.75
208-691-853.000	TELEPHONE	2,500.00	2,500.00	2,492.50	2,086.07	130.49	7.50	99.70
208-691-854.200	SOFTWARE EXPENSE	2,050.00	2,050.00	0.00	0.00	0.00	2,050.00	0.00
208-691-903.000	PRINTING & PUBLISHING	1,500.00	1,500.00	3,669.51	3,096.03	481.00	(2,169.51)	244.63
208-691-912.000	FIRE INSURANCE	1,700.00	1,700.00	2,078.73	1,868.15	399.90	(378.73)	122.28
208-691-913.000	INSURANCE	3,000.00	3,000.00	5,104.80	3,704.64	1,040.00	(2,104.80)	170.16
208-691-916.000	LIABILITY INSURANCE	8,500.00	8,500.00	8,966.91	7,502.71	1,783.94	(466.91)	105.49
208-691-920.000	UTILITIES	35,000.00	35,000.00	20,673.75	30,254.10	(3,509.59)	14,326.25	59.07
208-691-931.000	BUILDING REPAIR & MAINTENANCE	15,000.00	15,000.00	18,210.13	28,281.83	1,366.23	(3,210.13)	121.40
208-691-932.000	GROUNDS REPAIR & MAINT	15,000.00	15,000.00	17,207.43	37,469.73	1,746.23	(2,207.43)	114.72
208-691-933.000	EQUIPMENT & MAINTENANCE	5,000.00	5,000.00	17,085.88	2,482.06	1,366.25	(12,085.88)	341.72
208-691-933.100	EQUIPMENT MAINT--PARKING SYSTE	2,760.00	2,760.00	4,689.00	2,925.12	320.00	(1,929.00)	169.89
208-691-933.200	EQUIPMENT LEASES	10,767.00	10,767.00	13,035.72	11,194.06	1,083.60	(2,268.72)	121.07
208-691-939.000	VEHICLE REPAIR & MAINTENANCE	4,000.00	4,000.00	4,731.87	2,902.46	1,174.75	(731.87)	118.30
208-691-943.000	EQUIPMENT RENTAL	1,000.00	1,000.00	1,050.00	0.00	0.00	(50.00)	105.00
208-691-956.200	REFUNDS	350.00	350.00	0.00	0.00	0.00	350.00	0.00
208-691-962.000	MISCELLANEOUS	0.00	0.00	0.00	0.00	0.00	0.00	0.00
208-691-963.000	BANK FEES	8,000.00	8,000.00	9,401.25	7,446.49	0.00	(1,401.25)	117.52
208-691-967.000	MISC PROJECTS	5,000.00	5,000.00	3,854.35	7,779.19	0.00	1,145.65	77.09
208-691-970.000	CAPITAL IMPROVEMENTS	5,000.00	5,000.00	4,455.00	6,000.00	0.00	545.00	89.10
208-691-979.000	EQUIPMENT	5,000.00	5,000.00	525.28	66.88	175.29	4,474.72	10.51
208-691-979.200	LIFEGUARD EQUIPMENT	2,164.00	2,164.00	3,407.11	4,775.61	0.00	(1,243.11)	157.45
208-691-979.300	LIFEGUARD RECRUITMENT & TRAINI	4,250.00	4,250.00	1,675.00	1,330.91	0.00	2,575.00	39.41
208-691-983.000	VEHICLE LEASES	0.00	0.00	0.00	0.00	0.00	0.00	0.00
208-691-999.000	TRANSFERS OUT	0.00	0.00	0.00	66,727.40	0.00	0.00	0.00
208-691-999.500	TRANSFER TO DREDGE FUND	0.00	0.00	0.00	0.00	0.00	0.00	0.00
TOTAL EXPENDITURES		547,211.00	567,211.00	462,402.88	552,230.45	52,311.59	104,808.12	81.52

REVENUE AND EXPENDITURE REPORT FOR CITY OF NEW BUFFALO

PERIOD ENDING 06/30/2021

% Fiscal Year Completed: 100.00

*NOTE: Available Balance / Pct Budget Used does not reflect amounts encumbered.

GL NUMBER	DESCRIPTION	2020-21		YTD BALANCE 06/30/2021	END BALANCE 06/30/2020	ACTIVITY FOR MONTH 06/30/21	AVAILABLE BALANCE	% BDGT USED
		ORIGINAL BUDGET	2020-21 AMENDED BUDGET					
Fund 208 - PARK FUND								
TOTAL REVENUES		476,300.00	476,300.00	417,891.10	530,691.15	5,210.76	58,408.90	87.74
TOTAL EXPENDITURES		547,211.00	567,211.00	462,402.88	552,230.45	52,311.59	104,808.12	81.52
NET OF REVENUES & EXPENDITURES		(70,911.00)	(90,911.00)	(44,511.78)	(21,539.30)	(47,100.83)	(46,399.22)	48.96
BEG. FUND BALANCE		255,518.85	255,518.85	255,518.85	277,058.15			
END FUND BALANCE		184,607.85	164,607.85	211,007.07	255,518.85			
Fund 209 - PARK IMPROVEMENT FUND								
Revenues								
209-000-404.000	PROPERTY TAXES	111,925.00	111,925.00	111,925.00	109,092.95	0.00	0.00	100.00
209-000-445.000	PENALTY & INTEREST	200.00	200.00	253.04	248.23	43.96	(53.04)	126.52
209-000-587.000	DONATIONS	0.00	0.00	0.00	0.00	0.00	0.00	0.00
209-000-665.000	INTEREST EARNED	100.00	100.00	30.30	183.89	0.00	69.70	30.30
209-000-698.000	MISCELLANEOUS	0.00	0.00	0.00	0.00	0.00	0.00	0.00
209-000-699.100	TRANSFER IN	0.00	0.00	0.00	66,727.40	0.00	0.00	0.00
TOTAL REVENUES		112,225.00	112,225.00	112,208.34	176,252.47	43.96	16.66	99.99
Expenditures								
209-000-981.300	PARK VEHICLES & EQUIPMENT	0.00	0.00	0.00	0.00	0.00	0.00	0.00
209-691-999.500	TRANSFER TO DREDGE FUND	36,288.00	36,288.00	36,288.00	35,800.00	0.00	0.00	100.00
209-751-818.200	ENGINEERING	0.00	0.00	0.00	0.00	0.00	0.00	0.00
209-751-962.000	MISCELLANEOUS	0.00	0.00	0.00	0.00	0.00	0.00	0.00
209-751-974.000	CAPITAL IMPROVEMENTS	110,000.00	160,000.00	82,350.00	15,350.00	0.00	77,650.00	51.47
TOTAL EXPENDITURES		146,288.00	196,288.00	118,638.00	51,150.00	0.00	77,650.00	60.44
Fund 209 - PARK IMPROVEMENT FUND:								
TOTAL REVENUES		112,225.00	112,225.00	112,208.34	176,252.47	43.96	16.66	99.99
TOTAL EXPENDITURES		146,288.00	196,288.00	118,638.00	51,150.00	0.00	77,650.00	60.44
NET OF REVENUES & EXPENDITURES		(34,063.00)	(84,063.00)	(6,429.66)	125,102.47	43.96	(77,633.34)	7.65
BEG. FUND BALANCE		163,186.43	163,186.43	163,186.43	38,083.96			
END FUND BALANCE		129,123.43	79,123.43	156,756.77	163,186.43			
Fund 225 - DREDGE FUND								
Revenues								
225-000-566.000	GRANT	0.00	0.00	0.00	0.00	0.00	0.00	0.00
225-000-589.000	CONTRIBUTIONS	36,288.00	36,288.00	28,116.00	9,182.00	0.00	8,172.00	77.48
225-000-665.000	INTEREST EARNED	600.00	600.00	204.13	1,210.02	18.07	395.87	34.02
225-000-699.100	TRANSFER IN	36,288.00	36,288.00	36,288.00	35,800.00	0.00	0.00	100.00
TOTAL REVENUES		73,176.00	73,176.00	64,608.13	46,192.02	18.07	8,567.87	88.29
Expenditures								
225-806-818.000	PROFESSIONAL & CONTRACTUAL	200,000.00	200,000.00	0.00	3,410.00	0.00	200,000.00	0.00
TOTAL EXPENDITURES		200,000.00	200,000.00	0.00	3,410.00	0.00	200,000.00	0.00

REVENUE AND EXPENDITURE REPORT FOR CITY OF NEW BUFFALO

PERIOD ENDING 06/30/2021

% Fiscal Year Completed: 100.00

*NOTE: Available Balance / Pct Budget Used does not reflect amounts encumbered.

GL NUMBER	DESCRIPTION	2020-21		YTD BALANCE 06/30/2021	END BALANCE 06/30/2020	ACTIVITY FOR MONTH 06/30/21	AVAILABLE BALANCE	% BDGT USED
		ORIGINAL BUDGET	2020-21 AMENDED BUDGET					
Fund 265 - DRUG LAW ENFORCEMENT FUND								
Fund 265 - DRUG LAW ENFORCEMENT FUND:								
	TOTAL REVENUES	0.00	0.00	0.02	0.10	0.00	(0.02)	100.00
	TOTAL EXPENDITURES	0.00	0.00	0.00	0.00	0.00	0.00	0.00
	NET OF REVENUES & EXPENDITURES	0.00	0.00	0.02	0.10	0.00	(0.02)	100.00
	BEG. FUND BALANCE	120.96	120.96	120.96	120.86			
	END FUND BALANCE	120.96	120.96	120.98	120.96			
Fund 266 - CRIMINAL JUSTICE TRAINING (ACT 302)								
Revenues								
266-000-580.000	STATE REVENUE JUSTICE TRAINING	1,300.00	1,300.00	892.08	1,290.24	0.00	407.92	68.62
266-000-665.000	INTEREST EARNED	0.00	0.00	0.11	1.51	0.00	(0.11)	100.00
266-000-699.000	TRANSFER FROM GENERAL	0.00	0.00	0.00	0.00	0.00	0.00	0.00
	TOTAL REVENUES	1,300.00	1,300.00	892.19	1,291.75	0.00	407.81	68.63
Expenditures								
266-000-961.000	CRIMINAL JUSTICE TRAINING	0.00	0.00	155.51	451.58	0.00	(155.51)	100.00
	TOTAL EXPENDITURES	0.00	0.00	155.51	451.58	0.00	(155.51)	100.00
Fund 266 - CRIMINAL JUSTICE TRAINING (ACT 302):								
	TOTAL REVENUES	1,300.00	1,300.00	892.19	1,291.75	0.00	407.81	68.63
	TOTAL EXPENDITURES	0.00	0.00	155.51	451.58	0.00	(155.51)	100.00
	NET OF REVENUES & EXPENDITURES	1,300.00	1,300.00	736.68	840.17	0.00	563.32	56.67
	BEG. FUND BALANCE	1,257.24	1,257.24	1,257.24	417.07			
	END FUND BALANCE	2,557.24	2,557.24	1,993.92	1,257.24			
Fund 351 - DEBT SERVICE								
Revenues								
351-000-665.000	INTEREST EARNED	800.00	75.00	74.94	745.84	0.13	0.06	99.92
351-000-699.000	TRANSFER FROM GENERAL	127,543.00	127,543.00	127,543.00	128,313.00	0.00	0.00	100.00
351-000-699.100	TRANSFER IN FROM WATER	84,825.00	84,825.00	84,825.00	85,338.00	0.00	0.00	100.00
351-000-699.200	TRANSFER IN FROM SEWER	126,932.00	126,932.00	126,932.00	127,699.00	0.00	0.00	100.00
351-000-699.312	TRANSFER FROM LRSB FOR 2010 SE	0.00	0.00	0.00	51,063.00	0.00	0.00	0.00
	TOTAL REVENUES	340,100.00	339,375.00	339,374.94	393,158.84	0.13	0.06	100.00
Expenditures								
351-906-991.100	2017 CAP IMPROV BOND PRINCIPLE	240,000.00	240,000.00	240,000.00	235,000.00	0.00	0.00	100.00
351-906-992.100	2017 CAP IMPROV BOND INTEREST	99,300.00	99,300.00	99,300.00	106,350.00	0.00	0.00	100.00
351-906-993.700	2010 SEAWALL - PRINCIPAL	0.00	0.00	0.00	50,000.00	0.00	0.00	0.00
351-906-993.800	2010 SEAWALL - INTEREST	0.00	0.00	0.00	1,087.50	0.00	0.00	0.00
351-906-998.000	FEES	800.00	800.00	0.00	0.00	0.00	800.00	0.00
	TOTAL EXPENDITURES	340,100.00	340,100.00	339,300.00	392,437.50	0.00	800.00	99.76

REVENUE AND EXPENDITURE REPORT FOR CITY OF NEW BUFFALO

PERIOD ENDING 06/30/2021

% Fiscal Year Completed: 100.00

*NOTE: Available Balance / Pct Budget Used does not reflect amounts encumbered.

GL NUMBER	DESCRIPTION	2020-21		YTD BALANCE 06/30/2021	END BALANCE 06/30/2020	ACTIVITY FOR MONTH 06/30/21	AVAILABLE BALANCE	% BDGT USED
		ORIGINAL BUDGET	2020-21 AMENDED BUDGET					
Fund 403 - CAPITAL IMPROV CONSTRUCTION								
Revenues								
TOTAL REVENUES		0.00	0.00	43.63	2,051.81	2.78	(43.63)	100.00
Expenditures								
403-903-976.000	N. WHITTAKER REDEVELOPMENT	0.00	0.00	0.00	0.00	0.00	0.00	0.00
403-903-976.100	STROMER & SHORE PROJECT	0.00	0.00	0.00	0.00	0.00	0.00	0.00
403-903-976.200	STREET PAVING PROGRAM	105,362.00	210,724.00	44,969.60	606,000.72	0.00	165,754.40	21.34
403-903-976.300	CLAY STREET RECONSTRUCTION	0.00	0.00	0.00	0.00	0.00	0.00	0.00
403-903-998.000	FEES	0.00	950.00	1,250.00	950.00	500.00	(300.00)	131.58
TOTAL EXPENDITURES		105,362.00	211,674.00	46,219.60	606,950.72	500.00	165,454.40	21.84
Fund 403 - CAPITAL IMPROV CONSTRUCTION:								
TOTAL REVENUES		0.00	0.00	43.63	2,051.81	2.78	(43.63)	100.00
TOTAL EXPENDITURES		105,362.00	211,674.00	46,219.60	606,950.72	500.00	165,454.40	21.84
NET OF REVENUES & EXPENDITURES		(105,362.00)	(211,674.00)	(46,175.97)	(604,898.91)	(497.22)	(165,498.03)	21.81
BEG. FUND BALANCE		106,296.14	106,296.14	106,296.14	711,195.05			
END FUND BALANCE		934.14	(105,377.86)	60,120.17	106,296.14			
Fund 590 - SEWER FUND								
Revenues								
590-000-566.000	GRANT	0.00	0.00	0.00	0.00	0.00	0.00	0.00
590-000-641.000	TAP IN FEES	6,000.00	6,000.00	9,705.73	5,462.43	0.00	(3,705.73)	161.76
590-000-641.100	TAP BUY INS	25,000.00	25,000.00	20,770.77	28,788.00	0.00	4,229.23	83.08
590-000-641.300	INSPECTION FEES	500.00	500.00	237.00	316.00	0.00	263.00	47.40
590-000-641.400	CONNECTION FEE	1,500.00	1,500.00	1,050.00	1,400.00	0.00	450.00	70.00
590-000-650.000	USAGE	468,750.00	468,750.00	450,316.94	419,817.39	41,094.89	18,433.06	96.07
590-000-650.100	READY TO SERVE	562,500.00	562,500.00	574,777.86	562,893.47	58,048.43	(12,277.86)	102.18
590-000-662.000	PENALTIES	9,000.00	9,000.00	8,472.62	10,285.25	555.11	527.38	94.14
590-000-665.000	INTEREST EARNED	2,000.00	2,000.00	158.41	3,879.95	0.03	1,841.59	7.92
590-000-670.000	INCOME FROM JOINT VENTURE	0.00	0.00	0.00	(90,607.00)	0.00	0.00	0.00
590-000-683.000	CHANGE IN ESTIMATE	0.00	0.00	0.00	125,000.00	0.00	0.00	0.00
590-000-698.000	MISCELLANEOUS	0.00	0.00	740.58	1,234.30	0.00	(740.58)	100.00
590-000-699.000	TRANSFER IN	0.00	0.00	0.00	0.00	0.00	0.00	0.00
TOTAL REVENUES		1,075,250.00	1,075,250.00	1,066,229.91	1,068,469.79	99,698.46	9,020.09	99.16
Expenditures								
590-537-705.000	SALARIES SUPERVISION	27,500.00	27,500.00	20,580.63	16,560.50	2,418.83	6,919.37	74.84
590-537-706.000	SALARIES PERMANENT	34,893.00	34,893.00	40,450.52	32,499.62	5,049.78	(5,557.52)	115.93
590-537-706.100	SALARIES-OVERTIME	0.00	0.00	0.00	0.00	0.00	0.00	0.00
590-537-714.000	MEDICARE	800.00	800.00	844.02	703.26	102.19	(44.02)	105.50
590-537-715.000	SOCIAL SECURITY TAX	3,300.00	3,300.00	3,608.04	3,006.84	436.78	(308.04)	109.33
590-537-730.000	POSTAGE	1,800.00	1,800.00	800.00	1,800.00	0.00	1,000.00	44.44
590-537-751.000	GASOLINE	0.00	0.00	0.00	0.00	0.00	0.00	0.00
590-537-756.000	OPERATING SUPPLIES	300.00	300.00	0.00	152.09	0.00	300.00	0.00
590-537-807.000	AUDIT	1,000.00	1,000.00	2,000.00	2,000.00	0.00	(1,000.00)	200.00
590-537-818.000	PROFESSIONAL & CONTRACTUAL	3,000.00	3,000.00	0.00	321.48	0.00	3,000.00	0.00
590-537-818.200	ENGINEERING	40,000.00	40,000.00	750.00	36,933.70	0.00	39,250.00	1.88
590-537-836.000	GALIEN RIVER SANITARY DISTRICT	825,000.00	825,000.00	476,901.42	933,490.94	0.00	348,098.58	57.81

REVENUE AND EXPENDITURE REPORT FOR CITY OF NEW BUFFALO

PERIOD ENDING 06/30/2021

% Fiscal Year Completed: 100.00

*NOTE: Available Balance / Pct Budget Used does not reflect amounts encumbered.

GL NUMBER	DESCRIPTION	2020-21		YTD BALANCE 06/30/2021	END BALANCE 06/30/2020	ACTIVITY FOR MONTH 06/30/21	AVAILABLE BALANCE	% BDGT USED
		ORIGINAL BUDGET	2020-21 AMENDED BUDGET					
Fund 590 - SEWER FUND								
Expenditures								
590-537-836.100	GRSD MAINTENANCE	40,000.00	40,000.00	29,239.31	19,008.75	289.04	10,760.69	73.10
590-537-836.300	GRSD - CAPITAL IMPROVEMENT	0.00	0.00	0.00	0.00	0.00	0.00	0.00
590-537-836.500	GRSD-CONNECTION FEES	3,500.00	3,500.00	700.00	1,400.00	0.00	2,800.00	20.00
590-537-903.000	PRINTING & PUBLISHING	0.00	0.00	155.41	0.00	155.41	(155.41)	100.00
590-537-916.000	LIABILITY INSURANCE	3,000.00	3,000.00	3,196.70	2,590.27	638.40	(196.70)	106.56
590-537-920.000	UTILITIES	6,500.00	6,500.00	16,948.93	12,292.58	2,724.08	(10,448.93)	260.75
590-537-933.000	EQUIPMENT & MAINTENANCE	4,000.00	4,000.00	0.00	13.71	0.00	4,000.00	0.00
590-537-935.000	SEWER REPAIR & MAINTENANCE	17,000.00	17,000.00	0.00	13,047.10	0.00	17,000.00	0.00
590-537-935.200	N. WHITTKER REDEVELOPMENT	0.00	0.00	0.00	0.00	0.00	0.00	0.00
590-537-937.000	SEWER CONNECTIONS/MAINTENANCE	1,000.00	1,000.00	5,200.00	11,400.00	0.00	(4,200.00)	520.00
590-537-943.000	EQUIPMENT RENTAL	400.00	400.00	0.00	0.00	0.00	400.00	0.00
590-537-956.200	REFUNDS	250.00	250.00	0.00	0.00	0.00	250.00	0.00
590-537-962.000	MISCELLANEOUS	250.00	250.00	181.75	(231.58)	0.00	68.25	72.70
590-537-991.000	DEPRECIATION EXPENSE	0.00	0.00	0.00	47,105.00	0.00	0.00	0.00
590-537-995.000	INTERFUND TRANSFERS	24,690.00	24,690.00	24,690.27	26,237.09	0.00	(0.27)	100.00
590-537-995.100	TRANSFER TO DEBT SERVICE 2017	126,932.00	126,932.00	126,932.00	127,699.00	0.00	0.00	100.00
TOTAL EXPENDITURES		1,165,115.00	1,165,115.00	753,179.00	1,288,030.35	11,814.51	411,936.00	64.64
Fund 590 - SEWER FUND:								
TOTAL REVENUES		1,075,250.00	1,075,250.00	1,066,229.91	1,068,469.79	99,698.46	9,020.09	99.16
TOTAL EXPENDITURES		1,165,115.00	1,165,115.00	753,179.00	1,288,030.35	11,814.51	411,936.00	64.64
NET OF REVENUES & EXPENDITURES		(89,865.00)	(89,865.00)	313,050.91	(219,560.56)	87,883.95	(402,915.91)	348.36
BEG. FUND BALANCE		3,940,790.99	3,940,790.99	3,940,790.99	4,160,351.55			
END FUND BALANCE		3,850,925.99	3,850,925.99	4,253,841.90	3,940,790.99			
Fund 591 - WATER FUND								
Revenues								
591-000-626.000	SERVICES RENDERED	500.00	500.00	1,914.00	125.00	658.00	(1,414.00)	382.80
591-000-641.000	TAP IN FEES	23,000.00	23,000.00	17,978.05	13,422.07	0.00	5,021.95	78.17
591-000-641.100	TAP BUY INS	10,000.00	10,000.00	10,977.23	7,966.00	0.00	(977.23)	109.77
591-000-641.200	WATER TAP SUPPLY REIM	0.00	0.00	0.00	6,122.55	0.00	0.00	0.00
591-000-648.000	USAGE - CASINO	340,000.00	340,000.00	338,220.70	365,814.49	22,633.64	1,779.30	99.48
591-000-649.000	USAGE-TWP	10,000.00	10,000.00	13,163.11	9,761.42	249.91	(3,163.11)	131.63
591-000-650.000	USAGE	330,000.00	330,000.00	326,052.62	297,926.11	28,971.72	3,947.38	98.80
591-000-650.100	READY TO SERVE	400,000.00	400,000.00	422,985.23	420,547.68	43,933.37	(22,985.23)	105.75
591-000-650.200	RTS - CASINO	23,000.00	23,000.00	23,386.08	25,334.92	1,948.84	(386.08)	101.68
591-000-651.000	ON/OFF FEES	1,500.00	1,500.00	5,916.50	3,365.00	750.00	(4,416.50)	394.43
591-000-662.000	PENALTIES	6,500.00	6,500.00	5,700.66	6,733.56	365.83	799.34	87.70
591-000-665.000	INTEREST EARNED	12,000.00	12,000.00	486.80	18,044.74	0.19	11,513.20	4.06
591-000-670.000	RENTAL/LEASE	0.00	0.00	0.00	15,000.00	0.00	0.00	0.00
591-000-680.000	HYDRANT RENTAL	100.00	100.00	416.00	130.50	0.00	(316.00)	416.00
591-000-698.000	MISCELLANEOUS	0.00	0.00	0.00	670.00	0.00	0.00	0.00
TOTAL REVENUES		1,156,600.00	1,156,600.00	1,167,196.98	1,190,964.04	99,511.50	(10,596.98)	100.92
Expenditures								
591-536-705.000	SALARIES SUPERVISION	126,233.00	126,233.00	115,746.15	94,657.96	13,244.03	10,486.85	91.69
591-536-706.000	SALARIES PERMANENT	177,846.00	177,846.00	182,935.09	184,501.10	20,636.64	(5,089.09)	102.86

REVENUE AND EXPENDITURE REPORT FOR CITY OF NEW BUFFALO

PERIOD ENDING 06/30/2021

% Fiscal Year Completed: 100.00

*NOTE: Available Balance / Pct Budget Used does not reflect amounts encumbered.

GL NUMBER	DESCRIPTION	2020-21		YTD BALANCE 06/30/2021	END BALANCE 06/30/2020	ACTIVITY FOR MONTH 06/30/21	AVAILABLE BALANCE	% BDGT USED
		ORIGINAL BUDGET	2020-21 AMENDED BUDGET					
Fund 591 - WATER FUND								
Expenditures								
591-536-706.100	SALARIES-OVERTIME	22,000.00	22,000.00	17,183.74	15,622.26	2,330.09	4,816.26	78.11
591-536-714.000	MEDICARE	4,728.00	4,728.00	4,364.48	4,432.17	489.07	363.52	92.31
591-536-715.000	SOCIAL SECURITY TAX	20,217.00	20,217.00	18,662.19	18,951.60	2,091.27	1,554.81	92.31
591-536-716.000	HEALTH INSURANCE	79,100.00	79,100.00	82,589.57	71,333.95	6,627.84	(3,489.57)	104.41
591-536-717.000	LIFE & DISABILITY INSURANCE	7,290.00	7,290.00	8,514.25	7,814.52	699.73	(1,224.25)	116.79
591-536-718.000	RETIREMENT	19,799.00	19,799.00	20,275.37	3,303.37	1,562.02	(476.37)	102.41
591-536-720.000	WORKER'S COMPENSATION INS	9,400.00	9,400.00	4,863.78	7,770.96	0.00	4,536.22	51.74
591-536-721.000	UNEMPLOYMENT COMPENSATION	1,950.00	1,950.00	736.64	750.74	0.00	1,213.36	37.78
591-536-723.000	STIPENDS	4,900.00	4,900.00	5,158.28	5,300.00	108.28	(258.28)	105.27
591-536-728.000	OFFICE SUPPLIES	800.00	800.00	122.22	765.52	82.20	677.78	15.28
591-536-730.000	POSTAGE	2,800.00	2,800.00	1,265.44	2,095.94	0.00	1,534.56	45.19
591-536-743.000	CHEMICALS	0.00	0.00	0.00	0.00	0.00	0.00	0.00
591-536-751.000	GASOLINE	5,500.00	5,500.00	3,133.26	3,568.04	687.22	2,366.74	56.97
591-536-753.000	PROCESS CHEMICALS	25,000.00	25,000.00	24,250.40	15,097.17	5,062.78	749.60	97.00
591-536-756.000	OPERATING SUPPLIES	23,000.00	23,000.00	14,828.04	19,389.76	(276.27)	8,171.96	64.47
591-536-756.100	SUPPLIES - WATER TAPS	7,500.00	7,500.00	4,987.32	5,864.42	106.00	2,512.68	66.50
591-536-756.200	METER REPLACEMENT	17,000.00	17,000.00	7,478.40	13,108.05	1,084.99	9,521.60	43.99
591-536-756.300	MISC TESTING SUPPLIES&TESTING	7,500.00	7,500.00	8,221.66	4,476.88	1,890.01	(721.66)	109.62
591-536-756.400	LAB SUPPLIES	22,000.00	22,000.00	20,578.69	13,898.30	3,501.43	1,421.31	93.54
591-536-767.000	EQUIPMENT/SMALL TOOLS	5,500.00	5,500.00	646.24	2,870.22	73.12	4,853.76	11.75
591-536-768.000	UNIFORMS	1,600.00	1,600.00	895.92	850.67	(30.02)	704.08	56.00
591-536-801.000	EDUCATION & TRAINING	3,800.00	3,800.00	760.00	1,951.66	0.00	3,040.00	20.00
591-536-807.000	AUDIT	2,000.00	2,000.00	2,000.00	2,000.00	0.00	0.00	100.00
591-536-818.000	PROFESSIONAL & CONTRACTUAL	28,000.00	28,000.00	27,441.24	16,795.35	75.00	558.76	98.00
591-536-818.200	ENGINEERING	60,000.00	60,000.00	19,756.50	3,861.02	0.00	40,243.50	32.93
591-536-818.600	CONTRACTUAL-WATER TAPS	7,500.00	7,500.00	4,473.50	9,760.96	0.00	3,026.50	59.65
591-536-818.700	SLUDGE REMOVAL	0.00	0.00	0.00	27,483.66	0.00	0.00	0.00
591-536-818.800	WATER INTAKE SERVICE	12,000.00	12,000.00	0.00	11,500.00	0.00	12,000.00	0.00
591-536-819.500	PERMIT FEE	150.00	150.00	245.00	226.50	0.00	(95.00)	163.33
591-536-824.000	LAB CERTIFICATION FEE	4,000.00	4,000.00	1,300.05	4,076.42	0.00	2,699.95	32.50
591-536-831.000	MEMBERSHIPS & DUES	1,500.00	1,500.00	1,769.58	1,444.49	0.00	(269.58)	117.97
591-536-853.000	TELEPHONE	12,000.00	12,000.00	8,189.17	10,064.36	527.03	3,810.83	68.24
591-536-873.000	TRAVEL/MILEAGE REIMB	450.00	450.00	0.00	0.00	0.00	450.00	0.00
591-536-903.000	PRINTING & PUBLISHING	800.00	800.00	155.41	1,254.09	155.41	644.59	19.43
591-536-912.000	FIRE INSURANCE	13,000.00	13,000.00	13,927.46	12,516.62	2,679.33	(927.46)	107.13
591-536-913.000	INSURANCE	3,000.00	3,000.00	3,062.89	2,041.27	624.00	(62.89)	102.10
591-536-916.000	LIABILITY INSURANCE	3,500.00	3,500.00	2,988.98	2,500.91	594.65	511.02	85.40
591-536-920.000	UTILITIES	55,000.00	55,000.00	39,255.69	49,938.75	2,568.93	15,744.31	71.37
591-536-930.000	PLANT REPAIR & MAINTENANCE	15,000.00	15,000.00	977.45	1,235.68	112.50	14,022.55	6.52
591-536-931.000	BUILDING REPAIR & MAINTENANCE	210,000.00	210,000.00	178,013.73	16,388.63	164,796.54	31,986.27	84.77
591-536-933.000	EQUIPMENT & MAINTENANCE	40,000.00	40,000.00	24,153.08	26,286.77	8,288.06	15,846.92	60.38
591-536-934.000	OTHER REPAIRS & MAINT	10,000.00	10,000.00	5,637.30	700.00	0.00	4,362.70	56.37
591-536-939.000	VEHICLE REPAIR & MAINTENANCE	6,500.00	6,500.00	1,463.61	1,173.06	1,174.75	5,036.39	22.52
591-536-943.000	EQUIPMENT RENTAL	250.00	250.00	0.00	0.00	0.00	250.00	0.00
591-536-955.000	CUSTOMER DEPOSIT REFUNDS	0.00	0.00	0.00	0.00	0.00	0.00	0.00
591-536-956.200	REFUNDS	1,500.00	1,500.00	0.00	0.00	0.00	1,500.00	0.00
591-536-962.000	MISCELLANEOUS	0.00	0.00	(2,537.50)	(83.00)	0.00	2,537.50	100.00
591-536-963.000	BANK FEES	3,000.00	3,000.00	682.88	2,000.96	0.00	2,317.12	22.76
591-536-974.700	PLANT SECURITY EXPENSE	2,500.00	2,500.00	1,010.00	430.00	0.00	1,490.00	40.40
591-536-979.000	EQUIPMENT	10,000.00	10,000.00	0.00	6,257.42	0.00	10,000.00	0.00
591-536-979.400	WATER METER REPLACEMENT	0.00	0.00	0.00	0.00	0.00	0.00	0.00
591-536-979.500	HYDRANT REPLACEMENT	7,500.00	7,500.00	(9.46)	1,120.00	0.00	7,509.46	(0.13)
591-536-983.000	VEHICLE LEASES	0.00	0.00	0.00	0.00	0.00	0.00	0.00
591-536-987.000	WATER MAIN EXTENSIONS	65,000.00	65,000.00	0.00	50,225.29	0.00	65,000.00	0.00

REVENUE AND EXPENDITURE REPORT FOR CITY OF NEW BUFFALO

PERIOD ENDING 06/30/2021

% Fiscal Year Completed: 100.00

*NOTE: Available Balance / Pct Budget Used does not reflect amounts encumbered.

GL NUMBER	DESCRIPTION	2020-21		YTD BALANCE 06/30/2021	END BALANCE 06/30/2020	ACTIVITY FOR MONTH 06/30/21	AVAILABLE BALANCE	% BDGT USED
		ORIGINAL BUDGET	2020-21 AMENDED BUDGET					
Fund 594 - HARBOR OPERATIONS								
Expenditures								
594-597-818.000	PROFESSIONAL & CONTRACTUAL	0.00	75,000.00	46,547.62	0.00	12,508.92	28,452.38	62.06
594-597-818.200	ENGINEERING	0.00	13,000.00	8,850.00	0.00	8,850.00	4,150.00	68.08
594-597-916.000	LIABILITY INSURANCE	0.00	0.00	0.00	0.00	0.00	0.00	0.00
594-597-920.000	UTILITIES	0.00	11,000.00	9,605.49	0.00	6,332.25	1,394.51	87.32
594-597-931.000	BUILDING REPAIR & MAINTENANCE	0.00	0.00	3,572.09	0.00	2,528.22	(3,572.09)	100.00
594-597-932.000	GROUNDS REPAIR & MAINT	0.00	8,000.00	10,531.15	0.00	6,202.98	(2,531.15)	131.64
594-597-933.000	EQUIPMENT & MAINTENANCE	0.00	0.00	410.02	0.00	0.00	(410.02)	100.00
594-597-956.200	REFUNDS	0.00	0.00	1,197.88	0.00	0.00	(1,197.88)	100.00
594-597-963.000	BANK FEES	0.00	0.00	0.00	0.00	0.00	0.00	0.00
594-597-970.000	CAPITAL IMPROVEMENTS	0.00	20,000.00	852.39	0.00	(5,500.00)	19,147.61	4.26
TOTAL EXPENDITURES		0.00	192,055.00	139,478.73	0.00	45,579.99	52,576.27	72.62
Fund 594 - HARBOR OPERATIONS:								
TOTAL REVENUES		0.00	151,000.00	201,463.43	0.00	58,626.64	(50,463.43)	133.42
TOTAL EXPENDITURES		0.00	192,055.00	139,478.73	0.00	45,579.99	52,576.27	72.62
NET OF REVENUES & EXPENDITURES		0.00	(41,055.00)	61,984.70	0.00	13,046.65	(103,039.70)	150.98
BEG. FUND BALANCE								
END FUND BALANCE			(41,055.00)	61,984.70				
Fund 599 - WATER MAINT RESERVE FUND								
Revenues								
599-000-589.100	CONTRIBUTIONS-CASINO	0.00	0.00	0.00	0.00	0.00	0.00	0.00
599-000-641.100	TAP BUY INS	0.00	0.00	0.00	0.00	0.00	0.00	0.00
599-000-665.000	INTEREST EARNED	0.00	0.00	432.47	11,895.69	0.00	(432.47)	100.00
599-000-678.100	REIMB-COUNTY	0.00	0.00	0.00	0.00	0.00	0.00	0.00
599-000-695.200	TRANSFER FROM WATER	0.00	0.00	0.00	0.00	0.00	0.00	0.00
599-000-698.000	MISCELLANEOUS	0.00	0.00	0.00	0.00	0.00	0.00	0.00
TOTAL REVENUES		0.00	0.00	432.47	11,895.69	0.00	(432.47)	100.00
Expenditures								
599-539-962.000	MISCELLANEOUS	0.00	0.00	642.44	1,424.05	0.00	(642.44)	100.00
599-539-970.000	CAPITAL IMPROVEMENTS	0.00	0.00	0.00	0.00	0.00	0.00	0.00
599-539-987.100	WATER MAIN REPLACEMENT--MECHAN	0.00	0.00	0.00	0.00	0.00	0.00	0.00
599-539-989.000	PLANT EXPANSION	0.00	0.00	0.00	0.00	0.00	0.00	0.00
599-539-991.000	DEPRECIATION EXPENSE	0.00	0.00	0.00	46,790.00	0.00	0.00	0.00
599-539-999.100	TRANSFER TO WATER	0.00	0.00	0.00	0.00	0.00	0.00	0.00
TOTAL EXPENDITURES		0.00	0.00	642.44	48,214.05	0.00	(642.44)	100.00
Fund 599 - WATER MAINT RESERVE FUND:								
TOTAL REVENUES		0.00	0.00	432.47	11,895.69	0.00	(432.47)	100.00
TOTAL EXPENDITURES		0.00	0.00	642.44	48,214.05	0.00	(642.44)	100.00
NET OF REVENUES & EXPENDITURES		0.00	0.00	(209.97)	(36,318.36)	0.00	209.97	100.00
BEG. FUND BALANCE		1,911,046.41	1,911,046.41	1,911,046.41	1,900,574.77			

REVENUE AND EXPENDITURE REPORT FOR CITY OF NEW BUFFALO

PERIOD ENDING 06/30/2021

% Fiscal Year Completed: 100.00

*NOTE: Available Balance / Pct Budget Used does not reflect amounts encumbered.

GL NUMBER	DESCRIPTION	2020-21		YTD BALANCE	END BALANCE	ACTIVITY FOR	AVAILABLE	% B DGT
		ORIGINAL BUDGET	2020-21 AMENDED BUDGET					
Fund 599 - WATER MAINT RESERVE FUND								
FUND BALANCE ADJUSTMENTS					46,790.00			
END FUND BALANCE		1,911,046.41	1,911,046.41	1,910,836.44	1,911,046.41			
Fund 703 - CURRENT TAX FUND								
Revenues								
703-000-628.000	SERVICE CHARGE	0.00	0.00	0.00	0.00	0.00	0.00	0.00
TOTAL REVENUES		0.00	0.00	0.00	0.00	0.00	0.00	0.00
Fund 703 - CURRENT TAX FUND:								
TOTAL REVENUES		0.00	0.00	0.00	0.00	0.00	0.00	0.00
TOTAL EXPENDITURES		0.00	0.00	0.00	0.00	0.00	0.00	0.00
NET OF REVENUES & EXPENDITURES		0.00	0.00	0.00	0.00	0.00	0.00	0.00
BEG. FUND BALANCE								
END FUND BALANCE								
Fund 704 - TRUST & AGENCY								
Revenues								
704-000-665.000	INTEREST EARNED	0.00	0.00	0.00	0.00	0.00	0.00	0.00
704-000-671.000	ESCROW	0.00	0.00	25,000.00	0.00	5,000.00	(25,000.00)	100.00
704-000-671.035	ESCROW - GIERCZYK	0.00	0.00	0.00	0.00	0.00	0.00	0.00
704-000-671.036	ESCROW-NB ELECTRIC	0.00	0.00	0.00	0.00	0.00	0.00	0.00
704-000-671.037	ESCROW- GIERCZYK	0.00	0.00	0.00	0.00	0.00	0.00	0.00
704-000-671.038	ESCROW-DUNESCAPE @ NB	0.00	0.00	0.00	0.00	0.00	0.00	0.00
704-000-671.039	ESCROW-LAKESHORE FOODS	0.00	0.00	0.00	0.00	0.00	0.00	0.00
704-000-671.040	ESCROW-LAKE MICH VIEW TOWNHOME	0.00	0.00	0.00	0.00	0.00	0.00	0.00
704-000-671.041	ESCROW - A REICHERT	0.00	0.00	0.00	0.00	0.00	0.00	0.00
704-000-671.042	ESCROW - A REICHERT	0.00	0.00	0.00	0.00	0.00	0.00	0.00
704-000-671.043	ESCROW - RUBINKAM	0.00	0.00	0.00	0.00	0.00	0.00	0.00
704-000-671.044	ESCROW-BARTER CONSTRUCTION	0.00	0.00	0.00	0.00	0.00	0.00	0.00
704-000-671.045	ESCROW-REICHERT	0.00	0.00	0.00	0.00	0.00	0.00	0.00
704-000-671.046	ESCROW-LAKE MICH VIEW	0.00	0.00	0.00	0.00	0.00	0.00	0.00
704-000-671.200	FIRE INSURANCE WITHHOLDING ESC	0.00	0.00	13,117.00	0.00	0.00	(13,117.00)	100.00
TOTAL REVENUES		0.00	0.00	38,117.00	0.00	5,000.00	(38,117.00)	100.00
Expenditures								
704-896-730.000	POSTAGE	0.00	0.00	0.00	0.00	0.00	0.00	0.00
704-896-821.000	ENGINEERING	0.00	0.00	0.00	0.00	0.00	0.00	0.00
704-896-826.000	LEGAL	0.00	0.00	0.00	0.00	0.00	0.00	0.00
704-896-827.000	PLANNING CONSULTANT	0.00	0.00	0.00	0.00	0.00	0.00	0.00
704-896-903.000	PRINTING & PUBLISHING	0.00	0.00	0.00	0.00	0.00	0.00	0.00
704-896-956.200	REFUNDS	0.00	0.00	0.00	0.00	0.00	0.00	0.00
704-896-964.100	ESCROW REFUNDS	0.00	0.00	0.00	0.00	0.00	0.00	0.00
TOTAL EXPENDITURES		0.00	0.00	0.00	0.00	0.00	0.00	0.00
Fund 704 - TRUST & AGENCY:								

07/13/2021 02:44 PM

User: KATE

DB: New Buffalo

REVENUE AND EXPENDITURE REPORT FOR CITY OF NEW BUFFALO

PERIOD ENDING 06/30/2021

% Fiscal Year Completed: 100.00

*NOTE: Available Balance / Pct Budget Used does not reflect amounts encumbered.

GL NUMBER	DESCRIPTION	2020-21		YTD BALANCE	END BALANCE	ACTIVITY FOR MONTH	AVAILABLE BALANCE	% BDGT USED
		ORIGINAL BUDGET	2020-21 AMENDED BUDGET					
Fund 704 - TRUST & AGENCY								
	TOTAL REVENUES	0.00	0.00	38,117.00	0.00	5,000.00	(38,117.00)	100.00
	TOTAL EXPENDITURES	0.00	0.00	0.00	0.00	0.00	0.00	0.00
	NET OF REVENUES & EXPENDITURES	<u>0.00</u>	<u>0.00</u>	<u>38,117.00</u>	<u>0.00</u>	<u>5,000.00</u>	<u>(38,117.00)</u>	<u>100.00</u>
	BEG. FUND BALANCE							
	END FUND BALANCE			38,117.00				
	TOTAL REVENUES - ALL FUNDS	7,079,701.00	7,229,976.00	7,773,951.98	7,812,452.36	463,772.23	(543,975.98)	107.52
	TOTAL EXPENDITURES - ALL FUNDS	7,808,223.00	8,521,073.00	6,460,360.21	8,191,835.65	763,750.16	2,060,712.79	75.82
	NET OF REVENUES & EXPENDITURES	<u>(728,522.00)</u>	<u>(1,291,097.00)</u>	<u>1,313,591.77</u>	<u>(379,383.29)</u>	<u>(299,977.93)</u>	<u>(2,604,688.77)</u>	<u>101.74</u>
	BEG. FUND BALANCE - ALL FUNDS	13,044,461.60	13,044,461.60	13,044,461.60	13,423,844.89			
	END FUND BALANCE - ALL FUNDS	12,315,939.60	11,753,364.60	14,358,053.37	13,044,461.60			



TO: Mayor Humphrey and the New Buffalo City Council

FROM: Darwin Watson, City Manager

DATE: May 17, 2021

RE: 2021 Michigan Department of Natural Resources (MDNR) Waterways Grant

ITEM BEFORE THE COUNCIL:

Acceptance of the 2021 Michigan Department of Natural Resources (MDNR) Waterways Grant

DISCUSSION:

The City of New Buffalo applied to the Michigan Department of Natural Resources for the Waterways Grant. The purpose of the grant is to provide funding for the Broadside Dock and Shoreline and Marina Electrical Improvements projects. The funding requested was for upgrading the electrical system at the marina and construction of the seawall for enhanced protection of the shoreline.

In July 2021, the city received notification that we were awarded the grant request in the amount of \$689,481. The grants are reimbursable and were budgeted for the 2021-2022 fiscal year.

RECOMMENDATION:

That Mayor Humphrey and the New Buffalo City Council approves the acceptance of the 2021 Waterways Grant from the Michigan Department of Natural Resources (MDNR) in the amount of \$689,481. Additionally, city staff is authorized to execute the necessary documentation to be submitted to the United State Department of Agriculture (USDA).

2021 Waterways Grants

Emergency Repair Applications

Community	Grant Request Amount	Community Share	Total Project Amount
Schoolcraft Township Big Traverse Marina emergency repairs seawall replacement (Houghton County)	\$232,750	\$12,250	\$245,000
City of Petoskey Municipal Marina emergency replacement of 30-year-old fuel storage tanks (Emmet County)	\$125,000	\$125,000	\$250,000
Emergency repair applications sub-total	\$357,750		

Non-Emergency Repair Applications

Community	Grant Request Amount	Community Share	Total Project Amount
Marquette County Big Bay Harbor master plan	\$30,000	\$30,000	\$60,000
City of Harbor Beach Municipal Marina asphalt replacement (Huron County)	\$75,400	\$76,200	\$151,600
City of Munising municipal boating access site preliminary engineering (Alger County)	\$15,500	\$15,500	\$31,000
City of Manistee Marina phase 2 dock replacement (Manistee County)	\$203,000	\$213,700	\$416,700
City of New Buffalo Marina electrical system upgrades (Berrien County)	\$189,481	\$189,481	\$378,962
Alpena County Long Lake Park boat launch reconstruction	\$226,600	\$226,600	\$453,200
Pere Marquette Township Community Access Pere Marquette River & Pere Marquette boating access site (Mason County)	\$183,000	\$250,000	\$433,000
Non-emergency repair applications sub-total	\$3,538,681.19		

Community	Grant Request Amount	Community Share	Total Project Amount
Waucedah Township boating access site upgrades (Dickinson County)	\$93,250	\$93,250	\$186,500
Village of Empire Lake Michigan Beach Park boating access site seawall and navigation light upgrades (Leelanau County)	\$40,750	\$40,750	\$81,500
City of Charlevoix Ferry Avenue boat launch skid pier replacement (Charlevoix County)	\$41,000	\$41,000	\$82,000
City of New Buffalo Marina broadside dockage and erosion Ccontrol (Berrien County)	\$500,000	\$1,486,187	\$1,986,187
City of Detroit Erma Henderson Marina engineering for marina rehabilitation (Wayne County)	\$80,000	\$80,000	\$160,000
Village of Mackinaw City Marina A dock electrical engineering (Cheboygan County)	\$12,500	\$12,500	\$25,000
Elmwood Township Phase 3A seawall and building demo (Leelanau County)	\$378,000	\$409,500	\$787,500
City of Ludington Municipal Marina Phase 3 dock and shoreline replacement (Mason County)	\$250,000	\$250,000	\$500,000
Village of L'Anse Marina improvements, pier replacement and barrier wall construction (Baraga County)	\$60,000	\$60,000	\$120,000
City of Marquette Presque Isle Marina pier removal & site improvements (Marquette County)	\$262,100	\$262,100	\$524,200
City of Detroit Erma Henderson seawall replacement and marina rehab (Wayne County)	\$300,000	\$300,000	\$600,000
Charlevoix County Whiting Park boat launch and parking area (Charlevoix County)	\$98,100	\$187,100	\$374,200
City of Boyne City F. Grant Moore Municipal Marina phase II improvements (Charlevoix County)	\$500,000	\$1,112,671	\$1,612,671
Non-emergency repair applications sub-total	\$3,538,681.19		



TO: Mayor Humphrey and the New Buffalo City Council

FROM: Darwin Watson, City Manager

DATE: May 17, 2021

RE: United State Department of Agriculture (USDA) Rural Business Development Grant

ITEM BEFORE THE COUNCIL:

Acceptance of the USDA Rural Business Development Grant

DISCUSSION:

The City of New Buffalo applied to the USDA for the Rural Business Development Grant. The purpose of the grant is to provide funding for the preliminary engineering and design work for the Marina Expansion & Shoreline Protection project.

In July 2021, the city received notification that we were awarded the grant request in the amount of \$47,900. The grant is reimbursable and was budgeted for the 2021-2022 fiscal year.

RECOMMENDATION:

That Mayor Humphrey and the New Buffalo City Council approves the acceptance of the Rural Business Development Grant from the USDA in the amount of \$47,900. Additionally, city staff is authorized to execute the necessary documentation to be submitted to the United State Department of Agriculture (USDA).

Darwin Watson

From: Tony McGhee <tmcghee@abonmarche.com>
Sent: Thursday, July 8, 2021 1:41 PM
To: Darwin Watson; John Humphrey
Cc: Kate Vyskocil; Rich Killips; Parks; Mike Morphey
Subject: Rural Business Development Grants

Follow Up Flag: Follow up
Flag Status: Flagged

You got your RDBG grant for \$47,900 to help offset the costs of preliminary engineering and permitting for the wall project. Onward!

Tony McGhee

Vice President of Development Services

☎ 269.927.2295 ext. 130

☎ 269.252.8980

abonmarche.com



"2021 Firm of the Year"

From: Joelle Regovich <jregovich@abonmarche.com>
Sent: Thursday, July 8, 2021 1:26 PM
To: Tony McGhee <tmcghee@abonmarche.com>; Tim Drews <tdrews@abonmarche.com>
Cc: Katie Saintz <ksaintz@abonmarche.com>
Subject: FW: Rural Business Development Grants - City of Allegan and City of New Buffalo

Both Allegan and New Buffalo were awarded RBDG grants. Good deal.

That means all the ones we submitted, except Bangor, were funded. We knew Bangor would be a likely no go though.

Grant App	Engineering Fees
USDA RBDG Cornerstone Parking Construction	\$ 14,545.36
USDA RBDG Farmers Market pavilion construction	\$ 8,000.00
USDA RBDG Technical Assistance – Allegan Downtown Streetscape	\$ 236,680.00
USDA RBDG Technical Assistance – Bangor Industrial Park	\$ 78,200.00
USDA RBDG Technical Assistance – New Buffalo Marina Expansion/Broadside Dock/Shoreline protection	\$ 47,900.00

USDA RBDG Technical Assistance – Berrien County Red Arrow Linear Park	\$ 150,000.00
---	---------------

Joelle

CONFIDENTIALITY NOTICE: This e-mail and any attachments are for the exclusive and confidential use of the intended recipient. If you are not the intended recipient, please do not read, distribute or take action in reliance upon this message. If you have received this e-mail in error, please notify us immediately and promptly delete this message and its attachments from your computer system. We do not waive any work product privilege by the transmission of this message.



TO: Mayor Humphrey and the New Buffalo City Council

FROM: Darwin Watson, City Manager

DATE: May 17, 2021

RE: Acceptance of Donation – Dune Walk Bench

ITEM BEFORE THE COUNCIL:

Acceptance of Donation – Dune Walk Bench

DISCUSSION:

The City of New Buffalo received notification from resident Mary Rose Denton, that she would like to donate a bench in honor of former City Manager Dave Richards. The bench would be located on the dune walk to allow for people of all abilities to enjoy the sunset and dune area of the beach.

RECOMMENDATION:

That Mayor Humphrey and the New Buffalo City Council approve the acceptance of the bench donation from Ms. Mary Rose Denton.



**MARY ROSE 3 PERSON BENCH
NEW BUFFALO DUNE WALK**

ERIC TROWBRIDGE DESIGN 4351 PINE CREEK ROAD ELKHART INDIANA 46516 574-295-8838 - 574-250-7371

ISSUE
03/24/21

DRAWN BY
ERT

PAGE NO.

1



**MARY ROSE 3 PERSON BENCH
NEW BUFFALO DUNE WALK**

ERIC TROWBRIDGE DESIGN 4351 PINE CREEK ROAD ELKHART INDIANA 46516 574-295-8838 - 574-250-7371

ISSUE
03/24/21

DRAWN BY
ERT

PAGE NO.

2

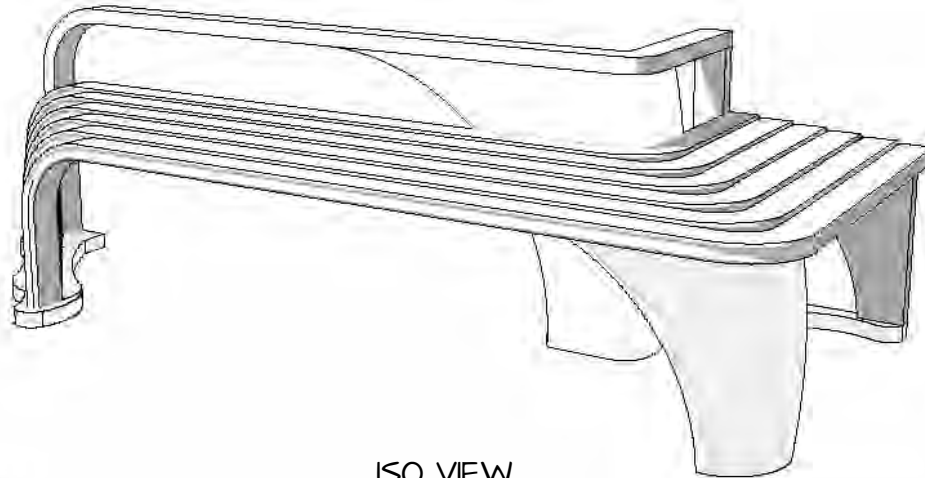

ISO VIEW

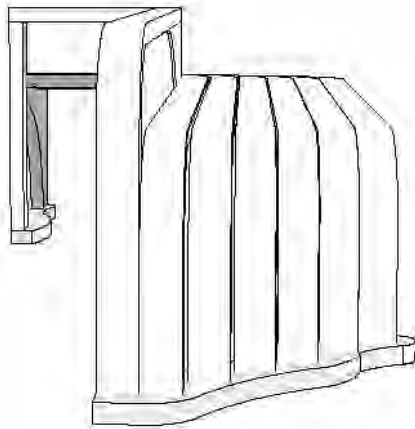

LEFT

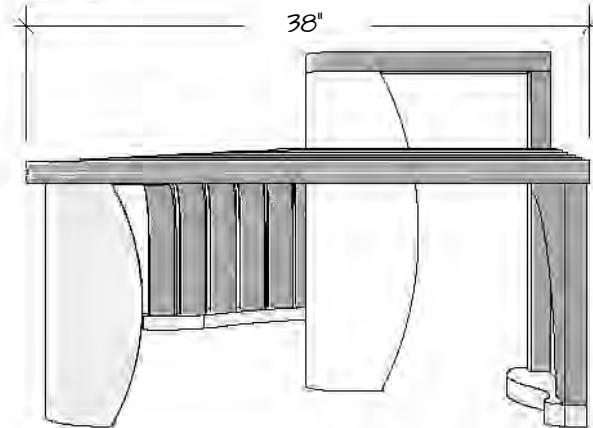

38"

RIGHT

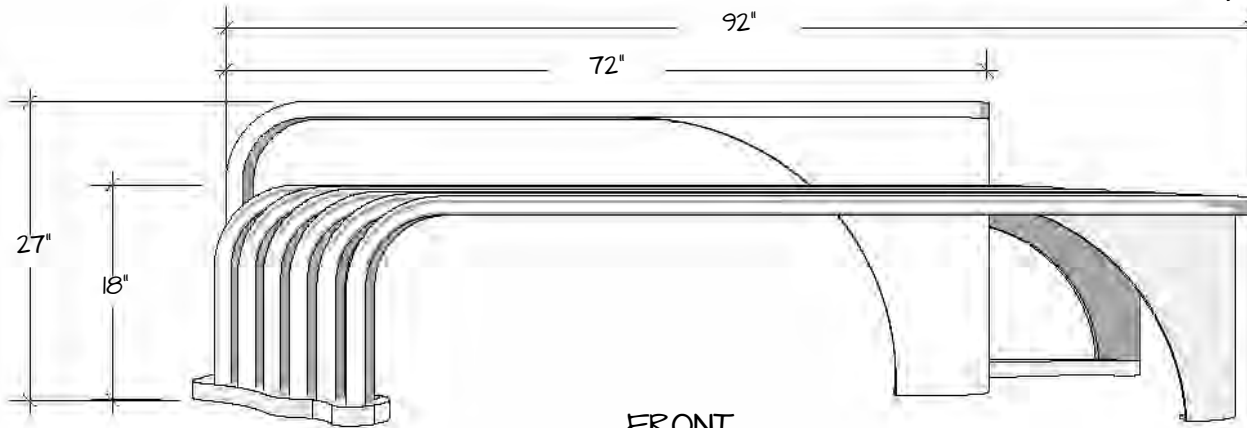

FRONT

92"

72"

27"

18"



**MARY ROSE 3 PERSON BENCH
NEW BUFFALO DUNE WALK**

ERIC TROWBRIDGE DESIGN 4351 PINE CREEK ROAD ELKHART INDIANA 46516 574-295-8838 - 574-250-7371

ISSUE
03/24/21

DRAWN BY
ERT

PAGE NO.
3

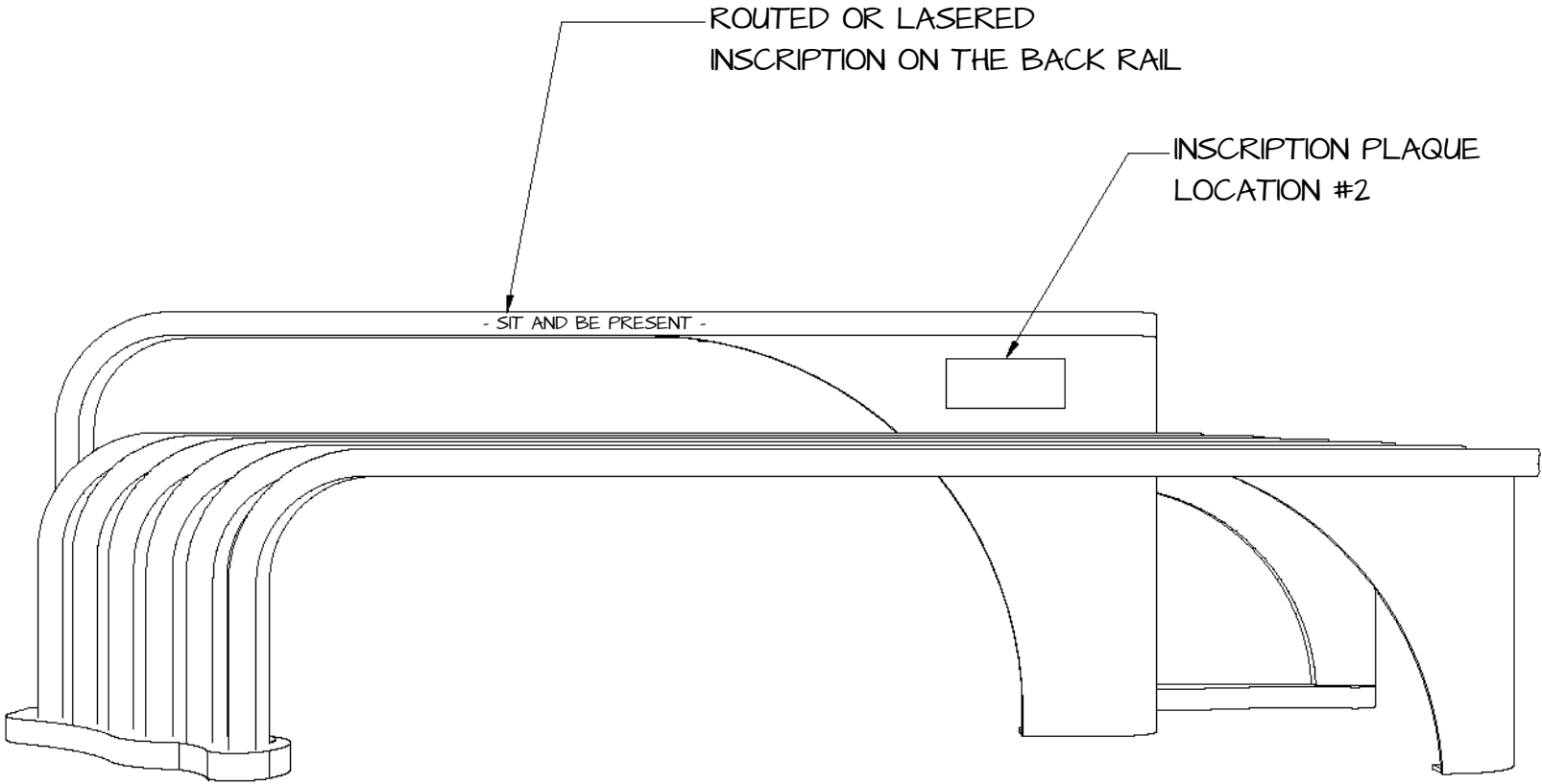

INSCRIPTION LOCATION OPTIONS



**MARY ROSE 3 PERSON BENCH
NEW BUFFALO DUNE WALK**

ERIC TROWBRIDGE DESIGN 4351 PINE CREEK ROAD ELKHART INDIANA 46516 574-295-8838 - 574-250-7371

ISSUE
03/24/21

DRAWN BY
ERT

PAGE NO.

4

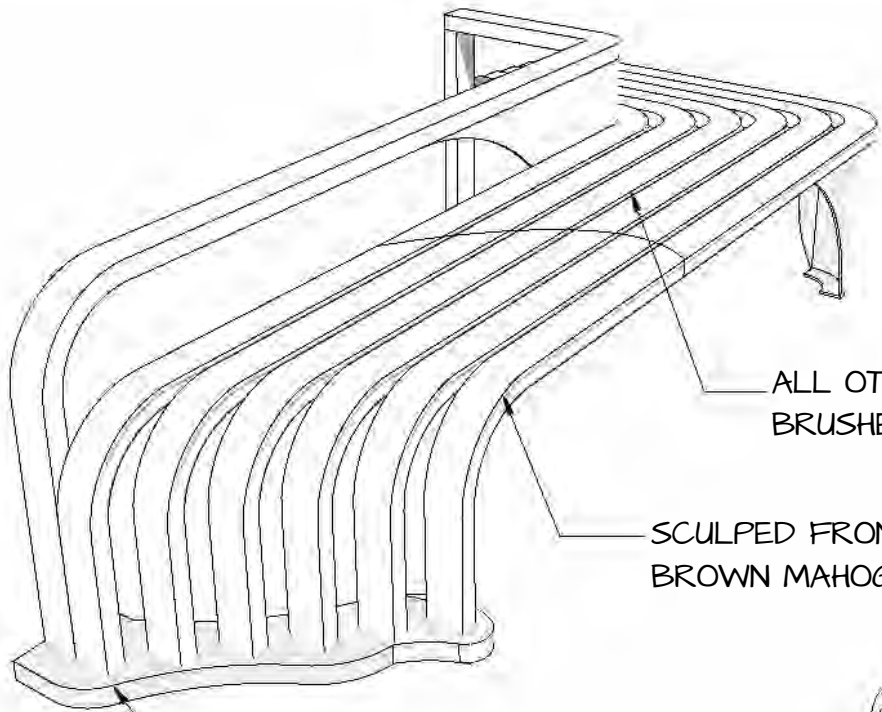

ALL OTHER SLATS
BRUSHED WHITE OAK

SCULPED FRONT SLAT
BROWN MAHOGANY

WELDED STEEL BASE
WITH BLUE DISTRESSED
RUST FINISH

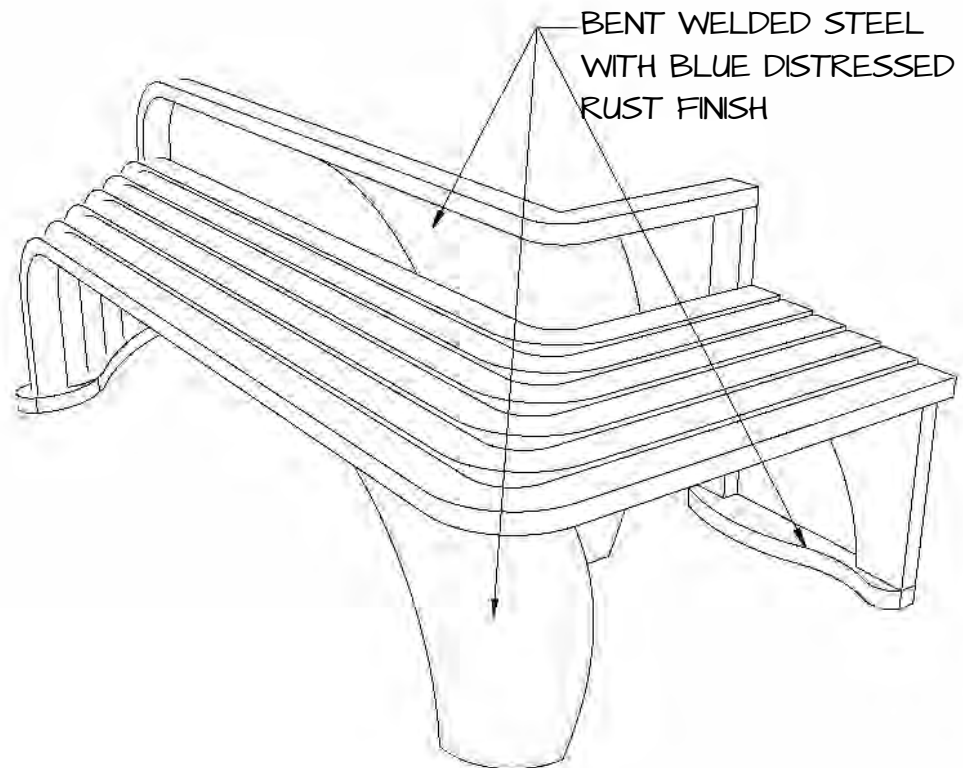

BENT WELDED STEEL
WITH BLUE DISTRESSED
RUST FINISH

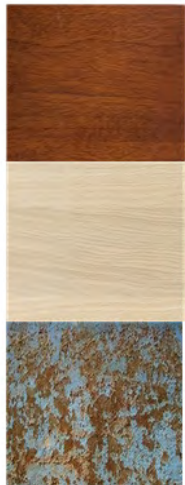

MAHOGANY

WHITE OAK

BLUE GREEN
RUSTED STEEL



**MARY ROSE 3 PERSON BENCH
NEW BUFFALO DUNE WALK**

ERIC TROWBRIDGE DESIGN 4351 PINE CREEK ROAD ELKHART INDIANA 46516 574-295-8888 - 574-250-7371

ISSUE
03/24/21

DRAWN BY
ERT

PAGE NO.

5

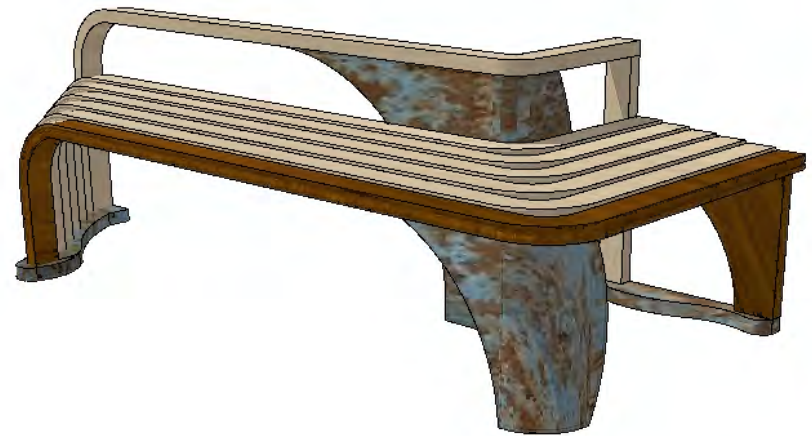
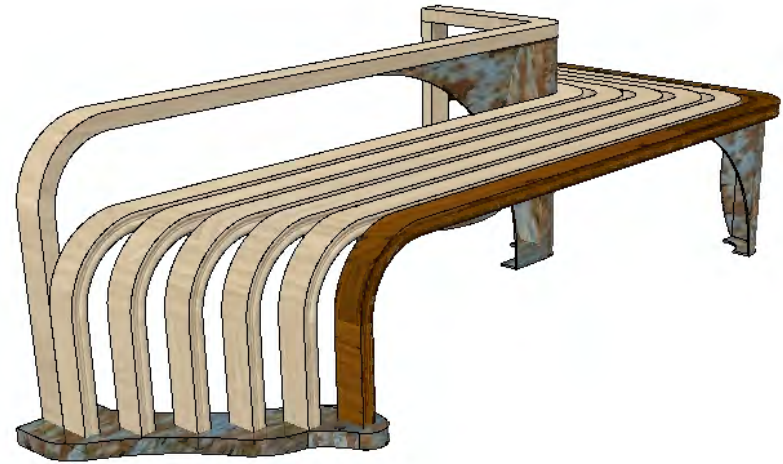
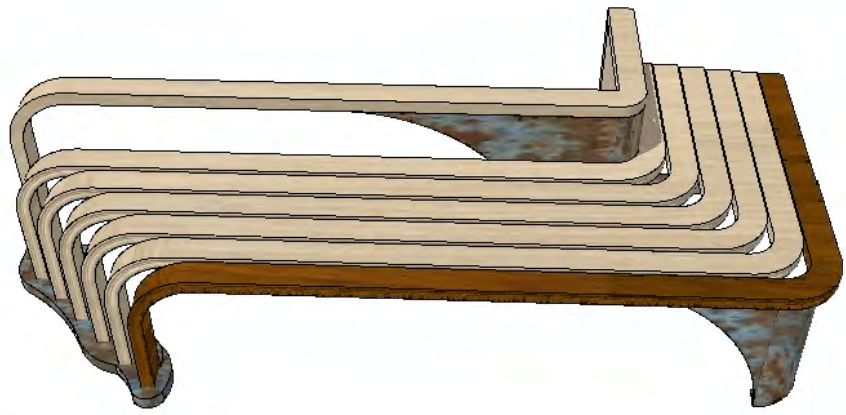

Darwin Watson

From: gooddecisiondogtraining <gooddecisiondogtraining@gmail.com>
Sent: Thursday, July 8, 2021 12:10 PM
To: Darwin Watson
Cc: Parks; Amy Fidler; John Humphrey
Subject: Bench donation to honor city manager, design attached
Attachments: MR DUNE BENCH_FINAL.pdf

Hello. My name is Mary Rose Denton. I would like to submit this proposal to donate a bench for the Dune Walk in honor of the city manager. I wanted it to be art (something visitors will want to photograph) and function so people of all abilities can enjoy a Michigan sunset.

Once approved by you, I will sign the contract with delivery expected October 1. Eric has family in the area and is happily doing this for us basically for cost.

Thanks!/
Mary Rose

Sent from my T-Mobile 4G LTE Device

----- Original message -----

From: Eric Trowbridge <eric@erictrowbridge.com>
Date: 7/7/21 8:35 PM (GMT-06:00)
To: GoodDecisionDogTraining@gmail.com
Subject:

Mary,
Attached you will find the contract, invoice, and drawings for the 3 person bench for the New Buffalo ADA Dune Walk. Please review them in detail and let me know if you have any questions or concerns. After your review sign the contract and send it back to us via email or regular USPS mail. We have also sent an electronic invoice to you via email if you choose to pay the deposit via ACH or Credit Card. Otherwise please send a check for the deposit to our Elkhart address. Once your deposit is received we will officially put your project into the schedule and give you a start date for the project. Thank you again for the opportunity to be a part of this project we are looking forward to working with you.

Best regards,
Eric Trowbridge

--

Eric Trowbridge Design LLC.
4351 Pine Creek Road
Elkhart IN, 46516

Phone / Fax 574-295-8838
Mobile 574-250-7371
eric@erictrowbridge.com
www.erictrowbridge.com

--

Eric Trowbridge Design LLC.
4351 Pine Creek Road
Elkhart IN, 46516

Phone / Fax 574-295-8838
Mobile 574-250-7371
eric@erictrowbridge.com
www.erictrowbridge.com



TO: Mayor Humphrey and the New Buffalo City Council

FROM: Darwin Watson, City Manager

DATE: July 19, 2021

RE: 2021 Street Resurfacing Project Award

ITEM BEFORE THE COUNCIL:

Approval of the award to Kalin Construction for the 2021 Street Resurfacing Project Award

DISCUSSION:

On April 19, 2021, the City of New Buffalo approved the professional services for the 2021 New Buffalo Paving project. This approval included several phases, one of which was the letting of the bids. On June 16, 2021, the city opened the construction bids received for the resurfacing project. Bids were received from Kalin Construction, Michigan Paving and Rieth Riley Construction.

The low bid was submitted by Kalin Construction in the amount of \$201,064.25. This project was budgeted in the 2021-2022 fiscal year budget.

RECOMMENDATION:

That Mayor Humphrey and the New Buffalo City Council approve the awarding of the contract for street resurfacing to Kalin Construction in the amount of \$201,064.25.

June 21, 2021

Darwin Watson, City Manager
City of New Buffalo
224 W. Buffalo St
New Buffalo, MI 49117

**RE: New Buffalo 2021 Street Resurfacing Project
Recommendation for Award**

Dear Mr. Watson:

On Wednesday, June 16, 2021, at 11:00 a.m., the City of New Buffalo received two (3) bids for the New Buffalo Street Resurfacing Project. Bids were opened at City Hall and contained all the required submittals, including the Bid Security and Legal Status.

Abonmarche has previous working experience with all 3 bidders and we believe the contractors are qualified and capable of the work required for the scope of the project. A summary of the attached bid tabulation is provided below.

BID SUMMARY:

BASE BID

Prepared By:	Total Amount
Kalin Construction Co., Inc.	\$201,064.25
Michigan Paving and Materials Co.	\$220,444.00
Rieth Riley Construction Co., Inc.	\$265,729.00

*Reflects corrected total (see below)

RECOMMENDATION

After review of the bids received, Abonmarche has found all bidders to be qualified and their bids are properly prepared. We believe that the bids are competitive and reflective of the current market.

Therefore, Abonmarche recommends that the City of New Buffalo award the project to **Kalin Construction Co., Inc.** for a total contract amount of **\$201,064.25.**

Please feel free to contact us at our office if you have any questions or comments.

Sincerely,
ABONMARCHE CONSULTANTS, INC.



Jason W. Marquardt, PE
Senior Project Manager

cc: Amy Fidler, City Clerk
Kate Vyskocil, City Treasurer
Rich Killips, Police Chief
Josh Bolton, Street Department
Eric Kamps
Tony McGhee

Attachments:

- New Buffalo 2021 Street Resurfacing Bid Tabulation
- Kalin Construction Submitted Bid



Owner: City of New Buffalo
 Project Name: 2021 Street Resurfacing Project
 Project Number: 21-0751
 Date and Time: Wednesday, June 16, 2021 at 11:00 am

Legend:

Low Bidder
<i>Correction</i>

Bid Tabulation: 2021 Street Resurfacing Project

Base Bid

Item	Unit	Estimated Quantity	Engineer's Estimate		Kalin Construction		Michigan Paving & Materials		Rieth-Riley	
			Unit Price	Total	Unit Price	Total	Unit Price	Total	Unit Price	Total
1 Mobilization, Max \$13,000	LSUM	1	\$ 13,000.00	\$ 13,000.00	\$ 11,784.00	\$ 11,784.00	\$ 13,000.00	\$ 13,000.00	\$ 13,000.00	\$ 13,000.00
2 Traffic Control, Indiana St (Whittaker St to Norton St)	LSUM	1	\$ 2,500.00	\$ 2,500.00	\$ 4,995.00	\$ 4,995.00	\$ 6,500.00	\$ 6,500.00	\$ 24,000.00	\$ 24,000.00
3 Traffic Control, Indiana St (Willard St to Mayhew St)	LSUM	1	\$ 1,000.00	\$ 1,000.00	\$ 2,650.00	\$ 2,650.00	\$ 4,150.00	\$ 4,150.00	\$ 24,000.00	\$ 24,000.00
4 Traffic Control, Griffith St/Michigan St	LSUM	1	\$ 2,500.00	\$ 2,500.00	\$ 2,550.00	\$ 2,550.00	\$ 4,050.00	\$ 4,050.00	\$ 24,000.00	\$ 24,000.00
5 Subgrade Undercutting, Type IV	Cyd	100	\$ 17.50	\$ 1,750.00	\$ 15.00	\$ 1,500.00	\$ 50.00	\$ 5,000.00	\$ 20.00	\$ 2,000.00
6 Excavation, Earth	Cyd	35	\$ 7.50	\$ 262.50	\$ 15.00	\$ 525.00	\$ 35.00	\$ 1,225.00	\$ 30.00	\$ 1,050.00
7 Aggregate Base, LM	Cyd	100	\$ 25.00	\$ 2,500.00	\$ 27.00	\$ 2,700.00	\$ 31.50	\$ 3,150.00	\$ 25.00	\$ 2,500.00
8 Erosion Control, Inlet Protection, Fabric Drop	Ea	12	\$ 100.00	\$ 1,200.00	\$ 100.00	\$ 1,200.00	\$ 50.00	\$ 600.00	\$ 175.00	\$ 2,100.00
9 Aggregate Base, Conditioning	Syd	7055	\$ 2.50	\$ 17,637.50	\$ 1.25	\$ 8,818.75	\$ 1.00	\$ 7,055.00	\$ 1.00	\$ 7,055.00
10 Dr Structure Cover, Adj, Case 1	Ea	9	\$ 550.00	\$ 4,950.00	\$ 590.00	\$ 5,310.00	\$ 500.00	\$ 4,500.00	\$ 375.00	\$ 3,375.00
11 Dr Structure Cover, Type Q, Modified	Ea	6	\$ 600.00	\$ 3,600.00	\$ 542.00	\$ 3,252.00	\$ 1,500.00	\$ 9,000.00	\$ 800.00	\$ 4,800.00
12 Dr Structure Cover, Type EJ #1040 M1	Ea	3	\$ 600.00	\$ 1,800.00	\$ 575.00	\$ 1,725.00	\$ 600.00	\$ 1,800.00	\$ 800.00	\$ 2,400.00
13 Cold Milling HMA Surface	Syd	7055	\$ 3.00	\$ 21,165.00	\$ 1.90	\$ 13,404.50	\$ 3.00	\$ 21,165.00	\$ 4.80	\$ 33,864.00
14 HMA, 13A	Ton	830	\$ 75.00	\$ 62,250.00	\$ 84.00	\$ 69,720.00	\$ 87.80	\$ 72,874.00	\$ 73.00	\$ 60,590.00
15 HMA, 36A	Ton	625	\$ 85.00	\$ 53,125.00	\$ 104.00	\$ 65,000.00	\$ 87.80	\$ 54,875.00	\$ 88.20	\$ 55,125.00
16 Pavt Mrkg, Ovly Cold Plastic, 12 inch Crosswalk	Ft	110	\$ 6.50	\$ 715.00	\$ 11.00	\$ 1,210.00	\$ 20.00	\$ 2,200.00	\$ 8.00	\$ 880.00
17 Gate Box, Adj, Case 1	Ea	6	\$ 450.00	\$ 2,700.00	\$ 280.00	\$ 1,680.00	\$ 600.00	\$ 3,600.00	\$ 325.00	\$ 1,950.00
18 Slope Restoration, Type A	Syd	760	\$ 5.00	\$ 3,800.00	\$ 4.00	\$ 3,040.00	\$ 7.50	\$ 5,700.00	\$ 4.00	\$ 3,040.00
Base Bid Total			\$ 196,455.00		\$ 201,064.25		\$ 220,444.00		\$ 265,729.00	
Bid Statistics			% of Estimate	100.00%	% of Estimate	102.35%	% of Estimate	112.21%	% of Estimate	135.26%
			% of Low Bid	97.71%	% of Low Bid	100.00%	% of Low Bid	109.64%	% of Low Bid	132.16%

Alternate Bid

Item	Unit	Estimated Quantity	Engineer's Estimate		Kalin Construction		Michigan Paving & Materials		Rieth-Riley	
			Unit Price	Total	Unit Price	Total	Unit Price	Total	Unit Price	Total
1 Guardrail, Rem	Ft	304	\$ 10.00	\$ 3,040.00	\$ 1.00	\$ 304.00	\$ 1.00	\$ 304.00	\$ 1.00	\$ 304.00
2 Guardrail, Type MGS-8	LSUM	88	\$ 22.50	\$ 1,980.00	\$ 25.00	\$ 2,200.00	\$ 25.00	\$ 2,200.00	\$ 25.00	\$ 2,200.00
3 Guardrail, Curved, Type MGS-8	LSUM	38	\$ 25.00	\$ 950.00	\$ 25.00	\$ 950.00	\$ 25.00	\$ 950.00	\$ 25.00	\$ 950.00
4 Guardrail Approach Terminal, Type 2M	LSUM	6	\$ 3,000.00	\$ 18,000.00	\$ 2,800.00	\$ 16,800.00	\$ 3,217.00	\$ 19,302.00	\$ 2,800.00	\$ 16,800.00
5 Guardrail Reflector	Cyd	8	\$ 7.50	\$ 60.00	\$ 5.00	\$ 40.00	\$ 5.00	\$ 40.00	\$ 5.00	\$ 40.00
Alternate Bid Total			\$ 24,030.00		\$ 20,294.00		\$ 22,796.00		\$ 20,294.00	
Bid Statistics			% of Estimate	100.00%	% of Estimate	84.45%	% of Estimate	94.86%	% of Estimate	84.45%
			% of Low Bid	118.41%	% of Low Bid	100.00%	% of Low Bid	112.33%	% of Low Bid	100.00%

SECTION 00 41 43
BID FORM (SINGLE PRIME – UNIT PRICE)

The terms used in this Bid with initial capital letters have the meanings stated in the Instructions to Bidders, the General Conditions, and the Supplementary Conditions.

ARTICLE 1—OWNER AND BIDDER

1.01 This Bid is submitted to:

- A. Amy Fidler
City Clerk
224 W Buffalo St
New Buffalo, MI 49117

1.02 The undersigned Bidder proposes and agrees, if this Bid is accepted, to enter into an Agreement with Owner in the form included in the Bidding Documents to perform all Work as specified or indicated in the Bidding Documents for the prices and within the times indicated in this Bid and in accordance with the other terms and conditions of the Bidding Documents.

ARTICLE 2—ATTACHMENTS TO THIS BID

2.01 The following documents are submitted with and made a condition of this Bid:

- A. Required Bid security;
- B. Evidence of authority to do business in the state of the Project; or a written covenant to obtain such authority within the time for acceptance of Bids;
- C. Contractor’s license number as evidence of Bidder’s State Contractor’s License or a covenant by Bidder to obtain said license within the time for acceptance of Bids;

ARTICLE 3—BASIS OF BID—UNIT PRICES

3.01 *Unit Price Bids*

- A. Bidder will perform the following Work at the indicated unit prices:

BASE BID

Item No.	Description	Unit	Estimated Quantity	Unit Price	Bid Amount
1	Mobilization, Max \$13,000	LSUM	1	\$ 11,784	\$ 11,784
2	Traffic Control, Indiana St (Whittaker St to Norton St)	LSUM	1	\$ 4,995	\$ 4,995
3	Traffic Control, Indiana St (Willard St to Mayhew St)	LSUM	1	\$ 2,650	\$ 2,650
4	Traffic Control, Griffith St/Michigan St	LSUM	1	\$ 2,550	\$ 2,550
5	Subgrade Undercutting, Type IV	Cyd	100	\$ 15.00	\$ 1,500

6	Excavation, Earth	Cyd	35	\$ 15.00	\$ 525.00
7	Aggregate Base, LM	Cyd	100	\$ 27.00	\$ 2,700.00
8	Erosion Control, Inlet Protection, Fabric Drop	Ea	12	\$ 100.00	\$ 1,200.00
9	Aggregate Base, Conditioning	Syd	7055	\$ 1.25	\$ 8,818.75
10	Dr Structure Cover, Adj, Case 1	Ea	9	\$ 590.00	\$ 5,310.00
11	Dr Structure Cover, Type Q, Modified	Ea	6	\$ 542.00	\$ 3,252.00
12	Dr Structure Cover, Type EJ #1040 M1	Ea	3	\$ 575.00	\$ 1,725.00
13	Cold Milling HMA Surface	Syd	7055	\$ 1.90	\$ 13,404.50
14	HMA, 13A	Ton	830	\$ 84.00	\$ 69,720.00
15	HMA, 36A	Ton	625	\$ 104.00	\$ 65,000.00
16	Pavt Mrkg, Ovly Cold Plastic, 12 inch Crosswalk	Ft	110	\$ 11.00	\$ 1,210.00
17	Gate Box, Adj, Case 1	Ea	6	\$ 280.00	\$ 1,680.00
18	Slope Restoration, Type A	Syd	760	\$ 4.00	\$ 3,040.00
Total of All Unit Price Base Bid Items					\$ 201,064.25
Anticipated Construction Start Date			9-7-21		

ALTERNATE BID

Item No.	Description	Unit	Estimated Quantity	Unit Price	Bid Amount
1	Guardrail, Rem	Ft	304	\$ 1.00	\$ 304.00
2	Guardrail, Type MGS-8	Ft	88	\$ 25.00	\$ 2,200.00
3	Guardrail, Curved, Type MGS-8	Ft	38	\$ 25.00	\$ 950.00
4	Guardrail Approach Terminal, Type 2M	Ea	6	\$ 2,800.00	\$ 16,800.00
5	Guardrail Reflector	Ea	8	\$ 5.00	\$ 40.00
Total of All Unit Price Alternate Bid Items					\$ 20,294.00

B. Bidder acknowledges that:

1. each Bid Unit Price includes an amount considered by Bidder to be adequate to cover Contractor's overhead and profit for each separately identified item, and
2. estimated quantities are not guaranteed, and are solely for the purpose of comparison of Bids, and final payment for all Unit Price Work will be based on actual quantities, determined as provided in the Contract Documents.

ARTICLE 4—TIME OF COMPLETION

- 4.01 Bidder agrees that the Work will be fully completed and ready for final payment in accordance with Paragraph 15.06 of the General Conditions by within **Thirty (30) calendar days (excluding weekends) from the commencement of construction.** Construction must be completed by **October 22, 2021.**
- 4.02 Bidder accepts the provisions of the Agreement as to liquidated damages.

ARTICLE 5—BIDDER’S ACKNOWLEDGEMENTS: ACCEPTANCE PERIOD, INSTRUCTIONS, AND RECEIPT OF ADDENDA

5.01 *Bid Acceptance Period*

- A. This Bid will remain subject to acceptance for 60 days after the Bid opening, or for such longer period of time that Bidder may agree to in writing upon request of Owner.

5.02 *Instructions to Bidders*

- A. Bidder accepts all of the terms and conditions of the Instructions to Bidders, including without limitation those dealing with the disposition of Bid security.

5.03 *Receipt of Addenda*

- A. Bidder hereby acknowledges receipt of the following Addenda:

Addendum Number	Addendum Date

ARTICLE 6—BIDDER’S REPRESENTATIONS AND CERTIFICATIONS

6.01 *Bidder’s Representations*

- A. In submitting this Bid, Bidder represents the following:
 1. Bidder has examined and carefully studied the Bidding Documents, including Addenda.
 2. Bidder has visited the Site, conducted a thorough visual examination of the Site and adjacent areas, and become familiar with the general, local, and Site conditions that may affect cost, progress, and performance of the Work.
 3. Bidder is familiar with all Laws and Regulations that may affect cost, progress, and performance of the Work.
 4. Bidder has carefully studied the reports of explorations and tests of subsurface conditions at or adjacent to the Site and the drawings of physical conditions relating to existing surface or subsurface structures at the Site that have been identified in the Supplementary Conditions, with respect to the Technical Data in such reports and drawings.
 5. Bidder has carefully studied the reports and drawings relating to Hazardous Environmental Conditions, if any, at or adjacent to the Site that have been identified in the Supplementary Conditions, with respect to Technical Data in such reports and drawings.
 6. Bidder has considered the information known to Bidder itself; information commonly known to contractors doing business in the locality of the Site; information and observations obtained from visits to the Site; the Bidding Documents; and the Technical Data identified in the Supplementary Conditions or by definition, with respect to the effect of such information, observations, and Technical Data on (a) the cost, progress, and performance of the Work; (b) the means, methods, techniques, sequences, and

procedures of construction to be employed by Bidder, if selected as Contractor; and (c) Bidder's (Contractor's) safety precautions and programs.

7. Based on the information and observations referred to in the preceding paragraph, Bidder agrees that no further examinations, investigations, explorations, tests, studies, or data are necessary for the performance of the Work at the Contract Price, within the Contract Times, and in accordance with the other terms and conditions of the Contract.
8. Bidder is aware of the general nature of work to be performed by Owner and others at the Site that relates to the Work as indicated in the Bidding Documents.
9. Bidder has given Engineer written notice of all conflicts, errors, ambiguities, or discrepancies that Bidder has discovered in the Bidding Documents, and of discrepancies between Site conditions and the Contract Documents, and the written resolution thereof by Engineer is acceptable to Contractor.
10. The Bidding Documents are generally sufficient to indicate and convey understanding of all terms and conditions for performance and furnishing of the Work.
11. The submission of this Bid constitutes an incontrovertible representation by Bidder that without exception the Bid and all prices in the Bid are premised upon performing and furnishing the Work required by the Bidding Documents.

6.02 *Bidder's Certifications*

A. The Bidder certifies the following:

1. This Bid is genuine and not made in the interest of or on behalf of any undisclosed individual or entity and is not submitted in conformity with any collusive agreement or rules of any group, association, organization, or corporation.
2. Bidder has not directly or indirectly induced or solicited any other Bidder to submit a false or sham Bid.
3. Bidder has not solicited or induced any individual or entity to refrain from bidding.
4. Bidder has not engaged in corrupt, fraudulent, collusive, or coercive practices in competing for the Contract. For the purposes of this Paragraph 8.02.A:
 - a. Corrupt practice means the offering, giving, receiving, or soliciting of anything of value likely to influence the action of a public official in the bidding process.
 - b. Fraudulent practice means an intentional misrepresentation of facts made (a) to influence the bidding process to the detriment of Owner, (b) to establish bid prices at artificial non-competitive levels, or (c) to deprive Owner of the benefits of free and open competition.
 - c. Collusive practice means a scheme or arrangement between two or more Bidders, with or without the knowledge of Owner, a purpose of which is to establish bid prices at artificial, non-competitive levels.
 - d. Coercive practice means harming or threatening to harm, directly or indirectly, persons or their property to influence their participation in the bidding process or affect the execution of the Contract.

BIDDER hereby submits this Bid as set forth above:

Bidder: Kalin Construction Co., Inc.
(typed or printed name of organization)

By: *Michael Kalin*
(individual's signature)

Name: Michael Kalin
(typed or printed)

Title: Owner / Proj. Mgr.
(typed or printed)

Date: 6-16-21
(typed or printed)

If Bidder is a corporation, a partnership, or a joint venture, attach evidence of authority to sign.

Attest: _____
(individual's signature)

Name: _____
(typed or printed)

Title: _____
(typed or printed)

Date: _____
(typed or printed)

Address for giving notices:

Bidder's Contact:
 Name: Michael Kalin
(typed or printed)

Title: Proj. Mgr.
(typed or printed)

Phone: 269-925-2746

Email: MKalin@Kalininc.com

Address: 2663 Yorc Ave.
Sodus, MI 49126

Bidder's Contractor License No.: (if applicable) _____

SECTION 00 45 19
NON-COLLUSION AFFIDAVIT

STATE OF Michigan
COUNTY OF Berrien

The undersigned bidder or agent, being duly sworn, on oath says that he will not, nor will any other member, representative, or agent of the firm, company, corporation, or partnership represented by him, entered into any combination, collusion or agreement with any person relative to the price to be bid by anyone at such letting, nor to prevent any person from bidding nor to induce anyone to refrain from bidding, and that his bid is made without reference to any other bid and without any agreement, understanding, or combination with any other person in reference to such bidding in any way or manner whatever.

[Signature]
Signature of Bidder or Agent

Michael Kalin
Print Name

Proj. Mgr.
Position

For: Kalin Construction Co., Inc.
Name of Firm

Subscribed and sworn to before me this 16th day of June, 2021.

My commission expires: 10-03-21
[Signature]
Notary Public



END OF SECTION

AIA Document A310™ – 2010

Bid Bond

CONTRACTOR:

(Name, legal status and address)

Kalm Construction Co., Inc.

2663 Yore Avenue

Sodus, MI 49126

SURETY:

(Name, legal status and principal place of business)

Western Surety Company

151 N. Franklin Street

Chicago, IL 60606

This document has important legal consequences. Consultation with an attorney is encouraged with respect to its completion or modification.

Any singular reference to Contractor, Surety, Owner or other party shall be considered plural where applicable.

OWNER:

(Name, legal status and address)

City of New Buffalo

BOND AMOUNT: Five Percent of Bid (5% of Bid)

PROJECT:

2021 street Resurfacing Project

(Name, location or address, and Project number, if any)

The Contractor and Surety are bound to the Owner in the amount set forth above, for the payment of which the Contractor and Surety bind themselves, their heirs, executors, administrators, successors and assigns, jointly and severally, as provided herein. The conditions of this Bond are such that if the Owner accepts the bid of the Contractor within the time specified in the bid documents, **or** within such time period as may be agreed to by the Owner and Contractor, and the Contractor either (1) enters into a contract with the Owner in accordance with the terms of such bid, and gives such bond or bonds as may be specified in the bidding or Contract Documents, with a surety admitted in the jurisdiction of the Project and otherwise acceptable to the Owner, for the faithful performance of such Contract and for the prompt payment of labor and material furnished in the prosecution thereof; or (2) pays to the Owner the difference, not to exceed the amount of this Bond, between the amount specified in said bid and such larger amount for which the Owner may in good faith contract with another party to perform the work covered by said bid, then this obligation shall be null and void, otherwise to remain in full force and effect. The Surety hereby waives any notice of an agreement between the Owner and Contractor to extend the time in which the Owner may accept the bid. Waiver of notice by the Surety shall not apply to any extension exceeding sixty (60) days in the aggregate beyond the time for acceptance of bids specified in the bid documents, and the Owner and Contractor shall obtain the Surety's consent for an extension beyond sixty (60) days.

If this Bond is issued in connection with a subcontractor's bid to a Contractor, the term Contractor in this Bond shall be deemed to be Subcontractor and the term Owner shall be deemed to be Contractor.

When this Bond has been furnished to comply with a statutory or other legal requirement in the location of the Project, any provision in this Bond conflicting with said statutory or legal requirement shall be deemed deleted herefrom and provisions conforming to such statutory or other legal requirement shall be deemed incorporated herein. When so furnished, the intent is that this Bond shall be construed as a statutory bond and not as a common law bond.

Signed and sealed this 16th day of June, 2021



(Witness)



(Witness) Heather Buonodono

Kalm Construction Co., Inc.
(Principal)  (Seal)

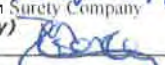
(Title) Prof. Mgr.
Western Surety Company
(Surety)  (Seal)

(Title) Dan Cusenza, Attorney-in-Fact

Western Surety Company

POWER OF ATTORNEY APPOINTING INDIVIDUAL ATTORNEY-IN-FACT

Know All Men By These Presents, That WESTERN SURETY COMPANY, a South Dakota corporation, is a duly organized and existing corporation having its principal office in the City of Sioux Falls, and State of South Dakota, and that it does by virtue of the signature and seal herein affixed hereby make, constitute and appoint

John T Foster, Jim Slear, Dan Cusenza, Heather Buonodono, Individually

of Lansing, MI, its true and lawful Attorney(s)-in-Fact with full power and authority hereby conferred to sign, seal and execute for and on its behalf bonds, undertakings and other obligatory instruments of similar nature

- In Unlimited Amounts -

and to bind it thereby as fully and to the same extent as if such instruments were signed by a duly authorized officer of the corporation and all the acts of said Attorney, pursuant to the authority hereby given, are hereby ratified and confirmed.

This Power of Attorney is made and executed pursuant to and by authority of the By-Law printed on the reverse hereof, duly adopted, as indicated, by the shareholders of the corporation.

In Witness Whereof, WESTERN SURETY COMPANY has caused these presents to be signed by its Vice President and its corporate seal to be hereto affixed on this 15th day of March, 2018.



WESTERN SURETY COMPANY

Paul T. Bruffat

Paul T. Bruffat, Vice President

State of South Dakota }
County of Minnehaha } ss

On this 15th day of March, 2018, before me personally came Paul T. Bruffat, to me known, who, being by me duly sworn, did depose and say: that he resides in the City of Sioux Falls, State of South Dakota; that he is the Vice President of WESTERN SURETY COMPANY described in and which executed the above instrument; that he knows the seal of said corporation; that the seal affixed to the said instrument is such corporate seal; that it was so affixed pursuant to authority given by the Board of Directors of said corporation and that he signed his name thereto pursuant to like authority, and acknowledges same to be the act and deed of said corporation.

My commission expires

June 23, 2021

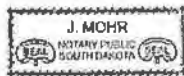

J. Mohr

J. Mohr, Notary Public

CERTIFICATE

I, L. Nelson, Assistant Secretary of WESTERN SURETY COMPANY do hereby certify that the Power of Attorney hereinabove set forth is still in force, and further certify that the By-Law of the corporation printed on the reverse hereof is still in force. In testimony whereof I have hereunto subscribed my name and affixed the seal of the said corporation this 16th day of June, 2021.



WESTERN SURETY COMPANY

L. Nelson

L. Nelson, Assistant Secretary

Form 14280 7-2012

Go to www.cnasurety.com > Owner / Oblige Services > Validate Bond Coverage, if you want to verify bond authenticity.

Authorizing By-Law

ADOPTED BY THE SHAREHOLDERS OF WESTERN SURETY COMPANY

This Power of Attorney is made and executed pursuant to and by authority of the following By-Law duly adopted by the shareholders of the Company.

Section 7. All bonds, policies, undertakings, Powers of Attorney, or other obligations of the corporation shall be executed in the corporate name of the Company by the President, Secretary, and Assistant Secretary, Treasurer, or any Vice President, or by such other officers as the Board of Directors may authorize. The President, any Vice President, Secretary, any Assistant Secretary, or the Treasurer may appoint Attorneys in Fact or agents who shall have authority to issue bonds, policies, or undertakings in the name of the Company. The corporate seal is not necessary for the validity of any bonds, policies, undertakings, Powers of Attorney or other obligations of the corporation. The signature of any such officer and the corporate seal may be printed by facsimile.

March 30, 2021

Mr. Rich Killips, Interim City Manager
City of New Buffalo
224 W Buffalo Street
New Buffalo, Michigan 49117

RE: Proposal for Professional Services – 2021 New Buffalo Paving Project

Dear Mr. Killips:

Abonmarche is pleased to present this proposal for Engineering Services related to the 2021 Street Resurfacing Program. We have reviewed the preliminary scope of work identified for the proposed 2021 streets and understand that the project will be completed with local funds and will include asphalt resurfacing. The project will not include any underground work (water main, sanitary sewer, storm sewer, etc.). Abonmarche has recently completed similar resurfacing projects and is familiar with the design and construction administration efforts needed to successfully complete this project. The following will detail our understanding of the project, scope of services and fees.

SCOPE OF SERVICES

The New Buffalo paving project will include milling and resurfacing the existing asphalt pavement on the following streets:

Street Segment	Beginning Street	Ending Street
Indiana Street	Whittaker Street	Norton Street
Indiana Street	Willard Street	Mayhew Street
Michigan Street	Griffith Street	Franklin Street
Griffith Street	Buffalo Street	Michigan Street

The budget for construction has been established at \$174,000. The work is planned to be completed in the summer of 2021. We expect that the timeframe for construction will be flexible to include a window of available time to complete the work. This should lead to more favorable pricing. The following information details our approach to assisting the City with the successful completion of the project.

Preliminary/Final Design

1. A pavement coring will be completed to supplement existing coring data for each street in the project area to determine the existing pavement sections and to help guide design of the improvements.
2. Development of recommended pavement rehabilitation cross-sections. This will include meeting with the City to review alternatives for each street.

3. Log plan sheets including title sheet, details, cross-sections, removal and plan sheets, and traffic maintenance plan(s).
4. Specifications and Special Provisions
5. Utility coordination including gathering information from utility companies and resolving conflicts as necessary.
6. Quantities and Cost Estimates
7. Project meetings with city staff, as necessary.

Bidding Phase

Support for city staff for one (1) local bid letting, including:

1. Distribution of plans to contractors and plan rooms.
2. Maintaining a bid register.
3. Attendance at a pre-bid meeting, if necessary.
4. Answering questions and providing clarifications and/or addenda, as necessary.
5. Attendance at the bid opening
6. Compiling a bid tabulation and recommendation for award of the contract.
7. Compiling and distribution of contracts for execution by the city and contractor.

Construction Phase

We anticipate that there will be one contract awarded to one contractor for the entire project. Our construction phase services will consist of the following items listed below:

1. Administering a Pre-Construction Meeting with the Contractor, City staff, and utility companies. Meeting minutes will be compiled and distributed to all attendees and other interested parties.
2. Full time construction observation will be provided during the critical phases of the project. Services will include inspecting and reviewing traffic control items, cold milling operations, HMA paving operations, density testing by use of a Troxler Nuclear Gauge, and reviewing drainage structure adjustments. Construction field services will be completed with one full time technician on site while work is progressing.
3. Completion of one asphalt extraction test to verify mix design conformance.
4. Completion of weekly progress meetings during construction to review schedule, upcoming work, and progress.

5. Construction administration including measuring and verifying quantities, creating contractor construction pay estimates and any necessary change orders.
6. Construction closeout including a final walk-through once the project is complete, development of a punchlist, and closeout paperwork necessary per City requirements.

Fees

Our fees to complete this project are proposed as follows:

<u>Phase</u>	<u>Fee</u>
Preliminary/Final Design	\$10,000
Bidding Phase	\$ 3,000
Construction Phase	<u>\$13,000</u>
TOTAL	<u>\$26,000</u>

Exclusions

The following items are excluded for this project:

1. Completion of Maintenance of Traffic plans and provisions beyond typical details and notes
2. Permanent sign replacement design or administration.
3. Changes in selected streets for paving, after submittal of draft plans.

Schedule

The following schedule is anticipated for this project:

Engineering Authorization	April, 2021
Design	April-May, 2021
Advertise for bidding	May, 2021
Construction Contract Award	June, 2021
Construction Start	July, 2021
Construction Complete	September, 2021

Thank you again for the opportunity to submit this proposal. If you have any questions, please feel free to contact me at (269) 926-4565 or Tony McGhee at (269) 252-8980 if you have any questions or need additional information.

Your signature on the provided Professional Services Agreement will serve as authorization to proceed as outlined above.

Sincerely,

ABONMARCHE

A handwritten signature in blue ink, appearing to read "J. Marquardt".

Jason Marquardt, PE
Senior Project Manager



TO: Mayor Humphrey and the New Buffalo City Council

FROM: Darwin Watson, City Manager

DATE: July 19, 2021

RE: Appointment of Act 51 Street Administrator

ITEM BEFORE THE COUNCIL:

Approval of the appointment of Darwin Watson as Street Administrator for the City of New Buffalo

Discussion:

Michigan Public Act 51 of 1951 created the Michigan Transportation Fund (MTF), and it is the main road funding source for most cities and villages. This Act defines the formula by which Michigan distributes money for road maintenance to cities, villages, and counties. Section 13(9) requires that municipalities designate a Street Administrator.

Currently, former City Manager David Richards is designated as the Street Administrator for the City of New Buffalo.

RECOMMENDATION:

That the Mayor Humphrey and the New Buffalo City Council designate Darwin Watson as Street Administrator for the City of New Buffalo.

RESOLUTION FOR DESIGNATION OF STREET ADMINISTRATOR

This information is required by Act 51, P.A. 1951 as amended. Failure to supply this information will result in funds being withheld.

MAIL TO: Michigan Department of Transportation, Financial Operations
Division, P.O. Box 30050, Lansing, MI 48909.
or Fax to: (517) 335-1828

NOTE: Indicate, if possible, where Street Administrator can usually be reached during normal working hours, if different than City or Village Office. List any other office held by the Administrator.

Councilperson or Commissioner _____

offered the following resolution and moved its adoption:

Whereas, Section 13(9) of Act 51, Public Acts of 1951 provided that each incorporated city and village to which funds are returned under the provisions of this section, that, "the responsibility for street improvements, maintenance, and traffic operations work, and the development, construction, or repair of off-street parking facilities and construction or repair of street lighting shall be coordinated by a single administrator to be designated by the governing body who shall be responsible for and shall represent the municipality in transactions with the State Transportation Department pursuant to this act."

Therefore, be it resolved, that this Honorable Body designate _____

_____ as the single Street Administrator for the City or Village of

_____ in all transactions with the State Transportation Department

as provided in Section 13 of the Act.

Supported by the Councilperson or Commissioner _____

Yeas _____

Nays _____

I hereby certify that the foregoing is a true and correct copy of a resolution made and adopted at a regular meeting of the governing body of this municipality on the _____ day of

CITY OR VILLAGE CLERK (SIGNATURE)	E-MAIL ADDRESS	DATE
STREET ADMINISTRATOR (SIGNATURE)	E-MAIL ADDRESS	DATE
ADDRESS OF CITY OR VILLAGE OFFICE		P.O. BOX
CITY OR VILLAGE	ZIP CODE	PHONE NUMBER



TO: Mayor Humphrey and the New Buffalo City Council

FROM: Darwin Watson, City Manager

DATE: July 19, 2021

RE: Second Reading of Ordinance Amendment to Chapter 9

ITEM BEFORE THE COUNCIL:

Approve the second reading of amendment to Chapter 9 of the City of New Buffalo Code of Ordinances – General Business Registration

DISCUSSION:

In most cities, basic business registrations usually enable a company and its owner to start collecting receipts for work conducted within city limits. There are some instances that certain businesses may require additional city approval. In some cities becoming registered may qualify businesses to bid on government contracts.

More importantly, business registrations allow for the city to ensure the overall welfare of the community. The annual renewal of the business registrations allows for confirmation of the proper safety protocols, American with Disabilities (ADA) compliance, and operational functionality (HVAC, electrical, etc.).

RECOMMENDATION:

That Mayor Humphrey and the New Buffalo City Council approve the second reading of the ordinance to amend Chapter 9 of the New Buffalo Code of Ordinances to establish General Business Registrations

**CITY OF NEW BUFFALO
BERRIEN COUNTY, MICHIGAN**

ORDINANCE NO. ____

**ORDINANCE TO AMEND CHAPTER 9; ARTICLE II; SECTIONS 9-5 THROUGH 9-16 OF THE NEW
BUFFALO CITY CODE OF ORDINANCES FOR GENERAL BUSINESS REGISTRATION ORDINANCE**

THE CITY OF NEW BUFFALO ORDAINS:

Section 1. Amendment. Sections 9-5 through 9-15 of the New Buffalo City Code is amended to read in its entirety as follows:

Section 9-5 Short title.

This article shall be known and may be cited as the “General Business Registration Ordinance.”

Section 9-6 Definitions.

For the purposes of this article, the following terms, phrases, words, and their derivations shall have the meanings given herein. When not inconsistent with the context, words used in the present tense include the future, words in the plural number include the singular number, and words in the singular number include the plural number. The word “shall” is always mandatory and not merely directory.

Business

All kinds of vocations, occupations, professions, enterprises, establishments and all other kinds of activities and matters, together with all devices, machines, vehicles and appurtenances used therein, any of which are conducted for private profit, or benefit, either directly or indirectly, on any premises in this city or anywhere else within its jurisdiction.

City

The City of New Buffalo, Michigan and its departments, officers or individuals designated by the City Manager or City Council to administer all or any part of the permitting and inspection programs under this chapter.

City Council

The City Council of the City of New Buffalo, Michigan.

City Manager

The City Manager of the City of New Buffalo, Michigan.

Insignia (or its singular number insigne)

Any tag, plate, badge, emblem, sticker, or any other kind of device which may be required for any use in connection with any license.

Registration or registrant licensee

As used generally herein shall include respectively the words “permit” or “permittee,” or the holder for any use or period of any similar privilege, wherever relevant to any provision of this article or other law or ordinance.

Person

Include individual natural persons, partnerships, joint adventures, societies, associations, clubs, trustees, trusts, or corporations; or any officers, agents, employees, factors, or any kind of personal

representatives of any thereof, in any capacity, acting either for himself or for any other person, under either personal appointment or pursuant to law.

Premises

Includes all land structures, places, and the equipment and appurtenances connected or used in any business, and any personal property which is either affixed to or is otherwise use in connection with any such business conducted on such premises.

Public Safety and Code Enforcement

Includes the Police Department, Fire Department, Building Department and Code Enforcement Department of the City of New Buffalo, Michigan.

Section 9-7 Application of regulations.

- A. *Compliance required.* It shall be unlawful for any person, either directly or indirectly to conduct any business or nonprofit enterprise or to use in connection therewith any vehicle, premises, machine, or device, in whole or in part, for which registration or a permit is required by any law or ordinance of this city, without registration of that business with the city as required by this article or other law or ordinance of the city. This article applies to all businesses and nonprofit enterprises which occupy any premises located in the city which is owned by, leased by, licensed for the use of or otherwise the responsibility of or under the direction of that business or nonprofit enterprise. It shall also apply to any business and nonprofit enterprises which, repeatedly though intermittently occupy any premises in the city. It shall also apply to transient sellers of goods or nonprofessional services.
- B. *Exceptions.* This article does not apply to individuals with permanent business or nonprofit enterprise establishment outside the city who meet in the city with previously arranged appointments in a restaurant, motel or hotel or the premises of a registered business or nonprofit enterprise located in the city. It also shall not apply to any person if its application to such person would render this article or any portion of it unconstitutional or unlawful.
- C. *Single act.* Except as otherwise provided in this section, for the purpose of this article, any person shall be deemed to be in business or engaging in a nonprofit enterprise and thus subject to the requirements of this article when that person does one act of:
 - (1) Selling any goods or services;
 - (2) Soliciting business or offering goods or services for sale or hire;
 - (3) Using any vehicle or any premises in the city for business purposes;
 - (4) Provides any services for any type of remuneration or consideration.
- D. *Agents responsible for registering.* The agents or other representatives of nonresidents who are doing business in this city shall be personally responsible for the compliance of their principals and of the business they represent with the provisions of this article.
- E. *Joint registration.* A person engaged in two (2) or more businesses at the same location shall not be required to obtain separate registrations for conducting each business but, when eligible, shall be issued one registration which shall specify on its face all such businesses.
- F. *No license required for mere delivery. [Nonprofit, charitable, and religious purposes]* The City Manager shall issue special permits, without the payment of any license fee or other charges, to any person or organization for the conduct or operation of a nonprofit enterprise, either regularly or temporarily when he finds that the applicant operates without private profit for a public, charitable, educational, literary, fraternal or religious purpose.

Section 9-8 Duties of city.

- (a) The city shall collect all registration fees and shall register the name of all persons qualified under the provisions of this article and shall:
 - (1) Promulgate and enforce all reasonable rules and regulations necessary to the operation and enforcement of this article;
 - (2) Submit all applications to interested city officials for their endorsements thereon as to compliance by the applicant with all city regulations which they have the duty of enforcing;
 - (3) Investigate and determine the eligibility of any applicant for registration as prescribed herein;
 - (4) Notify any applicant of the acceptance or rejection of an application and shall, upon refusal of any registration or permit, at the applicant's request, state in writing the reasons and deliver them to the applicant by first class mail to an address provided by the applicant.

Section 9-9 Issuance of license.

- (a) *Application required.* Every person required to register under the provisions of this article shall apply for such registration to the city. The application shall:
 - (1) Be in writing upon forms provided by the city;
 - (2) Require the disclosure of all information which the city shall find to be reasonably necessary to the fair administration of this article;
 - (3) Be accompanied by the full amount of the fees chargeable for such registration.
- (b) *Issuance of receipts.* Whenever a registration cannot be issued at the time the application for the same is made, the city shall issue a receipt to the applicant for the money paid in advance. Such receipt shall not be construed as the approval of the city for registration; nor shall it entitle or authorize the applicant to open or maintain any business contrary to the provisions of this article.
- (c) *Annual renewal procedures.* The applicant for the renewal of a registration previously approved shall apply for such registration to the city annually. The application shall disclose the conduct and operation of the applicant's business during the preceding registration period as it is reasonably necessary to the determination by the city of the applicant's eligibility for continued registration.
 - (1) The term of the business registration issued under this Article is twelve months (January 1- December 31).
 - (2) Applicants for renewal of business registration shall apply to the city 45 days prior to the date of expiration of the license.
 - (3) An application for renewal of a license shall be considered in the same manner as the original application.
- (d) *Duplicate registration.* A duplicate registration certificate shall be issued for one which has been lost, stolen, defaced or destroyed. There shall be no additional fee charged for duplicate issuance.
- (e) *Denial of registration.* The city shall disapprove any application where the applicant's business premises fail to comply with any applicable law, rule, regulation, ordinance provision or lawful order or directive. Upon disapproving any application submitted under the provisions of this article, the city shall refund all fees paid in advance by the applicant provided the applicant is not otherwise indebted to the city.
- (f) *Compliance pending legal action.* When registration is denied and any action is instituted by the applicant to appeal its denial or to compel its issuance, such applicant shall not engage in a business for which the registration was refused unless a registration certificate be issued pursuant to a judgment ordering the same.

Section 9-10 Fee rate.

- (a) The annual general business registration fee shall be in the amount of thirty-five dollars (\$35.00).
- (b) Fees shall be reviewed annually and adjusted, as deemed necessary, by the City Council.
- (c) Fees shall be prorated for partial years.
- (d) Except as provided in this ordinance, no rebate or refund of any fee or part shall be made by reason of the nonuse of such registration or by reason of a change of location or business rendering the use of such registration ineffective.

Section 9-11 Registration certificate.

Each registration issued hereunder shall state upon its face the name of the registrant and any other name under which such business is to be conducted, business address, the dates of issuance and expiration.

Section 9-12 Duties of registrant licensee.

- (a) *General standards of conduct.* Every registrant under this article shall:
 - (1) Ascertain and always comply with all laws, ordinances and regulations applicable to such business;
 - (2) Avoid all forbidden, improper or unnecessary practices or conditions which do or may affect the public health, safety and general welfare.
- (b) *Display of registration.* Every registrant shall display the registration certificate at the business premises. If the registrant does not have an actual physical business premises or utilize such premises on an intermittent basis, the registrant shall carry such registration on their person.
- (c) *Inoperative registration.* No registrant shall allow any registration to remain posted or displayed or used after the period for which it was issued has expired, or when it has been suspended or revoked or for any other reason become ineffective.
- (d) *Unlawful possession.* No registrant shall loan, sell, give or assign to any person, or allow any other person to use or display, or destroy, damage or remove, or to have in his possession, except as authorized by the city or by law, any registration which has been issued to said registrant.
- (e) *New location desired.* A registrant shall have the right to change the location of the registered business; provided the registrant shall obtain written permission from the city for such change of location and promptly report the completed act of such transfer to the city and surrender the original registration certificate.
- (f) *New registration issued.* Upon the completion of a transfer of registration in compliance with subsection (e) above, the city shall issue a new registration certificate to the transferee for the unexpired term of the old registration.

Section 9-13 Enforcement

- (a) *Inspection of premises.*
 - (1) *Persons authorized.* The following city official(s) are authorized to conduct inspections in the manner prescribed herein:
 - a. Public Safety and Code Enforcement shall make all investigations reasonably necessary to the enforcement of this article;
 - b. Public safety and Code Enforcement shall have the authority to inspect and examine businesses within the City of New Buffalo to enforce compliance with this article.

- (2) *Authority to inspect.* All persons authorized to inspect businesses shall have the authority to enter pursuant to law, with or without search warrant, at all reasonable times, the following premises:
 - a. Those for which registration is required;
 - b. Those for which registration certificates were issued and which, at the time of inspection, are operating under such registration;
 - c. Those for which the registration has been revoked or suspended.
- (3) *Inspection Reports.* Persons inspecting registrants, their businesses or premises as authorized shall report all violations of this article or of other laws or ordinances through the chain of command to the city manager and shall submit such other reports as the city manager shall order.

- (b) *Provisional order.* When an official authorized with the enforcement of this article determines that a violation of this article has occurred, the city shall issue to the affected person a provisional order to comply. The provisional order shall be in writing and shall be personally served and shall apprise the person affected of the specific violation(s). In the absence of the person affected or his agent or employee, a copy of such notice shall be affixed to some structure or posted in a conspicuous location on the premises. Depositing such notice in the United States mail shall also constitute service. The provisional order shall require compliance within ten (10) business days of service on the affected person.
- (c) *Citation.* Upon the failure or refusal of the violator to comply with the provisional order, the enforcement official shall issue a citation for the violation.

Section 9-14 Penalty.

Any person and/or business convicted of violating any provision of this general business registration article shall be guilty of a misdemeanor and subject to the penalties of Chapter 1, Section 1-7 of the Code of Ordinances of the City of New Buffalo, Michigan, except that there shall be a minimum fine of one hundred dollars (\$100.00) for each violation.

Section 9-15 Liability of violator.

The amount of any unpaid fee, the payment of which is required as provided for under the terms of this article, shall constitute a debt to the city which may be collected by an action at law or may be certified on the delinquent tax rolls of the city as prescribed by law.

Section 2. Publication and Effective Date. The City Clerk shall cause this ordinance or a summary thereof to be published in a newspaper of general circulation in the City, and the ordinance shall be effective 20 days after enactment or upon publication, whichever is later.

YEAS: _____
 NAYS: _____
 ABSTAIN: _____
 ABSENT: _____

CERTIFICATION

This is a true and complete copy of Ordinance No. ____ adopted at a regular meeting of the New Buffalo City Council held on _____, 2021.

John Humphrey, Mayor

Ann M. Fidler, Clerk

DRAFT



TO: Mayor Humphrey and the New Buffalo City Council

FROM: Darwin Watson, City Manager

DATE: July 19, 2021

RE: Second Reading of Ordinance Amendment to Chapter 15; Article II

ITEM BEFORE THE COUNCIL:

Approval of second reading of amendment to Chapter 15; Article II of the City of New Buffalo Code of Ordinances to Regulate the Preparation and Collection of Solid Waste

DISCUSSION:

This ordinance addresses the manner in which solid waste is disposed of, times, and placement of solid waste containers for collection. It also identifies the procedures for remedying violations that occur if items are left in the right-of-way.

In August 2020, amendments were made to the ordinance and recently, there have been some challenges with enforcement. After being advised of the challenges that exist, additional amendments were necessary.

The first reading of this proposed ordinance amendment occurred at the June 22, 2021, City Council meeting. Following the initial reading, and a review, there were some modifications to the proposed amendment. The modifications were as follows:

- A definition of Construction & Demolition Waste material was added;
- The times for set out and removal times were adjusted to 3:00 PM and 8:00 PM, respectively;
- Refuse was replaced by rubbish; and
- The notification of violation, identified in 15-9 C. (1), shall be given to the owner **and** occupant (where applicable).

RECOMMENDATION:

That Mayor Humphrey and the New Buffalo City Council approve the second reading of the ordinance to amend Chapter 15; Article II of the New Buffalo Code of Ordinances to regulate the preparation and collection of solid waste

**CITY OF NEW BUFFALO
BERRIEN COUNTY, MICHIGAN**

ORDINANCE NO. ____

**ORDINANCE TO AMEND CHAPTER 15; SECTIONS 15-2, 15-7 AND 15-9 OF THE NEW
BUFFALO CITY CODE OF ORDINANCES TO REGULATE THE PREPARATION AND
COLLECTION OF SOLID WASTE**

The City of New Buffalo ordains:

Section 1. Addition of Definition. Article II, Section 15-2 of the New Buffalo City Code is amended to add the definition of “Construction & Demolition Waste Material”, which shall appear between the definition of “Ashes” and “Garbage” to read as follows:

CONSTRUCTION & DEMOLITION WASTE MATERIAL

Construction and demolition waste material shall mean those materials resulting from the alteration, construction, destruction, rehabilitation, or repair of any manmade physical structure including houses, buildings, industrial or commercial facilities, and roadways. This shall include:

- brick, concrete and other masonry materials
- stone
- glass
- wall coverings
- drywall
- framing and finishing lumber
- roofing materials
- plumbing fixtures (e.g., toilets, sinks, water heaters, pipes)
- heating equipment (e.g., furnaces, duct work)
- electrical wiring and components containing no hazardous fluids or refrigerants
- insulation
- carpeting
- asphaltic substances
- metal (incidental to any of the above)
- weathered railroad ties and weathered utility poles

Construction and demolition waste material does not include:

- materials whose removal has been required prior to demolition (e.g., National Emission Standards for Hazardous Air Pollutants (NESHAP) regulated asbestos and Toxic Substances Control Act (TSCA) regulated PCB containing materials)
- materials identified or listed as solid wastes, infectious wastes, or hazardous waste(s)
- materials resulting from mining operations, nontoxic fly ash, spent nontoxic foundry sand, or slag
- containerized or bulk liquids, fuel tanks, drums and other closed or filled containers, tires, and equipment or vehicular batteries

Section 2. Amendment of Definitions. Article II Section 15-2 of the New Buffalo City Code is amended to modify the definition of “Rubbish” to read as follows:

RUBBISH

Garbage and nonputrescible solid wastes (excluding ashes), consisting of both combustible and noncombustible wastes, such as paper, cardboard, metal cans, wood, glass, bedding, crockery, and similar materials; **but not to include body waste, automobile frames or debris resulting from construction, reconstruction, or repair of premises.**

Section 2. Amendment. Sections 15-7 and 15-9 of the New Buffalo City Code are amended to read in its entirety as follows:

Sec. 15-7 Responsibilities of property owner and occupants

- A. All property owners and occupants who receive refuse collection services contracted by the City pursuant to Section 15.3 shall comply with the terms and conditions of the applicable contract, which shall be available for public inspection in the office of the City Clerk. Such contracts may address topics, including:
 1. Size and other specifications for refuse bins;
 2. Appropriate locations for placing refuse bins prior to pick up;
 3. Size limitations for the curbside pickup of bulk items and yard waste; and
 4. Appropriate separation of refuse and recyclable materials.
- B. Refuse and recycling receptacles shall not be set out for collection prior to ~~8:00 a.m.~~ **3:00 PM** preceding the day of collection. After such receptacles are emptied, they shall, on the same day collections are made, be removed from the street right-of-way and stored in an appropriate location in the side or rear yard of the property no later than ~~8:00 p.m.~~ **8:00 PM**. Receptacles shall not be stored in the front yard.
- C. Downed trees and tree limbs exceeding two cubic yards in volume or four feet in length do not constitute "yard waste" for purposes of this chapter and therefore are not eligible for regular curbside pickup by the City or its contractors. Property owners and occupants shall be responsible for disposing of such items.
- D. Grass, brush, leaves, and limbs up to four inches in diameter are considered yard waste, but brush and limbs must be cut to a length of four feet or less. These items must be placed in a thirty-two (32) gallon container, or biodegradable paper bag of not more than **thirty-two** (32) gallons and tied in a bundle not to exceed 50 pounds.
- E. ***The owner or occupant of any lands and premises within the city upon which any building or structure is being constructed, remodeled, altered or repaired shall cause all construction and demolition waste material resulting from such work to be removed and disposed of, and no such construction and demolition waste material shall be deposited or placed on any street, public right-of-way, alley or other public place within the city.***

Sec. 15-9 Authority to remove unauthorized items from right-of-way and recover costs.

In addition to any other available remedy, the City may remove unauthorized items from the street right-of-way and recover costs from the property owner in accordance with the following procedures:

- A. For purposes of this section, unauthorized items in the right-of-way include:
 1. ~~Refuse~~ **Rubbish** receptacles placed at the street in violation of Section **15-7B** above;
 2. Trees or tree limbs too large for curbside pickup; and
 3. Other items not suitable for curbside pickup.

- B. Upon observing an unauthorized item in the right-of-way, the City Manager or designee is authorized to notify, in writing, the owner of the adjoining premises that the City intends to remove such item at the owner's expense. Such notice shall be served by hand delivery or posted in a conspicuous location on the premises.
- C. After service of the notice, the owner shall remove the unauthorized item from the right-of-way within **twenty-four** (24) hours. If he or she fails to do so, the city may remove the item violation at the owner's expense. ~~as follows:~~
1. If the item is a ~~refuse~~ **rubbish** or recycling receptacle, the City shall ~~contract to collect and store the receptacle and release it back to the owner or occupant upon payment of a fee in the amount of \$75.~~ remediate and **serve notice to the owner and occupants (when applicable) of the premises upon which, or adjacent to which, a violation of this section occurred.**
 - a. **The first violation in a calendar year the property owner or occupant shall receive a written warning (via first class mail or hand delivery), as well as a copy of the ordinance from which this section derived; and**
 - b. **Any subsequent violations shall be served by hand delivery to or posted in a conspicuous location on the premises and result in a fifty-dollar (\$50.00) fine.**

Such charges shall be billed, collected, and, in all cases, there shall be an additional late charge (consistent with the penalty assessed in Section 19-13 Bills and billing; penalty for late payment) if the fee is not paid within thirty (30) days of the notice date, or in the event an appeal is filed and denied, within thirty (30) days of the mailing of the denial notice.

Notice of the existence of and reason for such a lien shall be mailed to the property owner's last known address. If payment is not received, the city may levy a single-lot special assessment to recover such costs pursuant to Chapter 17, Article V, of the City Code.
 2. If the item is not a ~~refuse~~ **rubbish** or recycling receptacle, the City may dispose of the item or contract to do so and send the owner an invoice for the actual cost of removal and disposal plus a \$50 administration fee. Such invoice shall be paid within 30 days. If payment is not received, the city may levy a single-lot special assessment to recover such costs pursuant to Chapter 17, Article V, of the City Code.
 3. If the item is a ~~refuse~~ **rubbish** or recycling receptacle containing waste, the City shall ~~contract to collect the receptacle, store it and release it back to the owner or occupant upon payment of a fee in the amount of \$100.~~ **take the necessary measures to dispose of the waste or contract to do so and send the owner an invoice for the actual cost of the disposal and an additional \$50.00 administration fee. Such invoice shall be paid within 30 days.**
 4. **If payment is not received in any of the cases identified in 1-3 above, the city may levy a single-lot special assessment to recover such costs pursuant to Chapter 17, Article V, of the City Code.**
- D. This section shall not be construed to limit the authority of the City to relocate or remove unauthorized items from the right-of-way at the City's own cost without prior notice to the adjoining owner.

Section 3. Publication and Effective Date. The City Clerk shall cause this ordinance or a summary thereof to be published in a newspaper of general circulation in the City, and the ordinance shall be effective 20 days after enactment or upon publication, whichever is later.

YEAS: _____

NAYS: _____

ABSTAIN: _____

ABSENT: _____

CERTIFICATION

This is a true and complete copy of Ordinance No. ____ adopted at a regular meeting of the New Buffalo City Council held on _____, 2021.

John Humphrey, Mayor

Ann M. Fidler, Clerk

DRAFT