

CITY OF OAKWOOD  
COUNCIL AGENDA  
MARCH 7, 2022

7:30 P.M.

- I. CALL TO ORDER
- II. PLEDGE OF ALLEGIANCE
- III. ROLL CALL
- IV. MINUTES OF FEBRUARY 7 REGULAR SESSION & WORK SESSION AND  
FEBRUARY 28 WORK SESSION & EXECUTIVE SESSION
- V. STATUS REPORTS
  - Citizen Committee Appointments
- VI. VISITORS
- VII. LEGISLATION
  - An Ordinance to adopt an updated Property Maintenance Code, Vice Mayor Byington
  - An Ordinance to adjust the boundary lines between the city of Oakwood and the city of Kettering, Vice Mayor Byington
  - A Resolution of Necessity for 2023 Street Lighting, Mr. Stephens
  - An Ordinance to Proceed with the 2023 Street Lighting Program, Mr. Stephens
  - A Resolution to continue emergency management services in conjunction with the Montgomery County Office of Emergency Management, Mayor Duncan
- VIII. STAFF REPORT – PERSONNEL & PROPERTIES DEPARTMENT
- IX. AN OAKWOOD MOMENT
- X. CITY MANAGER’S REPORT
- XI. COUNCIL COMMENTS
- XII. ADJOURN

NEXT REGULAR SESSION SCHEDULED FOR APRIL 4, 2022

AN ORDINANCE

BY: \_\_\_\_\_

NO. \_\_\_\_\_

TO REPEAL THE OAKWOOD PROPERTY MAINTENANCE CODE IN ITS ENTIRETY, WHICH WAS BASED UPON THE 2003 INTERNATIONAL PROPERTY MAINTENANCE CODE, AND TO ADOPT A NEW OAKWOOD PROPERTY MAINTENANCE CODE BASED UPON THE 2021 INTERNATIONAL PROPERTY MAINTENANCE CODE.

BE IT ORDAINED BY THE COUNCIL OF THE CITY OF OAKWOOD, STATE OF OHIO, THAT:

SECTION I.

Existing Title 17, the Oakwood Property Maintenance Code based upon the 2003 version of the International Property Maintenance Code, is hereby repealed.

SECTION II.

The attached Exhibit, which is incorporated herein by this reference, is hereby adopted as new Title 17 of the Codified Ordinances of the city of Oakwood. Title 17 may also be referred to as the Oakwood Property Maintenance Code, and is based upon the 2021 version of the International Property Maintenance Code.

SECTION III.

It is hereby found and determined that all formal actions of this Council concerning and relating to the passage of this ordinance were adopted in an open meeting of this Council and that all deliberations of this Council and of any of its committees that resulted in such formal action were in compliance with all legal requirements including § 121.22, Ohio Revised Code.

SECTION IV.

This ordinance shall take effect as of the earliest date permitted by law.

PASSED BY COUNCIL OF THE CITY OF OAKWOOD, this \_\_\_\_ day of \_\_\_\_\_, 2022.

\_\_\_\_\_  
Mayor William D. Duncan

ATTEST:

\_\_\_\_\_  
Clerk of Council

TO THE CLERK:

Please publish the foregoing by incorporating the same into the Codified Ordinances of the city.

\_\_\_\_\_  
City Attorney Robert F. Jacques

The Oakwood Property Maintenance Code is based on the

2021 International Property Maintenance Code<sup>®</sup>

Date of First Publication: September 30, 2020

First Printing: September 2020.

ISBN: 978-1-60983-971-0 (soft-cover edition)

COPYRIGHT □ 2020

By

INTERNATIONAL CODE COUNCIL, INC.

ALL RIGHTS RESERVED. EXCEPT AS TO MODIFICATIONS HEREIN BY THE CITY OF OAKWOOD, the 2021 *International Property Maintenance Code* □ is a copyrighted work owned by the International Code Council, Inc. Without advance written permission from the copyright owner, no part of this book may be reproduced, distributed or transmitted in any form or by any means, including, without limitation, electronic, optical or mechanical means (by way of example, and not limitation, photocopying or recording by or in an information storage retrieval system). For information on use rights and permissions, please contact: Publications, 4051 Flossmoor Road, Country Club Hills, IL 60478. Phone 1-888-ICC-SAFE (422-7233).

Trademarks: “International Code Council,” the “International Code Council” logo, “ICC,” the “ICC” logo, “International Property Maintenance Code,” “IPMC” and other names and trademarks appearing in this book are trademarks of the International Code Council, Inc., and/or its licensors (as applicable), and may not be used without permission.

PRINTED IN THE USA

**CHAPTER 1**  
**SCOPE AND ADMINISTRATION**

**PART 1 — SCOPE AND APPLICATION**

**SECTION 101**  
**SCOPE AND GENERAL REQUIREMENTS**

**101.1 Title.**

These regulations shall be known as the *Oakwood Property Maintenance Code*, hereinafter referred to as “this code.”

**[A] 101.2 Scope.**

The provisions of this code shall apply to all existing residential and nonresidential structures and all existing *premises* and constitute minimum requirements and standards for *premises*, structures, equipment and facilities for light, *ventilation*, space, heating, sanitation, protection from the elements, a reasonable level of safety from fire and other hazards, and for a reasonable level of sanitary maintenance; the responsibility of *owners*, an *owner’s* authorized agent, *operators* and *occupants*; the *occupancy* of existing structures and *premises*, and for administration, enforcement and penalties.

**[A] 101.3 Purpose.**

The purpose of this code is to establish minimum requirements to provide a reasonable level of health, safety, property protection and general welfare insofar as they are affected by the continued *occupancy* and maintenance of structures and *premises*. Existing structures and *premises* that do not comply with these provisions shall be altered or repaired to provide a reasonable minimum level of health, safety and general welfare as required herein. Additional purposes of this code include, but are not limited to, the conservation and protection of property values throughout the city of Oakwood, the protection and improvement of aesthetic aspects of premises and of the city of Oakwood as a whole, and the protection against and elimination of nuisances.

**[A] 101.4 Severability.**

If a section, subsection, sentence, clause or phrase of this code is, for any reason, held to be unconstitutional or otherwise invalid, such decision shall not affect the validity of the remaining portions of this code.

**SECTION 102**  
**APPLICABILITY**

**[A] 102.1 General.**

Where there is a conflict between a general requirement and a specific requirement, the specific requirement shall govern. Where differences occur between provisions of this code and the referenced standards, the provisions of this code shall apply. Where, in a specific case, different sections of this code specify different requirements, the most restrictive shall govern.

**102.2 Maintenance.**

Equipment, systems, devices and safeguards required by this code or a previous regulation or code under which the *structure* or *premises* was constructed, altered or repaired shall be maintained in good working

order. An *owner*, *owner's* authorized agent, *operator* or *occupant* shall not cause any service, facility, equipment or utility that is required under this section to be removed from, shut off from or discontinued for any occupied dwelling, except for such temporary interruption as necessary while repairs or alterations are in progress. The requirements of this code are not intended to provide the basis for removal or abrogation of fire protection and safety systems and devices in existing structures. Except as otherwise specified herein, the *owner* or the *owner's* authorized agent shall be responsible for the maintenance of buildings, structures and *premises*.

**[A] 102.3 Application of other codes.**

Repairs, additions or alterations to a *structure*, or changes of *occupancy*, shall be done in accordance with the procedures and provisions of all applicable state and/or local codes. Nothing in this code shall be construed to cancel, modify or set aside any provision of the Oakwood Zoning Code.

**[A] 102.4 Existing remedies.**

The provisions in this code shall not be construed to abolish or impair existing remedies of the jurisdiction or its officers or agencies relating to the removal or demolition of any *structure* that is dangerous, unsafe and insanitary.

**[A] 102.5 Workmanship.**

Repairs, maintenance work, alterations or installations that are caused directly or indirectly by the enforcement of this code shall be executed and installed in a *workmanlike* manner and installed in accordance with the manufacturer's instructions.

**102.6 Structural analysis.**

Where structural analysis is used to determine if an unsafe structural condition exists, the analysis shall be permitted to use nominal strengths, nominal loads, load effects, required strengths and limit states in accordance with the requirements under which the *structure* was constructed or in accordance with any subsequent requirement.

**[A] 102.7 Historic buildings.**

The provisions of this code shall not be mandatory for existing buildings or structures duly designated as historic buildings, such as, by way of example and not of limitation, inclusion of such building or structure on the National Register of Historic Places, where such buildings or structures are judged by the *code official* to be safe and in the public interest of health, safety and welfare.

**[A] 102.8 Referenced codes and standards.**

The codes and standards referenced in this code shall be those that are listed in Chapter 8 and considered part of the requirements of this code to the prescribed extent of each such reference and as further regulated in Sections 102.8.1 and 102.8.2.

**Exception:** Where enforcement of a code provision would violate the conditions of the listing of the equipment or appliance, the conditions of the listing shall apply.

**[A] 102.8.1 Conflicts.**

Where conflicts occur between provisions of this code and the referenced standards, the provisions of this code shall apply.

**[A] 102.8.2 Provisions in referenced codes and standards.**

Where the extent of the reference to a referenced code or standard includes subject matter that is within the scope of this code, the provisions of this code, as applicable, shall take precedence over the provisions in the referenced code or standard.

**[A] 102.9 Requirements not covered by code.**

Requirements necessary for the strength, stability or proper operation of an existing fixture, *structure* or equipment, or for the public safety, health and general welfare, not specifically covered by this code, shall be determined by the *code official*.

**[A] 102.10 Application of references.**

References to chapter or section numbers, or to provisions not specifically identified by number, shall be construed to refer to such chapter, section or provision of this code.

**[A] 102.11 Other laws.**

The provisions of this code shall not be deemed to nullify any provisions of local, state or federal law.

**PART 2 — ADMINISTRATION AND ENFORCEMENT**

**SECTION 103  
CODE COMPLIANCE ADMINISTRATION**

**[A] 103.1 General Administration.**

Compliance with this code shall be overseen by the Building Commissioner, who shall be assisted in its implementation, administration and enforcement by the Code Enforcement Officer. They may be assisted as needed by other city staff, including but not limited to the City Attorney. For purposes of this code, the term “*code official*” shall refer to the Building Commissioner and, as appropriate, to the Code Enforcement Officer acting under his or her direction.

**[A] 103.2 Appointment.**

The *code official* shall be appointed by the City Manager.

**SECTION 104  
FEES**

**[A] 104.1 Fees.**

The fees for activities and services performed by the city in carrying out its responsibilities under this code shall be as set forth in the general fee schedule for this city, as adopted under Section 153 of the Oakwood Administrative Code and amended from time to time.

**SECTION 105  
DUTIES AND POWERS OF THE CODE OFFICIAL**

**[A] 105.1 General.**

The *code official* is hereby authorized and directed to enforce the provisions of this code. The *code official* shall have the authority to render interpretations of this code and to adopt policies and procedures in order to clarify the application of its provisions. Such interpretations, policies and procedures shall be in compliance with the intent and purpose of this code. Such policies and procedures shall not have the effect of waiving requirements specifically provided for in this code.

**[A] 105.2 Inspections.**

The *code official* shall make all of the required inspections, or shall accept reports of inspection by *approved* agencies or individuals. Reports of such inspections shall be in writing and be certified by a responsible officer of such *approved* agency or by the responsible individual. The *code official* is authorized to engage such expert opinion as deemed necessary to report on unusual technical issues that arise, subject to the approval of the City Manager.

**[A] 105.3 Right of entry.**

Where it is necessary to make an inspection to enforce the provisions of this code, or whenever the *code official* has reasonable cause to believe that there exists in a *structure* or upon a *premises* a condition in violation of this code, the *code official* is authorized to enter the *structure* or *premises* at reasonable times to inspect or perform the duties imposed by this code, provided that if such *structure* or *premises* is occupied the *code official* shall present credentials to the occupant and request entry. If such *structure* or *premises* is unoccupied, the *code official* shall first make a reasonable effort to locate the *owner*, *owner's* authorized agent or other person having charge or control of the *structure* or *premises* and request entry. If entry is refused, the *code official* shall have recourse to the remedies provided by law to secure entry.

Furthermore:

- A. To the extent the owner or occupant has agreed to allow the *code official* access to the structure or premises, the *code official* shall be deemed to be an agent of the owner or occupant.
- B. In addition to any other remedy provided by law, if the owner, occupant, or agent thereof does not consent to the proposed inspection, the *code official* may appear before any judge in a court of competent jurisdiction and seek an administrative search warrant to allow an inspection. Any such application shall be made within ten (10) calendar days after the nonconsent. The application for the warrant shall specify the basis upon which the warrant is being sought and shall include a statement that the inspection will be limited to a determination whether there are violations of the code provisions identified in this section, or any other zoning, housing, or building code under the jurisdiction of the *code official*.

The court may consider any of the following factors along with such other matters as it deems pertinent in its decision as to whether a warrant shall be issued:

- 1. Eyewitness account of violation;
- 2. Citizen complaints;
- 3. Tenant complaints;
- 4. Plain view violations;
- 5. Violations apparent from city records;
- 6. Property deterioration;
- 7. Age of property;
- 8. Nature of alleged violation;
- 9. Condition of similar properties in the area;
- 10. Documented violations on similar properties in the area;
- 11. Passage of time since last inspection;
- 12. Previous violations on the property.

If a warrant is issued, no owner, occupant, or agent thereof shall fail or neglect, upon presentation of a warrant, to properly permit entry therein by the *code official* or his/her duly authorized designee for the purpose of inspection and examination pursuant to this section and consistent with the terms of the warrant. If the court declines to issue a warrant, or if no warrant is sought,

the inspection may still take place but the scope thereof shall be limited to such areas as are in plain view. No criminal penalty shall attach, nor shall any certificate of occupancy be denied, solely by reason of the owner's, occupant's, or agent's refusal to consent to an inspection.

**[A] 105.4 Identification.**

The *code official* shall carry proper identification when inspecting *structures* or *premises* in the performance of duties under this code.

**[A] 105.5 Notices and orders.**

The *code official* shall issue all necessary notices or orders to ensure compliance with this code.

**[A] 105.6 Department records.**

The *code official* shall keep official records of all business and activities of the department specified in the provisions of this code. Such records shall be retained in the official records for the period required for retention of public records.

**[A] 105.7 Liability.**

The *code official*, member of the board of appeals or employee charged with the enforcement of this code, while acting for the jurisdiction, in good faith and without malice in the discharge of the duties required by this code or other pertinent law or ordinance, shall not thereby be rendered civilly or criminally liable personally, and is hereby relieved from all personal liability for any damage accruing to persons or property as a result of an act or by reason of an act or omission in the discharge of official duties.

**[A] 105.7.1 Legal defense.**

Any suit or criminal complaint instituted against any officer or employee because of an act performed by that officer or employee in the lawful discharge of duties and under the provisions of this code shall be defended by the legal representative of the jurisdiction until the final termination of the proceedings. The *code official* or any subordinate shall not be liable for costs in an action, suit or proceeding that is instituted in pursuance of the provisions of this code.

## **SECTION 106 APPROVAL**

**[A] 106.1 Modifications.**

Whenever there are practical difficulties involved in carrying out the provisions of this code, the *code official* shall have the authority to grant modifications for individual cases upon application of the *owner* or *owner's* authorized agent, provided that the *code official* shall first find that special individual reason makes the strict letter of this code impractical, the modification is in compliance with the intent and purpose of this code and that such modification does not lessen health, life and fire safety requirements. The details of action granting modifications shall be recorded and entered in the department files.

**[A] 106.2 Alternative materials, design and methods of construction and equipment.**

The provisions of this code are not intended to prevent the installation of any material or to prohibit any design or method of construction not specifically prescribed by this code, provided that any such alternative has been *approved*. An alternative material, design or method of construction shall be *approved* where the *code official* finds that the proposed design is satisfactory and complies with the intent of the provisions of this code, and that the material, method or work offered is, for the purpose intended, not less than the equivalent of that prescribed in this code in quality, strength, effectiveness, fire resistance, durability and safety. Where the alternative material, design or method of construction is not



*approved*, the *code official* shall respond in writing, stating the reasons why the alternative was not *approved*.

**[A] 106.3 Required testing.**

Whenever there is insufficient evidence of compliance with the provisions of this code or evidence that a material or method does not conform to the requirements of this code, or in order to substantiate claims for alternative materials or methods, the *code official* shall have the authority to require tests to be made as evidence of compliance without expense to the jurisdiction.

**[A] 106.3.1 Test methods.**

Test methods shall be as specified in this code or by other recognized test standards. In the absence of recognized and accepted test methods, the *code official* shall be permitted to approve appropriate testing procedures performed by an *approved agency*.

**[A] 106.3.2 Test reports.**

Reports of tests shall be retained by the *code official* for the period required for retention of public records.

**[A] 106.4 Used material and equipment.**

Materials that are reused shall comply with the requirements of this code for new materials. Materials, equipment and devices shall not be reused unless such elements are in good repair or have been reconditioned and tested where necessary, placed in good and proper working condition and *approved* by the *code official*.

**[A] 106.5 Approved materials and equipment.**

Materials, equipment and devices *approved* by the *code official* shall be constructed and installed in accordance with such approval.

**[A] 106.6 Research reports.**

Supporting data, where necessary to assist in the approval of materials or assemblies not specifically provided for in this code, shall consist of valid research reports from *approved* sources.

**SECTION 107  
APPEALS AND VARIANCES**

**[A] 107.1 Appeals.**

- A. Any person aggrieved by a decision or order of the *code official* shall have the right to appeal that matter to the Property Maintenance Board. To do this, a printed or typed written notice of appeal must be signed by that person and filed with the office of the City Manager within 14 days after the date service of the decision or order had been completed.
- B. An appeal shall be a means of obtaining a hearing on a contention that the *code official* misinterpreted or misapplied some provision of this code.
- C. The notice of appeal shall specify the decision or order appealed from and shall set forth the grounds of the appeal with particularity.
- D. Stay of proceedings: An appeal shall stay all proceedings on the decision or order from which the appeal is taken, unless the *code official* certifies to the Property Maintenance Board that a stay would cause imminent peril to life or imminent risk of substantial damage to property. In the

event the *code official* so certifies, the proceedings to enforce the order or decision appealed from shall not be stayed, except by an injunction or other equitable order issued by a court, after notice to the city.

- E. Hearing on appeal: The board shall select a reasonable time and place for a hearing on the appeal. Notice of the hearing date shall be given to the appellant and the city in the same manner as service is to be made under Section 111.2.1. If the appellant is not the owner of the property in question, such notice may be given to that property owner in the same manner.
- F. The board may affirm, modify or reverse the order or decision appealed from. The decision of the board on an appeal shall be limited to applying this code; and the board may not disregard, vary or modify the code language. Any such decision of the board shall be deemed to be a final administrative order appealable to the courts. The city shall be deemed to be adversely affected and aggrieved by a board decision which modifies or reverses an order or decision of the *code official*, and the city shall have the right to appeal such a decision to the court. An appeal to court shall stay enforcement proceedings in the same manner as described in subsection D above.

**[A] 107.2 Variances.**

- A. The Property Maintenance Board may, after a public hearing, authorize variances from the requirements of this code.
- B. An application for a variance shall be printed or typewritten, shall be signed by the person requesting the variance, and shall be filed by the owner of the premises with the office of the City Manager. This filing must be made within 14 days after any order or decision of the *code official* was given to a person responsible for compliance with this code. Thereafter, it shall be transmitted, along with all pertinent papers, to the members of the Property Maintenance Board. The application shall set forth the particular requirement from which a variance is requested, and shall be on such form as may be prescribed by the *code official*.
- C. The board shall select a reasonable time and place for a hearing on the variance request. Notice of the time and place of the public hearing shall be published in a newspaper of general circulation in the city not less than 5 nor more than 40 days before the hearing. Such notices shall also be mailed to the variance applicant, to the property owner of record, and to owners of other parcels of real estate within 200 feet of any portion of the subject premises.
- D. Standards for variances: No variance shall be granted unless the board makes findings of fact that:
  - 1. Granting the variance will not impair an adequate supply of light or air to adjacent properties;
  - 2. Granting the variance will not significantly increase the danger of fire or structural collapse nor significantly impair the health, safety, morals or welfare of the occupants or the public;
  - 3. Granting the variance will eliminate peculiar and practical difficulties or undue hardship which would otherwise result upon the owner or operator of the premises if the terms of this code were applied without such variance;
  - 4. Granting the variance will not create blight or constitute a blighting influence on adjoining properties, tending to lead to progressive deterioration and downgrading of the neighborhood;

5. Granting the variance will not diminish or impair the standards of maintenance in this city, the value of the subject property, or property values in the surrounding area; and
6. Strict enforcement of the code requirements would not further the interests of justice, and would be contrary to the spirit and purpose of this code or contrary to the public interest.

In granting a variance, the board may specify the manner and time within which the variance shall be carried out, and may require other improvements or safeguards or the performance of conditions deemed necessary to further and/or respect the intent of this code. A variance decision of the board shall be deemed to be a final administrative order, appealable to the courts. The city shall be deemed to be adversely affected by a board decision granting a variance, and the city shall have the right to appeal such a decision to the court. Any appeal shall stay the effect of the variance decision until the court case is terminated.

**[A] 107.3 Fees for Appeals and Variances.**

Fees for variances and appeals under this Property Maintenance Code shall be as set forth in the general fee schedule for this city, as adopted under Section 153 of the Oakwood Administrative Code and amended from time to time.

## **SECTION 108 PROPERTY MAINTENANCE BOARD**

**[A] 108.1 Creation and Membership.**

A Property Maintenance Board is hereby created. It shall consist of persons appointed by the City Council as members, three (3) residing in each of the official voting precincts of the city of Oakwood. At the time this Property Maintenance Code is enacted, there are eight (8) voting precincts, meaning the board shall consist of twenty four (24) members, three (3) from each precinct. In the event that the number of official voting precincts should increase or decrease, the total number of board members shall change accordingly, provided there shall still be three (3) members from each precinct. Also at the time this Property Maintenance Code is enacted, there is an existing Property Maintenance Board consisting of fifteen (15) members. In the interest of continuity, those members shall continue to serve on the board created hereunder, to the extent that their places of residence comport to the precinct distribution described in this paragraph, for the remainder of the term for which they were originally appointed. In the event that any existing board member cannot be retained, due to place of residence, voting precinct locations, or for other reasons, City Council may terminate that member's existing term and appoint replacements as appropriate to effectuate this provision.

**[A] 108.2 Term of Office.**

The terms of board members shall be for 5 years. Appointments shall be attempted to be made in such a manner that the term of no more than one member from any one district shall expire in any one calendar year. If any member resigns, dies or moves out of the district from which that member was appointed, a replacement member shall be appointed by the City Council for the balance of the unexpired term of office.

**[A] 108.3 Duties, Quorum, and Voting.**

The board shall have the duty to hear and decide all appeals and variances filed under this code, and shall also be responsible for authorizing the issuance of a citation by the city when an owner, occupant or agent fails to take remedial action to correct code violations within a reasonable period of time as determined by the *code official*. The three members from each voting precinct shall constitute the Property Maintenance Board for the purpose of hearing appeals and variances and authorizing the issuance of citations regarding

property in that precinct. If one or more of those three persons is unable to serve, any one or more of the remaining members of the board may be designated by the chairperson as replacement(s) so as to provide three persons to hear and decide each case. A majority of the full board of 15 members shall select a chairperson. Decisions of the board on any appeal or variance shall be made by a majority vote of the three person panel. Failure to obtain a majority vote to reverse or modify a decision or order appealed from shall constitute affirmance of that order. Similarly, failure to obtain a majority vote to grant a variance shall constitute denial of the variance.

**[A] 108.2 Burden of Proof.** The person who files an appeal or a request for a variance shall have the burden of proving by a preponderance of the evidence that his appeal or variance should be granted. The board shall have subpoena power to compel attendance of witnesses.

## **SECTION 109 VIOLATIONS**

### **[A] 109.1 Unlawful acts.**

- A. It shall be unlawful for a person, firm or corporation to be in conflict with or in violation of any of the provisions of this code.
- B. Specific unlawful acts under this code shall include but are not limited to the following:
  - 1. Transfer of legal or equitable ownership of premises without having obtained a pre-sale inspection to the extent required under this code, or without furnishing the proposed new owner a true copy of any conditional certificate of occupancy or other notice of violation and obtaining a signed receipt for it, as required by this code;
  - 2. With respect to rented premises, change of tenant without having obtained a rental inspection to the extent required under this code;
  - 3. Occupancy or use of any premises by a new owner or tenant without that owner or tenant having obtained from the code official (or from the previous owner) a valid certificate of occupancy for the premises, as required by this code.
  - 4. Failure to timely submit the information required by Section 800.3.
  - 5. Operating, letting, listing, advertising, or otherwise making available, any residential property in the city of Oakwood for transient rental purposes, as prohibited by this code.
- C. It shall be a separate unlawful act for any person, firm or corporation (who previously committed an unlawful act as described in paragraph A or B above, the contents of which are incorporated herein by reference) to commit a second such act, whether contrary to or in violation of exactly the same or some other requirement of this code, within 5 years after conviction of the previous unlawful act under paragraph A or B.
- D. It shall be a separate unlawful act for any person, firm or corporation (who previously committed an unlawful act as described in paragraph A or B above, the contents of which are incorporated herein by reference) to commit a third or subsequent act, whether contrary to or in violation of the same or some other requirement of this code, within 10 years after conviction of the previous unlawful act under paragraph A or B.

### **[A] 109.2 Notice of violation.**

The *code official* shall serve a notice of violation or order in accordance with Section 111.4.

### **[A] 109.3 Prosecution of violation.**

Any person failing to comply with a notice of violation or order served in accordance with Section 111.4

shall be deemed guilty of a misdemeanor or civil infraction as determined by the local municipality, and the violation shall be deemed a *strict liability offense*. If the notice of violation is not complied with, the *code official* shall institute the appropriate proceeding at law or in equity to restrain, correct or abate such violation, or to require the removal or termination of the unlawful *occupancy* of the *structure* in violation of the provisions of this code or of the order or direction made pursuant thereto. Any action taken by the authority having jurisdiction on such *premises* shall be charged against the real estate upon which the *structure* is located and shall be a lien upon such real estate.

**[A] 109.4 Violation penalties.**

Any person who shall violate a provision of this code, or fail to comply therewith, or with any of the requirements thereof, shall be prosecuted within the limits provided by state or local laws. Each day that a violation continues after a duly-noticed deadline for compliance shall be deemed a separate offense.

Furthermore:

- A. Whoever commits an unlawful act as described in paragraph A or B of Section 109.1 shall be guilty of an unclassified misdemeanor.
- B. Whoever commits an unlawful act as described in paragraph C of Section 109.1 shall be guilty of a fourth degree misdemeanor.
- C. Whoever commits an unlawful act as described in paragraph D of Section 109.1 shall be guilty of a third degree misdemeanor.

**[A] 109.5 Abatement of violation.**

The imposition of the penalties herein prescribed shall not preclude the City Attorney from instituting appropriate action to restrain, correct or abate a violation, or to prevent illegal *occupancy* of a building, *structure* or *premises*, or to stop an illegal act, conduct, business or utilization of the building, *structure* or *premises*.

**SECTION 110  
STOP WORK ORDER**

**[A] 110.1 Authority.**

Where the *code official* finds any work regulated by this code being performed in a manner contrary to the provisions of this code or in a dangerous or unsafe manner, the *code official* is authorized to issue a stop work order.

**[A] 110.2 Issuance.**

The stop work order shall be in writing and shall be given to the *owner* of the property, to the *owner's* authorized agent, or to the person performing the work. Upon issuance of a stop work order, the cited work shall immediately cease. The stop work order shall state the reason for the order and the conditions under which the cited work is authorized to resume.

**[A] 110.3 Emergencies.**

Where, in the opinion of the *code official*, an emergency exists, the *code official* shall not be required to give a written notice prior to stopping the work.

**[A] 110.4 Failure to comply.**

Any person who shall continue any work after having been served with a stop work order, except such

work as that person is directed to perform to remove a violation or unsafe condition, shall be subject to fines established by the authority having jurisdiction.

## **SECTION 111 UNSAFE, HAZARDOUS, OR UNLAWFUL PREMISES AND STRUCTURES**

### **111.1 Unsafe conditions.**

When a *structure* or equipment or premises is found by the *code official* to be unsafe, or when a *structure* is found unfit for human *occupancy*, the same may be *condemned* pursuant to the provisions of this code.

#### **111.1.1 Unsafe structures or premises.**

An unsafe *structure* or *premises* is one that is found to be dangerous to the life, health, property or safety of the public or the *occupants* of the *structure* by not providing minimum safeguards to protect or warn *occupants* in the event of fire, or because such *structure* contains unsafe equipment or is so damaged, decayed, dilapidated, structurally unsafe or of such faulty construction or unstable foundation, that partial or complete collapse is possible.

#### **111.1.2 Unsafe equipment.**

Unsafe equipment includes any boiler, heating equipment, elevator, moving stairway, electrical wiring or device, flammable liquid containers or other equipment on the *premises* or within the *structure* that is in such disrepair or condition that such equipment is a hazard to life, health, property or safety of the public or *occupants* of the *premises* or *structure*.

#### **111.1.3 Structure unfit for human occupancy.**

A *structure* is unfit for human *occupancy* whenever the *code official* finds that such *structure* is unsafe, unlawful or, because of the degree to which the *structure* is in disrepair or lacks maintenance, is insanitary, vermin or rat infested, contains filth and contamination, or lacks *ventilation*, illumination, sanitary or heating facilities or other essential equipment required by this code, or because the location of the *structure* constitutes a hazard to the *occupants* of the *structure* or to the public. Notwithstanding the foregoing, every *premises* is deemed to be unfit for human occupancy if its condition is such that it constitutes a violation of the following sections of this code:

- A. Chapter Three, General Requirements;
- B. Chapter Four, Light, Ventilation and Occupancy Limitations;
- C. Chapter Five, Plumbing Facilities and Fixture Requirements;
- D. Chapter Six, Mechanical and Electrical Requirements; or
- E. Chapter Seven, Fire Safety Requirements.

A *structure* found to be unfit for human occupancy or use under this section shall be deemed to be an unsafe *structure*.

#### **111.1.4 Unlawful structure.**

An unlawful *structure* is one found in whole or in part to be occupied by more persons than permitted under this code, or was erected, altered or occupied contrary to law.

#### **111.1.5 Dangerous structure or premises.**

For the purpose of this code, any *structure* or *premises* that has any or all of the conditions or defects described as follows shall be considered to be dangerous:

1. Any door, aisle, passageway, stairway, exit or other means of egress that does not conform to the *approved* building or fire code of the jurisdiction as related to the requirements for existing buildings.
2. The walking surface of any aisle, passageway, stairway, exit or other means of egress is so warped, worn loose, torn or otherwise unsafe as to not provide safe and adequate means of egress.
3. Any portion of a building, *structure* or appurtenance that has been damaged by fire, earthquake, wind, flood, *deterioration*, *neglect*, abandonment, vandalism or by any other cause to such an extent that it is likely to partially or completely collapse, or to become *detached* or dislodged.
4. Any portion of a building, or any member, appurtenance or ornamentation on the exterior thereof that is not of sufficient strength or stability, or is not so *anchored*, attached or fastened in place so as to be capable of resisting natural or artificial loads of one and one-half the original designed value.
5. The building or *structure*, or part of the building or *structure*, because of dilapidation, *deterioration*, decay, faulty construction, the removal or movement of some portion of the ground necessary for the support, or for any other reason, is likely to partially or completely collapse, or some portion of the foundation or underpinning of the building or *structure* is likely to fail or give way.
6. The building or *structure*, or any portion thereof, is clearly unsafe for its use and *occupancy*.
7. The building or *structure* is *neglected*, damaged, dilapidated, unsecured or abandoned so as to become an attractive nuisance to children who might play in the building or *structure* to their danger, becomes a harbor for vagrants, criminals or immoral persons, or enables persons to resort to the building or *structure* for committing a nuisance or an unlawful act.
8. Any building or *structure* has been constructed, exists or is maintained in violation of any specific requirement or prohibition applicable to such building or *structure* provided by the *approved* building or fire code of the jurisdiction, or of any law or ordinance to such an extent as to present either a substantial risk of fire, building collapse or any other threat to life and safety.
9. A building or *structure*, used or intended to be used for dwelling purposes, because of inadequate maintenance, dilapidation, decay, damage, faulty construction or arrangement, inadequate light, *ventilation*, mechanical or plumbing system, openness to the elements and/or inclement weather and/or animal infestation, or otherwise, is determined by the *code official* to be unsanitary, unfit for human habitation or in such a condition that is likely to cause sickness or disease.
10. Any building or *structure*, because of a lack of sufficient or proper fire-resistance-rated construction, fire protection systems, electrical system, fuel connections, mechanical system, plumbing system or other cause, is determined by the *code official* to be a threat to life or health.

11. Any portion of a building remains on a site after the demolition or destruction of the building or *structure* or whenever any building or *structure* is abandoned so as to constitute such building or portion thereof as an attractive nuisance or hazard to the public.

#### **111.1.6 Unlawful structure or premises.**

Unlawful premises are those determined by the code official to be in whole or in part in violation of any of the sections of this Property Maintenance Code. All properties which are unsafe, unfit for human occupancy or otherwise in violation of the Property Maintenance Code may be declared as public nuisances under the common law and laws of Ohio. Such unlawful premises constitute public nuisances by virtue of the injury and annoyance they cause to the public and the damage they do to public interests. That injury, annoyance or damage results from the negative impact of blight, deteriorated, defective, and unlawful premises due to physical decay, neglect, unlawful use, and/or lack of maintenance. Such deterioration is caused by physical decay, neglect, extensive use, or lack of maintenance. It produces effects such as, but not limited to, holes, breaks, cracking, peeling, and rusting.

### **111.2 Repair, closing or removal of unsafe, hazardous, or unlawful nuisance conditions.**

#### **111.2.1 Unsafe, hazardous conditions – repair, closing or removal.**

The *code official* shall give notice to order the owner of any premises (and/or the holders of legal and/or equitable liens upon that premises) declared by that official to be all or partly unsafe to perform such repairs as necessary to make that premises safe, to secure any insecure structure, to close any open and vacant structure, or, in the alternative, to demolish and remove that structure or the unsafe aspect of the premises. Any permits required by the Building Code or Zoning Code of this city for such repair or demolition work must be obtained before such work is commenced. The notice giving this order shall comply with the requirements of Section 111.4 and shall allow a reasonable time for such corrective work or demolition and removal, including adequate time to obtain permits, and in non-emergency situations shall provide notice at least 30 days in advance of proposed entry onto the premises by the city to perform that work. The notice referred to in this section shall be in addition to, and may be combined with, the order to vacate which may be issued for any unsafe premises as directed by Section 111.1.3.

#### **111.2.2 Unlawful premises – repair.**

With regard to unlawful premises constituting public nuisances (as defined herein), the *code official* shall follow the same notice procedures as described immediately above in Section 111.2.1 to order that the unlawful conditions be repaired or removed.

The notice and order with regard to unlawful premises shall not provide the alternative of demolition and removal and shall not be combined with any order to vacate, because such orders to demolish and remove or to vacate may be issued only for unsafe rather than unlawful premises.

#### **111.2.3 Failure to comply.**

Whenever there has been failure to comply, within the time required, with an order issued under this Section 111.2 of the code, the *code official* may cause the work to be performed by the city or by contract or arrangement with private persons. Any such contract or arrangements with private persons shall comply with city charter and ordinance requirements as to making contracts or financial commitments on behalf of the city. Such a failure to comply means not only a failure to complete the work within the required time but also failure to use the alternative procedure of entering into a contract with the city within the required time, guaranteed by a sufficient surety, to perform the work at a later date.



#### **111.2.4 Real estate tax lien, civil lawsuit, for costs incurred by city.**

The cost of work required to be performed through an order referred to in Section 111.2 shall be certified by the clerk of the City Council to the county auditor as a tax lien in the manner prescribed in Ohio Revised Code 715.261; and/or the city may commence a civil lawsuit to recover those costs.

#### **111.3 Authority to disconnect service utilities.**

The *code official* shall have the authority to authorize disconnection of utility service to the building, *structure* or system regulated by this code and the referenced codes and standards set forth in Section 102.8 in case of emergency where necessary to eliminate an immediate hazard to life or property or where such utility connection has been made without approval. The *code official* shall notify the serving utility and, whenever possible, the *owner* or *owner's* authorized agent and *occupant* of the building, *structure* or service system of the decision to disconnect prior to taking such action. If not notified prior to disconnection the *owner*, *owner's* authorized agent or *occupant* of the building *structure* or service system shall be notified in writing as soon as practical thereafter.

#### **111.4 Notice.**

Whenever the *code official* determines that there has been a violation of this code or has grounds to believe that a violation has occurred, notice shall be given in the manner prescribed in Sections 111.4.1 and 111.4.2 to the owner or the owner's authorized agent, for the violation as specified in this code. Notices for condemnation procedures shall comply with this section.

##### **111.4.1 Form.**

Such notice shall be in accordance with all of the following:

1. Be in writing.
2. Include a description of the real estate sufficient for identification.
3. Include a statement of the violation or violations and why the notice is being issued.
4. Include a correction order allowing a reasonable time to make the repairs and improvements required to bring the *dwelling unit* or *structure* into compliance with the provisions of this code.
5. Inform the property *owner* or *owner's* authorized agent of the right to appeal.
6. Include a statement of the right to file a lien in accordance with Section 109.3.
7. If the notice is in the form of a conditional occupancy certificate (resulting from a pre-sale or rental inspection under this Code) which lists aspects of the premises not in compliance with other sections of this code, it shall include an explanation of the certificate of occupancy procedures and the possibility of the owner shifting responsibility for correcting those unsafe or unlawful items to the new owner through a written agreement between the parties as provided under this Code.
8. The notice of any violation and of the requirement that it be corrected shall provide at least 30 days prior notice of the fact that, if the corrective work has not been completed within the

reasonable time allowed in the correction order which is part of the notice, the city may elect to enter upon the premises under authority of this Code to perform the work required by the notice. Such advance notice may be reduced or dispensed with as explained in Section 112 dealing with emergency situations. This type of advance notice provides a basis for the city to recover (through the procedures described in Ohio Revised Code 715.261) any costs it may incur in correcting unsafe structures or hazardous conditions or abating unlawful conditions as nuisances.

9. The notice shall give an explanation of the fact that, as an alternative to performing the correction work within the reasonable time allowed in the notice (and to avoid the city entering upon the property to perform that work if the owner fails to do so), the owner or any lienholder of record may enter into a written contract with the city in which that owner or lienholder gives a written promise, guaranteed by a sufficient surety (as described below), that the work will be completed within such additional reasonable time as may be agreed to between those parties. Such a sufficient surety must be a performance bond, letter of credit or cash deposited with the city in the amount of one and one-half times the cost of the work, as reasonably estimated by the city, with the terms, conditions and issuing company or bank to be satisfactory to the city attorney.
10. The notice shall include an explanation of the intention of the city to recover the costs it may incur in correcting such unsafe, hazardous, or unlawful nuisance conditions through certifying those costs to the county auditor to be placed as a real estate tax lien against the premises (under Ohio Revised Code 715.261 as referred to above) and/or to commence a civil lawsuit to recover those costs from the owner and/or to use other legal remedies to enforce this code.

#### **111.4.2 Method of service.**

Such notice shall be deemed to be properly served where a copy thereof is served in accordance with any one or more of the following methods, reasonably calculated to reach the *owner*, *owner's* agent, or person responsible for the premises or structure:

1. A copy is delivered personally.
2. A copy is sent by certified or registered mail addressed to the *owner* at the last known address with the return receipt requested.
3. A copy is posted in a conspicuous location at the subject property.
4. A notice, in summary form, is published in a newspaper of general circulation within the city.
5. A copy is serviced personally or residentially by an officer of the Public Safety Department of the city.
6. A notice is sent by electronic mail, where the email address of the *owner* or *owner's* authorized agent is known.

Service of such notice in the foregoing manner upon the *owner's* agent or upon the person responsible for the premises or structure shall constitute service of notice upon the owner.

**111.5 Unauthorized tampering.**

Signs, tags or seals posted or affixed by the *code official* shall not be mutilated, destroyed or tampered with, or removed without authorization from the *code official*.

**111.6 Transfer of ownership.**

It shall be unlawful for the *owner* of any *dwelling unit* or *structure* who has received a compliance order or upon whom a notice of violation has been served to sell, transfer, mortgage, lease or otherwise dispose of such *dwelling unit* or *structure* to another until the provisions of the compliance order or notice of violation have been complied with, or until such *owner* or the *owner's* authorized agent shall first furnish the grantee, transferee, mortgagee or lessee a true copy of any compliance order or notice of violation issued by the *code official* and shall furnish to the *code official* a signed and notarized statement from the grantee, transferee, mortgagee or lessee, acknowledging the receipt of such compliance order or notice of violation and fully accepting the responsibility without condition for making the corrections or repairs required by such compliance order or notice of violation.

**111.6.1 Pre-sale inspection program and Certificate of Occupancy required for new owners and tenants.**

- A. It shall be unlawful for the owner of any real estate premises to transfer legal or equitable ownership of that premises ("title"), or change of tenant, without having obtained a pre-sale inspection of it under this code. This inspection will enable the code official to work toward accomplishing the purposes of this code by listing any repairs or other work necessary to eliminate any unsafe or hazardous conditions, to comply with applicable requirements of the Fire Code, Zoning Code and other ordinances, and also to correct any unlawful nuisance conditions in the form of violations of this Property Maintenance Code. Such an inspection and list shall be part of the process of issuing the required certificate of occupancy.
- B. Application for a pre-sale inspection shall be made on such form and in such manner as may be prescribed from time to time by the code official. The city may charge a fee for this service as provided for under Chapter 153.
- C. Within 21 days after application was made for a pre-sale inspection, the code official shall have completed the inspection, compiled a list of any items to be brought into compliance with this code and applicable provisions of the Fire Code, Zoning Code and other ordinances, and shall have issued a violation letter to the owner or lienholder of a premises. This period of time may be extended by the code official if a delay is caused by any matter beyond the reasonable control of that official.
- D. A certificate of occupancy shall be valid for one year after the violations have been corrected to the satisfaction of the code official or until 60 days after the premises may be transferred to a new owner or tenant, whichever occurs sooner.
- E. Any rental unit inspection required under this chapter may be waived by the code official, and an occupancy certificate may be granted without such inspection, so long as all of the following conditions are met:
  - 1. The subject property has already undergone a pre-sale or rental unit inspection during the twelve (12) months immediately prior to the most recent change of tenant;

2. The city has not received any zoning or property maintenance complaints about the subject property during the twelve (12) months immediately prior to the most recent change of tenant; and
  3. The property owner is otherwise in compliance with all requirements of this Property Maintenance Code, including but not limited to the timely provision of Tenant Information forms with each change of tenant at the property.
- F. If the owner, occupant, or agent thereof does not consent to the proposed inspection, the code official may appear before any judge in a court of competent jurisdiction and seek an administrative search warrant to allow an inspection. Any such application shall be made within ten (10) calendar days after the nonconsent. The application for the warrant shall specify the basis upon which the warrant is being sought and shall include a statement that the inspection will be limited to a determination whether there are violations of the code provisions identified in this section. The court may consider any of the following factors along with such other matters as it deems pertinent in its decision as to whether a warrant shall issue:
1. Eyewitness account of violation;
  2. Citizen complaints;
  3. Tenant complaints;
  4. Plain view violations;
  5. Violations apparent from city records;
  6. Property deterioration;
  7. Age of property;
  8. Nature of alleged violation;
  9. Condition of similar properties in the area;
  10. Documented violations on similar properties in the area;
  11. Passage of time since last inspection;
  12. Previous violations on the property.

If a warrant is issued, no owner, occupant, or agent thereof shall fail or neglect, upon presentation of a warrant, to properly permit entry therein by the code official or his/her duly authorized designee for the purpose of inspection and examination pursuant to this section and consistent with the terms of the warrant. If the court declines to issue a warrant, or if no warrant is sought, the inspection shall still take place but the scope thereof shall be limited to such areas as are in plain view. A limited-scope inspection conducted pursuant to this paragraph shall be considered an “inspection” for all purposes of the pre-sale inspection program set forth in this section. No criminal penalty shall attach, nor shall any certificate of occupancy be denied, solely by reason of the owner’s, occupant’s, or agent’s refusal to consent to a full inspection.

A certificate of occupancy signed by the code official shall be evidence that the premises complies with the requirements of this code and all other applicable ordinances, provided however, that if a limited-scope inspection is conducted pursuant to subsection E above, the certificate of occupancy shall note that fact and shall not constitute evidence of code compliance as to any uninspected portions of the premises. If the inspection disclosed aspects of the property not in compliance, the certificate shall be merely a conditional certificate of occupancy. The condition shall be that the defective aspects of the premises must be brought into compliance with this code within such reasonable length of time as may be set forth in the certificate.

Such a conditional certificate shall be deemed to be a notice under this code that the premises and its owners are in violation of this code or other applicable ordinances and that the unsafe, hazardous, or unlawful conditions must be corrected. The certificate shall constitute a notice, as referred to in Section 111.4, and shall include all matters required by that section.

**111.6.2 Responsibility for making repairs.**

The responsibility for making repairs or completing such work as may be necessary to correct any defective aspects of the premises shall rest upon the person who was the owner immediately prior to the inspection which was the basis for the notice. Such responsibility may be shifted to a new owner by a written agreement in which that new owner assumes the responsibility, after having been given a copy of the conditional certificate of occupancy including the list of violations. A signed copy of such an agreement shall be filed with the code official. A written assumption by the new owner shall release the previous owner from responsibility to the city under this code.

If responsibility is so assumed, the new owner shall be obligated to comply with the requirements of the conditional certificate of occupancy within the time required by the code official.

A new owner who does not assume such responsibility but instead relies upon the prior owner being obligated to correct violations identified during an inspection of the premises takes the risk that the prior owner may fail to do so as and when required. If that occurs, the new owner is at risk because any unsafe structure on the premises must be ordered to be vacated under provisions of this code. Further, the conditional certificate of occupancy constitutes a repair, closing or removal order under other provisions of this code, to remedy any unsafe, hazardous or any unlawful nuisance condition, with the expenses of such a procedure to be assessed against the premises as part of real estate taxes on that property.

**111.6.3 City utility bills to be paid immediately as a condition of occupancy certificate.**

To obtain either a certificate of occupancy or a conditional certificate of occupancy, all outstanding water and sewer bills for the property must be paid at once and in full.

**111.6.4 Certificate of Occupancy required for new owner.**

It shall be unlawful for any person who acquires legal or equitable title to a premises (after the date this Property Maintenance Code is adopted) to occupy or to use it without having obtained from the code official or the previous owner a valid certificate of occupancy (absolute or conditional) for that premises. A certificate of occupancy is valid for only one year after its date or until 60 days after title to the premises is transferred to a new owner, whichever occurs sooner. No new occupancy certificate shall be issued for the premises without a new inspection (which may or may not reveal and require correction of additional unsafe or unlawful matters).

**111.6.5 Disclosure of violations to new owner.**

It shall be unlawful for the owner of any property upon whom a notice of violation has been served (in the form of a list of defects or violations attached to a conditional certificate of occupancy or as a result of violations otherwise noted by the code official) to transfer legal or equitable ownership of the property to another until the defects and violations listed in that notice have been corrected, or until the owner or a lienholder has entered into a satisfactory written contract to make the corrections, or until such owner furnishes the proposed new owner a true copy of that notice and obtains a signed receipt that he has done so and that the proposed new owner is aware of the pending notice and its requirement of corrective work.

**111.6.6 Business inspections.**

Pre-sale and rental inspections are applicable to business uses and shall be conducted upon a change of tenant or ownership.

All inspections must be conducted as soon as reasonably practical after being vacated by tenants or in contemplation of a change in ownership as required by this Code. Such commercial rental units must be brought into compliance with requirements of this Property Maintenance Code in connection with each change of occupancy by new tenants.

**111.6.7 Inspection fees.**

Fees to be charged for pre-sale inspections (and similar inspections made of rental units after tenants vacate those units), shall be as set by the City Manager in the fee schedule issued under Chapter 153 of the Administrative Code. Said fees shall be paid at the time an individual requests a pre-sale inspection and no pre-sale inspection shall be conducted until such time as the appropriate fee is received by the city.

**111.7 Placarding.**

Upon failure of the *owner*, *owner's* authorized agent or person responsible to comply with the notice provisions within the time given, the *code official* shall post on the *premises* or on defective equipment a placard bearing the word "Condemned" and a statement of the penalties provided for occupying the *premises*, operating the equipment or removing the placard. Such notice shall be posted in a conspicuous place in or about the structure affected by such notice. If the notice pertains to equipment, it shall be placed on the condemned equipment.

**111.7.1 Placard removal.**

The *code official* shall remove the condemnation placard whenever the defect or defects upon which the condemnation and placarding action were based have been eliminated. Any person who defaces or removes a condemnation placard without the approval of the *code official* shall be subject to the penalties provided by this code.

**111.8 Prohibited occupancy.**

Any occupied *structure condemned* and placarded by the *code official* shall be vacated as ordered by the *code official*. Any person who shall occupy a placarded *premises* or shall operate placarded equipment, and any *owner or owner's* authorized agent who shall let anyone occupy a placarded *premises* or operate placarded equipment shall be liable for the penalties provided by this code.

**111.9 Restoration or abatement.**

The structure or equipment determined to be unsafe by the code official is permitted to be restored to a safe condition. The *owner*, *owner's* authorized agent, *operator* or *occupant* of a structure, *premises* or equipment deemed unsafe by the *code official* shall abate or cause to be abated or corrected such unsafe conditions either by repair, rehabilitation, demolition or other *approved* corrective action. To the extent that repairs, alterations, or additions are made or a change of occupancy occurs during the restoration of the structure, such repairs, alterations, additions, or change of occupancy shall comply with the requirements of the *International Existing Building Code*.

## SECTION 112 EMERGENCY MEASURES

### **112.1 Imminent danger.**

When, in the opinion of the *code official*, there is *imminent danger* of failure or collapse of a building or *structure* that endangers life, or when any *structure* or part of a *structure* has fallen and life is endangered by the occupation of the *structure*, or when there is actual or potential danger to the building *occupants* or those in the proximity of any *structure* because of explosives, explosive fumes or vapors or the presence of toxic fumes, gases or materials, or operation of defective or dangerous equipment, the *code official* is hereby authorized and empowered to order and require the *occupants* to vacate the *premises* forthwith. The *code official* shall cause to be posted at each entrance to such *structure* a notice reading as follows: “This Structure Is Unsafe and Its Occupancy Has Been Prohibited by the Code Official.” It shall be unlawful for any person to enter such *structure* except for the purpose of securing the structure, making the required repairs, removing the hazardous condition or of demolishing the same.

### **112.2 Temporary safeguards.**

Notwithstanding other provisions of this code, whenever, in the opinion of the *code official*, there is *imminent danger* due to an unsafe condition, the *code official* shall order the necessary work to be done, including the boarding up of openings, to render such *structure* temporarily safe whether or not the legal procedure herein described has been instituted; and shall cause such other action to be taken as the *code official* deems necessary to meet such emergency.

### **112.3 Closing streets.**

When necessary for public safety, the *code official* shall temporarily close structures and close, or order the authority having jurisdiction to close, sidewalks, streets, *public ways* and places adjacent to unsafe structures, and prohibit the same from being utilized.

### **112.4 Emergency repairs.**

For the purposes of this section, the *code official* shall employ the necessary labor and materials to perform the required work as expeditiously as possible.

### **112.5 Costs of emergency repairs.**

Costs incurred in the performance of emergency work shall be paid by the jurisdiction, subject to compliance with city charter and ordinance requirements as to making contracts or financial commitments on behalf of the city. The legal counsel of the jurisdiction may institute appropriate action against the *owner* of the *premises* or *owner’s* authorized agent where the unsafe *structure* is or was located for the recovery of such costs. The costs of such emergency repairs to correct hazardous conditions shall be certified by the clerk of the city council to the county auditor as a tax lien upon the premises in the manner provided in Ohio Revised Code 715.261. Based on the emergency nature of such costs, notice to owners and lienholders of the emergency work may be given by other than certified mail, may be given with less than the advance otherwise required, or may be dispensed with entirely. If no advance notice at all is given, however, the lien authorized by R.C. 715.261 for such costs shall be subordinate to any liens of prior record.

### **112.6 Hearing.**

Any person ordered to take emergency measures shall comply with such order forthwith. Any affected person shall thereafter, upon petition directed to the appeals board, be afforded a hearing as described in this code.

## **SECTION 113 DEMOLITION**

### **113.1 General.**

The *code official* shall order the *owner* or *owner's* authorized agent of any *premises* upon which is located any *structure*, which in the *code official's* or *owner's* authorized agent judgment after review is so deteriorated or dilapidated or has become so out of repair as to be dangerous, unsafe, insanitary or otherwise unfit for human habitation or *occupancy*, and such that it is unreasonable to repair the *structure*, to demolish and remove such *structure*; or if such *structure* is capable of being made safe by repairs, to repair and make safe and sanitary, or to board up and hold for future repair or to demolish and remove at the *owner's* option; or where there has been a cessation of normal construction of any *structure* for a period of more than two years, the *code official* shall order the *owner* or *owner's* authorized agent to demolish and remove such *structure*, or board up until future repair. Boarding the building up for future repair shall not extend beyond thirty days, unless *approved* by the building official. Demolition shall require all permits required under Chapter 1303 of the Building Code.

### **113.2 Notices and orders.**

Notices and orders shall comply with Section 111.4.

### **113.3 Failure to comply.**

If the *owner* of a *premises* or *owner's* authorized agent fails to comply with a demolition order within the time prescribed, the *code official* shall cause the *structure* to be demolished and removed, either through an available public agency or by contract or arrangement with private persons, and the cost of such demolition and removal shall be charged against the real estate upon which the *structure* is located and shall be a lien upon such real estate.

### **113.4 Salvage materials.**

Where any *structure* has been ordered demolished and removed, the governing body or other designated officer under said contract or arrangement aforesaid shall have the right to sell the salvage and valuable materials. The net proceeds of such sale, after deducting the expenses of such demolition and removal, shall be promptly remitted with a report of such sale or transaction, including the items of expense and the amounts deducted, for the person who is entitled thereto, subject to any order of a court. If such a surplus does not remain to be turned over, the report shall so state.



**SECTION 114  
FIRE INSURANCE TRUST**

**114.1 General.**

Ohio statutes require the creation of a Fire Insurance Trust Fund. The language explaining the requirements of the fund shall read as follows:

- A. A fire insurance trust fund is to be created in the accounting records of the city. It is to be maintained from all other funds of city money, and is to be administered as a trust fund for the purposes described in the remainder of this section. The Director of Finance shall administer this trust fund for the purposes specified in Revised Code 3929.86.
- B. In the event of any loss by fire within the City of Oakwood when the amount of said loss agreed to between the named insured or insureds and the company or companies insuring said loss equals or exceeds 60% of the aggregate limits of liability on all fire policies covering the building or structure insured, the insurance company or companies shall transfer from the insurance proceeds to the Director of Finance of the city in the aggregate \$2,000.00 for each \$15,000.00, and each fraction of that amount, of a claim, or such higher amount as may be required under Revised Code 3929.86(C) or other applicable state law. In the alternative, if at the time of a proof of loss agreed to between the named insured or insureds and the insurance company or companies the named insured or insureds have submitted a contractor's signed estimate of the costs of removing, repairing, or securing the building or other structure, the Director of Finance shall transfer from the insurance proceeds the amount specified in the estimate. This shall be done in accordance with Revised Code 715.26(F).
- C. Such transfer of proceeds shall be on a pro rata basis by all companies insuring the building or other structure. The named insured or insureds may submit a contractor's signed estimate of the costs of removing, repairing or securing the building or other structure after the transfer, and the director of finance shall return the amount of the fund in excess of the estimate to the named insured or insureds, provided that the city has not commenced to remove, repair, or secure the building or other structure.
- D. Upon receipt of proceeds by the city as authorized by this section and by Revised Code 3929.86, the Director of Finance shall place the proceeds in the fire insurance trust fund to be used solely as security against the total cost of removing, repairing, or securing incurred by the city pursuant to R.C. 715.261 or Section 109 dealing with emergency measures of this code. When transferring the funds as required by this section, an insurance company shall provide the Director of Finance with the name and address of the named insured or insureds; and that Director shall contact the named insured or insureds, certify that the proceeds have been received by the City of Oakwood and notify them that the following procedures will be followed:
  - 1. The fund shall be returned to the named insured or insureds when the repairs or removal, or securing of the building or other structure have been completed and the required proof received by the Director of Finance, if the City of Oakwood has incurred any costs for repairs, removal or securing of the building or other structure, such costs shall be paid from the fund and if excess funds remain, the City of Oakwood shall transfer the remaining funds to the named insured or insureds. Nothing in this code shall be construed to limit the ability of the City of Oakwood to recover any deficiency under Section 715.261 of the Ohio Revised Code.
  - 2. Nothing in this section shall be construed to prohibit the City of Oakwood and the named insured or insureds from entering into an agreement that permits the transfer of funds to the named insured or insureds if some other reasonable disposition of the damaged property has been negotiated.

## CHAPTER 2 DEFINITIONS

---

### User note:

*About this chapter: Codes, by their very nature, are technical documents. Every word, term and punctuation mark can add to or change the meaning of a technical requirement. It is necessary to maintain a consensus on the specific meaning of each term contained in the code. Chapter 2 performs this function by stating clearly what specific terms mean for the purpose of the code.*

---

---

### SECTION 201 GENERAL

#### 201.1 Scope.

Unless otherwise expressly stated, the following terms shall, for the purposes of this code, have the meanings shown in this chapter.

#### 201.2 Interchangeability.

Words stated in the present tense include the future; words stated in the masculine gender include the feminine and neuter; the singular number includes the plural and the plural, the singular.

#### 201.3 Terms defined in other codes.

Where terms are not defined in this code and are defined in the *International Building Code, International Existing Building Code, International Fire Code, International Fuel Gas Code, International Mechanical Code, International Plumbing Code, International Residential Code, International Zoning Code* or *NFPA 70*, such terms shall have the meanings ascribed to them as stated in those codes.

**Exception:** When used within this code, the terms unsafe and dangerous shall have only the meanings ascribed to them in this code and shall not have the meanings ascribed to them by the International Existing Building Code.

#### 201.4 Terms not defined.

Where terms are not defined through the methods authorized by this section, such terms shall have ordinarily accepted meanings such as the context implies.

#### 201.5 Parts.

Whenever the words “*dwelling unit*,” “*dwelling*,” “*premises*,” “*building*,” “*rooming house*,” “*rooming unit*,” “*housekeeping unit*” or “*story*” are stated in this code, they shall be construed as though they were followed by the words “or any part thereof.”

## SECTION 202 GENERAL DEFINITIONS

**ANCHORED.** Secured in a manner that provides positive connection.

**APPROVED.** Acceptable to the *code official*.

**BASEMENT.** That portion of a building that is partly or completely below grade.

**BATHROOM.** A room containing plumbing fixtures including a bathtub or shower.

**BEDROOM.** Any room or space used or intended to be used for sleeping purposes in either a dwelling or *sleeping unit*.

**CODE OFFICIAL.** The city manager and also any person(s) to whom the city manager may have delegated the responsibility of administering or enforcing all or any portion of this code.

**CONDEMN.** Condemn means to order to be vacated. Similarly, condemned shall mean ordered to be vacated, and condemnation shall mean vacation.

**COST OF SUCH DEMOLITION OR EMERGENCY REPAIRS.** The costs shall include the actual costs of the demolition or repair of the *structure* less revenues obtained if salvage was conducted prior to demolition or repair. Costs shall include, but not be limited to, expenses incurred or necessitated related to demolition or emergency repairs, such as asbestos survey and abatement if necessary; costs of inspectors, testing agencies or experts retained relative to the demolition or emergency repairs; costs of testing; surveys for other materials that are controlled or regulated from being dumped in a landfill; title searches; mailing(s); postings; recording; and attorney fees expended for recovering of the cost of emergency repairs or to obtain or enforce an order of demolition made by a *code official*, the governing body or board of appeals.

**DETACHED.** When a structural element is physically disconnected from another and that connection is necessary to provide a positive connection.

**DETERIORATION.** To weaken, disintegrate, corrode, rust or decay and lose effectiveness.

**DWELLING UNIT.** A single unit providing complete, independent living facilities for a single family, as defined by the Oakwood Zoning Code, including permanent provisions for living, sleeping, eating, cooking and sanitation.

**[Z] EASEMENT.** That portion of land or property reserved for present or future use by a person or agency other than the legal fee *owner(s)* of the property. The *easement* shall be permitted to be for use under, on or above said lot or lots.

**EMERGENCY ESCAPE AND RESCUE OPENING.** An operable exterior window, door or other similar device that provides for a means of escape and access for rescue in the event of an emergency.

**EQUIPMENT SUPPORT.** Those structural members or assemblies of members or manufactured elements, including braces, frames, lugs, snuggers, hangers or saddles, that transmit gravity load, lateral load and operating load between the equipment and the *structure*.

**EXTERIOR PROPERTY.** The open space on the *premises* and on adjoining property under the control of *owners* or *operators* of such *premises*.

**FAMILY.** As used in this Property Maintenance Code, family shall have the same meaning as is set forth in the Oakwood Zoning Code.

**GARBAGE.** The animal or vegetable waste resulting from the handling, preparation, cooking and consumption of food.

**[BE] GUARD.** A building component or a system of building components located at or near the open sides of elevated walking surfaces that minimizes the possibility of a fall from the walking surface to a lower level.

**[BG] HABITABLE SPACE.** Space in a *structure* for living, sleeping, eating or cooking. *Bathrooms, toilet rooms, closets, halls, storage or utility spaces, and similar areas* are not considered *habitable spaces*.

**[A] HISTORIC BUILDING.** Any building or *structure* that is one or more of the following:

1. Listed or certified as eligible for listing, by the State Historic Preservation Officer or the Keeper of the National Register of Historic Places, in the National Register of Historic Places.
2. Designated as historic under an applicable state or local law.
3. Certified as a contributing resource within a National Register or state or locally designated historic district.

**HOUSEKEEPING UNIT.** A room or group of rooms forming a single *habitable space* equipped and intended to be used for living, sleeping, cooking and eating that does not contain, within such a unit, a toilet, lavatory and bathtub or shower.

**IMMINENT DANGER.** A condition that could cause serious or life-threatening injury or death at any time.

**INFESTATION.** The presence, within or contiguous to, a *structure* or *premises* of insects, rodents, vermin or other pests.

**INOPERABLE MOTOR VEHICLE.** A vehicle that cannot be driven upon the public streets for reason including but not limited to being unlicensed, wrecked, abandoned, in a state of disrepair, or incapable of being moved under its own power; also includes “Junk Vehicle” as defined in Section 523.01 of the General Offenses Code.

**[A] LABELED.** Equipment, materials or products to which have been affixed a label, seal, symbol or other identifying mark of a nationally recognized testing laboratory, *approved* agency or other organization concerned with product evaluation that maintains periodic inspection of the production of the above-*labeled* items and whose labeling indicates either that the equipment, material or product meets identified standards or has been tested and found suitable for a specified purpose.

**LET FOR OCCUPANCY or LET.** To permit, provide or offer possession or *occupancy* of a dwelling, *dwelling unit, rooming unit, building, premise or structure* by a person who is or is not the legal *owner* of record thereof, pursuant to a written or unwritten lease, agreement or license, or pursuant to a recorded or unrecorded agreement of contract for the sale of land.

**NEGLECT.** The lack of proper maintenance for a building or *structure*.

[A] **OCCUPANCY.** The purpose for which a building or portion thereof is utilized or occupied.

**OCCUPANT.** Any individual living or sleeping in a building, or having possession of a space within a building.

**ONE-FAMILY DWELLING.** A building containing one dwelling unit, to be occupied by only one family with no more lodgers or boarders than permitted under the Zoning Code of this city.

**OPENABLE AREA.** That part of a window, skylight or door which is available for unobstructed *ventilation* and which opens directly to the outdoors.

**OPERATOR.** Any person who has charge, care or control of a *structure* or *premises* that is let or offered for *occupancy*.

[A] **OWNER.** Any person, agent, *operator*, firm or corporation having legal or equitable interest in the property; or recorded in the official records of the state, county or municipality as holding title to the property; or otherwise having control of the property, including the guardian of the estate of any such person, and the executor or administrator of the estate of such person if ordered to take possession of real property by a court.

[A] **PERSON.** An individual, corporation, partnership or any other group acting as a unit.

**PEST ELIMINATION.** The control and elimination of insects, rodents or other pests by eliminating their harborage places; by removing or making inaccessible materials that serve as their food or water; by other *approved pest elimination* methods.

[A] **PREMISES.** A lot, plot or parcel of land, *easement* or *public way*, including any structures thereon.

[A] **PUBLIC WAY.** Any street, alley or other parcel of land that: is open to the outside air; leads to a street; has been deeded, dedicated or otherwise permanently appropriated to the public for public use; and has a clear width and height of not less than 10 feet (3048 mm).

**ROOMING HOUSE.** A building arranged or occupied for lodging, with or without meals, for compensation and not occupied as a one- or two-family dwelling.

**ROOMING UNIT.** Any room or group of rooms forming a single habitable unit occupied or intended to be occupied for sleeping or living, but not for cooking purposes.

**RUBBISH.** Combustible and noncombustible waste materials, except garbage; the term shall include the residue from the burning of wood, coal, coke and other combustible materials, paper, rags, cartons, boxes, wood, excelsior, rubber, leather, tree branches, *yard* trimmings, tin cans, metals, mineral matter, glass, crockery and dust and other similar materials.

[A] **SLEEPING UNIT.** A room or space in which people sleep, which can also include permanent provisions for living, eating and either sanitation or kitchen facilities, but not both. Such rooms and spaces that are also part of a *dwelling unit* are not *sleeping units*.

**STRICT LIABILITY OFFENSE.** An offense in which the prosecution in a legal proceeding is not required to prove criminal intent as a part of its case. It is enough to prove that the defendant either did an act which was prohibited, or failed to do an act which the defendant was legally required to do.

**[A] STRUCTURE.** That which is built or constructed.

**TENANT.** A person, corporation, partnership or group, whether or not the legal *owner* of record, occupying a building or portion thereof as a unit.

**TOILET ROOM.** A room containing a water closet or urinal but not a bathtub or shower.

**TWO-FAMILY DWELLING.** A building containing two dwelling units, each to be occupied by only one family with no more lodgers or boarders than permitted under the Zoning Code of this city.

**ULTIMATE DEFORMATION.** The deformation at which failure occurs and that shall be deemed to occur if the sustainable load reduces to 80 percent or less of the maximum strength.

**[M] VENTILATION.** The natural or mechanical process of supplying conditioned or unconditioned air to, or removing such air from, any space.

**WORKMANLIKE.** Executed in a skilled manner; e.g., generally plumb, level, square, in line, undamaged and without marring adjacent work.

**[Z] YARD.** An open space on the same lot with a *structure*.

Unsafe premises is defined in Sec. 111.

## CHAPTER 3 GENERAL REQUIREMENTS

---

### User note:

*About this chapter:* Chapter 3 is broad in scope and includes a variety of requirements for the maintenance of exterior property areas, as well as the interior and exterior elements of the structure, that are intended to maintain a minimum level of safety and sanitation for both the general public and the occupants of a structure, and to maintain a building's structural and weather-resistance performance. Specifically, Chapter 3 contains criteria for the maintenance of building components; vacant structures and land; the safety, sanitation and appearance of the interior and exterior of structures and all exterior property areas; accessory structures; extermination of insects and rodents; access barriers to swimming pools, spas and hot tubs; vehicle storage and owner/occupant responsibilities.

---

### SECTION 301 GENERAL

#### **301.1 Scope.**

The provisions of this chapter shall govern the minimum conditions and the responsibilities of persons for maintenance of structures, equipment and *exterior property*.

#### **301.2 Responsibility.**

The *owner* of the *premises* shall maintain the structures and *exterior property* in compliance with these requirements, except as otherwise provided for in this code. A person shall not occupy as *owner-occupant* or permit another person to occupy *premises* that are not in a sanitary and safe condition and that do not comply with the requirements of this chapter. *Occupants* of a *dwelling unit*, *rooming unit* or *housekeeping unit* are responsible for keeping in a clean, sanitary and safe condition that part of the *dwelling unit*, *rooming unit*, *housekeeping unit* or *premises* they occupy and control.

#### **301.3 Vacant structures and land.**

Vacant structures and *premises* thereof or vacant land shall be maintained in a clean, safe, secure and sanitary condition as provided herein so as not to cause a blighting problem or adversely affect the public health or safety. The level at which they are maintained shall not be lower than the average standards of maintenance generally used by owners of occupied structures and land throughout this city.

### SECTION 302 EXTERIOR PROPERTY AREAS

#### **302.1 Sanitation.**

*Exterior property* and *premises* shall be maintained in a clean, safe and sanitary condition. The *occupant* shall keep that part of the *exterior property* that such *occupant* occupies or controls in a clean and sanitary condition.

#### **302.2 Grading and drainage.**

*Premises* shall be graded and maintained to prevent the erosion of soil and to prevent the accumulation of stagnant water thereon, or within any *structure* located thereon.

**Exception:** *Approved* retention areas and reservoirs.

### **302.3 Sidewalks and driveways.**

Sidewalks, walkways, stairs, driveways, parking spaces and similar areas shall be kept in a proper state of repair, and maintained free from hazardous conditions.

### **302.4 Weeds.**

*Premises* and *exterior property* shall be maintained free from weeds or plant growth in excess of eight inches. Noxious weeds shall be prohibited. Weeds shall be defined as all grasses, annual plants and vegetation, other than trees or shrubs provided; however, this term shall not include cultivated flowers and gardens, nor shall it include natural areas designated as such under Section 551.02, General Offenses Code.

Upon failure of the *owner* or agent having charge of a property to cut and destroy weeds after service of a notice of violation, they shall be subject to prosecution in accordance with Section 109.3 and as prescribed by the authority having jurisdiction. Upon failure to comply with the notice of violation, any duly authorized employee of the jurisdiction or contractor hired by the jurisdiction shall be authorized to enter upon the property in violation and cut and destroy the weeds growing thereon, and the costs of such removal shall be paid by the *owner* or agent responsible for the property.

### **302.5 Rodent harborage.**

Structures and *exterior property* shall be kept free from rodent harborage and *infestation*. Where rodents are found, they shall be promptly exterminated by *approved* processes that will not be injurious to human health. After *pest elimination*, proper precautions shall be taken to eliminate rodent harborage and prevent reinfestation.

### **302.6 Exhaust vents.**

Pipes, ducts, conductors, fans or blowers shall not discharge gases, steam, vapor, hot air, grease, smoke, odors or other gaseous or particulate wastes directly on abutting or adjacent public or private property or that of another *tenant*.

### **302.7 Accessory structures.**

Accessory structures, including *detached* garages, fences and walls, shall be maintained structurally sound and in good repair. All garages, including those attached to the principal structure, shall have operating overhead or horizontal doors to provide security for the property within and in the case of attached garages, for the occupants of the principal structure. (Ord. 4594, passed 10/10/05, effective 11/10/05).

### **302.8 Motor vehicles.**

No motor vehicle shall be stored, kept or parked outside on any property unless there is displayed or mounted upon it whatever license or registration tag is required by Ohio law to permit that vehicle to be lawfully operated on public streets. For the purpose of this section, the words "motor vehicle" shall have the same meaning as in the Uniform Traffic Laws of the State of Ohio. Except as provided for in other regulations, inoperative or unlicensed motor vehicles shall not be parked, kept or stored on any *premises*, and vehicles shall not at any time be in a state of major disassembly, disrepair, or in the process of being stripped or dismantled. Painting of vehicles is prohibited unless conducted inside an *approved* spray booth.

**Exception:** A vehicle of any type is permitted to undergo major overhaul, including body work, provided that such work is performed inside a *structure* or similarly enclosed area designed and *approved* for such purposes.



### **302.9 Defacement of property.**

A person shall not willfully or wantonly damage, mutilate or deface any exterior surface of any *structure* or building on any private or public property by placing thereon any marking, carving or graffiti.

It shall be the responsibility of the *owner* to restore said surface to an *approved* state of maintenance and repair.

### **302.10 General maintenance standards for exterior property areas.**

All exterior property and premises shall be maintained so as not to cause a blighting problem, not to adversely affect the public health or safety, not to adversely affect premises because that decreases property values and in turn lowers the quality of life in this city, but instead shall be maintained so as to have a positive impact on the premises. Further, such work shall be performed in a manner which is in keeping with the standards of maintenance generally used by owners and occupants throughout this city. Leaves must be raked and disposed of so as to avoid unreasonable accumulations. All poisonous weeds or plants shall be destroyed and removed. All land or dirt shall be maintained so as to be covered with vegetation ground cover, except areas covered by or used for:

- A. buildings or structures;
- B. other substances allowed under the Zoning Code;
- C. gardens or flowerbeds;
- D. construction of improvements;
- E. recreation or outdoor storage uses; or
- F. public area nature parks or private lot nature areas designated by the city under Section 551.02 of the General Offenses Code.

### **302.11 Obsolete signs.**

(DELETED - Regulated under Oakwood Zoning Code)

### **302.12 Owner responsible for unpaved right-of-way.**

For the purposes of this Code, the words "exterior property" and "premises" shall include the strip of land sometimes referred to as the tree lawn (i.e. the portion of right-of-way between the curb, or the paved street if there is no curb, and the sidewalk) and any other unpaved portion of right-of-way which abuts property of an owner. Accordingly, the owner shall be responsible for causing such unpaved right-of-way to comply with the maintenance requirements of this Code.

### **302.13 Screening or removal of outdoor storage.**

In the Neighborhood and Community business zoning districts, all storage of materials, goods or products shall be within enclosed buildings or shall be effectively screened from view in a manner subject to the approval of the Planning Commission of this city. Off-street parking of operative vehicles shall be an exception to this requirement.

In residential zoning districts, all outdoor storage for a period exceeding 15 continuous days (with any part of such a day being counted as an entire day) shall be enclosed or effectively screened from view in a manner subject to the approval of the Planning Commission. The storage of such functional items as children's play structures, firewood and operable automobiles and vehicles shall be exempt from this requirement.

If the principal building on any premises has become vacant, portable objects shall not be stored outside on that lot but instead shall be placed within an enclosed structure.

### **302.14 Diseased and dead trees.**

Diseased trees are those with any form of decay or vegetation sickness that can be transmitted to other trees, plus those infected with insects to such an extent as to create a nuisance adversely affecting nearby persons or property. Such trees shall be removed immediately or shall be treated or sprayed to eliminate at once the risk of the decay or vegetation sickness being transmitted to other trees and to remove the insect nuisance situation.

The code official shall determine if a dead tree constitutes a safety hazard because of its proximity to the right-of-way, any building or structure, or to persons who use nearby premises. If the code official decides that a tree constitutes such a safety hazard, it shall be removed at the expense of the owner or operator responsible for maintenance of the premises on which it is located.

### **302.15 Casualty damage repair.**

Within 30 days after casualty damage to any structure or exterior premises, the owner shall have taken the following steps:

- A. contracted for repair and restoration of damaged areas and removal of debris; and/or
- B. contracted for the demolition (as regulated by the Building Code of this city) and removal of any portions of the premises not to be repaired and restored, and also for removal of debris in connection therewith; and
- C. arranged for the contract work to be completed within 60 days from the contract date, except to the extent a delay is caused by weather, strikes, acts of God or other matters beyond the reasonable control of the owner and contractor.

The code official may extend these time periods to the extent he or she deems appropriate, but shall not be required to do so. Time is of the essence in repairing damage quickly so as to avoid detrimental impact upon persons and property.

## **SECTION 303 SWIMMING POOLS, SPAS AND HOT TUBS**

### **303.1 Swimming pools.**

Swimming pools shall be maintained in a clean and sanitary condition, and in good repair.

### **303.2 Enclosures.**

Private swimming pools, hot tubs and spas, containing water more than 24 inches (610 mm) in depth shall be completely surrounded by a fence or barrier not less than 48 inches (1219 mm) in height above the finished ground level measured on the side of the barrier away from the pool. Gates and doors in such barriers shall be self-closing and self-latching. Where the self-latching device is less than 54 inches (1372 mm) above the bottom of the gate, the release mechanism shall be located on the pool side of the gate. Self-closing and self-latching gates shall be maintained such that the gate will positively close and latch when released from an open position of 6 inches (152 mm) from the gatepost. An existing pool enclosure shall not be removed, replaced or changed in a manner that reduces its effectiveness as a safety barrier.

**Exception:** Spas or hot tubs with a safety cover that complies with ASTM F1346 shall be exempt from the provisions of this section.

## SECTION 304 EXTERIOR STRUCTURE

### 304.1 General.

The exterior of a *structure* shall be maintained in good repair, structurally sound and sanitary so as not to pose a threat to the public health, safety or welfare. As additional standards of maintenance, the exterior of every structure shall be maintained in high quality, first-class condition so as not to have a negative effect upon the value of the subject property, or upon the value of other property in the neighborhood or the city, not to cause a blighting problem or adversely affect the public health or safety, and in accordance with the standards of maintenance generally used by owners and occupants throughout this city.

#### 304.1.1 Unsafe conditions.

The following conditions shall be determined as unsafe and shall be repaired or replaced to comply with the *International Building Code* or the *International Existing Building Code* as required for existing buildings:

1. The nominal strength of any structural member is exceeded by nominal loads, the load effects or the required strength.
2. The *anchorage* of the floor or roof to walls or columns, and of walls and columns to foundations is not capable of resisting all nominal loads or load effects.
3. Structures or components thereof that have reached their limit state.
4. Siding and masonry joints including joints between the building envelope and the perimeter of windows, doors and skylights are not maintained, weather resistant or water tight.
5. Structural members that have evidence of *deterioration* or that are not capable of safely supporting all nominal loads and load effects.
6. Foundation systems that are not firmly supported by footings, are not plumb and free from open cracks and breaks, are not properly *anchored* or are not capable of supporting all nominal loads and resisting all load effects.
7. Exterior walls that are not *anchored* to supporting and supported elements or are not plumb and free of holes, cracks or breaks and loose or rotting materials, are not properly *anchored* or are not capable of supporting all nominal loads and resisting all load effects.
8. Roofing or roofing components that have defects that admit rain, roof surfaces with inadequate drainage, or any portion of the roof framing that is not in good repair with signs of *deterioration*, fatigue or without proper anchorage and incapable of supporting all nominal loads and resisting all load effects.
9. Flooring and flooring components with defects that affect serviceability or flooring components that show signs of *deterioration* or fatigue, are not properly *anchored* or are incapable of supporting all nominal loads and resisting all load effects.
10. Veneer, cornices, belt courses, corbels, trim, wall facings and similar decorative features not properly *anchored* or that are *anchored* with connections not capable of supporting all nominal loads and resisting all load effects.

11. Overhang extensions or projections including, but not limited to, trash chutes, canopies, marquees, signs, awnings, fire escapes, standpipes and exhaust ducts not properly *anchored* or that are *anchored* with connections not capable of supporting all nominal loads and resisting all load effects.
12. Exterior stairs, decks, porches, balconies and all similar appurtenances attached thereto, including *guards* and handrails, are not structurally sound, not properly *anchored* or that are *anchored* with connections not capable of supporting all nominal loads and resisting all load effects.
13. Chimneys, cooling towers, smokestacks and similar appurtenances not structurally sound or not properly *anchored*, or that are *anchored* with connections not capable of supporting all nominal loads and resisting all load effects.

**Exceptions:**

1. Where substantiated otherwise by an *approved* method.
2. Demolition of unsafe conditions shall be permitted where *approved* by the *code official*.

**304.2 Protective treatment.**

Exterior surfaces, including but not limited to, doors, door and window frames, cornices, porches, trim, balconies, decks and fences, shall be maintained in good condition. Exterior wood surfaces, other than decay-resistant woods, shall be protected from the elements and decay by painting or other protective covering or treatment. Peeling, flaking and chipped paint shall be eliminated and surfaces repainted. Siding and masonry joints, as well as those between the building envelope and the perimeter of windows, doors and skylights, shall be maintained weather resistant and water tight. Metal surfaces subject to rust or corrosion shall be coated to inhibit such rust and corrosion, and surfaces with rust or corrosion shall be stabilized and coated to inhibit future rust and corrosion. Oxidation stains shall be removed from exterior surfaces. Surfaces designed for stabilization by oxidation are exempt from this requirement.

**[F] 304.3 Premises identification.**

Buildings shall have *approved* address numbers placed in a position to be plainly legible and visible from the street or road fronting the property. These numbers shall contrast with their background. Address numbers shall be Arabic numerals or alphabet letters. Numbers shall be not less than 4 inches (102 mm) in height with a minimum stroke width of 0.5 inch (12.7 mm).

**304.4 Structural members.**

Structural members shall be maintained free from *deterioration*, and shall be capable of safely supporting the imposed dead and live loads.

**304.5 Foundation walls.**

Foundation walls shall be maintained plumb and free from open cracks and breaks and shall be kept in such condition so as to prevent the entry of rodents and other pests.

**304.6 Exterior walls.**

Exterior walls shall be free from holes, breaks, and loose or rotting materials; and maintained weatherproof and properly surface coated where required to prevent *deterioration*.

### **304.7 Roofs and drainage.**

The roof and flashing shall be sound, tight and not have defects that admit rain. Roof drainage shall be adequate to prevent dampness or *deterioration* in the walls or interior portion of the *structure*. Roof drains, gutters and downspouts shall be maintained in good repair and free from obstructions. Roof water shall not be discharged in a manner that creates a public nuisance.

### **304.8 Decorative features.**

Cornices, belt courses, corbels, terra cotta trim, wall facings and similar decorative features shall be maintained in good repair with proper *anchorage* and in a safe condition.

### **304.9 Overhang extensions.**

Overhang extensions including, but not limited to, canopies, marquees, signs, metal awnings, fire escapes, standpipes and exhaust ducts shall be maintained in good repair and be properly *anchored* so as to be kept in a sound condition. Where required, all exposed surfaces of metal or wood shall be protected from the elements and against decay or rust by periodic application of weather-coating materials, such as paint or similar surface treatment.

### **304.10 Stairways, decks, porches and balconies.**

Every exterior stairway, deck, porch and balcony, and all appurtenances attached thereto, shall be maintained structurally sound, in good repair, with proper *anchorage* and capable of supporting the imposed loads.

### **304.11 Chimneys and towers.**

Chimneys, cooling towers, smoke stacks, and similar appurtenances shall be maintained structurally safe and sound, and in good repair. Exposed surfaces of metal or wood shall be protected from the elements and against decay or rust by periodic application of weather-coating materials, such as paint or similar surface treatment.

### **304.12 Handrails and guards.**

Every handrail and *guard* shall be firmly fastened and capable of supporting normally imposed loads and shall be maintained in good condition.

### **304.13 Window, skylight and door frames.**

Every window, skylight, door and frame shall be kept in sound condition, good repair and weather tight.

#### **304.13.1 Glazing.**

Glazing materials shall be maintained free from cracks and holes.

#### **304.13.2 Openable windows.**

Every window, other than a fixed window, shall be easily openable and capable of being held in position by window hardware.

### **304.14 Insect screens.**

During the period from **May 1** to October 31 of each year, inclusive, every door, window and other outside opening required for *ventilation* of habitable rooms, food preparation areas, food service areas or any areas where products to be included or utilized in food for human consumption are processed, manufactured, packaged or stored shall be supplied with *approved* tightly fitting screens of minimum 16 mesh per inch (16 mesh per 25 mm), and every screen door used for insect control shall have a self-closing device in good working condition.

**Exception:** Screens shall not be required where other *approved* means, such as air curtains or insect repellent fans, are employed.

**304.15 Doors.**

Exterior doors, door assemblies, operator systems if provided, and hardware shall be maintained in good condition. Locks at all entrances to *dwelling units* and sleeping units shall tightly secure the door. Locks on means of egress doors shall be in accordance with Section 702.3.

**304.16 Basement hatchways.**

Every *basement* hatchway shall be maintained to prevent the entrance of rodents, rain and surface drainage water.

**304.17 Guards for basement windows.**

Every *basement* window that is openable shall be supplied with rodent shields, storm windows or other *approved* protection against the entry of rodents.

**304.18 Building security.**

Doors, windows or hatchways for *dwelling units*, room units or *housekeeping units* shall be provided with devices designed to provide security for the *occupants* and property within.

**304.18.1 Doors.**

Doors providing access to a *dwelling unit*, *rooming unit* or *housekeeping unit* that is rented, leased or let shall be equipped with a deadbolt lock designed to be readily openable from the side from which egress is to be made without the need for keys, special knowledge or effort and shall have a minimum lock throw of 1 inch (25 mm). Such deadbolt locks shall be installed according to the manufacturer's specifications and maintained in good working order. For the purpose of this section, a sliding bolt shall not be considered an acceptable deadbolt lock.

**304.18.2 Windows.**

Operable windows located in whole or in part within 6 feet (1828 mm) above ground level or a walking surface below that provide access to a *dwelling unit*, *rooming unit* or *housekeeping unit* that is rented, leased or let shall be equipped with a window sash locking device.

**304.18.3 Basement hatchways.**

*Basement* hatchways that provide access to a *dwelling unit*, *rooming unit* or *housekeeping unit* that is rented, leased or let shall be equipped with devices that secure the units from unauthorized entry.

**304.19 Gates.**

Exterior gates, gate assemblies, operator systems if provided, and hardware shall be maintained in good condition. Latches at all entrances shall tightly secure the gates.

**SECTION 305  
INTERIOR STRUCTURE**

**305.1 General.**

The interior of a *structure* and equipment therein shall be maintained in good repair, structurally sound and in a sanitary condition. *Occupants* shall keep that part of the *structure* that they occupy or control in a clean and sanitary condition. Every *owner* of a *structure* containing a *rooming house*, *housekeeping units*, a hotel, a dormitory, two or more *dwelling units* or two or more nonresidential *occupancies*, shall

maintain, in a clean and sanitary condition, the shared or public areas of the *structure* and *exterior property*.

#### **305.1.1 Unsafe conditions.**

The following conditions shall be determined as unsafe and shall be repaired or replaced to comply with the *International Building Code* or the *International Existing Building Code* as required for existing buildings:

1. The nominal strength of any structural member is exceeded by nominal loads, the load effects or the required strength.
2. The anchorage of the floor or roof to walls or columns, and of walls and columns to foundations is not capable of resisting all nominal loads or load effects.
3. Structures or components thereof that have reached their limit state.
4. Structural members are incapable of supporting nominal loads and load effects.
5. Stairs, landings, balconies and all similar walking surfaces, including *guards* and handrails, are not structurally sound, not properly *anchored* or are *anchored* with connections not capable of supporting all nominal loads and resisting all load effects.
6. Foundation systems that are not firmly supported by footings are not plumb and free from open cracks and breaks, are not properly *anchored* or are not capable of supporting all nominal loads and resisting all load effects.

#### **Exceptions:**

1. Where substantiated otherwise by an *approved* method.
2. Demolition of unsafe conditions shall be permitted where *approved* by the *code official*.

#### **305.2 Structural members.**

Structural members shall be maintained structurally sound, and be capable of supporting the imposed loads.

#### **305.3 Interior surfaces.**

Interior surfaces, including windows and doors, shall be maintained in good, clean and sanitary condition. Peeling, chipping, flaking or abraded paint shall be repaired, removed or covered. Cracked or loose plaster, decayed wood and other defective surface conditions shall be corrected.

#### **305.4 Stairs and walking surfaces.**

Every stair, ramp, landing, balcony, porch, deck or other walking surface shall be maintained in sound condition and good repair.

#### **305.5 Handrails and guards.**

Every handrail and *guard* shall be firmly fastened and capable of supporting normally imposed loads and shall be maintained in good condition.

### **305.6 Interior doors.**

Every interior door shall fit reasonably well within its frame and shall be capable of being opened and closed by being properly and securely attached to jambs, headers or tracks as intended by the manufacturer of the attachment hardware.

## **SECTION 306 COMPONENT SERVICEABILITY**

### **306.1 General.**

The components of a *structure* and equipment therein shall be maintained in good repair, structurally sound and in a sanitary condition. These requirements shall apply to interior but not to exterior stairways, landings and balconies unless they are more than (ten feet) 10' higher than the grade below. The code official may grant an administrative variance from this exterior requirement, on his own motion or on request of the property owner, so as to increase the ten feet (10') height by up to 20%, if the facts are such that the code official makes the same written conclusions of fact that are required by Section 107.2(D) for variances.

#### **306.1.1 Unsafe conditions.**

Where any of the following conditions cause the component or system to be beyond its limit state, the component or system shall be determined as unsafe and shall be repaired or replaced to comply with the *International Building Code* or the *International Existing Building Code* as required for existing buildings:

1. Soils that have been subjected to any of the following conditions:
  - 1.1. Collapse of footing or foundation system.
  - 1.2. Damage to footing, foundation, concrete or other structural element due to soil expansion.
  - 1.3. Adverse effects to the design strength of footing, foundation, concrete or other structural element due to a chemical reaction from the soil.
  - 1.4. Inadequate soil as determined by a geotechnical investigation.
  - 1.5. Where the allowable bearing capacity of the soil is in doubt.
  - 1.6. Adverse effects to the footing, foundation, concrete or other structural element due to the ground water table.
2. Concrete that has been subjected to any of the following conditions:
  - 2.1. *Deterioration.*
  - 2.2. *Ultimate deformation.*
  - 2.3. Fractures.
  - 2.4. Fissures.
  - 2.5. Spalling.



- 2.6. Exposed reinforcement.
- 2.7. *Detached*, dislodged or failing connections.
3. Aluminum that has been subjected to any of the following conditions:
  - 3.1. *Deterioration*.
  - 3.2. Corrosion.
  - 3.3. Elastic deformation.
  - 3.4. *Ultimate deformation*.
  - 3.5. Stress or strain cracks.
  - 3.6. Joint fatigue.
  - 3.7. *Detached*, dislodged or failing connections.
4. Masonry that has been subjected to any of the following conditions:
  - 4.1. *Deterioration*.
  - 4.2. *Ultimate deformation*.
  - 4.3. Fractures in masonry or mortar joints.
  - 4.4. Fissures in masonry or mortar joints.
  - 4.5. Spalling.
  - 4.6. Exposed reinforcement.
  - 4.7. *Detached*, dislodged or failing connections.
5. Steel that has been subjected to any of the following conditions:
  - 5.1. *Deterioration*.
  - 5.2. Elastic deformation.
  - 5.3. *Ultimate deformation*.
  - 5.4. Metal fatigue.
  - 5.5. *Detached*, dislodged or failing connections.
6. Wood that has been subjected to any of the following conditions:

- 6.1. Ultimate deformation.
- 6.2. Deterioration.
- 6.3. Damage from insects, rodents and other vermin.
- 6.4. Fire damage beyond charring.
- 6.5. Significant splits and checks.
- 6.6. Horizontal shear cracks.
- 6.7. Vertical shear cracks.
- 6.8. Inadequate support.
- 6.9. *Detached*, dislodged or failing connections.
- 6.10. Excessive cutting and notching.

**Exceptions:**

1. Where substantiated otherwise by an *approved* method.
2. Demolition of unsafe conditions shall be permitted where *approved* by the *code official*.

## **SECTION 307 HANDRAILS AND GUARDRAILS**

### **307.1 General.**

Every exterior and interior flight of stairs having more than four risers shall have a handrail on one side of the stair and every open portion of a stair, landing, balcony, porch, deck, ramp or other walking surface that is more than 30 inches (762 mm) above the floor or grade below shall have *guards*. Handrails shall be not less than 30 inches (762 mm) in height or more than 42 inches (1067 mm) in height measured vertically above the nosing of the tread or above the finished floor of the landing or walking surfaces. *Guards* shall be not less than 30 inches (762 mm) in height above the floor of the landing, balcony, porch, deck, or ramp or other walking surface.

**Exception:** *Guards* shall not be required where exempted by the adopted building code.

## **SECTION 308 RUBBISH AND GARBAGE**

### **308.1 Accumulation of rubbish or garbage.**

*Exterior property* and *premises*, and the interior of every *structure*, shall be free from any accumulation of *rubbish* or garbage. The interior of every structure shall be free from any undue accumulation of rubbish or garbage so as to avoid detrimental effects on physical or mental health of occupants or users of the premises and to avoid significant adverse impact upon the value of the property since that would, in turn,

negatively impact on neighboring properties and the quality of life throughout not only the neighborhood but the City of Oakwood.

### **308.2 Disposal of rubbish.**

Every *occupant* of a *structure* shall dispose of all *rubbish* in a clean and sanitary manner by placing such *rubbish* in *approved* containers.

#### **308.2.1 Rubbish storage facilities.**

The *owner* of every occupied *premises* shall supply *approved* covered containers for *rubbish*, and the *owner* of the *premises* shall be responsible for the removal of *rubbish*.

#### **308.2.2 Refrigerators.**

Refrigerators and similar equipment not in operation shall not be discarded, abandoned or stored on *premises* without first removing the doors.

### **308.3 Disposal of garbage.**

Every *occupant* of a *structure* shall dispose of garbage in a clean and sanitary manner by placing such garbage in an *approved* garbage disposal facility or *approved* garbage containers.

#### **308.3.1 Garbage facilities.**

The *owner* of every dwelling shall supply one of the following: an *approved* mechanical food waste grinder in each *dwelling unit*; an *approved* incinerator unit in the *structure* available to the *occupants* in each *dwelling unit*; or an *approved* leakproof, covered, outside garbage container.

#### **308.3.2 Containers.**

The *operator* of every establishment producing garbage shall provide, and at all times cause to be utilized, *approved* leakproof containers provided with close-fitting covers for the storage of such materials until removed from the *premises* for disposal.

## **SECTION 309 PEST ELIMINATION**

### **309.1 Infestation.**

All structures shall be kept free from undue insect, rat and rodent infestation, so as to avoid detrimental effects on physical or mental health of occupants or users of the premises and to avoid significant adverse impact upon the value of the property since that would, in turn, negatively impact on neighboring properties and the quality of life throughout not only the neighborhood but the City of Oakwood. All structures in which such accumulations of insects, rats or rodents are found shall be promptly exterminated by procedures accepted within the extermination industry and customarily used in Montgomery County, Ohio, and not contrary to other ordinances of the city or to rules, regulations or orders issued by or for the Oakwood Health District. After *pest elimination*, proper precautions shall be taken to prevent reinfestation.

### **309.2 Owner.**

The *owner* of any *structure* shall be responsible for *pest elimination* within the *structure* prior to renting or leasing the *structure*.

### **309.3 Single occupant.**

The *occupant* of a one-family dwelling or of a single-*tenant* nonresidential *structure* shall be responsible for *pest elimination* on the *premises*.

**309.4 Multiple occupancy.**

The *owner* of a *structure* containing two or more *dwelling units*, a multiple *occupancy*, a *rooming house* or a nonresidential *structure* shall be responsible for *pest elimination* in the public or shared areas of the *structure* and *exterior property*. If *infestation* is caused by failure of an *occupant* to prevent such *infestation* in the area occupied, the *occupant* and *owner* shall be responsible for *pest elimination*.

**309.5 Occupant.**

The *occupant* of any *structure* shall be responsible for the continued rodent and pest-free condition of the *structure*.

**Exception:** Where the *infestations* are caused by defects in the *structure*, the *owner* shall be responsible for *pest elimination*.

## CHAPTER 4 LIGHT, VENTILATION AND OCCUPANCY LIMITATIONS

---

### User note:

*About this chapter:* Chapter 4 sets forth requirements to establish the minimum environment for occupiable and habitable buildings by establishing the minimum criteria for light and ventilation and identifying occupancy limitations including minimum room width and area, minimum ceiling height and restrictions to prevent overcrowding.

---

### SECTION 401 GENERAL

#### 401.1 Scope.

The provisions of this chapter shall govern the minimum conditions and standards for light, *ventilation* and space for occupying a *structure*.

#### 401.2 Responsibility.

The *owner* of the *structure* shall provide and maintain light, *ventilation* and space conditions in compliance with these requirements. A person shall not occupy as *owner-occupant*, or permit another person to occupy, any *premises* that do not comply with the requirements of this chapter.

#### 401.3 Alternative devices.

In lieu of the means for natural light and *ventilation* herein prescribed, artificial light or mechanical *ventilation* complying with the applicable building code shall be permitted.

### SECTION 402 LIGHT

#### 402.1 Habitable spaces.

Every *habitable space* shall have not less than one window of *approved* size facing directly to the outdoors or to a court. The minimum total glazed area for every *habitable space* shall be 8 percent of the floor area of such room. Wherever walls or other portions of a *structure* face a window of any room and such obstructions are located less than 3 feet (914 mm) from the window and extend to a level above that of the ceiling of the room, such window shall not be deemed to face directly to the outdoors nor to a court and shall not be included as contributing to the required minimum total window area for the room.

**Exception:** Where natural light for rooms or spaces without exterior glazing areas is provided through an adjoining room, the unobstructed opening to the adjoining room shall be not less than 8 percent of

the floor area of the interior room or space, or not less than 25 square feet (2.33 m<sup>2</sup>), whichever is greater. The exterior glazing area shall be based on the total floor area being served.

#### 402.2 Common halls and stairways.

Every common hall and stairway in residential *occupancies*, other than in one- and two-family dwellings, shall be lighted at all times with not less than a 60-watt standard incandescent light bulb for each 200 square feet (19 m<sup>2</sup>) of floor area or equivalent illumination, provided that the spacing between lights shall not be greater than 30 feet (9144 mm). In other than residential occupancies, interior and exterior means

of egress, stairways shall be illuminated at all times the building space served by the means of egress is occupied with not less than 1 footcandle (11 lux) at floors, landings and treads.

#### **402.3 Other spaces.**

Other spaces shall be provided with natural or artificial light sufficient to permit the maintenance of sanitary conditions, and the safe *occupancy* of the space and utilization of the appliances, equipment and fixtures.

### **SECTION 403 VENTILATION**

#### **403.1 Habitable spaces.**

Every *habitable space* shall have not less than one openable window. The total openable area of the window in every room shall be equal to not less than 45 percent of the minimum glazed area required in Section 402.1.

**Exception:** Where rooms and spaces without openings to the outdoors are ventilated through an adjoining room, the unobstructed opening to the adjoining room shall be not less than 8 percent of the floor area of the interior room or space, but not less than 25 square feet (2.33 m<sup>2</sup>). The *ventilation* openings to the outdoors shall be based on a total floor area being ventilated.

#### **403.2 Bathrooms and toilet rooms.**

Every *bathroom* and *toilet room* shall comply with the *ventilation* requirements for *habitable spaces* as required by Section 403.1, except that a window shall not be required in such spaces equipped with a mechanical *ventilation* system. Air exhausted by a mechanical *ventilation* system from a *bathroom* or *toilet room* shall discharge to the outdoors and shall not be recirculated.

#### **403.3 Cooking facilities.**

Unless *approved* through the certificate of *occupancy*, cooking shall not be permitted in any *rooming unit* or dormitory unit, and a cooking facility or appliance shall not be permitted to be present in the *rooming unit* or dormitory unit.

##### **Exceptions:**

1. Where specifically *approved* in writing by the *code official*.
2. Devices such as coffee pots and microwave ovens shall not be considered cooking appliances.

#### **403.4 Process ventilation.**

Where injurious, toxic, irritating or noxious fumes, gases, dusts or mists are generated, a local exhaust *ventilation* system shall be provided to remove the contaminating agent at the source. Air shall be exhausted to the exterior and not be recirculated to any space.

#### **403.5 Clothes dryer exhaust.**

Clothes dryer exhaust systems shall be independent of all other systems and shall be exhausted outside the *structure* in accordance with the manufacturer's instructions.

**Exception:** Listed and *labeled* condensing (ductless) clothes dryers.

## SECTION 404 OCCUPANCY LIMITATIONS

### 404.1 Privacy.

*Dwelling units*, hotel units, *housekeeping units*, *rooming units* and dormitory units shall be arranged to provide privacy and be separate from other adjoining spaces.

### 404.2 Minimum room widths.

A habitable room, other than a kitchen, shall be not less than 7 feet (2134 mm) in any plan dimension. Kitchens shall have a minimum clear passageway of 3 feet (914 mm) between counterfronts and appliances or counterfronts and walls.

### 404.3 Minimum ceiling heights.

*Habitable spaces*, hallways, corridors, laundry areas, *bathrooms*, *toilet rooms* and habitable *basement* areas shall have a minimum clear ceiling height of 7 feet (2134 mm).

#### Exceptions:

1. In one- and two-family dwellings, beams or girders spaced not less than 4 feet (1219 mm) on center and projecting not greater than 6 inches (152 mm) below the required ceiling height.
2. *Basement* rooms in one- and two-family dwellings occupied exclusively for laundry, study or recreation purposes, having a minimum ceiling height of 6 feet 8 inches (2033 mm) with a minimum clear height of 6 feet 4 inches (1932 mm) under beams, girders, ducts and similar obstructions.
3. Rooms occupied exclusively for sleeping, study or similar purposes and having a sloped ceiling over all or part of the room, with a minimum clear ceiling height of 7 feet (2134 mm) over not less than one-third of the required minimum floor area. In calculating the floor area of such rooms, only those portions of the floor area with a minimum clear ceiling height of 5 feet (1524 mm) shall be included.

### 404.4 Bedroom and living room requirements.

Every *bedroom* and living room shall comply with the requirements of Sections 404.4.1 through 404.4.5.

#### 404.4.1 Room area.

Every living room shall contain not less than 120 square feet (11.2 m<sup>2</sup>) and every bedroom shall contain not less than 80 square feet (6.5 m<sup>2</sup>) and every bedroom occupied by more than one person shall contain not less than 60 square feet (4.6 m<sup>2</sup>) of floor area for each *occupant* thereof.

#### 404.4.2 Access from bedrooms.

*Bedrooms* shall not constitute the only means of access to other *bedrooms* or *habitable spaces* and shall not serve as the only means of egress from other *habitable spaces*.

**Exception:** Units that contain fewer than two *bedrooms*.

#### 404.4.3 Water closet accessibility.

Every *bedroom* shall have access to not less than one water closet and one lavatory without passing

through another *bedroom*. Every *bedroom* in a *dwelling unit* shall have access to not less than one water closet and lavatory located in the same story as the *bedroom* or an adjacent story.

**404.4.4 Prohibited occupancy.**

Kitchens and nonhabitable spaces shall not be used for sleeping purposes.

**404.4.5 Other requirements.**

*Bedrooms* shall comply with the applicable provisions of this code including, but not limited to, the light, *ventilation*, room area, ceiling height and room width requirements of this chapter; the plumbing facilities and water-heating facilities requirements of Chapter 5; the heating facilities and electrical receptacle requirements of Chapter 6; and the smoke detector and emergency escape requirements of Chapter 7.

**404.5 Overcrowding.**

*Dwelling units* shall not be occupied by more *occupants* than permitted by the minimum area requirements of Table 404.5. Further, every dwelling unit shall contain at least 150 square feet of floor space for the first occupant, at least 150 additional square feet of floor space for the second occupant, and at least 100 additional square feet of floor space for each additional occupant.

**TABLE 404.5  
MINIMUM AREA REQUIREMENTS**

SPACE	MINIMUM AREA IN SQUARE FEET		
	1-2 occupants	3-5 occupants	6 or more occupants
Living room <sup>a, b</sup>	120	120	150
Dining room <sup>a, b</sup>	No requirement	80	100
Bedrooms	Shall comply with Section 404.4.1		

For SI: 1 square foot = 0.0929 m<sup>2</sup>.

- a. See Section 404.5.2 for combined living room/dining room spaces.
- b. See Section 404.5.1 for limitations on determining the minimum occupancy area for sleeping purposes.

**404.5.1 Sleeping area.**

The minimum occupancy area required by Table 404.5 shall not be included as a sleeping area in determining the minimum occupancy area for sleeping purposes. Sleeping areas shall comply with Section 404.4.

**404.5.2 Combined spaces.**

Combined living room and dining room spaces shall comply with the requirements of Table 404.5 if the total area is equal to that required for separate rooms and if the space is located so as to function as a combination living room/dining room.

**404.6 Efficiency unit.**

Nothing in this section shall prohibit an efficiency living unit from meeting the following requirements:



1. A unit occupied by not more than one *occupant* shall have a minimum clear floor area of 120 square feet (11.2 m<sup>2</sup>). A unit occupied by not more than two *occupants* shall have a minimum clear floor area of 220 square feet (20.4 m<sup>2</sup>). A unit occupied by three *occupants* shall have a minimum clear floor area of 320 square feet (29.7 m<sup>2</sup>). These required areas shall be exclusive of the areas required by Items 2 and 3.
2. The unit shall be provided with a kitchen sink, cooking appliance and refrigeration facilities, each having a minimum clear working space of 30 inches (762 mm) in front. Light and *ventilation* conforming to this code shall be provided.
3. The unit shall be provided with a separate *bathroom* containing a water closet, lavatory and bathtub or shower.
4. The maximum number of *occupants* shall be three.

**404.7 Food preparation.**

Spaces to be occupied for food preparation purposes shall contain suitable space and equipment to store, prepare and serve foods in a sanitary manner. There shall be adequate facilities and services for the sanitary disposal of food wastes and refuse, including facilities for temporary storage.

## CHAPTER 5 PLUMBING FACILITIES AND FIXTURE REQUIREMENTS

---

### User note:

*About this chapter:* Chapter 5 establishes minimum sanitary and clean conditions in occupied buildings by containing requirements for the installation, maintenance and location of plumbing systems and facilities, including the water supply system, water heating appliances, sewage disposal systems and related plumbing fixtures. Chapter 5 includes requirements for providing potable water to a building and the basic fixtures to effectively utilize and dispose of that water.

---

### SECTION 501 GENERAL

#### 501.1 Scope.

The provisions of this chapter shall govern the minimum plumbing systems, facilities and plumbing fixtures to be provided.

#### 501.2 Responsibility.

The *owner* of the *structure* shall provide and maintain such plumbing facilities and plumbing fixtures in compliance with these requirements. A person shall not occupy as *owner-occupant* or permit another person to occupy any *structure* or *premises* that does not comply with the requirements of this chapter.

### SECTION 502 REQUIRED FACILITIES

#### [P] 502.1 Dwelling units.

Every *dwelling unit* shall contain its own bathtub or shower, lavatory, water closet and kitchen sink that shall be maintained in a sanitary, safe working condition. The lavatory shall be placed in the same room as the water closet or located in close proximity to the door leading directly into the room in which such water closet is located. A kitchen sink shall not be used as a substitute for the required lavatory.

#### [P] 502.2 Rooming houses.

Not less than one water closet, lavatory and bathtub or shower shall be supplied for each four *rooming units*.

#### [P] 502.3 Hotels.

Where private water closets, lavatories and baths are not provided, one water closet, one lavatory and one bathtub or shower having access from a public hallway shall be provided for each 10 *occupants*.

#### [P] 502.4 Employees' facilities.

For fixed business locations, not less than one water closet, one lavatory and one drinking facility shall be available to employees.

##### [P] 502.4.1 Drinking facilities.

Drinking facilities shall be a drinking fountain, water cooler, bottled water cooler, or area for the storage and filling of employee water bottles or disposable cups next to a sink or water dispenser. Drinking facilities shall not be located in *toilet rooms* or *bathrooms*.

**[P] 502.5 Public toilet facilities.**

Public toilet facilities shall be maintained in a safe, sanitary and working condition in accordance with the *International Plumbing Code*. Except for periodic maintenance or cleaning, public access and use shall be provided to the toilet facilities at all times during *occupancy* of the *premises*.

**SECTION 503  
TOILET ROOMS**

**[P] 503.1 Privacy.**

*Toilet rooms* and *bathrooms* shall provide privacy and shall not constitute the only passageway to a hall or other space, or to the exterior. A door and interior locking device shall be provided for all common or shared *bathrooms* and *toilet rooms* in a multiple dwelling.

**[P] 503.2 Location.**

*Toilet rooms* and *bathrooms* serving hotel units, *rooming units* or dormitory units or *housekeeping units*, shall have access by traversing not more than one flight of stairs and shall have access from a common hall or passageway.

**[P] 503.3 Location of employee toilet facilities.**

Toilet facilities shall have access from within the employees' working area. The required toilet facilities shall be located not more than one story above or below the employees' working area and the path of travel to such facilities shall not exceed a distance of 500 feet (152 m). Employee facilities shall either be separate facilities or combined employee and public facilities.

**Exception:** Facilities that are required for employees in storage structures or kiosks, which are located in adjacent structures under the same ownership, lease or control, shall not exceed a travel distance of 500 feet (152 m) from the employees' regular working area to the facilities.

**[P] 503.4 Floor surface.**

In other than *dwelling units*, every *toilet room* floor shall be maintained to be a smooth, hard, nonabsorbent surface to permit such floor to be easily kept in a clean and sanitary condition.

**SECTION 504  
PLUMBING SYSTEMS AND FIXTURES**

**[P] 504.1 General.**

Plumbing fixtures shall be properly installed and maintained in working order, and shall be kept free from obstructions, leaks and defects and be capable of performing the function for which such plumbing fixtures are designed. Plumbing fixtures shall be maintained in a safe, sanitary and functional condition.

**[P] 504.2 Fixture clearances.**

Plumbing fixtures shall have adequate clearances for usage and cleaning.

**[P] 504.3 Plumbing system hazards.**

Where it is found that a plumbing system in a *structure* constitutes a hazard to the *occupants* or the *structure* by reason of inadequate service, inadequate venting, cross connection, backsiphonage, improper installation, *deterioration* or damage or for similar reasons, the *code official* shall require the defects to be corrected to eliminate the hazard.

## SECTION 505 WATER SYSTEM

### **505.1 General.**

Every sink, lavatory, bathtub or shower, drinking fountain, water closet or other plumbing fixture shall be properly connected to either a public water system or to an *approved* private water system. Kitchen sinks, lavatories, laundry facilities, bathtubs and showers shall be supplied with hot or tempered and cold running water in accordance with the *International Plumbing Code*.

### **[P] 505.2 Contamination.**

The water supply shall be maintained free from contamination, and all water inlets for plumbing fixtures shall be located above the flood-level rim of the fixture. Shampoo basin faucets, janitor sink faucets and other hose bibs or faucets to which hoses are attached and left in place, shall be protected by an *approved* atmospheric-type vacuum breaker or an *approved* permanently attached hose connection vacuum breaker.

### **[P] 505.3 Supply.**

The water supply system shall be installed and maintained to provide a supply of water to plumbing fixtures, devices and appurtenances in sufficient volume and at pressures adequate to enable the fixtures to function properly, safely, and free from defects and leaks.

### **[P] 505.4 Water heating facilities.**

Water heating facilities shall be properly installed, maintained and capable of providing an adequate amount of water to be drawn at every required sink, lavatory, bathtub, shower and laundry facility at a temperature not less than 110°F (43°C). A gas-burning water heater shall not be located in any *bathroom, toilet room, bedroom* or other occupied room normally kept closed, unless adequate combustion air is provided. An *approved* combination temperature and pressure-relief valve and relief valve discharge pipe shall be properly installed and maintained on water heaters.

### **[P] 505.5 Nonpotable water reuse systems.**

Nonpotable water reuse systems and rainwater collection and conveyance systems shall be maintained in a safe and sanitary condition. Where such systems are not properly maintained, the systems shall be repaired to provide for safe and sanitary conditions, or the system shall be abandoned in accordance with Section 505.5.1.

#### **[P] 505.5.1 Abandonment of systems.**

Where a nonpotable water reuse system or a rainwater collection and distribution system is not maintained or the *owner* ceases use of the system, the system shall be abandoned in accordance with Section 1301.10 of the *International Plumbing Code*.

## SECTION 506 SANITARY DRAINAGE SYSTEM

### **[P] 506.1 General.**

Plumbing fixtures shall be properly connected to either a public sewer system or to an *approved* private sewage disposal system.

### **[P] 506.2 Maintenance.**

Every plumbing stack, vent, waste and sewer line shall function properly and be kept free from obstructions, leaks and defects.

**[P] 506.3 Grease interceptors.**

Grease interceptors and automatic grease removal devices shall be maintained in accordance with this code and the manufacturer's installation instructions. Grease interceptors and automatic grease removal devices shall be regularly serviced and cleaned to prevent the discharge of oil, grease, and other substances harmful or hazardous to the building drainage system, the public sewer, the private sewage disposal system or the sewage treatment plant or processes. Records of maintenance, cleaning and repairs shall be available for inspection by the *code official*.

**SECTION 507  
STORM DRAINAGE**

**[P] 507.1 General.**

Drainage of roofs and paved areas, *yards* and courts, and other open areas on the *premises* shall not be discharged in a manner that creates a public nuisance.

**SECTION 508  
SWIMMING POOL DRAINAGE**

**508.1 Method of drainage.**

All existing swimming pools that are not connected to a drainage facility approved by the Oakwood Board of Health or to a drainage facility permissible under the Building Code applicable in this city must be modified or operated so as to dispose of water from those pools in the following manner:

- A. Drainage water must be piped to the nearest available storm sewer; or
- B. Drainage water must be disposed of on the zoning lot on which the pool is situated and in such a manner that it does not drain onto public property or upon private property owned by another person.

## CHAPTER 6 MECHANICAL AND ELECTRICAL REQUIREMENTS

---

### User note:

*About this chapter:* Chapter 6 establishes minimum performance requirements for heating, electrical and mechanical facilities serving existing structures, such as heating and air-conditioning equipment, appliances and their supporting systems; water heating equipment, appliances and systems; cooking equipment and appliances; ventilation and exhaust equipment; gas and liquid fuel distribution piping and components; fireplaces and solid fuel-burning appliances; chimneys and vents; electrical services; lighting fixtures; electrical receptacle outlets; electrical distribution system equipment, devices and wiring; and elevators, escalators and dumbwaiters.

---

### SECTION 601 GENERAL

#### 601.1 Scope.

The provisions of this chapter shall govern the minimum mechanical and electrical facilities and equipment to be provided.

#### 601.2 Responsibility.

The *owner* of the *structure* shall provide and maintain mechanical and electrical facilities and equipment in compliance with these requirements. A person shall not occupy as *owner-occupant* or permit another person to occupy any *premises* that does not comply with the requirements of this chapter.

### SECTION 602 HEATING FACILITIES

#### 602.1 Facilities required.

Heating facilities shall be provided in structures as required by this section.

#### 602.2 Residential occupancies.

Dwellings shall be provided with heating facilities capable of maintaining a room temperature of 68°F (20°C) in all habitable rooms, *bathrooms* and *toilet rooms* based on the winter outdoor design temperature for the locality indicated in Appendix D of the *International Plumbing Code*. Cooking appliances shall not be used, nor shall portable unvented fuel-burning space heaters be used, as a means to provide required heating. The installation of one or more portable space heaters shall not be used to achieve compliance with this section.

**Exception:** In areas where the average monthly temperature is above 30°F (-1°C), a minimum temperature of 65°F (18°C) shall be maintained.

#### 602.3 Heat supply.

Every *owner* and *operator* of any building who rents, leases or lets one or more *dwelling units* or *sleeping units* on terms, either expressed or implied, to furnish heat to the *occupants* thereof shall supply heat during the period from November 1 to March 31 to maintain a minimum temperature of 68°F (20°C) in all habitable rooms, *bathrooms* and *toilet rooms*.

**Exceptions:**

1. When the outdoor temperature is below the winter outdoor design temperature for the locality, maintenance of the minimum room temperature shall not be required provided that the heating system is operating at its full design capacity. The winter outdoor design temperature for the locality shall be as indicated in Appendix D of the *International Plumbing Code*.
2. In areas where the average monthly temperature is above 30°F (-1°C), a minimum temperature of 65°F (18°C) shall be maintained.

**602.4 Occupiable work spaces.**

Indoor occupiable work spaces shall be supplied with heat during the period from November 1 to April 30 to maintain a minimum temperature of 65°F (18°C) during the period the spaces are occupied.

**Exceptions:**

1. Processing, storage and operation areas that require cooling or special temperature conditions.
2. Areas in which persons are primarily engaged in vigorous physical activities.

**602.5 Room temperature measurement.**

The required room temperatures shall be measured 3 feet (914 mm) above the floor near the center of the room and 2 feet (610 mm) inward from the center of each exterior wall.

**SECTION 603  
MECHANICAL EQUIPMENT**

**603.1 Mechanical equipment and appliances.**

Mechanical equipment, appliances, fireplaces, solid fuel-burning appliances, cooking appliances and water heating appliances shall be properly installed and maintained in a safe working condition, and shall be capable of performing the intended function.

**603.2 Removal of combustion products.**

Fuel-burning equipment and appliances shall be connected to an *approved* chimney or vent.

**Exception:** Fuel-burning equipment and appliances that are *labeled* for unvented operation.

**603.3 Clearances.**

Required clearances to combustible materials shall be maintained.

**603.4 Safety controls.**

Safety controls for fuel-burning equipment shall be maintained in effective operation.

**603.5 Combustion air.**

A supply of air for complete combustion of the fuel and for *ventilation* of the space containing the fuel-burning equipment shall be provided for the fuel-burning equipment.

**603.6 Energy conservation devices.**

Devices intended to reduce fuel consumption by attachment to a fuel-burning appliance, to the fuel supply

line thereto, or to the vent outlet or vent piping therefrom, shall not be installed unless *labeled* for such purpose and the installation is specifically *approved*.

## **SECTION 604 ELECTRICAL FACILITIES**

### **604.1 Facilities required.**

Every occupied building shall be provided with an electrical system in compliance with the requirements of this section and Section 605.

### **604.2 Service.**

The size and usage of appliances and equipment shall serve as a basis for determining the need for additional facilities in accordance with NFPA 70. *Dwelling units* shall be served by a three-wire, 120/240 volt, single-phase electrical service having a minimum rating of 60 amperes.

### **604.3 Electrical system hazards.**

Where it is found that the electrical system in a *structure* constitutes a hazard to the *occupants* or the *structure* by reason of inadequate service, improper fusing, insufficient receptacle and lighting outlets, improper wiring or installation, *deterioration* or damage, or for similar reasons, the *code official* shall require the defects to be corrected to eliminate the hazard.

#### **604.3.1 Abatement of electrical hazards associated with water exposure.**

The provisions of this section shall govern the repair and replacement of electrical systems and equipment that have been exposed to water.

##### **604.3.1.1 Electrical equipment.**

Electrical distribution equipment, motor circuits, power equipment, transformers, wire, cable, flexible cords, wiring devices, ground fault circuit interrupters, surge protectors, molded case circuit breakers, low-voltage fuses, luminaires, ballasts, motors and electronic control, signaling and communication equipment that have been exposed to water shall be replaced in accordance with the provisions of the *International Building Code*.

**Exception:** The following equipment shall be allowed to be repaired where an inspection report from the equipment manufacturer or *approved* manufacturer's representative indicates that the equipment has not sustained damage that requires replacement:

1. Enclosed switches, rated not more than 600 volts or less.
2. Busway, rated not more than 600 volts.
3. Panelboards, rated not more than 600 volts.
4. Switchboards, rated not more than 600 volts.
5. Fire pump controllers, rated not more than 600 volts.
6. Manual and magnetic motor controllers.
7. Motor control centers.
8. Alternating current high-voltage circuit breakers.



9. Low-voltage power circuit breakers.
10. Protective relays, meters and current transformers.
11. Low- and medium-voltage switchgear.
12. Liquid-filled transformers.
13. Cast-resin transformers.
14. Wire or cable that is suitable for wet locations and whose ends have not been exposed to water.
15. Wire or cable, not containing fillers, that is suitable for wet locations and whose ends have not been exposed to water.
16. Luminaires that are listed as submersible.
17. Motors.
18. Electronic control, signaling and communication equipment.

**604.3.2 Abatement of electrical hazards associated with fire exposure.**

The provisions of this section shall govern the repair and replacement of electrical systems and equipment that have been exposed to fire.

**604.3.2.1 Electrical equipment.**

Electrical switches, receptacles and fixtures, including furnace, water heating, security system and power distribution circuits, that have been exposed to fire, shall be replaced in accordance with the provisions of the *International Building Code*.

**Exception:** Electrical switches, receptacles and fixtures that shall be allowed to be repaired where an inspection report from the equipment manufacturer or *approved* manufacturer's representative indicates that the equipment has not sustained damage that requires replacement.

## **SECTION 605 ELECTRICAL EQUIPMENT**

**605.1 Installation.**

Electrical equipment, wiring and appliances shall be properly installed and maintained in a safe and *approved* manner.

**605.2 Receptacles.**

Every *habitable space* in a dwelling shall contain not less than two receptacle outlets, though they need not be remote outlets. Instead, these outlets are to be either on separate walls, or if on the same wall, are to be at least twelve feet apart, measured horizontally.

Every laundry area shall contain not less than one grounding-type receptacle or a receptacle with a ground fault circuit interrupter. Every *bathroom* shall contain not less than one receptacle. Any new *bathroom* receptacle outlet shall have ground fault circuit interrupter protection. All receptacle outlets shall have the appropriate faceplate cover for the location.

### **605.3 Luminaires.**

Every public hall, interior stairway, *toilet room*, kitchen, *bathroom*, laundry room, boiler room and furnace room shall contain not less than one electric luminaire. Pool and spa luminaires over 15 V shall have ground fault circuit interrupter protection.

### **605.4 Wiring.**

Flexible cords shall not be used for permanent wiring, or for running through doors, windows, or cabinets, or concealed within walls, floors, or ceilings.

## **SECTION 606 ELEVATORS, ESCALATORS AND DUMBWAITERS**

### **606.1 General.**

Elevators, dumbwaiters and escalators shall be maintained in compliance with ASME A17.1. The most current certificate of inspection shall be on display at all times within the elevator or attached to the escalator or dumbwaiter, be available for public inspection in the office of the building *operator* or be posted in a publicly conspicuous location *approved* by the *code official*. The inspection and tests shall be performed at not less than the periodic intervals listed in ASME A17.1, Appendix N, except where otherwise specified by the authority having jurisdiction.

### **606.2 Elevators.**

In buildings equipped with passenger elevators, not less than one elevator shall be maintained in operation at all times when the building is occupied.

**Exception:** Buildings equipped with only one elevator shall be permitted to have the elevator temporarily out of service for testing or servicing.

## **SECTION 607 DUCT SYSTEMS**

### **607.1 General.**

Duct systems shall be maintained free of obstructions and shall be capable of performing the required function.

## CHAPTER 7 FIRE SAFETY REQUIREMENTS

---

### User note:

*About this chapter:* Chapter 7 establishes fire safety requirements for existing structures by providing requirements for means of egress, including path of travel, required egress width, means of egress doors and emergency escape openings, and for the maintenance of fire-resistance-rated assemblies, fire protection systems, and carbon monoxide alarm and detection systems.

---

### SECTION 701 GENERAL

#### 701.1 Scope.

The provisions of this chapter shall govern the minimum conditions and standards for fire safety relating to structures and exterior *premises*, including fire safety facilities and equipment to be provided.

#### 701.2 Responsibility.

The *owner* of the *premises* shall provide and maintain such fire safety facilities and equipment in compliance with these requirements. A person shall not occupy as *owner-occupant* or permit another person to occupy any *premises* that do not comply with the requirements of this chapter.

### SECTION 702 MEANS OF EGRESS

#### [BE] 702.1 General.

A safe, continuous and unobstructed path of travel shall be provided from any point in a building or *structure* to the *public way*. Means of egress shall comply with the *International Fire Code*.

#### [BE] 702.2 Aisles.

The required width of aisles in accordance with the *International Fire Code* shall be unobstructed.

#### [BE] 702.3 Locked doors.

Means of egress doors shall be readily openable from the side from which egress is to be made without the need for keys, special knowledge or effort, except where the door hardware conforms to that permitted by the *International Building Code*.

#### [BE] 702.4 Emergency escape and rescue openings.

Required emergency escape and rescue openings shall be maintained in accordance with the code in effect at the time of construction, and both of the following:

1. Required emergency escape and rescue openings shall be operational from the inside of the room without the use of keys or tools.
2. Bars, grilles, grates or similar devices are permitted to be placed over emergency escape and rescue openings provided that the minimum net clear opening size complies with the code that was in effect at the time of construction and the unit is equipped with smoke alarms installed in accordance with Section 907.2.10 of the *International Building Code*. Such devices shall be releasable or removable from the inside without the use of a key, tool or force greater than that which is required for normal operation of the escape and rescue opening.

## SECTION 703 FIRE-RESISTANCE RATINGS

### **[BF] 703.1 Fire-resistance-rated assemblies.**

The provisions of this chapter shall govern maintenance of the materials, systems and assemblies used for structural fire resistance and fire-resistance-rated construction separation of adjacent spaces to safeguard against the spread of fire and smoke within a building and the spread of fire to or from buildings.

### **[BF] 703.2 Unsafe conditions.**

Where any components are not maintained and do not function as intended or do not have the fire resistance required by the code under which the building was constructed or altered, such components or portions thereof shall be deemed unsafe conditions in accordance with Section 114.1.1 of the *International Fire Code*. Components or portions thereof determined to be unsafe shall be repaired or replaced to conform to that code under which the building was constructed or altered. Where the condition of components is such that any building, *structure* or portion thereof presents an *imminent danger* to the occupants of the building, *structure* or portion thereof, the *fire code official* shall act in accordance with Section 114.2 of the *International Fire Code*.

### **[BF] 703.3 Maintenance.**

The required fire-resistance rating of fire-resistance-rated construction, including walls, firestops, shaft enclosures, partitions, smoke barriers, floors, fire-resistive coatings and sprayed fire-resistant materials applied to structural members and joint systems, shall be maintained. Such elements shall be visually inspected annually by the *owner* and repaired, restored or replaced where damaged, altered, breached or penetrated. Records of inspections and repairs shall be maintained. Where concealed, such elements shall not be required to be visually inspected by the *owner* unless the concealed space is accessible by the removal or movement of a panel, access door, ceiling tile or entry to the space. Openings made therein for the passage of pipes, electrical conduit, wires, ducts, air transfer and any other reason shall be protected with *approved* methods capable of resisting the passage of smoke and fire. Openings through fire-resistance-rated assemblies shall be protected by self- or automatic-closing doors of *approved* construction meeting the fire protection requirements for the assembly.

#### **[BF] 703.3.1 Fire blocking and draft stopping.**

Required fire blocking and draft stopping in combustibile concealed spaces shall be maintained to provide continuity and integrity of the construction.

#### **[BF] 703.3.2 Smoke barriers and smoke partitions.**

Required smoke barriers and smoke partitions shall be maintained to prevent the passage of smoke. Openings protected with *approved* smoke barrier doors or smoke dampers shall be maintained in accordance with NFPA 105.

#### **[BF] 703.3.3 Fire walls, fire barriers, and fire partitions.**

Required fire walls, fire barriers and fire partitions shall be maintained to prevent the passage of fire. Openings protected with *approved* doors or fire dampers shall be maintained in accordance with NFPA 80.

### **[BF] 703.4 Opening protectives.**

Opening protectives shall be maintained in an operative condition in accordance with NFPA 80. The application of field-applied labels associated with the maintenance of opening protectives shall follow the requirements of the *approved* third-party certification organization accredited for listing the opening protective. Fire doors and smoke barrier doors shall not be blocked or obstructed, or otherwise made

inoperable. Fusible links shall be replaced whenever fused or damaged. Fire door assemblies shall not be modified.

**[BF] 703.4.1 Signs.**

Where required by the *code official*, a sign shall be permanently displayed on or near each fire door in letters not less than 1 inch (25 mm) high to read as follows:

1. For doors designed to be kept normally open: FIRE DOOR – DO NOT BLOCK.
2. For doors designed to be kept normally closed: FIRE DOOR – KEEP CLOSED.

**[BF] 703.4.2 Hold-open devices and closers.**

Hold-open devices and automatic door closers shall be maintained. During the period that such a device is out of service for repairs, the door it operates shall remain in the closed position.

**[BF] 703.4.3 Door operation.**

Swinging fire doors shall close from the full-open position and latch automatically. The door closer shall exert enough force to close and latch the door from any partially open position.

**[BF] 703.5 Ceilings.**

The hanging and displaying of salable goods and other decorative materials from acoustical ceiling systems that are part of a fire-resistance-rated horizontal assembly shall be prohibited.

**[BF] 703.6 Testing.**

Horizontal and vertical sliding and rolling fire doors shall be inspected and tested annually to confirm operation and full closure. Records of inspections and testing shall be maintained.

**[BF] 703.7 Vertical shafts.**

Interior vertical shafts, including stairways, elevator hoistways and service and utility shafts, which connect two or more stories of a building shall be enclosed or protected as required in Chapter 11 of the *International Fire Code*. New floor openings in existing buildings shall comply with the *International Building Code*.

**[BF] 703.8 Opening protective closers.**

Where openings are required to be protected, opening protectives shall be maintained self-closing or automatic-closing by smoke detection. Existing fusible-link-type automatic door-closing devices shall be replaced if the fusible link rating exceeds 135°F (57°C).

**SECTION 704  
FIRE PROTECTION SYSTEMS**

**[F] 704.1 Inspection, testing and maintenance.**

Fire protection and life safety systems shall be maintained in accordance with the *International Fire Code* in an operative condition at all times, and shall be replaced or repaired where defective.

**[F] 704.1.1 Fire protection and life safety systems.**

Fire protection and life safety systems shall be installed, repaired, operated and maintained in accordance with this code the *International Fire Code* and the *International Building Code*.

**[F] 704.1.2 Required fire protection and life safety systems.**

Fire protection and life safety systems required by this code, the *International Fire Code* or the

*International Building Code* shall be installed, repaired, operated, tested and maintained in accordance with this code. A fire protection and life safety system for which a design option, exception or reduction to the provisions of this code, the *International Fire Code* or the *International Building Code* has been granted shall be considered to be a required system.

**[F] 704.1.3 Fire protection systems.**

Fire protection systems shall be inspected, maintained and tested in accordance with the following *International Fire Code* requirements.

1. Automatic sprinkler systems, see Section 903.5.
2. Automatic fire-extinguishing systems protecting commercial cooking systems, see Section 904.13.5.
3. Automatic water mist extinguishing systems, see Section 904.11.
4. Carbon dioxide extinguishing systems, see Section 904.8.
5. Carbon monoxide alarms and carbon monoxide detection systems, see Section 915.6.
6. Clean-agent extinguishing systems, see Section 904.10.
7. Dry-chemical extinguishing systems, see Section 904.6.
8. Fire alarm and fire detection systems, see Section 907.8.
9. Fire department connections, see Sections 912.4 and 912.7.
10. Fire pumps, see Section 913.5.
11. Foam extinguishing systems, see Section 904.7.
12. Halon extinguishing systems, see Section 904.9.
13. Single- and multiple-station smoke alarms, see Section 907.10.
14. Smoke and heat vents and mechanical smoke removal systems, see Section 910.5.
15. Smoke control systems, see Section 909.22.
16. Wet-chemical extinguishing systems, see Section 904.5.

**[F] 704.2 Standards.**

Fire protection systems shall be inspected, tested and maintained in accordance with the referenced standards listed in Table 704.2 and as required in this section.

**TABLE 704.2  
FIRE PROTECTION SYSTEM MAINTENANCE STANDARDS**

SYSTEM	STANDARD
Portable fire extinguishers	NFPA 10
Carbon dioxide fire-extinguishing system	NFPA 12
Halon 1301 fire-extinguishing systems	NFPA 12A
Dry-chemical extinguishing systems	NFPA 17
Wet-chemical extinguishing systems	NFPA 17A
Water-based fire protection systems	NFPA 25
Fire alarm systems	NFPA 72
Smoke and heat vents	NFPA 204
Water-mist systems	NFPA 750
Clean-agent extinguishing systems	NFPA 2001

**[F] 704.2.1 Records.**

Records shall be maintained of all system inspections, tests and maintenance required by the referenced standards.

**[F] 704.2.2 Records information.**

Initial records shall include the: name of the installation contractor; type of components installed; manufacturer of the components; location and number of components installed per floor; and manufacturers' operation and maintenance instruction manuals. Such records shall be maintained for the life of the installation.

**[F] 704.3 Systems out of service.**

Where a required fire protection system is out of service, the fire department and the fire *code official* shall be notified immediately and, where required by the fire *code official*, either the building shall be evacuated or an *approved* fire watch shall be provided for all *occupants* left unprotected by the shutdown until the fire protection system has been returned to service. Where utilized, fire watches shall be provided with not less than one *approved* means for notification of the fire department and shall not have duties beyond performing constant patrols of the protected *premises* and keeping watch for fires. Actions shall be taken in accordance with Section 901 of the *International Fire Code* to bring the systems back in service.

**Exception:** Facilities with an approved notification and impairment management program. The notification and impairment program for water-based fire protection systems shall comply with NFPA 25.

**[F] 704.3.1 Emergency impairments.**

Where unplanned impairments of fire protection systems occur, appropriate emergency action shall be taken to minimize potential injury and damage. The impairment coordinator shall implement the steps outlined in Section 901.7.4 of the *International Fire Code*.

**[F] 704.4 Removal of or tampering with equipment.**

It shall be unlawful for any person to remove, tamper with or otherwise disturb any fire protection or life safety system required by this code except for the purposes of extinguishing fire, training, recharging or making necessary repairs.

**[F] 704.4.1 Removal of or tampering with appurtenances.**

Locks, gates, doors, barricades, chains, enclosures, signs, tags and seals that have been installed by or at the direction of the fire *code official* shall not be removed, unlocked, destroyed or tampered with in any manner.

**[F] 704.4.2 Removal of existing occupant-use hose lines.**

The fire *code official* is authorized to permit the removal of existing occupant-use hose lines where all of the following apply:

1. The installation is not required by the *International Fire Code* or the *International Building Code*.
2. The hose line would not be utilized by trained personnel or the fire department.
3. The remaining outlets are compatible with local fire department fittings.

**[F] 704.4.3 Termination of monitoring service.**

For fire alarm systems required to be monitored by the *International Fire Code*, notice shall be made to the fire *code official* whenever alarm monitoring services are terminated. Notice shall be made in writing by the provider of the monitoring service being terminated.

**[F] 704.5 Fire department connection.**

Where the fire department connection is not visible to approaching fire apparatus, the fire department connection shall be indicated by an *approved* sign mounted on the street front or on the side of the building. Such sign shall have the letters “FDC” not less than 6 inches (152 mm) high and words in letters not less than 2 inches (51 mm) high or an arrow to indicate the location. Such signs shall be subject to the approval of the fire *code official*.

**[F] 704.5.1 Fire department connection access.**

Ready access to fire department connections shall be maintained at all times and without obstruction by fences, bushes, trees, walls or any other fixed or movable object. Access to fire department connections shall be *approved* by the fire chief.

**Exception:** Fences, where provided with an access gate equipped with a sign complying with the legend requirements of Section 912.5 of the *International Fire Code* and a means of emergency operation. The gate and the means of emergency operation shall be *approved* by the fire chief and maintained operational at all times.

**[F] 704.5.2 Clear space around connections.**

A working space of not less than 36 inches (914 mm) in width, 36 inches (914 mm) in depth and 78 inches (1981 mm) in height shall be provided and maintained in front of and to the sides of wall-mounted fire department connections and around the circumference of free-standing fire department connections.

**[F] 704.6 Single- and multiple-station smoke alarms.**

Single- and multiple-station smoke alarms shall be installed in existing Group I-1 and R *occupancies* in accordance with Sections 704.6.1 through 704.6.3.

**[F] 704.6.1 Where required.**

Existing Group I-1 and R *occupancies* shall be provided with single-station smoke alarms in



accordance with Sections 704.6.1.1 through 704.6.1.4. Interconnection and power sources shall be in accordance with Sections 704.6.2 and 704.6.3.

**Exceptions:**

1. Where the code that was in effect at the time of construction required smoke alarms and smoke alarms complying with those requirements are already provided.
2. Where smoke alarms have been installed in occupancies and dwellings that were not required to have them at the time of construction, additional smoke alarms shall not be required provided that the existing smoke alarms comply with requirements that were in effect at the time of installation.
3. Where smoke detectors connected to a fire alarm system have been installed as a substitute for smoke alarms.

**[F] 704.6.1.1 Group R-1.**

Single- or multiple-station smoke alarms shall be installed in all of the following locations in Group R-1:

1. In sleeping areas.
2. In every room in the path of the *means of egress* from the sleeping area to the door leading from the *sleeping unit*.
3. In each story within the *sleeping unit*, including *basements*. For *sleeping units* with split levels and without an intervening door between the adjacent levels, a smoke alarm installed on the upper level shall suffice for the adjacent lower level provided that the lower level is less than one full story below the upper level.

**[F] 704.6.1.2 Groups R-2, R-3, R-4 and I-1.**

Single or multiple-station smoke alarms shall be installed and maintained in Groups R-2, R-3, R-4 and I-1 regardless of *occupant load* at all of the following locations:

1. On the ceiling or wall outside of each separate sleeping area in the immediate vicinity of bedrooms.
2. In each room used for sleeping purposes.
3. In each story within a *dwelling unit*, including *basements* but not including crawl spaces and uninhabitable attics. In *dwellings* or *dwelling units* with split levels and without an intervening door between the adjacent levels, a smoke alarm installed on the upper level shall suffice for the adjacent lower level provided that the lower level is less than one full story below the upper level.

**[F] 704.6.1.3 Installation near cooking appliances.**

Smoke alarms shall not be installed in the following locations unless this would prevent placement of a smoke alarm in a location required by Section 704.6.1.1 or 704.6.1.2.

1. Ionization smoke alarms shall not be installed less than 20 feet (6096 m) horizontally from a permanently installed cooking appliance.

2. Ionization smoke alarms with an alarm-silencing switch shall not be installed less than 10 feet (3048 mm) horizontally from a permanently installed cooking appliance.
3. Photoelectric smoke alarms shall not be installed less than 6 feet (1829 mm) horizontally from a permanently installed cooking appliance.

**[F] 704.6.1.4 Installation near bathrooms.**

Smoke alarms shall be installed not less than 3 feet (914 mm) horizontally from the door or opening of a *bathroom* that contains a bathtub or shower unless this would prevent placement of a smoke alarm required by Section 704.6.1.1 or 704.6.1.2.

**[F] 704.6.2 Interconnection.**

Where more than one smoke alarm is required to be installed within an individual *dwelling* or *sleeping unit*, the smoke alarms shall be interconnected in such a manner that the activation of one alarm will activate all of the alarms in the individual unit. Physical interconnection of smoke alarms shall not be required where listed wireless alarms are installed and all alarms sound upon activation of one alarm. The alarm shall be clearly audible in all bedrooms over background noise levels with all intervening doors closed.

**Exceptions:**

1. Interconnection is not required in buildings that are not undergoing *alterations*, repairs or construction of any kind.
2. Smoke alarms in existing areas are not required to be interconnected where *alterations* or repairs do not result in the removal of interior wall or ceiling finishes exposing the structure, unless there is an attic, crawl space or *basement* available that could provide access for interconnection without the removal of interior finishes.

**[F] 704.6.3 Power source.**

Single-station smoke alarms shall receive their primary power from the building wiring provided that such wiring is served from a commercial source and shall be equipped with a battery backup. Smoke alarms with integral strobes that are not equipped with battery backup shall be connected to an emergency electrical system. Smoke alarms shall emit a signal when the batteries are low. Wiring shall be permanent and without a disconnecting switch other than as required for overcurrent protection.

**Exceptions:**

1. Smoke alarms are permitted to be solely battery operated in existing buildings where construction is not taking place.
2. Smoke alarms are permitted to be solely battery operated in buildings that are not served from a commercial power source.
3. Smoke alarms are permitted to be solely battery operated in existing areas of buildings undergoing *alterations* or repairs that do not result in the removal of interior walls or ceiling finishes exposing the structure, unless there is an attic, crawl space or *basement* available that could provide access for building wiring without the removal of interior finishes.

**[F] 704.6.4 Smoke detection system.**

Smoke detectors listed in accordance with UL 268 and provided as part of the building's fire alarm system shall be an acceptable alternative to single- and multiple-station smoke alarms and shall comply with the following:

1. The fire alarm system shall comply with all applicable requirements in Section 907 of the *International Fire Code*.
2. Activation of a smoke detector in a dwelling or sleeping unit shall initiate alarm notification in the *dwelling* or *sleeping unit* in accordance with Section 907.5.2 of the *International Fire Code*.
3. Activation of a smoke detector in a *dwelling* or *sleeping unit* shall not activate alarm notification appliances outside of the *dwelling* or *sleeping unit*, provided that a supervisory signal is generated and monitored in accordance with Section 907.6.6 of the *International Fire Code*.

**[F] 704.7 Single- and multiple-station smoke alarms.**

Single- and multiple-station smoke alarms shall be tested and maintained in accordance with the manufacturer's instructions. Smoke alarms that do not function shall be replaced. Smoke alarms installed in one- and two-family dwellings shall be replaced not more than 10 years from the date of manufacture marked on the unit, or shall be replaced if the date of manufacture cannot be determined.

**SECTION 705  
CARBON MONOXIDE ALARMS AND DETECTION**

**[F] 705.1 General.**

Carbon monoxide alarms shall be installed in dwellings in accordance with Section 1103.9 of the *International Fire Code*, except that alarms in dwellings covered by the *International Residential Code* shall be installed in accordance with Section R315 of that code.

**[F] 705.2 Carbon monoxide alarms and detectors.**

Carbon monoxide alarms and carbon monoxide detection systems shall be maintained in accordance with NFPA 720. Carbon monoxide alarms and carbon monoxide detectors that become inoperable or begin producing end-of-life signals shall be replaced.

**CHAPTER 8  
RESIDENTIAL RENTALS**

**800.1 Inspection.**

- A. As soon as reasonably practicable after the tenants have vacated a dwelling unit, the commissioner of buildings shall cause an inspection of the dwelling unit and any other areas of the premises available for use by the tenants of that dwelling unit (hereinafter called "accessory property") to be made as described elsewhere in this Property Maintenance Code.
- B. At the time notice of change of occupancy of any dwelling unit is given, the owner or operator of the dwelling shall complete an inspection form and schedule an appointment for a time during normal business hours in order for the owner or operator to admit the code official or a representative thereof.
- C. The owner or operator of a premise with a rental unit is subject to have the interior of its structures and rental units inspected, at any time, in response to a complaint of an alleged violation of any of the provisions of this Chapter or the provisions of the application of city of Oakwood Codes. For purposes of this provision, a complaint shall be deemed "received" if it is: a. Submitted in writing; b. Includes a description of the real estate or dwelling sufficient for identification; c. Includes the name of the landlord, managing agent, or operator and contact information sufficient to contact the owner, operator, or agent; d. Includes a clear statement of the alleged violation or condition that leads to the belief that a violation exists.
- D. The owner of a rental unit shall pay an inspection fee for any interior inspection performed as required by subsection B of this section, except as exempted under E below. The amount of the fee shall initially be \$50.00 per unit inspected, but shall subsequently be reviewed and increased if the City Manager determines it necessary to cover the cost of the inspection.
- E. No fee shall be required for an interior inspection prompted by a complaint submitted under Subsection C unless violations are noted at which time the property owner will be charged an inspection fee as established by subsection D above. F. Money collected under this Section shall be used exclusively for rental unit inspection purposes.

**800.2 Access to Unit.**

- A. Access by Owner or Operator. Every occupant of a rental unit shall give, upon proper notice, the owner or operator thereof, or his/her agent or employee, access to any part of such rental unit at all reasonable times for the purpose of effecting such maintenance, making such repairs or making such alterations as are necessary to effect compliance with any lawful notice or order issued pursuant to the provisions of the applicable city of Oakwood Codes.
- B. Access by Code Official. The Code Official or his/her duly authorized designee is hereby authorized to conduct inspections of any rental unit within the city of Oakwood in order to perform the duty of safeguarding the health, safety and welfare of the occupants and the public under the provisions of this chapter. Whenever necessary to make an inspection to enforce any of the provisions of this Chapter or the provisions of the Codified Ordinances of the city of Oakwood or whenever the Code Official or his/her duly authorized designee has probable cause to believe that there exists in any rental unit any condition which makes such rental unit in violation of any of the provisions of this Chapter or the provisions of the applicable city of Oakwood codes, the Code Official or his/her duly authorized designee may enter such rental unit at all reasonable times to inspect the same or to perform any duty imposed upon the Code Official by this Chapter or other

applicable provisions of the Codified Ordinances of Oakwood. If such rental unit is occupied, the Code Official shall first make a reasonable effort to locate the occupant, giving at least 24-hour notice of intent to inspect the premises and at least 24-hour notice of right to refuse entry. For purposes of Section 106 of the Property Maintenance Code, it shall be a violation of Section 800 et seq. to willfully refuse to respond to a notice of intent to inspect the premises. It shall not be a violation of any Ordinance of the city of Oakwood to reasonably refuse to permit entry to a Code Official upon notice. After provision of the 24-hour notice of intent to inspect, the Code Official or his/her duly authorized design shall at such time:

1. Identify himself/herself and his/her position;
  2. Explain why entry is sought;
  3. Explain that the owner/operator or tenant of an occupied rental unit or other person(s) having charge or control of an unoccupied rental unit may refuse, without penalty, entry without a search warrant;
  4. Provide documentation of written notice to the owner/operator giving 7- day notice of deficiency. (Such notice shall not be construed to imply that the repairs need to be completed at that time.)
- C. Search Warrant. If consent to inspect a rental unit is withheld by any person or persons having the lawful right to exclude, the Code Official or his/her duly authorized designee may apply to a court of competent jurisdiction for a search warrant of the rental unit. No owner/operator or occupant or any person having charge, care or control of a rental unit shall fail or neglect, after presentation of a search warrant, to properly permit entry therein by the Official or his/her duly authorized designee for the purpose of inspection and examination pursuant to this Chapter.

### **800.3 Supplementation of Information Filed With County Auditor Pursuant to RC § 5323.**

Within fifteen (15) days of mailing of the city of Oakwood's request for tenant information, and within fifteen (15) days after any change of tenant(s) occupying the property, the owner of residential rental property shall submit to the code official, on the form provided, the following information for each tenant occupying each residential rental property registered with the County Auditor pursuant to Ohio Revised Code § 5323:

1. Each tenant's full name;
2. Each tenant's relationship, or lack thereof, to any other persons residing in the same dwelling unit;
3. The date on which each tenant's occupancy commenced; and
4. A valid telephone number that can be used by the City to contact tenants directly in case of emergency or other problem. (It is not necessary to provide separate telephone numbers for each tenant, so long as at least one telephone number is provided.) Failure to properly register the property with the County Auditor shall not relieve the owner of the reporting obligation under this section.

### **801 Short-term Rentals Prohibited.**

#### **801.1 Purpose.**

Council of the city of Oakwood has determined that the short-term rental of residential property is inconsistent with the permanence, established character, density, and tranquility of Oakwood's residential neighborhoods and is potentially detrimental to property values. The purpose and intent of this ordinance is to prohibit short-term rentals to protect and preserve these qualities of Oakwood's residential neighborhoods and to provide for the comfort, safety, and welfare of Oakwood residents.

#### **801.2 Definitions.**

- A. “Transient Occupancy” means the right to use, occupy or possess, or the actual use, occupancy or possession, of the following, as defined by the Oakwood Zoning Ordinance: a Dwelling Unit, Single Family Dwelling, Two Family Dwelling, or Multiple-Family Dwelling; or a portion of any of the aforementioned; for a period of twenty five (25) consecutive calendar days or less.
- B. “Transient Rental” means the renting, letting, subletting, leasing or subleasing of the following, as defined by the Oakwood Zoning Ordinance: a Dwelling Unit, Single Family Dwelling, Two Family Dwelling, or Multiple Family Dwelling; or a portion of any of the aforementioned; for Transient Occupancy use.

**801.3 Prohibition.**

On or after January 1, 2020, no person shall operate, let, list, advertise, or otherwise make available, any residential property in the city of Oakwood for Transient Rental purposes.

**CHAPTER 9**  
**REFERENCED STANDARDS**

---

**User note:**

*About this chapter:* This code contains numerous references to standards promulgated by other organizations that are used to provide requirements for materials and methods of construction. Chapter 8 contains a comprehensive list of all standards that are referenced in this code. These standards, in essence, are part of this code to the extent of the reference to the standard.

*This chapter lists the standards that are referenced in various sections of this document. The standards are listed herein by the promulgating agency of the standard, the standard identification, the effective date and title and the section or sections of this document that reference the standard. The application of the referenced standards shall be as specified in Section 102.8.*

---

---

<b>ASME</b>	American Society of Mechanical Engineers Two Park Avenue New York, NY 10016-5990
-------------	--

**ASME A17.1—2019/CSA B44—19: Safety Code for Elevators and Escalators**  
606.1

---

<b>ASTM</b>	ASTM International 100 Barr Harbor Drive, P.O. Box C700 West Conshohocken, PA 19428-2959
-------------	--

**F1346—91 (2018): Performance Specifications for Safety Covers and Labeling Requirements for All Covers for Swimming Pools, Spas and Hot Tubs**  
303.2

---

<b>ICC</b>	International Code Council 500 New Jersey Avenue, NW 6th Floor Washington, DC 20001
------------	--

**IBC—21: International Building Code**<sup>®</sup>  
102.3, 201.3, 304.1.1, 305.1.1, 306.1.1, 403.1, 604.3.1.1,  
604.3.2.1, 702.3, 704.4.2

**IEBC—21: International Existing Building Code**<sup>®</sup>  
102.3, 201.3, 304.1.1, 305.1.1, 306.1.1

**IECC—21: International Energy Conservation Code**<sup>®</sup>  
102.3

**IFC—21: International Fire Code**<sup>®</sup>  
102.3, 201.3, 604.3.1.1, 702.1, 702.2, 704.1, 704.1.2, 704.1.3,  
704.3, 704.3.1, 704.4.2, 704.4.3, 704.5.1, 704.6.4, 705.1

- IFGC—21: International Fuel Gas Code**<sup>®</sup>  
102.3, 201.3
- IMC—21: International Mechanical Code**<sup>®</sup>  
102.3, 201.3
- IPC—21: International Plumbing Code**<sup>®</sup>  
102.3, 201.3, 502.5, 505.1, 505.5.1, 602.2, 602.3
- IRC—21: International Residential Code**<sup>®</sup>  
102.3, 201.3
- IZC—21: International Zoning Code**<sup>®</sup>  
102.3, 201.3

---

**NFPA**

National Fire Protection  
Association  
1 Batterymarch Park  
Quincy, MA  
02169-7471

- 10—21: Standard for Portable Fire Extinguishers**  
Table 704.2
- 12—18: Standard on Carbon Dioxide Extinguishing Systems**  
Table 704.2
- 12A—18: Standard on Halon 1301 Fire Extinguishing Systems**  
Table 704.2
- 17—20: Standard for Dry Chemical Extinguishing Systems**  
Table 704.2
- 17A—20: Standard for Wet Chemical Extinguishing Systems**  
Table 704.2
- 25—20: Standard for the Inspection, Testing and Maintenance of Water-Based Fire Protection Systems**  
Table 704.2
- 70—20: National Electrical Code**  
102.3, 201.3, 604.2
- 72—19: National Fire Alarm and Signaling Code**  
Table 704.2
- 80—19: Standard for Fire Doors and Other Opening Protectives**  
703.3.3, 703.4
- 105—19: Standard for Smoke Door Assemblies and Other Opening Protectives**  
703.3.2
- 204—18: Standard for Smoke and Heat Venting**  
Table 704.2
- 720—15: Standard for the Installation of Carbon Monoxide (CO) Detection and Warning Equipment**  
705.2
- 750—19: Standard on Water Mist Fire Protection Systems**  
Table 704.2
- 2001—18: Standard on Clean Agent Fire Extinguishing Systems**  
Table 704.2



---

**UL**

Underwriters  
Laboratories, LLC  
333 Pfingsten Road  
Northbrook, IL 60062

**268—2016: Smoke Detectors for Fire Alarm Systems—with revisions through July 2016**  
704.6.4

## APPENDIX A BOARDING STANDARD

*The provisions contained in this appendix are not mandatory unless specifically referenced in the adopting ordinance.*

---

### User note:

***About this appendix:** Appendix A provides minimum specifications for boarding a structure. This can be utilized by a jurisdiction as a set of minimum requirements in order to result in consistent boarding quality. These requirements also provide a reasonable means to eliminate having to approve numerous methods or materials for the boarding and securing of a structure. It is important to note that the provisions of Appendix A are not mandatory unless specifically referenced in the adopting ordinance of the authority having jurisdiction.*

---

### A101 GENERAL

#### A101.1 General.

Windows and doors shall be boarded in an *approved* manner to prevent entry by unauthorized persons and shall be painted to correspond to the color of the existing *structure*.

### A102 MATERIALS

#### A102.1 Boarding sheet material.

Boarding sheet material shall be minimum  $\frac{1}{2}$ -inch-thick (12.7 mm) wood structural panels complying with the *International Building Code*.

#### A102.2 Boarding framing material.

Boarding framing material shall be minimum nominal 2-inch by 4-inch (51 mm by 102 mm) solid sawn lumber complying with the *International Building Code*.

#### A102.3 Boarding fasteners.

Boarding fasteners shall be minimum  $\frac{3}{8}$ -inch-diameter (9.5 mm) carriage bolts of such a length as required to penetrate the assembly and as required to adequately attach the washers and nuts. Washers and nuts shall comply with the *International Building Code*.

## A103 INSTALLATION

### A103.1 Boarding installation.

The boarding installation shall be in accordance with Figures A103.1(1) and A103.1(2) and Sections A103.2 through A103.5.

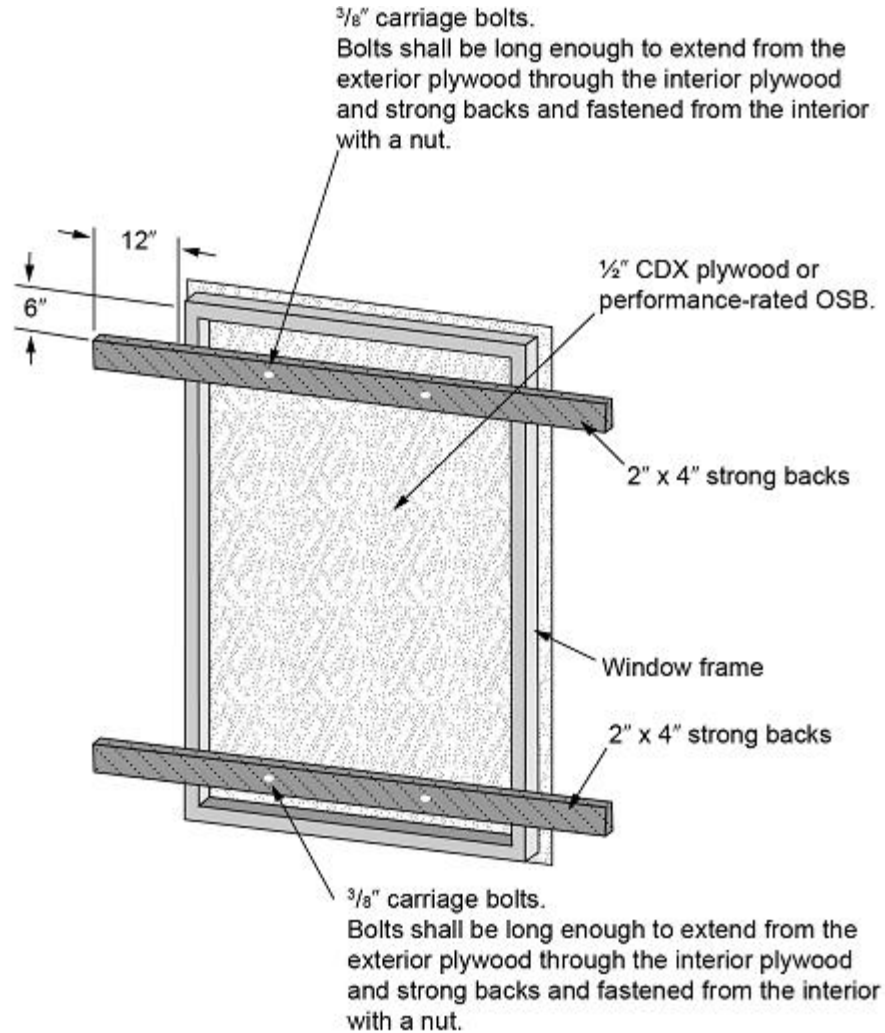

For SI: 1 inch = 25.4 mm.

**FIGURE A103.1(1)  
BOARDING OF DOOR OR WINDOW**

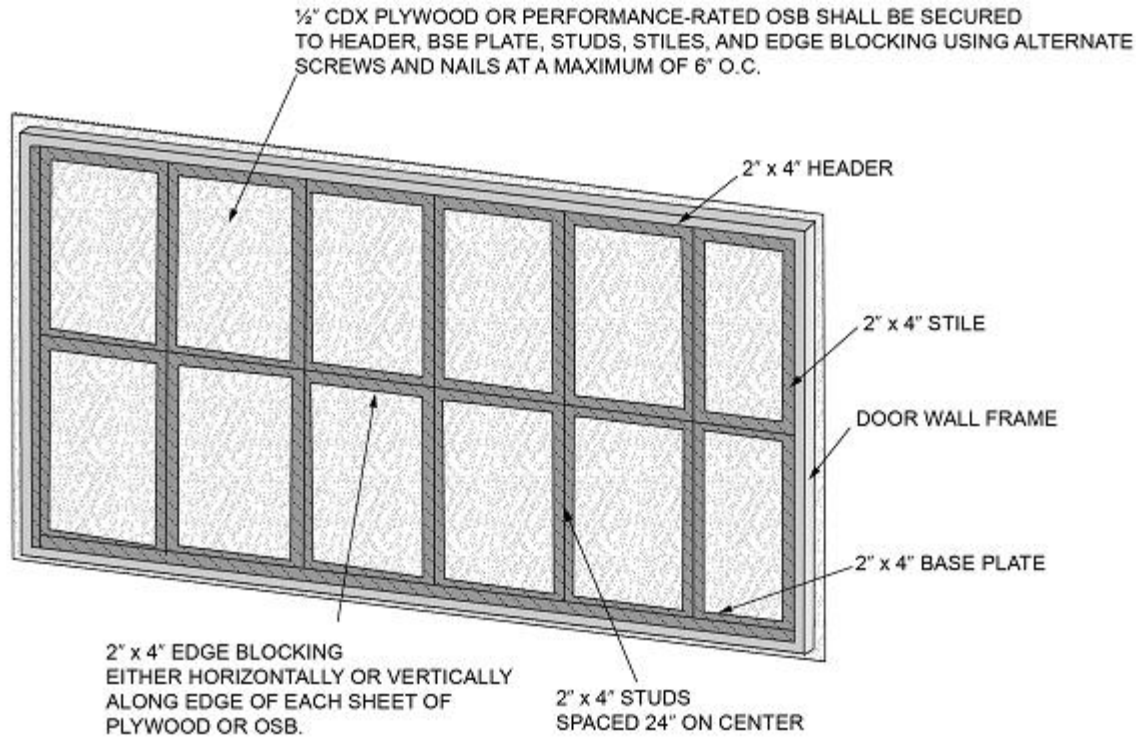

For SI: 1 inch = 25.4 mm

**FIGURE A103.1(2)  
BOARDING OF DOOR WALL**

**A103.2 Boarding sheet material.**

The boarding sheet material shall be cut to fit the door or window opening neatly or shall be cut to provide an equal overlap at the perimeter of the door or window.

**A103.3 Windows.**

The window shall be opened to allow the carriage bolt to pass through or the window sash shall be removed and stored. The 2-inch by 4-inch (51 mm by 102 mm) strong back framing material shall be cut minimum 2 inches (51 mm) wider than the window opening and shall be placed on the inside of the window opening 6 inches (152 mm) minimum above the bottom and below the top of the window opening. The framing and boarding shall be predrilled. The assembly shall be aligned and the bolts, washers and nuts shall be installed and secured.

**A103.4 Door walls.**

The door opening shall be framed with minimum 2-inch by 4-inch (51 mm by 102 mm) framing material secured at the entire perimeter and vertical members at a maximum of 24 inches (610 mm) on center. Blocking shall also be secured at a maximum of 48 inches (1219 mm) on center vertically. Boarding sheet material shall be secured with screws and nails alternating every 6 inches (152 mm) on center.

**A103.5 Doors.**

Doors shall be secured by the same method as for windows or door openings. One door to the *structure* shall be available for authorized entry and shall be secured and locked in an *approved* manner.

**A104**  
**REFERENCED STANDARD**

**A104.1 Referenced standards.**

Table A104.1 lists the standard that is referenced in various sections of this appendix. The standard is listed herein by the standard identification, the effective date and title and the section or sections of this document that reference the standard. The application of the referenced standards shall be as specified in Section 102.8.

**TABLE A104.1**  
**REFERENCED STANDARD**

<b>STANDARD ACRONYM</b>	<b>STANDARD NAME</b>	<b>SECTIONS HEREIN REFERENCED</b>
IBC—21	International Building Code	A102.1, A102.2, A102.3

**APPENDIX B  
(DELETED)**

## INDEX

### A

#### ACCESS

- Emergency egress . . . . . 702
- From bedrooms . . . . . 404.4.2
- Plumbing fixtures, access for cleaning . . . . . 504.2
- To public way . . . . . 702.1
- Toilet room as passageway . . . . . 503.1
- Water closet . . . . . 404.4.3

#### ADJACENT

- Privacy (hotel units, rooming units). . . . . 404.1

#### ADMINISTRATION

- Scope . . . . . 101.2

#### AIR

- Combustion air . . . . . 603.5

#### AISLES

- Minimum width . . . . . 702.2

#### ALTERATION

- Applicability of other codes. . . . . 102.3
- Inspection . . . . . 105.2
- Prosecution. . . . . 109.3
- Unlawful acts . . . . . 109.1

#### ANCHOR

- Anchored, definition . . . . . 202
- Architectural trim. . . . . 304.8
- Signs, marquees and awnings . . . . . 304.9
- Unsafe conditions . . . . . 304.1.1

#### APPEAL

- Application . . . . . 107.2
- Board of appeals . . . . . 108.1
- Hearing, emergency orders . . . . . 112.6
- Membership . . . . . 108.1
- Notice of appeal . . . . . 107.2
- Records . . . . . 105.6
- Right to appeal . . . . . 107.2

#### APPLIANCE

- Cooking . . . . . 403.3, 602.2
- Mechanical . . . . . 603.1

**APPLICABILITY**

- Application of references . . . . .102.10
- General . . . . .102.1
- Other laws. . . . . 102.11
- Referenced codes and standards. . . . . 102.8

**APPROVAL**

- Alternatives . . . . . 106.2
- Authority . . . . . 105.1, 106.2
- Modifications. . . . . 106.1
- Research reports . . . . . 106.6
- Used material and equipment . . . . . 106.4

**APPROVED**

- Alternative materials, methods and equipment . . . . . 106.2
- Definition. . . . . 202
- Energy conservation devices . . . . . 603.6
- Garbage storage facilities . . . . . 308.3.1
- Modifications. . . . . 106.1
- Used materials and equipment . . . . . 106.4

**ARTIFICIAL**

- Lighting of habitable rooms. . . . . 401.3
- Lighting of other spaces . . . . . 402.3

**AUTOMOBILE**

- Motor vehicles. . . . . 302.8

**AWNING**

- Signs, marquees and awnings . . . . . 304.9

**B**

**BALCONY**

- Handrails and guardrails . . . . . 304.12

**BASEMENT**

- Definition. . . . . 202
- Hatchways . . . . . 304.16
- Windows . . . . . 304.17

**BATHROOM**

- Common bathrooms . . . . . 502.3, 503.1
- Hotels . . . . . 502.3
- Lighting . . . . . 605.3
- Locks. . . . . 503.1
- Outlets required . . . . . 605.2
- Privacy . . . . . 503.1
- Ventilation . . . . . 403.2



**BATHTUB**

- Dwelling units . . . . . 502.1
- Rooming houses. . . . . 502.2
- Sewage system. . . . . 506.1
- Water system . . . . . 505.1
- Water-heating facilities . . . . . 505.4

**BOARDING**

- Boarding standard. . . . . Appendix A

**BOILER**

- Unsafe equipment . . . . . 111.1.2

**C**

**CAPACITY**

- Heating facilities. . . . . 602.2, 602.3, 602.4

**CARBON MONOXIDE ALARMS AND DETECTION**

- Installation . . . . . 705.1
- Maintenance . . . . . 705.2

**CEILING**

- Basement rooms . . . . . 404.3
- Fire-resistance ratings . . . . . 703.1
- Interior surfaces . . . . . 305.3
- Minimum height . . . . . 404.3
- Sleeping rooms . . . . . 404.3

**CHANGE, MODIFY**

- Application of other codes . . . . . 102.3

**CHIMNEY**

- Exterior structure . . . . . 304.11
- Flue . . . . . 603.2, 603.3

**CLEANING**

- Access for cleaning . . . . . 504.2
- Disposal of garbage. . . . . 308.3
- Disposal of rubbish . . . . . 308.2
- Interior and exterior sanitation . . . . . 308.1
- Interior surfaces . . . . . 305.3
- Plumbing facilities, maintained . . . . . 504.1
- Required plumbing facilities. . . . . 502
- Responsibility of persons. . . . . 305.1
- Trash containers . . . . . 308.3.2
- Vacant structures and land . . . . . 301.3

**CLEARANCE**

- Heating facilities. . . . . 603.3
- Plumbing fixtures . . . . . 504.2

**CLOSING**

- Streets . . . . . 112.3
- Vacant structures. . . . . 111.2

**CLOTHES DRYER**

- Exhaust . . . . . 403.5

**CODE OFFICIAL**

- Condemnation . . . . . 111.1
- Demolition . . . . . 113
- Duties. . . . . 105
- Emergency order . . . . . 112
- Enforcement authority . . . . . 105.1
- Failure to comply with demolition order . . . . . 113.3
- Identification. . . . . 105.3
- Inspections. . . . . 105.2
- Liability, relief of personal. . . . . 105.7
- Membership of board of appeals . . . . . 108.1
- Notice of violation. . . . . 105.5, 107
- Official records . . . . . 105.6
- Personal liability . . . . . 105.7
- Placarding . . . . . 111.7
- Prosecution . . . . . 109.3
- Removal of placard . . . . . 111.7.1
- Right of entry . . . . . 105.3
- Transfer of ownership . . . . . 111.6
- Vacant structures . . . . . 111.2
- Voting of appeals board . . . . . 108.1

**COMBUSTION**

- Combustion air . . . . . 603.5

**COMPONENT SERVICEABILITY**

- Unsafe conditions. . . . . 306.1.1

**CONDEMNATION**

- Closing of vacant structures. . . . . 111.2
- Failure to comply . . . . . 113.3
- General . . . . . 111.1
- Notices and orders . . . . . 111.2, 111.3
- Placarding . . . . . 111.7
- Removal of placard . . . . . 111.7.1

**CONFLICT**

- Conflict of interest . . . . . 109.1.3
- Violations . . . . . 109.1

**CONNECTION**

- Sewage system . . . . . 506.1
- Water heating. . . . . 505.4
- Water system. . . . . 505.1

**CONSTRUCTION**

Existing structures . . . . . 101.2

**CONTAINER**

Garbage . . . . . 308.3.2

Rubbish storage. . . . . 308.2.1

**CONTINUOUS**

Unobstructed egress . . . . . 702.1

**CONTROL**

Rodent control . . . . . 302.5, 304.5

Safety controls . . . . . 603.4

Weed . . . . . 302.4

**COOLING**

Cooling towers . . . . . 304.11

**CORRIDOR**

Accumulation of rubbish. . . . . 308.1

Light . . . . . 402.2

Lighting fixtures . . . . . 605.3

Obstructions. . . . . 702.1, 702.2

Ratings maintained . . . . . 703

**COST OF SUCH DEMOLITION OR EMERGENCY**

**REPAIRS** . . . . . 202

**D**

**DAMP, DAMPNESS**

Roofs . . . . . 304.7

Window, door frames . . . . . 304.13

**DANGEROUS, HAZARDOUS**

Condemnation . . . . . 111.1

Demolition. . . . . 113

Electrical hazards . . . . . 604.3, 604.3.1

Existing remedies . . . . . 102.4

Imminent danger. . . . . 202

Unsafe equipment . . . . . 111.1.2

Unsafe structures or premises . . . . . 111.1.5

**DECKS**

Handrails and guardrails. . . . . 304.12

Maintenance . . . . . 304.2, 304.10

**DEMOLITION**

Existing remedies . . . . . 102.4

Failure to comply . . . . . 113.3

General . . . . . 113

Order . . . . .	113.2
Salvage materials . . . . .	113.4
<b>DETACHED . . . . .</b>	<b>111.1.5, 202, 306.1.1</b>
<b>DETECTORS</b>	
Smoke . . . . .	704
<b>DETERIORATION</b>	
Components of systems . . . . .	306.1.1
Definition. . . . .	202
Exterior structure . . . . .	304.1.1
Exterior walls . . . . .	304.6
<b>DIRECT</b>	
Egress . . . . .	702.1
<b>DISPOSAL</b>	
Disposal of garbage . . . . .	308.3
Disposal of rubbish . . . . .	308.2
<b>DOOR</b>	
Exit doors . . . . .	702.3
Fire . . . . .	703.2
Hardware . . . . .	304.15
Insect screens . . . . .	304.14
Interior surfaces . . . . .	305.3
Locks . . . . .	304.15, 702.3
Maintenance . . . . .	304.13, 304.15
Weather tight . . . . .	304.13
Window and door frames . . . . .	304.13
<b>DORMITORY (ROOMING HOUSE, HOTEL, MOTEL)</b>	
Locked doors . . . . .	702.3
Privacy . . . . .	503.1, 503.2
<b>DRAFT STOPPING</b>	
Maintenance . . . . .	703.3.1
<b>DRAIN, DRAINAGE</b>	
Basement hatchways . . . . .	304.16
Plumbing connections. . . . .	506
Storm drainage . . . . .	507
<b>DUCT</b>	
Duct systems . . . . .	607
Exhaust duct . . . . .	304.9
<b>DUST</b>	
Process ventilation . . . . .	403.4

**DWELLING**

Cleanliness . . . . . 305.1, 308.1  
Definition. . . . . 202  
Electrical . . . . . 604.1  
Heating facilities . . . . . 602  
Required facilities . . . . . 502

**E**

**EGRESS**

Aisles . . . . . 702.2  
Emergency escape . . . . . 702.4  
General . . . . . 702.1  
Lighting . . . . . 402.2  
Locked doors . . . . . 702.3  
Obstructions prohibited. . . . . 702.1  
Stairs, porches and railings. . . . . 304.10,  
305.4, 305.5, 307.1

**ELECTRIC, ELECTRICAL EQUIPMENT**

Abatement of hazards, fire exposure . . . . . 604.3.2  
Abatement of hazards, water exposure . . . . . 604.3.1  
Condemnation. . . . . 111.1  
Electrical equipment . . . . . 604.3.1.1  
Facilities required . . . . . 604.1  
Hazards. . . . . 604.3  
Installation. . . . . 605.1  
Lighting fixtures. . . . . 605.3  
Receptacles . . . . . 604.3, 605.2  
Responsibility . . . . . 601.2  
Service . . . . . 604.2

**ELEVATOR, ESCALATORS, DUMBWAITERS**

Condemnation. . . . . 111.1  
General . . . . . 606.1  
Maintenance . . . . . 606.1, 606.2

**EMERGENCY**

Emergency escape openings . . . . . 702.4  
Emergency measures. . . . . 112  
Emergency orders. . . . . 112.1

**ENFORCEMENT**

Duties and powers . . . . . 105  
Scope . . . . . 101.2

**EQUIPMENT**

Alternative. . . . . 106.2  
Combustion air . . . . . 603.5  
Condemnation . . . . . 111.1.2, 111.3  
Electrical installation . . . . . 605.1

Emergency order . . . . .	112.1
Energy conservation devices. . . . .	603.6
Installation . . . . .	603.1
Interior structure. . . . .	305.1
Placarding . . . . .	111.7, 111.8
Prohibited use . . . . .	111.8
Responsibility. . . . .	601.2
Safety controls . . . . .	603.4
Scope. . . . .	101.2
Scope, mechanical and electrical . . . . .	601.1
Support, definition . . . . .	202
Unsafe . . . . .	111.1.2
Used . . . . .	106.4

**EXHAUST**

Clothes dryer . . . . .	403.5
Exhaust ducts . . . . .	304.9
Process ventilation. . . . .	403.4

**EXISTING**

Remedies. . . . .	102.4
Scope. . . . .	101.2
Structural members . . . . .	304.1.1, 304.4
Structures . . . . .	101.3

**EXTERIOR**

Decorative features . . . . .	304.8
Exterior structure . . . . .	304
Exterior walls . . . . .	304.6
Painting . . . . .	304.2, 304.6
Rodent harborage . . . . .	302.5, 304.5
Sanitation. . . . .	304.1
Scope. . . . .	301.1
Stair . . . . .	304.10
Street numbers . . . . .	304.3
Unsafe conditions . . . . .	304.1.1
Weather tight . . . . .	304.13

**F**

**FAN**

Exhaust vents . . . . .	302.6
-------------------------	-------

**FEES, EXPENSES, COST**

Closing vacant structures . . . . .	111.2
Demolition . . . . .	113.1, 113.3, 113.4
Extermination. . . . .	309.2, 309.3, 309.4, 309.5
General . . . . .	104.1
Relief from personal liability. . . . .	105.7

**FENCE**

- Accessory . . . . . 302.7
- Maintenance . . . . . 304.2

**FIRE**

- Blocking Maintenance . . . . . 703.3.1

**FIRE DEPARTMENT**

- Connection access. . . . . 704.5.1, 704.5.2
- Connections . . . . . 704.5

**FIRE PROTECTION SYSTEMS**

- Emergency impairments . . . . . 704.3.1
- Equipment . . . . . 704.4, 704.4.1, 704.4.2
- Inspection. . . . . 704.1, 704.1.3, 704.2
- Installation . . . . . 704.1.1
- Maintenance. . . . . 704.1, 704.1.3, 704.2
- Out of service. . . . . 704.3
- Records of maintenance . . . . . 704.2.1
- Required systems . . . . . 704.1.2, 704.2.2
- Smoke alarms . . . . . 704.6
- Smoke detections systems . . . . . 704.6.4
- Termination of service . . . . . 704.4.3
- Testing . . . . . 704.1, 704.1.3, 704.2

**FIRE-RESISTANCE RATINGS**

- Ceilings . . . . . 703.5
- Draft stopping . . . . . 703.3.1
- Fire barriers . . . . . 703.3.3
- Fire blocking . . . . . 703.3.1
- Fire partitions . . . . . 703.3.3
- Fire walls . . . . . 703.3.3
- Maintenance . . . . . 703.3
- Opening protective. . . . . 703.4
- Shafts. . . . . 703.7
- Smoke barriers. . . . . 703.3.2
- Smoke partitions . . . . . 703.3.2
- Unsafe conditions. . . . . 703.2

**FLAMMABLE LIQUID**

- Containers . . . . . 111.1.2

**FLOOR, FLOORING**

- Area for sleeping purposes . . . . . 404.4.1
- Fire-resistance ratings . . . . . 703.1
- Interior surfaces . . . . . 305.1, 305.3
- Space requirements . . . . . 404.4.1, 404.6

**FOOD PREPARATION**

- Cooking equipment . . . . . 403.3
- Sanitary condition. . . . . 305.1, 404.7

Ventilation . . . . . 403.4

**FOUNDATION**

Condemnation . . . . . 111.1.1  
Foundation walls . . . . . 304.5  
Unsafe conditions. . . . . 304.1.1, 305.1.1

**FRAME**

Window and door frames . . . . . 304.13

**G**

**GARBAGE.** . . . . 308

**GAS**

Energy conservation devices . . . . . 603.6  
Exhaust vents. . . . . 302.6

**GLAZING**

Materials . . . . . 304.13.1

**GRADE**

Drainage . . . . . 302.2, 507

**GUARD**

Anchorage and maintenance . . . . . 304.12  
Basement windows. . . . . 304.18.2  
Definition. . . . . 202

**H**

**HABITABLE**

Definition. . . . . 202  
Light . . . . . 402  
Minimum ceiling height . . . . . 404.3  
Minimum room width . . . . . 404.2  
Required plumbing facilities . . . . . 502  
Residential heating facilities . . . . . 602.2, 602.3  
Space requirements . . . . . 404.4.1  
Ventilation. . . . . 403

**HABITABLE SPACE.** . . . . 402.1, 403.1, 404.4.2, 605.2

**HANDRAILS AND GUARDRAILS**

Handrails . . . . . 304.12, 305.5, 307.1  
Stairs and porches . . . . . 304.10

**HARDWARE**

Door hardware . . . . . 304.15, 702.3  
Openable windows . . . . . 304.13.2



**HEAT, HEATING**

Energy conservation devices . . . . .603.6  
Fireplaces . . . . .603.1  
Heating . . . . .603.1  
Mechanical equipment . . . . .603.1  
Required capabilities . . . . . 602  
Residential heating . . . . . 602.2, 602.3  
Supply. . . . .602.3  
Water heating facilities . . . . .505.4  
Water system . . . . . 505

**HEIGHT**

Minimum ceiling height . . . . .404.3

**HISTORIC BUILDING**

**HOTELS, ROOMING HOUSES AND DORMITORY UNITS, MOTELS**

Definition. . . . . 202  
Locked doors . . . . .702.3  
Required facilities . . . . . 502  
Toilet rooms . . . . . 503

**HOUSEKEEPING UNIT**

Definition. . . . . 202

**I**

**IDENTIFICATION**

Code official . . . . . 105.4

**IMMINENT DANGER . . . . 107.5, 112.1, 703.2, B101.2.2**

**INFESTATION**

Condemnation. . . . . 111.1.3  
Definition. . . . . 202  
Insect and rodent . . . . . 302.5, 304.14, 309.1

**INSECTS**

Infestation . . . . . 309.1  
Insect screens. . . . . 304.14  
Pest elimination. . . . . 309

**INSPECTIONS**

General . . . . . 105.2  
Right of entry. . . . . 105.3

**INSPECTOR**

Identification . . . . . 105.4  
Inspections . . . . . 105.2  
Records. . . . . 105.6

**INTENT**

Code . . . . . 101.3

**INTERIOR**

Interior structure . . . . . 305  
Interior surfaces . . . . . 305.3  
Means of egress . . . . . 702  
Sanitation . . . . . 305.1  
Unsafe conditions . . . . . 305.1.1

**J**

**JURISDICTION**

Title . . . . . 101.1

**K**

**KITCHEN**

Electrical outlets required . . . . . 605.2  
Minimum width . . . . . 404.2  
Prohibited use. . . . . 404.4.4  
Room lighting . . . . . 605.3  
Water heating facilities . . . . . 505.4

**L**

**LANDING**

Handrails and guards . . . . . 304.12,  
305.5, 306.1  
Maintenance . . . . . 304.10, 305.4

**LAUNDRY**

Room lighting . . . . . 605.3  
Water-heating facilities . . . . . 505.4

**LAVATORY**

Hotels. . . . . 502.3  
Required facilities . . . . . 502  
Rooming houses . . . . . 502.2  
Sanitary drainage system . . . . . 506  
Water system. . . . . 505  
Water-heating facilities . . . . . 505.4

**LEASE (SELL, RENT)**

Heat supplied. . . . . 602.3  
Salvage materials . . . . . 113.4  
Transfer of ownership . . . . . 111.6

**LIEN**

Closing of vacant structures . . . . . 111.2  
Demolition . . . . . 113.3

Failure to comply . . . . . 113.3

**LIGHT, LIGHTING**

Common halls and stairways. . . . . 402.2, 605.3  
General . . . . . 402  
Habitable rooms. . . . . 402.1  
Kitchen. . . . . 605.3  
Laundry rooms. . . . . 605.3  
Luminaires . . . . . 605.3  
Other spaces . . . . . 402.3  
Responsibility. . . . . 401.2  
Scope. . . . . 101.2  
Toilet rooms . . . . . 605.3

**LIVING ROOM**

Room area . . . . . 404.4.1

**LOAD, LOADING**

Elevators, escalators and dumbwaiters . . . . . 606.1  
Handrails and guardrails . . . . . 304.12, 305.5  
Live load . . . . . 304.4, 305.2  
Stairs and porches. . . . . 304.10, 305.2  
Structural members . . . . . 304.4, 305.2

**M**

**MAINTENANCE**

Required . . . . . 102.2

**MATERIAL**

Alternative . . . . . 106.2  
Salvage . . . . . 113.4  
Used . . . . . 106.4

**MEANS OF EGRESS.** . . . . . 111.1.5, 304.15, 402.2,  
702.1, 702.3, 704.6.1.1

**MECHANICAL**

Installation . . . . . 603.1  
Responsibility. . . . . 601.2  
Scope. . . . . 601.1  
Ventilation, general . . . . . 403  
Ventilation, toilet rooms . . . . . 403.2

**MINIMUM**

Ceiling height . . . . . 404.3  
Room area . . . . . 404.4.1  
Room width . . . . . 404.2

**MODIFICATION**

Approval . . . . . 106.1

**MOTOR VEHICLES**

- Inoperative . . . . . 302.8
- Painting . . . . . 302.8

**N**

**NATURAL**

- Lighting. . . . . 401.3, 402
- Ventilation . . . . . 401.3, 403

**NOTICES AND ORDERS**

- Appeal . . . . . 107.2
- Form. . . . . 111.4.1
- Method of service. . . . . 111.4.2
- Orders . . . . . 107
- Owner, responsible person . . . . . 111.4
- Penalties . . . . . 107.5
- Placarding of structure . . . . . 111.7
- Transfer of ownership . . . . . 111.6
- Unauthorized tampering. . . . . 111.5
- Vacating structure . . . . . 111.2

**NOXIOUS**

- Process ventilation. . . . . 403.4
- Weeds . . . . . 302.4

**NUISANCE**

- Closing of vacant structures. . . . . 111.2

**O**

**OBSTRUCTION**

- Light . . . . . 402.1
- Right of entry . . . . . 105.3

**OCCUPANT**

**OPENABLE**

- Locked doors . . . . . 702.3
- Windows. . . . . 304.13.2, 403.1

**OPENING PROTECTIVES**

- Closers . . . . . 703.8
- Door operation . . . . . 703.4.3
- Hold-open devices . . . . . 703.4.2
- Maintenance. . . . . 703.4
- Signs . . . . . 703.4.1
- Testing . . . . . 703.6

**OPERATOR**

Definition . . . . . 202

**ORDINANCE, RULE**

Applicability . . . . . 102  
Application for appeal. . . . . 107.2

**OUTLET**

Electrical . . . . . 605.2

**OWNER**

Closing of vacant structures . . . . . 111.2  
Definition. . . . . 202  
Demolition. . . . . 113  
Failure to comply . . . . . 113.3  
Insect and rat control . . . . . 302.5, 309.2, 309.4  
Notice . . . . . 111.4, 111.3  
Pest elimination . . . . . 309.2  
Placarding of structure . . . . . 111.7  
Responsibility . . . . . 301.2  
Responsibility, fire safety . . . . . 701.2  
Responsibility, light, ventilation. . . . . 401.2  
Responsibility, mechanical and electrical . . . . . 601.2  
Responsibility, plumbing facilities . . . . . 501.2  
Right of entry . . . . . 105.3  
Rubbish storage . . . . . 308.2.1  
Scope . . . . . 101.2  
Transfer of ownership. . . . . 111.6

**P**

**PASSAGEWAY**

Common hall and stairway . . . . . 402.2  
Interior surfaces . . . . . 305.3  
Toilet rooms, direct access. . . . . 503.1

**PENALTY**

Notices and orders . . . . . 107.5  
Placarding of structure . . . . . 111.7  
Prohibited occupancy . . . . . 111.8  
Removal of placard. . . . . 111.7.1  
Scope . . . . . 101.2  
Violations . . . . . 109.4

**PEST ELIMINATION**

Condemnation . . . . . 111.1  
Definition. . . . . 202  
Insect and rodent control . . . . . 302.5, 304.5,  
304.14, 309.1  
Pest elimination . . . . . 309.1  
Responsibility of owner. . . . . 301.2, 309.2

Responsibility of tenant-occupant . . . . .309.3, 309.4,  
309.5

**PLACARD, POST**

Closing . . . . .111.2  
Condemnation . . . . .111.1  
Demolition. . . . . 113  
Emergency, notice . . . . .112.1  
Notice to owner. . . . . 111.4, 111.3  
Placarding of structure . . . . .111.7  
Prohibited use. . . . .111.8  
Removal . . . . . 111.7.1

**PLUMBING**

Clean and sanitary . . . . .504.1  
Clearance . . . . . 504.2  
Connections . . . . . 505.1  
Contamination. . . . . 505.2  
Employee’s facilities . . . . . 503.3  
Fixtures . . . . . 504.1  
Required facilities . . . . . 502  
Responsibility . . . . . 501.2  
Sanitary drainage system . . . . . 506  
Scope . . . . . 501.1  
Storm drainage . . . . . 507  
Supply . . . . . 505.3  
Water heating facilities . . . . . 505.4

**PORCH**

Handrails. . . . . 304.12  
Structurally sound . . . . . 304.10

**PORTABLE (TEMPORARY)**

Cooking equipment . . . . . 603.1

**PRESSURE**

Water supply. . . . . 505.3

**PRIVATE, PRIVACY**

Bathtub or shower. . . . . 503.1  
Occupancy limitations. . . . . 404.1  
Required plumbing facilities . . . . . 502  
Sewage system. . . . . 506.1  
Water closet and lavatory . . . . . 503.1  
Water system . . . . . 505.1

**PROPERTY, PREMISES**

Cleanliness . . . . . 304.1, 308.1  
Condemnation. . . . . 111  
Definition. . . . . 202  
Demolition . . . . . 113

Emergency measures . . . . .	112
Exterior areas . . . . .	302
Failure to comply . . . . .	113.3
Grading and drainage . . . . .	302.2
Pest elimination, multiple occupancy . . . . .	302.5, 309.4
Pest elimination, single occupancy . . . . .	302.5, 309.3
Responsibility . . . . .	301.2
Scope . . . . .	301.1
Storm drainage . . . . .	507
Vacant structures and land . . . . .	301.3

**PROTECTION**

Basement windows . . . . .	304.17
Fire protection systems . . . . .	704
Signs, marquees and awnings . . . . .	304.9

**PUBLIC**

Cleanliness . . . . .	304.1, 305.1
Egress . . . . .	702.1
Hallway . . . . .	502.3
Sewage system . . . . .	506.1
Toilet facilities . . . . .	502.5, 503
Vacant structures and land . . . . .	301.3
Water system . . . . .	505

**PUBLIC WAY**

Definition . . . . .	202
----------------------	-----

**R**

**RAIN (PREVENTION OF ENTRY INTO BUILDING EXTERIOR ENVELOPE)**

Basement hatchways . . . . .	304.16
Exterior walls . . . . .	304.6
Grading and drainage . . . . .	302.2
Roofs . . . . .	304.7
Window and door frames . . . . .	304.13

**RECORD**

Official records . . . . .	105.6
----------------------------	-------

**REPAIR**

Application of other codes . . . . .	102.3
Chimneys . . . . .	304.11
Demolition . . . . .	113.1
Exterior surfaces . . . . .	304.1
Intent . . . . .	101.3
Maintenance . . . . .	102.2
Signs, marquees and awnings . . . . .	304.9
Stairs and porches . . . . .	304.10
Weather tight . . . . .	304.13

Workmanship . . . . . 102.5

**REPORTS**

Test reports . . . . . 106.3.2

**RESIDENTIAL**

Pest elimination . . . . . 309

Residential heating . . . . . 602.2

Scope . . . . . 101.2

**RESPONSIBILITY**

Fire safety . . . . . 701.2

Garbage disposal . . . . . 308.3

General . . . . . 301.2

Mechanical and electrical . . . . . 601.2

Persons . . . . . 301.1

Pest elimination . . . . . 309

Placarding of structure . . . . . 111.7

Plumbing facilities . . . . . 501.2

Rubbish storage . . . . . 308.2.1

Scope . . . . . 101.2, 301.1

**REVOKE, REMOVE**

Demolition . . . . . 113

Existing remedies . . . . . 102.4

Removal of placard . . . . . 111.7.1

Rubbish removal . . . . . 308.2.1

**RIGHT OF ENTRY**

Duties and powers of code official . . . . . 105.3

Inspections . . . . . 105.2

**RODENTS**

Basement hatchways . . . . . 304.16

Condemnation . . . . . 111

Foundations . . . . . 304.5

Guards for basement windows . . . . . 304.17

Harborage . . . . . 302.5

Insect and rodent control . . . . . 309.1

Pest elimination . . . . . 302.5, 309

**ROOF**

Exterior structure . . . . . 304.1

Roofs . . . . . 304.7

Storm drainage . . . . . 507

**ROOM**

Bedroom and living room . . . . . 404.4

Cooking facilities . . . . . 403.3

Direct access . . . . . 503.2

Habitable . . . . . 402.1



Heating facilities . . . . .	602
Light . . . . .	402
Minimum ceiling heights . . . . .	404.3
Minimum width . . . . .	404.2
Overcrowding . . . . .	404.5
Prohibited use . . . . .	404.4.4
Temperature . . . . .	602.5
Toilet . . . . .	503
Ventilation . . . . .	403

**RUBBISH**

Accumulation . . . . .	308.1
Definition . . . . .	202
Disposal . . . . .	308.2
Garbage facilities . . . . .	308.3.1
Rubbish storage . . . . .	308.2.1

**S**

**SAFETY, SAFE**

Fire safety requirements . . . . .	701, 702, 703, 704
Safety controls . . . . .	603.4

**SANITARY**

Cleanliness . . . . .	304.1, 305.1
Disposal of garbage . . . . .	308.3
Disposal of rubbish . . . . .	308.2
Exterior property areas . . . . .	302.1
Exterior structure . . . . .	304.1
Food preparation . . . . .	404.7
Furnished by occupant . . . . .	302.1
Grease interceptors . . . . .	506.3
Interior surfaces . . . . .	305.3
Plumbing fixtures . . . . .	504.1
Required plumbing facilities . . . . .	502
Scope . . . . .	101.2

**SCREENS**

Insect screens . . . . .	304.14
--------------------------	--------

**SECURITY**

Basement hatchways . . . . .	304.18.3
Building . . . . .	304.18
Doors . . . . .	304.18.1
Vacant structures and land . . . . .	301.3
Windows . . . . .	304.18.2

**SELF-CLOSING SCREEN DOORS**

Insect screens . . . . .	304.14
--------------------------	--------

**SEPARATION**

Fire-resistance ratings . . . . . 703  
Privacy . . . . . 404.1  
Separation of units . . . . . 404.1

**SERVICE**

Electrical . . . . . 604.2  
Method . . . . . 111.4.2  
Notices and orders . . . . . 111.4, 111.3  
Service on occupant . . . . . 111.3

**SEWER**

General . . . . . 506.1  
Maintenance . . . . . 506.2

**SHOWER**

Bathtub or shower . . . . . 502.1  
Rooming houses. . . . . 502.2  
Water system . . . . . 505  
Water-heating facilities . . . . . 505.4

**SIGN**

Fire door signs . . . . . 703.4.1  
Signs, marquees and awnings . . . . . 304.9  
Unauthorized tampering . . . . . 111.5

**SINGLE-FAMILY DWELLING**

Extermination . . . . . 309

**SINK**

Kitchen sink . . . . . 502.1  
Sewage system . . . . . 506  
Water supply. . . . . 505.3

**SIZE**

Efficiency unit . . . . . 404.6  
Habitable room, light. . . . . 402  
Habitable room, ventilation . . . . . 403  
Room area . . . . . 404.4.1

**SMOKE ALARMS**

Group R-1. . . . . 704.6.1.1  
Groups R-2, R-3, R-4 and I-1 . . . . . 704.6.1.2  
Installation near bathrooms . . . . . 704.6.1.4  
Installation near cooking appliances. . . . . 704.6.1.3  
Interconnection . . . . . 704.6.2  
Power source . . . . . 704.6.3  
Testing . . . . . 704.7  
Where required. . . . . 704.6.1

**SPACE**

General, light . . . . . 402  
General, ventilation. . . . . 403  
Occupancy limitations. . . . . 404  
Privacy . . . . . 404.1  
Scope . . . . . 401.1

**STACK**

Smoke. . . . . 304.11

**STAIRS**

Common halls and stairways, light . . . . . 402.2  
Exit facilities . . . . . 305.4  
Exterior property areas . . . . . 302.3  
Handrails. . . . . 304.12, 305.5  
Lighting . . . . . 605.3  
Stairs and porches . . . . . 304.10

**STANDARD**

Referenced . . . . . 102.8

**STOP WORK ORDER**

Authority . . . . . 110.1  
Emergencies. . . . . 110.3  
Failure to comply. . . . . 110.4  
Issuance . . . . . 110.2

**STORAGE**

Food preparation. . . . . 404.7  
Garbage storage facilities . . . . . 308.3  
Rubbish storage facilities . . . . . 308.2.1  
Sanitation . . . . . 308.1

**STRUCTURE**

Accessory structures. . . . . 302.7  
Closing of vacant structures . . . . . 111.2  
Definition. . . . . 202  
Emergency measures. . . . . 112  
General, condemnation. . . . . 113  
General, exterior . . . . . 304.1  
General, interior structure . . . . . 305.1  
Placarding of structure . . . . . 111.7  
Scope . . . . . 301.1  
Structural members. . . . . 304.4, 305.2  
Vacant structures and land . . . . . 301.3

**SUPPLY**

Combustion air . . . . . 603.5  
Public water system . . . . . 505.1  
Water supply. . . . . 505.3  
Water system . . . . . 505

Water-heating facilities . . . . . 505.4

**SURFACE**

Exterior surfaces . . . . . 304.2, 304.6  
Interior surfaces . . . . . 305.3

**SWIMMING**

Enclosure . . . . . 303.2  
Safety covers . . . . . 303.2  
Swimming pools . . . . . 303.1

**T**

**TEMPERATURE**

Nonresidential structures . . . . . 602.4  
Residential buildings . . . . . 602.2  
Water-heating facilities . . . . . 505.4

**TENANT**

Scope . . . . . 101.2

**TEST, TESTING**

Agency . . . . . 106.3.1  
Methods . . . . . 106.3.1  
Reports . . . . . 106.3.2  
Required . . . . . 106.3

**TOXIC**

Process ventilation . . . . . 403.4

**TRASH**

Rubbish and garbage . . . . . 308

**U**

**UNOBSTRUCTED**

Access to public way . . . . . 702.1  
General, egress . . . . . 702.1

**UNSAFE STRUCTURES AND EQUIPMENT**

Abatement methods . . . . . 111.9  
Dangerous structure or premises . . . . . 111.1.5  
Equipment . . . . . 111.1.2  
Existing remedies . . . . . 102.4  
General, condemnation . . . . . 111, 113  
General, demolition . . . . . 113  
Notices and orders . . . . . 107, 111.3  
Record . . . . . 111.3  
Structures . . . . . 111.1.1

**USE**

- Application of other codes . . . . . 102.3
- General, demolition . . . . . 113

**UTILITIES**

- Authority to disconnect . . . . . 111.2.1

**V**

**VACANT**

- Abatement methods. . . . . 111.9
- Authority to disconnect service utilities . . . . 111.2.1
- Closing of vacant structures . . . . . 111.2
- Emergency measure . . . . . 112
- Method of service . . . . . 111.4.2, 111.3
- Notice to owner or to  
person responsible. . . . . 107, 111.3
- Placarding of structure. . . . . 111.7
- Record . . . . . 111.3
- Vacant structures and land . . . . . 301.3

**VAPOR**

- Exhaust vents . . . . . 302.6

**VEHICLES**

- Inoperative . . . . . 302.8
- Painting . . . . . 302.8

**VENT**

- Exhaust vents. . . . . 302.6
- Flue . . . . . 603.2
- Plumbing hazard . . . . . 504.3

**VENTILATION**

- Clothes dryer exhaust . . . . . 403.5
- Combustion air . . . . . 603.5
- Definition . . . . . 202
- General, ventilation . . . . . 403
- Habitable rooms . . . . . 403.1
- Process ventilation. . . . . 403.4
- Recirculation . . . . . 403.2, 403.4
- Toilet rooms . . . . . 403.2

**VERMIN**

- Condemnation . . . . . 111
- Insect and rodent control . . . . . 302.5, 309

**VERTICAL SHAFTS**

- Required enclosure . . . . . 703.7

**VIOLATION**

Condemnation . . . . . 111  
Enforcement. . . . . 109.2  
General . . . . . 109  
Notice. . . . . 107, 111.3  
Placarding of structure . . . . . 111.7  
Prosecution . . . . . 109.3  
Separate offenses . . . . . 109.4  
Strict liability offense . . . . . 109.3, 202  
Transfer of ownership . . . . . 111.6

**W**

**WALK**

Sidewalks . . . . . 302.3

**WALL**

Accessory structures . . . . . 302.7  
Exterior surfaces . . . . . 304.2, 304.6  
Exterior walls . . . . . 304.6  
Foundation walls . . . . . 304.5  
General, fire-resistance rating . . . . . 703.1  
Interior surfaces . . . . . 305.3  
Outlets required . . . . . 605.2  
Temperature measurement . . . . . 602.5

**WASTE**

Disposal of garbage . . . . . 308.3  
Disposal of rubbish. . . . . 308.2  
Garbage storage facilities . . . . . 308.3.1

**WATER**

Basement hatchways . . . . . 304.16  
Connections . . . . . 506.1  
Contamination . . . . . 505.2  
General, sewage . . . . . 506  
General, storm drainage. . . . . 507  
General, water system . . . . . 505  
Heating . . . . . 505.4  
Hotels . . . . . 502.3  
Kitchen sink . . . . . 502.1  
Nonpotable water reuse . . . . . 505.5, 505.5.1  
Required facilities . . . . . 502  
Rooming houses. . . . . 502.2  
Supply. . . . . 505.3  
System . . . . . 505  
Toilet rooms . . . . . 503  
Water-heating facilities . . . . . 505.4

**WEATHER, CLIMATE**

Heating facilities . . . . . 602

**WEEDS**

Noxious weeds . . . . .302.4

**WIDTH**

Minimum room width . . . . .404.2

**WINDOW**

Emergency escape . . . . .702.4  
 Glazing . . . . .304.13.1  
 Guards for basement windows . . . . .304.17  
 Habitable rooms . . . . .402.1  
 Insect screens . . . . .304.14  
 Interior surface . . . . .305.3  
 Light . . . . .402  
 Openable windows . . . . .304.13.2  
 Toilet rooms . . . . .403.2  
 Ventilation. . . . .403  
 Weather tight . . . . .304.13  
 Window and door frames . . . . .304.13

**WORKMANSHIP**

General . . . . .102.5

**Y**

**YARD** . . . . .202, 507.1

AN ORDINANCE

BY \_\_\_\_\_

NO. \_\_\_\_\_

TO PROVIDE BY MUTUAL AGREEMENT FOR THE ADJUSTMENT OF THE BOUNDARY LINE BETWEEN THE CITIES OF OAKWOOD AND KETTERING, OHIO.

WHEREAS, the City of Kettering and the City of Oakwood are mutually agreeable to the adjustment of their corporate boundaries; and

WHEREAS, the existing and proposed boundary lines have been duly and accurately surveyed and descriptions prepared as fully set forth in Exhibit A, attached hereto and incorporated herein;

NOW, THEREFORE, BE IT ORDAINED BY THE COUNCIL OF THE CITY OF OAKWOOD, OHIO:

SECTION I.

Having reviewed the proposed corporate boundary line adjustment, this Council finds the adjustment to be in the best interest of city, and therefore this Council hereby accepts and assents to the adjustment of the corporate boundary line of the City of Oakwood as depicted and described on Exhibit A.

SECTION II.

This Council determines and finds that the change in the boundary line separating the municipal corporations of Oakwood and Kettering does not involve the transfer of territory inhabited by more than five (5) voters from one to the other or from each to the other.

SECTION III.

Upon its adoption, the Clerk of Council is directed to transmit a certified copy of this Ordinance to the Board of County Commissioners of Montgomery County, Ohio, and further request the Board of County Commissioners to pass a resolution approving the change of boundaries and to make such adjustments of funds, unpaid taxes, claims, indebtedness, and other fiscal matters as the Board of County Commissioners determines to be proper.

SECTION IV. This Council finds and determines that all formal actions of this Council concerning and relating to the adoption of this Ordinance were taken in an open meeting of this Council and that all deliberations of this Council and of any committees that resulted in those formal actions were in meetings open to the public in compliance with the law.

SECTION V.

This ordinance shall be and remain in force from and after the earliest period allowed by law.

PASSED BY COUNCIL, this \_\_\_\_ day of \_\_\_\_\_, 2022.

\_\_\_\_\_  
Mayor William D. Duncan

ATTEST:

\_\_\_\_\_  
Clerk of Council

TO THE CLERK:

Please publish one (1) time in the following summary form:



LEGAL NOTICE

Ordinance No. \_\_\_\_\_ of the Council of the City of Oakwood, Ohio, was passed on the \_\_\_\_\_ day of \_\_\_\_\_, 2022. Said Ordinance was adopted to adjust the corporate boundary between the Cities of Oakwood and Kettering by mutual agreement.

LORI STACEL, CLERK OF COUNCIL

\_\_\_\_\_  
City Attorney Robert F. Jacques

CERTIFICATE OF PUBLICATION

I, Lori Stacel, Clerk of the Council of the City of Oakwood, State of Ohio, do hereby certify that the foregoing summary of Ordinance No. \_\_\_\_\_ was duly published in the Oakwood Register, a newspaper of general circulation in the City of Oakwood, and that said publication occurred on the following date:

\_\_\_\_\_  
(Date)

\_\_\_\_\_  
Lori Stacel, Clerk of Council

**CORPORATION LINE ADJUSTMENT  
KETTERING/OAKWOOD  
DOROTHY LANE AREA  
SECTION 35, TOWN 2, RANGE 6 M.Rs.  
MONTGOMERY COUNTY, OHIO  
DECEMBER 2021**

REFERENCE MONTGOMERY  
COUNTY ENGINEER'S OFFICE  
RECORD OF LAND SURVEYS  
VOLUME 21-0417

PARCEL ONE  
LOT # 2869  
3.633 ACRE TRACT  
(TAX PARCEL ID #  
Q71 01102 0002)

PARCEL THREE  
PART LOT # 2871  
1.751 ACRE TRACT  
(TAX PARCEL ID #  
Q71 01102 0003)

PARCEL FOUR  
4.610 ACRE TRACT  
(TAX PARCEL ID #  
N64 03410 0002)

**TOTAL AREA  
TO OAKWOOD  
0.421 AC.**

SECTION 36  
SECTION 35

EX. OAKWOOD CORP.  
LINE PER P.B. "R", PG. 96  
EX. KETTERING CORP.  
LINE PER P.B. "D", PG. 25

(HISTORICAL  
TAX PARCEL ID  
# N64 03410 0003)

Per P.B. 70, Pg. 77

**DOROTHY LANE**

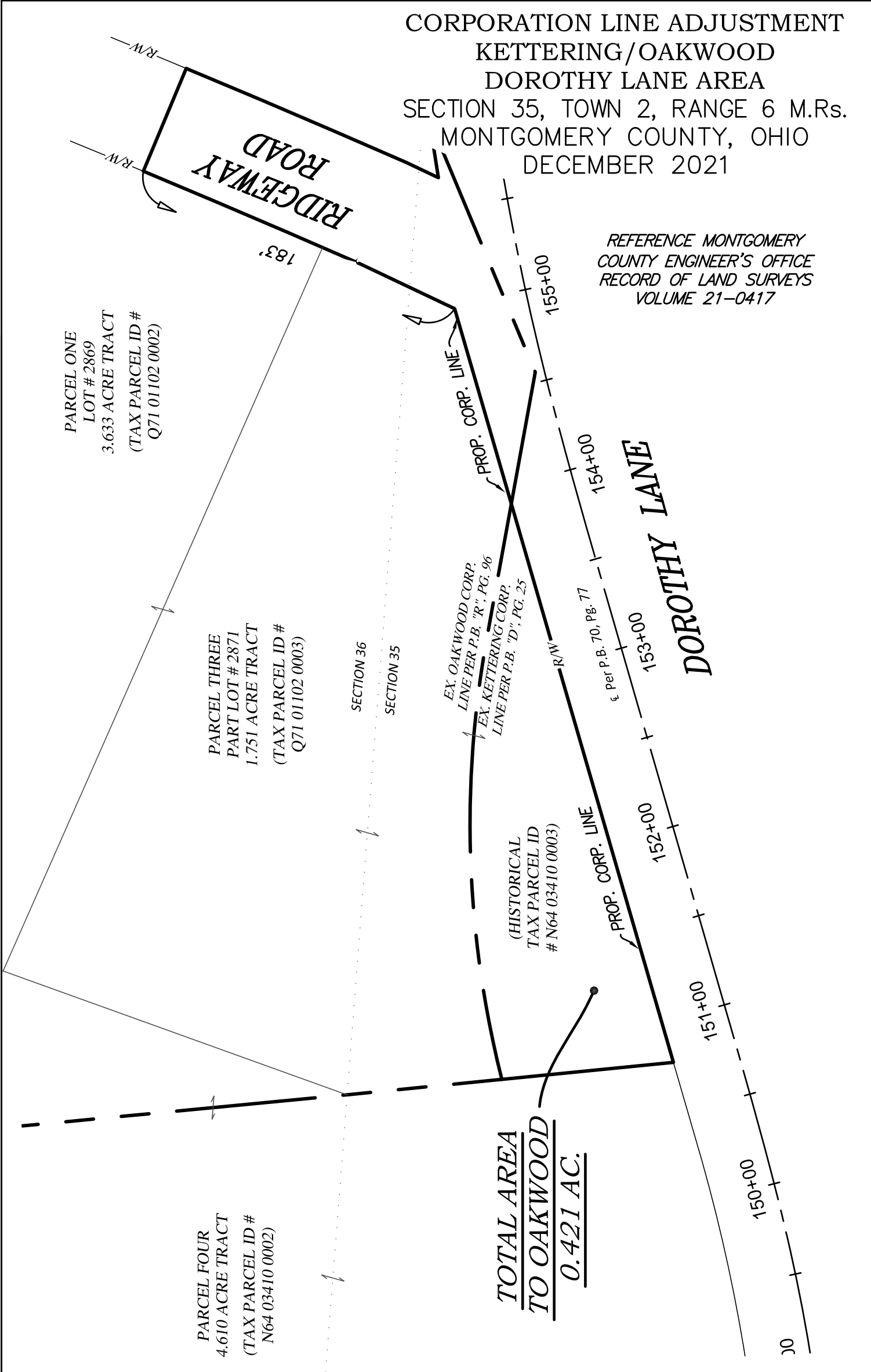

PREPARED BY:  
**CITY OF KETTERING**  
3600 Shroyer Road  
Kettering, OH 45429  
p 937.296.2436 f 937.296.3242  
www.ketteringoh.org

**CORPORATION LINE ADJUSTMENT  
KETTERING/OAKWOOD  
DOROTHY LANE EXHIBIT**

0 30 60  
  
HORZ. SCALE  
IN FEET (1"=60')





## CITY OF KETTERING

ENGINEERING DEPARTMENT

**DESCRIPTION FOR NEW CORPORATION LINE  
BETWEEN CITIES OF KETTERING AND OAKWOOD  
SECTION 35, TOWN 2, RANGE 6 M.Rs.  
DOROTHY LANE AREA  
December 2021**

Situate in Section 35, Town 2, Range 6 M.Rs., Cities of Kettering and Oakwood, Montgomery County, Ohio, and being the new corporation line between the Cities of Kettering and Oakwood, more particularly described as follows:

**Beginning** at an angle point on the existing corporation line between the Cities of Kettering and Oakwood, said point being the southwest corner of Part Lot Number 2871 of the revised and consecutive Lot Numbers on the Plat of the City of Oakwood;

**thence** in an easterly direction along said existing corporation line, also being the south line of said Part Lot Number 2871, to the point of intersection between the existing corporation line and the north right-of-way line of Dorothy Lane;

**thence** along the new corporation line between the Cities of Kettering and Oakwood the following two (2) courses:

1. In a westerly direction along the north right-of-way line of Dorothy Lane, to the southwest corner of historical tax parcel ID #N64 03410 0003;
2. In a northerly direction along the west line of historical tax parcel ID #N64 03410 0003, to the point of beginning.

This corporation line adjustment results in 0.421 acres of land being removed from the City of Kettering's city limits and added to the City of Oakwood's city limits.

Reference Montgomery County Engineer's Record of Land Surveys, Volume 21-0417.

**Prepared by the City of Kettering Engineering Department without a field survey.**

CORPORATION LINE ADJUSTMENT  
 KETTERING/OAKWOOD  
 FAIRMONT AVENUE AREA  
 SECTION 36, TOWN 2, RANGE 6 M.Rs.  
 MONTGOMERY COUNTY, OHIO  
 DECEMBER 2021

REFERENCE MONTGOMERY  
 COUNTY ENGINEER'S OFFICE  
 RECORD OF LAND SURVEYS  
 VOLUME 21-0417

TOTAL AREA  
TO OAKWOOD  
0.113 AC.

2.904 ACRE TRACT  
 LOT # 2867  
 (TAX PARCEL ID #  
 Q71 01103 0017)

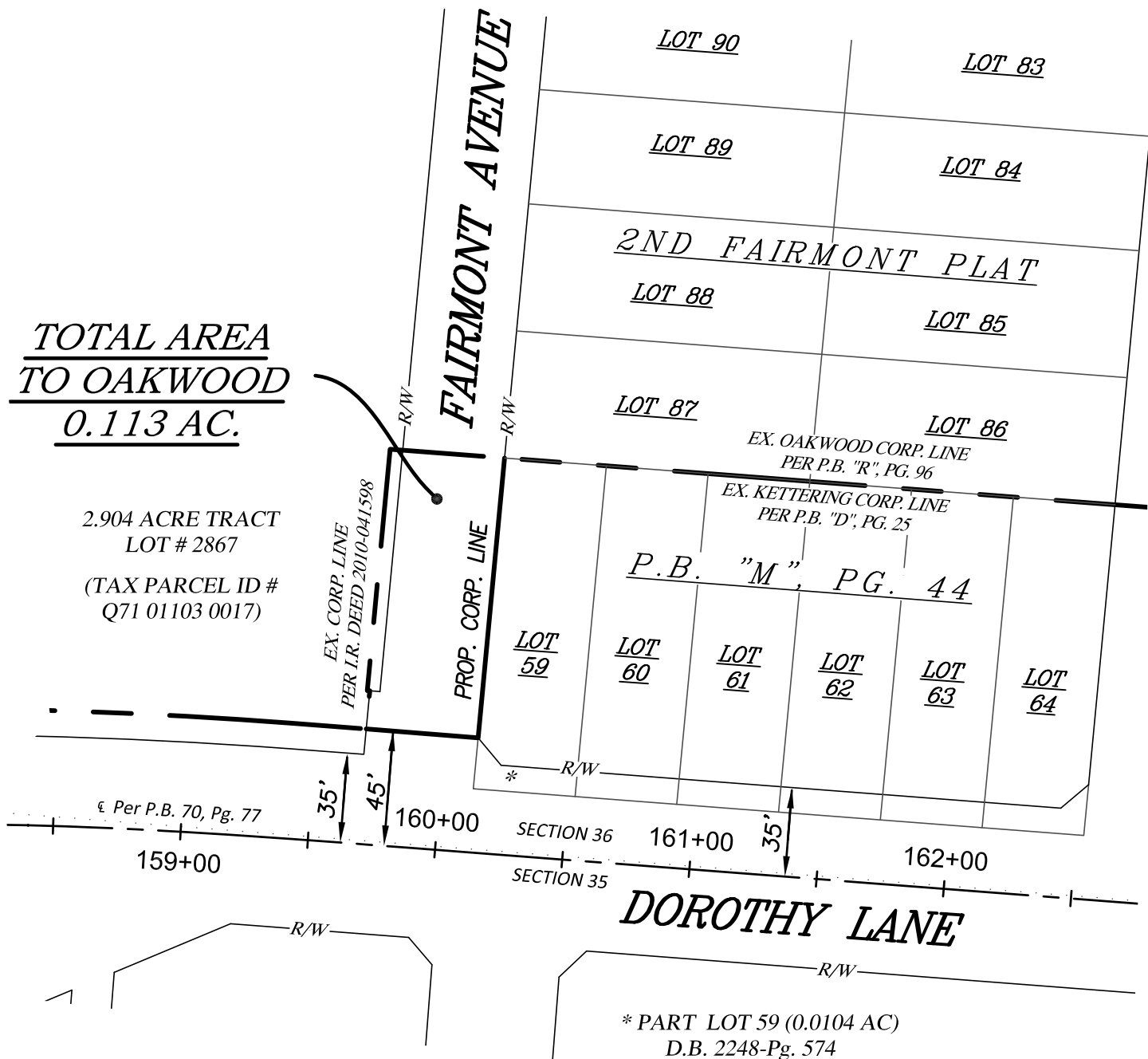

PREPARED BY:  
 CITY OF KETTERING  
 3600 Shroyer Road  
 Kettering, OH 45429  
 p 937.296.2436 f 937.296.3242  
 www.ketteringoh.org

CORPORATION LINE ADJUSTMENT  
 KETTERING/OAKWOOD  
 FAIRMONT AVENUE EXHIBIT

0 30 60  
 HORZ. SCALE  
 IN FEET (1"=60')





## CITY OF KETTERING

ENGINEERING DEPARTMENT

**DESCRIPTION FOR NEW CORPORATION LINE  
BETWEEN CITIES OF KETTERING AND OAKWOOD  
SECTION 36, TOWN 2, RANGE 6 M.Rs.  
FAIRMONT AVENUE AREA  
December 2021**

Situate in Section 36, Town 2, Range 6 M.Rs., Cities of Kettering and Oakwood, Montgomery County, Ohio, and being the new corporation line between the Cities of Kettering and Oakwood, more particularly described as follows:

**Beginning** on the existing corporation line between the Cities of Kettering and Oakwood at the northwest corner of Lot 59 of 2<sup>nd</sup> Fairmont Plat, as recorded in Plat Book "M", Page 44, of the Plat Records of Montgomery County;

**thence** along the new corporation line between the Cities of Kettering and Oakwood the following two (2) courses:

1. In a southerly direction along the east right-of-way line of Fairmont Avenue, to the northwest corner of a 0.0104 acre tract conveyed to the City of Kettering per Deed Book 2248, Page 574, said point be 45.00 feet north of the monument centerline of Dorothy Lane per Plat Book 70, Page 77;
2. In a westerly direction, being 45.00 feet north of and parallel to the monument centerline of Dorothy Lane, to a point on the existing corporation line;

**thence** in a northerly direction along the existing corporation line as described in I.R. Deed 2010-041598, to a point;

**thence** in an easterly direction along the existing corporation line to the point of beginning.

This corporation line adjustment results in 0.113 acres of land being removed from the City of Kettering's city limits and added to the City of Oakwood's city limits.

Reference Montgomery County Engineer's Record of Land Surveys, Volume 21-0417.

**Prepared by the City of Kettering Engineering Department without a field survey.**

CORPORATION LINE ADJUSTMENT  
 KETTERING/OAKWOOD  
 RIDGEWAY ROAD AREA

SECTION 35 & 36, TOWN 2, RANGE 6 M.Rs.  
 MONTGOMERY COUNTY, OHIO  
 DECEMBER 2021

REFERENCE MONTGOMERY  
 COUNTY ENGINEER'S OFFICE  
 RECORD OF LAND SURVEYS  
 VOLUME 21-0417

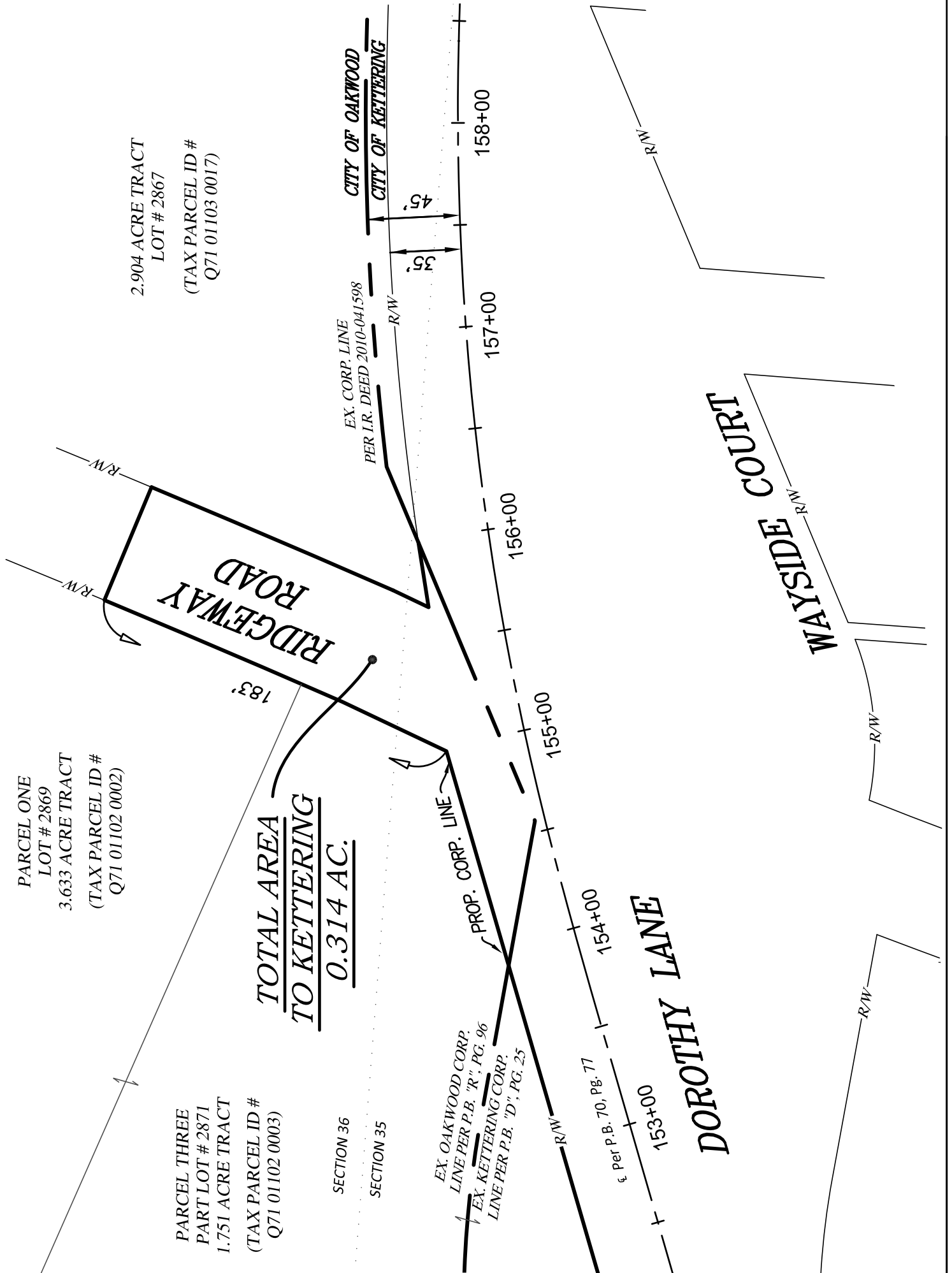

PREPARED BY:  
 CITY OF KETTERING  
 3600 Shroyer Road  
 Kettering, OH 45429  
 p 937.296.2436 f 937.296.3242  
 www.ketteringoh.org

CORPORATION LINE ADJUSTMENT  
 KETTERING/OAKWOOD  
 RIDGEWAY ROAD EXHIBIT

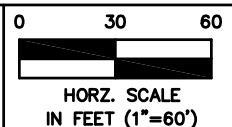



## CITY OF KETTERING

ENGINEERING DEPARTMENT

**DESCRIPTION FOR NEW CORPORATION LINE  
BETWEEN CITIES OF KETTERING AND OAKWOOD  
SECTION 35 & 36, TOWN 2, RANGE 6 M.Rs.  
RIDGEWAY ROAD AREA  
December 2021**

Situate in Section 35 & 36, Town 2, Range 6 M.Rs., Cities of Kettering and Oakwood, Montgomery County, Ohio, and being the new corporation line between the Cities of Kettering and Oakwood, more particularly described as follows:

**Beginning** at the point of intersection of the existing corporation line between the Cities of Kettering and Oakwood with the north right-of-way line of Dorothy Lane, said intersection point being located east of Ridgeway Road;

**thence** in a southwesterly direction along said existing corporation line, said line being within the right-of-way of Dorothy Lane, to a point;

**thence** in a northwesterly direction along said existing corporation line to the point of intersection of the existing corporation line with the north right-of-way line of Dorothy Lane (west of Ridgeway Road);

**thence** along the new corporation line between the Cities of Kettering and Oakwood the following five (5) courses:

1. In a easterly direction along the north right-of-way line of Dorothy Lane, to the west right-of-way line of Ridgeway Road;
2. In a northerly direction along the west right-of-way line of Ridgeway Road for approximately 183 feet, to a point;
3. In a easterly direction to the east right-of-way line of Ridgeway Road;
4. In a southerly direction along the east right-of-way line of Ridgeway Road, to the north right-of-way line of Dorothy Lane;
5. In a easterly direction along the north right-of-way line of Dorothy Lane, to the point of beginning.

This corporation line adjustment results in 0.314 acres of land being removed from the City of Oakwood's city limits and added to the City of Kettering's city limits.

Reference Montgomery County Engineer's Record of Land Surveys, Volume 21-0417.

**Prepared by the City of Kettering Engineering Department without a field survey.**

A RESOLUTION

BY \_\_\_\_\_

NO. \_\_\_\_\_

DECLARING THE NECESSITY OF IMPROVING CERTAIN STREETS  
BETWEEN CERTAIN TERMINI IN THE CITY OF OAKWOOD, OHIO,  
BY LIGHTING THE SAME WITH ELECTRICITY.

BE IT RESOLVED BY THE COUNCIL OF THE CITY OF OAKWOOD, MONTGOMERY  
COUNTY, OHIO:

SECTION I.

That it is necessary to improve the following streets in the City of Oakwood, Ohio:

That street listing is set forth in Exhibit A which is attached to and made a part of this Resolution by such physical attachment as well as by the doctrine of incorporation by reference.

SECTION II.

That said streets shall be improved as shown on the plans and specifications hereinafter referred to and now on file in the office of the Clerk of Council, which are made a part hereof, by lighting the same with electricity for a period from January 1, 2023 through December 31, 2023.

SECTION III.

It is hereby determined and declared that said improvement is conducive to the public health, convenience and welfare of said City and the inhabitants thereof. It is further determined that such streets are so situated in relation to each other that in order to complete the improvement thereof in the most practical and economical manner, they should be improved at the same time, with the same kind of materials, and in the same manner.

SECTION IV.

That the plans, specifications, estimate of cost and profiles of the proposed improvements, heretofore prepared and now on file in the office of the Clerk of Council, are hereby approved.

SECTION V.

That the whole cost of said improvement, less one-fiftieth thereof and the costs of street lighting in intersections, shall be assessed in proportion to the benefits which may result from the improvement upon the following described lots and lands, to wit: all lots and lands bounding and abutting upon the proposed improvement between the termini aforesaid, which said lots and lands are hereby determined to be specially benefited by said improvement. The cost of said improvement shall include the cost of preliminary and other surveys, plans, specifications, profiles and estimates and of printing, serving and publishing notices, resolutions, and ordinances, the amount of damages resulting from the improvement assessed in favor of any owner of land affected by the improvement and the interest thereon, the costs incurred in connection with the preparation, levy and collection of the special assessments, the cost of purchasing, appropriating and otherwise acquiring therefore any required real estate or interest therein, expenses of legal services including obtaining an approving legal opinion, cost of labor and material and interest on bonds and notes issued in anticipation of the levy and collection of the special assessments together with all other necessary expenditures.

SECTION VI.

That the City Manager be and he is hereby authorized and directed to prepare and file or cause to be prepared and filed in the office of the Clerk of Council the estimated assessments of the cost of the improvement described in this Resolution. Such estimated assessments shall be based upon the estimate of cost of said improvement now on file in the office of the Clerk of Council and shall be prepared pursuant to the provisions of this Resolution. When such estimated assessments have been so filed, said Clerk of Council shall cause notice of the adoption of this Resolution and filing of said estimated assessments to be given to owners of all lots and lands to be assessed as proved in Section 727.14 of the Revised Code.



SECTION VII.

That the assessments to be levied shall be paid in one annual installment; provided that the owner of any property assessed may, at his option, pay such assessment in cash within thirty days after passage of the assessing ordinance.

SECTION VIII.

That the bonds of the city shall not be issued in anticipation of the collection of assessments by installments.

SECTION IX.

That it is hereby found and determined that all formal actions of this Council concerning and relating to the passage of this Resolution were adopted in an open meeting of this Council, and that all deliberations of this Council and of any of its committees that resulted in such formal actions, were in meetings open to the public, in compliance with all legal requirements including Section 121.22 of the Ohio Revised Code.

ADOPTED BY COUNCIL this            day March, 2022 .

\_\_\_\_\_  
Mayor William D. Duncan

ATTEST:

\_\_\_\_\_  
Clerk of Council

TO THE CLERK:

Publish the foregoing Resolution in the summary form set forth below.

\_\_\_\_\_  
City Attorney Robert F. Jacques

**LEGAL NOTICE**

Resolution No. \_\_\_\_\_ of the Council of the City of Oakwood, Ohio entitled “DECLARING THE NECESSITY OF IMPROVING CERTAIN STREETS BETWEEN CERTAIN TERMINI IN THE CITY OF OAKWOOD, OHIO, BY LIGHTING THE SAME WITH ELECTRICITY,” was passed the .

\_\_\_\_\_  
Lori Stacel  
CLERK OF COUNCIL

CERTIFICATION OF PUBLICATION

I, Lori Stacel, Clerk of Council of the City of Oakwood, State of Ohio, do hereby certify that the foregoing summary of the foregoing Resolution was duly published in the Oakwood Register, a newspaper of general circulation in said City of Oakwood, and the said publication occurred on the following date:

\_\_\_\_\_  
Lori Stacel  
CLERK OF COUNCIL

## EXHIBIT A

STREET	FROM	TO
ABERDEEN AVENUE	Far Hills Avenue	Shroyer Road
ACACIA DRIVE	Irving Avenue	Schantz Avenue
ACORN DRIVE	Part Lot 2697	Shroyer Road
ALPINE LANE (North Side)	Hillview Avenue	Fairmont Avenue
ASCENT CIRCLE	Pointe Oakwood Way	Old River Trail
ASHRIDGE ROAD	Far Hills Avenue	Devereux Avenue
BEVERLY PLACE	Far Hills Avenue	Acorn Drive
BRIAR HILL ROAD	Park Avenue	Part Lot 93
BROAD BOULEVARD	Shroyer Road	E. Corporation Line
CATON DRIVE	Volusia Avenue	Schantz Avenue
CLARANNA AVENUE	Far Hills Avenue	Shroyer Road
COLLINGWOOD AVENUE	Schantz Avenue	Acorn Drive
COOLIDGE DRIVE	Park Road	Peach Orchard Road
CORONA AVENUE	Far Hills Avenue	Shroyer Road
DEEP HOLLOW ROAD	Ridgeway Road	Oak Knoll Drive
DELAINE AVENUE	Acorn Drive	S. Corporation Line
DELL PARK AVENUE	Far Hills Avenue	Fairmont Avenue
DELLWOOD AVENUE	Far Hills Avenue	Acorn Drive
DEVEREUX DRIVE	Raleigh Road	Forrer Road
DIXON AVENUE (E. & W.)	Runnymede Road	Acorn Drive
EAST DRIVE	Far Hills Avenue	E. Corporation Line
FAIRMONT AVENUE	Alpine Lane	S. Corporation Line
FAIRFOREST CIRCLE	Ridgeway Road	Westerly Terminus
FAR HILLS AVENUE	N. Corporation Line	S. Corporation Line
FORRER BOULEVARD	Far Hills Avenue	E. Corporation Line
FORRER ROAD	Far Hills Avenue	Ridgeway Road
GARDEN AVENUE	Patterson Road	Lookout Drive
GLENDORA AVENUE	Lookout Drive	N. Corporation Line
GRANDON ROAD	Far Hills Avenue	Ridgeway Road
GREENMOUNT BOULEVARD	Far Hills Avenue	Shroyer Road
HADLEY AVENUE (E.)	Far Hills Avenue	Shroyer Road
HADLEY ROAD (W.)	Far Hills Avenue	Ridgeway Road
HARMAN AVENUE	Far Hills Avenue, N. Term.	Far Hills Ave., S. Term.
HARMAN BOULEVARD	Shafor Boulevard	Acorn Drive
HARMAN TERRACE	Harman Avenue	Alley North of Dixon
HATHAWAY ROAD	Part Lot 2697	S. Corporation Line
HAYER ROAD	Rubicon Road	Kramer Road
HILLTOP AVENUE	Far Hills Avenue	Fairmont Avenue
HILLVIEW AVENUE	Alpine Lane	S. Corporation Line
IRVING AVENUE	Oakwood Avenue	E. Corporation Line
IVANHOE AVENUE	E. Thruston Boulevard	Collingwood Avenue
KATHERINE STREET	Oakwood Avenue	Runnymede Road
KATHERINE TERRACE	Runnymede Road	Westerly Terminus
KRAMER ROAD	Schantz Avenue, W.	W. Corporation Line
LEDGES TRAIL	Pointe Oakwood Way	West Terminus
LITTLE WOODS ROAD	Runnymede Road	East Terminus
LONSDALE AVENUE	Far Hills Avenue	Shroyer Road
LOOKOUT DRIVE	E. Thruston Boulevard	Schantz Avenue
LOOKOUT RIDGE	Lookout Drive	Northeasterly Term.
MAHRT AVENUE	Irving Avenue	Schantz Avenue
MAYSFIELD ROAD	Schantz Avenue, W.	Southview Road
MONTERAY AVENUE (E.)	Far Hills Avenue	Shroyer Road
MONTERAY ROAD (W.)	Far Hills Avenue	Coolidge Drive
NORTHVIEW ROAD	Rubicon Road	Kramer Road
OAK FOREST DRIVE	Hathaway Road	Acorn Drive

STREET	FROM	TO
OAK KNOLL DRIVE	Far Hills Avenue	W. Corporation Line
OAKMEAD PLACE	Runnymede Road	Easterly Terminus
OAKWOOD AVENUE	Irving Avenue	Ridgeway Road
OLD RIVER TRAIL	Far Hills Avenue	Westerly Terminus
ORCHARD DRIVE	Far Hills Avenue	Shroyer Road
ORLANDO TERRACE	Mahrt Avenue	Acacia Drive
PARK AVENUE	Far Hills Avenue	Oakwood Avenue
PARK ROAD	Far Hills Avenue	W. Corporation Line
PATTERSON ROAD	Far Hills Avenue	E. Corporation Line
PEACH ORCHARD AVENUE (E.)	Far Hills Avenue	Shroyer Road
PEACH ORCHARD ROAD (W.)	Far Hills Avenue	Ridgeway Road
POINTE OAKWOOD WAY	Old River Trail	Southerly Terminus
RALEIGH ROAD	Harman Avenue	Ridgeway Road
RIDGEWAY ROAD	Harman Avenue	S. Corporation Line
RIDGEWOOD AVENUE	Oakwood Avenue	Schantz Avenue
ROANOKE AVENUE	Alpine Lane	S. Corporation Line
RUBICON ROAD	Springhouse Road	Thruston Boulevard
RUNNYMEDE LANE	Runnymede Road	Westerly Terminus
RUNNYMEDE ROAD	Thruston Boulevard	S. Corporation Line
SCHANTZ AVENUE (E.)	Far Hills Avenue	Forrer Boulevard
SCHANTZ AVENUE (W.)	Far Hills Avenue	W. Corporation Line
SCHENCK AVENUE	Oakwood Avenue	Schantz Avenue
SHAFOR BOULEVARD	Irving Avenue	S. Corporation Line
SHAFOR CIRCLE	Shafor Boulevard	Lots 3737 & 3738
SHROYER ROAD	N. Corporation Line	S. Corporation Line
SORRENTO AVENUE	E. Schantz Avenue	N. Corporation Line
SOUTHVIEW ROAD	Thruston Boulevard	Kramer Road
SOUTHWOOD LANE (E. & W.)	Grandon Road	Park Road
SPIREA DRIVE	Far Hills Avenue	Acorn Drive
SPRINGGROVE AVENUE	Schenck Avenue	N. Corporation Line
SPRINGHOUSE ROAD	Oakwood Avenue	Far Hills Avenue
SUGAR CAMP CIRCLE	Schantz Avenue, West	Schantz Avenue, West
SWEETWOOD LANE	Runnymede Road	W. Corporation Line
TALBOTT COURT	Runnymede Road	Southerly Terminus
TELFORD AVENUE	Far Hills Avenue	Shroyer Road
THORNHILL ROAD	Oakwood Avenue	Runnymede Road
THRUSTON BOULEVARD (E.)	Far Hills Avenue	Easterly Terminus
THRUSTON BOULEVARD (W.)	Far Hills Avenue	W. Corporation Line
TRIANGLE AVENUE	Far Hills Avenue	Shroyer Road
VOLUSIA AVENUE	Far Hills Avenue	Mahrt Avenue
WALNUT LANE	Oakwood Avenue	Lots 2723 & 2724
WALNUT SPRINGS DRIVE	Runnymede Road	W. Corporation Line
WILTSHIRE BOULEVARD	Far Hills Avenue	Shroyer Road
WISTERIA DRIVE	Far Hills Avenue	Acorn Drive
WONDERLY AVENUE	Far Hills Avenue	Shroyer Road
WOODBURN AVENUE	Schantz Avenue	Shafor Boulevard
WOODS ROAD	Patterson Road	Thruston Boulevard
WOODSTOCK DRIVE	Raleigh Road	Forrer Road
WOODVIEW DRIVE	Thruston Boulevard, E.	Collingwood Avenue

AN ORDINANCE

BY: \_\_\_\_\_

NO. \_\_\_\_\_

DETERMINING TO PROCEED WITH THE IMPROVEMENT OF CERTAIN STREETS BETWEEN CERTAIN TERMINI IN THE CITY OF OAKWOOD, OHIO, BY LIGHTING THE SAME WITH ELECTRICITY.

BE IT ORDAINED BY THE COUNCIL OF THE CITY OF OAKWOOD, MONTGOMERY COUNTY, OHIO:

SECTION I.

That it is hereby determined to proceed with the improvement in the City of Oakwood of the streets designated, between certain termini set forth, in Resolution No. \_\_\_\_\_ adopted on the 7<sup>th</sup> day of March, 2022.

SECTION II.

That said improvement shall be made in accordance with the provisions of Resolution No. \_\_\_\_\_ adopted on the 7<sup>th</sup> day of March, 2022, and with the plans, specifications, estimate of cost and profiles heretofore approved and now on file in the office of the Clerk of Council by lighting said streets with electricity for a period from January 1, 2023 through December 31, 2023.

SECTION III.

That Council hereby finds and determines that no claims for damages resulting from said improvement have been filed.

SECTION IV.

That portion of the cost provided in that above-mentioned Resolution of Necessity to be assessed shall be assessed in the manner and the number of installments provided in said Resolution and on the lots and lands described therein.

SECTION V.

That the estimated assessments heretofore prepared and filed in the office of the Clerk of Council be and the same are hereby adopted.

SECTION VI.

The Clerk of Council is hereby directed to deliver a certified copy of this Ordinance to the County Auditor within twenty days after its passage.

SECTION VII.

That it is hereby found and determined that all formal actions of this Council concerning and relating to the passage of this Ordinance were adopted in an open meeting of this Council, and that all deliberations of this Council and of any of its committees that resulted in such formal action, were in meetings open to the public, in compliance with all legal requirements including Section 121.22 of the Ohio Revised Code.

SECTION VIII.

This ordinance shall take effect as of the earliest date permitted by law.

PASSED BY COUNCIL this \_\_\_\_ day of \_\_\_\_\_, 2022.

\_\_\_\_\_  
Mayor William D. Duncan

ATTEST:

\_\_\_\_\_  
Clerk of Council

To the Clerk:  
Please publish in summary form set forth below.

\_\_\_\_\_  
City Attorney Robert F. Jacques

LEGAL NOTICE

On \_\_\_\_\_, Council of the City of Oakwood, passed Ordinance No. \_\_\_\_\_ entitled  
“DETERMINING TO PROCEED WITH THE IMPROVEMENT OF CERTAIN STREETS  
BETWEEN CERTAIN TERMINI IN THE CITY OF OAKWOOD, OHIO, BY LIGHTING THE  
SAME WITH ELECTRICITY.”

Lori Stacel  
Clerk of Council  
City of Oakwood

CERTIFICATION OF PUBLICATION

I, Lori Stacel, Clerk of Council of the City of Oakwood, State of Ohio, do hereby certify that the  
foregoing summary of the foregoing Ordinance was duly published in the Oakwood Register, a  
newspaper of general circulation in said City of Oakwood, that said publication occurred on the  
following date:

\_\_\_\_\_  
Lori Stacel, Clerk of Council

A RESOLUTION

BY: \_\_\_\_\_

NO. \_\_\_\_\_

AUTHORIZING AN UPDATED AGREEMENT WITH MONTGOMERY COUNTY OFFICE OF EMERGENCY MANAGEMENT TO PROVIDE EMERGENCY MANAGEMENT SERVICES FOR THE CITY OF OAKWOOD, MONTGOMERY COUNTY, OHIO.

WHEREAS, as authorized by Resolution No. 1578, there currently exists between the city of Oakwood, Ohio and the Board of Commissioners of Montgomery County, Ohio, an agreement that the County, through its Office of Emergency Management, shall provide emergency management services for the City in conjunction with a countywide coordinated program; and

WHEREAS, the existing agreement has not been updated since 2003, and the County has proposed an updated and revised agreement that would require renewal every three (3) years to ensure it continues to meet the emergency management needs of the entire region; and

WHEREAS, Council wishes to continue the city’s participation in the countywide coordinated program;

NOW, THEREFORE, BE IT RESOLVED BY THE COUNCIL OF THE CITY OF OAKWOOD, MONTGOMERY COUNTY, OHIO:

SECTION I.

The Council of the city of Oakwood hereby approves the updated Jurisdictional Emergency Management Services Agreement. Although the original will be executed and submitted to the County in electronic format, a document summarizing the substantive provisions of the agreement is attached hereto and incorporated by this reference.

SECTION II.

The City Manager is hereby authorized to sign the updated Jurisdictional Emergency Management Services Agreement on the city’s behalf, electronically and/or otherwise, and to submit the same to the Montgomery County Office of Emergency Management.

SECTION III.

The Clerk of Council is directed to certify a copy of this resolution upon its passage, and to promptly forward the same to the Montgomery County Office of Emergency Management.

SECTION IV.

This resolution shall take effect upon its passage.

PASSED BY COUNCIL OF THE CITY OF OAKWOOD, this \_\_\_\_ day of \_\_\_\_\_, 2022.

\_\_\_\_\_  
Mayor William D. Duncan

ATTEST:

\_\_\_\_\_  
Clerk of Council

TO THE CLERK:

No publication is required.

\_\_\_\_\_  
City Attorney Robert F. Jacques

## **Jurisdictional Emergency Management Services Agreement**

### **RECITALS**

The coordination of emergency management and homeland security activities is of paramount importance to all municipal corporations and townships, herein known as Political Subdivisions, within Montgomery County. Therefore as required by law pursuant to Section 5502.26 of the ORC, the Montgomery County Office of Emergency Management, herein known as MCOEM, is established to confer upon the Board of County Commissioners and the Director of MCOEM certain emergency powers provided herein; and to provide for the rendering of cooperation of mutual aid, if necessary, to surrounding and contiguous political subdivisions of the State and adjoining states.

MCOEM will serve local subdivisions providing mitigation, preparation, response, and recovery support for emergencies, disasters, enemy attack, or any other action too great to be dealt with unassisted.

Montgomery County desires to effect said coordination by entering into an agreement as permitted by Section 307.15 of the ORC, in the manner provided by law, with the Political Subdivisions comprising Montgomery County.

It is further declared to be the purpose of this Agreement and the policy of Montgomery County that all emergency management and homeland security functions of the County be coordinated with comparable functions of the State of Ohio and of the Federal Government, including their various departments and agencies, and other states and localities, and of private agencies of every type, so that the most effective preparation and use can be made of the County's resources and facilities for dealing with any disaster or emergency that may occur.

### **REPRESENTATIONS AND WARRANTIES**

IT IS THEREFORE MUTALLY AGREED:

1. A countywide emergency management agency organized under ORC 5502.26 and this agreement shall establish a program for emergency management that:
  - a. Is in accordance with sections 5502.21 to 5502.51 of the Revised Code, rules adopted under those sections, local ordinances pertaining to emergency management, the "Robert T. Stafford Disaster Relief and Emergency Assistance Act," 88 Stat. 143, 42 U.S.C. 5121, et. seq., as amended, and all applicable rules and regulations adopted under that act;
  - b. Includes, without limitation, development of an all-hazards emergency operations plan that has been coordinated with all agencies, boards, and divisions having emergency management functions within the county;

- c. Includes the preparation and conduct of an annual exercise of the county's all-hazards emergency operations plan;
  - d. Is applicable to all political subdivisions entering into the countywide agreement.
2. A representative from each political subdivision entering into the agreement, selected by the political subdivision's chief executive, shall constitute a countywide advisory group for the purpose of appointing an executive committee through which the countywide agency shall implement emergency management in the county in accordance with ORC 5502.26 and for the purpose of advising the executive committee on matters pertaining to countywide emergency management. The executive committee shall consist of at least the following seven members: one (1) county commissioner representing the board of county commissioners entering into the agreement; four (4) chief executives representing the municipal corporations and townships entering into the agreement; one (1) chief executive of the largest municipal corporation of the county; and one (1) nonelected representative.
3. The executive committee shall appoint a director/coordinator of emergency management who shall pursue a professional development training program in accordance with rules adopted under section 5502.25 of the Revised Code. The director/coordinator of emergency management may be an official or employee of any political subdivision entering into the countywide agreement, except that the director/coordinator shall not be the chief executive of any such political subdivision. The compensation of the Director and staff shall be paid from MCOEM's budget. The director/coordinator of emergency management for a countywide agency organized under this section shall be responsible for coordinating, organizing, administering, and operating emergency management in accordance with the agency's program established under this section, subject to the direction and control of the executive committee. All agencies, boards, and divisions having emergency management functions within each political subdivision within the county shall cooperate in the development of the all-hazards emergency operations plan and shall cooperate in the preparation and conduct of the annual exercise.
4. Said executive committee shall convene at least twice within a calendar year and upon the request of MCOEM's Director. Special meetings may be held for the execution of unforeseen business requiring immediate attention. The Executive Committee Chair and/or three Executive Committee members may request such meetings be called.
5. There shall also be established, pursuant to this agreement, an Emergency Management Technical Advisory Committee.
6. MCOEM is authorized to render the services of coordinating emergency management and homeland security activities of each party hereto and to exercise such power and authority, on behalf of said parties, consistent with the State and Federal statutes and such regulations as have been or shall be promulgated by the Governor of the State, the



provisions of this Agreement as hereinafter set forth, and the power of the parties hereto authorized, in coordinating such emergency management and homeland security activities within Montgomery County.

7. The agency, MCOEM, shall be supported financially by the political subdivisions entering into the countywide agreement. Jurisdictions entering into the countywide agreement will be required to contribute a per capita rate of \$0.2 for each citizen within their respective jurisdiction. The Montgomery County Board of County Commissioners shall be requested to pay an equivalent per capita fee of \$0.2 for each resident of Montgomery County. The Director shall prepare and submit for review and approval, a budget annually to the Montgomery County Board of County Commissioners.
  - a. Nonmember political subdivisions within Montgomery County shall be subject to a fee for services rendered by MCOEM. Said fee will be itemized and based on actual personnel, travel, and equipment usage expenses.
8. This agreement stands for a term not to exceed three (3) years and may be amended or altered at any time by a majority of the parties hereto.
  - a. This agreement shall be in full force and effect when no less than a majority of the political subdivisions of Montgomery County and the County Commissioners of Montgomery County shall have subscribed to this agreement by adopting a like resolution or passing a like ordinance, and shall continue in full force and effect thereafter unless terminated by the Montgomery County Board of County Commissioners.
  - b. This agreement may be terminated singularly by a city, village, or township at the end of any calendar year by action of its legislative authority and service of written notice thereof to the MCOEM executive committee not less than ninety (90) days prior to the end of said calendar year. However, any Political Subdivision that exercises a termination, shall organize an emergency management program under the provisions set-forth in ORC 5502.271, and shall be subject to paragraph 6.a above.

This agreement is declared to be an emergency measure and shall take effect and be in force from and after its passage by the Montgomery County Board of County Commissioners, and its adoption by the respective legislative bodies of the majority of the other political subdivisions.