

Streets

- Design and Construction Guidelines
- Construction Standards

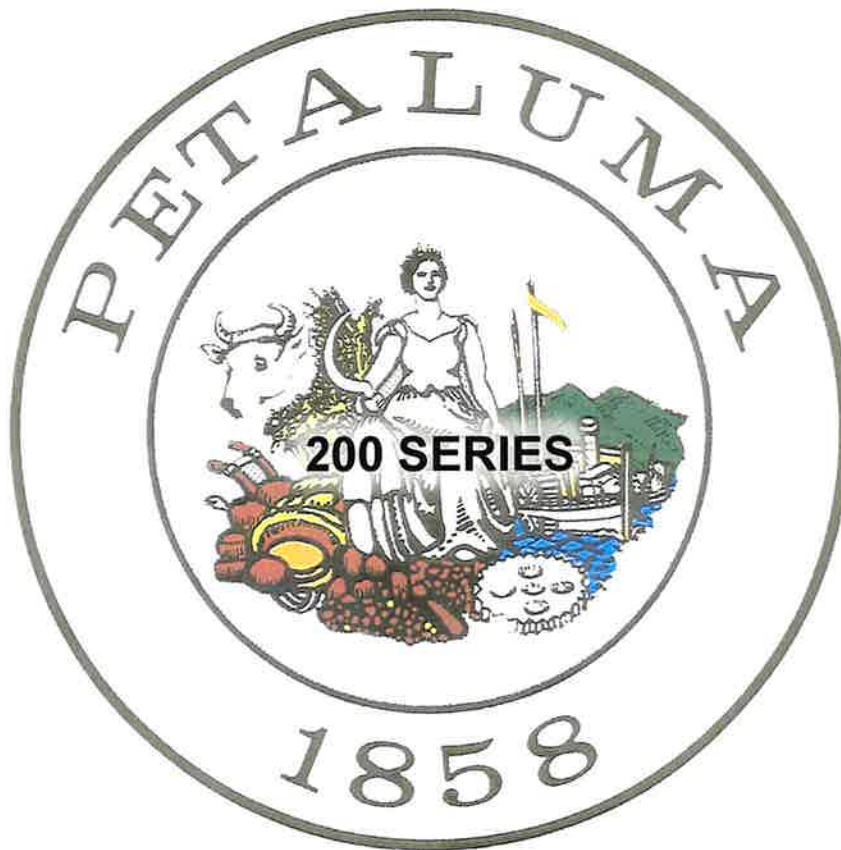

City of Petaluma - Sonoma County - California
Public Works & Utilities
202 North McDowell Boulevard
Petaluma, CA 94954

APPROVED BY:

6/17/2024

Kent R. Carothers, P.E., City Engineer

Date

Street Construction Standards

Table of Contents

<u>Std. No.</u>	<u>Title</u>	<u>Date Approved</u>
201.1	Department of Engineering Street Standards Design and Application Guidelines	Mar 1997
201.2	Standard Street Configuration (Arterial Street)	Nov 1996
201.3	Standard Street Configuration (Collector Street).....	Nov 1996
201.4	Standard Street Configuration (Residential Street)	Nov 1996
201.5	Standard Street Configuration (Minor Residential Street)	Nov 1996
201.6	Standard Street Configuration (Reduced Minor Residential Street)	Nov 1996
201.7	Standard Street Configuration Details	Mar 1997
202.1	Curb, Gutter, and Sidewalk (General Notes).....	Sep 1996
202.2	Curb Markings for Service Laterals	Jun 2024
202.3	Standard Curb and Gutter Details	Jun 2024
203.1	Curb, Gutter, Sidewalk, and Driveway.....	Jun 2024
203.2	Misc. "NEW" Construction Sections	Jun 2024
204.1	Standard Curb and Gutter (w/ Non-Expansive Backing – with Curb Anchor)	Feb 1998
204.2	Curb and Gutter (Vertical Curb – Curb and Fall Away Gutter – A.C. Curb)	Sep 1996
205.0	Valley Gutter	Sep 1996
206.1	Curb Ramp Type-A Detail.....	Feb 1998
206.2	Curb Ramp Type-B Detail.....	Feb 1998
206.3	Curb Ramp Type-C Detail	Feb 1998
207.0	Driveway Culvert (For High Crown Streets)	Sep 1996
208.1	Street and Stop Signs.....	Sep 1996
208.2	Street and Stop Signs (Locations and Notes)	Oct 1996
208.3	Street Name Signs Detail	Oct 1996
209	Stop Bar and Stop Word Detail	Sep 1996
213.1	Gas, Electric, Telephone, Cable, and Traffic Signal Trench Details	Oct 1996
213.2	Trench Plating in Streets	Oct 1996
214.1	City Monument Detail	Oct 1996
214.2	City Monument Cover	Sep 1996
214.3	Brass Survey Marker	Oct 1996
215.0	Standard Barricade Detail.....	Sep 1996
216.1	Major Reconstruction – Retention of Cobblestone (Curb and/or Gutter)	Sep 1996
216.2	Minor Reconstruction – Retention of Cobblestone (Curb and/or Gutter)	Sep 1996
216.3	Major Treatment for Tree Roots	Sep 1996
217.1	Standard Hammerhead Turn Around	Sep 1996
217.2	Standard Cul-De-Sac.....	Oct 1996
217.3	Standard Street Configuration (Minor Residential Cul-De-Sac Street)	Nov 1996
217.4	Standard Street Configuration (Residential Cul-de-Sac Street	May 1999

Street Construction Standards

Table of Contents (continued)

<u>Std. No.</u>	<u>Title</u>	<u>Date Approved</u>
218.1	Side Street and End of Overlay Conform	Dec 1998
218.2	Edge Grinding at New Structural Section	Dec 1998
218.3	Edge Grinding at Lip of Gutter with Overlay Section	Dec 1998
219.1	Standard Trench Detail.....	Jan 2019
219.2	Standard Trench Detail Notes	Jan 2019
219.3	Pavement Resurfacing Limits for Public Right-of-Way.....	Jan 2019
225.0	Driveway Apron with Gutter Grate, High Crown Street	Jun 2024

Special Note: For Pavement Marking and General Notes, Markers and Traffic Lines, Construction Signing and Safety Notes, see current copy of State of California, Department of Transportation Manuals & Standards.

City of Petaluma

Department of Engineering

Street Standards

Design and Application Guidelines

DESIGN FEATURE	ARTERIAL	COLLECTOR	RESIDENTIAL	MINOR (5) RESIDENTIAL	REDUCED (5) MINOR RESIDENTIAL
Lanes					
Number	4	2	2	2	2
Lane Width	12'-0"	12'-0"	10'-0"	9'-0"	8'-0"
Median Width	10'-0" - 20'-0"	8'-0" - 16'-0"	8'-0" - 12'-0"	6'-0" - 9'-0"	6'-0" - 9'-0"
Left Turn Lane	YES	NO (1)	NO	NO	NO
Right Turn Lane	YES	NO	NO	NO	NO
Bicycle Lane	YES	NO (2)	NO	NO	NO
Parking	YES	NO	YES	YES	NO
Design Speed (M.P.H.)	45	35	25	20	15
Center Line Radius	1000'-0"	500'-0"	250'-0"	125'-0"	(3)
Intersection Spacing (4)	350'-0"	200'-0"	150'-0"	125'-0"	N/A
Sidewalks	YES	YES	YES	YES	YES
Width	6'-0"	5'-0"	5'-0"	5'-0"	5'-0"
Planter	YES	YES	YES	YES	YES
Width	8'-0"	7'-0"	6'-0"	6'-0"	6'-0"
Access	LIMITED	YES	YES	YES	YES
Dwellings Served	N.A.	400	200	100	20
Traffic Volumes Average Daily Traffic (A.D.T.)	6,000 - 25,000	2,000 - 6,000	Less than 2,000	Less than 1,000	Less than 200
Continuity	1-Mile	1-2-Mile	N.A.	N.A.	N.A.

NOTES

1. Left turn lanes may be considered at intersections to Arterial Streets.
2. Bicycle Lanes may be considered near schools and Connectors to other Bicycle Elements.
3. Centerline Radius to be considered at time of Design
4. Minimum Acceptable
5. Driveway locations to be staggered with driveways on opposite side of the Street

CITY OF PETALUMA Department of Engineering

22 Bassett Street - Petaluma California 94952
707 778 4304 - Fax 707 778 4437

Approved By

Thomas S. Haugs
Thomas S. Haugs - R.C.E. 2252

STREET STANDARDS

Design and Application
Guidelines

Drawn By

Butch Smith

Scale

N T S

Date

March 28th 1997

File Name

STANDARDS.DWG 201 1 1 1 1



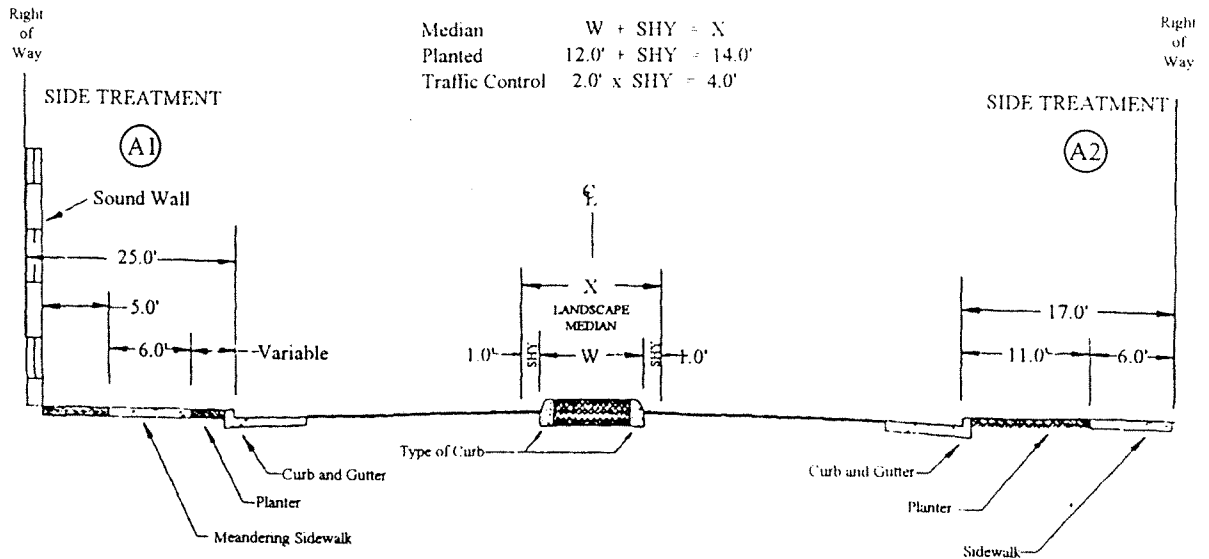

Arterial Street Detail

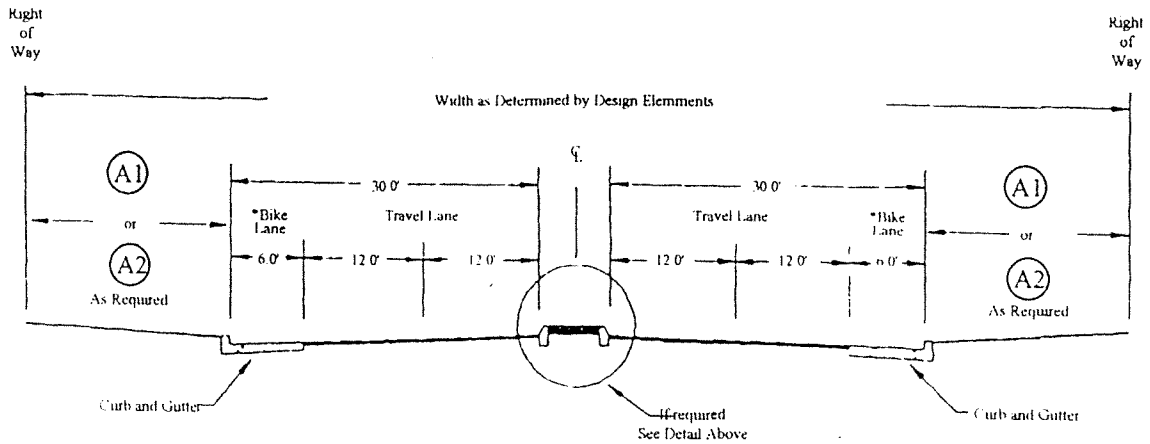

Arterial Street

(N) Refer to Detail as shown above

* Add 8' with Parking

Structural Section Design T1 shall be determined by the City Engineer for all Arterial Streets.

Street Design Elements

Operating Speed	Centerline Radius	Intersection Spacing	Traffic Volumes	Driveway Access	Sidewalks
45 MPH	1000'	350'	11 - 20,000	Limited	Yes

CITY OF PETALUMA
 Department of Engineering

22 Bassett Street - Petaluma California 94952
 707 778 1304 - Fax 707 778 4437

Approved By

Ed Hagen

Phone 707 778 1304 - Fax 707 778 4437

STANDARD
 STREET
 CONFIGURATION

Arterial Street

Drawn By
 Butch Smith

Scale
 N T S

Date
 November 12th 1996

File Number
 Std Det - 1858



Page
 2 of 2

Median W - SHY - X
 Planted 12.0' - SHY - 14.0'
 Traffic Control 2.0' x SHY - 4.0'

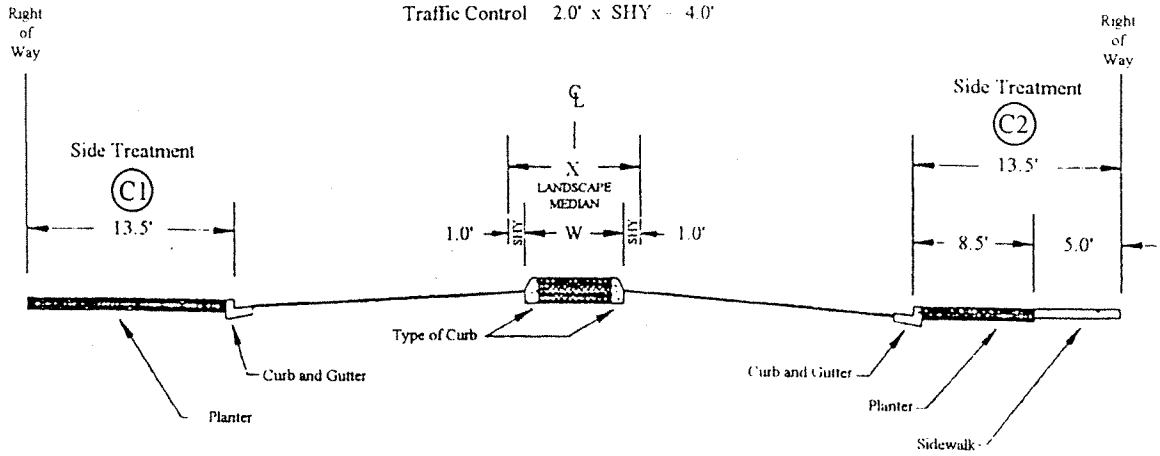

Collector Street Detail

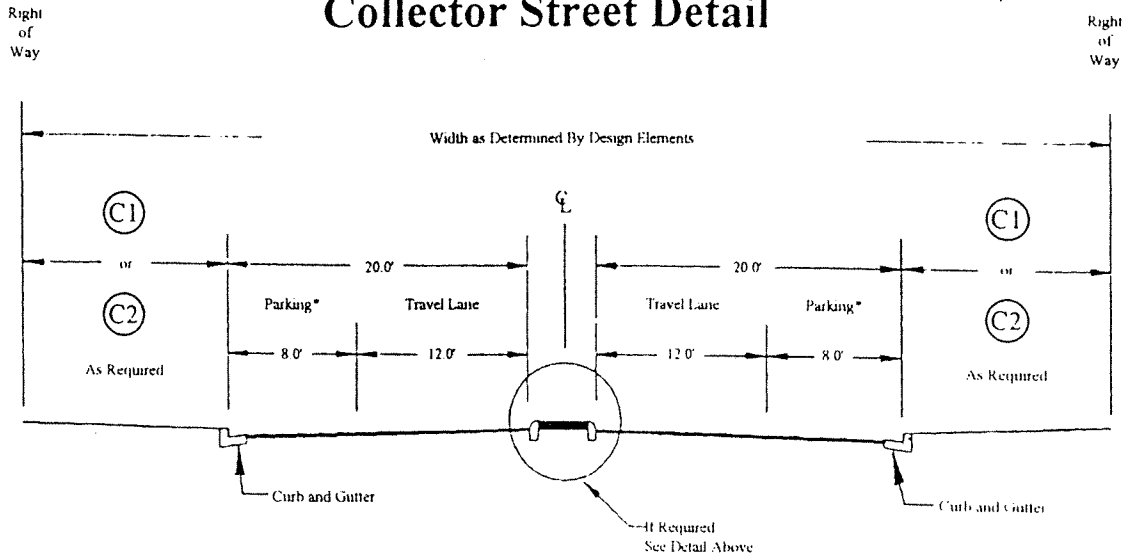

Collector Street

(N) Refer to Detail as shown above

* = Add 8.0' with Parking

Street Structural Section shall be Designed to meet T 1 - 60

Street Design Elements

Operating Speed	Centerline Radius	Intersection Spacing	Traffic Volumes	Driveway Access	Sidewalks
35 MPH	500'	200'	2 - 6,000	Yes	Yes

CITY OF PETALUMA
 Department of Engineering

22 Bassett Street - Petaluma California 94952
 707 778-4304 - Fax 707 778-4137

Approved By

Thomas S. Harris
 Thomas S. Harris

STANDARD STREET CONFIGURATION
 Collector Street

Drawn by
 Butch Smith

Scale
 N T S

Date
 November 12th 1996

File Number

2-11-96 SS0000 201



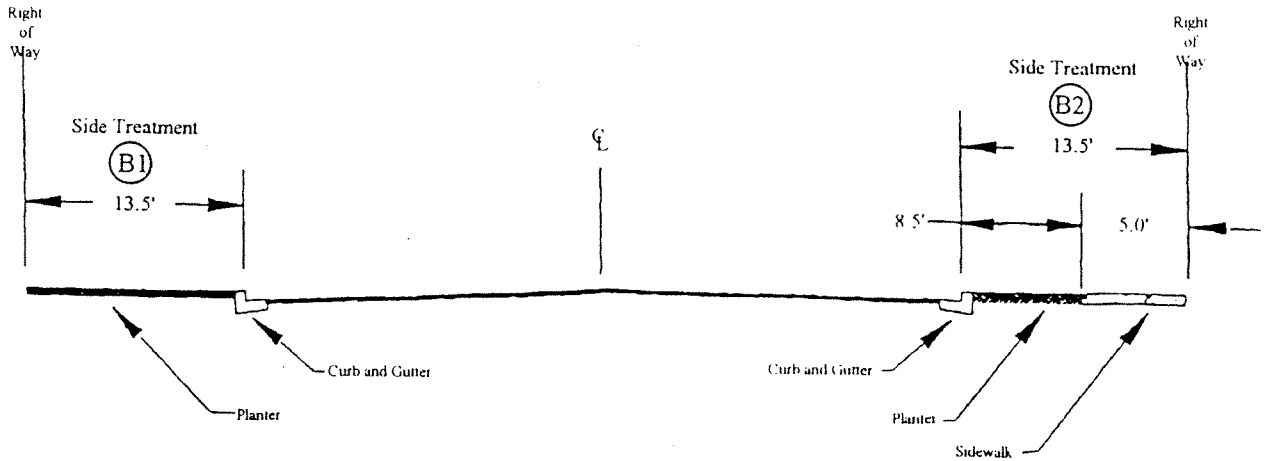

Residential Street Detail

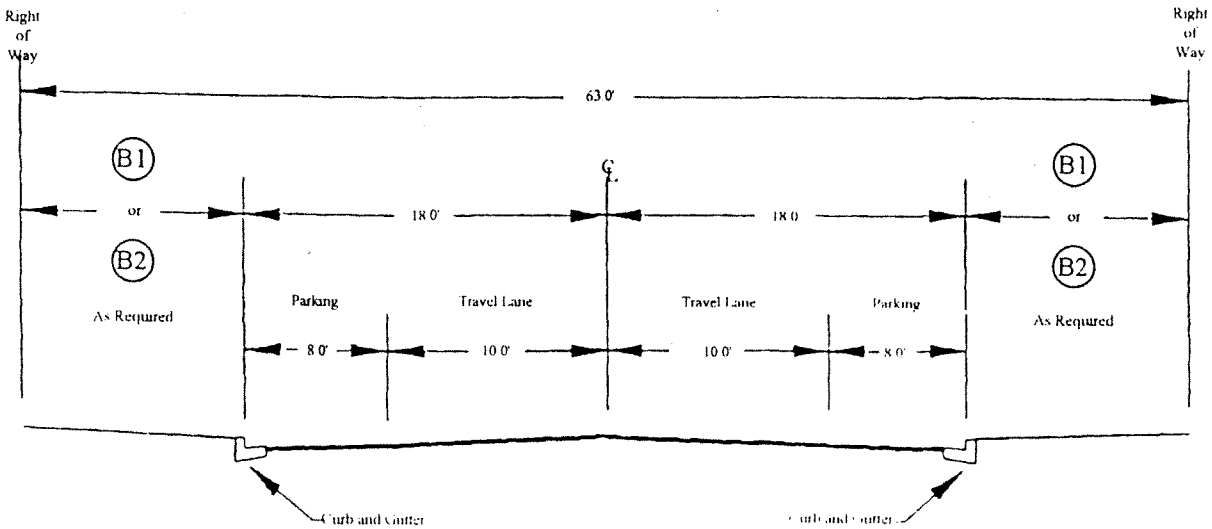

Residential Street

(N) Refer to Detail as shown above

Street Structural Section shall be Designed to meet T.I. = 5.0

Street Design Elements

Operating Speed	Centerline Radius	Intersection Spacing	Traffic Volumes	Driveway Access	Sidewalks
25 MPH	250'	125'	2 000	Yes	Yes

CITY OF PETALUMA
Department of Engineering

22 Bassett Street - Petaluma California 94952
707-778-1401 - Fax 707-778-4437

Approved By

[Signature]

Thomas S. Larson R.C.E. 22266

STANDARD STREET CONFIGURATION
Residential Street

Drawn By

Butch Smith

Scale

N T S

Date

November 12th 1996

File Number

S.L.D. 201-1-10-7



Page

2 of 2

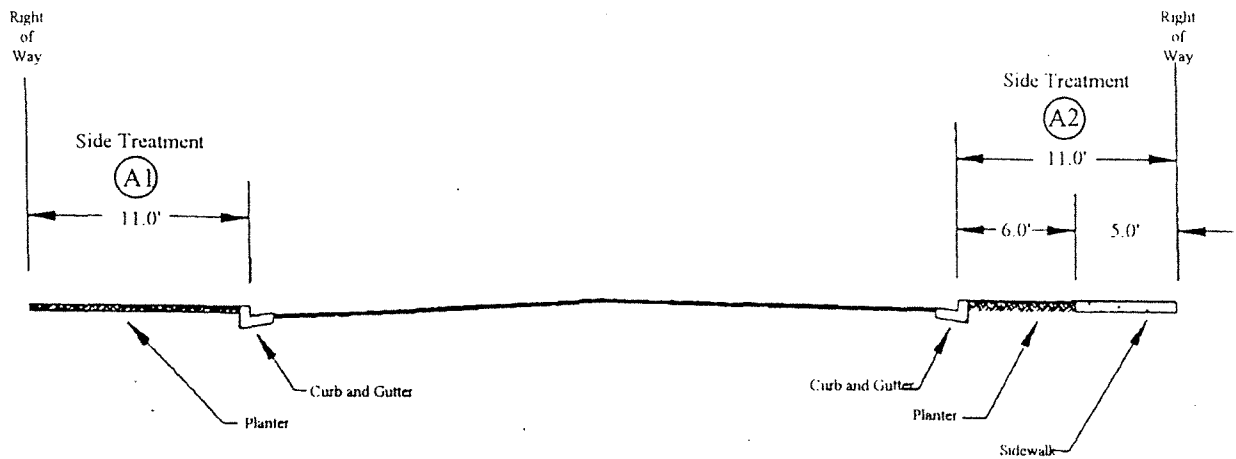

Minor Residential Street Detail

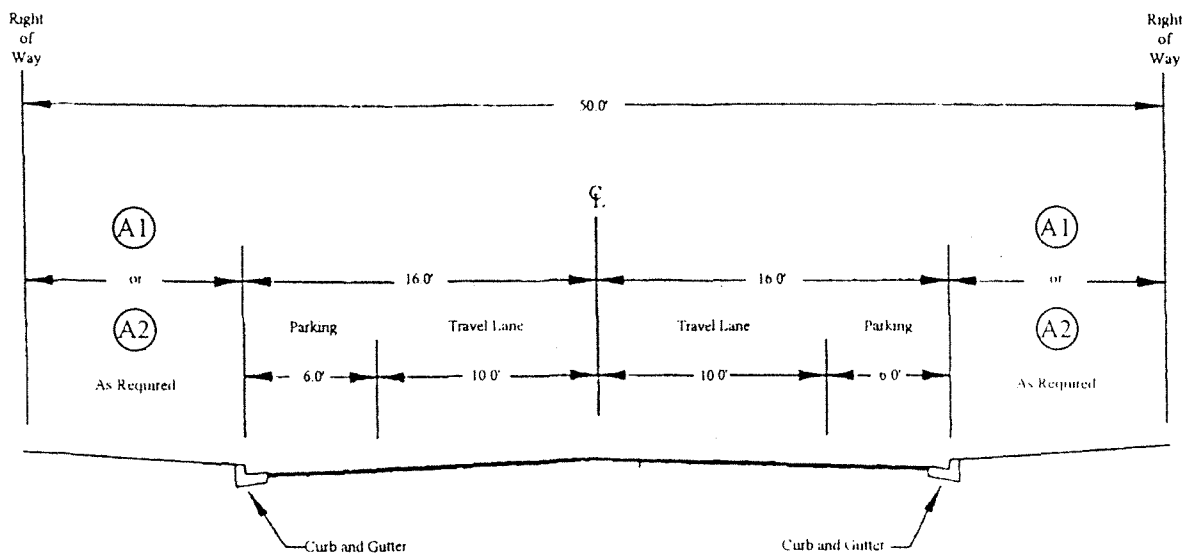

Minor Residential Street

(N) Refer to Detail as shown above

Street Design Elements

Street Structural Section shall be Designed to meet T.I. 5.0

Operating Speed	Centerline Radius	Intersection Spacing	Traffic Volumes	Driveway Access	Sidewalks
20 MPH	175'	125'	250	Yes	Yes

CITY OF PETALUMA
Department of Engineering

22 Bassett Street - Petaluma California 94952
707 778 4304 - Fax 707 778 4437

Approved By
Thomas S. Hargis
Thomas S. Hargis, R.C.E., P.E.

STANDARD STREET CONFIGURATION

Minor Residential Street

Drawn By
Butch Smith
Scale
N.T.S.
Date
November 12th 1996
File Number
Std Det. SSD0000 201



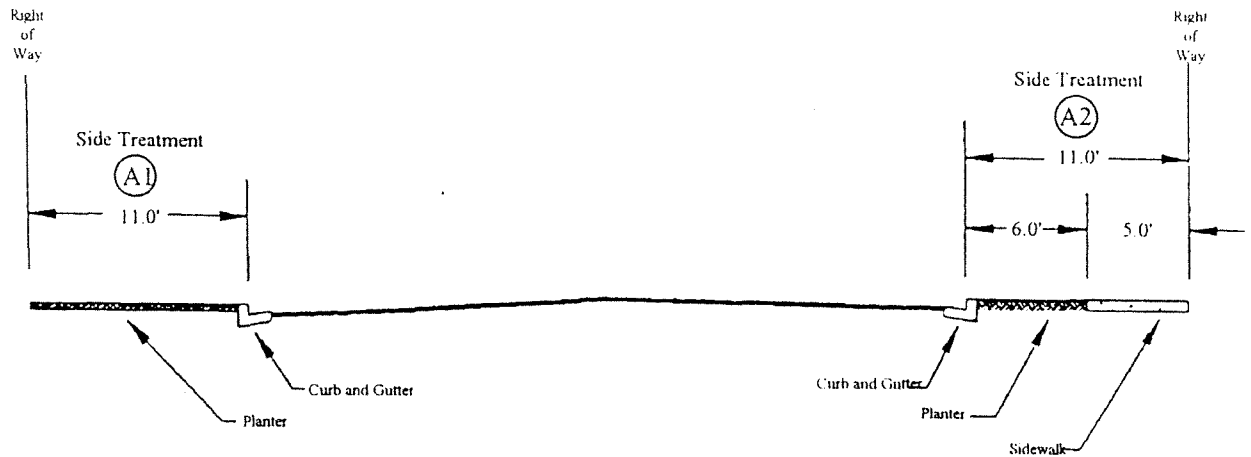

Reduced Minor Residential Street Detail

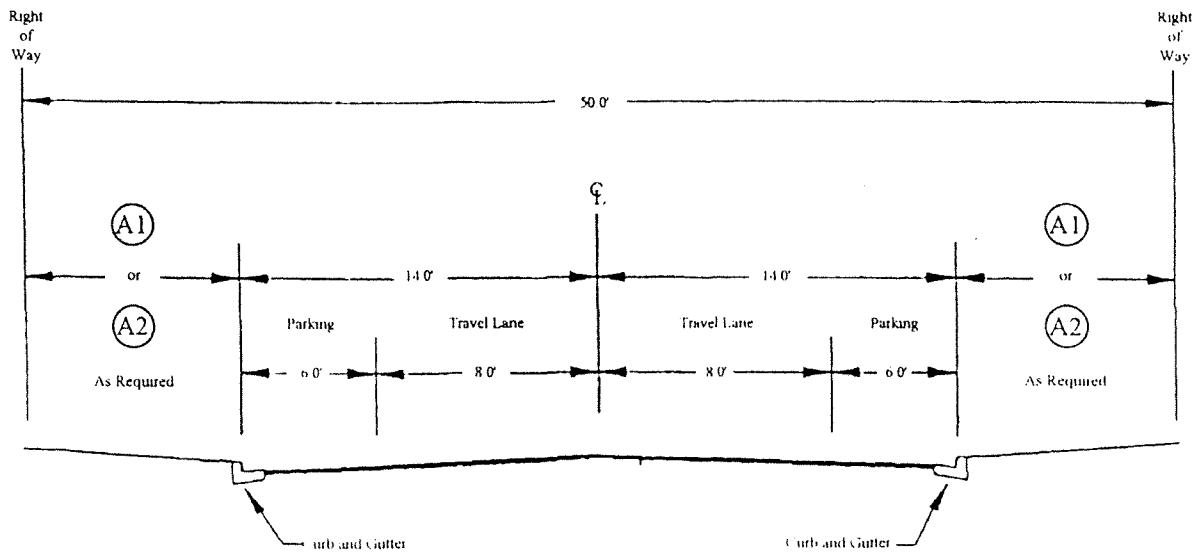

Reduced Minor Residential Street

(N) Refer to Detail as shown above

Street Structural Section shall be Designed to meet T.I. 5.0

Street Design Elements

Operating Speed	Centerline Radius	Intersection Spacing	Traffic Volumes	Driveway Access	Sidewalks
20 MPH	175'	125'	250	Yes	Yes

CITY OF PETALUMA
Department of Engineering

22 Bassett Street - Petaluma California 94952
707 778 1304 - Fax 707 778 4437

Approved By:

Thomas S. Hargis

Thomas S. Hargis - R.C.E. 22366

STANDARD STREET CONFIGURATION

Reduced Minor Residential Street

Drawn by
Butch Smith

Scale

N T S

Date

November 12th 1996

File Number

SS10090 201.6 of 7



Median $W + SHY = X$
 Planted $8 + SHY = 10.0'$
 Traffic Control $2 + SHY = 4.0'$

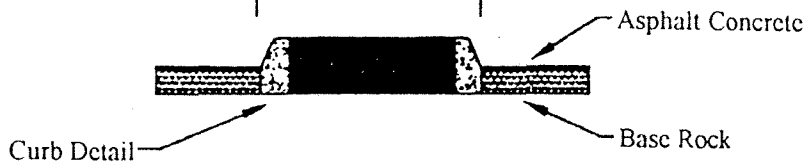
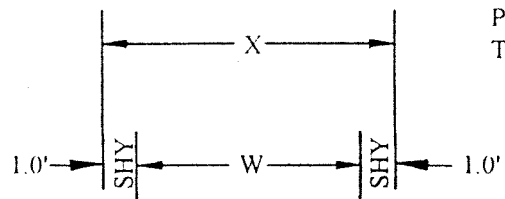

DETAIL "A"

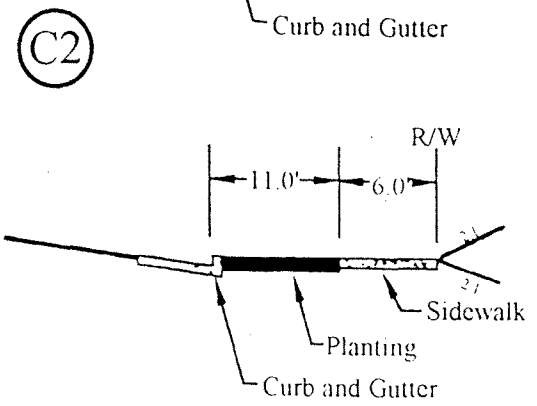
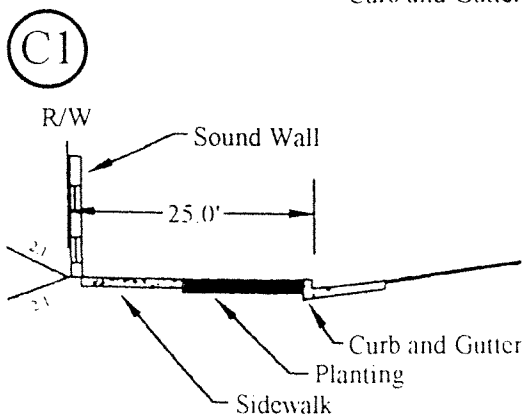
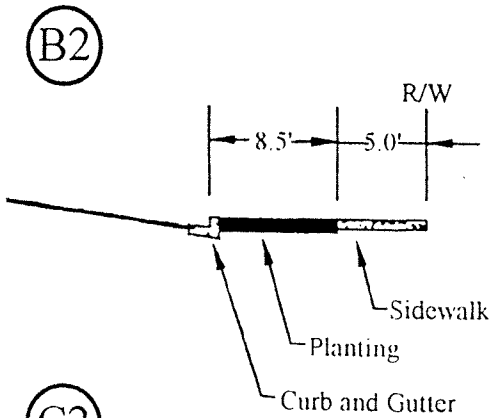
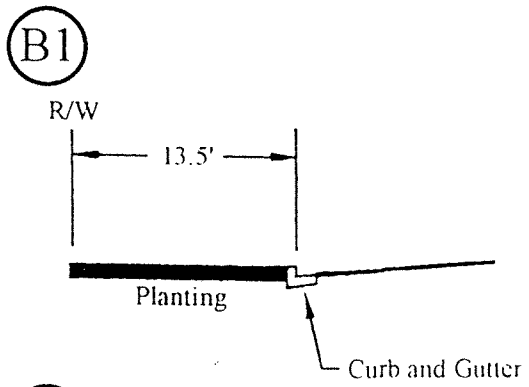
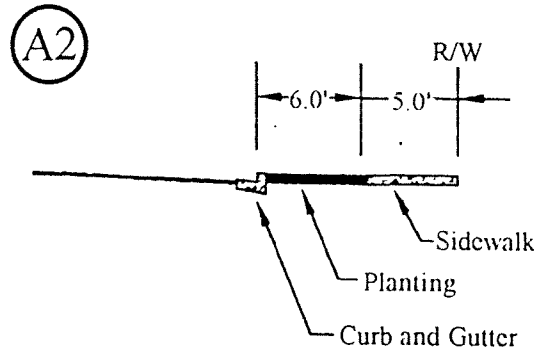
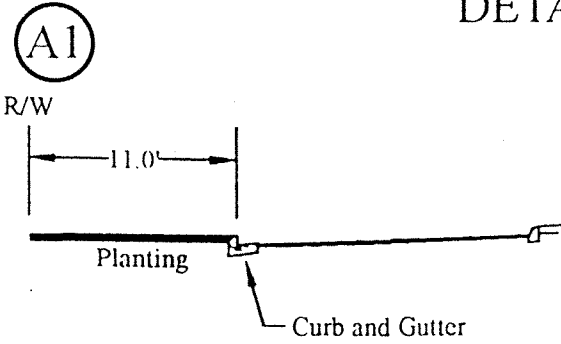

CITY OF PETALUMA
 Department of Engineering
 22 Bassett Street - Petaluma, California 94952
 Phone 707 778 1504 Fax 707 778 4437
 Approved By
Tom Hargis
 Thomas S. Hargis, P.E., C.E.

STANDARD
 STREET
 CONFIGURATION
 Details

Drawn by
 Butch Smith
 Scale
 N T S
 Date
 March 28th 1997
 File Number
 SLD 000 000 000 000 000



1. Compact all Subgrade to Minimum of 92% at 4 to 6 Percentage Points over opt. Moisture. (See STANDARD DETAIL SPECIFICATION NO. 41, Section 202.2)
2. Flowline of Gutter is 2" below the Lip of Gutter and 2-1/4" below the Edge of Pavement.
3. Top of Curb is 6" above Flowline; i.e. 6" Curb Height.
4. Concrete to be Class "B" (5-Sack per Cubic Yard) with 2" to 4" Slump. If placed by *Extrusion Machine*, concrete to be Class "B" (5-1/2-Sack per Cubic Yard) (See STANDARD DETAIL SPECIFICATION NO.41 Section 202.8)
5. Monolithic Curb, Gutter and Sidewalk require 1/4" *Premold Joint Filler* and 4-1/2" x 20" Smooth Steel Dowels every 60'-0", 4-1/2" rebars between Expansion Joints are required where soil is expansive (Adobe-Clay). If placed by *Extrusion Machine*, *Premold Joint filler* not required. Machine pours require 4-1/2" Smooth Steel Dowels at Cold Joints. **NO** other Steel required.
6. Use 1/2 Pound of *Lampblack* per Cubic Yard of Mix.
7. Weakened Plane Joints in Curb, Gutter and Sidewalk shall be placed of intervals not to exceed 20-Fect, the Removable Joint forming Plates shall extend through not less than the upper 1/2" (1-3/4") of Sidewalks and completely through the Curb to at least 2-3/4" below the top of the Gutter.
8. Aggregate under Curb, Gutter, Sidewalk and Driveways shall be 3/4" Maximum size Class 2 Aggregate Sub-Base or 3/4" maximum size Class 2 Aggregate Base.
9. If Calcium Chloride is to be added to the Concrete (**On Approval Only**), 1/2 Sack Cement per Cubic Yard shall be added for each 1% of Calcium Chloride (CC) not to exceed 2%.

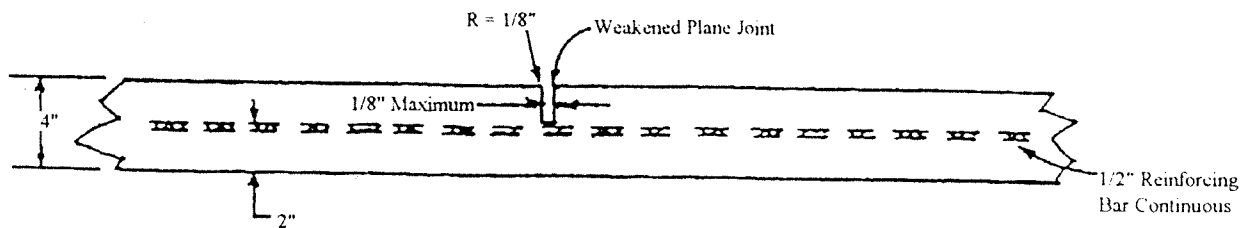

PROFILE - WEAKENED PLANE JOINT

<p>CITY OF PETALUMA Department of Engineering 22 Bassett Street - Petaluma California 94952 707 778-4304 - Fax 707 778-4317</p> <p>Approved By: <i>Thomas S. Hurgis</i> Thomas S. Hurgis - E.C.E. 22366</p>	<p>Standard Details CURB, GUTTER SIDEWALK General Notes</p>	<p>Drawn By Butch Smith Scale N T S Date September 4th 1996 File Number Std Det SSD0000 202 1 of 2</p>	 <p>Page 202</p>
---	--	--	---

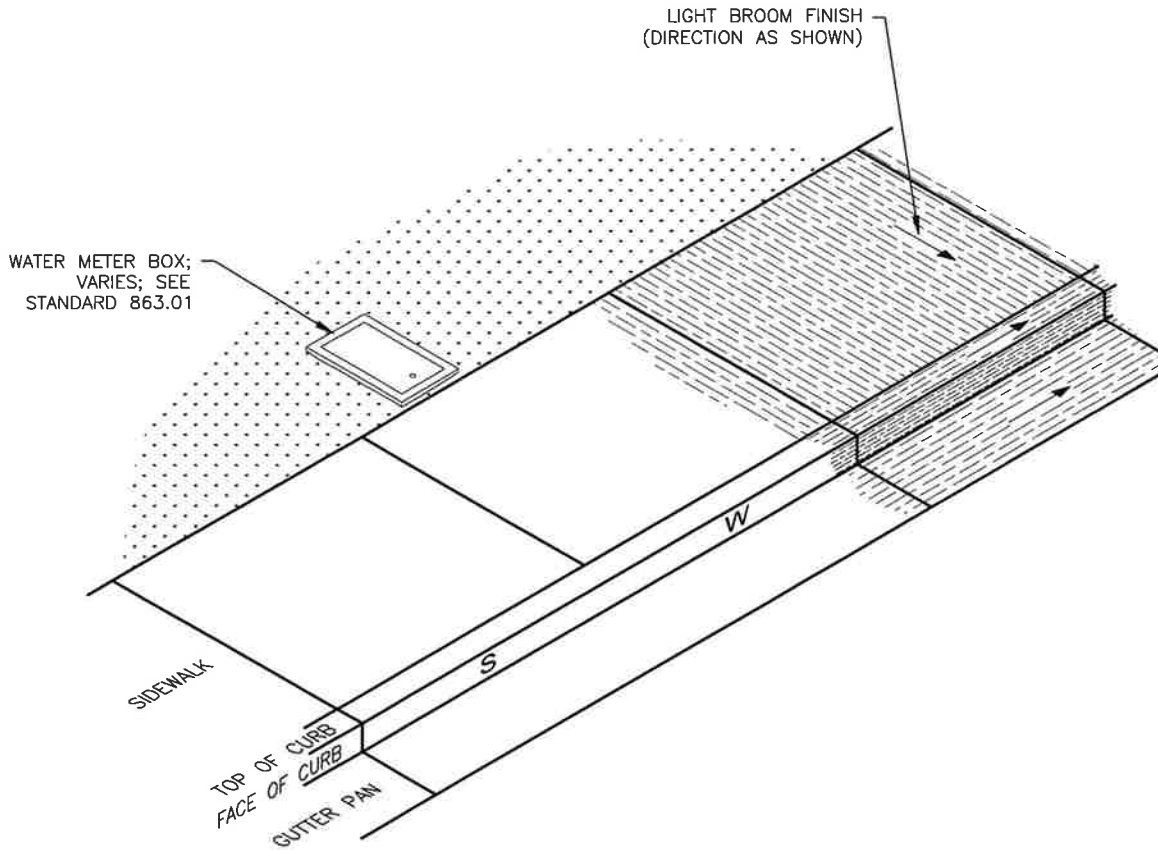

NOTES:

1. THE FACE OF CURB SHALL BE STAMPED WITH THE APPROPRIATE LETTER, DIRECTLY OVER THE SERVICE LATERAL.
 "S" = SANITARY SEWER LATERAL
 "W" = WATER SERVICE LATERAL
2. STAMPS SHALL BE CONSTRUCTED SUCH THAT THEY WILL LEAVE A CLEAR, CLEAN IMPRESSION AT LEAST 3/16" IN DEPTH. LETTERS SHALL BE A MINIMUM OF 3-1/2" HIGH BUT NO MORE THAN 4". SCRATCHING IN LETTERS WITH STICKS OR OTHER OBJECT WILL NOT BE ALLOWED.
3. IT WILL BE THE RESPONSIBILITY OF THE UNDERGROUND CONTRACTOR TO VISIBLY REFERENCE ALL SERVICE LATERALS PRIOR TO POURING CURB, GUTTER AND SIDEWALK.



CITY OF PETALUMA

PUBLIC WORKS & UTILITIES
 UTILITIES DIVISION

202 N. McDOWELL BLVD. TEL. 707-778-4546
 PETALUMA, CALIFORNIA 94954 FAX. 707-778-4508

STANDARD DETAILS
 CURB MARKINGS FOR
 SERVICE LATERALS

DATE: JUNE 2024

SCALE: N.T.S.

APPROVED BY: *Kent R. Carothers*
 Kent R. Carothers, P.E. City Engineer C60671

DRAWN BY: ETL

NO. 202.2

TYPICAL CURB & GUTTER PROFILES

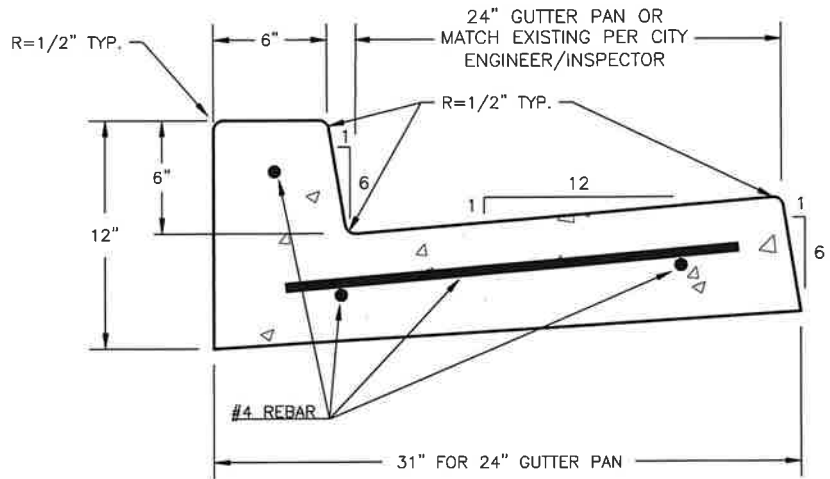

LEGACY CURB & GUTTER

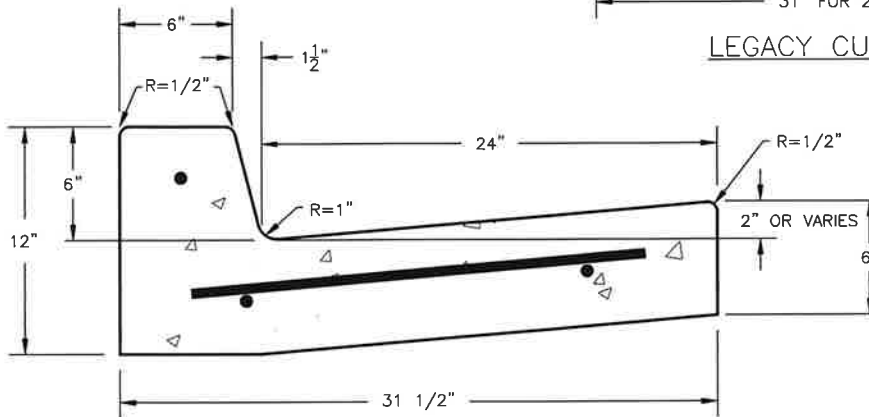

CALTRANS CURB (2022 TYPE A2-6)

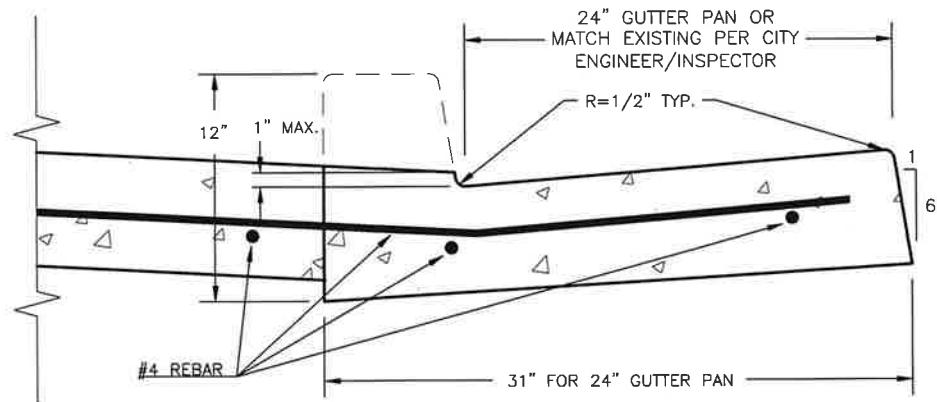

CURB & GUTTER AT DRIVEWAY

NOTES:

1. CURB & GUTTER SHALL BE OF PORTLAND CEMENT CONCRETE AS PER CITY SPECIFICATIONS.
2. EXPANSION JOINTS ARE REQUIRED AT 60'-0" INTERVALS WITH 3 EACH 1/2" DIAMETER REBAR DOWELS AND CROSSBARS AT 24" SPACING.
3. SCARIFY ALL SUBGRADE AND COMPACT TO 95% AT OPTIMUM MOISTURE CONTENT.
4. COMPACT ASB OR AB TO 95% AT OPTIMUM MOISTURE CONTENT.
5. REFER TO SIDEWALK SECTION.

FOR EXPANSIVE SOILS SEE CURRENT CITY OF PETALUMA STREET CONSTRUCTION DETAIL SPECIFICATION, PARAGRAPH 2.2, "RELATIVE COMPACTION".
 CONTRACTOR MUST REMOVE A MINIMUM OF 12" OF AC--OR MORE AT THE DISCRETION OF THE CITY ENGINEER, TO FORM FOR CURB AND GUTTER OR DRIVEWAY APPROACH.



CITY OF PETALUMA
 PUBLIC WORKS & UTILITIES
 UTILITIES DIVISION
 202 N. McDOWELL BLVD. TEL. 707-778-4546
 PETALUMA, CALIFORNIA 94954 FAX. 707-778-4508

STANDARD DETAILS
 STANDARD CURB &
 GUTTER DETAILS

DATE: JUNE 2024 SCALE: N.T.S.

APPROVED BY:

 Kent R. Carothers, P.E. City Engineer C60671

DRAWN BY: ETL NO. 202.3

SIDEWALK SECTION

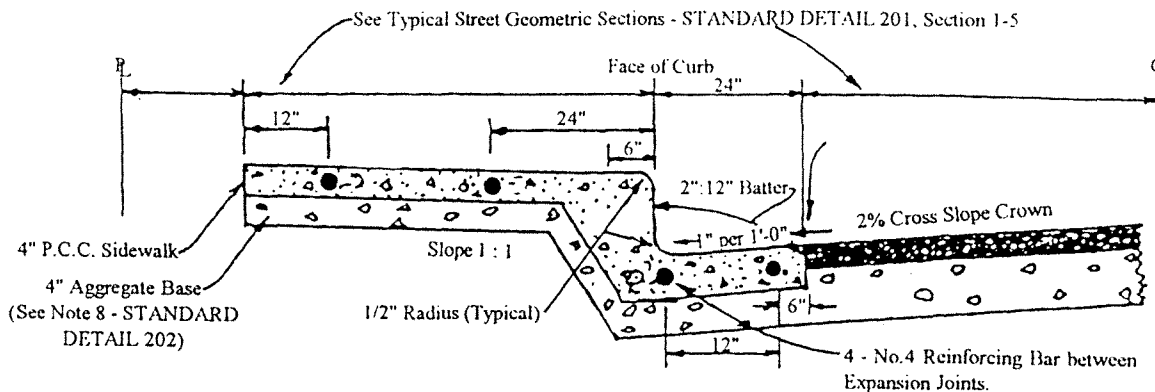

DRIVEWAY SECTION

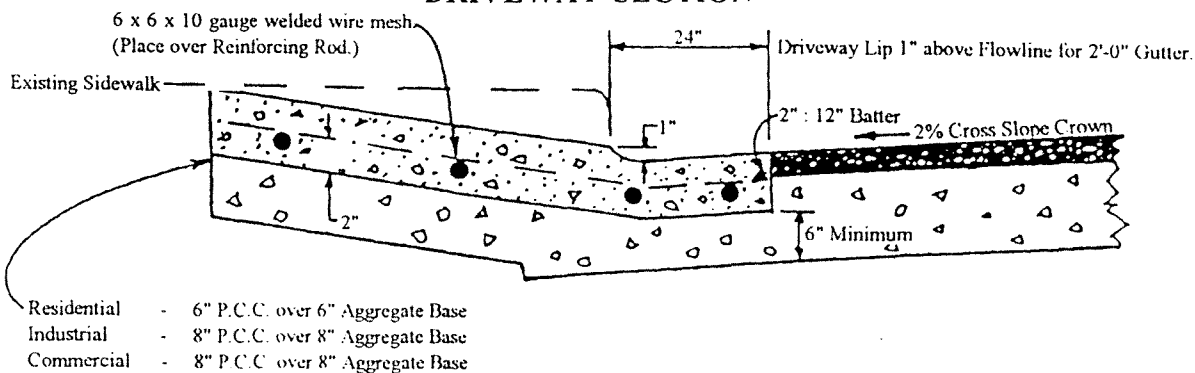

RESIDENTIAL DRIVEWAY

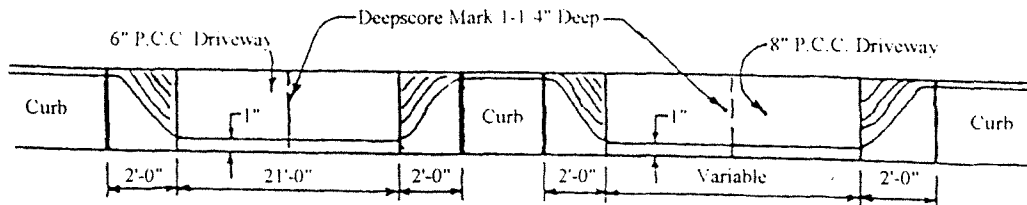

1/4" Expansion Joint each end of Driveway
(See STANDARD DETAIL 202 Note 5)

COMMERCIAL DRIVEWAY

CITY OF PETALUMA
Department of Engineering

22 Bassett Street - Petaluma California 94952
707 778 4304 - Fax 707 778 4433

Approved By

Thomas S. Harris

Thomas S. Harris - R.C.E. 2236

Standard Details
**CURB, GUTTER
SIDEWALK
DRIVEWAY**
X-Section

Drawn by

Butch Smith

Scale:
N T S

Date

February 9th 1997 (Rev)

File Number

SEE STANDARD DETAIL 203



Page

203

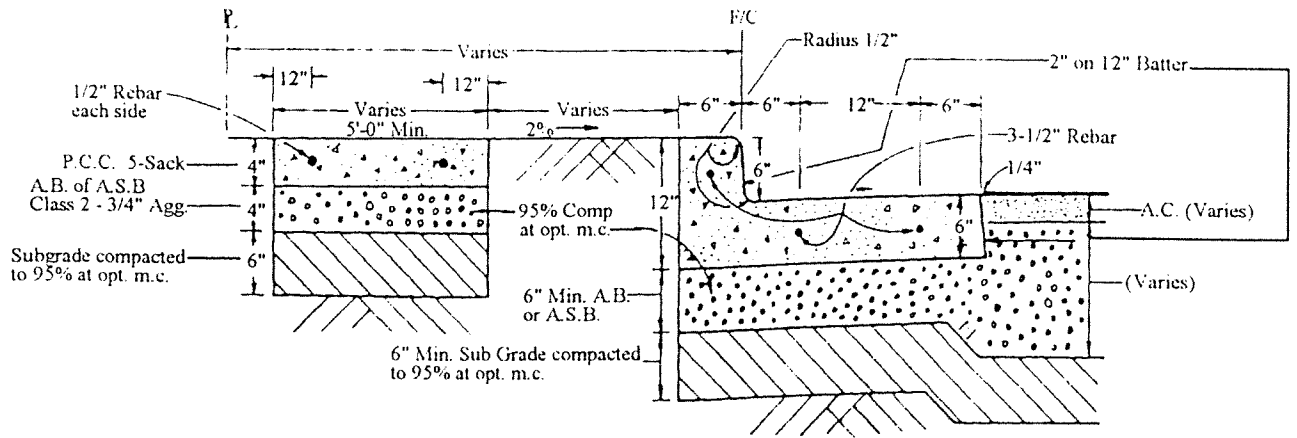

SIDEWALK, CURB AND GUTTER SECTION WITH PLANTER STRIP "NEW"

"New" curb and gutter and or driveway approach as per City Standard Detail.

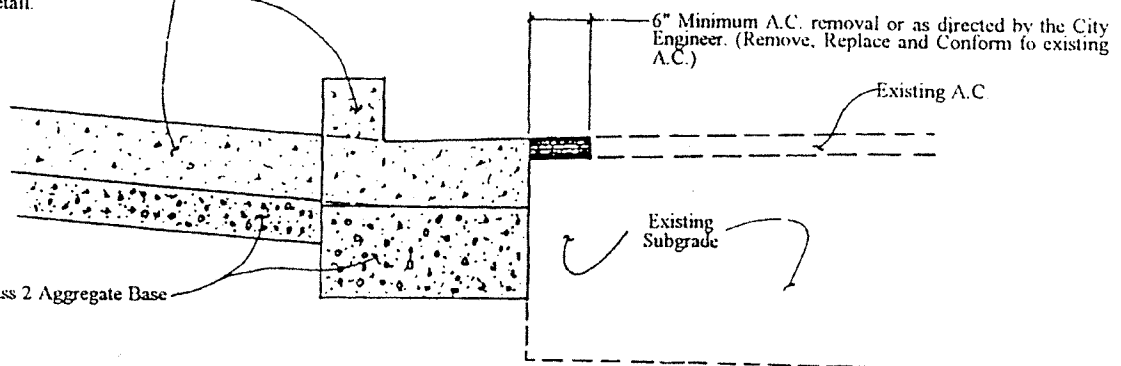

STREET CONFORM DETAIL AT NEW CURB AND GUTTER OR DRIVEWAYS

NOTES:

LANDSCAPED AREAS
Try to save all plants, plants damaged or removed by the contractor shall be replaced "in Kind" at the contractor's expense.

For additional details, See 1984 CALTRANS Standard Plans, Page 85 and 86, drawings N8B and N8C.

1. Expansion joints are required at 60'-0" intervals with 3 each 1/2" diameter Rebar Dowels.
2. Scarify all subgrade and compact to 95% at opt. m.c.
3. Compact A.S.B. or A.B. to 95% at optimum moisture content.
4. Refer to Sidewalk Section.

For expansive soils See City Standard Detail Specification No. 41 paragraph 4102.2 relative compaction

Contractor must remove a minimum of 6" of A.C. or more at the discretion of the Director of Engineering to form for curb and gutter or Driveway approach.

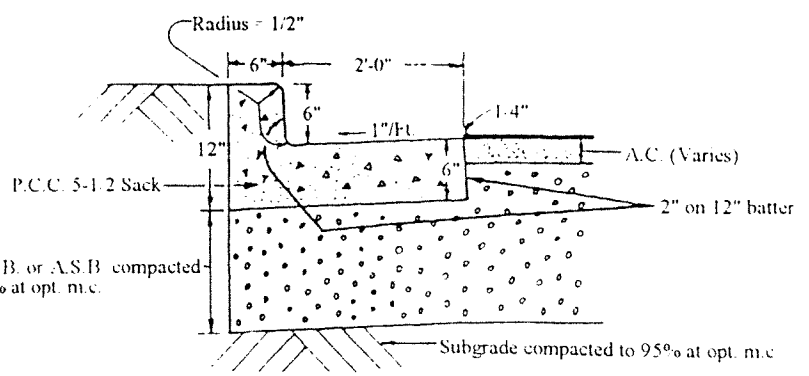

P.C.C. PLACEMENT BY EXTRUSION MACHINE

<p>CITY OF PETALUMA Department of Engineering 22 Bassett Street Petaluma California 94952 707 778 4304 Fax 707 778 4437</p> <p>Approved By <i>Thomas A. Haggis</i> Thomas A. Haggis R.C.E. #2566</p>	<p>Standard Details MISC. "NEW" CONSTRUCTION Sections</p>	<p>Drawn By Butch Smith Scale N. T. S. Date February 9th 1998 (Rev.) File Number Std Det SSD00000 201 2 61 2</p>
		 Page 2 of 3

C2AB = CLASS 2 AGGREGATE BASE. REFER TO CITY STANDARD 202, GENERAL NOTE 8.

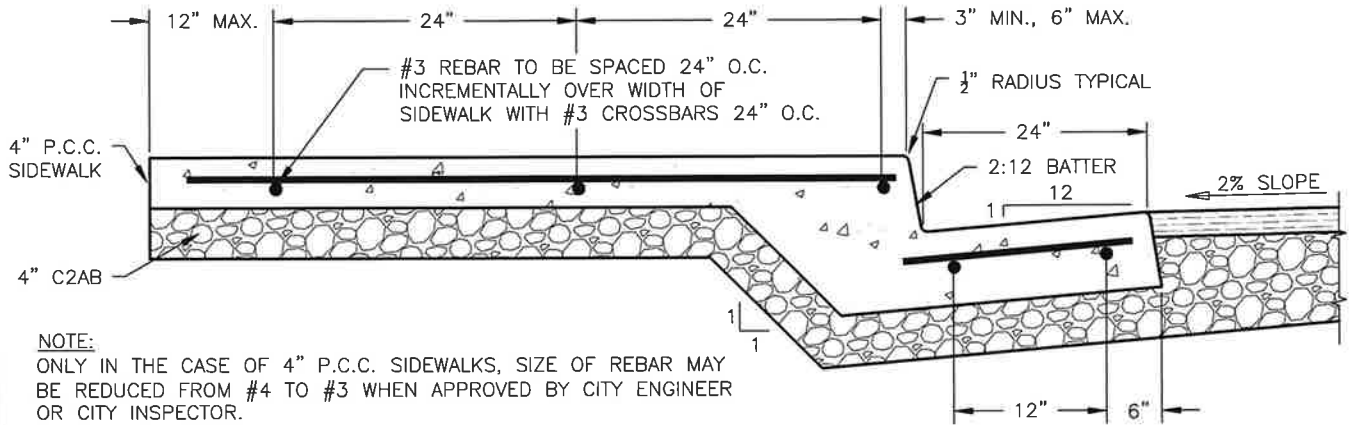

NOTE:
 ONLY IN THE CASE OF 4" P.C.C. SIDEWALKS, SIZE OF REBAR MAY BE REDUCED FROM #4 TO #3 WHEN APPROVED BY CITY ENGINEER OR CITY INSPECTOR.

SIDEWALK SECTION

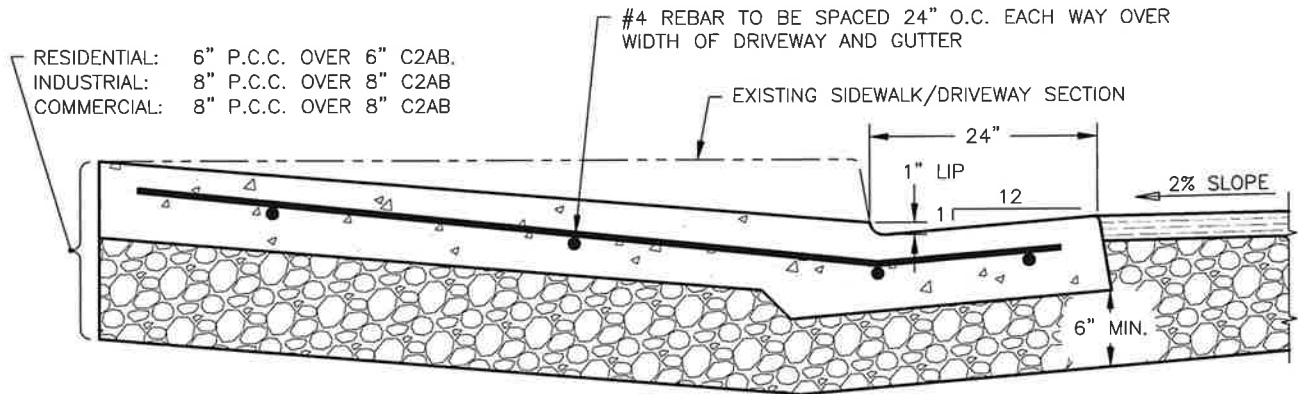

RESIDENTIAL: 6" P.C.C. OVER 6" C2AB.
 INDUSTRIAL: 8" P.C.C. OVER 8" C2AB
 COMMERCIAL: 8" P.C.C. OVER 8" C2AB

DRIVEWAY SECTION

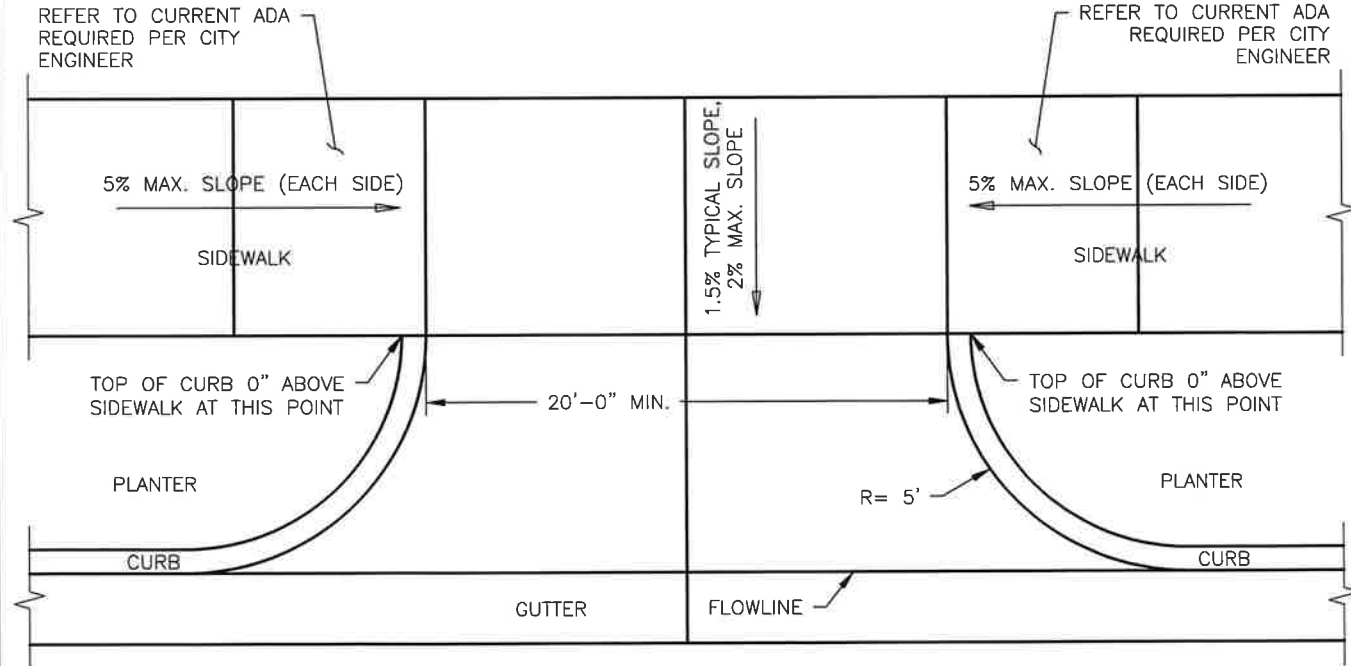

COMMERCIAL DRIVEWAY



CITY OF PETALUMA
PUBLIC WORKS & UTILITIES
 UTILITIES DIVISION
 202 N. McDOWELL BLVD. TEL. 707-778-4546
 PETALUMA, CALIFORNIA 94954 FAX. 707-778-4508

STANDARD DETAILS
CURB, GUTTER
SIDEWALK, DRIVEWAY

DATE: JUNE 2024 SCALE: N.T.S.
 APPROVED BY: *[Signature]*
 Kent R. Carolhers, P.E. City Engineer C60671
 DRAWN BY: ETL NO 203.1

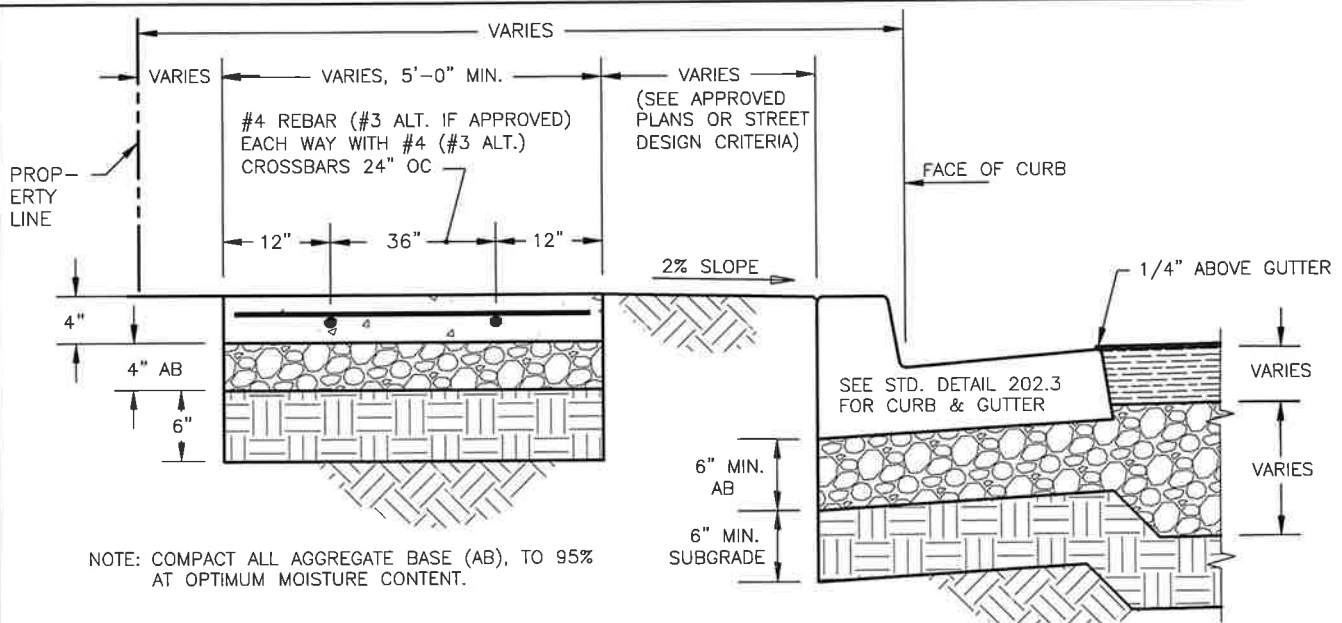

SIDEWALK, CURB AND GUTTER SECTION WITH PLANTER STRIP "NEW"

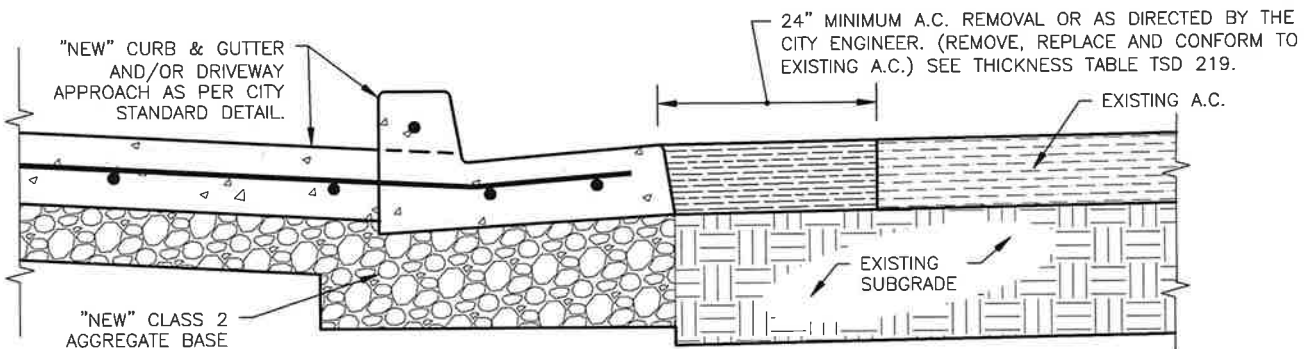

STREET CONFORM DETAIL AT NEW CURB AND GUTTER OR DRIVEWAY

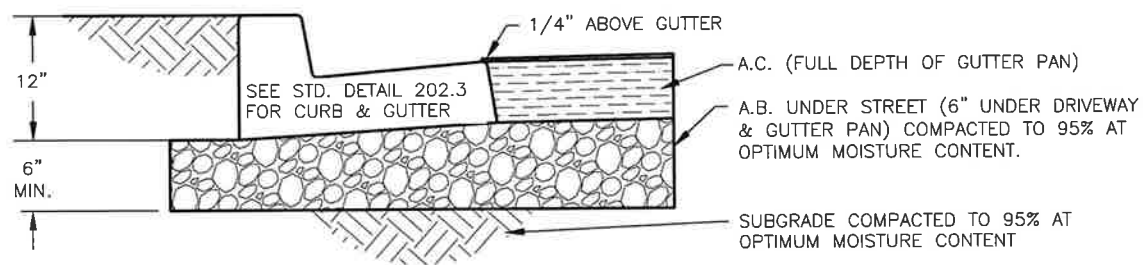

P.C.C. PLACEMENT BY EXTRUSION MACHINE

NOTES:

1. WHEN WORK MUST BE DONE IN LANDSCAPED AREAS, SAVE ALL PLANTS. PLANTS DAMAGED OR REMOVED BY CONTRACTOR SHALL BE REPLACED "IN KIND" AT CONTRACTOR'S EXPENSE.
2. EXPANSION JOINTS ARE REQUIRED AT 60'-0" INTERVALS WITH 3 EACH 1/2" DIAMETER REBAR DOWELS AND CROSSBARS AT 24" SPACING.
3. SCARIFY ALL SUBGRADE AND COMPACT TO 95% AT OPTIMUM MOISTURE CONTENT.
4. COMPACT AB TO 95% AT OPTIMUM MOISTURE CONTENT.
5. REFER TO SIDEWALK SECTION.

FOR EXPANSIVE SOILS SEE CURRENT CITY OF PETALUMA STREET CONSTRUCTION DETAIL SPECIFICATION, PARAGRAPH 2.2, "RELATIVE COMPACTION".
 CONTRACTOR MUST REMOVE A MINIMUM OF 24" OF AC AT THE DISCRETION OF THE CITY ENGINEER--TO CONFORM FOR CURB AND GUTTER OR DRIVEWAY APPROACH.



CITY OF PETALUMA
PUBLIC WORKS & UTILITIES
 UTILITIES DIVISION
 202 N. McDOWELL BLVD. TEL. 707-778-4546
 PETALUMA, CALIFORNIA 94954 FAX. 707-778-4508

STANDARD DETAILS
MISC. "NEW"
CONSTRUCTION
SECTIONS

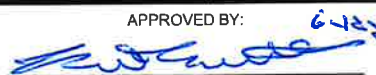
DATE: JUNE 2024	SCALE: N.T.S.
APPROVED BY: 	
Kent R. Carothers, P.E. City Engineer C60671	
DRAWN BY: ETL	NO. 203.2

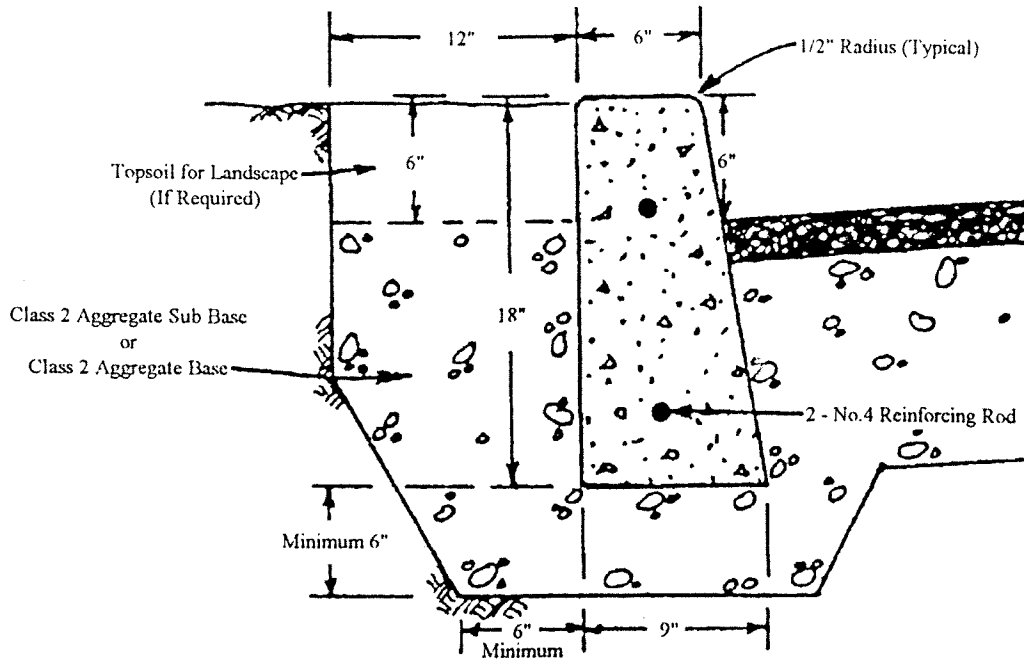

VERTICAL CURB

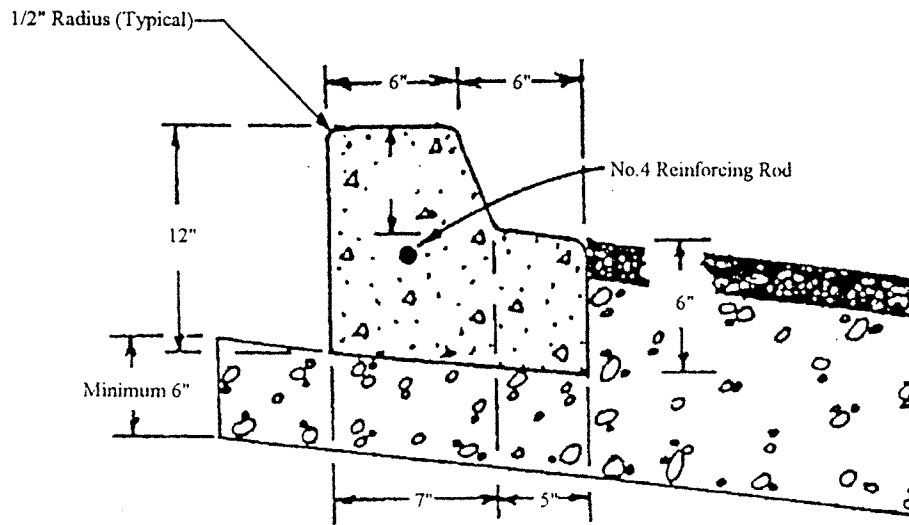

CURB AND FALL AWAY GUTTER

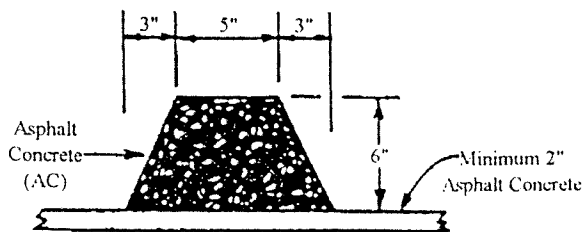

ASPHALT CONCRETE CURB

NOTE:

Asphalt concrete curb to be placed by an acceptable extrusion machine only.

CITY OF PETALUMA
Department of Engineering

22 Bassett Street - Petaluma California 94952
707 778 4304 - Fax 707 778 4437

Approved By

Thomas S. Hargis

Thomas S. Hargis R.C.E. 22366

Standard Details
CURB
&
GUTTER

Drawn By
Butch Smith

Scale
N T S

Date
September 4th 1996

File Number
Std Det SSS0000 204 2 of 2



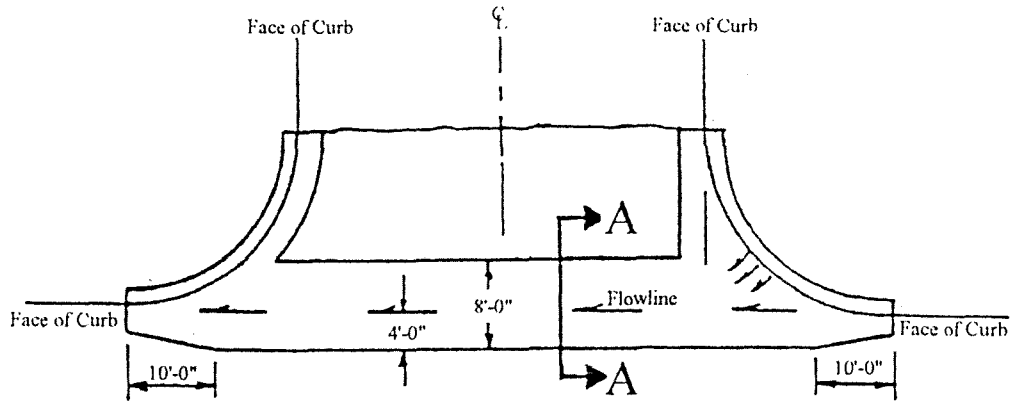

VALLEY GUTTER DETAIL

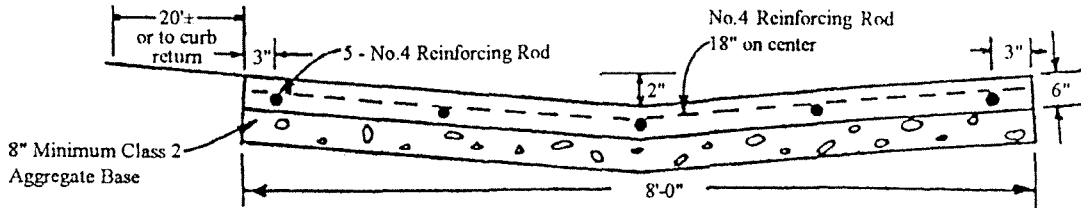

SECTION A-A
STANDARD VALLEY GUTTER DETAIL

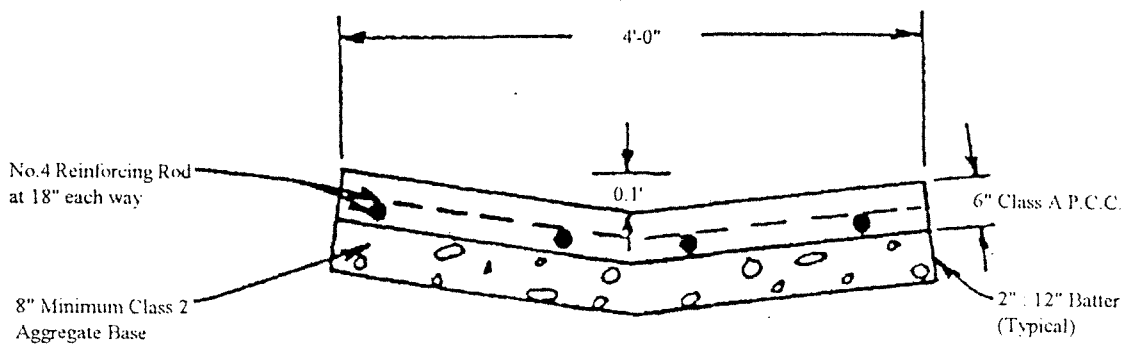

VALLEY GUTTER MINOR CUL-DE-SAC

CITY OF PETALUMA
Department of Engineering

22 Bassett Street - Petaluma California 94952
707 778 4304 - Fax 707 778 4437

Approved By

Tom Harris

Thomas S. Harris - C.E. 22366

Standard Details
VALLEY
GUTTER

Drawn by
Butch Smith

Scale

N. T. S.

Date

September 4th 1996

File Number

Std. Det. SSS0000 205



Page

205

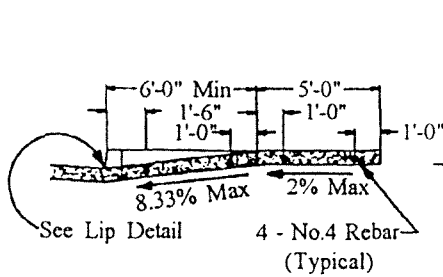
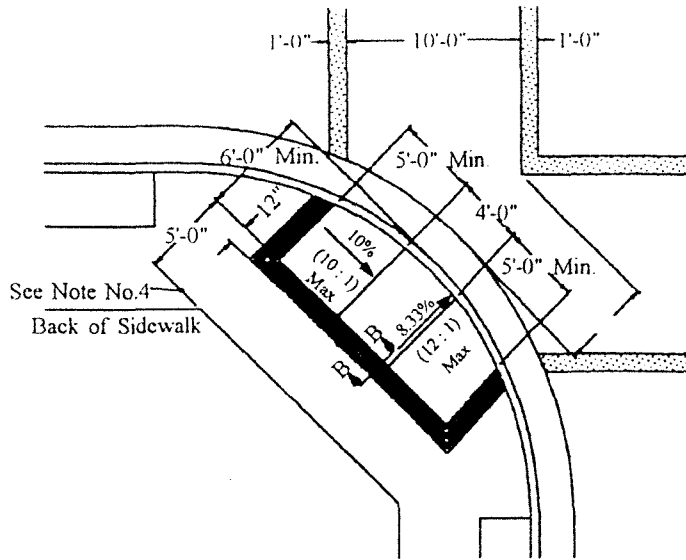

RAMP DETAIL

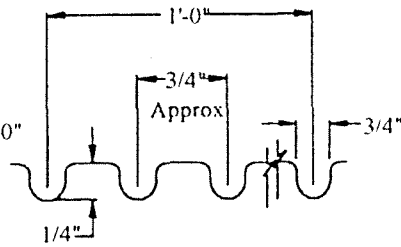

SECTION B - B

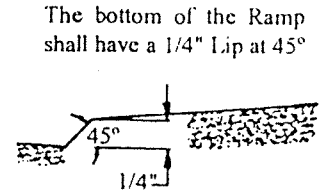

LIP DETAIL

NOTE:

1. Design shall conform to these requirements except as otherwise approved by the Director of Engineering.
2. For subdivisions where sidewalks are not required for street improvement, curb depressions for curb ramps shall be omitted.
3. The surface of each curb ramp shall be slip resistant and shall be of contrasting finish for that of the adjacent sidewalk.
4. Type "B" or "C" ramp to be used in situations when 5'-0" minimum landing can not be obtained.
5. Sidewalk and ramp thickness shall be 4" of P.C.C. with four No 4 rebar continuous over 4" of Class 2 A.B. compacted to 95%.
6. If curb exists, 12" dowels are required at 4'-0" on center between existing curb and new construction.

<p>CITY OF PETALUMA Department of Engineering 22 Bassett Street - Petaluma California 94952 707 778-4304 - Fax 707 778-4437</p> <p>Approved By <i>Thomas S Hargis</i> Thomas S Hargis - R.C.E. 22366</p>	<p>Standard CURB RAMP TYPE - A Detail</p>	<p>Drawn By Butch Smith Scale N T S Date February 9th 1998 (Rev.) File Number Std. Det. SSD0000.206 1 of 3</p>
		 Page 206

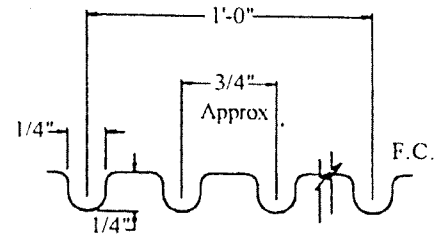
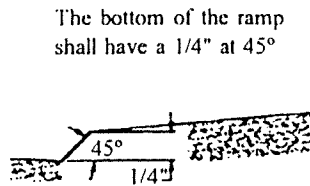
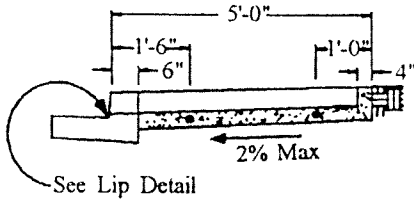
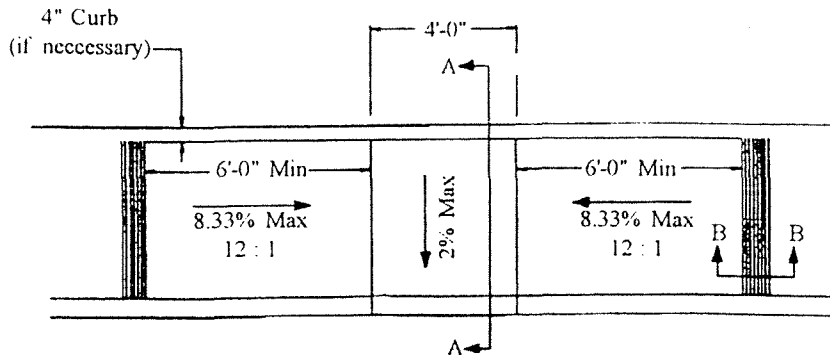

SECTION A - A

LIP DETAIL

SECTION B - B

NOTE:

1. Design shall conform to these requirements except as otherwise approved by the Director of Engineering.
2. For subdivisions where sidewalks are not required for street improvements, curb depressions for curb ramps shall be omitted.
3. The surface of each curb ramp shall be slip resistant and shall be of contrasting finish from that of the adjacent sidewalk.
4. Type "B" or "C" ramp to be used in situations when 5'-0" minimum landing can not be obtained.
5. Sidewalk and ramp thickness shall be 4" of P.C.C. with two No.4 rebar continuous over 4" of Class 2 A.B. compacted to 95%.
6. If curb exists, 1/2" dowels are required at 4'-0" on center between existing curb and new construction.

CITY OF PETALUMA
Department of Engineering

22 Bassett Street - Petaluma California 94952
707 778 4304 - Fax 707 778 4437

Approved By

Thomas S. Hargis
Thomas S. Hargis - R.C. 222366

Standard
CURB RAMP
TYPE - B
Detail

Drawn By
Butch Smith

Scale
N. T. S.

Date
February 9th 1998 (Rev.)

File Number
Std. Det. SSD 0000 206 2 of 3



Page
206

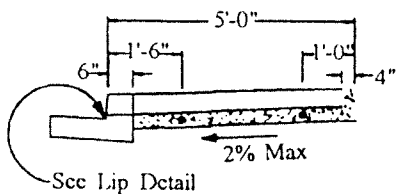
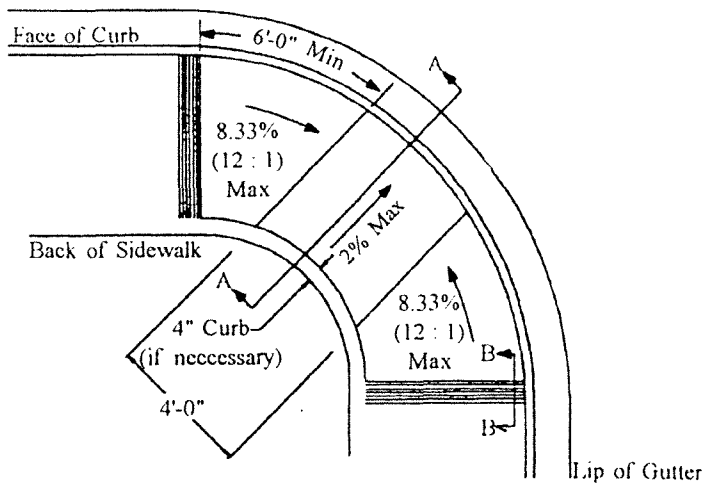

SECTION A - A

Lip bottom of the ramp shall have a 1/4" lip at 45°

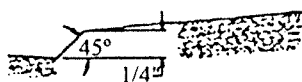

LIP DETAIL

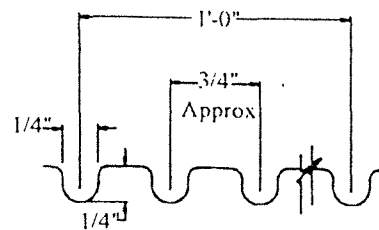

SECTION B - B

NOTE:

1. Design shall conform to these requirements except as otherwise approved by the Director of Engineering.
2. For subdivisions where sidewalks are not required for street improvements, curb depressions for curb ramps shall be omitted.
3. The surface of each curb ramp shall be slip resistant and shall be of contrasting finish from that of the adjacent sidewalk.
4. Type "B" or "C" ramp to be used in situations when 5'-0" minimum landing can not be obtained.
5. Sidewalk and ramp thickness shall be 4" P.C.C. with two No. 4 rebar continuous over 4" of Class 2 A.B. compacted to 95%.
6. If curb exists, 12" dowels are required at 4'-0" on center between existing curb and new construction.

CITY OF PETALUMA
 Department of Engineering
 22 Bassett Street - Petaluma California 94952
 707 778 4304 - Fax 707 778 4437
 Approved By
Thomas S. Hargis
 Thomas S. Hargis - R.C.E. 22366

Standard
CURB RAMP
TYPE - C
 Detail

Drawn By
 Butch Smith
 Scale
 N T S.
 Date
 February 9th 1998 (Rev.)
 File Number
 Std Det. SSD0000.206 3 of 3



Page
 206

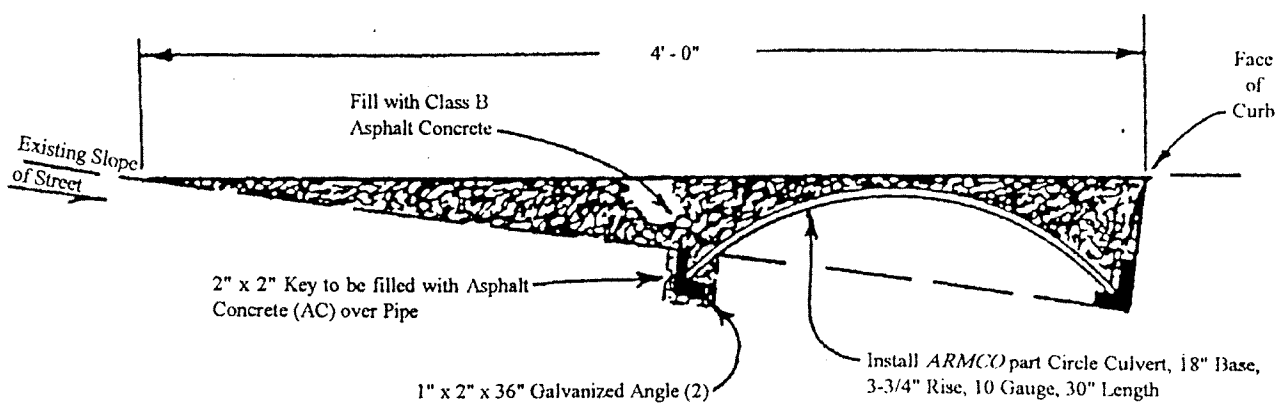

PLAN VIEW

CITY OF PETALUMA
 Department of Engineering
 22 Bassett Street - Petaluma California 94952
 707 778 4504 Fax 707 778 4437
 Approved By
John Nargis
 Thomas S. Nargis R.C.E. 22366

Standard Details
**DRIVEWAY
 CULVERT**
 High Crown Streets

Drawn By
Butch Smith
 Scale
N.T.S.
 Date
September 4th 1996
 File Number
 Std. Det. 558-01-007

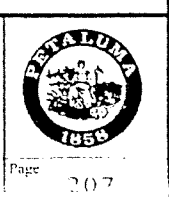

NOTE:

Use a Standard 30" STOP Sign with 8" Minimum letters
 Use "SCOTCHLITE" reflective State Hwy. Sign R1

See City Standard Detail
 No. 208 Sheet 3 of 3

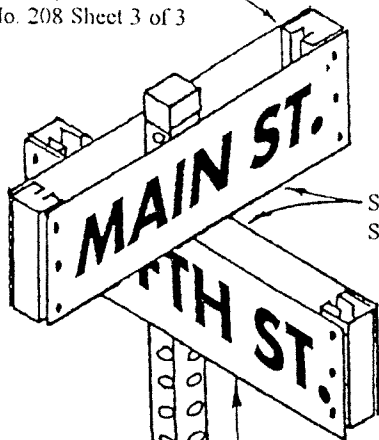

Street Names Sign to have 4" Letters.
 Sign Dimensions to be 6" x 24" Minimum



Standard STOP Sign and combination
 STOP and Street Sign to be located 18"
 from Face of Curb.

Standard Street Sign to be located of back
 edge of Sidewalk.

Insert Sign Tubing into Sleeve 8"

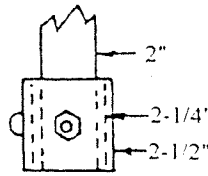
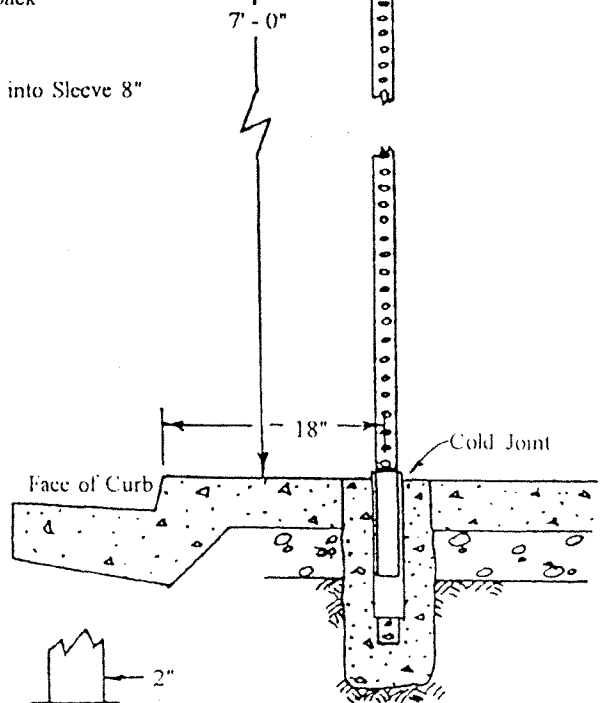
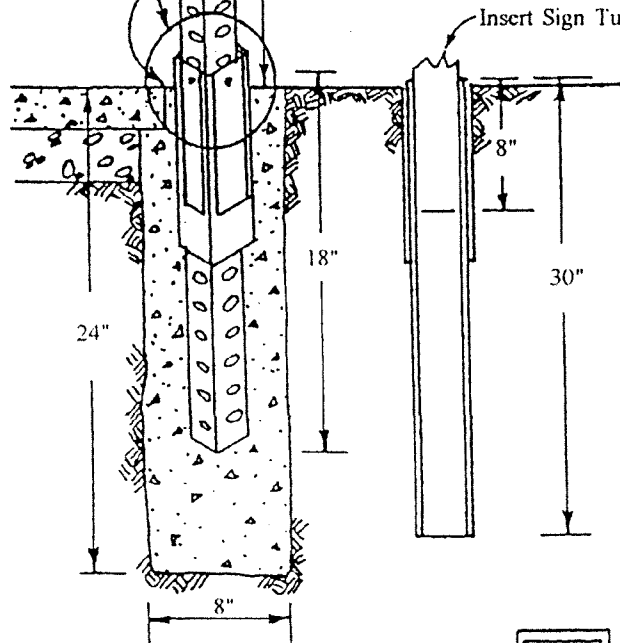

See City Standard Detail No. 208,
 Sheet 2 of 3 for Specific Details
 and Notes.

DETAIL "A"

CITY OF PETALUMA
 Department of Engineering

22 Bassett Street - Petaluma California 94952
 707 778 4304 - Fax 707 778 4413

Approved By

John Hargin
 Thomas S. Hargin, P.E., C.E.

Standard Details
STREET
 &
STOP SIGNS

Drawn By
Butch Smith

Scale
N T S

Date
September 4th 1996

File Number
20100-SSS0000 208



Sheet 2 of 3

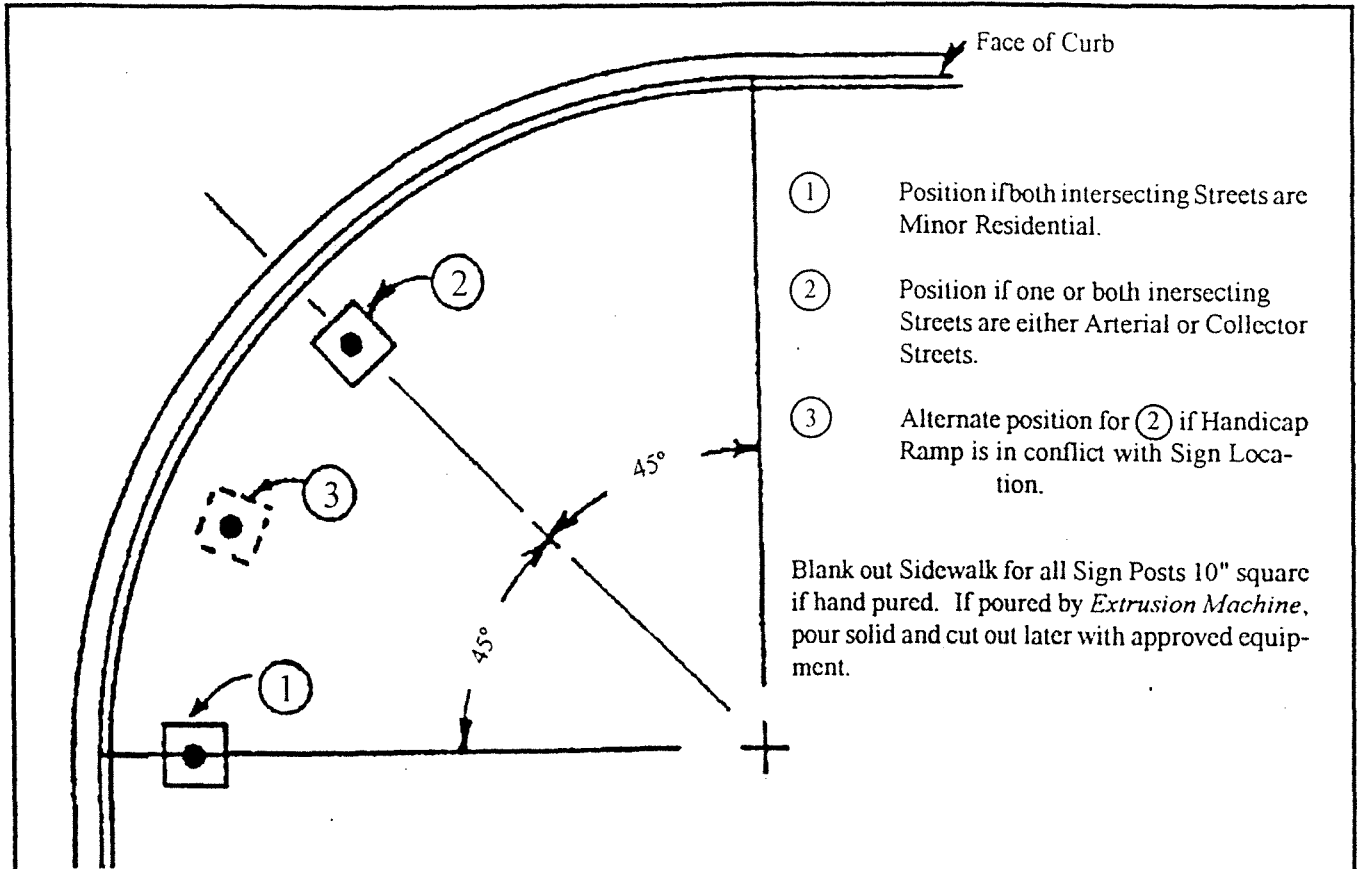

NOTE:

- 1 The Street name and Stop signs shall consist of the specified post, base, street signs, and mounting completely installed.
BASE: A concrete base 8" in diameter and 26" deep shall be constructed around each post, the top edge being flush with the back of sidewalk and the bottom 2" below the end of the post.
POST: The post shall be *TELESPAR 20F12* Green or equal. 2" telescoping square tubing, 12-Gauge, Galvanized finish, painted Green, 7/16" diameter holes at 1" on center four sides. Pole to be 11'-6" in length with one end finished to receive mounting cap and fittings.
SIGN: All Signs shall be *SCOTCHLITE* reflective or equal, mounted on aluminum, minimum thickness of 0.080". Letters shall be Silver mounted on Green.

2. If Post to be set in concrete:
 1 - 18" x 2-1/4" square tubing Anchor Base
 1 - 18" x 2-1/2" square tubing Support Sleeve.
 If Post is installed in Native Soil:
 1 - 30" x 2-1/4" square tubing Anchor Base.
 1 - 30" x 2-1/2" square tubing Support Sleeve.

3. Generally, Regulator Signs (STOP, Speed Limit, Etc.) will be located 18" behind Face of Curb. Informational Signs (Curve Arrows, Pavement Narrows, Etc.) usually are located behind the Sidewalk.

- 4 All Signs shall conform to the current State of California, Department of Transportation Traffic Manual and these Standard Details

CITY OF PETALUMA
 Department of Engineering
 22 Bassett Street - Petaluma California 94952
 707 778 4304 - Fax 707 778 4437

Approved By:

 Thomas S. Hargis - PCE 22366

Standard Details
STREET
 &
STOP SIGNS
 Location and Notes

Drawn By:
 Butch Smith
 Scale:
 N. T. S.
 Date:
 October 30th 1996
 File Number:
 Std Det. SSD000 208 2 of 3

Page 208

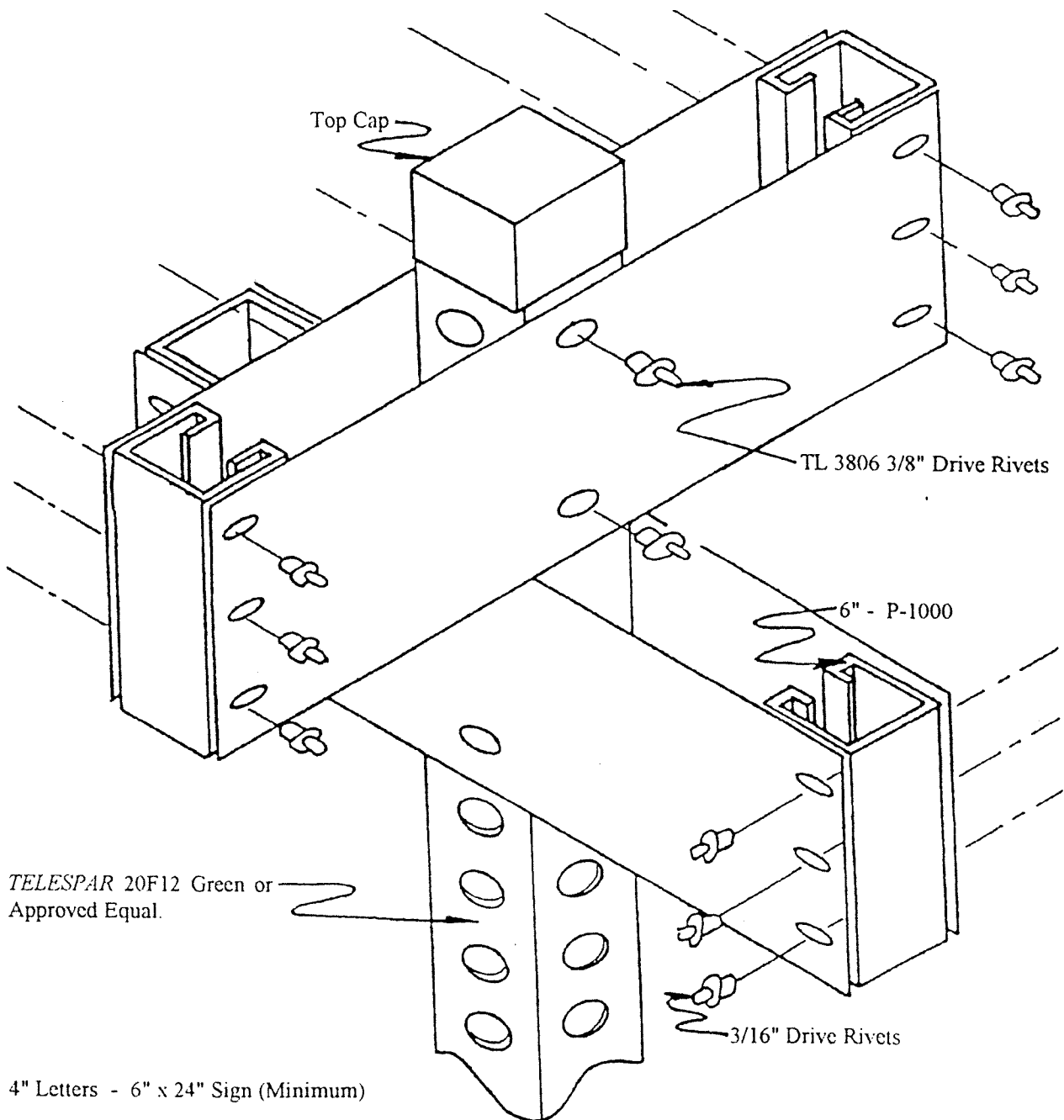

TELESPAR 20F12 Green or
Approved Equal.

4" Letters - 6" x 24" Sign (Minimum)

All Signs shall be *SCOTCHLITE* Reflective or equal mounted on Aluminum,
Minimum thickness 0.080" Letters shall be Silver mounted on Green back-
ground

<p>CITY OF PETALUMA Department of Engineering 22 Bassett Street - Petaluma, California 94952 707 778-4304 - Fax 707 778-4157</p> <p>Approved By <i>Thomas S. Harris</i> Thomas S. Harris - R.C.E. 22360</p>	<p>Standard Details STREET NAME SIGN Detail</p>	<p>Drawn By Butch Smith Scale N T S Date October 30th 1996 File Number Std Det SSD0000 208 1 10 3</p>	 <p>Page 208</p>
--	--	---	---

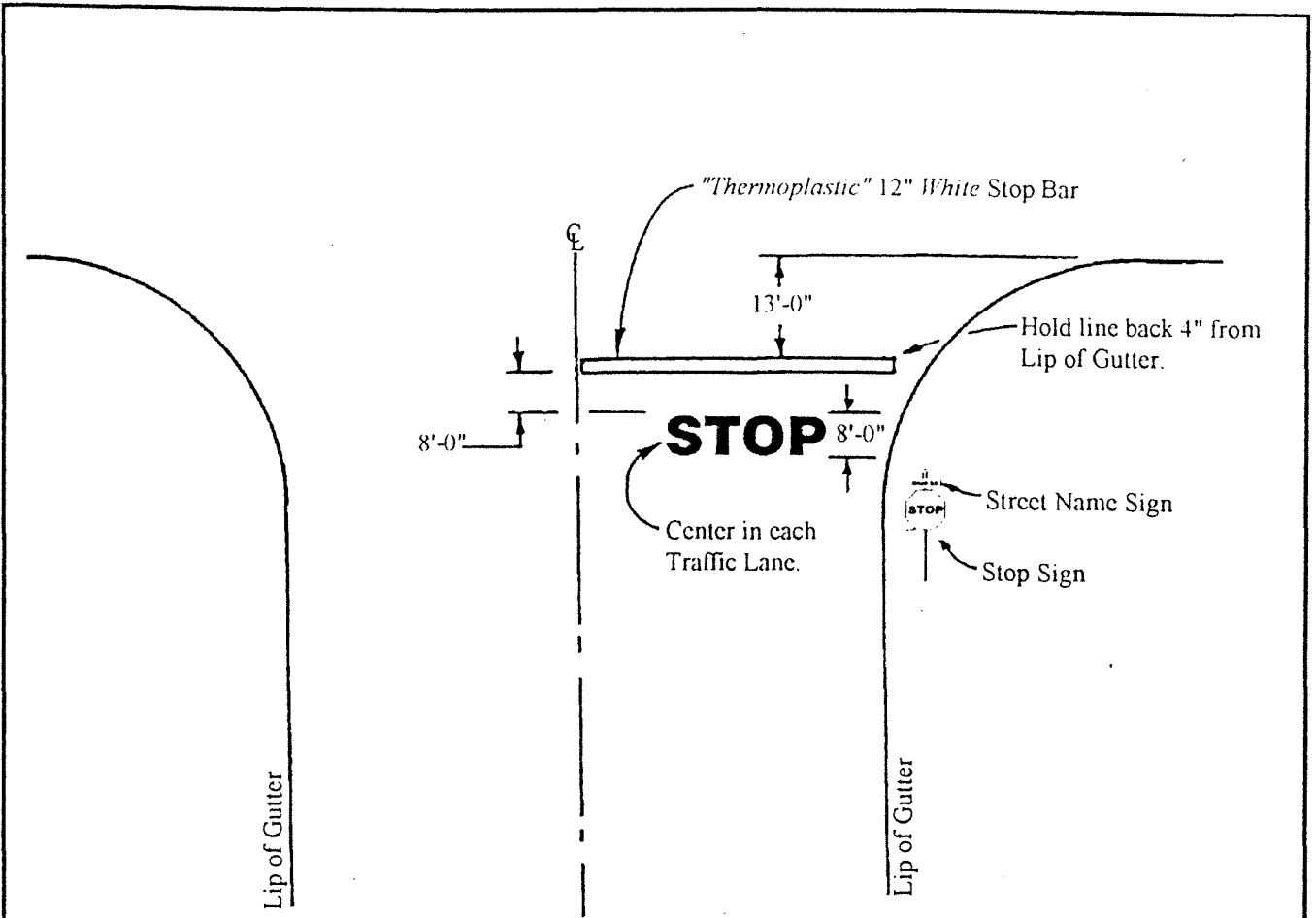

NOTE

1. All intersections designated for STOP signs shall include the "Thermoplastic" STOP and stop bar.
2. STOP Letters shall be "Thermoplastic" using *State of California Department of Transportation* approved stencils. Letters shall be a minimum of 8'-0" in height.

CITY OF PETALUMA
Department of Engineering

22 Bassett Street - Petaluma California 94952
707 778 4304 - Fax 707 778 4457

Approved By

Ed Hargis

Standard Details
STOP BAR
&
STOP WORD
Detail

Drawn by

Butch Smith

Scale

N T S

Date

September 4th 1996

File Number

See Detail 285 for Stop Sign



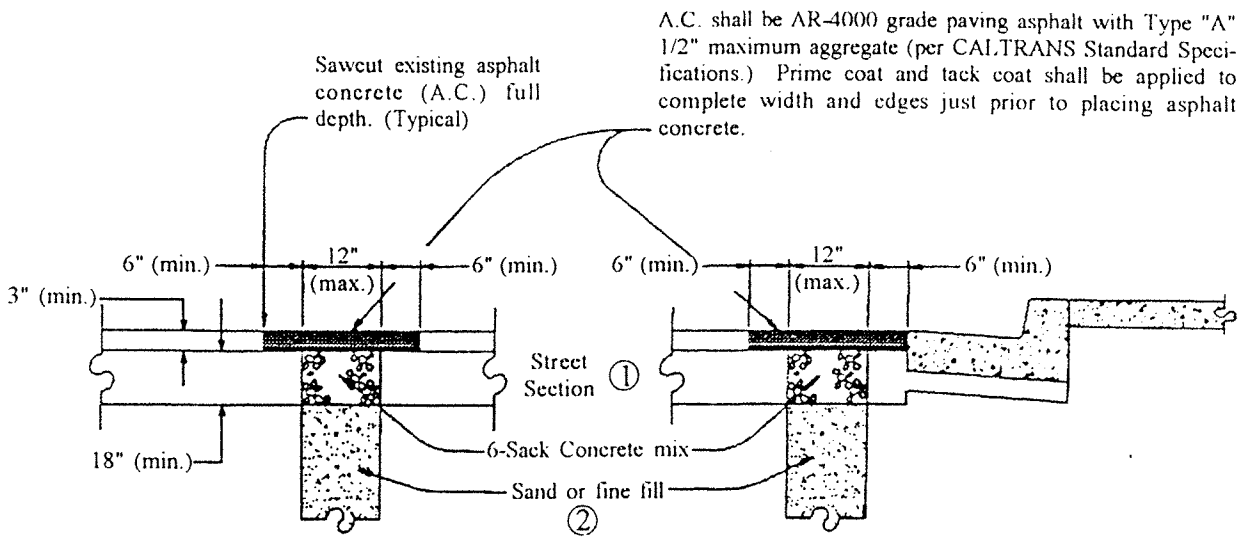

A.C. shall be AR-4000 grade paving asphalt with Type "A" 1/2" maximum aggregate (per CALTRANS Standard Specifications.) Prime coat and tack coat shall be applied to complete width and edges just prior to placing asphalt concrete.

- ① The street structural section shall be a minimum of 3" Asphalt Concrete (A.C.) on 18" of 6-sack concrete mix minimum, to be used as directed by the City Engineer.
- ② Sand slurry backfill per CALTRANS Specification 19-3.062, or controlled density fill of approved mix design may be substituted as authorized by the City Engineer

NOTES:

1. A Street Encroachment Permit will be required for all work within the public right-of-way.
2. All work to be done in accordance with the City of Petaluma Standards and Specifications.
3. Underground service alert (U.S.A.) shall be notified prior to beginning work.
4. All excavations shall conform to the requirements of the State of California Division of Occupational Safety and Health (O.S.H.A.)
5. Bedding for the conduit shall meet the requirements of the utility having jurisdiction or ownership of the conduit.

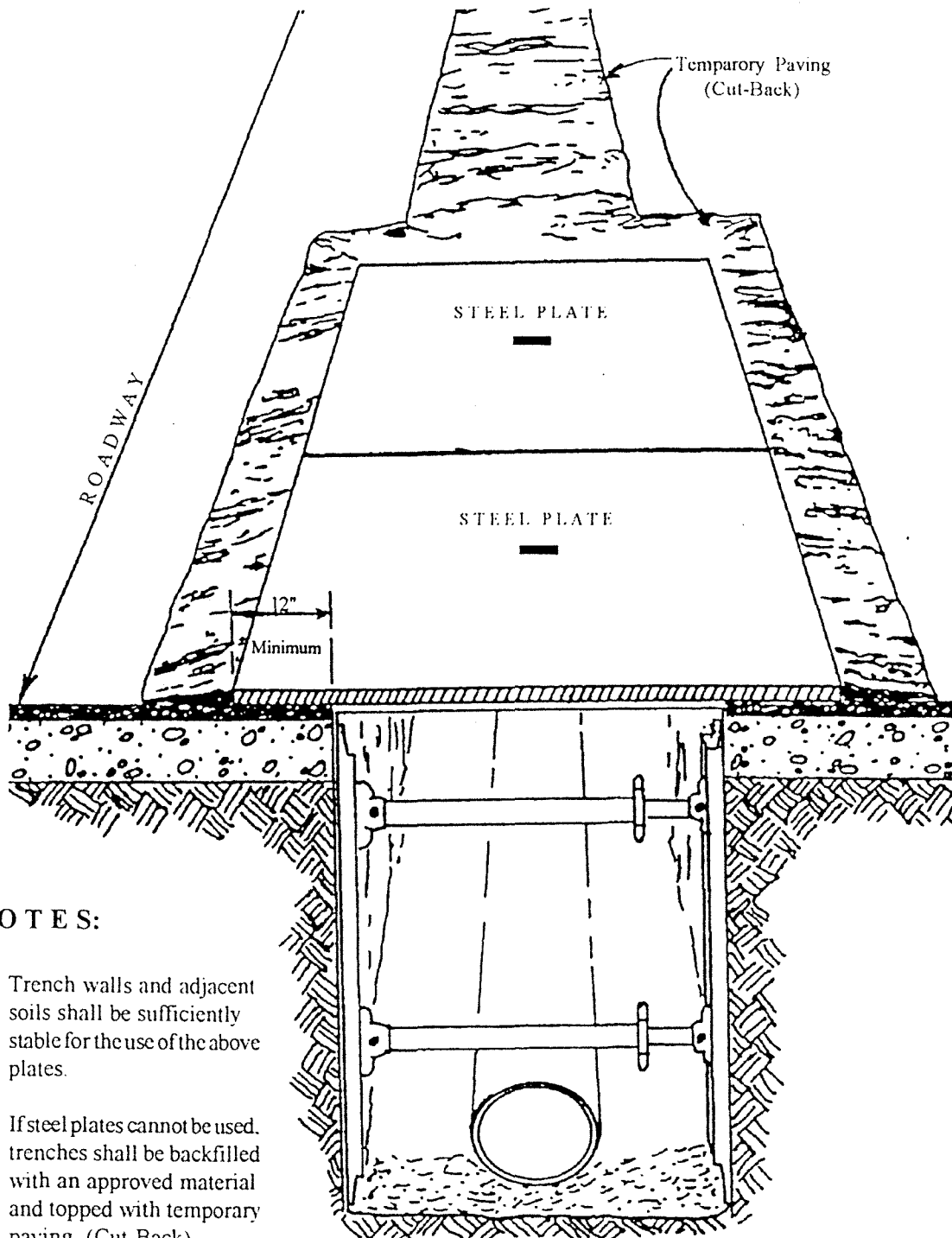

NOTES:

1. Trench walls and adjacent soils shall be sufficiently stable for the use of the above plates.
2. If steel plates cannot be used, trenches shall be backfilled with an approved material and topped with temporary paving. (Cut-Back)

WIDE OF TRENCH	MINIMUM THICKNESS OF STEEL PLATES
1'-0"	1/2"
1'-6"	3/4"
2'-0"	7/8"
3'-0"	1"
4'-0"	1-1/4"

CITY OF PETALUMA
Department of Engineering

22 Bassett Street - Petaluma California 94952
707 778 4304 - Fax 707 778 4413

Approved By
J. A. Hargin
Thomas S. Hargin

Standard Details
TRENCH PLATING
In Streets

Drawn By
Butch Smith

Scale

N T S

Date

October 30th 1996

File Number

SS00000 213



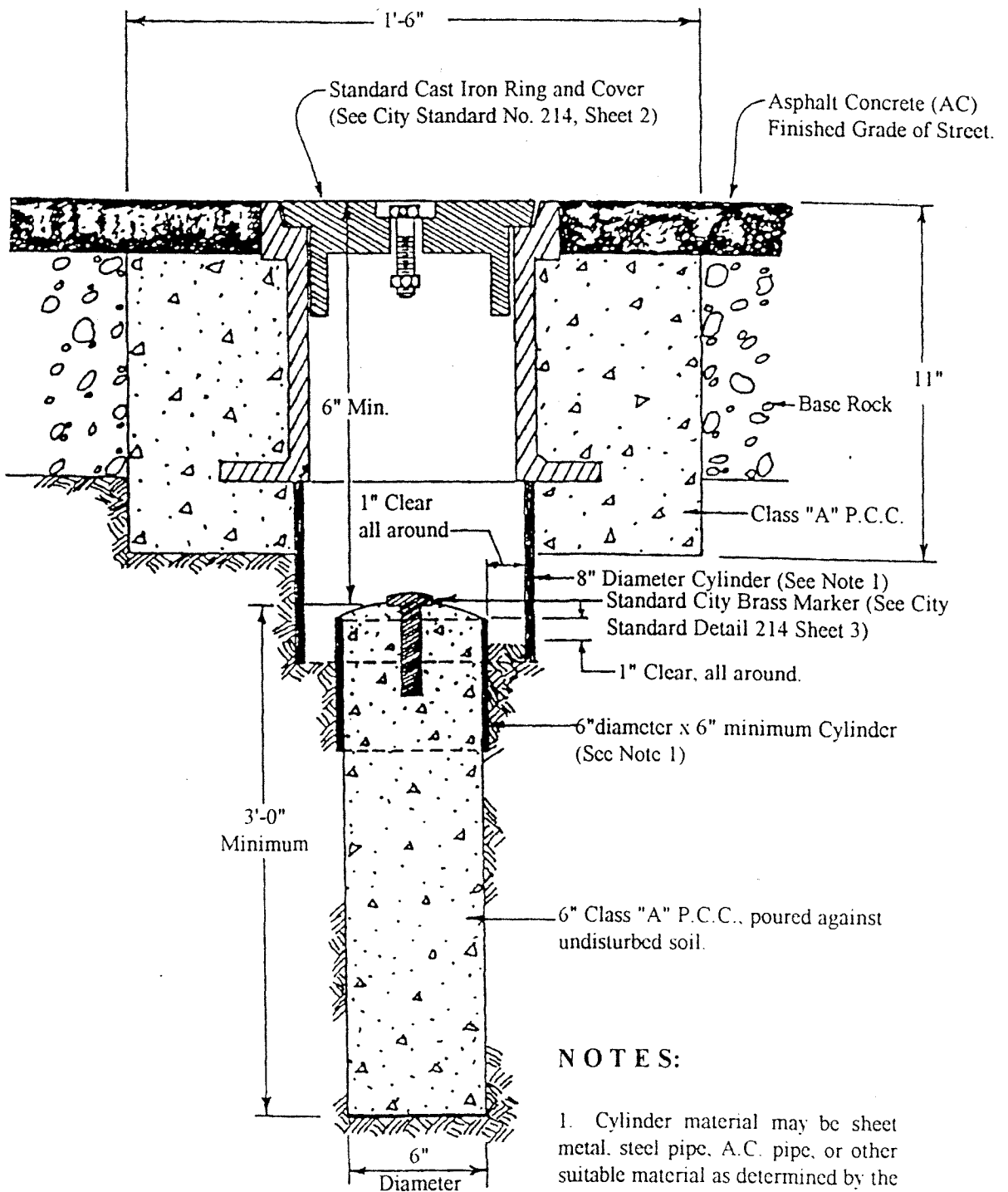

NOTES:

1. Cylinder material may be sheet metal, steel pipe, A.C. pipe, or other suitable material as determined by the City Engineer.

CITY OF PETALUMA
Department of Engineering

22 Bassett Street - Petaluma California 94952
707 778 4304 - Fax 707 778 4437

Approved By

Thomas S. Hargis

Thomas S. Hargis - R.C.E. 22366

Standard Details
**CITY
MONUMENT**
Detail

Drawn By
Butch Smith

Scale

N T S

Date

October 30th 1996

File Number

Std Det. SSD0000 214 1 OF 3



Page

214

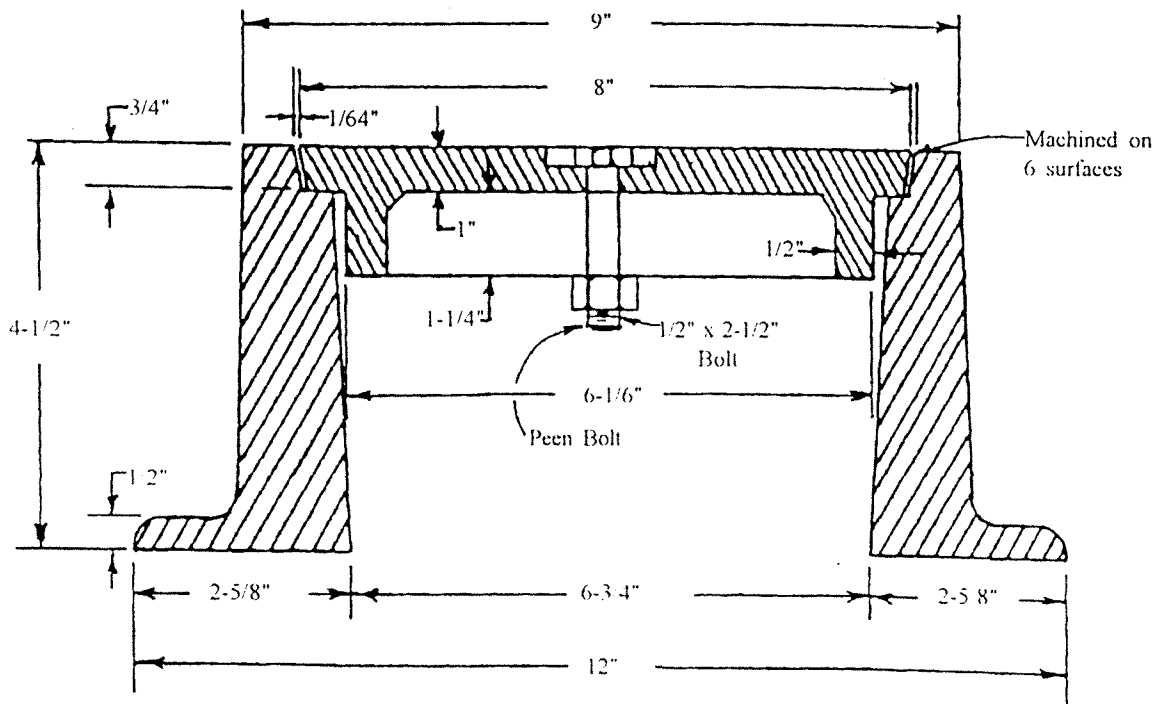
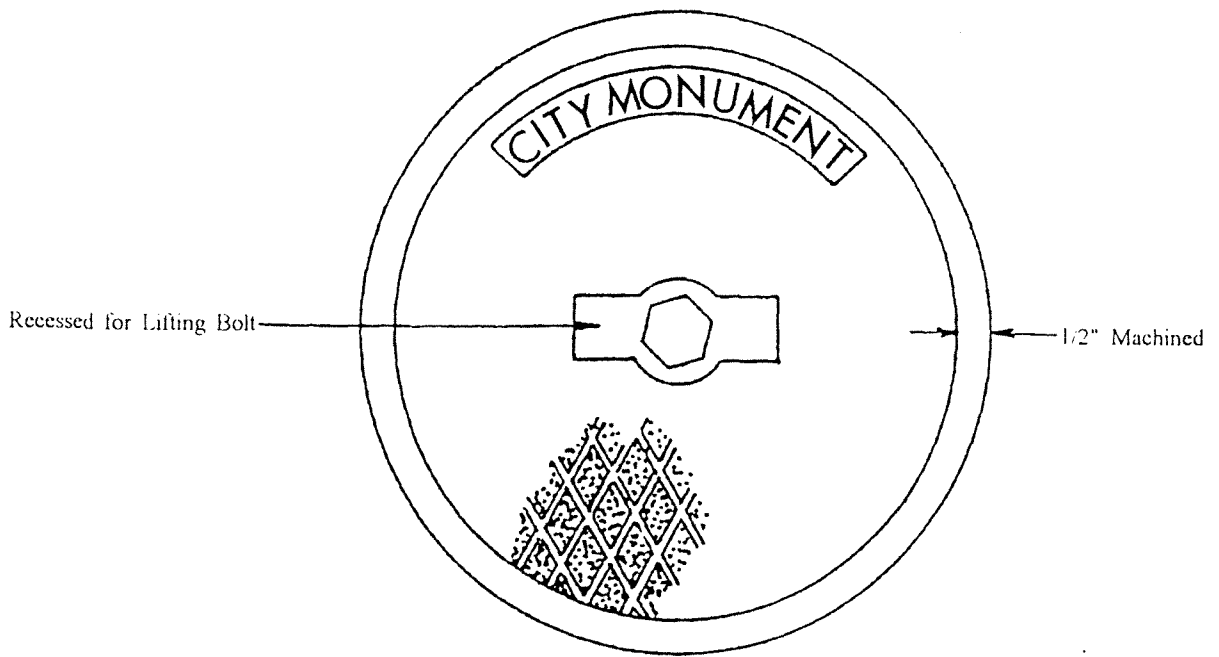

NOTES:

A.S.T.M. Class 30 Iron Castings
to dipped in Asphalt Pain.

APPROVED MONUMENT CASTINGS

Phoenix, No. P-2001-A or P-2001-E
Visco, No. 129
American Brass and Iron Foundry Model No. 5020-21
Artmark Product Company, No. APC-51
Sant Rosa Cast Products, No. sp-51

CITY OF PETALUMA
Department of Engineering

22 Bassett Street - Petaluma California 94952
707 778 1304 - Fax 707 778 1137

Approved By

J. A. Hargis

Electronic Signatures - Not Valid

Standard Details
**CITY
MONUMENT
COVER**

Drawn By
Butch Smith

Scale
N T S

Date
September 6th 1996

File Number

Scale: 1" = 1/2" (SEE DRAWING FOR DETAILS)



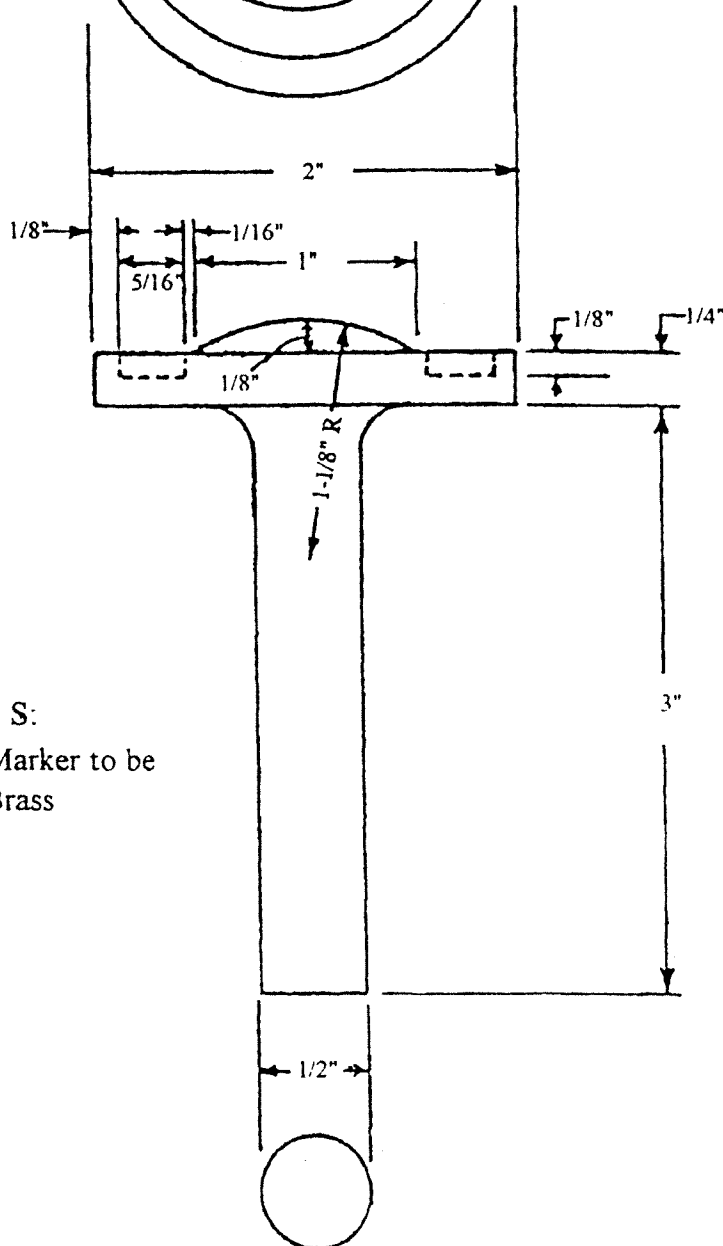
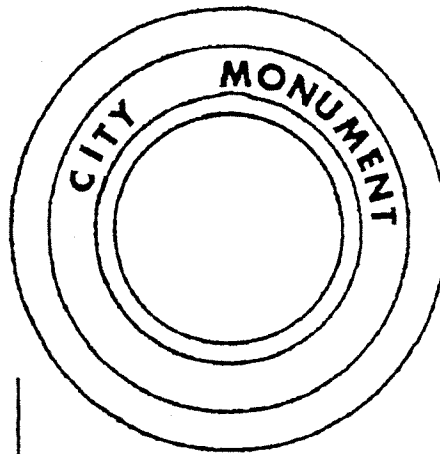

NOTES:
 Survey Marker to be
 Cast in Brass

CITY OF PETALUMA
 Department of Engineering

22 Bassett Street · Petaluma California 94952
 707 778 4304 · Fax 707 778 4437

Approved By
Thomas S. Vargas
 Thomas S. Vargas R.C.E. 22366

Standard Details
**BRASS
 SURVEY
 MARKER**

Drawn By
 Butch Smith

Scale
 N T S

Date
 October 30th 1996

File Number:
 Std Det: SSD000 214 3 of 3



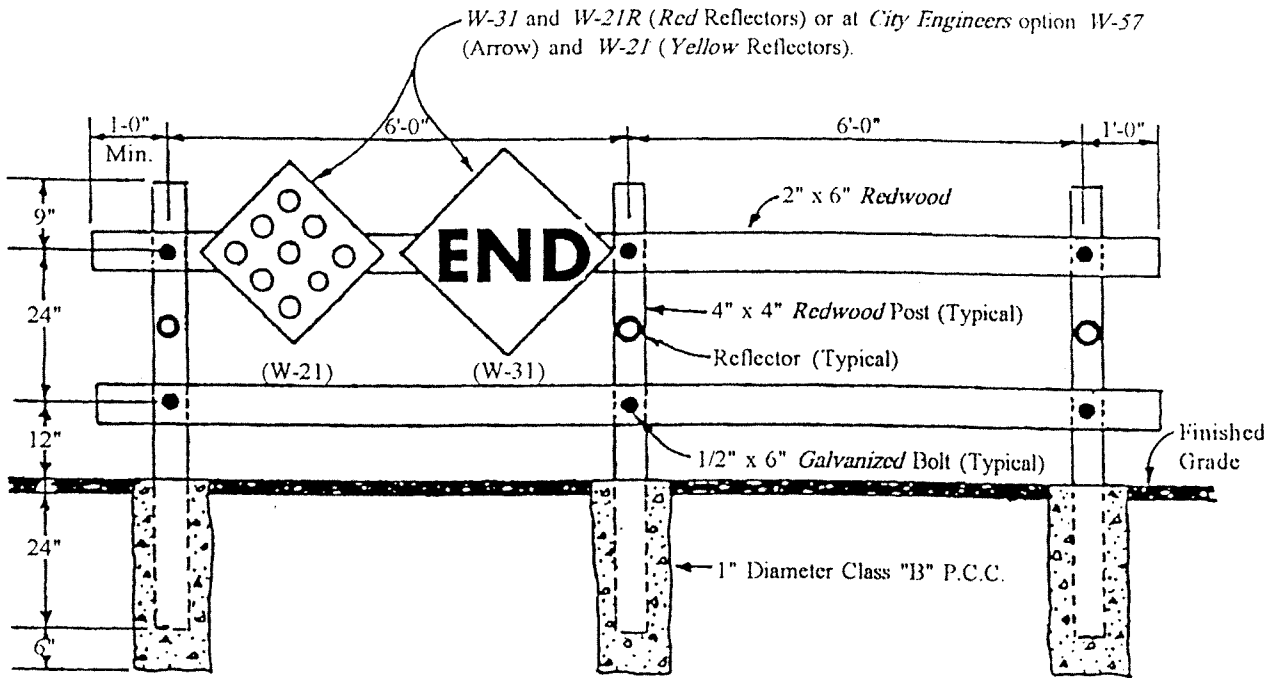

NOTES:

1. The *W-21* to be centered in traffic lane.
2. Two coats of Exterior *White* paint on structure.
3. All bolts, nuts, and washers to be *Galvanized*.
4. Barricade to be placed as shown on plan or as directed by the *City Engineer*.

CITY OF PETALUMA
 Department of Engineering
 22 Bassett Street - Petaluma, California 94952
 707 778 4504 - Fax 707 778 1137

Approved By
Thomas S. Harris
 Thomas S. Harris, R.C.E., P.E.

Standard Details
BARRICADE
 Detail

Drawn By
Butch Smith
 Scale
 N T S
 Date
 September 9th 1996
 File Number
 Std Det SSD0000 215



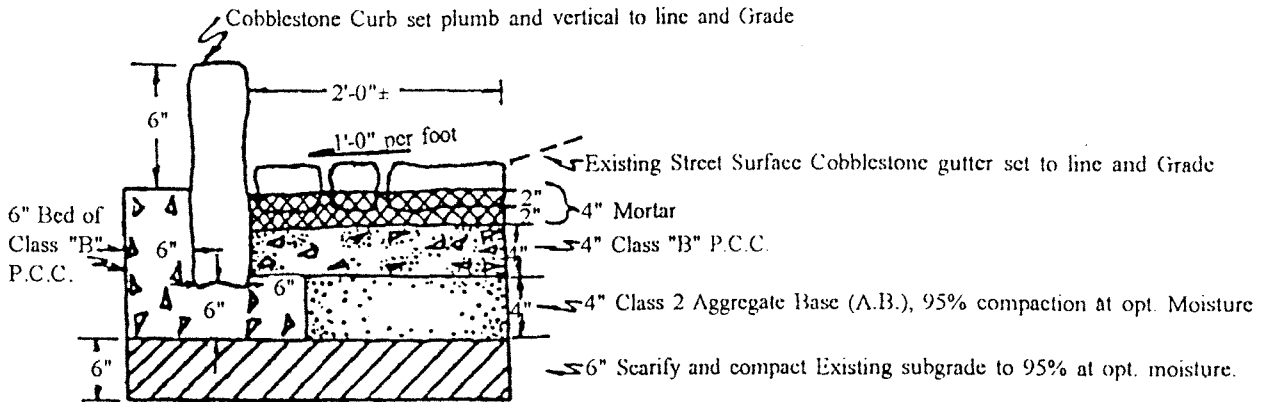
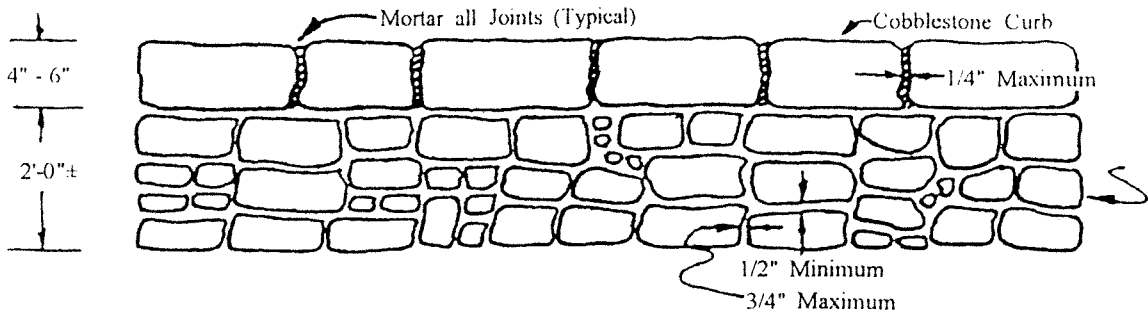

NOTE: Where existing gutter is Cobblestone overlaid with asphalt concrete (AC) - Remove, salvage and deliver stone to *City Street Corporation Yard*. Replace gutter with Standard City P.C.C. Gutter and overlay "In Kind". (See Below)

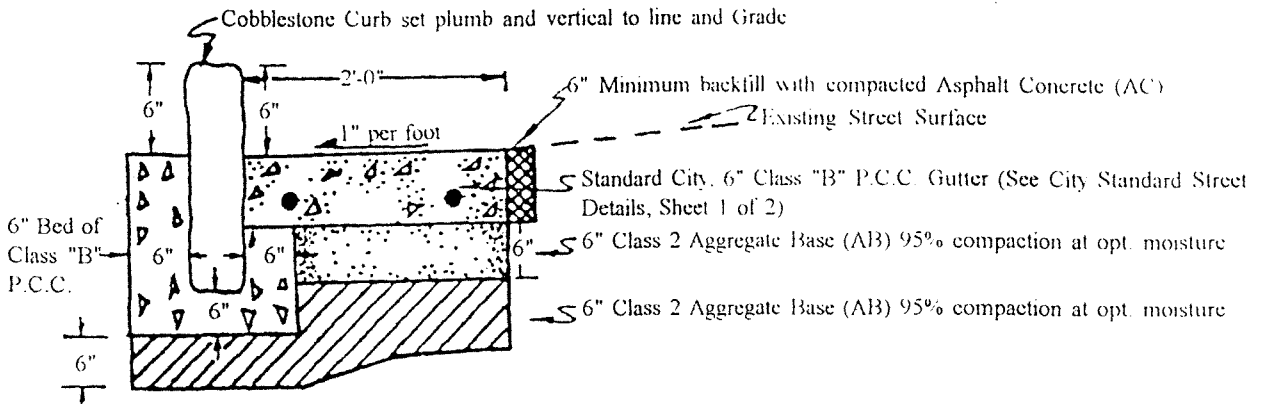
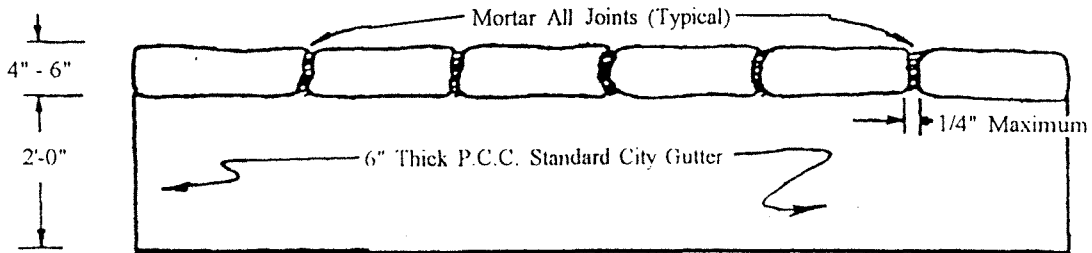

NOTE: Match "NEW" P.C.C. Gutter to existing P.C.C. Gutter. Replace any Asphalt Concrete (AC) overlay in the gutter "In Kind". *DO NOT* offset flowline of P.C.C. Gutter to conform to any Asphalt Concrete (AC) Overlay

CITY OF PETALUMA
Department of Engineering

22 Bassett Street - Petaluma California 94952
707 778 4304 - Fax 707 778 4437

Approved By

Ed Hays
Ed Hays R.C.E. 22366

Major Reconstruction
**RETENTION OF
COBBLESTONE**

Curb and/or Gutter

Drawn by
Butch Smith

Scale

N T S

Date

September 9th 1996

File Number

Std. No. SS00000 216 1 of 3



Page

215

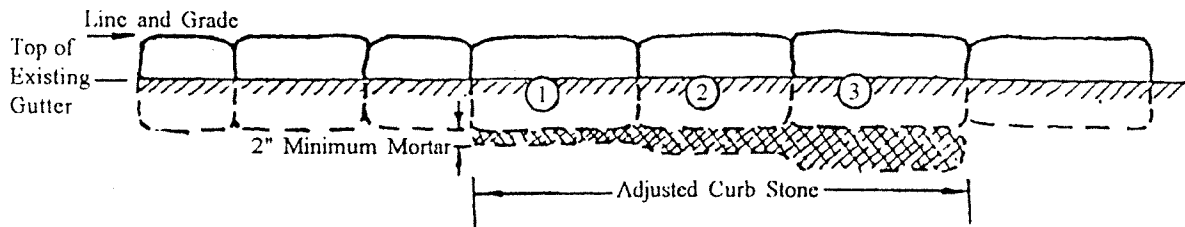
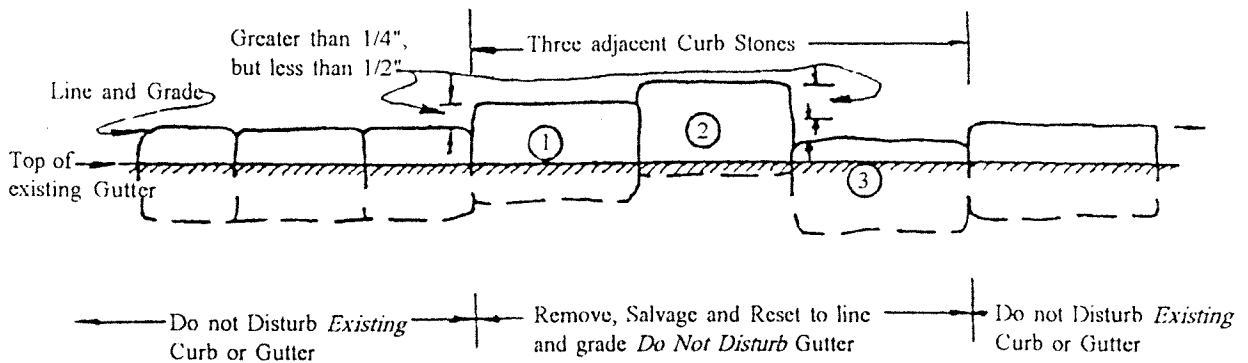

ELEVATION

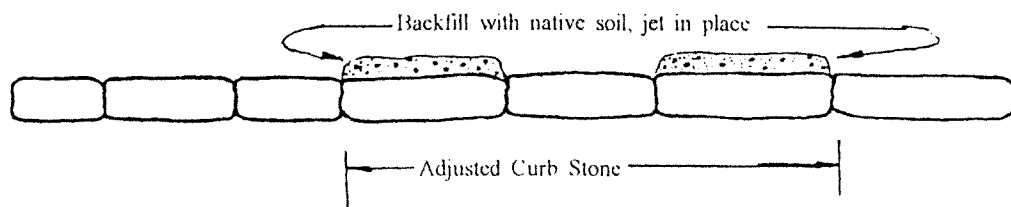
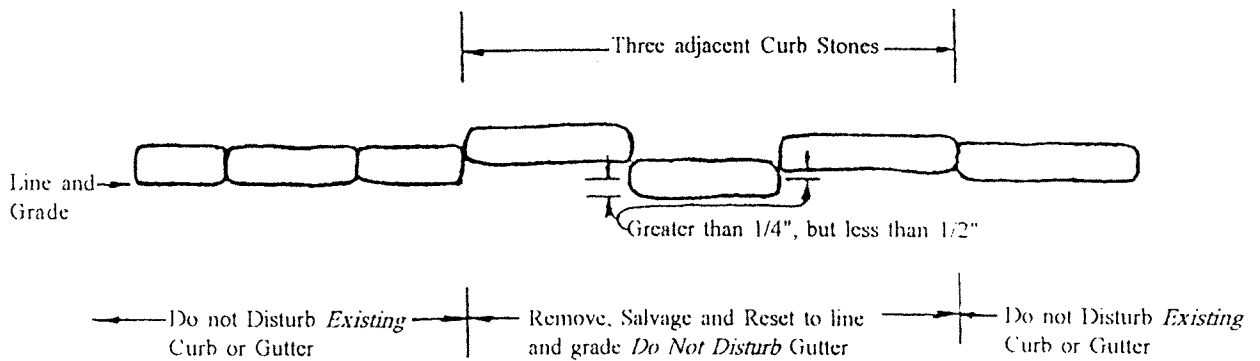

PLAN VIEW

CITY OF PETALUMA
 Department of Engineering
 22 Bassett Street - Petaluma California 94952
 707 778 4301 Fax 707 778 4137
 Approved By
Ed Hargis
 Thomas S. Hargis, P.E. 223466

Minor Reconstruction
**RETENTION OF
 COBBLESTONE**
 Curb and/or Gutter

Drawn By
Butch Smith
 Scale
 N. T. S.
 Date
September 9th 1996
 File Number
 Std Det. SS00000210 2 of 3

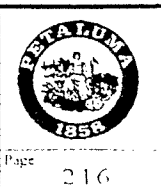

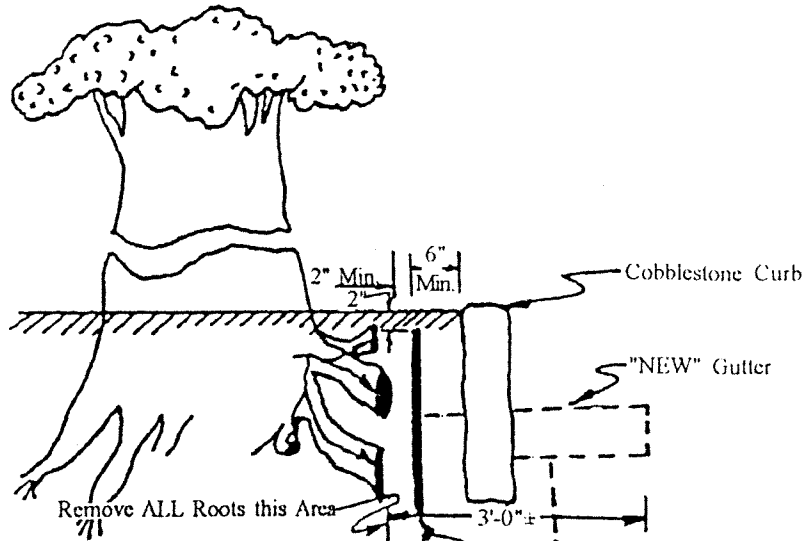

All Heart Redwood 1" x 10" creosoted Root Deflector extend 5 linear feet each way from centerline of the Tree.

ELEVATION

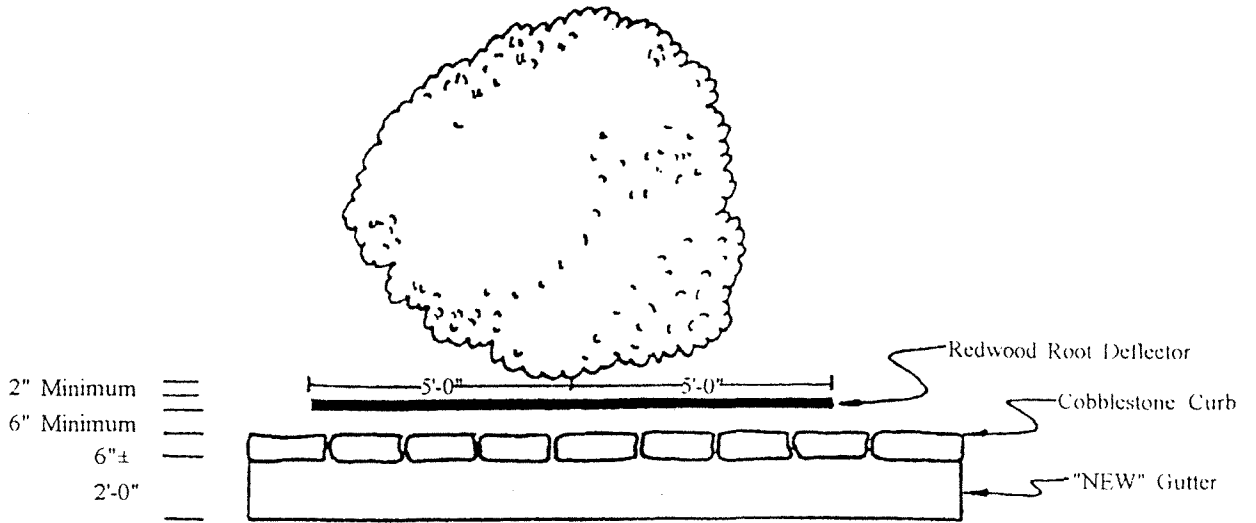

PLAN VIEW

<p>CITY OF PETALUMA Department of Engineering 22 Bassett Street - Petaluma California 94952 707 778 4304 - Fax 707 778 4437</p> <p>Approved By <i>Thomas N. Hartz</i> Thomas N. Hartz - R.C.E. 2237</p>	<p>Major TREATMENT For TREE ROOTS</p>	<p>Drawn By Butch Smith Scale N T S Date September 9th 1996 Site Number SSD0000 216 3 of 3</p>	 <p>216</p>
---	--	--	--

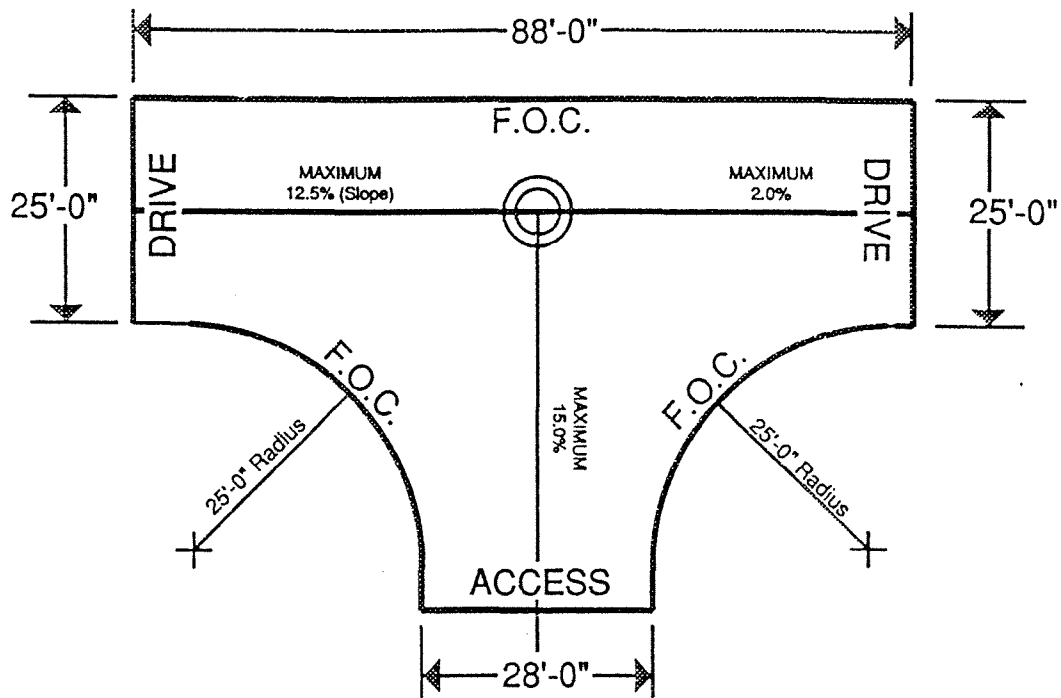

HAMMERHEAD TURN-AROUND

<p>CITY OF PETALUMA Department of Engineering 22 Bassett Street - Petaluma California 94952 707 778 4304 Fax 707 778 4437</p> <p>Approved By <i>Z. Hargis</i> Hammerhead Turn-Around (C.D.) 22360</p>	<p>Standard Detail HAMMERHEAD TURN AROUND</p>	<p>Drawn By Butch Smith Scale N.T.S. Date September 30th 1996 File Number Std Det - SSD, page 217 of 4</p>	 <p>Page 217</p>
--	--	---	--

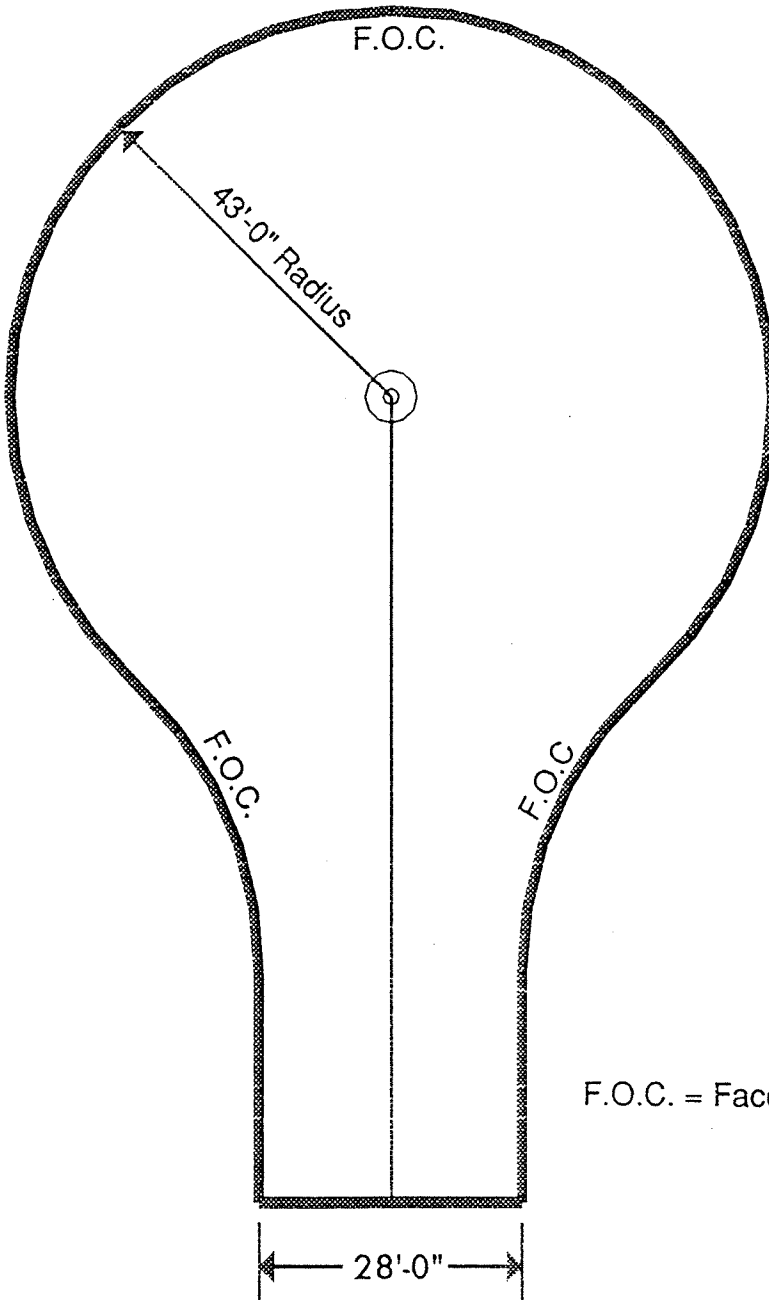

F.O.C. = Face of Curb

CUL-DE-SAC

<p>CITY OF PETALUMA Department of Engineering 22 Bassett Street - Petaluma California 94954 707 778-4304 - Fax 707 778-1137</p> <p>Approved By <i>Tom Harris</i> Thomas S. Harris, P.E., R.C.T., C.E.</p>	<p>Standard Detail CUL-DE-SAC</p>	<p>Drawn By Butch Smith Scale N T S Date October 1st 1996 File Number Std Det - SSD0000 217 2 of 3</p>	 <p>1858</p>
---	---	---	---

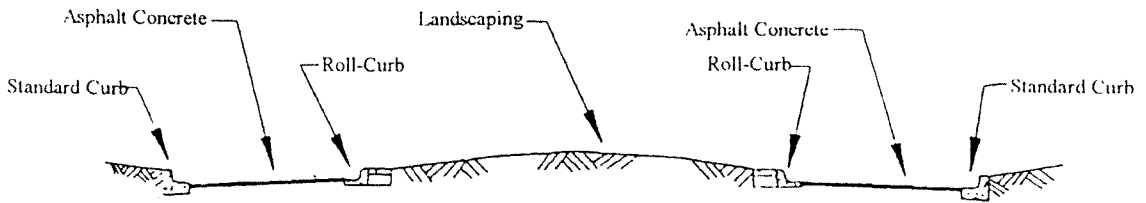

SECTION A-A

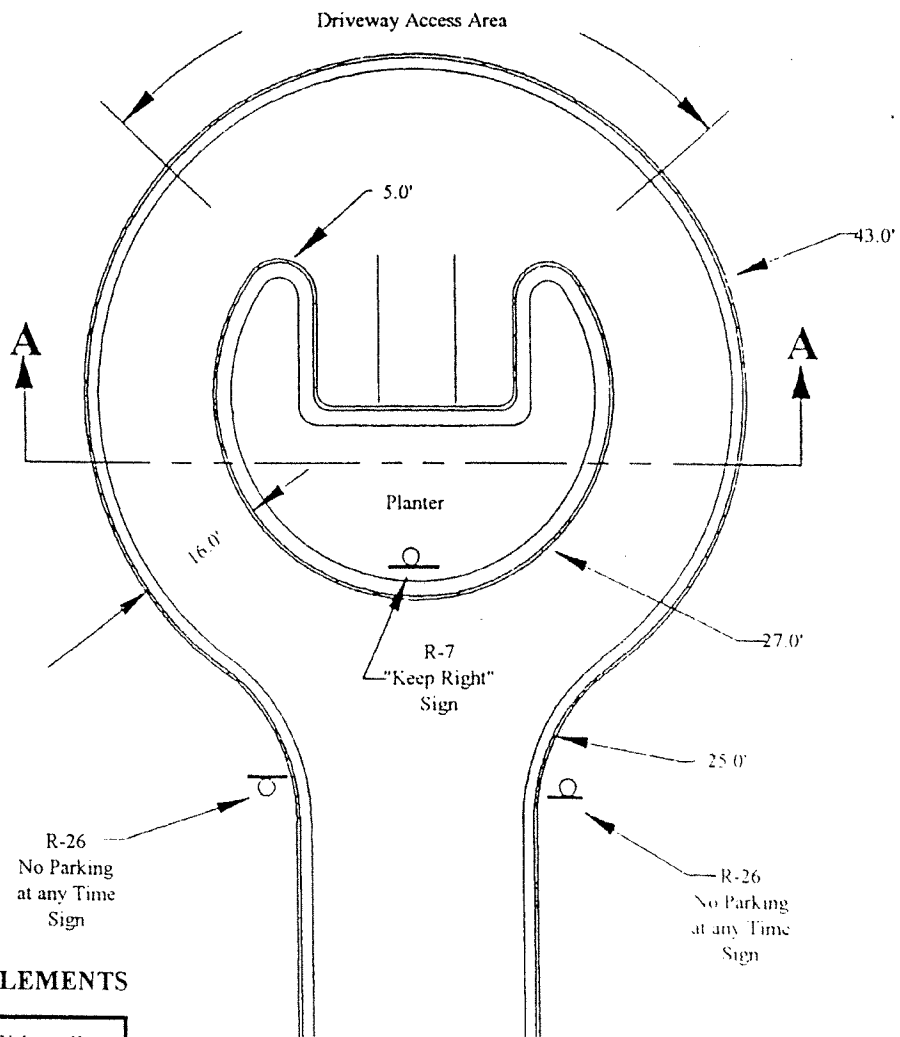

STREET DESIGN ELEMENTS

Driveway Access	Sidewalks
Permitted	Yes

CITY OF PETALUMA
Department of Engineering

22 Bassett Street Petaluma California 94952
707 778 1301 Fax 707 778 4437

Approved By

F. J. Hargis
City Engineer R.C.E. 22566

Standard Street Configuration
MINOR
RESIDENTIAL
CUL-DE-SAC STREET

Drawn By
Butch Smith

Scale
N T S

Date
November 13th 1996

File Number
Std Det **SSD 100-217 3 of 4**



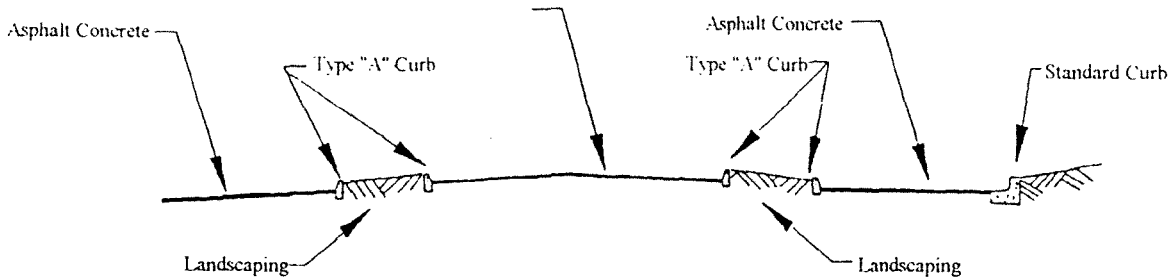

SECTION A-A

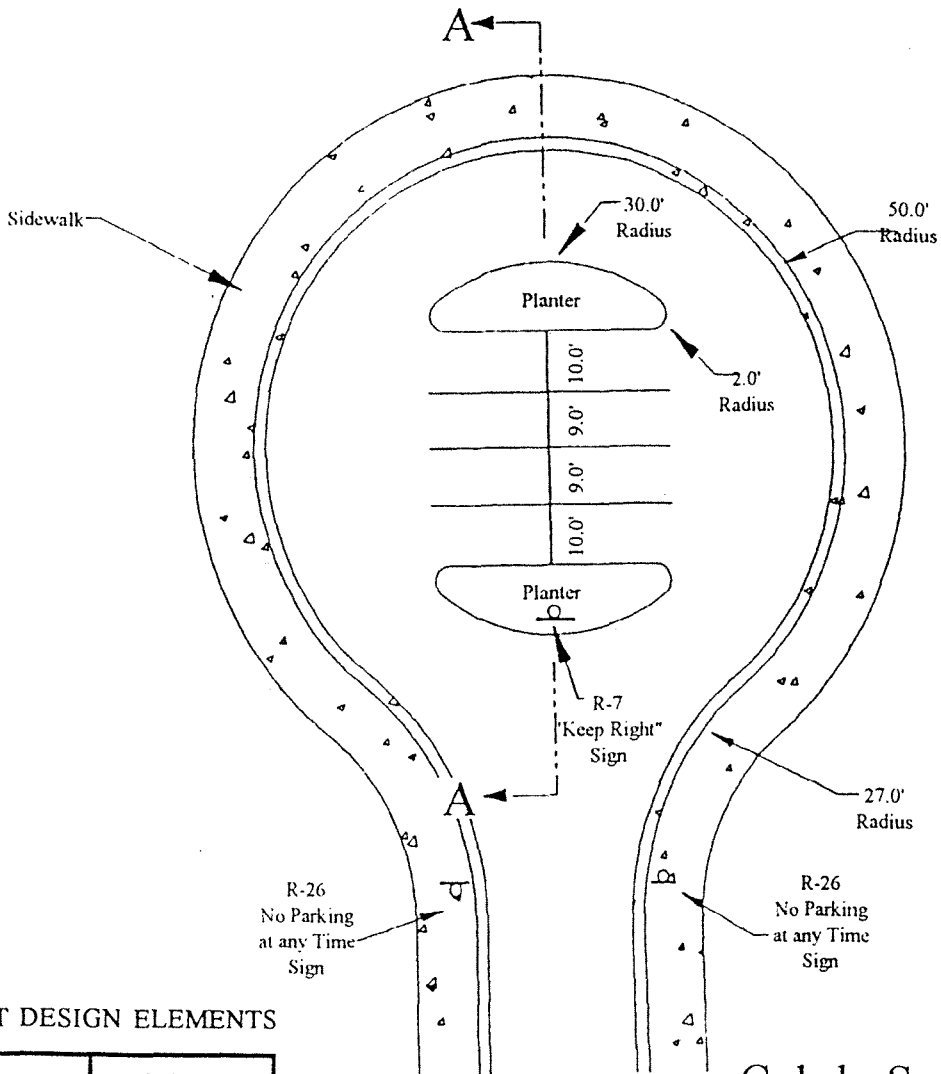

STREET DESIGN ELEMENTS

Driveway Access	Sidewalks
Permitted	Yes

Cul-de-Sac Serving 6 Dwelling units or more.

CITY OF PETALUMA
 Department of Engineering
 22 Bassett Street - Petaluma California 94952
 707 778 4304 - Fax 707 778 4437

Approved By
Thomas S. Hargis
 Thomas S. Hargis - R.C.E. 22366

Standard Street Configuration
**RESIDENTIAL
 CUL-DE-SAC
 STREET**

Drawn By
Butch Smith

Scale
 N. T. S.

Date
 May 11th 1999 (Rev.)

File Number
 Std. Det. SSD0000.217 4 of 4



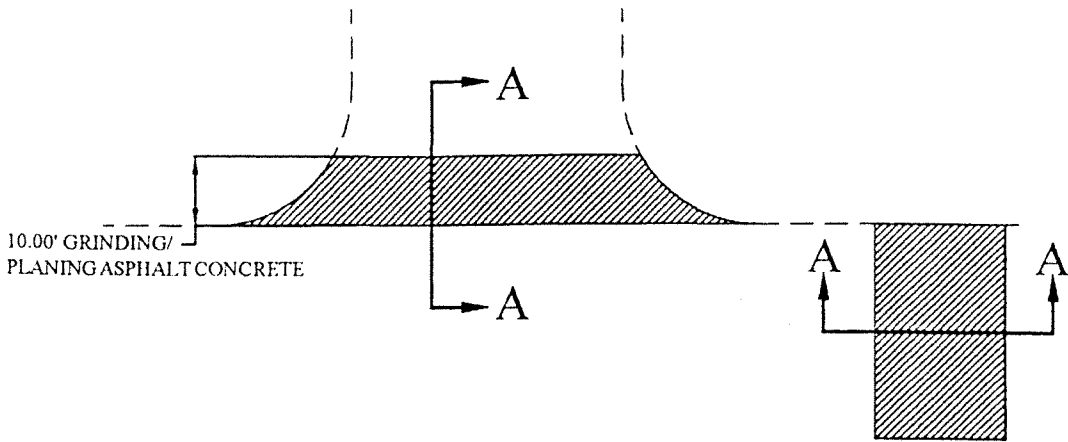

SIDE STREET AND END OF OVERLAY CONFORM (TYPICAL)

SCALE: N.T.S.

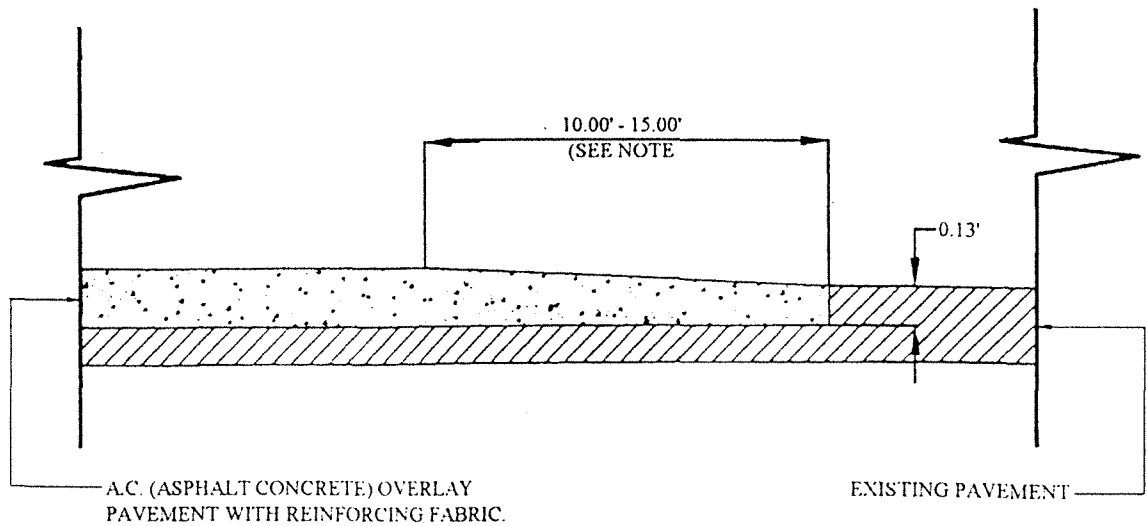

SECTION A-A

NOTE: COLD PLANING 10.00' SIDE STREET COLD PLANING
15.00' AT BEGINNING AND END OF OVERLAY
SCALE: N.T.S.

NOTE:

1. GRINDING / PLANING SHALL BE 0.13'
2. DESIGN SHALL CONFORM TO THESE REQUIREMENTS EXCEPT AS OTHERWISE APPROVED BY THE CITY ENGINEER.

<p>CITY OF PETALUMA Department of Engineering 22 Bassett Street - Petaluma California 94952 707 778 4304 - Fax 707 778 4437</p> <p>Approved By <i>Thomas S Hargis</i> Thomas S Hargis - R.C.E. 22366</p>	<p>Street Standard</p> <h2 style="margin: 0;">SIDE STREET AND END OF OVERLAY CONFORM</h2>	<p>Drawn by Butch Smith Scale N. T. S. Date December 30th 1998 File Number Std.Det. SSD0000.218 1 of 3</p>	 Page 218 01
---	---	---	---

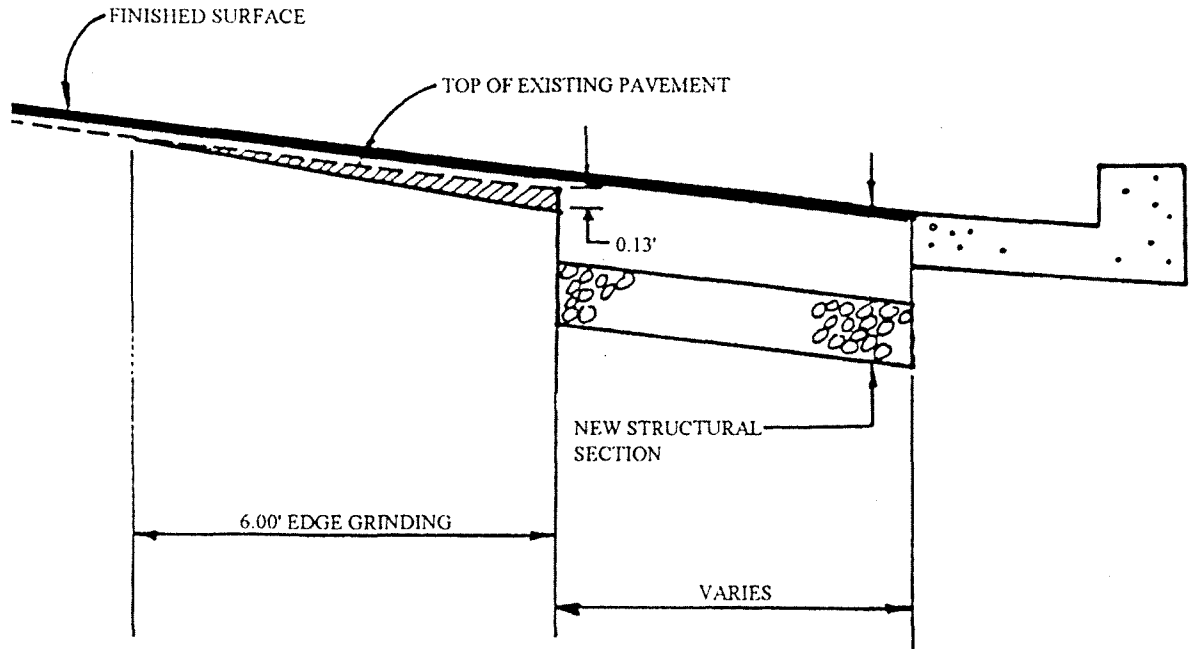

NOTE:

DESIGN SHALL CONFORM TO THESE REQUIREMENTS EXCEPT AS OTHERWISE APPROVED BY THE CITY ENGINEER.

FINISHED A.C. GRADE SHALL BE 0.02' ABOVE THE LIP OF GUTTER.

CITY OF PETALUMA
 Department of Engineering
 22 Bassett Street - Petaluma California 94952
 707 778 4304 - Fax 707 778 4437

Approved By
Thomas S Hargis
 Thomas S Hargis - R.C.E. 22366

Street Standard
**EDGE GRINDING
 AT NEW
 STRUCTURAL SECTION**

Drawn By
Butch Smith
 Scale
 N. T. S.
 Date
 December 30th 1998
 File Number
 Std.Det. SSD0000.218 2 of 3

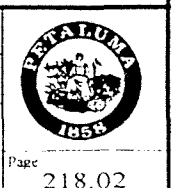

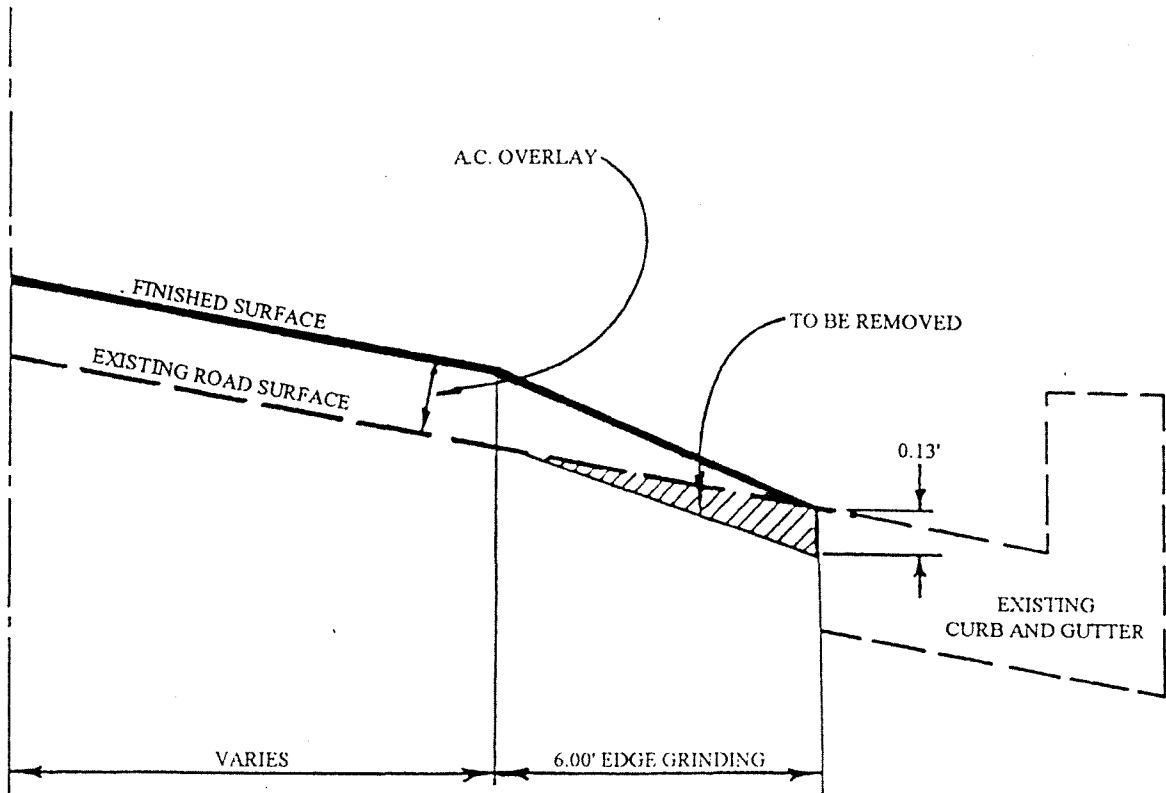

NOTE:

DESIGN SHALL CONFORM TO THESE REQUIREMENTS EXCEPT AS OTHERWISE APPROVED BY THE CITY ENGINEER.

FINISHED A.C. GRADE SHALL BE 0.02' ABOVE THE LIP OF GUTTER

CITY OF PETALUMA
 Department of Engineering
 22 Bassett Street - Petaluma California 94952
 707 778 4304 - Fax 707 778 4437

Approved By
Thomas S Hargis
 Thomas S Hargis - R.C.E. 22366

Street Standard
**EDGE GRINDING
 AT LIP OF GUTTER WITH
 OVERLAY SECTION**

Drawn By
 Butch Smith
 Scale
 N T S
 Date
 December 30th 1998
 File Number
 Std Det SSD0000.218 3 of 3



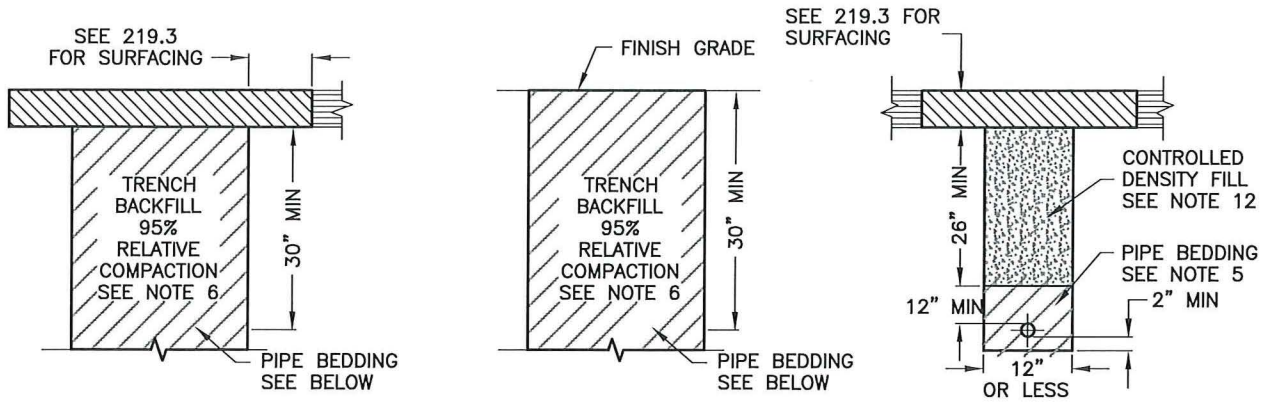

TYPE A
PAVED AREA

TYPE B
SHOULDER AREA

TYPE C
NARROW TRENCH

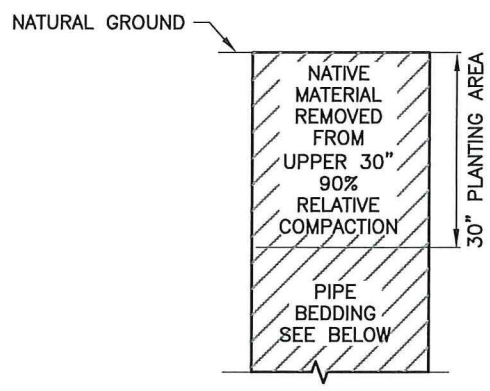

TYPE D
PUBLIC UTILITY EASEMENT
NON TRAFFIC LOADING AREA

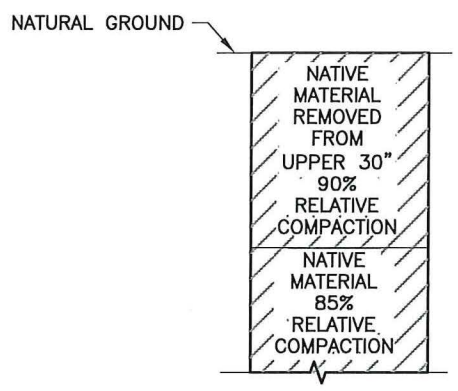

TYPE E
PUBLIC UTILITY EASEMENT
UNDEVELOPED AREAS
(APPROVAL REQUIRED)

TRENCH BACKFILL

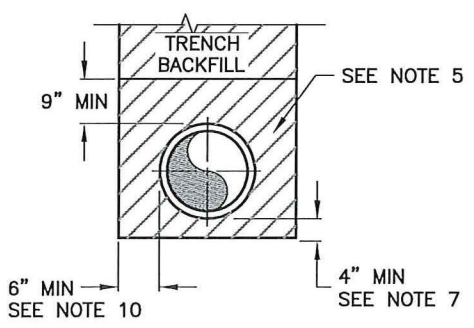

STABLE TRENCH

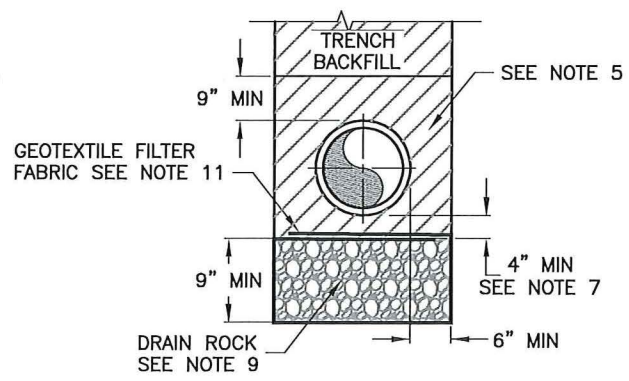

UNSTABLE TRENCH

PIPE BEDDING

NOTES:
1. SEE 219.2 FOR NOTES



CITY OF PETALUMA
PUBLIC WORKS & UTILITIES
UTILITIES DIVISION
202 N. McDOWELL BLVD. TEL. 707-778-4546
PETALUMA, CALIFORNIA 94954 FAX. 707-778-4508

**STANDARD TRENCH
DETAILS**

DATE: JAN 7, 2019 SCALE: N.T.S.
APPROVED BY:
Kent R. Carolthers
Kent R. Carolthers, P.E. Operations Manager C60671
DRAWN BY: TKM NO. 219.1

NOTES:

1. REFER TO ORDINANCE 2266 N.C.S. FOR PAVEMENT CUT IN STREETS WITH 5 YEARS FOR NEWLY CONSTRUCTED, RECONSTRUCTED, OR RESURFACED AND 2 YEARS FOR RESURFACING FOR SLURRY SEAL OR MICROSURFACE.
2. ASPHALTIC CONCRETE SHALL CONFORM TO THE REQUIREMENTS OF THE STATE OF CALIFORNIA DEPARTMENT OF TRANSPORTATION STANDARD SPECIFICATIONS, SECTION 39.
3. SAW CUT PAVEMENT NEAT LINE STRAIGHT, AS SHOWN ON STD DETAIL 219.1, FROM TRENCH WALL TO SUBGRADE. PAINT BINDER (TACK COAT) SHALL BE APPLIED TO ALL VERTICAL SURFACES. MATCH EXISTING A.C. THICKNESS OR USE A.C. THICKNESS TABLE WHICHEVER IS GREATER.

ADDITIONAL PAVEMENT REMOVAL:

REMOVE ADDITIONAL PAVEMENT TO A PAINTED VEHICLE LANE STRIPE, LIP OF GUTTER, CURB, A CENTERLINE OR EDGE OF PAVEMENT IF SUCH STREET FEATURE IS WITHIN 3' (FEET) OF THE FINAL SAW CUT, SUBJECT TO CITY APPROVAL. REMOVAL OF ADDITIONAL PAVEMENT TO ADJACENT EXISTING OR NEW PAVEMENT PATCH, IF PATCH IS WITHIN 5' OF FINAL SAWCUT.

4. DIFFERENT TRENCH SECTIONS MAY BE REQUIRED AND SPECIFIED BY PUBLIC WORKS & UTILITIES.
5. PIPE BEDDING MATERIAL SHALL BE CLASS 2 AGGREGATE BASE COMPACTED TO 90% RELATIVE COMPACTION AT OPTIMUM MOISTURE OR AS APPROVED BY PUBLIC WORKS & UTILITIES.
6. TRENCH BACKFILL SHALL BE CLASS 2 AGGREGATE BASE. THE UPPER 30" SHALL BE COMPACTED AT OPTIMUM MOISTURE AND SHALL CONFORM TO THE REQUIREMENTS OF THE STATE OF CALIFORNIA DEPARTMENT OF TRANSPORTATION STANDARD SPECIFICATIONS, SECTION 26 OR AS APPROVED BY PUBLIC WORKS & UTILITIES. (USE OF RECYCLED CL2 AB ONLY UPON APPROVAL BY THE CITY AND PROJECT GEOTECHNICAL ENGINEER.)
7. 1/4 PIPE OUTSIDE DIAMETER MINIMUM WHEN EXCAVATION IS IN ROCKY GROUND.
8. OPTIONAL BACKFILL- CONTROLLED DENSITY FILL (C.D.F.) MIX NO. 1500 (95% RELATIVE COMPACTION) SHALL CONFORM TO NOTE 12.
9. DRAIN ROCK MAY BE USED AS BEDDING UNDER PIPE FOR SLOPES LESS THAN 8%. DRAIN ROCK SHALL BE 100% CRUSHED AND SHALL CONFORM TO THE FOLLOWING GRADING:

1-1/2"	1"	1/2"	#4
100	95-100	0-30	0-4

DRAIN ROCK SHALL BE COMPACTED WITH A SURFACE VIBRATOR. PIPE BEDDING MATERIAL WHEN PLACED OVER DRAIN ROCK SHALL BE SEPARATED BY GEOTEXTILE FILTER FABRIC (MIRAFI 140NC) TO PREVENT MIGRATION AND COMPACTED WITH A SURFACE VIBRATOR CONFORMING TO NOTE 5.

10. IF PIPE DIAMETER IS LESS THAN 18" = 9" MAX.
IF PIPE DIAMETER IS GREATER THAN 18" = 12" MAX.
11. GEOTEXTILE FILTER FABRIC (MIRAFI 140NC OR EQUAL) SHALL BE APPLIED AS SHOWN IN THE UNSTABLE TRENCH DETAIL WRAPPED AROUND THE DRAIN ROCK WITH A 1' (ONE FOOT) MINIMUM OVERLAP.
12. CONTROL DENSITY FILL (CDF):
SHALL BE MIX DESIGN NO. 1500 MANUFACTURED BY SHAMROCK MATERIALS, INC. OR MIXTURE OF PORTLAND CEMENT, SAND AND 1" MAXIMUM COARSE AGGREGATE, AIR ENTRAINING AGENT AND WATER, BATCHED BY A READY-MIXED CONCRETE PLANT AND DELIVERED TO THE JOB SITE BY MEANS OF TRANSIT MIXING TRUCKS. CONTROL DENSITY FILL MAY ALSO CONTAIN CLASS F POZZOLAN (FLY ASH). CONTROL DENSITY FILL SHALL BE FREE OF ASPHALTIC MATERIAL.

MATERIALS:

CEMENT SHALL MEET THE STANDARDS AS SET FORTH IN ASTM C-150, TYPE II CEMENT.
FLY ASH SHALL MEET THE STANDARDS AS SET FORTH IN ASTM C-618, FOR CLASS F POZZOLANS. THE FLY ASH SHALL NOT INHIBIT THE ENTRAINMENT OF AIR.

AGGREGATE SIZE 1" MAX.
SAND - ASTM C33

MIX PROPORTIONS:

THE MIX PROPORTIONS SHALL BE DETERMINED BY THE PRODUCER OF THE CONTROL DENSITY FILL TO PRODUCE A FLOWABLE FILL MIXTURE WHICH WILL NOT SEGREGATE. EACH YARD SHALL CONTAIN NOT LESS THAN 50 POUNDS OF PORTLAND CEMENT AND NOT LESS THAN A TOTAL OF 100 POUNDS OF CEMENTIOUS MATERIAL. THE CONTRACTOR SHALL SUPPLY A MIX DESIGN TWO WEEKS PRIOR TO ANY USE OF CONTROL DENSITY FILL.

MIXTURE PROPERTIES:

COMPRESSIVE STRENGTH 75-200 PSI AT 28 DAYS
SLUMP = FLOWABLE (6"-9")

THE CONSISTENCY OF CDF SHALL BE SUCH THAT ALL TRENCH VOIDS ARE FILLED WITH MINIMUM RODDING OR VIBRATING BUT NOT SO WET AS TO CAUSE EXCESSIVE SHRINKAGE.

PAVING:

13. PERMANENT PAVEMENT MAY BE PLACED DIRECTLY UPON THE CONTROL DENSITY FILL AS SOON AS IT HAS CONSOLIDATED FOR THE SURFACE TO WITHSTAND THE PROCESS OF PAVING WITHOUT DISPLACEMENT. THE SURFACE OF THE CONTROL DENSITY FILL SHALL BE FIRM AND UNYIELDING. ANY VISIBLE MOVEMENT VERTICALLY OR HORIZONTALLY OF THE CONTROL DENSITY FILL UNDER THE ACTION OF CONSTRUCTION EQUIPMENT OR OTHER MAXIMUM LEGAL AXLE LOADS SHALL BE CONSIDERED AS EVIDENCE THAT THE CONTROL DENSITY FILL DOES NOT MEET THIS REQUIREMENT. THE CONTRACTOR SHALL PROVIDE TRENCH PLATES TO ALLOW TRAFFIC FLOW FOR ALL LOCATIONS UNTIL CONTROL DENSITY FILL IS READY TO BE PAVED.
14. FULL TACK COAT COVERAGE ON ALL VERTICAL SURFACES.
15. TRENCH SHALL BE PAVED WITH ASPHALT CONCRETE WHERE THICKNESS IS EQUAL TO THE THICKNESS OF THE EXISTING PAVEMENT BUT IN NO CASE SHALL THICKNESS BE LESS THAN SHOWN IN THE ASPHALT CONCRETE THICKNESS TABLE. ASPHALT SHALL BE 1/2" TYPE A CONFORMING TO SECTION 39 OF THE STANDARD SPECIFICATIONS.



CITY OF PETALUMA

PUBLIC WORKS & UTILITIES
UTILITIES DIVISION

202 N. McDOWELL BLVD. TEL. 707-778-4546
PETALUMA, CALIFORNIA 94954 FAX. 707-778-4508

STANDARD TRENCH
DETAILS
(NOTES)

DATE: JAN 3, 2019

SCALE: N.T.S.

APPROVED BY:

[Signature]

Kent R. Carothers, P.E. Operations Manager C60671

DRAWN BY: TKM

NO. 219.2

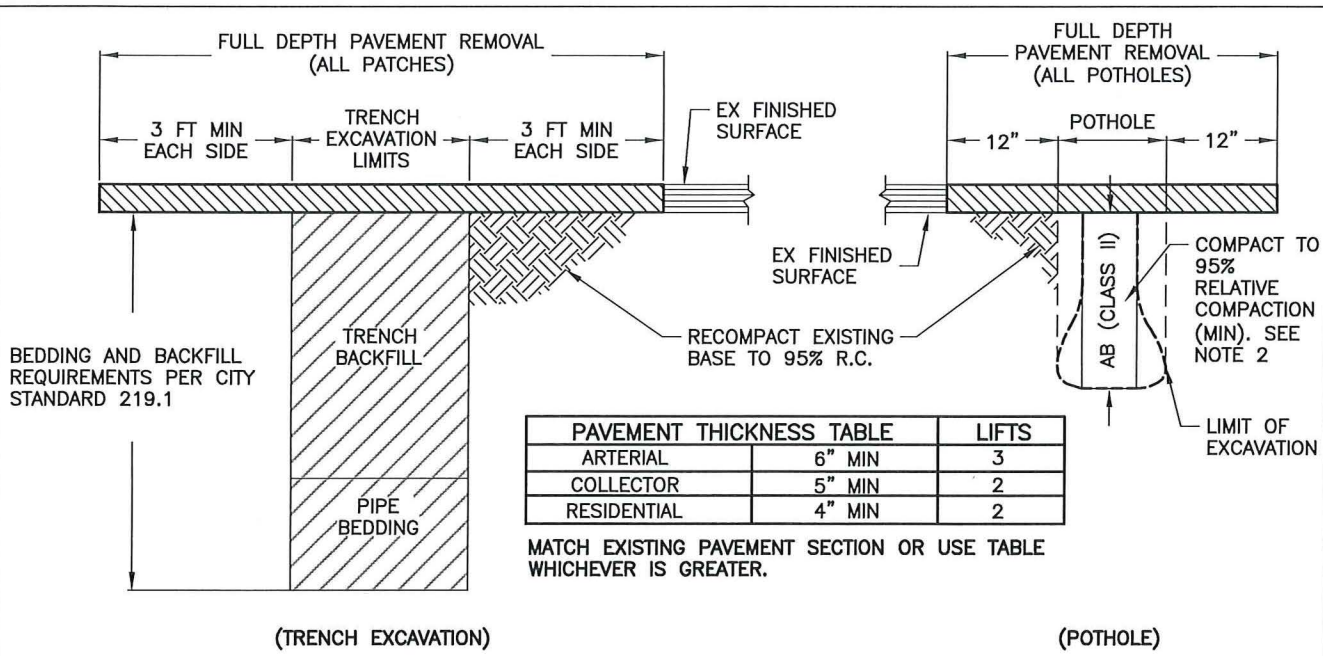

TYPICAL LIMITS OF REMOVAL

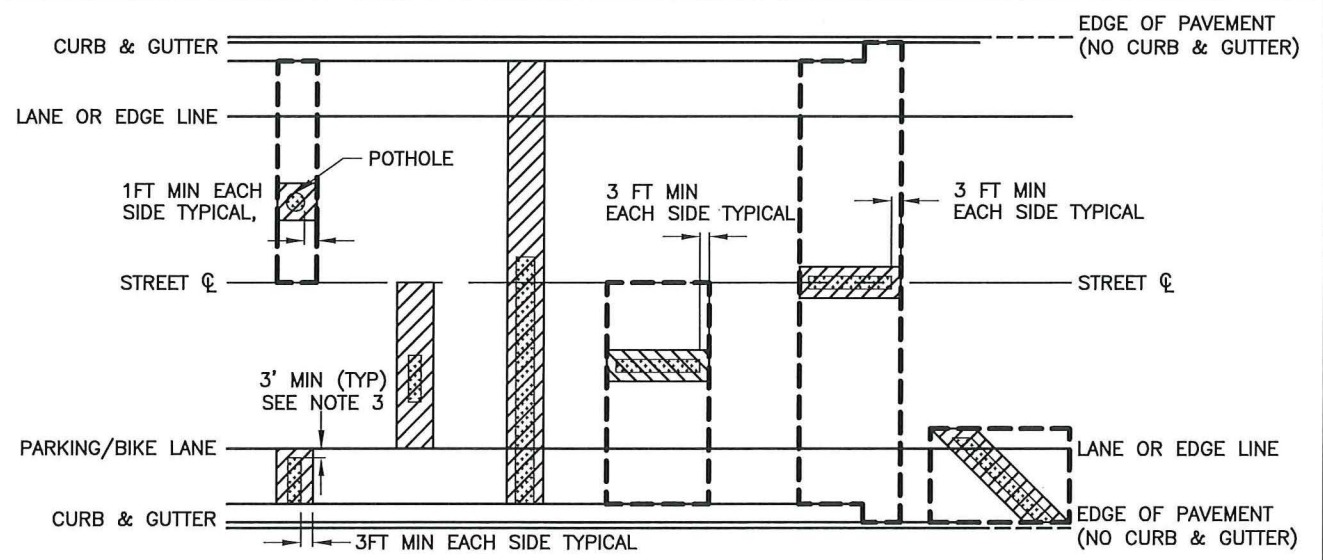

TYPICAL PAVEMENT CUTS

- REPLACEMENT LIMIT FOR ASPHALT 5 YEARS & NEWER, MICROSURFACE/SLURRY SEAL 2 YEARS & NEWER - 2" GRIND AND OVERLAY
- REPLACEMENT LIMIT FOR ASPHALT OLDER THAN 5 YEARS, MICROSURFACE/SLURRY SEAL OLDER THAN 2 YEARS - TYP. TRENCH SECTION (ABOVE)
- EXCAVATED AREA

NOTES:

1. PAVEMENT SURFACING SHALL CONFORM TO: CITY ORDINANCE NO. 2266 N.C.S. RESTRICTIONS ON EXCAVATION IN NEWLY CONSTRUCTED OR RESURFACED PUBLIC RIGHT-OF-WAY.
2. COMPACTION TESTS SHALL BE REQUIRED AS DEEMED NECESSARY BY THE CITY ENGINEER OR INSPECTOR.
3. SEE STANDARD 219.2 FOR ADDITIONAL NOTES.



CITY OF PETALUMA
PUBLIC WORKS & UTILITIES
 202 N. McDOWELL BLVD. TEL. 707-778-4546
 PETALUMA, CALIFORNIA 94954 FAX. 707-778-4508

PAVEMENT RESURFACING
LIMITS FOR PUBLIC
RIGHT-OF-WAY

DATE: JAN 9, 2019 SCALE: N.T.S.
 APPROVED BY:
 Kent R. Carothers, P.E. Operations Manager C60671
 DRAWN BY: TKM NO. 219.3

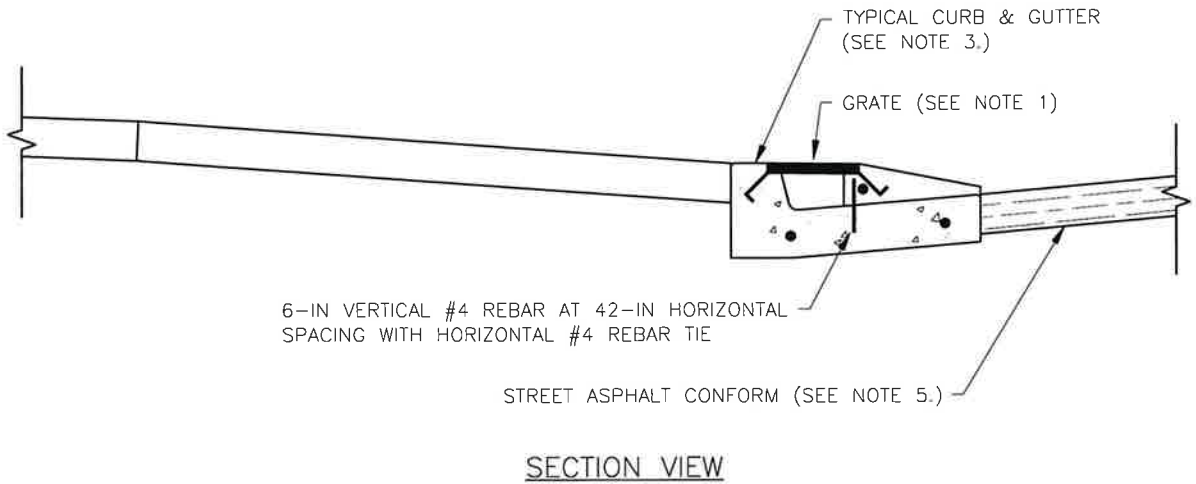
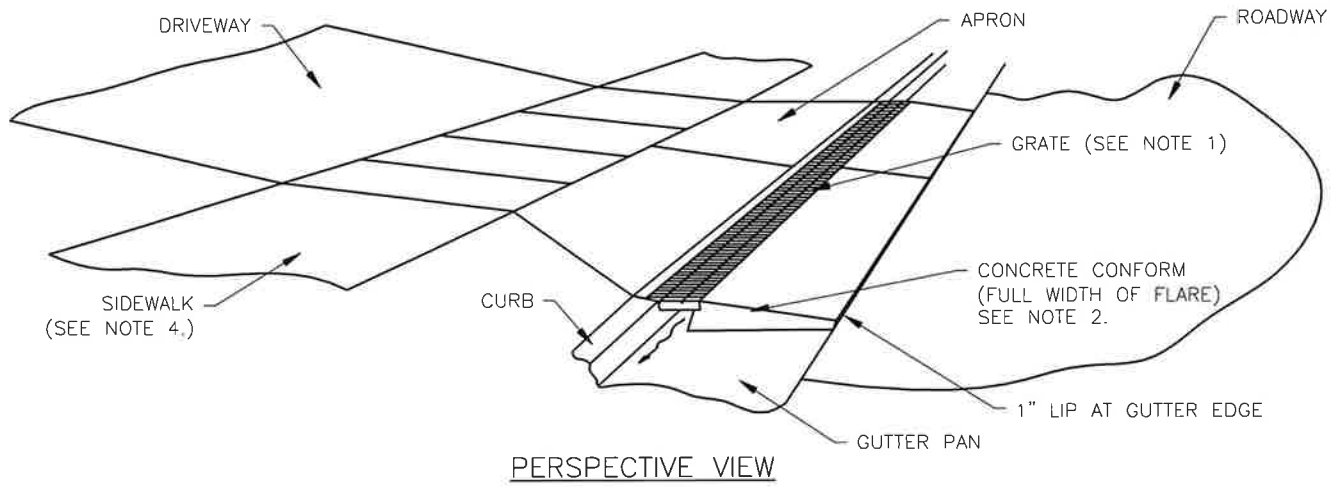

NOTES:

1. 1-1/4" x 24" MINIMUM METAL BAR GRATE AND FRAME, LENGTH AS REQUIRED.
2. CHAMFER BOTH ENDS OF CONCRETE CONFORM WITH 2:1 SLOPE.
3. NEW CURB & GUTTER CONSTRUCTION PER CITY STANDARD SHALL MAINTAIN HORIZONTAL AND VERTICAL ALIGNMENT OF EXISTING CURB & GUTTER.
4. NEW SIDEWALK CONSTRUCTION SHALL BE PER CITY STANDARD WITH 1.5% MAX CROSS SLOPE.
5. STREET ASPHALT CONFORM SHALL BE 2'-0" OR GREATER AS DETERMINED BY CITY EVALUATION.



CITY OF PETALUMA

PUBLIC WORKS & UTILITIES
UTILITIES DIVISION

202 N. McDOWELL BLVD. TEL. 707-778-4546
PETALUMA, CALIFORNIA 94954 FAX. 707-778-4508

STANDARD DETAILS
DRIVEWAY APRON WITH
GUTTER GRATE
HIGH CROWN STREET

DATE: JUNE 2024

SCALE: N.T.S.

APPROVED BY:

Kent R. Carothers, P.E. City Engineer C60671

DRAWN BY: ETL

NO. 225.0

(Revised 7/27/98)

City of Petaluma
Petaluma, California

STREET CONSTRUCTION
DETAIL SPECIFICATION NO. 41

Description

- 4101.1 Description. The work to be done consists of furnishing machinery and materials, except as otherwise specified, which are required to construct and complete the work in a good and workmanlike manner, including the removal of any abandoned underground facilities, maintenance of any existing underground utilities, the disposal of excess excavation and final clean-up, to the satisfaction of the Engineer. Reference to the Standard Specifications shall mean the California Department of Transportation, (CALTRANS), July 1992, (or current revision) Standard Specifications.

Construction Methods

- 4102.1 Clearing and Grubbing and Concrete Removal. Clearing and grubbing shall consist of removing brush, trees and stumps, fences and all other obstructions to be removed for which a pay item has not been included in the proposal, within the construction limits indicated on the plans, and shall conform to the Division of Highways Standard Specifications, Section 15 and 16, as herein modified.

Attention is directed to Sections 7-1.11, 7-1.12 and 7-1.13, "Preservation of Property," "Responsibility for Damages," and "Disposal of Materials," of the Standard Specifications. Existing improvements, facilities, adjacent property, and trees and shrubbery that are not to be removed shall be protected from injury by the Contractor's operations. The Contractor shall give ample notification to and cooperate during clearing and grubbing operations with public utility companies or others having overhead and/or underground facilities within the limits of work. Existing traffic, directional, and street signs shall be maintained until final relocation after sidewalks are constructed.

Fencing, mail boxes, and signs not removed by property owners prior to this work shall be carefully removed and left for the re-use of the owner. All other materials cleared and/or grubbed shall become the property of the Contractor and shall be disposed of outside the limits of the work at a location to be provided by the Contractor and satisfactory to the Engineer.

Mail boxes that are designated for relocation on the plans shall be moved to the new locations as shown on the plans or as designated by the Engineer. Access, satisfactory to the Post Office Department, shall be maintained at all times to the new locations and to those mail boxes that are not moved.

Property fences which are designated for replacement or relocation shall be constructed at the new locations as designated on the plans or as directed by the

Engineer. Replacement fences shall be of the same quality and design as the original fence fronting the property.

The contract lump sum price for clearing and grubbing and concrete removal shall be full compensation for all costs necessary and incidental to clearing, grubbing and concrete removal, all as specified herein and as shown on the plans. Watering required for processing the work or mixing materials shall be furnished by the Contractor. The cost of water and watering shall be considered included in the various other items of work and no additional allowance will be made therefor.

If required by the Engineer, a dust palliative conforming to Section 18 of the Standard Specifications shall be used for the prevention of dust nuisance. Payment for the binder for dust palliative and all of the work involved in the application shall be considered included in the various other items of work and no additional allowance will be made therefor.

4102.2 Earthwork and Subgrade Preparation for Roadbed. Earthwork and subgrade preparation for roadbed shall consist of performing all operations necessary to prepare a suitable subgrade for roadbed conforming to the applicable provisions of Section 19 of the Standard Specifications, except as modified herein; to excavate all materials from the street right-of-way, roadway prism, or adjacent thereto when shown on the plans or ordered by the Engineer; to excavate all material of whatever nature necessary for construction of foundations for structures and drainage facilities; to excavate trenches for sewers, drainage pipes, water facilities, and electrical facilities; to place backfill around structures and drainage facilities and over underground pipes; to backfill ditches and depressions resulting from the removal of obstructions; to backfill holes, pits and other depressions within the roadway area; to remove unsuitable roadway material and replace with suitable material; to excavate and grade driveway approaches and connections; all as shown on the plans and typical cross sections or directed by the Engineer and as specified; and to furnish all labor, materials, tools and equipment, and do all the work of whatsoever nature which may be required to grade the roadway, curbs, gutters, sidewalks, prepare the roadbed subgrade and maintain them in the form specified until the acceptance of the contract.

All work shall conform to the applicable provisions of Section 19 of the Standard Specifications except as modified herein:

Relative Compaction. Shall conform with Section 19 of the State Standard Specification except as modified herein.

Relative compaction of subgrade in expansive soils shall be a minimum of 92 percent and be between 4 and 6 percentage points above optimum moisture content. Relative compaction of non-expansive soils shall be 95 percent at optimum moisture content.

Expansive soils are herein defined as soils with a "free-swell" of 50 or greater - non-expansive soils 50 or less.

Street Proof Rolling. After the street subgrade has been brought to the proper moisture content, compacted and fine graded, the Contractor shall furnish

subgrade "Proof Rolling" equipment equivalent to an "H-20" wheel load, subject to the approval of the Engineer, and thoroughly "proof-roll" the street subgrade in the presence of and to the satisfaction of the Engineer. Soft or yielding local subgrade spots shall be marked by the Engineer for repair by the Contractor. Subgrade in non-expansive soils shall be "unyielding." Subgrade in expansive soils may have a "temporary blanket yielding" not to exceed one-half (1/2) inch. Subgrade cracking or permanent indentation of wheel tracks shall be unacceptable.

Order of Subgrade Work. Unless otherwise specified in the special provisions, or on the plans, the street subgrade shall be completed and approved within the City right-of-way property line to property line, prior to placement of any aggregate on the subgrade.

Maintenance of Street Subgrade. The specified geometric shape, relative compaction and moisture content of the street subgrade shall be continuously maintained by the contractor and is subject to testing by the Engineer at any time prior to final acceptance of work by the City.

All rocks or solid lumps of material over four (4) inches in greatest dimension shall be broken up and removed from the upper six (6) inches of the graded roadbed and the resulting spaces refilled with approved material.

The cost of excavation, backfill, and subgrade preparation for structures and underground facilities shall be considered included in the contract price paid for the appropriate items of work.

The contract lump sum price for earthwork and subgrade preparation for roadbed shall be full compensation for all costs necessary and incidental to excavating and compacting the roadway prism and preparing the roadbed subgrade all as specified herein and as shown on the plans.

Watering and dust palliative, as specified in Section 4102.1 of these specifications, shall be considered included in the various other items of work and no additional allowance will be made therefore. (For the purpose of these "Detail Specifications," the term "roadbed" is used as defined in Section 1-1.34 of the Standard Specifications.)

4102.3

Aggregate Subbase. Aggregate subbase shall be Class 2 aggregate subbase conforming to the applicable provision of Section 25 of the Standard Specifications, and these special provisions. Test samples of the proposed material shall be taken by the Engineer. Sufficient time shall be provided to permit evaluation of the samples. No material may be placed without approval by the Engineer.

Measurement and Payment. Quantities of aggregate subbase shall be measured and paid for by the square foot unless specified otherwise in the Special Provisions or Bid Schedule.

The contract unit price for aggregate subbase, in place, shall include full compensation for furnishing all materials, labor, equipment, and performing all work necessary, including water and watering, to complete the road subbase as

specified and where shown on the plans, and no additional allowance will be made.

- 4102.4 Aggregate Base. Aggregate base shall be Class 2, three-quarter (3/4) inch maximum, aggregate base conforming to the applicable provisions of Section 26 of the Standard Specifications, and these Detail Specifications.

Measurement and Payment. Quantities of aggregate base shall be measured and paid for by the square foot unless specified otherwise in the Special Provisions or Bid Schedule.

The contract unit price for aggregate base, in place, shall include full compensation for furnishing all materials, labor, equipment, and performing all work necessary including water and watering, to complete the aggregate base as specified and where shown on the plans, and no additional allowance will be made.

- 4102.5 Plant Mixed Cement Treated Base. Plant mixed cement treated base shall be Class A cement treated base conforming to the applicable provisions of Section 27 of the Standard Specifications.

Test samples of the proposed material shall be taken by the Engineer. Sufficient time shall be provided to permit evaluation of the samples. No material may be placed without approval by the Engineer.

Measurement and Payment. Quantities of plant mixed cement treated base will be measured and paid for at the contract price per square foot.

- 4102.6 Asphalt Concrete. Asphalt concrete shall be Type A, 1/2-inch maximum, medium and shall conform to the provisions in Section 39, "Asphalt Concrete", of the Standard Specifications and these special provisions.

Asphalt concrete shall be placed only when the atmospheric temperature is above 50⁰F.

The Contractor shall submit the asphalt concrete mix design for the Engineer's approval not less than ten (10) working days prior to commencing paving operations. Asphalt windrow pickup machine is not allowed to be used for paving. The amount of asphalt binder to be mixed with the aggregate shall be approximately 5.6 percent by weight of the dry aggregate. Exact rate shall be determined by the Engineer and shall not vary by more than 0.3 percent above or 0.3 percent below the amount designated by the Engineer. Asphalt concrete shall be obtained from a source located no more than 30 miles from the job site.

All costs involved in placing asphalt concrete used for trench resurfacing shall be included in the prices paid for the various contract items of work and no additional payments will be allowed therefore.

Tack coat of 70 percent SS-1 and 30 percent water shall be furnished and applied uniformly to a pavement to be surfaced and to contact surfaces of all cold pavement joints, curbs, gutters and to other surfaces designated by the Engineer. Tack coat shall be applied at the rate of 0.10 gallons per square yard. A prime coat of liquid asphalt SC-70 shall be applied at the rate of 0.25 gallons per square yard when required by the plans or specifications.

Tack coat and prime coat will not be measured for payment and full compensation therefore will be considered as included in the prices paid for the various contact items of work and no additional payments will be allowed.

Relative compaction will be determined by California Test 375. Laboratory specimens will be compacted in conformance with California Test 304. If the test results for any lot of asphalt concrete indicate that the relative compaction is less than 93.0 percent, the asphalt concrete represented by that lot shall be removed and replaced at Contractor's expense. Asphalt concrete spreading operations shall not continue until the Contractor makes significant adjustments to his/her materials or procedures or both in order to meet the required compaction. The adjustments shall be as agreed to by the Engineer.

All existing water valves, sewer clean-outs, monuments, and manhole castings shall be adjusted to the finished grade by the Contractor within 48 hours after paving over each structure.

A Certificate of Compliance shall be furnished to the Engineer in accordance with the provisions in Section 6-1.07, "Certificate of Compliances", of the Standard Specifications. The Contractor shall be charged for the costs of all tests where the test results do not meet the specifications.

Measurement and Payment: Asphalt concrete shall be measured and paid for by the tonnage unless specified otherwise in the Special Provisions or Bid Schedule. The contract prices and payments for asphalt concrete shall include full compensation for furnishing all labor, materials, tools, equipment, incidentals, and for doing all the work involved in constructing asphalt concrete, complete in place, as shown on the plans and as specified in these specifications and these special provisions, and as directed by the Engineer.

4102.7 Fog Seal Coat. A fog seal coat as specified in Section 37 of the Standard Specifications shall be applied to the finished pavement surface.

The contract lump sum price for mixing type asphaltic emulsion shall be full compensation for all costs necessary and incidental to placing the fog seal coat, including material, labor and equipment, all as specified herein and as shown on the plans.

4102.8 PCC Concrete Curbs, Gutters, Sidewalks, Driveways, Islands, Valley Gutters, and Curb Ramps. Concrete curbs, gutters, sidewalks, driveways, islands, valley

gutters and curb ramps shall conform with Section 73 of the Caltrans Standard Specifications except as modified herein and shall be as shown on Standard Plans 202, 203, 204, and 205 of the City of Petaluma Street Standard Details 200 Series.

The Contractor shall adjust all existing and new water meter boxes and any other service castings falling within the limits of work (except existing structures belonging to PG&E and Pacific Bell) to exact grade at the same time the concrete improvements are being constructed and shall maintain these appurtenances to true and exact grade until concrete is thoroughly set. The Contractor shall mark on the face of the curb and location of each sewer lateral with an "S" and each water service with a "W". Letters shall be approximately two and one-half (2-1/2) inches high, neatly stamped while the concrete is still green, and to the Engineer's satisfaction.

PCC - Placement by Extrusion Machine.

Portland Cement Concrete curbs, gutters, sidewalks and driveway approaches may, at the option of the Contractor, be placed using an approved extrusion machine provided:

1. All work shall conform with Section 73 of the State Standard Specifications as modified herein.
2. The PCC curb, gutter, sidewalk and driveway approaches shall conform with "City of Petaluma, Department of Public Works, Standard Street Details," Sheet 1 of 1, Current Revision, plans except as herein modified.
3. The aggregate base or subbase under the curb, gutter, sidewalk and driveway approaches shall be extended to the back of the sidewalk with a minimum thickness of 12 inches, under the sidewalk or driveway approach, compacted to a minimum of 90% relative compaction.
4. Subgrade shall have 95% compaction.
5. No expansion joints will be required.
6. Deep (1-1/2" minimum) transverse score marks shall be made at ends and center of driveways and at a maximum of 10-foot intervals along the sidewalk.
7. Four #4 x 20" reinforcing bar dowels and 4 - #4 bars shall be installed at drop inlet or other "block-out" locations.
8. Four #4 x 20" reinforcing steel dowels shall be placed at the location each placement "cut-off" where placement of PCC curb, gutter and sidewalk is to continue at a later date.
9. Other than as required above, no reinforcing steel, wire mesh or dowels will be required.
10. Concrete shall be 5 1/2 sack 3/4 maximum aggregate graded as required in Paragraph 73-1.01 of the 1984 State Standard Specifications.

Measurement and Payment - Curb and Gutter. Payment for PCC curb and gutter including island curb and gutter measured along and at the face of curb shall be made at the contract unit price per linear foot, in place, and shall be full compensation for furnishing and placing concrete gutter and integral curb, including reinforcing steel (where required) weakened plane and construction joints, "S" and "W" letters and subgrade preparation. Unless stipulated elsewhere in the contract documents, payment for curb and gutter shall also include furnishing, placing and compacting six (6) inches of aggregate base material under the curb and gutter.

Sidewalk, Driveway, PCC Island and Valley Gutter. Payment for sidewalks, driveways, island PCC paving and valley gutters shall be made at the contract unit price per square foot measured six (6) inches behind face of curb for all but valley gutters which shall be measured from lip of gutter to lip of gutter. Payment shall be full compensation for furnishing and placing PCC sidewalk, driveways, islands and valley gutters complete, in place, and shall include subgrade preparation, reinforcing bars and wire mesh where required, weakened place and construction joints and scoring. Unless stipulated elsewhere in the contract documents, payment for PCC sidewalk, driveways, islands and valley gutters shall also include furnishing, placing and compacting Class 2 aggregate base material under the facility.

4102.9 Redwood Headerboards. Headers shall be installed in locations indicated on drawings, and where specified. All headers shall be held in place with two (2) inch by three (3) inch stakes of lengths necessary to extend a minimum of twelve (12) inches into solid ground. All stakes shall be of sound material, neatly pointed, driven vertically and securely nailed to the headers.

Headers shall have a continuous bearing on undisturbed earth or compacted base rock. The backfill on the unimproved side of the header shall be compacted to the density of the undisturbed adjoining earth.

All headers and stakes shall be of heart structural redwood or dense structural redwood.

Additional stakes and anchorage required to hold the headers in place to true line and grade during construction shall be provided and placed by the Contractor at no extra cost.

The contract unit price per lineal foot for redwood headers, in place, shall include full compensation for furnishing all materials, labor, equipment, and performing all work necessary to complete the headerboards as shown on the plans and as herein specified.

4102.10 Monuments. Standard City monuments shall conform with the "City of Petaluma, Department of Public Works, Standard Street Details" Drawing Sheet 1 of 1, current revision and shall be constructed where shown on the plans and located by the Engineer for the Contractor.

Concrete shall be Class "A" conforming to the provisions of Section 90 of the Standard Specifications. The monument shall be constructed after placing of the asphalt concrete street surface.

The solid brass monument marker, as shown on the plans, shall be set in the concrete before the concrete begins to set. The Engineer shall stamp the marker for the Contractor.

The contract unit price for each monument, in place, shall include full compensation for furnishing all materials, labor, equipment, and performing all work necessary to complete the monuments, but not including locating and stamping the marker, and no additional allowance will be made.

4102.11 Standard City Street Barricade. Standard City Street Barricade shall be constructed as shown on "City of Petaluma, Department of Public Works, Standard Street Details" Drawing Sheet 1 of 1 current revision.

The contract unit price per lineal foot measured horizontally from end of railing to end of railing shall be full compensation for furnishing and placing the barricade complete in place including the redwood rails, posts, post holes, concrete, reflectors, paint, bolts, nuts, and traffic signs.

4102.12 Signing. Under this item the Contractor shall provide all the necessary equipment, labor and materials required to salvage, relocate and install new street signs and directional signs, complete in accordance with the Plans and as specified herein.

1. Traffic Sign Material

The base metal of all signs shall be new sheet aluminum of alloys 6061-T6 or 5052-H38 conforming to the requirements of ASTM Designation B 209.

Unless otherwise specified by the Engineer, the thickness of all signs shall be .080 inches, except for mast-arm mounted signs which shall be 0.125 inches.

All regulatory and warning signs shall be constructed to the standard size and specifications of the State of California, Department of Transportation. Signs larger than the standard sign may be required or may be granted approval by the Engineer.

All mast-arm mounted street name signs, advance street name signs and street name signs shall be constructed to Caltrans dimensions and specifications or as specified by the Engineer.

The following signs shall be constructed using High Intensity encapsulated lens sheeting and lettering: Stop signs (R1), yield signs (R1-2), keep right signs (R7), no u-turn (R34), stop ahead signs (W17), chevron signs (W81), mast-arm mounted street name signs, advanced street name signs, street name signs and Type N markers. This sheeting

and lettering shall hold a minimum warranty of ten (10) years. All other traffic signs shall be high intensity sheeting and lettering.

2. Traffic Signs Installation

Signs shall be placed in a concrete foundation in a fashion as shown on the City Standard Plans. Foundation concrete shall be Class "A". The sign posts sleeves shall have a minimum of two (2) inch clear space between post and native earth to be filled with concrete. Selected signs shall be placed on the street light standards at the designed height.

Signs shall be installed as per these specifications and facing traffic in the lane adjacent to which the sign is installed. "No Parking" signs shall be installed at a 30° angle toward the traveled way. All other signs shall be installed at an angle toward the traveled way. All other signs shall be installed at an angle toward the traveled way per the sign manufacturer's reflective requirements.

Signs in the median area shall be placed midway between curbs. These signs shall be mounted no closer than six (6) inches to, and no farther than six (6) feet from, the edge of the traveled way which the sign faces.

The minimum mounting height for signs shall be seven (7) feet measured from the bottom of the sign to the near edge of the pavement, except as otherwise noted below, or as specifically approved by the Engineer.

The height to the bottom of a secondary sign mounted below a primary sign shall be a minimum of six (6) feet measured from the bottom of the sign to the near edge of the pavement.

In areas not subject to pedestrian traffic, the Chevron (W81) and one way signs (R10) shall be mounted at a height of three (3) feet, measured from the bottom of the sign to the near edge of the pavement.

4102.13 Quality Test. The Contractor will be charged for the cost of all Quality Control Tests - i.e., compaction, sand equivalent, R. value, gradation, etc. - where the test results do not meet the required specifications.

Testing of aggregate bases shall be performed for every 500 cubic yards or one day's production, whichever is smaller. Testing of asphalt concrete shall be performed for every 500 tons or one day's production, whichever is smaller. Testing of Portland Cement Concrete shall be performed for every 300 cubic yards or one day's production, whichever is smaller.

4102.14 Adjusting Utility Structures to Grade. Work includes adjusting to finish grade any and all new or existing manholes, sewer cleanouts, water valve boxes, survey monument boxes, etc., which are included in the contract.

The Contractor shall mark the location of all structures to be adjusted to grade and shall be responsible for the location after paving operations are completed.

After surfacing or resurfacing is completed, the Contractor shall construct or reconstruct the structures to grade as shown on the plans.

Payment for adjusting structures to grade shall be by the unit price bid per each and shall be full compensation for adjusting and furnishing new or salvaging existing manhole frames and covers, water valve boxes, sewer clean out frames and cover, and monument covers.

4102.15 Permanent Surfacing. Permanent surfacing shall not be constructed until the compaction requirements are satisfied. The wearing surface for permanent surfacing shall be replaced "in kind", but in no case shall the new surfacing be less than two (2") inches thick for asphalt concrete or less than six (6") inches thick for Portland cement concrete. A permanent surface shall be installed no later than ten (10) calendar days from completion of backfill.

4102.16 Slurry Seal. Slurry seal shall be Type II and shall conform to the provisions in Section 37-2, "Slurry Seal", of the Standard Specifications and these special provisions.

At least five (5) days prior to the slurry seal operation, the Contractor shall hand out written notices to all local residents and/or businesses advising them of the operation and road and/or lane closures. The notices shall include the type of work, limits, date and the time period of road closure and/or no parking. Details of the notice shall be reviewed and approved by Director of Engineering at least five (5) working days prior to posting and/or delivery. "No parking" signs shall be placed behind the curbs at least 48 hours in advance of work and shall include date and time.

The Contractor's failure to comply with the requirements of this section will be sufficient cause for the Engineer to suspend work at no costs to the City.

In addition to providing the mix design, the Contractor shall provide the Engineer with a Certificate of Compliance certifying that the materials meet the specifications.

The contractor shall replace existing striping, pavement markings and pavement markers within the slurry seal areas. Pavement markings shall be thermoplastic applied at a minimum thickness of 0.125-inch. Pavement markers conforming to Section 85, "Pavement Markers", of the Standard Specifications shall be used for traffic stripes. Permanent striping, pavement markings and pavement markers shall not be placed until the new surface has been opened to traffic for a period of not less than seven (7) days.

Temporary pavement delineation, crosswalks and limit lines consisting of traffic paint conforming to Section 84-3, "Painted Traffic Stripes and Pavement Markings", of the Caltrans Standard Specifications, shall be in place at the end of the first day of slurry seal and shall be maintained until replaced by the permanent delineation and pavement markings.

Slurry seal shall be measured by and paid for per square yard.

Slurry seal shall not be placed when the atmospheric temperature is below 70 degrees F. (between placement and curing), during unsuitable weather, after 1:00 p.m., or between November 15th and April 30th. Due to seasonal conditions, the slurry seal work may have to wait until late spring. Under these circumstances, the Contractor shall continue to maintain insurance and bond requirements. The retention money will be held until all work is complete and no partial release of the retention will be allowed.

Before placing the slurry seal, the pavement surface shall be cleaned by sweeping, flushing or other means necessary to remove all loose particles of paving, all dirt and all other extraneous material.

Immediately prior to commencing the slurry seal operations, all surface metal utility covers (including survey monuments) and pavement markers shall be protected with appropriate adhesive and oiled or plastic paper. No adhesive material shall be permitted to cover, seal or fill the joint between the frame and cover of the structure. Covers and markers are to be uncovered and cleaned of slurry material by the end of the same work day.

If necessary, the Contractor may pre-wet the existing surface immediately prior to the application of the slurry seal with water at the rate of 0.05 to 0.10 gallon per square yard of surface as approved by the Engineer.

4102.17

Preservation of Existing Cobblestone Curbs and Gutters. Existing cobblestone curbs and gutters shall be preserved "in place" and shall not be disturbed unless otherwise directed, in writing, by the Director of Engineering and/or Director of Public Works.

A. PRESERVATION OF EXISTING COBBLESTONE CURBS AND/OR GUTTERS

In City street areas of reconstruction involving existing City street curbs and/or gutters where existing curbs and/or gutters are constructed of cobblestone, the cobblestone structures shall be retained as described herein:

1. Conditions and Tolerances for Existing Cobblestone: If the existing "exposed" curb and/or gutter face and/or top of curb is true to line and grade within one-fourth (1/4") inch in ten (10') linear feet, relative to the existing structure, and if there are no visible gaps between the stones that exceed one-fourth (1/4") inch and further if the stones are stable, i.e., can withstand a 200 pound concentrated load directed against any one stone at any horizontal or downward angle for a period of no less than five minutes, and if there is no unevenness from stone, exposed, surface to adjacent stone, exposed, surface that exceeds one-fourth (1/4") then the cobblestone curb and/or gutter is to be retained "as is", undisturbed, "in place" except that cobblestones may be removed

and salvaged and delivered to the City where new driveways or wheelchair ramps are to be constructed.

2. Where the existing cobblestone does not meet the above tolerances and where minor, less than one-half inch (1/2") in any direction, adjustments of the stones will correct the alignment and where the existing visible gaps between adjacent stones do not exceed one (1") inch and the exposed surface unevenness between adjacent stones does not exceed one-half (1/2") inch and further, if no more than three adjacent stones require adjustment, then the structure may be corrected in accordance with the Street Standard Details Drawing No. 216 entitled, "Retention of Cobblestone Curbs and/or Gutters, Minor Reconstruction".
3. Where the existing cobblestone does not meet the tolerances in Items 1 and 2 above, then the structure shall be corrected in accordance with these specifications and Street Standard Details Drawing No. 216 entitled, "Retention of Cobblestone Curbs and/or Gutter, Major Reconstruction".

Where existing cobblestone gutter is overlaid with asphalt concrete the contractor shall remove the asphalt, salvage and deliver the gutter stone to the City and replace the gutter with standard City P.C.C. gutter and overlay with asphalt "in kind".

4. Removing & Salvaging Cobblestones: This work shall conform with the applicable portions of Section 15, "Existing Highway Facilities" of the State Standard Specifications as modified herein:
 - a. Cobblestone Curb: Prior to disturbing any curb cobblestone, the curb stones to be removed and salvaged shall be consecutively numbered on the stone with crayon. All curb stones shall be hand removed. No metallic, Portland cement concrete, asphalt concrete, stone or gravel material shall come in contact with the curb stone. No metal tool, equipment or implements shall be used to pry, loosen, move or lift the curb stones. All curb stone removal and salvaging shall be done by hand and with wooden or hard rubber tools. All removable marks of any kind imposed on the curb stone exposed face or top by the contractor shall be removed by soft cloth and water, hand rubbing. All earth shall be hand-water-washed from the curb stone. All mortar shall be hand removed by wooden or hard, rubberized tools. Recrayon the number on exact stone after washing, if required.

- b. Cobblestone Gutter: The contractor may remove and salvage the cobblestone gutter in any convenient manner that results in the saving of the cobblestone undamaged. Gutter stone need not be washed or cleaned. Any type equipment and tools may be used provided no damage is done to the gutter stone except that the adjacent gutter stone in contact with cobblestone curb shall be removed as described in 4-A, "Cobblestone Curb", above, except gutter stone does not require numbering.

5. Temporary or Permanent Storing of Cobblestone:

- a. Curb Stone: Curb stone shall be hand lifted and placed flatwise on three-quarter (3/4") inch maximum thickness plywood. No curb stone shall be on contact with any substance other than plywood. The curb stone shall have a minimum of three (3") inches and a maximum of six (6") inches horizontal clearance between stored stone. Curb stone may be stored in progressive vertical layers with three-quarter (3/4") inch plywood sandwiched between each layer up to and including four (4') of vertical feet height. The contractor shall be responsible for all stored cobblestone until delivery and permanent storage at the City Corporation Yard.
- b. Gutter Stone: Gutter stone may be temporarily, equipment-piled on approved City right-of-way out of the traveled way on any approved surface convenient to the contractor which is made safe for pedestrians and vehicular traffic with approved barricades. Permanent storage shall be in piles on the ground as designated by the Engineer at the City, Street, Corporation Yard. Gutter stone may be lifted and piled with any equipment convenient to the contractor which will not damage City streets or gutter stone.

6. Loading, Transporting & Unloading of Cobblestone:

- a. Curb Stone: Curb stone to be delivered to the City Corporation Yard shall be hand lifted, loaded and placed in layers, flatwise on three-quarter (3/4") inch minimum plywood mats between the stone on the bed of a flatbed truck. Dump trucks shall not be used to transport cobblestone curb.

The stone shall not be in contact with other stones or any metal portion of the truck. The stone may be sandwiched

in layers of plywood up to but not to exceed the legal weight limit of the vehicle or in any case not above four (4) horizontal layers of stone. Curb stone shall be hand lifted, unloaded and placed on plywood as detailed on "storing curb stone". Curb stone shall not be chipped, dropped, scratched or damaged by the contractor.

- b. Gutter Stone: The contractor may load, haul and unload gutter stone in any convenient manner that will not damage the stone.
7. Clear, Grub & Concrete Removal: Shall conform with Clause 4102.1 of the City of Petaluma Street Construction Detail Specification No. 41. The contractor shall not clear, grub or remove PCC gutter until all cobblestone is removed.
- a. Tree Root Treatment: Where tree roots have displaced cobblestone curb and/or gutter, the contractor shall remove and seal the roots and install a root barrier as shown on the Street Standard Details Drawing No. 216 entitled, "Treatment for Tree Roots".
 - b. Existing PCC Gutter Removal is included in this item.
8. Excavation for Cobblestone Curb & Gutter: Shall conform with Clause 4102.2 of the City of Petaluma Street Construction Detail Specification No. 41. All excavation shall be loaded directly onto trucks and disposed of by the contractor. The contractor shall not excavate until all cobblestone is removed.
9. Aggregate Base: Base rock shall conform with Clause 4102.4 of the Detail No. 41 Specifications. All aggregate base shall be Class 2, three-quarter (3/4") inch minus compacted to ninety-five (95%) percent at optimum moisture content.
10. Portland Cement Concrete Gutter: Shall conform with Clause 4102.8 of the No. 41 Detail Specifications. PCC gutter shall not be placed until all cobblestone gutter is reset and the concrete foundation has cured seven (7) days.
11. Cement Mortar: Shall conform with Paragraph 51-1.135 Mortar of the State of California Standard Specifications dated July 1984, except that mortar exposed to view shall have one (1 oz.) ounce of lamp black added to each cubic foot of mortar.

B. RESETTING COBBLESTONE:

1. Tolerances: Reset cobblestone shall be within the following tolerances:
 - a. Reset Cobblestone Curb: Horizontal and vertical within one-eighth (1/8") inch of line and grade in ten (10') linear feet. Individual stone face or top must not vary beyond one-sixteenth (1/16") inch from the adjacent stone face or top, respectively. Individual curb stone shall not vary more than one-sixteenth (1/16") inch per foot from plumb or vertical.
 - b. Cobblestone Gutter: Gutterstone shall be set flat and true and not vary from line and grade more than one-fourth (1/4") inch in ten (10') linear feet. Individual stones surfaced shall not vary more than one-eighth (1/8") inch from any adjacent gutter stone surface.
2. Reset Curb Stone: Stone shall be reset in accordance with the plans and specifications. Each curb stone shall be reset in the same numerical order and to the same face and top orientation as the original curb. Each stone shall be set in a concrete foundation as shown on the Street Standard Details Drawing No. 216 entitled, "Retention of Cobblestone Curbs and/or Gutters, Major Reconstruction". The concrete foundation shall be five sack Portland cement concrete in conformance with Section 90-10 Minor Concrete of the State Standard Specifications. The aggregate size for the foundation shall not exceed three-quarters (3/4") inch. Slump for foundation concrete shall not exceed two and one-half (2 1/2") inches. Curing of concrete foundation shall be in accordance with Paragraph 90-7.01 Curing Compound Method of the State Specifications. Water shall not be used to cure the foundation concrete due to the possibility of supersaturation and softening of the subgrade. Concrete foundation shall cure for seven (7) days prior to installing the gutter if the foundation and gutter are placed separately. All joints of reset curbstone shall be mortared.
3. Reset Gutter Stone: Stone shall be reset in accordance with the plans and specifications. Gutter stone shall be bedded a minimum of two (2") inches deep and a maximum of four (4") inches deep in a one (1) part cement to two (2) parts sand. Installation of mortar shall conform with Paragraph 51-1.135 Mortar of the State Standard Specifications. Gutter stone mortar shall be water cured using continuously wetter cotton mats, burlap sack or other approved wetted material all in conformance with Paragraph 90-

7.01A Water Method of the State Standard Specifications except that earth blankets shall not be used. Curing compound shall not be used to cure mortar in cobblestone gutter due to the possibility of discoloration of the cobble. Gutter mortar shall cure seven (7) days prior to opening gutter to traffic.

Subgutter concrete shall be five (5) sack, one (1") inch maximum aggregate conforming with Section 90-10 Minor Concrete of the State Standard Specification. Subgutter concrete, i.e., four (4") inch concrete slab under cobblestone paved gutter shall a four (4") inch maximum slump, shall be compound cured in conformance with Paragraph 90-7.01B Curing Compound Methods of the State Standard Specifications.

Water shall not be used to cure subgutter concrete.

Detail41