

INFILTRATION TRENCH SECTION VIEW
NTS

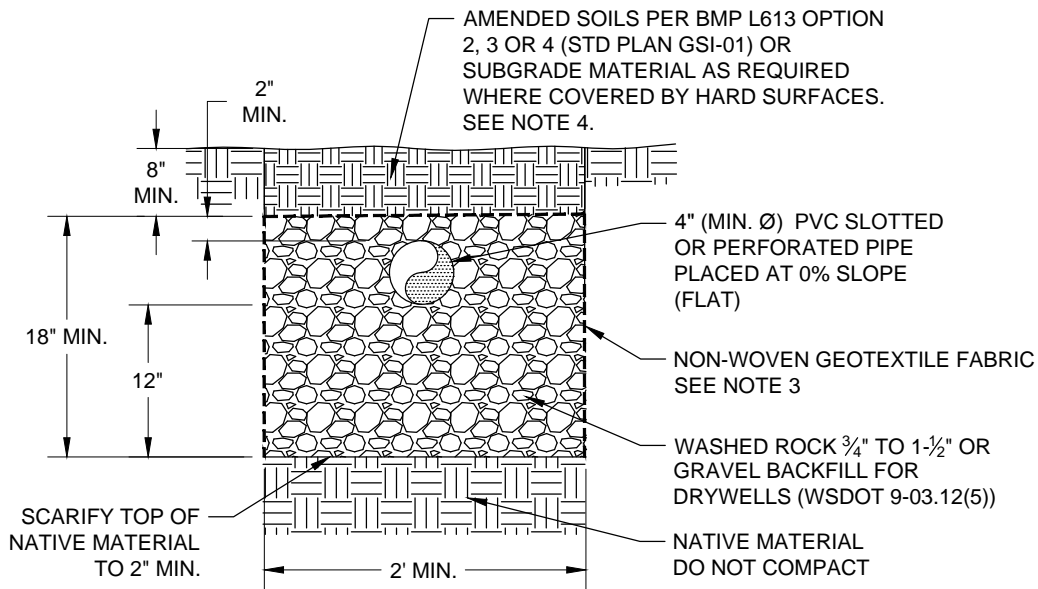

INFILTRATION TRENCH SECTION VIEW
NTS

NOTES:

1. Cleanouts recommended at pipe bends and end of trench.
2. Solid lid yard drain or catch basin shall be designed to be traffic bearing in areas subject to traffic.
3. Place non-woven geotextile fabric along walls and top of washed rock. Non-woven geotextile to conform to WSDOT Spec. 9-33.2(1), Tables 1 and 2.
4. All disturbed areas not covered with hard surfaces shall be stabilized by planting or mulching.



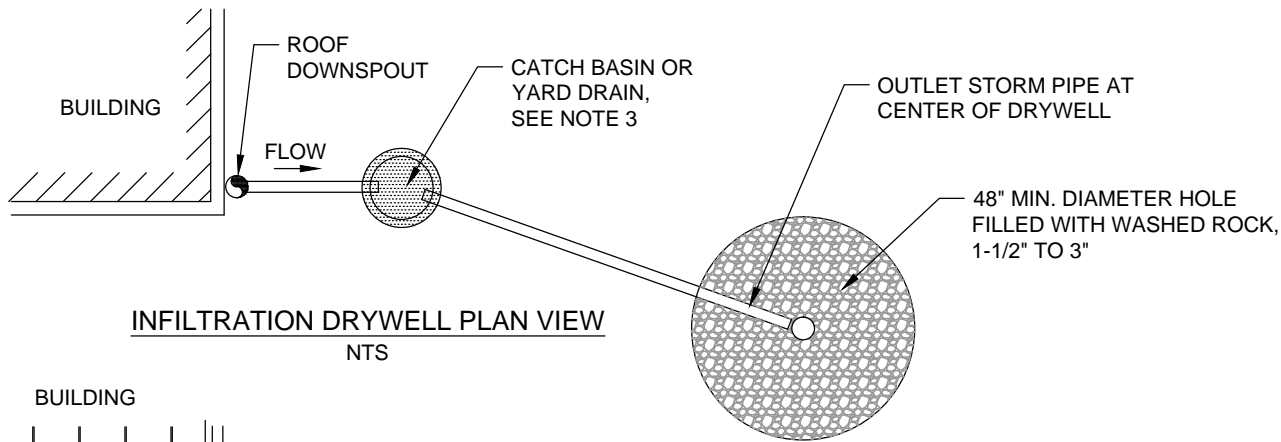

INFILTRATION DRYWELL PLAN VIEW
NTS

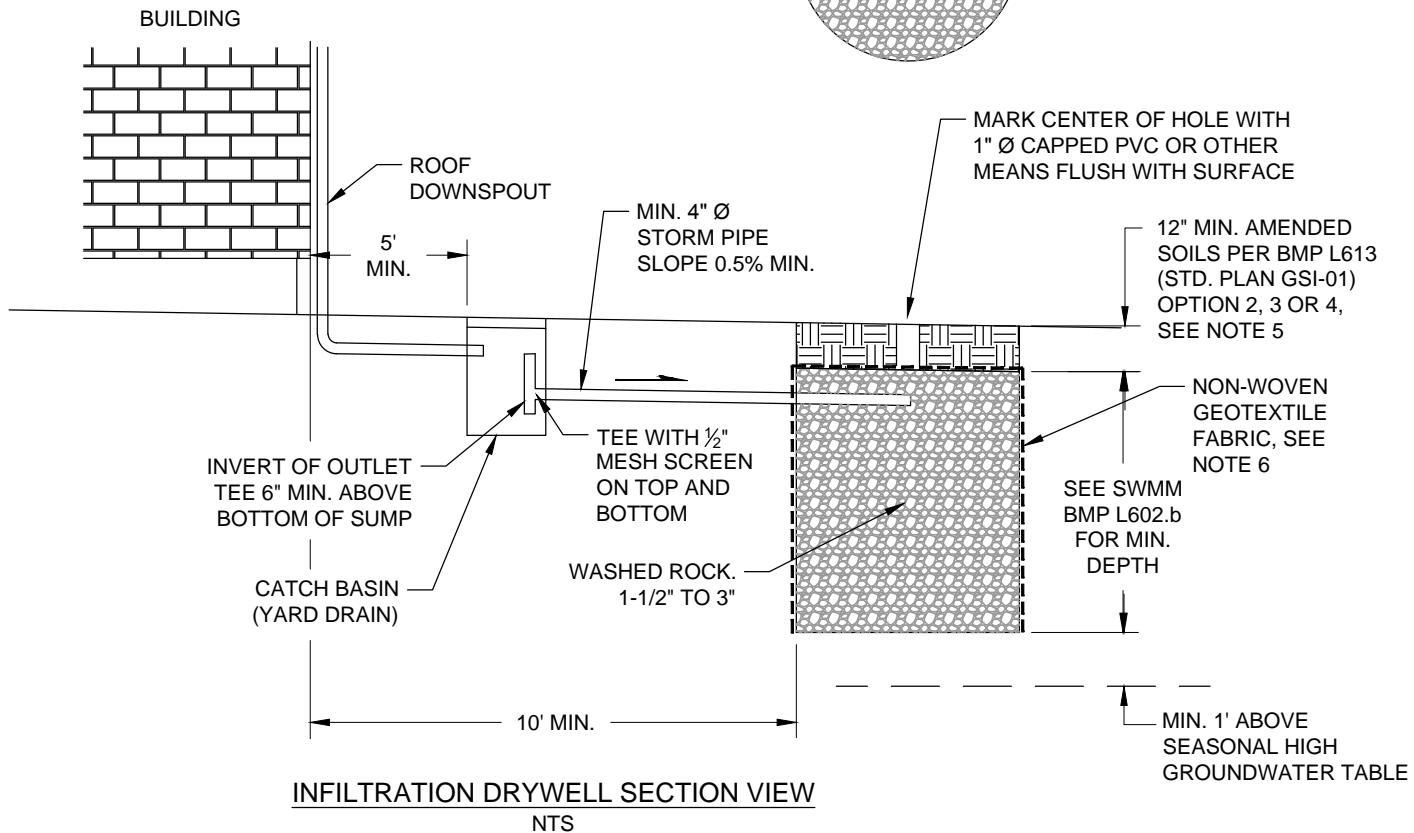

INFILTRATION DRYWELL SECTION VIEW
NTS

NOTES:

1. Sizing per SWMM BMP L602b.
2. Cleanouts recommended at any pipe bends.
3. Solid lid yard drain or catch basin shall be designed to be traffic bearing in areas subject to traffic.
4. For amended soils guidance, see Standard Detail BMP L613 Options 2, 3 or 4 (Std. Plan GSI - 01).
5. All disturbed areas not covered with hard surfaces shall be stabilized by planting or mulching.
6. Place non-woven geotextile fabric along walls and top of washed rock. Non-woven geotextile to conform to WSDOT Spec. 9-33.2(1), Tables 1 & 2.



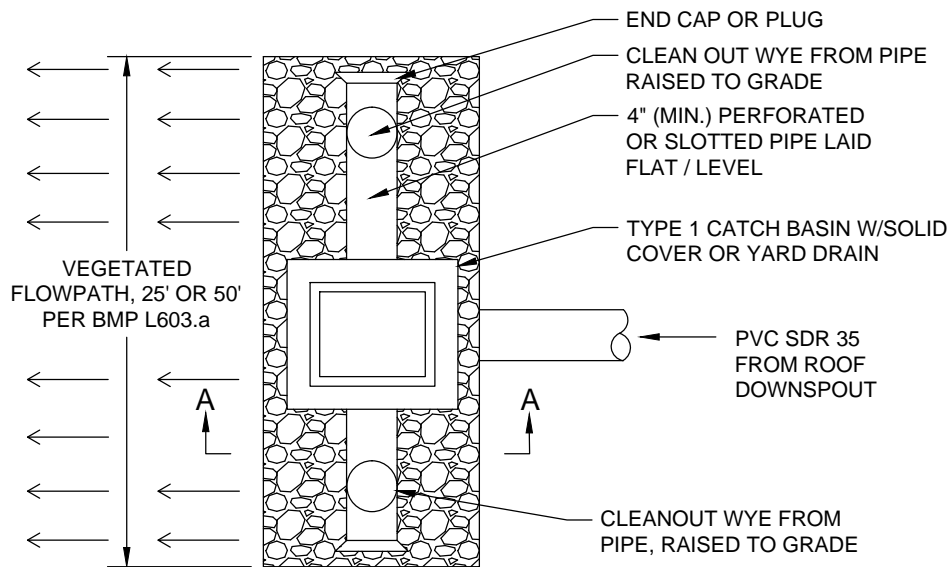

PLAN
NTS

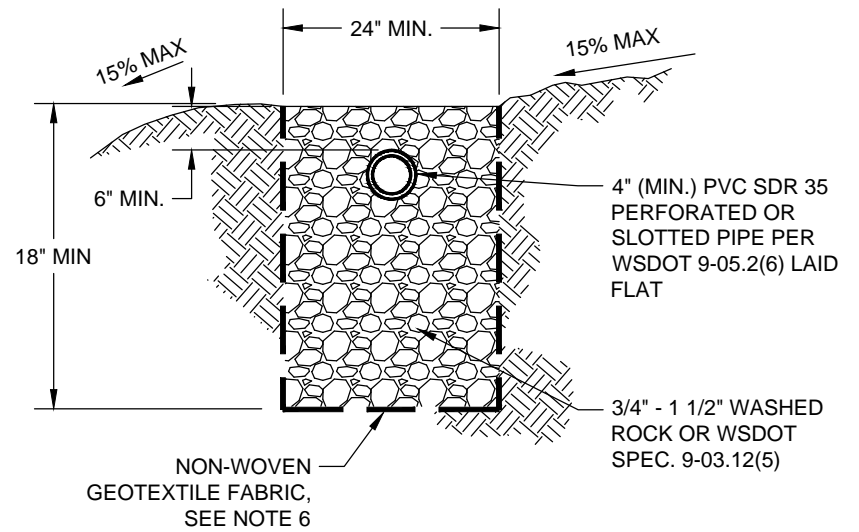

SECTION A-A
NTS

NOTES:

1. Trench may be placed no closer than 10 feet to another (100 feet along flowpath)
2. Trench must be level. Align to follow contours on site.
3. Trench may serve roof areas up to 700 square feet. For larger roof areas, refer to GSI Figure No. 004 - Dispersion Trench with Notched Grade Board.
4. Refer to SWMM BMP L603.a.
5. Trench length not to exceed 10 feet.
6. Place non-woven geotextile fabric along walls and bottom of washed rock. Non-woven geotextile to conform to WSDOT Spec. 9-33.2(1), Tables 1 and 2.

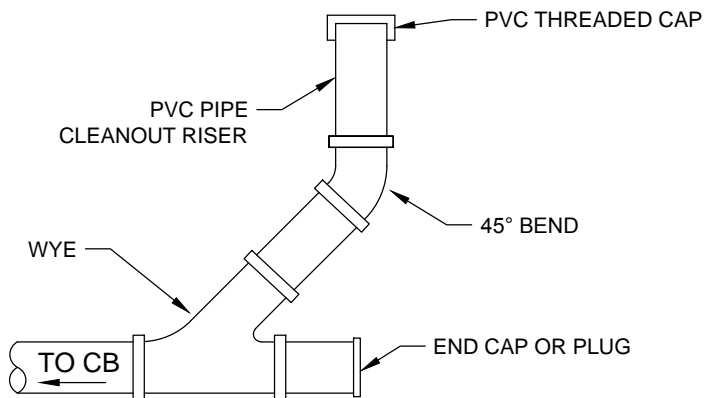

CLEANOUT SECTION
NTS



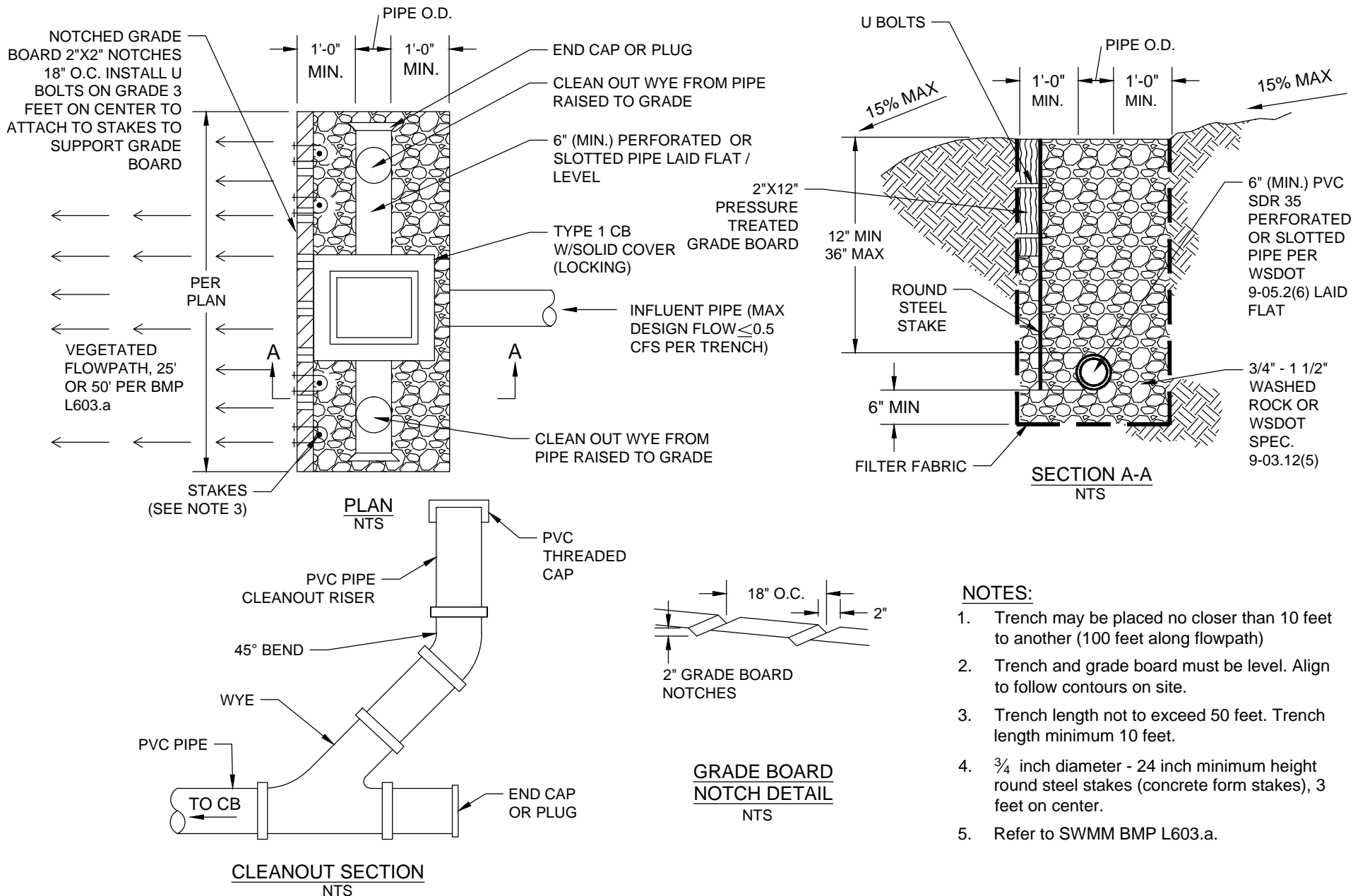

NOTES:

1. Trench may be placed no closer than 10 feet to another (100 feet along flowpath)
2. Trench and grade board must be level. Align to follow contours on site.
3. Trench length not to exceed 50 feet. Trench length minimum 10 feet.
4. 3/4 inch diameter - 24 inch minimum height round steel stakes (concrete form stakes), 3 feet on center.
5. Refer to SWMM BMP L603.a.



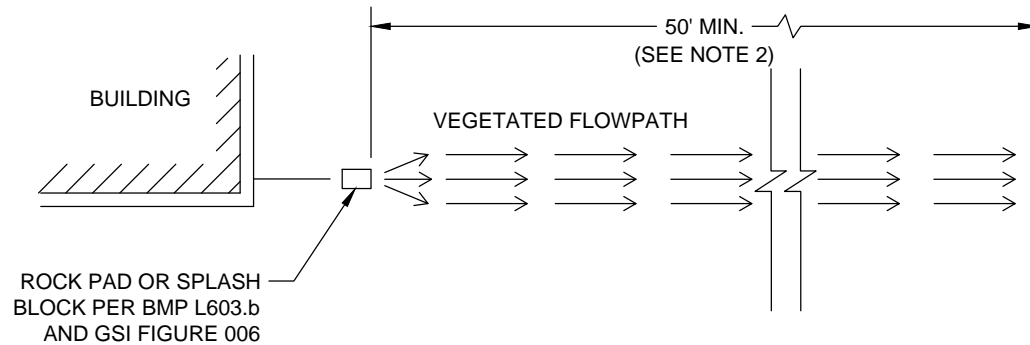
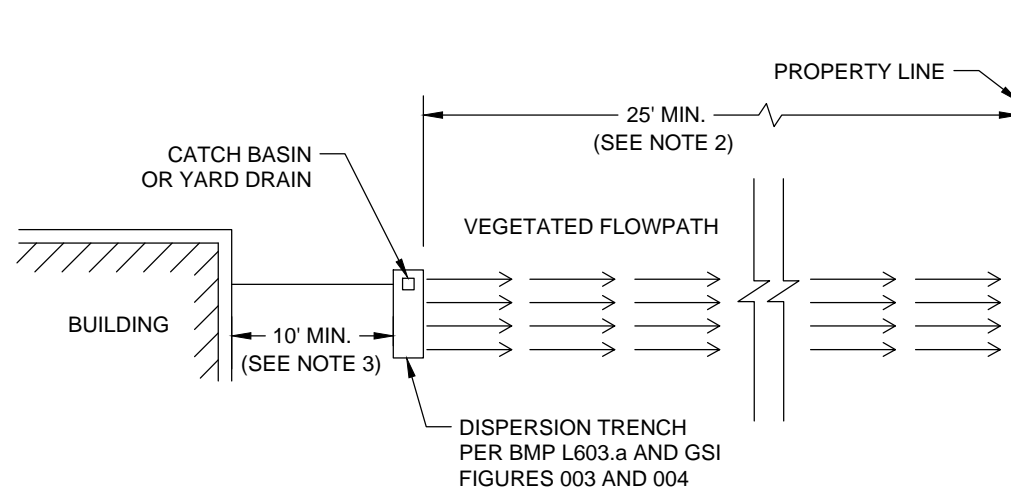

NOTES:

1. Per BMP L603.a, sensitive area buffers may count towards flowpath lengths if approved by the City of Tacoma.
2. Vegetative flowpath is measured from the downspout or dispersion system discharge point to the downstream property line, stream, wetland, or other hard surface. The vegetative flowpath shall be measured perpendicular to site contours. A vegetated flow path of at least 50 feet in length must be maintained between the outlet of the trench and any slope 15 % or greater.
3. The discharge point shall be at least 10 feet from any building structure and at least 5 feet from any other structure or property line unless approved by Environmental Services. If necessary, setbacks shall be increased from the minimum 10 feet in order to maintain a 1H:1V side slope for future excavation and maintenance.
4. Additional setbacks may be required by other local, state, or federal agencies. Where a conflict between setbacks occurs, the City shall require compliance with the most stringent of the setback requirements from various codes/regulations.



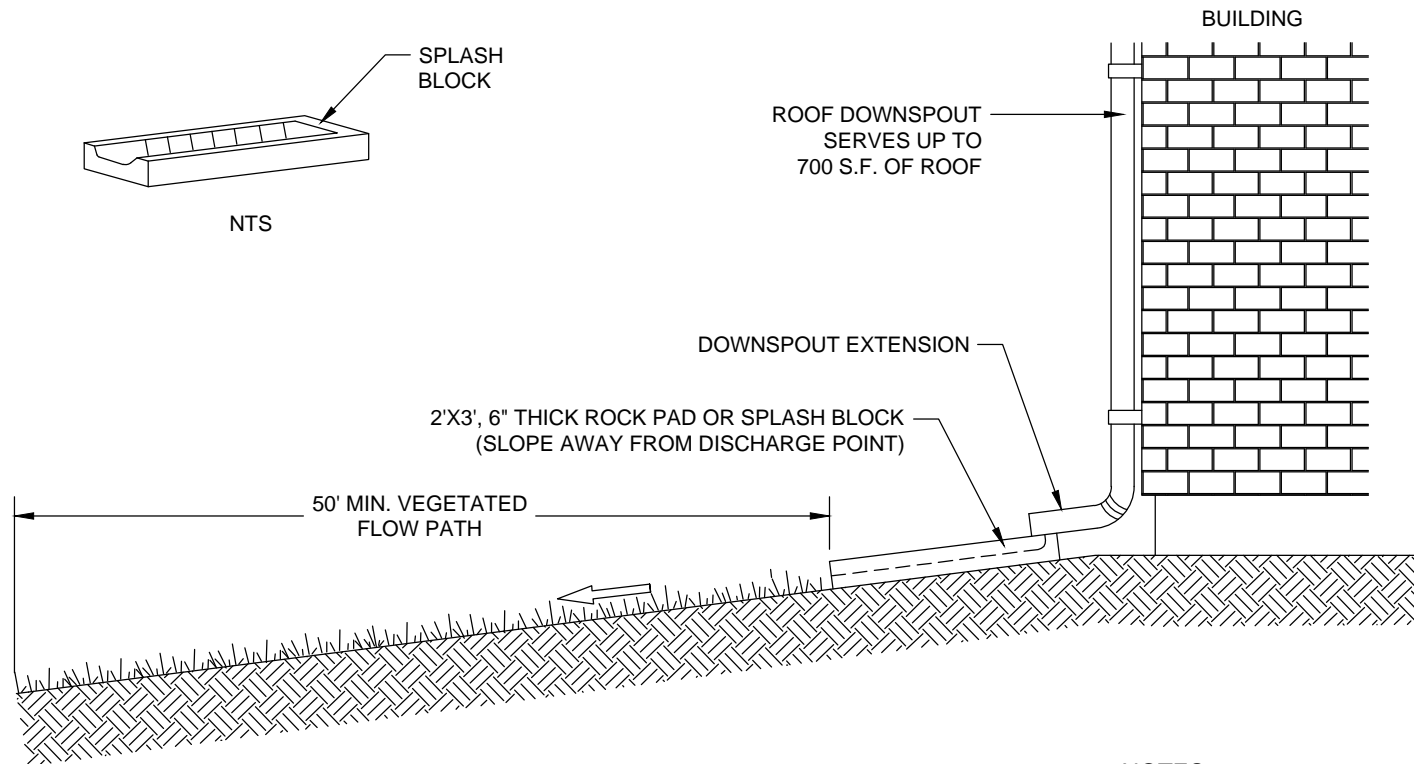

NOTES:

1. Refer to Stormwater Management Manual BMP L603.b and GSI Figure 005 for setbacks.
2. Splash block shall be concrete, plastic, or similar material. Commercially available splash blocks generally meet design criteria.
3. Rock pad shall consist of 4" cobbles per WSDOT 9-03.11(2) or ballast meeting WSDOT 9-03.9(1).



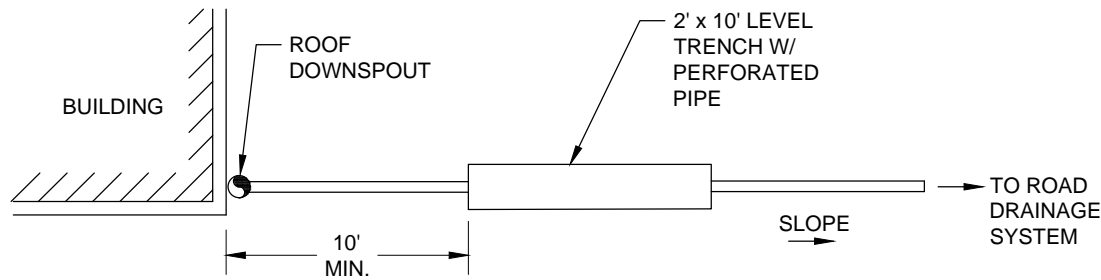

AMENDED SOIL PER BMP L613 OPTION 2, 3, OR 4, OR SUBGRADE MATERIAL AS REQUIRED WHERE COVERED BY HARD SURFACE. SEE NOTE 7.

PLAN VIEW OF ROOF
NTS

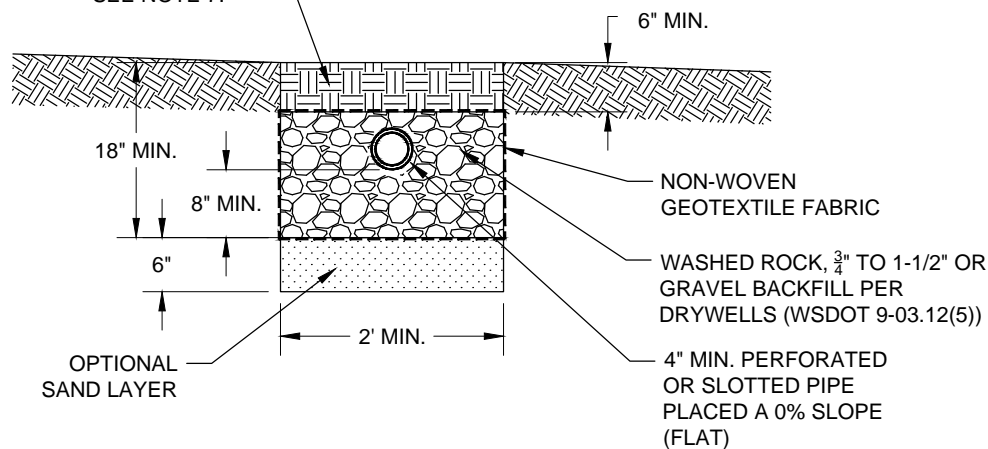

PERFORATED STUB-OUT SECTION
NTS

NOTES:

1. Provide 10 feet of perforated pipe per 5,000 square feet of roof area laid in a level, 2-foot wide trench.
2. 3/4" - 1 1/2" washed rock or WSDOT Specification 9-03.12(5).
3. Place non-woven geotextile fabric along walls, bottom, and top of washed rock. Non-woven geotextile to conform to WSDOT Spec. 9-33.2(1), Tables 1 and 2.
4. A minimum one foot of separation is required from the trench bottom to the seasonal high ground water.
5. Perforated stub-out to be sized and located per SWMM BMP L604.
6. Do not build on slopes steeper than 20%.
7. All disturbed areas not covered with hard surfaces shall be stabilized by planting and mulching.
8. Cleanouts recommended at pipe bends and one end of the perforated section.



**CITY OF TACOMA
GREEN STORMWATER INFRASTRUCTURE
TYPICAL DETAILS**

PERFORATED STUB-OUT CONNECTION

FIGURE NO.

007

January 2016

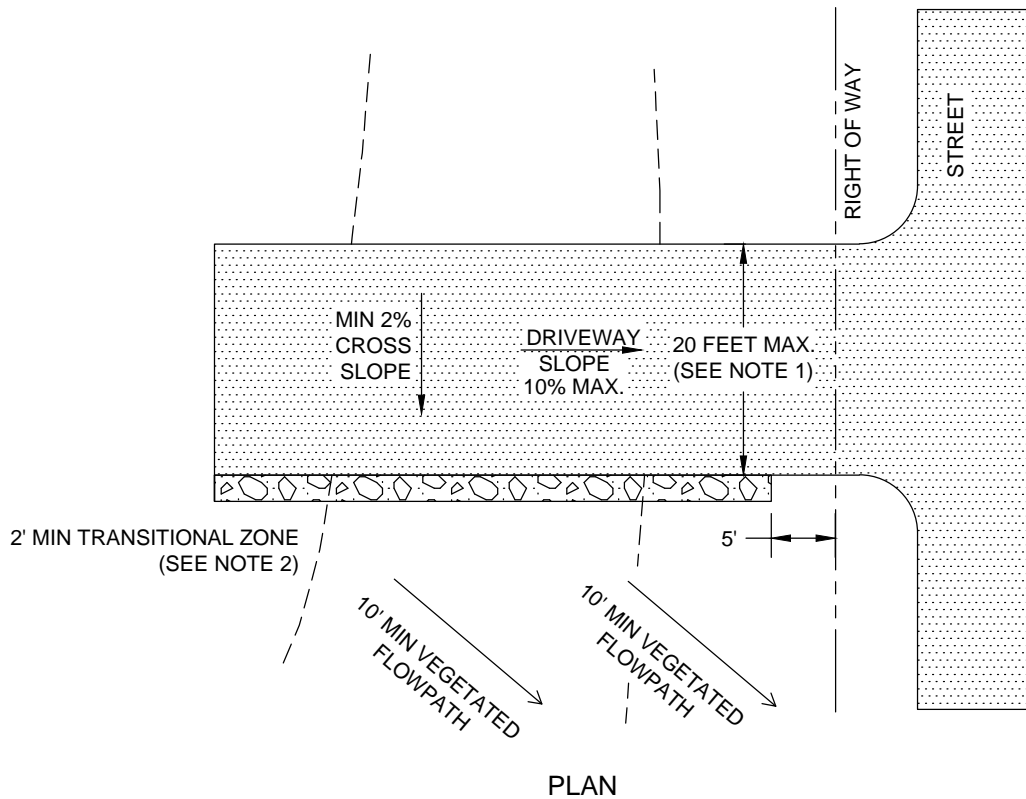

NOTES:

1. For driveways greater than 20 feet in width, additional flow path is required. See SWMM BMP L612.
2. Transition zone material may be crushed rock, modular pavement, drain rock or other material approved by the City.
3. Dispersion systems shall set back a minimum 10 feet from buildings and a minimum of 5 feet from property line unless approved in writing by the City.
4. Dispersion systems shall be set back a minimum of 50 feet from the top of any steep (greater than 15%) slope.



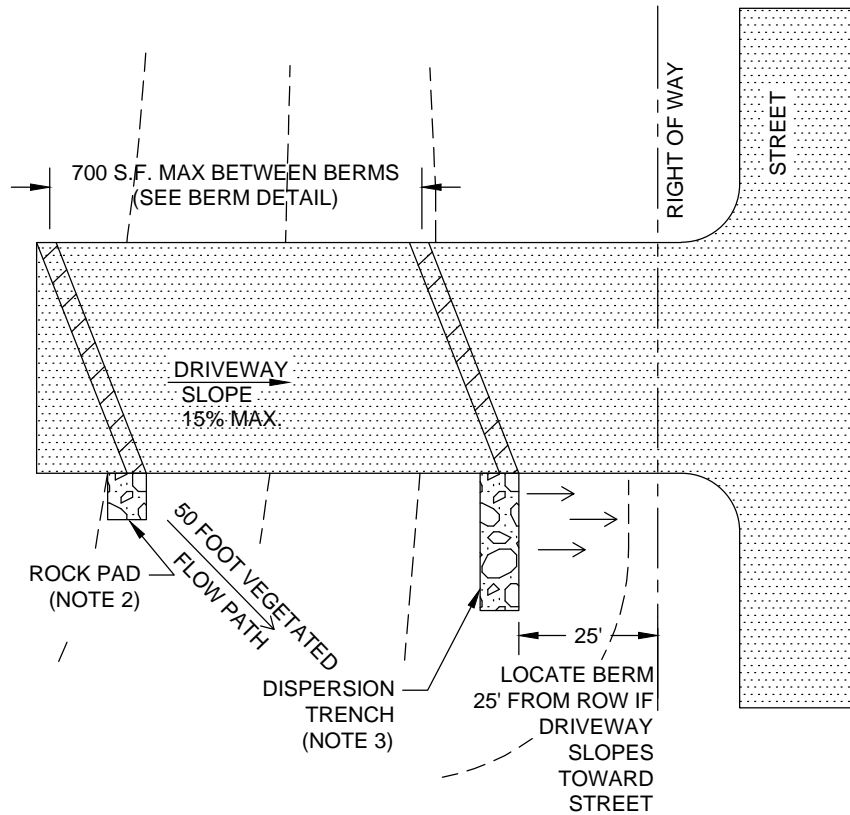

PLAN
DRIVEWAY WITH DIAGONAL BERMS

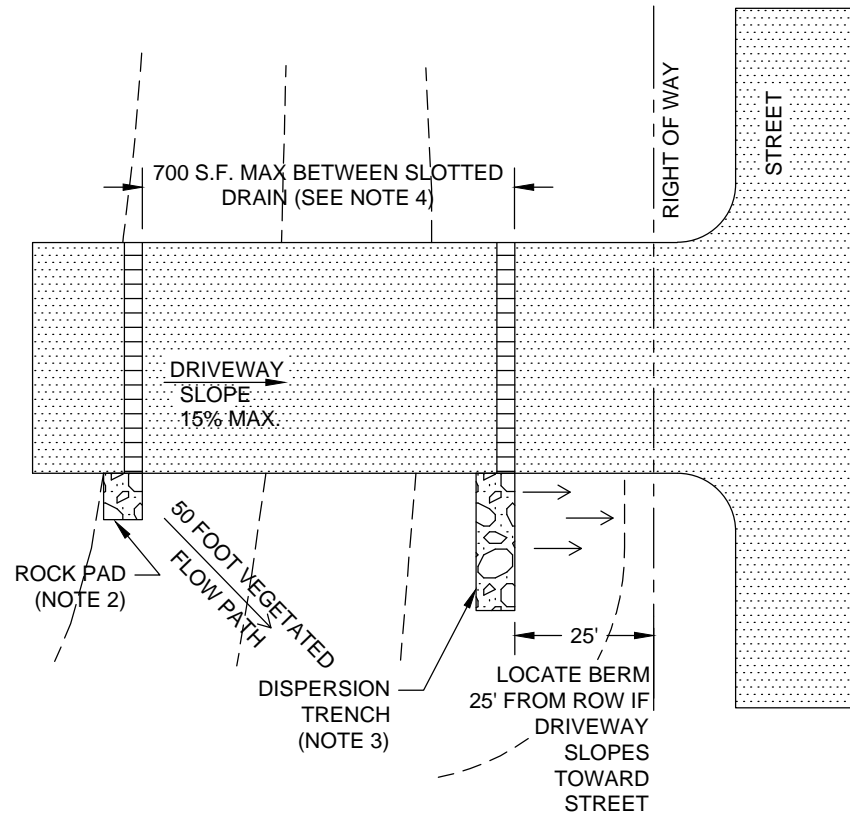

PLAN
DRIVEWAY SLOTTED DRAINS

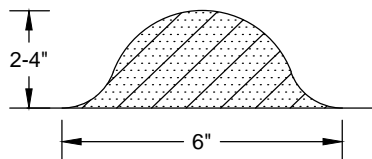

ASPHALT OR CONCRETE BERM DETAIL

NOTES:

1. See SWMM BMP L611 for additional requirements.
2. Rock pad shall be clean crushed rock or 4 inch cobbles per WSDOT 9-03.11(2), 2 feet wide by 3 feet long by 6 inches deep.
3. Dispersion trench shall conform to BMP L603.a and GSI Figure 003.
4. Berms or drains may be used to concentrate flow. Slotted drains shall be modular trench channel units for driveways with a minimum width of 4 inches.
5. Dispersion systems shall be set back a minimum of 10 feet from buildings.
6. Dispersion systems shall be set back a minimum of 50 feet from the top of any steep (greater than 15%) slope.



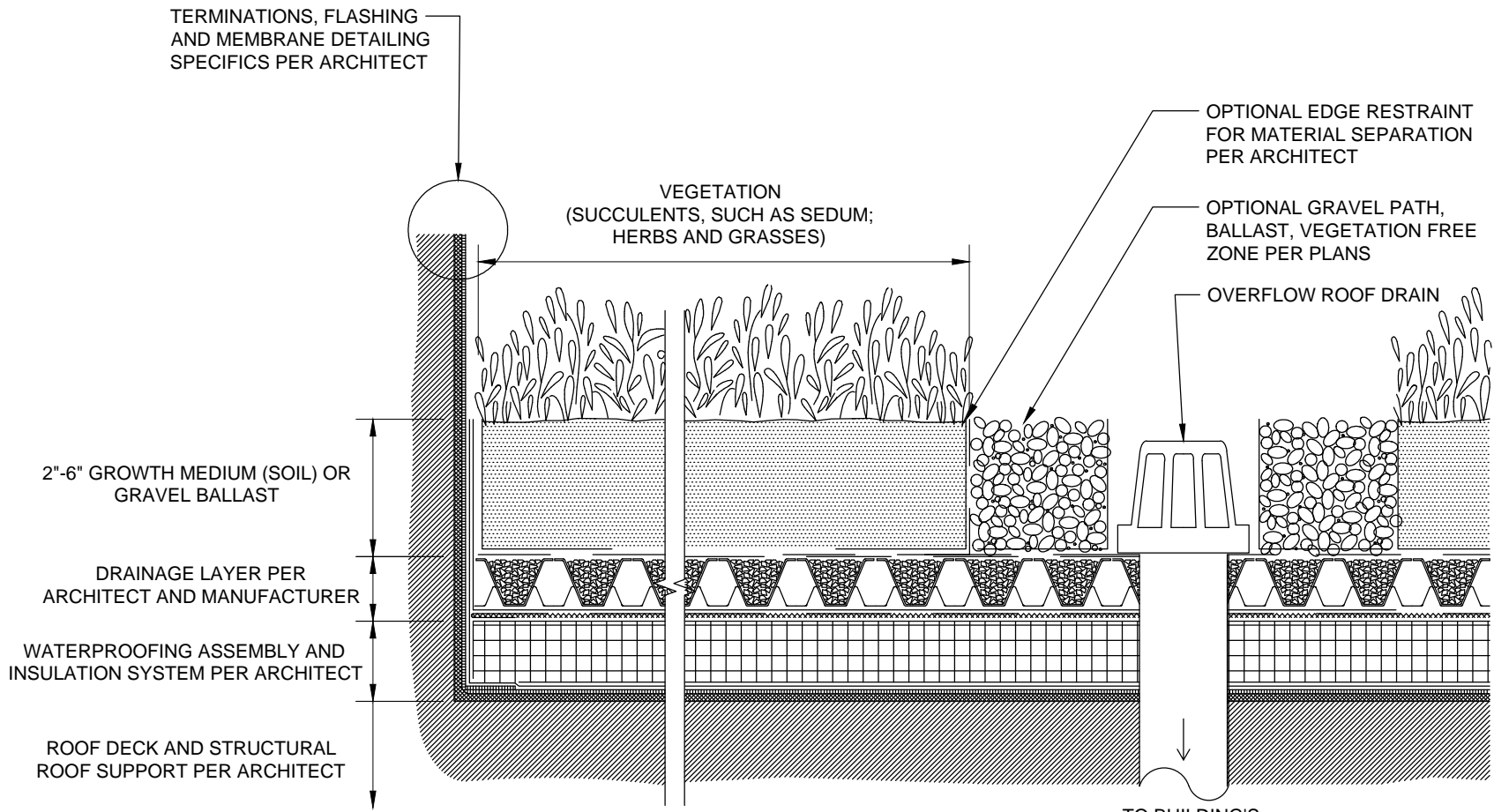

SECTION
NTS

NOTES:

1. This is a conceptual plan for an extensive vegetated rooftop. See SWMM BMP L631 for design requirements.



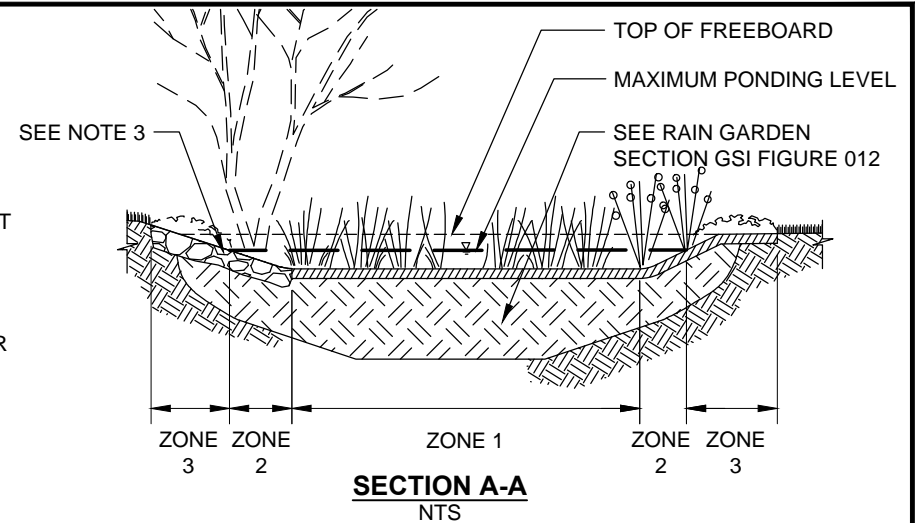
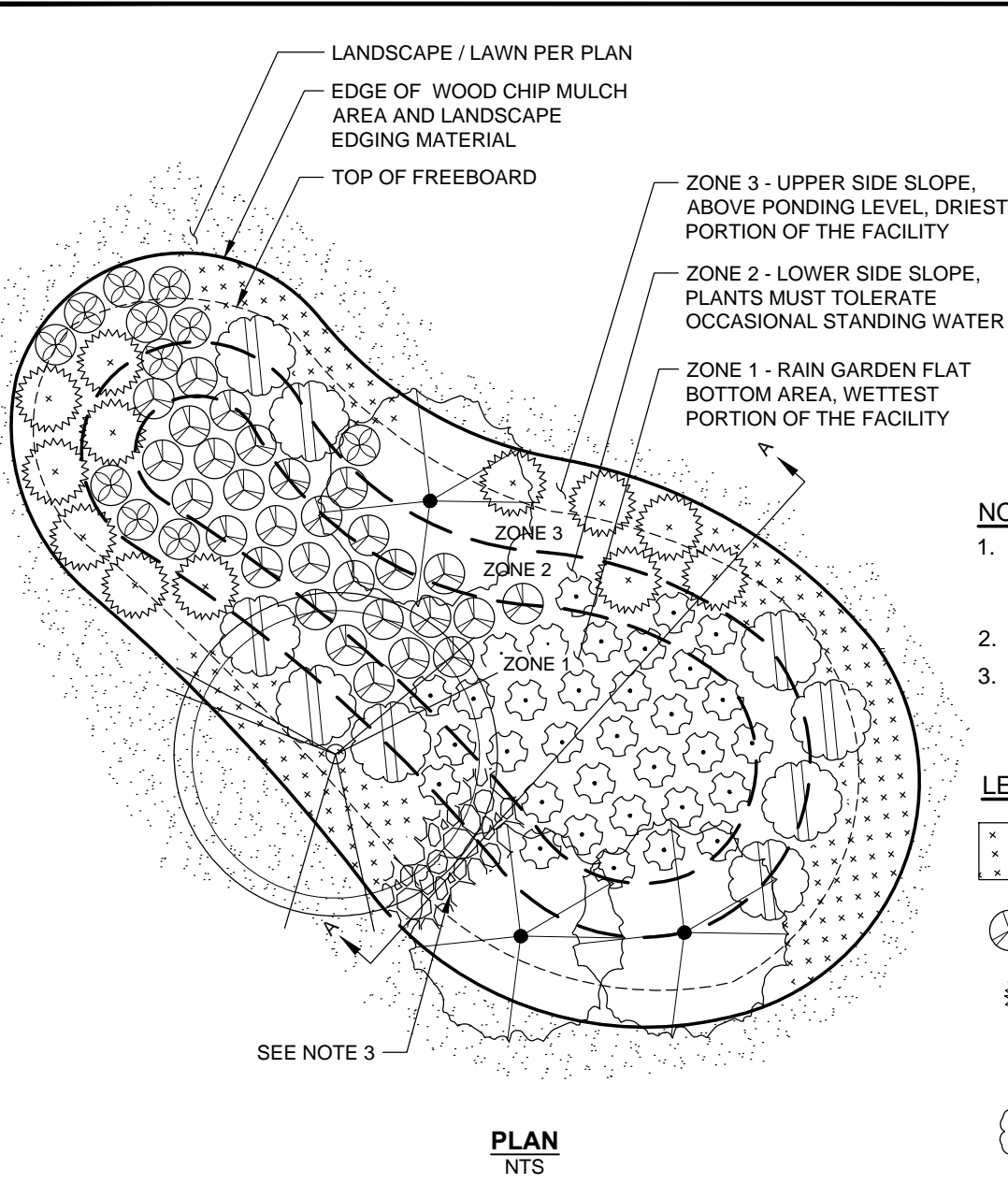

NOTES:

1. For guidance on plants for each zone and for example planting plans see the 2013 Rain Garden Handbook for Western Washington, available at CityofTacoma.org/raingardens.
2. Choose a minimum 50% evergreen plants.
3. Keep plants clear of inlet, outlet and/or overflows.

LEGEND:

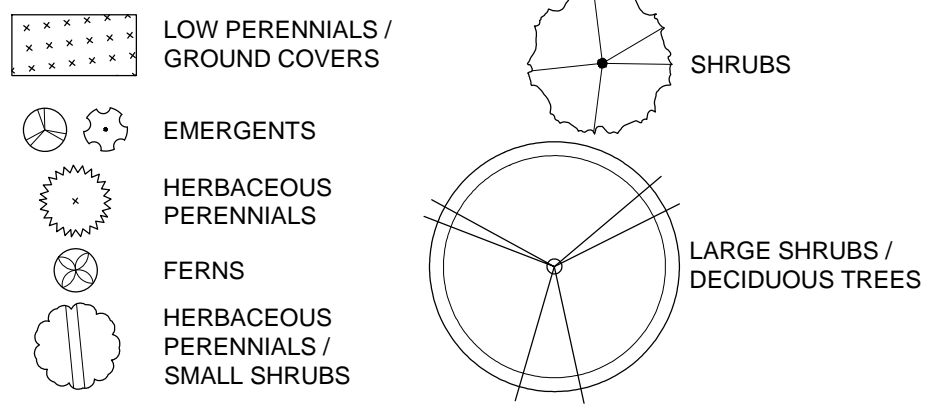

**CITY OF TACOMA
GREEN STORMWATER INFRASTRUCTURE
TYPICAL DETAILS**



RAIN GARDEN - PLANTING ZONES

FIGURE NO. 011

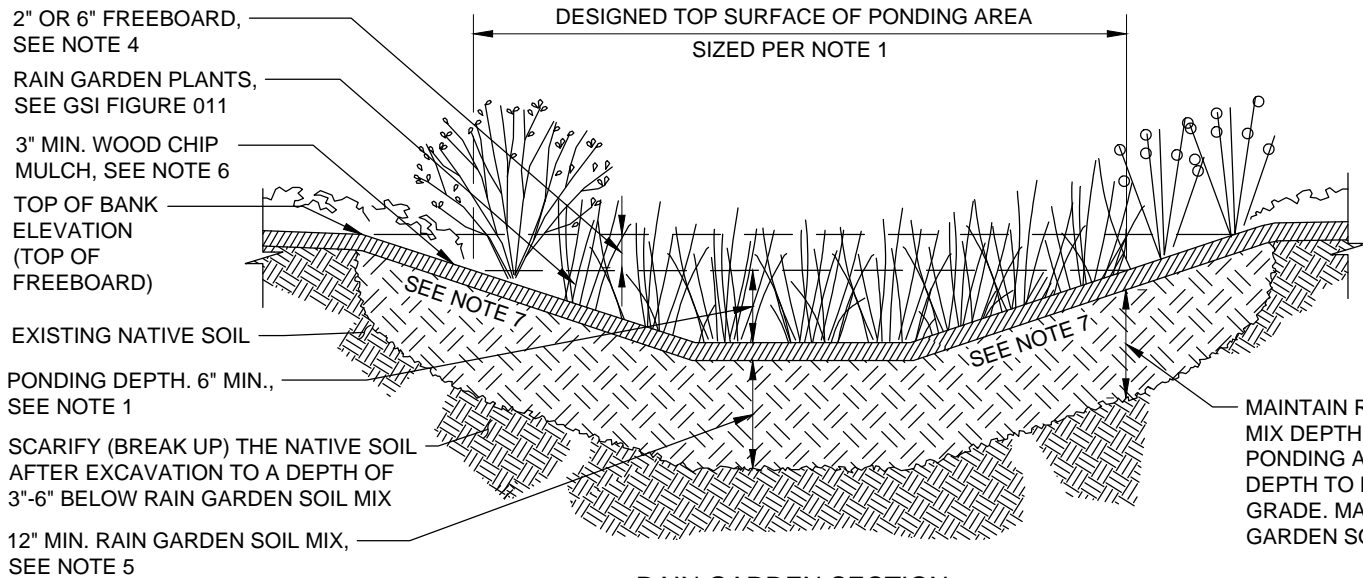
January 2016

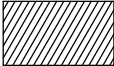

LEGEND:

-  RAIN GARDEN SOIL MIX
-  WOOD CHIP MULCH
-  EXISTING NATIVE SOIL

RAIN GARDEN SECTION
NTS

NOTES:

1. Rain gardens sized for compliance with MR #5 shall be in accordance with SWMM BMP L601, available at www.cityoftacoma.org/stormwatermanual. Rain gardens not required to comply with SWMM can be sized per the Rain Garden Handbook for Western Washington, available at cityoftacoma.org/raingardens - where sizing is based upon depth of either 6-inches or 12-inches of ponding.
2. Transition zone
 - a. 1-inch grade change from edge of sidewalk, curb and/or other hard surface.
 - b. 2% max. slope.
 - c. Transition shall be amended soils per BMP L613 (Std. Plan GSI-01) if applicable or per note 3.
3. Scarify or till subgrade to 3-inch depth. Place 3-inches of topsoil on surface and till into 5-inches of site soil. Install 3-inches woodchip mulch or as specified on plans.
4. Freeboard shall be a minimum of 2-inches for contributing areas under 1,000 square feet, or 6-inches for contributing areas 1,000 square feet or greater per SWMM.
5. Do not compact the rain garden soil mix.
 - a. Do not operate heavy equipment within the the rain garden.
 - b. Do not place or amend rain garden soil when the ground is frozen or when the soil is excessively wet.
6. Continue mulch for a minimum of 2-feet past the top of bank elevation or install landscape edging if rain garden is adjacent to turf.
7. Maximum side slope (2:1 or 3:1) varies with size of contributing area. See SWMM BMP L601 or the Rain Garden Handbook for Western Washington, as applicable.

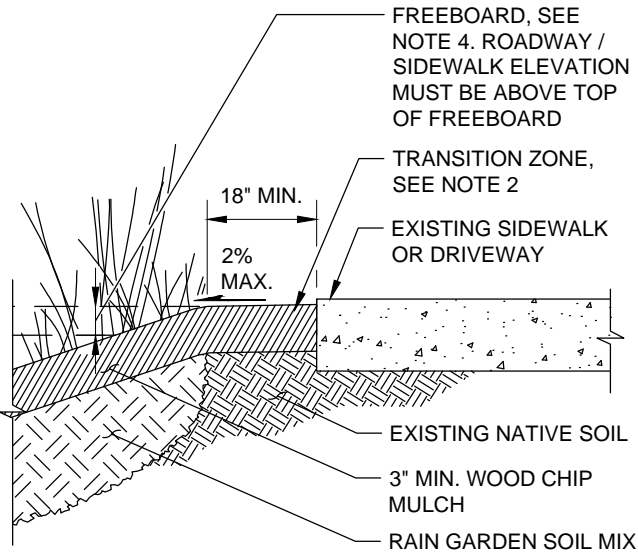

RAIN GARDEN ADJACENT TO SIDEWALK OR DRIVEWAY
NTS



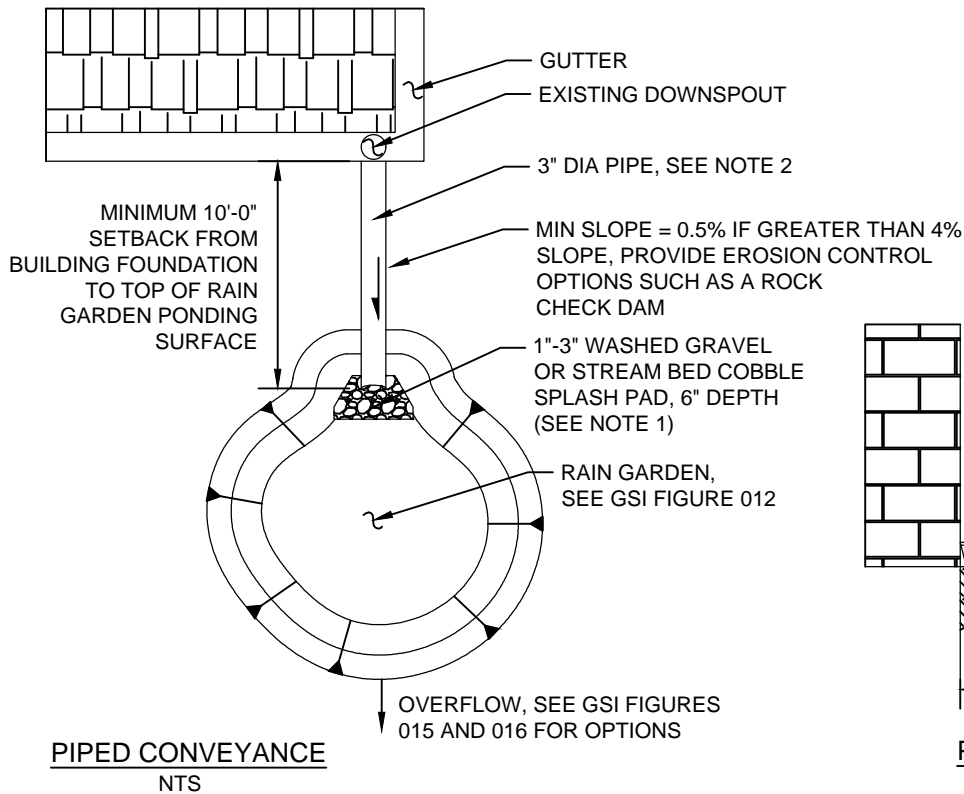

LEGEND:

	1"-3" WASHED GRAVEL OR STREAM BED COBBLE
	RAIN GARDEN SOIL MIX
	WOOD CHIP MULCH
	EXISTING NATIVE SOIL

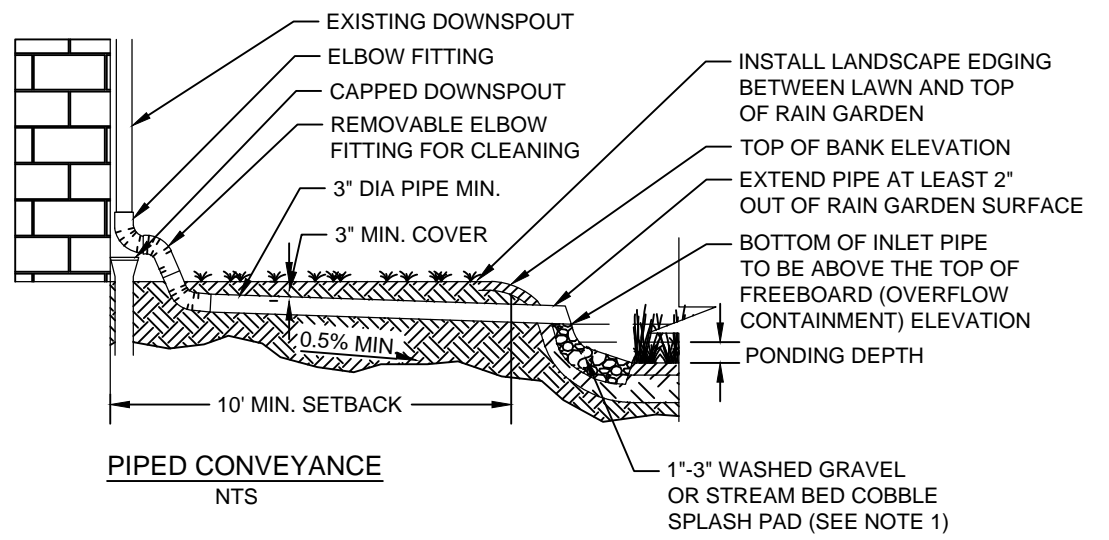

- NOTES:**
1. Gravel or stream bed cobble splash pad minimum depth of 6 inches. Rock splash pad shall be minimum of 1 foot wide and extend beyond the pipe outlet by a minimum of 1 foot.
 2. Pipe shall be per SWMM Volume 3.



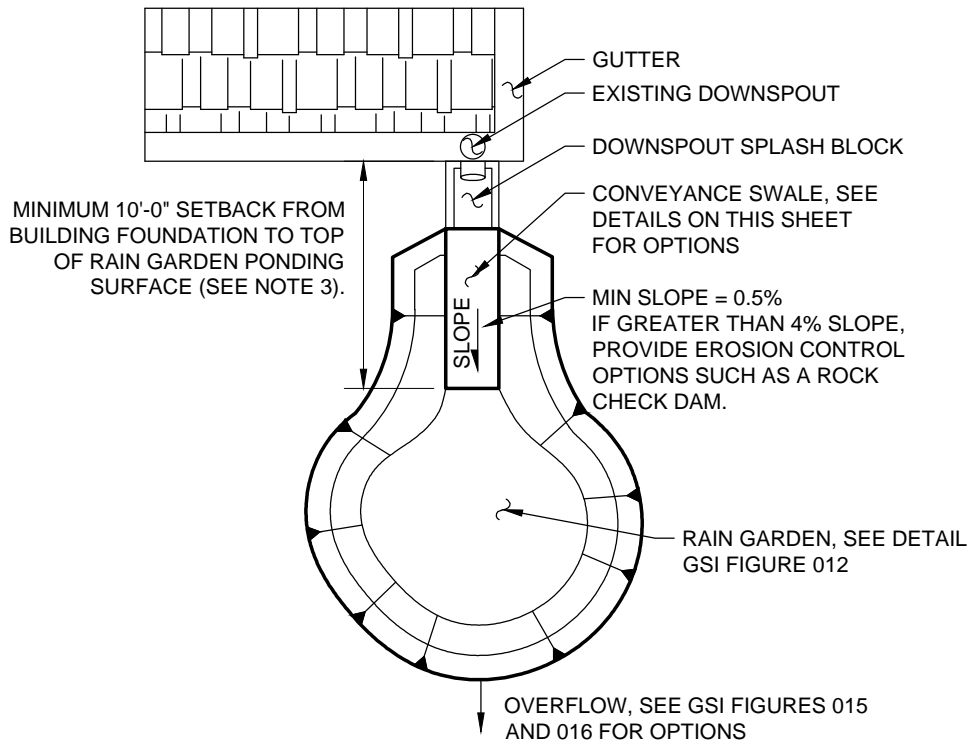

CONVEYANCE SWALE
NTS

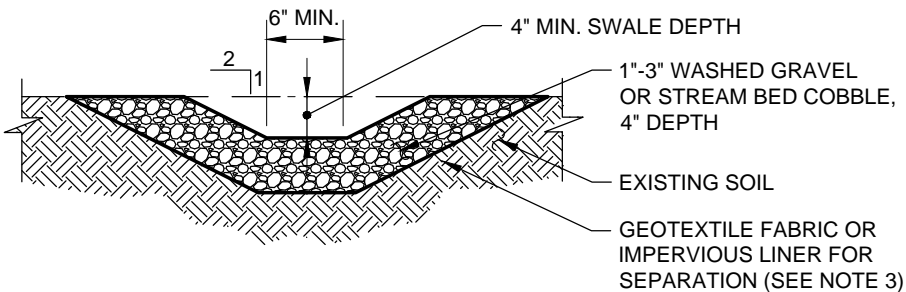

ROCK-LINED CONVEYANCE SWALE
NTS

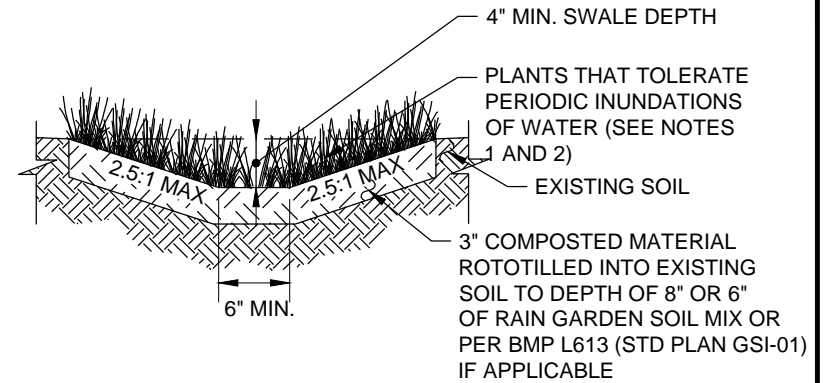
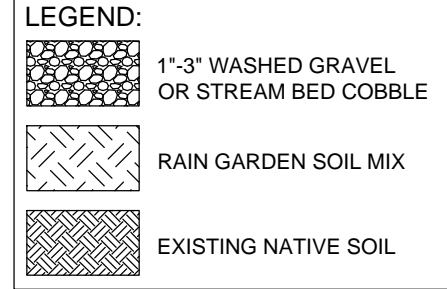

VEGETATED CONVEYANCE SWALE
NTS

NOTES:

1. Do not place plants that will restrict or concentrate the flow of water in the bottom of the swale.
2. Choose well rooted plants suitable for Zone 2 per 2013 Rain Garden Handbook for Western Washington, available at City of Tacoma.org/raingardens.
3. Use impervious liner instead of geotextile fabric if you have observed flooding issues in your basement or near your building foundation.



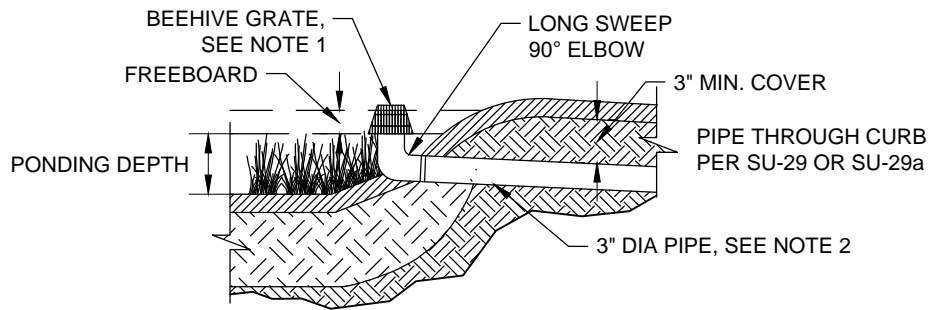

BEEHIVE OVERFLOW
NTS

LEGEND:	
	WOOD CHIP MULCH AND/OR PLANTED AREA
	RAIN GARDEN SOIL MIX
	EXISTING NATIVE SOIL

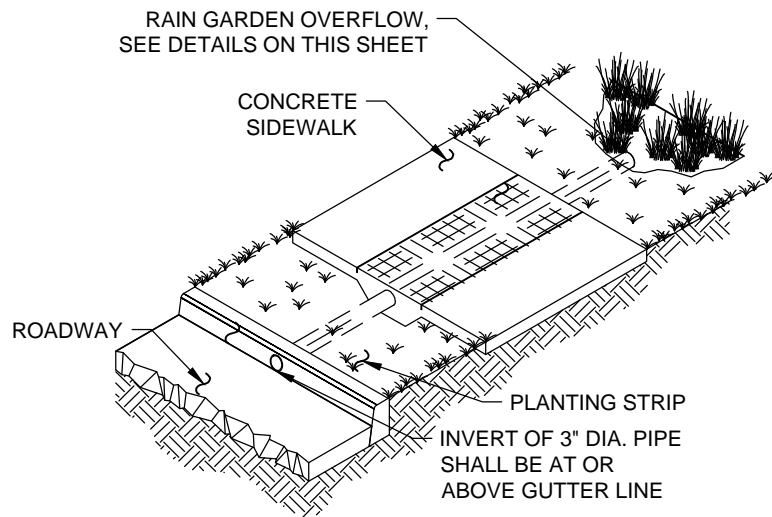

SEE STD PLAN SU-29 OR SU-29A FOR CONSTRUCTION REQUIREMENTS.

OVERFLOW PIPE THROUGH SIDEWALK TO CURB
NTS

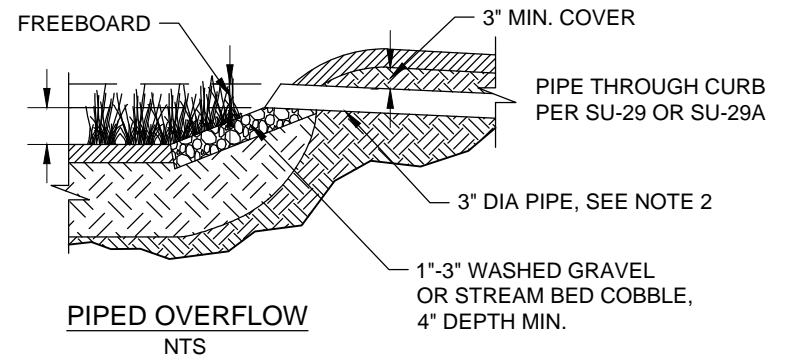

PIPED OVERFLOW
NTS



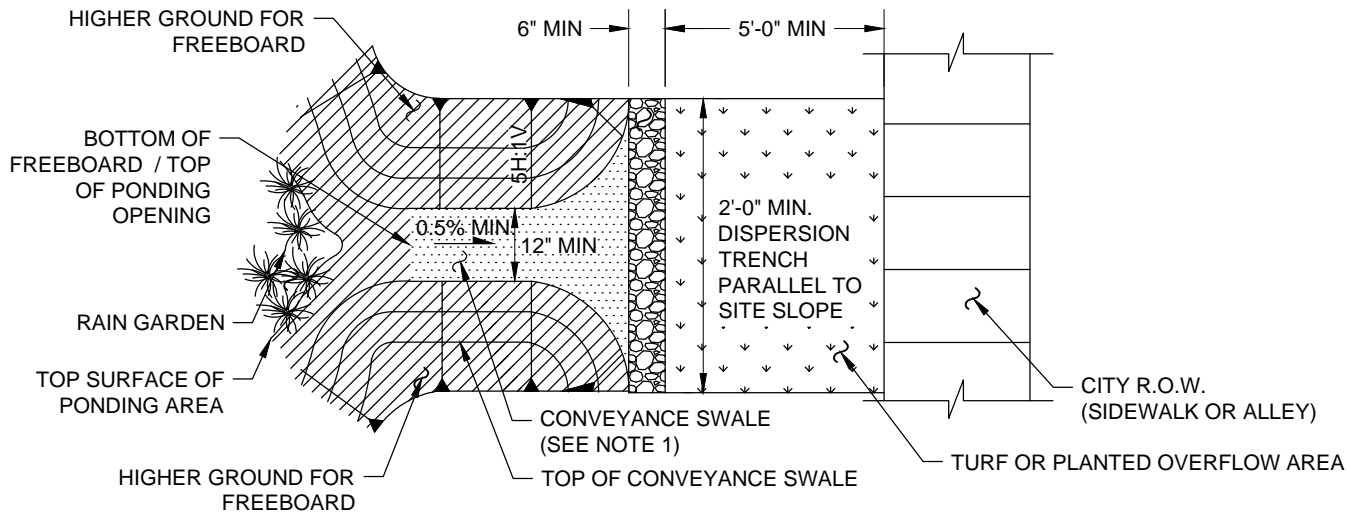

NOTES:

1. Beehive grate must be made of UV stabilized material.
2. Pipe per the City of Tacoma SWMM Volume 3 for privately maintained pipe to edge of ROW. Pipe within ROW shall be per SU-29 or SU-29a.



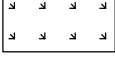

LEGEND:

-  RAIN GARDEN SOIL MIX
-  WOOD CHIP MULCH AND/OR PLANTED AREA
-  EXISTING NATIVE SOIL
-  LAWN OR PLANTED OVERFLOW AREA
-  CONVEYANCE SWALE (SEE NOTE 1)

OVERFLOW THROUGH CONVEYANCE SWALE TO R.O.W.

NTS

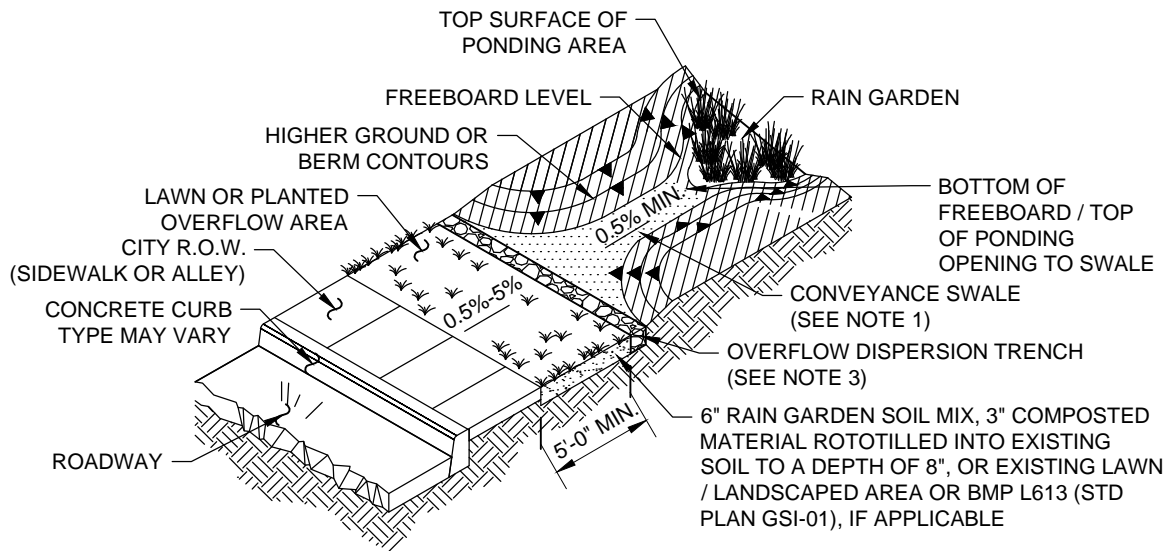

OVERFLOW THROUGH CONVEYANCE SWALE TO R.O.W.

NTS

NOTES:

1. See GSI Figure 015 for conveyance swale detail.
2. Minimum slope = 0.5%. If greater than 0.4% slope, provide erosion control options such as a rock check dam.
3. Overflow dispersion trench consists of a minimum 6" wide by 6" deep by 24" long drain rock layer lined with geotextile fabric on the sides and bottom for separation.



**CITY OF TACOMA
GREEN STORMWATER INFRASTRUCTURE
TYPICAL DETAILS**

RAIN GARDEN WITH SWALE OVERFLOW

FIGURE NO.

016

January 2016

NOTE:
 This figure applicable to driveways that are flat or slope away from the structure. Additional design considerations are required when the driveway slopes toward the structure.

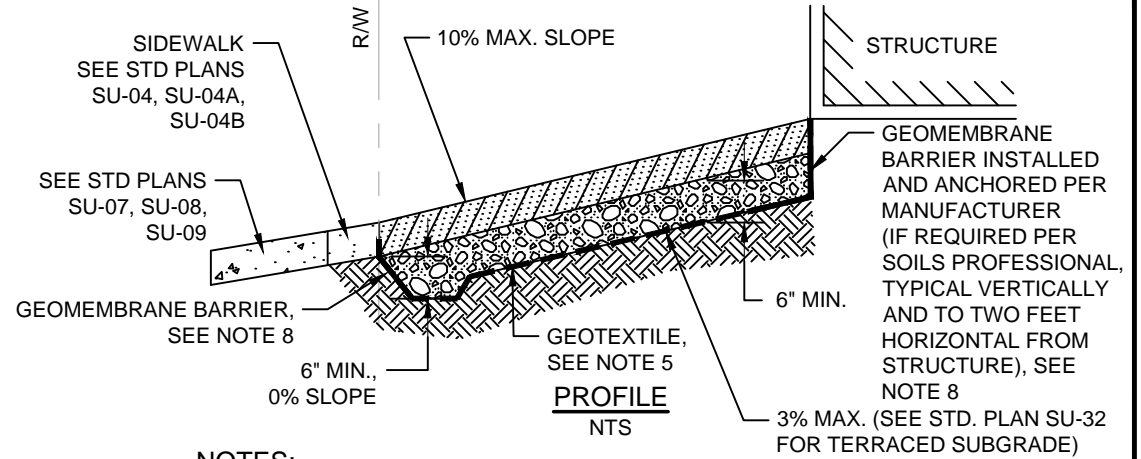
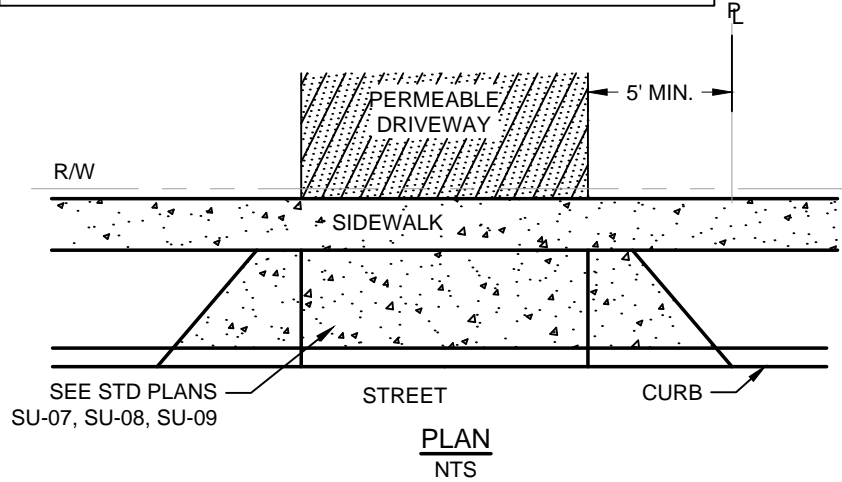

- NOTES:**
1. Permeable pavers may be allowed. Cross section shall meet manufacturer's recommendations and include an appropriate reservoir layer and scarification of subgrade per SWMM.
 2. Limit run-on to permeable pavement surfaces to the maximum extent practicable. Run-on shall only be allowed from fully stabilized areas.
 3. 6-inch minimum treatment layer of sand or media if required per SWMM.
 4. Thicker section of ballast may be required to establish sufficient reservoir capacity. Engineer to provide calculations per SWMM.
 5. Geotextile may be required between native soils and permeable pavement section, per soils professional recommendation. Geotextile will be required between permeable ballast and sand layer. Geotextile shall be geotextile for separation per WSDOT 9.33.2(1), woven, Table 3 and installed per WSDOT 2-12.3(1).
 6. Refer to SWMM BMP L633 for design criteria and soils suitability.
 7. Work within right-of-way shall be in compliance with the Right-of-Way Design Manual Chapter 4 Sections 5.4.1 for subgrade and APWA GSP 4-04.2 Gravel Base and 9-03.9(2) Permeable Ballast Opt1 and shall be installed per APWA GSP 4-04.3(5) Shaping and Compaction. It is recommended to follow Right-of-Way Design Manual and APWA GSP for work on private property.
 8. Permeable pavement surfacing shall meet APWA GSP 5-04.3 Construction Requirements Porous Asphalt (PHMA/PWMA) Acceptance Infiltration Test for porous asphalt or 5-06.3(6)A Infiltration Rate of the Placed Pavement for pervious concrete.
 9. Geomembrane barrier shall provide an impermeable barrier between standard and permeable section. It shall be installed below finished grade and per Std. Plan GSI-18. Geomembrane barrier seams shall overlap at least 18" or per manufacturer's recommendations. Geomembrane barrier shall extend the length of the permeable section when adjacent to standard pavement.

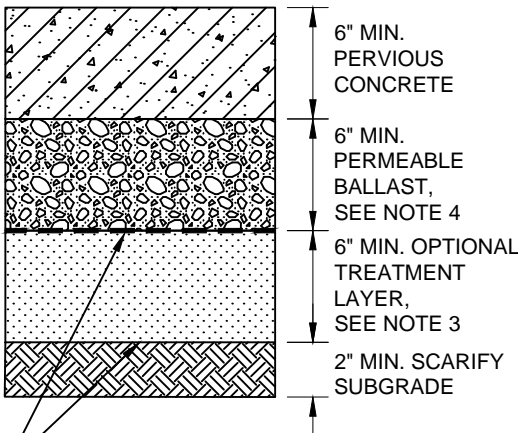

GEOTEXTILE REQUIRED BETWEEN PERMEABLE BALLAST AND SAND LAYER IF SAND LAYER UTILIZED. GEOTEXTILE MAY BE REQUIRED BETWEEN PERMEABLE BALLAST AND NATIVE SOILS, SEE NOTE 5

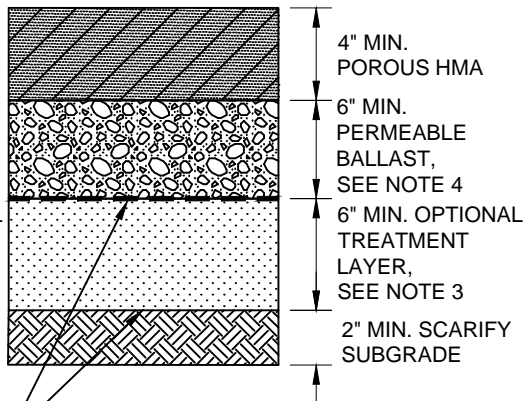

GEOTEXTILE REQUIRED BETWEEN PERMEABLE BALLAST AND SAND LAYER IF SAND LAYER UTILIZED. GEOTEXTILE MAY BE REQUIRED BETWEEN PERMEABLE BALLAST AND NATIVE SOILS, SEE NOTE 5

PERVIOUS CONCRETE SECTION
NTS

POROUS HMA SECTION
NTS



**CITY OF TACOMA
 GREEN STORMWATER INFRASTRUCTURE
 TYPICAL DETAILS**

PERMEABLE DRIVEWAY

FIGURE NO. 017

September 2016