

Exhibit 14
Cut Sheet Details

AV23 Solar Obstruction Light

Typical Applications

- Solar Obstruction Light (LIOL A)

Major Benefits

- 5.4km visible range (flashing)
- Integrated solar/battery system
- 12watt solar module
- 7.5Ah SLA battery
- ICAO Approved AV23 Solar Obstruction Light (LIOL A)
- Ultra-high intensity LEDs (no changing globes ever)

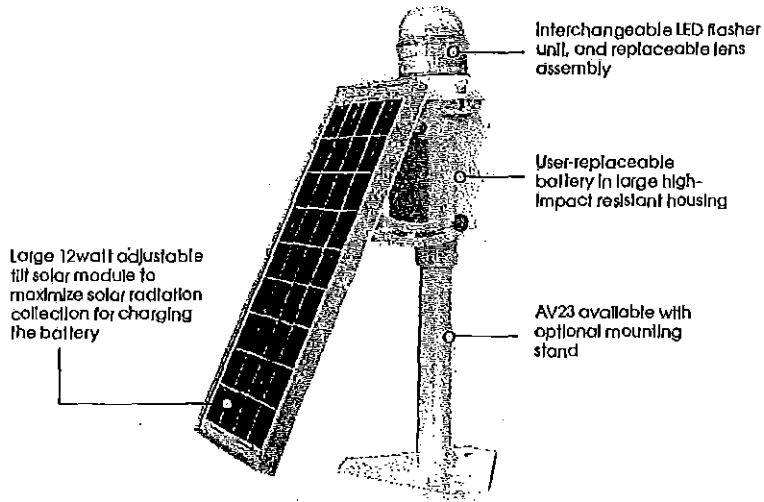

The AV23 is a low intensity solar-powered obstruction light designed to offer users years of maintenance-free operation. The unit is completely self-contained and incorporates a large 12watt solar module, 7.5Ah battery, LED light source and advanced driving circuitry.

During daylight hours the solar module will charge the battery through an advanced switch-mode regulator incorporated into the flasher unit. The lantern will automatically begin operation at dusk - once the ambient light threshold drops sufficiently.

The light is built from heavy-duty cast aluminum - subject to 7-stage powder-coating, and offers users enormous impact and weather resistance.

This completely self-contained unit with integrated solar module and battery system saves users considerably in power, cabling and on-going maintenance associated with traditional incandescent systems.

The AV23 has been independently tested to be in accordance with the requirements of the photometric and colourmetric specifications for a Low Intensity Type A Obstacle Light listed in table 6-3 of ICAO Annex 14 Volume 1, 'Aerodrome Design and Operations', Fourth Edition July 2004.

With minimal access for maintenance, stadium operators in Cyprus now enjoy hassle-free operation of AV23 units, installed as solar obstruction lights.

Sports Stadium Installations, Cyprus

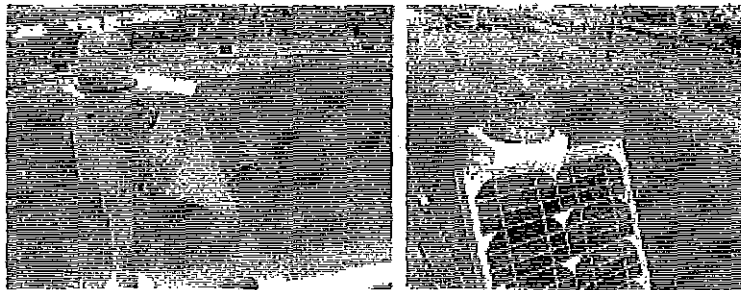

This equipment meets the requirements of a Low Intensity Type A Obstruction Light, ICAO Annex 14 volume 1, "Aerodrome Design and Operations", Fourth Edition July 2004.



AVLITE SYSTEMS
11 Industrial Drive
Somerville Victoria 3912 Australia
Ph: +61 (0)3 6977 6128 Fax: +61 (0)3 6977 6124
Web: www.avlite.com Email: info@avlite.com



Exhibit 10 - Cut sheet details
San Rafael Airport Project



Typical Light-Structure Green™ System Detail - 3 Luminaires

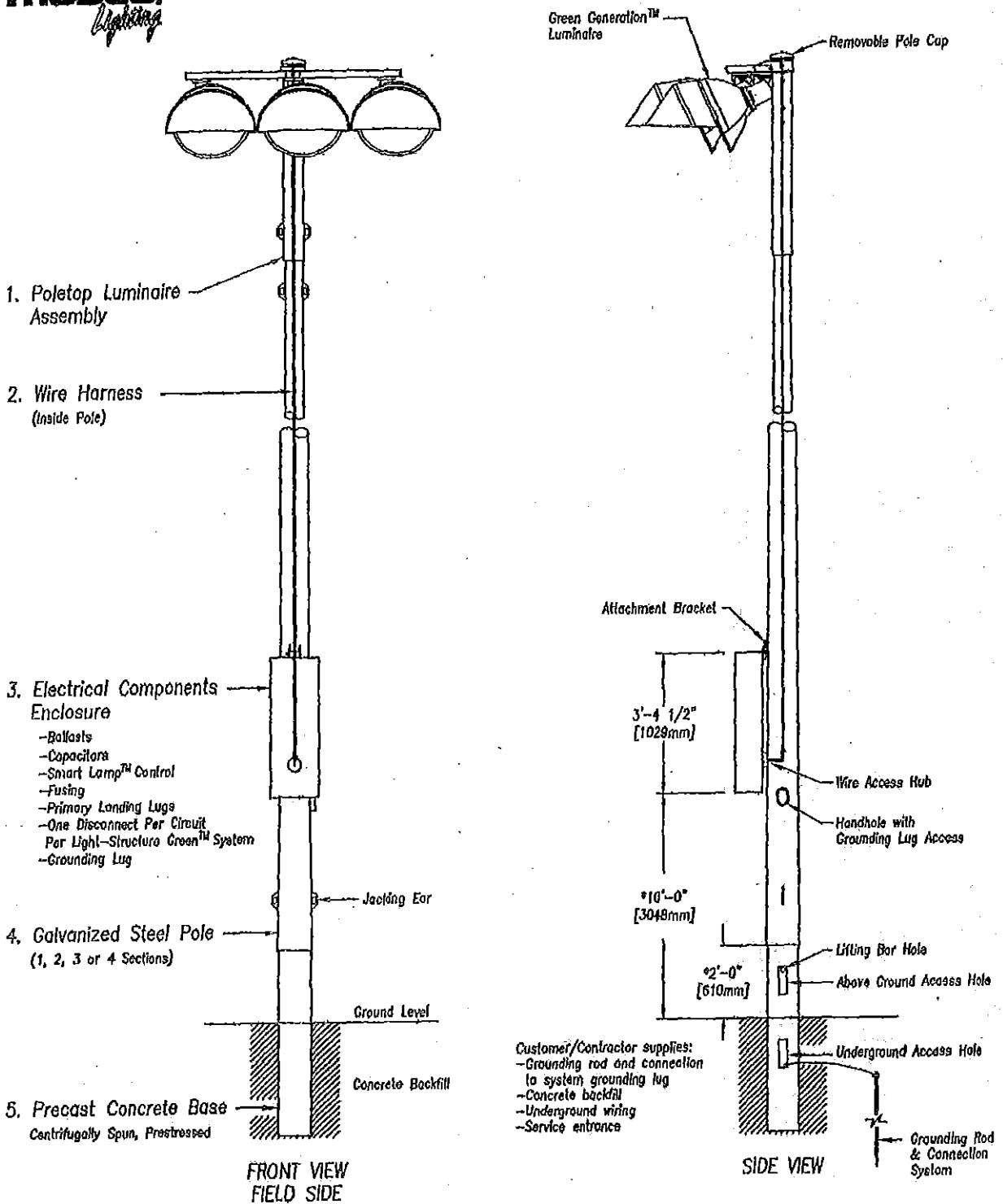

Notes:

1. This drawing is not to scale.
2. * This dimension for reference only. Variances may occur depending on steel pole tolerances, concrete tolerances, galvanizing thickness, hole depth accuracy.
3. Musco provides a base installation bar, on installation level modified for taper, and installation wedges.
4. Provisions for auxiliary equipment such as speaker or security lighting can be incorporated.
5. Copyright 1991, 2005 Musco Lighting. Patents issued and pending.

LSG-03



Typical Light-Structure Green™ System Detail - 2 Luminaires

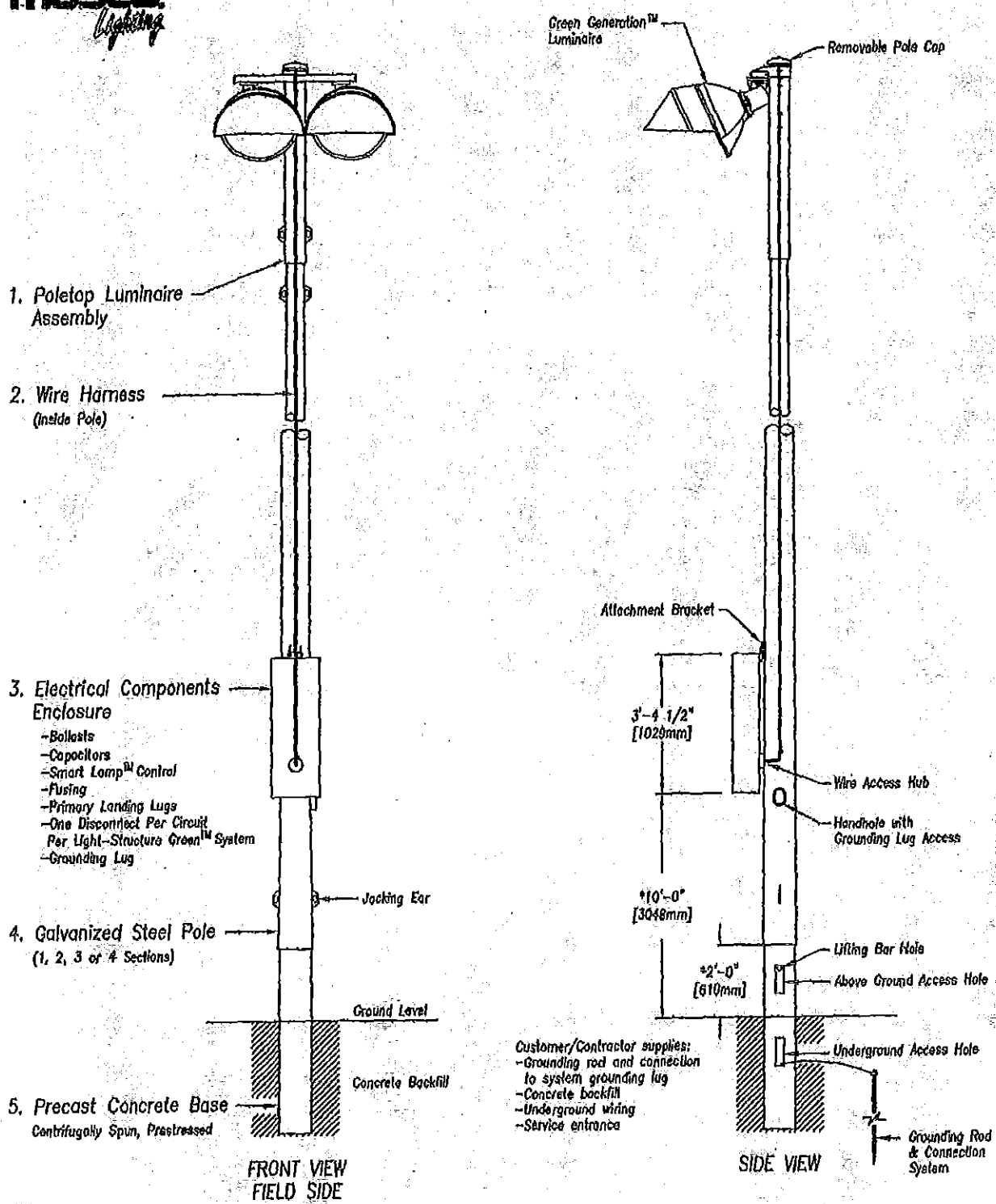

- Notes:
1. This drawing is not to scale.
 2. * This dimension for reference only. Variances may occur depending on steel pole tolerances, concrete tolerances, galvanizing thickness, hole depth accuracy.
 3. Musco provides a base installation bar, an installation level modified for taper, and installation wedges.
 4. Provisions for auxiliary equipment such as speaker or security lighting can be incorporated.
 5. Copyright 1991, 2005 Musco Lighting. Patents issued and pending.

LSG-02

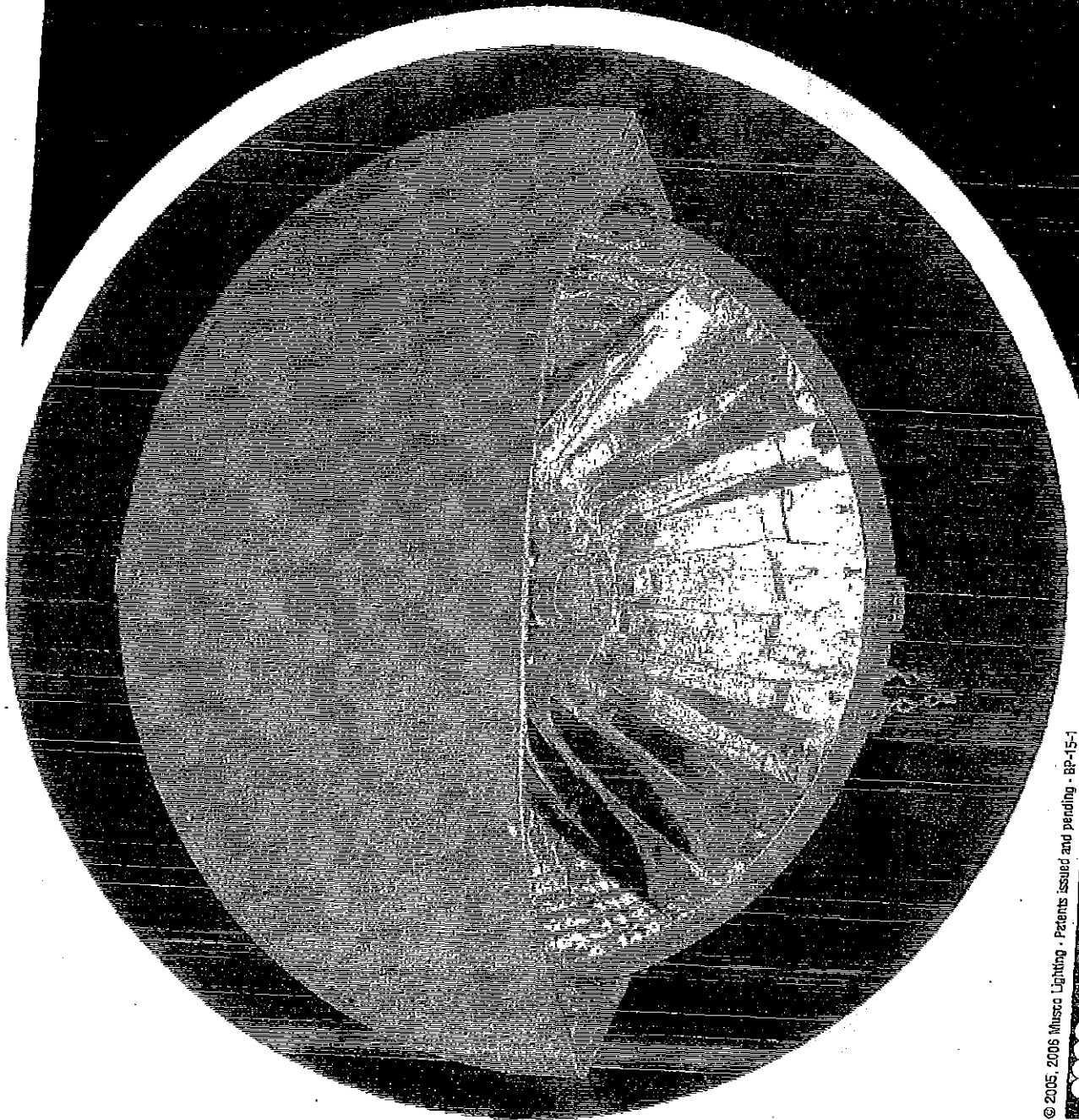

© 2005, 2006 Musco Lighting. Patents issued and pending. BP-15-1



Light Structure
BP-15-1

FEATURES

The Designer Canopy Luminaire can bring exquisite style to otherwise ordinary spaces. Moreover the low brightness illumination will help to create a safer and more secure environment.

Three Low Brightness Distributions

All (3) optical systems feature deeply recessed lamp positioning to provide sharp visual cutoff to the lamp and lamp images at normal viewing angles.

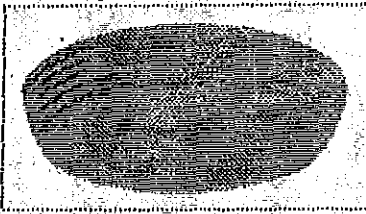

The fresnel lens provides an even, symmetrical downlight distribution. This is an ideal distribution for theatre entrances, lobbies and other covered wide area lighting applications.

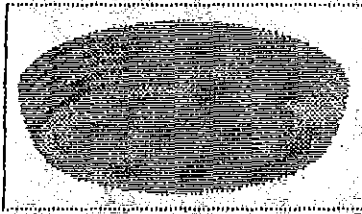

The prismatic downlight lens creates an elongated lighting pattern that uniformly illuminates covered pathways and walkways adjacent to buildings.

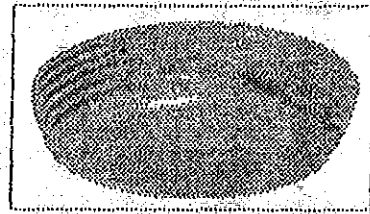

The prismatic lens wall washer optical system uniformly illuminates adjacent vertical surfaces - free of streaks and striations. The downlight component concurrently provides high light levels on the pathway below.

High Performance Lamps

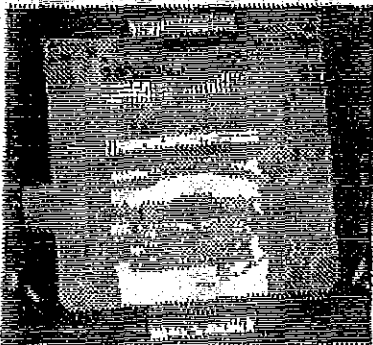

HID is the preferred outdoor lighting source for long lamp life, energy efficiency and low temperature starting. The Designer Canopy Luminaire utilizes High Intensity Discharge lamps up to 160W HPS and 176W MH.

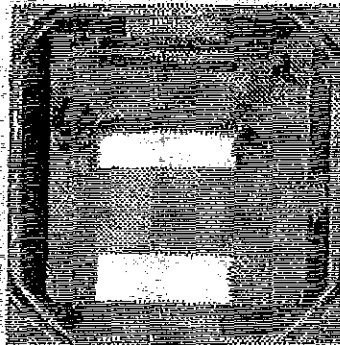

Where instant starting and a less intense source of illumination is desired, the Designer Canopy Luminaire is also available for use with the popular 42W compact fluorescent lamp.

Rugged Fixture Construction

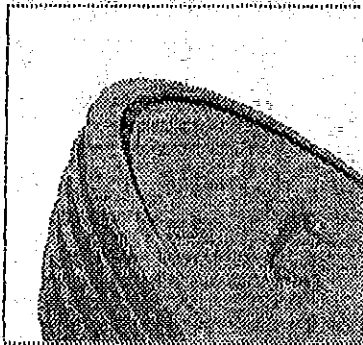

Hollow core silicone gaskets exclude insects, moisture, dust, and pollutants from luminaire. Rugged die cast trim and tempered glass lenses deter casual vandalism. Tamper resistant hardware is optional. Polyester powdercoat finishes are fade and abrasion resistant.

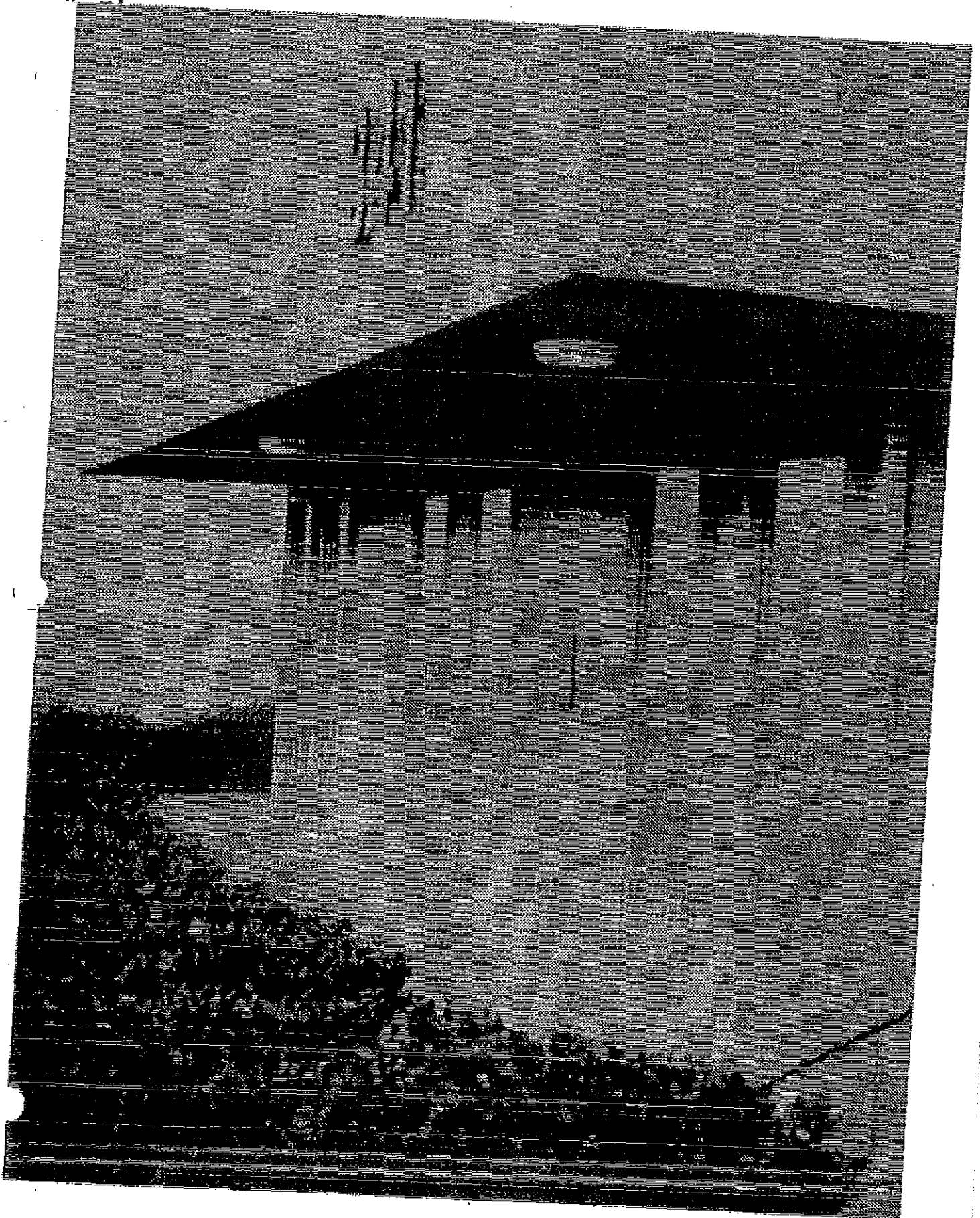

Notes:

Job:

Type:

DESIGNER CANOPY

220/221 SERIES RECESSED LUMINAIRES

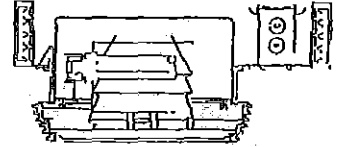

GENERAL DESCRIPTION: The Gardco Designer Canopy Luminaire is a family of downlight and wall wash ceiling mounted fixtures utilizing high intensity discharge and compact fluorescent lamps. The contemporary form housing is available in a variety of architectural finishes assuring compatibility with the building. Downlight optical systems are offered with prismatic or fresnel lenses and the wall washer is offered with a prismatic lens. The Designer Canopy Luminaire is suitable for outdoor applications and features rugged die cast construction, silicone seals and gaskets, and polyester powdercoat finishes.

ORDERING

PREFIX	DISTRIBUTION	WATTAGE	VOLTAGE	FINISH	OPTIONS

Enter the order code into the appropriate box above. Note: Gardco reserves the right to refuse a configuration. Not all combinations and configurations are valid. Refer to notes below for exclusions and limitations. For questions or concerns, please consult the factory.

PREFIX

220 Downlight
221 Wall Wash

DISTRIBUTION

P Prismatic Lens
F Fresnel Lens Available with 220 units only

WATTAGE

50MH	50CMHE ¹	50HPS	26QF ²
70MH	70CMHE ¹	70HPS	32TRF ³
100MH	100CMHE ¹	100HPS	42TRF ³
150MH ¹	150CMHE ¹	150HPS ²	
175MH			

VOLTAGE

120
277
347

Consult factory for 347V availability prior to ordering.
Not available in Ceramic Metal Halide with Electronic Ballast (CMHE) types

MH Metal Halide
CMHE Ceramic Metal Halide
HPS High Pressure Sodium
QF Quads Tube Compact Fluorescent
TRF Triads Tube Compact Fluorescent

1. ANSI E1102
2. ANSI A555

3. 250V, 32TRF and 42TRF types feature an electronic fluorescent ballast that accepts 120V through 277V, 50Hz or 60Hz input and provides for a 0°F starting temperature.

4. Ceramic Metal Halide with electronic ballast, with ballast brand selected by Gardco only, 120V or 277V only.

FINISH

BRP Bronze Paint
BLP Black Paint
WP White Paint
NP Natural Aluminum Paint
BGP Belge Paint
QC Optional Color Paint
Specify RAL designation
and CC-RAL7024
SC Special Color Paint
Specify: Must supply color chip

OPTIONS

F Fusing Not available w/ 347V or Ceramic Metal Halide with Electronic Ballast (CMHE) types
RS Tamper Resistant Hardware
QS Quartz Standby Limited to 100W maximum quartz lamp wattage
Not available in Ceramic Metal Halide with Electronic Ballast (CMHE) types
Available with 150 watt and lower only.
QST Quartz Restrike Timed Delay
Limited to 100W maximum quartz lamp wattage. Not available in Ceramic Metal Halide with Electronic Ballast (CMHE) types

Gardco Lighting reserves the right to change materials or modify the design of its product without notification as part of the company's continuing product improvement program.

© Copyright Gardco Lighting 2001-2005. All Rights Reserved. International Copyright Secured.

A Genlyte Company

Gardco Lighting
2681 Alvarado Street
San Leandro, CA 94577

800/227-0758
510/367-6900 in California
Fax: 510/357-3088
www.slelighting.com



LIGHTING
79116-92/405

CC Exhibit 14

FORM 10 SQUARE

BE/WE/BH/WH/BHT/WHT WALL MOUNT

SPECIFICATIONS

GENERAL: Each Gardco Square Form Ten wall mount is a sharp cutoff luminaire for high intensity discharge lamps. Direct mount (WE and WH) and arm mounted (BE and BH) styles are offered. Internal components are totally enclosed, rain-tight, dust-tight and corrosion resistant. No venting of optical system or electrical components is required or permitted. Luminaires are completely assembled with no disassembly required for installation. Lamping requires no lifting or hinging the luminaire housing, disturbing wiring or exposing uninsulated live parts.

HOUSING: Extruded housings (WE and BE styles) are composed of precisely mitered anodized aluminum extrusions. Fabricated (WH and BH styles) units are one piece, multi-formed aluminum with an integral reinforcing spline and a single concealed joint. All units feature a press formed aluminum top which is welded to the housing sides. Pressure injected silicone provides a continuous weatherlight seal at all miters and points of material transition.

WALL BRACKETS: All models include hooking die cast aluminum wall bracket that conceals 10 gauge mounting plate. BE and BH series include extruded arm to extend unit from wall.

LENS: Mitered, extruded anodized aluminum door frame retains the optically clear, heat and impact resistant tempered flat glass in a sealed manner using hollow section, high compliance, memory retentive extruded silicone rubber. Concealed stainless steel latch and hinge permit easy toolless access to the luminaire.

OPTICAL SYSTEMS: The segmented Form Ten optical system is homogeneous sheet aluminum, electrochemically brightened, anodized and sealed. The segmented reflectors are set in faceted arc tube image duplicator patterns to achieve IES Types I (1), III (3, FC3V), and IV (FM) distributions. The mogul base lampholder is glazed porcelain with a nickel plated screw shell with lamp grip-all securely attached to the reflector assembly. 100 MH units have medium base lampholder. All Metal Halide units in the 19" housings have lamp stabilizers ensuring precise arc tube positioning.

ELECTRICAL: Each high power factor ballast is the separate component type, capable of providing reliable lamp starting down to -20° F. The ballast is mounted on a utilized tray and secured within the luminaire, above the reflector system. Component-to-component wiring within the luminaire will carry no more than 80% of rated current and is listed by UL for use at 600 VAC at 150°C or higher. Plug disconnects are listed by UL for use at 600 VAC, 15A or higher.

FINISH: Extruded housings (WE and BE styles) are standard with natural, bronze, or black Aluminum Association Architectural Class I anodized finish applied after fabrication. Special color polyurethane finishes are available.

Formed housings (WH and BH styles) are standard with a chromate acid pretreatment and an epoxy undercoat. The finish coat is a thermosetting polyester baked at 450° F to achieve an H-2H hardness measure.

LABELS: All fixtures bear UL or CUL (where applicable) Wet Location labels.

DIMENSIONS

BE/BH/BHT

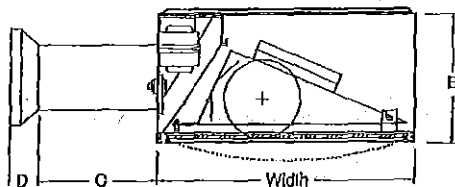

Size	Width	B	C	D
14	14"	7"	6"	2"
	35.60 cm	17.78 cm	15.24 cm	5.08 cm
19	19"	10"	9"	2"
	48.26 cm	25.40 cm	22.86 cm	5.08 cm
T19	19"	12"	9"	2"
	48.26 cm	30.48 cm	22.86 cm	5.08 cm

WE/WH/WHT

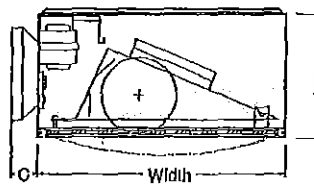

Size	Width	B	C
14	14"	7"	2"
	35.65 cm	17.78 cm	5.08 cm
19	19"	10"	2"
	48.26 cm	25.40 cm	5.08 cm
T19	19"	12"	2"
	48.26 cm	30.48 cm	5.08 cm

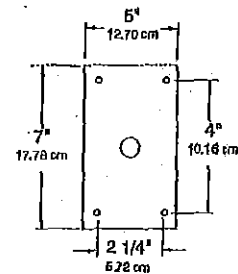

Wall Mounting Dimensions

Gardco Lighting reserves the right to change materials or modify the design of its product without notification as part of the company's continuing product improvement program.

© Copyright Gardco Lighting 2001-2005. All Rights Reserved. International Copyright Secured.

A Genlyte Company

Gardco Lighting
2661 Alvarado Street
San Leandro, CA 94577

800/227-0750
510/357-6900 In California
Fax: 510/357-3089
www.sitelighting.com



79115-44/0205

BOLLARD

BS700/BR800

SPECIFICATIONS

GENERAL DESCRIPTION: Each Gardco BS700 and BR800 is a bollard luminaire utilizing 35W through 100W high intensity discharge lamps. Luminaires feature a precision anodized aluminum reflector system which provides low glare uniform illumination and wide spacings. Units are totally sealed and gasketed preventing intrusion of moisture, dust and insects into the optical or electrical chambers.

HOUSING: Top and bottom housings are .125" (round) or .156" (square) high strength 6063-T5 extruded aluminum. Bottom section has a welded-in cast ring for attachment to base assembly with four (4) hex head set screws.

LENS: The lens is .250" (round) or .312" (square) clear virgin acrylic positioned between upper and lower housing sections. Silicone gasket completely seals unit and permits thermal expansion.

OPTICAL SYSTEM: Electrochemically anodized deformed aluminum reflector provides efficient illumination and brightness control. Hammer-toning of reflector assures clean, unstratified beam pattern.

SOCKET: Medium base pulse rated lampholder is glazed porcelain with nickel plated reinforced screw shell and spring loaded contact.

ANCHORAGE: Base assembly consists of a cast aluminum platform and ballast mounting bracket. Assembly is secured and leveled to the mounting foundation with four (4) 3/8" X 8" X 1 1/2" anchor bolts on a 4 3/4" bolt circle. Ballast is prewired with quick electrical disconnects and mounting bracket is secured with two (2) Phillips head screws for ease of installation and servicing.

ELECTRICAL: Each high power factor ballast is the separate component type, capable of providing reliable lamp starting down to -20° F. Component-to-component wiring within the luminaire will carry no more than 80% of rated current and is listed by UL for use at 600 VAC at 150°C or higher. Plug disconnects are listed by UL for use at 600 VAC, 15A or higher.

FINISH: Each luminaire receives a fade and abrasion resistant electrostatically applied, thermally cured and textured polyester powdercoat finish.

LABELS: All fixtures bear UL or CUL (where applicable) Wet Location labels.

DIMENSIONS

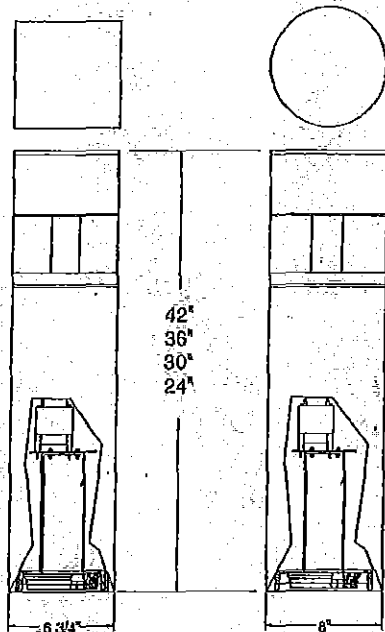

NOTE: Factory supplied template must be used when setting anchor bolts. Gardco Lighting will not honor any claim for incorrect anchorage placement from failure to use factory supplied templates.

Stub-up Projection 3" Max.
Bolt Projection 1 1/2" + 1/4"

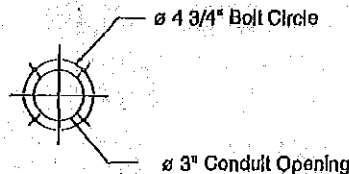
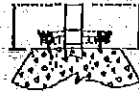

Gardco Lighting reserves the right to change materials or modify the design of its product without notification as part of the company's continuing product improvement program.

© Copyright Gardco Lighting 2001-2004. All Rights Reserved. International Copyright Secured.

A Genlyte Company

Gardco Lighting
2661 Alvarado Street
San Leandro, CA 94577

800/227-0768
510/357-8900 in California
Fax: 510/357-3088
www.sitelighting.com



79115-330604

CC Exhibit 14

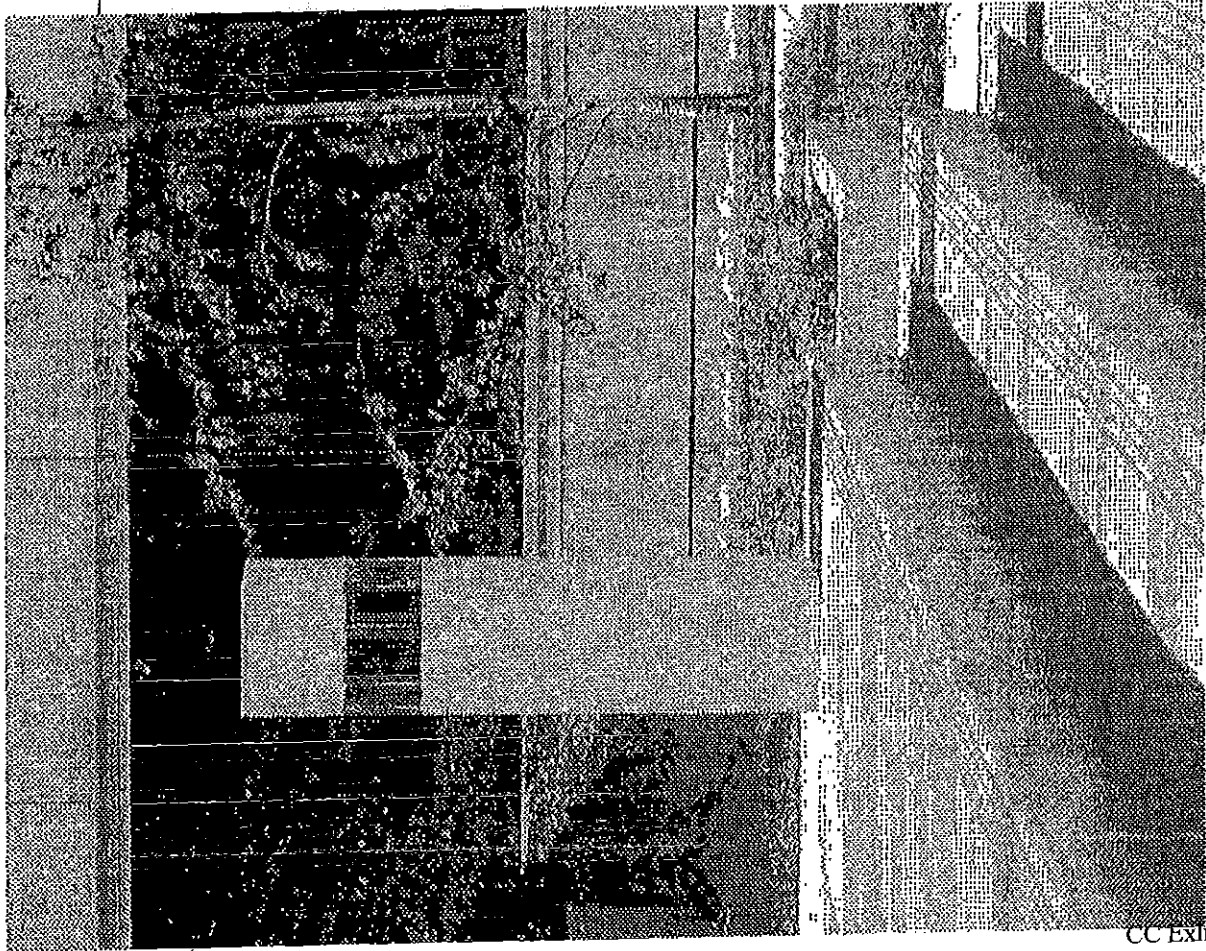

ES-BOARDS, INC. BOLLARD

GENERAL DESCRIPTION: Carlon's family of 18" diameter round and 6 3/4" square bollards provides uniform illumination, wide spacing and remarkable brightness control. Rugged extruded and cast construction with seals and gaskets ensures years of trouble-free service.

ORDERING

PREFIX	HEIGHT	WATTAGE	VOLTAGE	FINISH	OPTIONS
ES-700	42"	500W	220	GRP	F
ES-300	36"	300W	208	SLP	SBD
	30"	700W	240	NP	DUP*
	24"	1000W	Z77	WF	GLY*

FINISH & QUALITY:

- GRP: Granite Finish
- SLP: Slate Finish
- NP: Natural Aluminum Finish
- WF: White Finish
- CC: Clear Coat
- SC: Special Clear Coat (See Color Selection Guide)

OPTIONS:

- F: Fluorescent Tube (See Color Selection Guide)
- SBD: Solid Back Diffuser
- DUP*: Double Diffuser
- GLY*: Glycol Glass (See Color Selection Guide)

DIMENSIONS

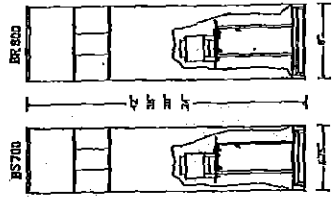
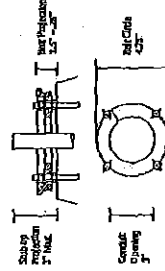
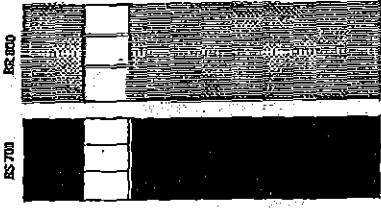

POLES 4" STRAIGHT SQUARE ALUMINUM (TENON BASE)

SPECIFICATIONS

POLE SHAFT: The pole shaft is a one-piece, 4" square, seamless 6000 series extruded aluminum tubing and is heat treated to achieve a T8 temper with a guaranteed minimum yield strength of 31 KSI. Pole wall thickness is .100".

BASE TENON ASSEMBLY: The tenon anchor base assembly consists of structural quality carbon steel tubing with a minimum 40 KSI yield strength welded to a structural steel base with a guaranteed minimum yield strength of 50 KSI. The base plate telescopes the pole shaft and is differentially welded on both top and bottom. The base is provided with slotted bolt holes to accommodate a $\pm .5$ " variation in the rotational flexibility. The entire assembly is hot-dipped galvanized. Four (4) mechanically galvanized fasteners secure the aluminum pole shaft to the base tenon assembly.

ANCHOR BOLTS: Anchor bolts are fabricated from a commercial quality hot rolled carbon steel bar that meets or exceeds a minimum guaranteed yield strength of 60,000 psi. Bolts have an "L" bend on one end and threaded on the opposite end. Anchor bolts are completely hot dipped galvanized. Four (4) properly sized bolts, each furnished with two (2) regular hex nuts, two (2) flat washers and one (1) lock washer are provided per pole, unless otherwise specified.

BASE COVER: A two-piece, fabricated aluminum cover completely conceals the entire base plate and anchorage. The base cover is secured to the base assembly with four (4) stainless steel fasteners.

HANDHOLE: The handhole has a nominal rectangular 2" X 4" inside opening in the pole shaft and tenon assembly. Included is an aluminum cover plate with attachment screws. The handhole is located 18" above the base and 180° clockwise with respect to the luminaire arm when viewed from the top of the pole for one arm. For two arms the handhole is located directly under one arm.

POLE TOP CAP: Each pole assembly is provided with a removable cast aluminum pole top cap. The pole top cap is secured with two (2) stainless steel allen head set screws.

FINISH: Poles are available with bronze, natural or black Aluminum Association Architectural Class 1 anodized finish. Electrostatically applied, thermally cured TGIC polyester powdercoat finish is also available.

DESIGN: The poles as charted are designed to withstand dead loads and predicted dynamic loads developed by variable wind speeds with an additional 30% gust factor under the following conditions:

The charted weights include luminaire(s) and/or mounting bracket(s).

The wind velocities are based on 10 mph increments from 80 mph through 100 mph. Poles to be located in areas of known abnormal conditions may require special consideration. For example: coastal areas, airports and areas of special winds.

Poles are designed for ground mounted applications. Poles mounted on structures (such as buildings and bridges) may also necessitate special consideration requiring Gardco/Emco Lighting's recommendation.

Height correction factors and drag coefficients are applied to the entire structure. An appropriate safety factor is maintained based on the minimum yield strength of the material incorporated in the pole.

WARNING: This design information is intended as a general guideline only. The customer is solely responsible for proper selection of pole, luminaire, accessory and foundation under the given site conditions and intended usage. The addition of any items to the pole, in addition to the luminaire, will dramatically impact the EPA load on that pole. It is strongly recommended that a qualified professional be consulted to analyze the loads given the user's specific needs to ensure proper selection of the pole, luminaire, accessories, and foundation. Gardco/Emco Lighting and Genlyte assume no responsibility for such proper analysis or product selections. Failure to insure proper site analysis, pole selection, loads and installation can result in pole failure, leading to serious injury or property damage.

GENERAL INFORMATION: Mounting height is the vertical distance from the base of the lighting pole to the center of the luminaire arm at the point of luminaire attachment.

Twin arms as charted are oriented at 180° with respect to each other. For applications of two (2) arms at 90° or other multiple arm applications, consult the factory.

DIMENSIONS

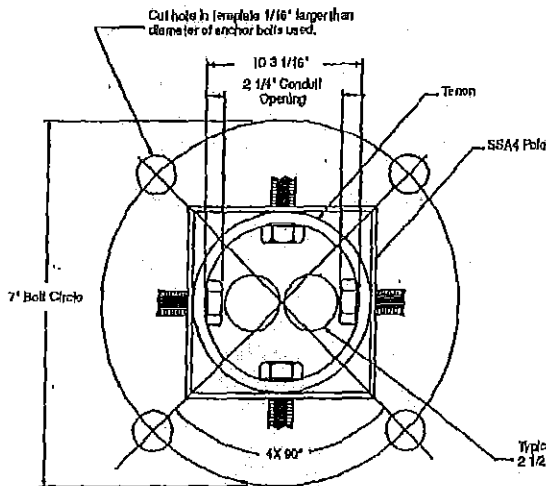

NOTE: Internal clearance of tenon/pole mounting bolts dictates allowable area for stub-ups.

NOTE: Factory supplied template must be used when setting anchor bolts. Gardco Lighting will not honor any claim for incorrect anchorage placement from failure to use factory supplied templates.

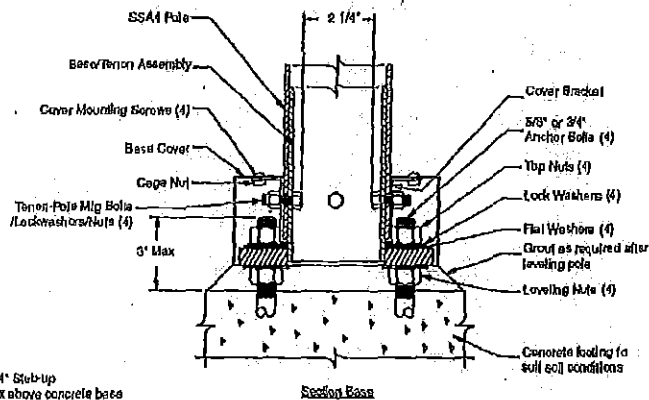

Gardco Lighting/EMCO Lighting reserves the right to change materials or modify the design of its product without notification as part of the company's continuing product improvement program.

© Copyright Gardco Lighting 2001-2004. All Rights Reserved. International Copyright Secured.

A Genlyte Company

2661 Alvarado Street
San Leandro, CA 94577
800/227-0768
610/357-6900 In California
Fax: 610/357-3088
www.siteighting.com



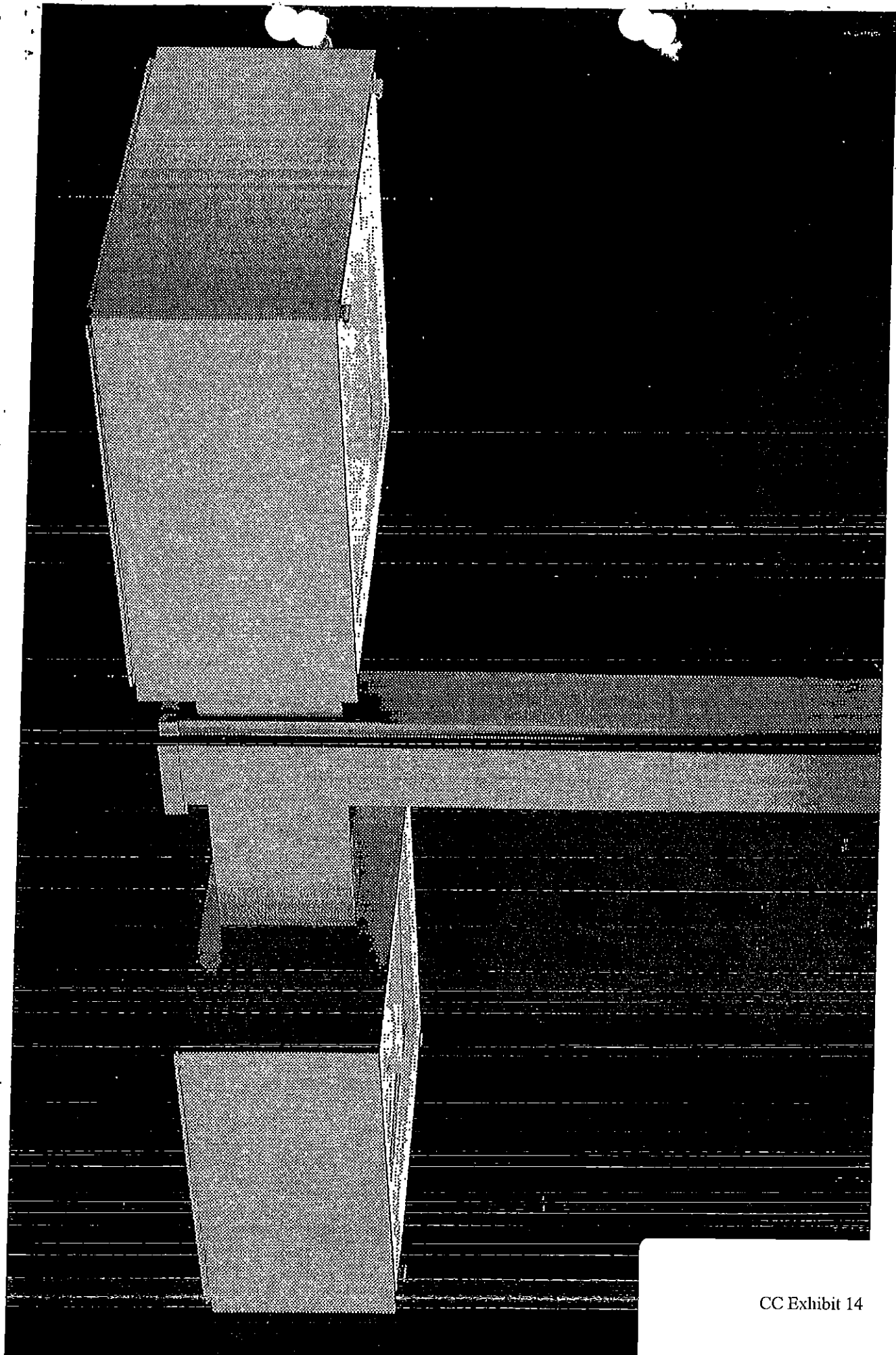

LOOK LIKE GRASS...FEELS LIKE GRASS...PLAYS LIKE GRASS.®

FIELDturf[®].com

PRODUCT DATA - OUTDOOR SOCCER US

Product Name: FieldTurf Pro Series Outdoor Monofilament (FTOM 1S)

Property		Units	ASTM
Pile Yarn Type:	UV-resistant polyethylene		
Yarn Linear Density:	9000	Denier +/- 5%	D1907
Yarn Breaking Strength	24 nominal	lbs	D2256
Yarn Maximum Elongation	40% nominal		D2256
Pile Height	2.25-2.5	inches	D5848
Pile Weight	36	oz/yd ²	D5848
Total Weight	61	oz/yd	D5848
Primary Backing Weight	>7	oz/yd ²	D5848
Secondary Backing Weight	16-18	oz/yd ²	D5848
Stitch Gauge	3/4 inch centers		D5848
Tuft withdrawal force	>6	lbs/force	D1335
Grab Tear Length	>200	lbs/force	D5034
Grab Tear Width	>200	lbs/force	D5034
Pill Burn Test	Pass		D2859
Impact Attenuation	<200	G-max	F1936
Permeability	>40	inch/hour	DIN 18-035
Total Depth of Infill Material	1.75	inches	n/a
Manufactured Rolls			
Width (Useable)	15 feet		
Length	Up to 330 feet		
Shipping Weight (linear foot)	6.4 lbs		
Line Colours	Yellow, White		
Line Widths	Up to 6 feet		
Roll Diameters	Up to 4.5 feet		
Seams	Sewn		

FieldTurf has the right to modify technical specifications on the above-mentioned product. Delivered products can slightly differ from the technical data. FieldTurf guarantees the technical quality of the proposed article.

Modified: Aug. 11, 2005

FieldTurf USA Inc.
5211 Mitchell Bridge Road, Dalton, GA, L
Toll Free: (800) 724-2969, (514) 340-9311, Fax

CC Exhibit 14

Typical Edging Detail - Standard Curb

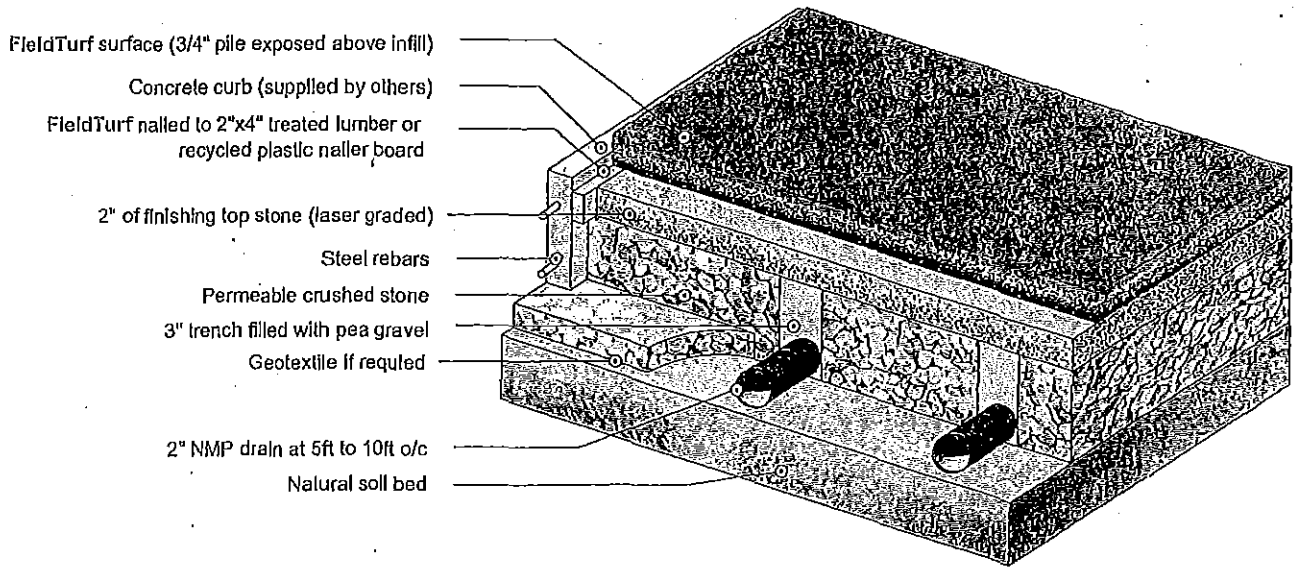

Edging Detail - Concrete Curb

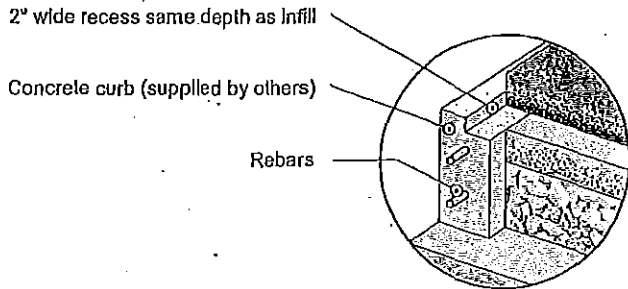

Edging Detail - Recycled Plastic Curb

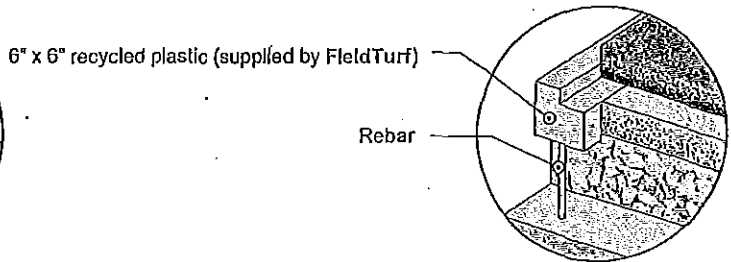

Typical Base Cross-Section

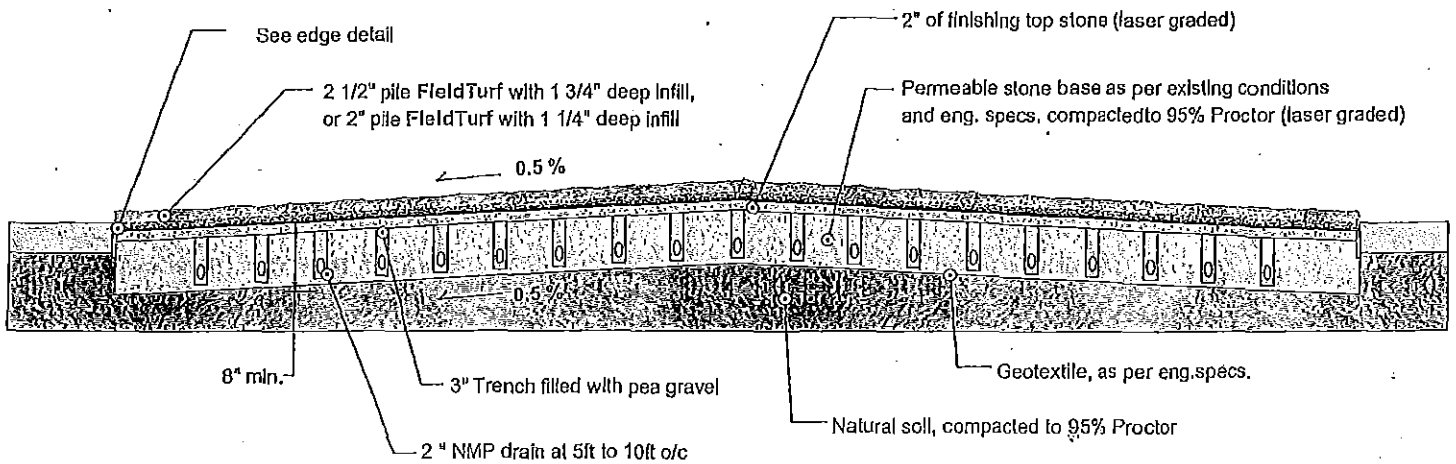

NOT TO SCALE



FIELDTurf
www.fieldturf.com

CRUSHED STONE BASE WITH 2" PIPES (NMF)

CC Exhibit 14



A GANNETT COMPANY

Vehicular Steel Truss Bridges



Crossing the nation with bridges you can depend on

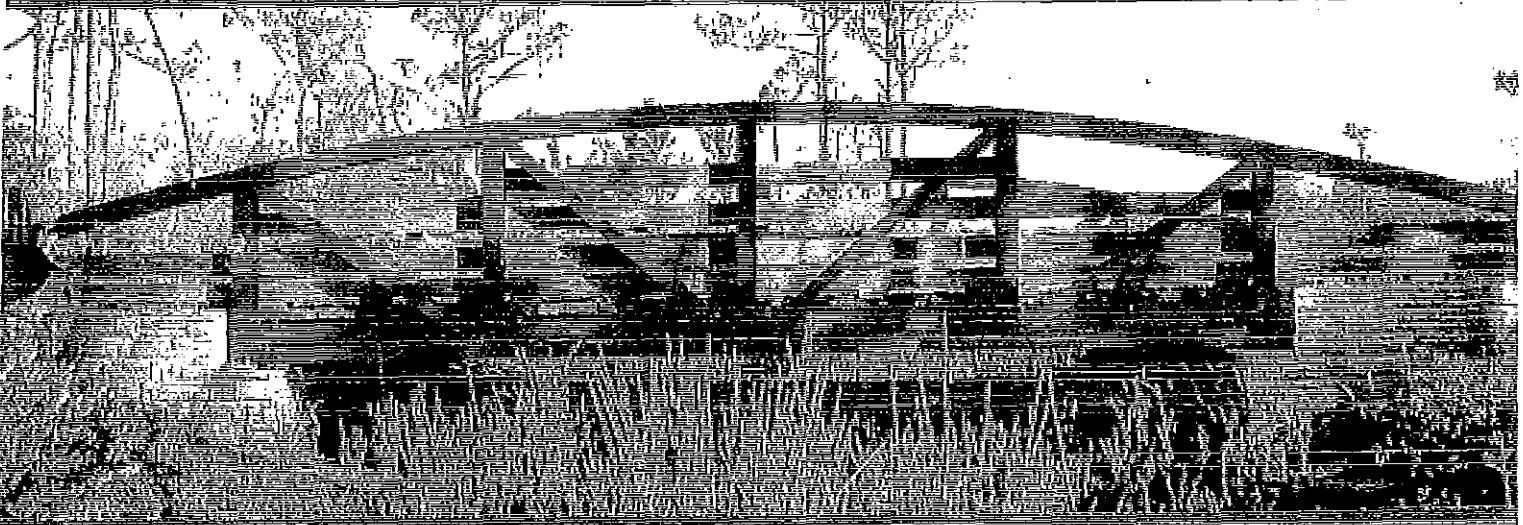

Environmentally friendly

Aesthetically pleasing



RECEIVED

OCT 19 2005

STEADFAST BRIDGES
GANNETT

Exhibit 15

**CITY OF SAN RAFAEL
NOTICE OF PUBLIC HEARING**

You are invited to attend the City Council hearing on the following project:

PROJECT: The City Council will consider: a) Certification of the San Rafael Airport Recreational Facility Final Environmental Impact Report (FEIR) (SCH: 2006-012-125); b) Ordinance Rezoning from Planned Development - Wetland Overlay (PD1764-WO) District to revised PD District; c) Master Use Permit amendment; and d) Environmental and Design Review Permit to permit construction of a private indoor and outdoor recreational facility on a portion of the 119.52-acre San Rafael Airport property, including an 85,700-square-foot recreational building, lighted outdoor sports fields, and associated parking, landscaping, lighting, fencing and access roadway improvements. The City of San Rafael Planning Commission reviewed and recommended approval of the project entitlements and rezoning on June 6, 2012. Address: 397-400 Smith Ranch Rd. (APN: 155-230-10 thru 16). Applicant: San Rafael Airport LLC; Robert Herbst. Zone District: PD1764-WO. File No.: ZC05-01/UP05-08/ED05-15.

As required by state law, the project's potential environmental impacts have been assessed. At its January 24, 2012 meeting the Planning Commission recommended certification of an EIR for the project that meets the provisions of the California Environmental Quality Act (CEQA). The City Council will consider Certification of the EIR, adoption of findings of fact and a Mitigation Measuring and Reporting Program (MMRP) required for approval of the project pursuant to CEQA Guidelines.

HEARING DATE: Monday, December 3, 2012 at 6:00 P.M. (note: early start time)

LOCATION: San Rafael City Hall – City Council Chambers
1400 Fifth Avenue at "D" Street
San Rafael, California

WHAT WILL HAPPEN: You can comment on the project. The City Council will consider all public testimony and decide whether to approve the project applications.

IF YOU CANNOT ATTEND: You can send a letter to the Community Development Department, Planning Division, City of San Rafael, P.O. Box 151560, San Rafael, CA 94915-1560. You can also hand deliver it prior to the meeting.

FOR MORE INFORMATION: Contact Kraig Tambornini, Project Planner at (415) 485-3092 or kraig.tambornini@cityofsanrafael.org. You can also come to the Planning Division office, located in City Hall, 1400 Fifth Avenue, to look at the file for the proposed project. The office is open from 8:30 a.m. to 5:00 p.m. on Monday and Thursday and 8:30 a.m. to 12:45 p.m. on Tuesday, Wednesday and Friday. You can also view the staff report after 5:00 p.m. on the Friday before the meeting at <http://www.cityofsanrafael.org/meetings>

SAN RAFAEL CITY COUNCIL

Esther Beirne
CITY CLERK, City of San Rafael

By Jeanne M. Leoncini
Deputy City Clerk

Exhibit 16

Public Comments

JANE CHANG
23 Wharf Circle
San Rafael, CA 94903

May 26, 2012

City of San Rafael, Community Development
P. O. Box 151560
San Rafael, CA 94915-1560

ATTENTION: Kraig Tambornini, Senior Planner

TO HONORABLE PLANNING COMMISSION:

I have been a homeowner in Captain's Cove, San Rafael, since 1994. I submitted my review comments of DEIR and EIR relating to rezoning from Planned Development-Wetland Overlay (PD1764-WO) District to a revised PD to permit a new private indoor and outdoor recreational facility on a portion of the 119.52-acre San Francisco Airport property. I urge you to disapprove the San Rafael Airport Recreational Facility project considering the merits of the following:

1. The proposed land use is incompatible with the surrounding existing developments - It is surrounded by a single-family residential neighborhood which is not a typical location for such a facility, and in particular one with hours of operation ending at midnight. In order to avoid disturbance of the residents in the surrounding neighborhood by higher traffic volume and noise generated by the facilities, these facilities are usually located in either the light industrial or office/warehouse neighborhoods.
2. The site is not suitable for the proposed land use because many environmental concerns were not properly addressed and fully mitigated - jeopardizing the existing critical habitat for the endangered species; and protecting wetlands and proper levee maintenance.
3. Structure integrity and safety concerns - It is questionable whether the proposed metal building in the Flood Zone AE would have the ability to withstand flooding. In addition, the building and parking lots are located in close proximity to an existing active airport.

Your prompt attention to this matter is greatly appreciated.

Sincerely,

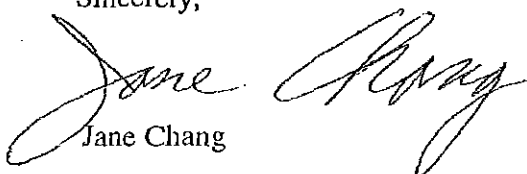
Jane Chang



Central Marin Soccer Club

May 29, 2012

Re: Support for the San Rafael Sports Center

City of San Rafael, Planning Commissioners,

My name is Rick Williams and I am President of Central Marin Youth Soccer, which represents 450 current and thousands of past families, who have had children come through our program. At last, after a long 6-7 years of dreaming about all having all weather fields, we are finally here to discuss the benefits of this intensely needed project for our community. With all the meetings and testimony on this project, I am confident there is no debate regarding the need for this facility in our community.

I want to share with you the efforts our families go through to keep their kids active, healthy, engaged and thriving. Without all weather fields in San Rafael, our families travel hundreds of mile per month, thousands of miles per year to drive to other communities who have built these greatly needed facilities for their community. Why do we do it?

Sports offers young people an outlet to build healthy lifestyles from a young age, develop focus and goals while teaching them social skills and life lessons not taught in schools. Soccer is a sport that any age and any level of skill can play which helps build self-esteem and confidence in young people. More kids play soccer than any other sport, which makes the lack of fields and horrific condition of fields in San Rafael such a crisis. So many soccer dreams have been crushed by ankle and leg injuries on San Rafael and Marin's muddy, pitted and uneven fields.

We have so much to be proud of in San Rafael. San Rafael has led Marin and our region for the last few decades showing how to do development the right way. While other communities just talk about public-private partnerships to build what their city can't afford - but really needs- San Rafael has been putting on a master's class for how to meet the community's needs when the City has limited funds to bring to the table.

Here tonight, looking at this project, it is as if a page of the San Rafael General Plan has just come to life. This project is exactly what the General Plan outlined to meet San Rafael's recreation needs without any taxpayer funds in full recognition that the city doesn't and won't have the funds in the future.

Recreation is in the General Plan because it is an important social, health and physical community need. The need for all weather recreation has grown exponentially in the last 40 years. Creating places to play and recreation opportunities is the one glaring area San Rafael lags behind other communities.

Rarely do officials get to make a single decision that so directly impacts the future health and wellbeing of a community's future like you have the opportunity to do tonight. Tonight's vote will be historic because a yes vote will confirm that San Rafael can implement its General Plan to lead the way in being creative to make sure our community has what it needs despite no



Central Marin Soccer Club

available tax payer dollars. A yes vote will lead to other partnerships with business to solve San Rafael's problems.

The project before you makes sense, building more recreation where recreation already exists today, on land zoned recreation, with an approved EIR showing all issues can be mitigated. This project, with 60 years of safety records and city experts telling you it is a safe project.

Playing soccer next to the airport is something our kids and parents do all the time at McInnis Park here when the fields are open, and at Weisman Park in Petaluma. History is the best indicator of future risk – you have over 50 years of history in the North Bay demonstrating it is safe to have recreation next to these airports. How many more years of evidence do you need?

The risks our parents face while driving to and from games and practices each week far exceed the risks involved playing as they do today at McInnis Park. Every minute there is an accident involving injuries on our Bay Area roads. We don't need 50 years of history to tell us that putting our kids and parents on the road is risky and dangerous. There simply is no safety reason for our city's leaders to turn down this development.

It will provide badly needed recreation fields and facilities so our kids and families can stay in this great town we love. It would not make sense to deny this project for a risk of 1 in 11 million that something would go wrong with an airplane and tell parents that you prefer they continue to drive on Bay Area roads where they have a much greater risk of getting in an accident.

This is an important vote for the direction of San Rafael's future and the legacy you will leave our children and their children. The state is broke, the county has many pressing needs, the schools have limited funds and the city is stretched thin. No other land owners have come forward in all these years offering their land to build these critically needed recreation fields and facilities.

If you vote no tonight, your no vote will end any future recreation projects in San Rafael because no land owners, developers, or citizens will want to partner with the city on recreation after seeing this land owner volunteer to do a good deed for the community that turns into mushrooming costs so high the project is barely economically feasible only to then be voted down after keeping their property tied up for 8 years. Is the City and County ready to step up to the plate and propose a facility paid for the citizens of San Rafael? As much as I would like to see this I doubt it very much.

Rarely do appointed officials get to make a single decision that so directly impacts the future health and wellbeing of a community's future. You have that ability tonight. For our children and their children, please vote for keeping our future bright. Please vote yes on the San Rafael Sports Center.

Sincerely,

Rick Williams, President

BARRETT R.P. SCHAEFER
100 North Avenue, Unit 221
San Rafael, CA 94903

May 31, 2012

Chair Viktoriya Wise & Planning Commission
P.O. Box 151560
San Rafael, CA 94915

Re: North San Rafael Coalition of Residents and the soccer facilities proposal

Dear Ms. Wise and Planning Commission:

At the recent Planning Commission meeting, I spoke to the Planning Commission about a concern I have regarding the North San Rafael Coalition of Residents (NSRCR) organization. I believe this issue is important enough to recap in writing both for the Planning Commission and the San Rafael City Council. While this letter goes somewhat into more detail beyond my three-minute statement to the Planning Commission on Tuesday, it still remains relatively brief and to the point.

In short, my concern is twofold: NSRCR claims (i) it represents literally every resident in northern San Rafael (i.e. the 94903 zip code) and that (ii) it serves as an advocate for every resident that geographic area. This is a concern because it is making strong claims about the proposed new soccer facility on behalf of the entire north San Rafael population without that population's consent.

NSRCR's website at 94903community.org states:

"The North San Rafael Coalition of Residents (NSRCR) serves as an umbrella and advocacy group for **all neighborhoods** in San Rafael and Marin County within the 94903 zip code, north of Puerto Suello Hill." (emphasis added)

In support of this, NSRCR's website also lists approximately 70 neighborhoods and homeowners associations in the 94903 zip code, presumably covering every resident of northern San Rafael.

Now, I understand the great importance of advocacy. It plays an important part of the development and planning process because it helps to ensure the process is thorough, it uncovers issues, and it helps decisionmakers understand who is asserting various points of view. But with NSRCR that process is flawed because it is overlooking a very important point: Not all neighborhoods or homeowners associations are involved in NSRCR. NSRCR has members who

represents and advocates for an entire group of residents – without their consent – rather than just the members of its particular organization.

I have decided not to comment on any similarities this particular circumstance might have with the recent Grady Ranch matter.

Lastly, Carolyn Lenert is the chair of the North San Rafael Coalition of Residents, as evidenced both by NSRCR's website and her signature on the NSRCR letter discussed above. By raising the issues in this letter, I do not intend to imply any intention by Ms. Lenert to engage in misconduct, and this letter should not be seen as a comment on that issue. In fact, I believe raising that issue would distract from the more important issue of who this group actually represents.

Should you have any questions or comments about this letter, feel free to contact me.

Sincerely,

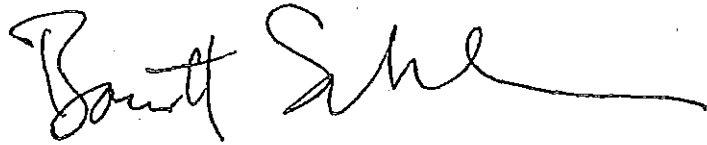
A handwritten signature in black ink, appearing to read "Barrett Schaefer". The signature is written in a cursive style with a long horizontal flourish at the end.

Barrett Schaefer

cc: San Rafael City Council

Kraig Tambornini

From: Steve Stafford
Sent: Thursday, May 31, 2012 9:12 AM
To: Kraig Tambornini
Subject: FW: Please approve the soccer field in San Rafael [I]

FYI

Steve Stafford
CITY OF SAN RAFAEL
Associate Planner
(415) 458-5048
(415) 485-3184 (fax)

Community Development Department, Planning Division
1400 Fifth Avenue
P.O. Box 151560
San Rafael, CA 94915-1560

From: Lisa Vogel [mailto:lisa.vogel@rreef.com]
Posted At: Wednesday, May 30, 2012 6:07 PM
Posted To: Community Development Internet Mail
Conversation: Please approve the soccer field in San Rafael [I]
Subject: Please approve the soccer field in San Rafael [I]

Classification: For internal use only

Please approve the plan for the new soccer field and make a place for our kids to play and grow

Kind regards,
Lisa Vogel



Lisa Vogel

RREEF Real Estate
101 California Street, 26th Floor 94111 San Francisco, USA
Tel. +415(262)2022
Fax +415(781)2229
Mobile +415 317-2059
Email lisa.vogel@rreef.com

A Member of Deutsche Bank Group

This communication may contain confidential and/or privileged information. If you are not the intended recipient (or have received this communication in error) please notify the sender immediately and destroy this communication. Any unauthorized copying, disclosure or distribution of the material in this communication is strictly forbidden.

Deutsche Bank does not render legal or tax advice, and the information contained in this communication should not be regarded as such.

6/1/2012

Kraig Tambornini

From: Steve Stafford
Sent: Thursday, May 31, 2012 9:12 AM
To: Kraig Tambornini
Subject: FW: Sport Complex at San Rafael Airport

FYI

Steve Stafford
CITY OF SAN RAFAEL
Associate Planner
(415) 458-5048
(415) 485-3184 (fax)

Community Development Department, Planning Division
1400 Fifth Avenue
P.O. Box 151560
San Rafael, CA 94915-1560

From: Stocks, Sally [mailto:sally.stocks@invesco.com]
Posted At: Wednesday, May 30, 2012 4:30 PM
Posted To: Community Development Internet Mail
Conversation: Sport Complex at San Rafael Airport
Subject: Sport Complex at San Rafael Airport

This is a fabulous opportunity to create a safe and healthy place for kids to play. I support the project without reservation!

Sally Stocks
Director, Portfolio Management

Invesco Real Estate
101 California Street, Suite 1900
San Francisco, CA 94111
(415)445-3323
sally.stocks@invesco.com

(Please note the name change from Sally Blatt to Sally Stocks)

Confidentiality Note: The information contained in this message, and any attachments, may contain confidential and/or privileged material. It is intended solely for the person(s) or entity to which it is addressed. Any review, retransmission, dissemination, or taking of any action in reliance upon this information by persons or entities other than the intended recipient(s) is prohibited. If you received this in error, please contact the sender and delete the material from any computer.

FW Soccer Complex at Airport.txt

From: Steve Stafford
Sent: Thursday, May 31, 2012 3:53 PM
To: Kraig Tambornini
Subject: FW: Soccer Complex at Airport

FYI

Steve Stafford
CITY OF SAN RAFAEL
Associate Planner
(415) 458-5048
(415) 485-3184 (fax)

Community Development Department, Planning Division 1400 Fifth Avenue P.O. Box 151560 San Rafael, CA 94915-1560

-----Original Message-----

From: Chip Holden [mailto:cholden1957@gmail.com] Posted At: Thursday, May 31, 2012 3:51 PM Posted To: Community Development Internet Mail
Conversation: Soccer Complex at Airport
Subject: Soccer Complex at Airport

To the Planning Commission:

As a long term resident of Marin I Implore you to approve the pending development of the proposed soccer complex at San Rafael Airport. Many interest groups and well reasoned leaders of our community support this worthwhile investment in the enhancement of the quality of life for people of all ages In Marin. Noted supporters have weighed the pros and cons of this facility. By anyone's measure the pros far outweigh the cons including the possibility of a wayward aircraft striking the complex. Yes all factors need to be considered, but the chance of an aircraft straying into the complex is infinitesimally small to almost statistically insignificant.

I strongly support this project and ask you pass it's approval in all due haste.

Sincerely,

Hale "Chip" Holden III

236 Old Quarry Rd N
Larkspur, CA 94939
cholden1957@gmail.com
415/328-4396 (c)

From: Steve Stafford
Sent: Friday, June 01, 2012 7:58 AM
To: Kraig Tambornini
Subject: FW: sports facility
FYI

Steve Stafford
CITY OF SAN RAFAEL
Associate Planner
(415) 458-5048
(415) 485-3184 (fax)

Community Development Department, Planning Division
1400 Fifth Avenue
P.O. Box 151560
San Rafael, CA 94915-1560

From: Bill Conrow [mailto:bill@cambridgespeakers.org]
Posted At: Thursday, May 31, 2012 4:43 PM
Posted To: Community Development Internet Mail
Conversation: sports facility
Subject: sports facility

Dear Planning Commissioners,

I was impressed with the sports/arts complex written about in the IJ the other day. Thinking about how many young people are without parents after school, and with little to do, I think the sports complex would be a great addition for young people in the area. I understand that for various reasons the planning commission has put off a vote on this project. I would recommend that when it does come up for a vote, that it would get the commission's approval.

Sincerely,

Bill Conrow

Kraig Tambornini

From: Linda Nicoletto [lbirdgirl@gmail.com]

Sent: Monday, June 04, 2012 11:06 AM

To: Kraig Tambornini

Subject: San Rafael Airport Rec Facility

Dear Sir,

I want to urge the city to oppose this environmental disaster.

We have lost too much bayland and to develop such a project in low lying baylands would have adverse affects on wildlife and all the tidal species that rely on these disappearing Baylands.

Please stop this project and find a more suitable place.

thank you,

Linda Nicoletto

Kraig Tambornini

From: Steve Stafford
Sent: Tuesday, June 05, 2012 11:25 AM
To: Kraig Tambornini
Subject: FW: The proposed Sn Rafael Airport Sports Complex
FYI

Steve Stafford
CITY OF SAN RAFAEL
Associate Planner
(415) 458-5048
(415) 485-3184 (fax)

Community Development Department, Planning Division
1400 Fifth Avenue
P.O. Box 151560
San Rafael, CA 94915-1560

From: moore.thompson [mailto:moore.thompson@comcast.net]
Posted At: Tuesday, June 05, 2012 11:22 AM
Posted To: Community Development Internet Mail
Conversation: The proposed Sn Rafael Airport Sports Complex
Subject: Re: The proposed Sn Rafael Airport Sports Complex

Daily (at all hours) :
700--1000 persons traveling.
Traffic on 101 (not all local).
Four trips on Smith Ranch Rd.
for those not parking at the lot.

700--1000 visitors depending
on local paramedics, firemen
and the local Sheriff's Dept.

700--1000 "flushes" per day,
in addition to the water use
for operation & maintenance
of this development.

Ann Thompson
707 Hacienda Way
San Rafael, CA 94903
415-472-0287

6/5/2012

ff



TRANSPORTATION ALTERNATIVES FOR MARIN

June 6, 2012

Mr. Kraig Tambornini
Senior Planner
City of San Rafael, Community Development
1400 Fifth Ave, 3rd Floor
San Rafael, Ca 94901

RE: Transportation Alternatives for Marin ("TAM") comments on
the San Rafael Airport Recreational Facility

Dear Mr. Tambornini:

Transportation Alternatives for Marin ("TAM") is a 501(c)(3) non-profit corporation whose mission is to promote pedestrian and bicycle transportation. TAM is submitting written comments in support of robust pedestrian and cyclist access to and at the San Rafael Airport Recreational Facility near McInnis Park. The recreational facility should be as pedestrian and bicycle accessible as possible to reduce automobile traffic and congestion, improve health, improve the environment, and help San Rafael achieve its stated goal of having 20% of its trips made by pedestrians and cyclists by 2020.

Initially we would like to confirm that the Planning Commission is aware of the SMART Multi Use Pathway ("the North South Greenway"), which will be built from Larkspur through Novato (and all the way to Cloverdale) in the next several years. Included in the SMART Multi Use Pathway project is a segment from Larkspur past Civic Center Drive along McInnis Parkway, which then continues north over the creek, possibly between the railroad tracks and the San Rafael Airport and continues north parallel to the railroad tracks past Smith Ranch Road through to Novato. While SMART is still working on the alignment, a likely routing of the SMART Multi Use Path is shown in Exhibit "A." The bicycle and pedestrian access to the San Rafael Airport Recreational Facility should be near the intersection of the SMART Multi Use Pathway and Smith Ranch Road.

With this letter, TAM recommends that the proposed pedestrian and bicycle improvements be made as shown in Exhibit "B." These improvements will connect the SMART Multi Use Path and the San Rafael Airport Recreational Facility with the North South Bikeway, Marinwood, Lucas Valley and Mont Marin communities and will facilitate safe pedestrian and bicycle access. TAM recommends that the traffic mitigation fees for the project be used to widen the sidewalks on the south side of Smith Ranch Road to 8 feet and to plan and construct the Single Directional Bike Lanes on each side of Smith Ranch Road from Redwood Highway to the entrance of McInnis Park (which would be the SMART Multi Use Path).



TRANSPORTATION ALTERNATIVES FOR MARIN

TAM also recommends that the Recreational Facility incorporate safe and separate access for pedestrians and cyclists to and between the Facility's primary activity centers and bicycle parking once there.

TAM strongly recommends that the Planning Commission and the City of San Rafael support the above pedestrian and bicycle access from the North South Greenway with continuous, safe and separate pathways that enable people to access the Soccer Complex Recreational Facility without automobiles. The proposed Single Directional Bike Lanes on Smith Ranch Road creates access to the project and ties into the North South Greenway to route non-motorized access to the soccer complex.

If you have any question about this letter please do not hesitate to contact me.

Respectfully submitted,

Patrick M. Seidler
President

cc: San Rafael City Council
San Rafael Department of Public Works
Marin County Bicycle Coalition

Exhibit "A"

Future North South Greenway







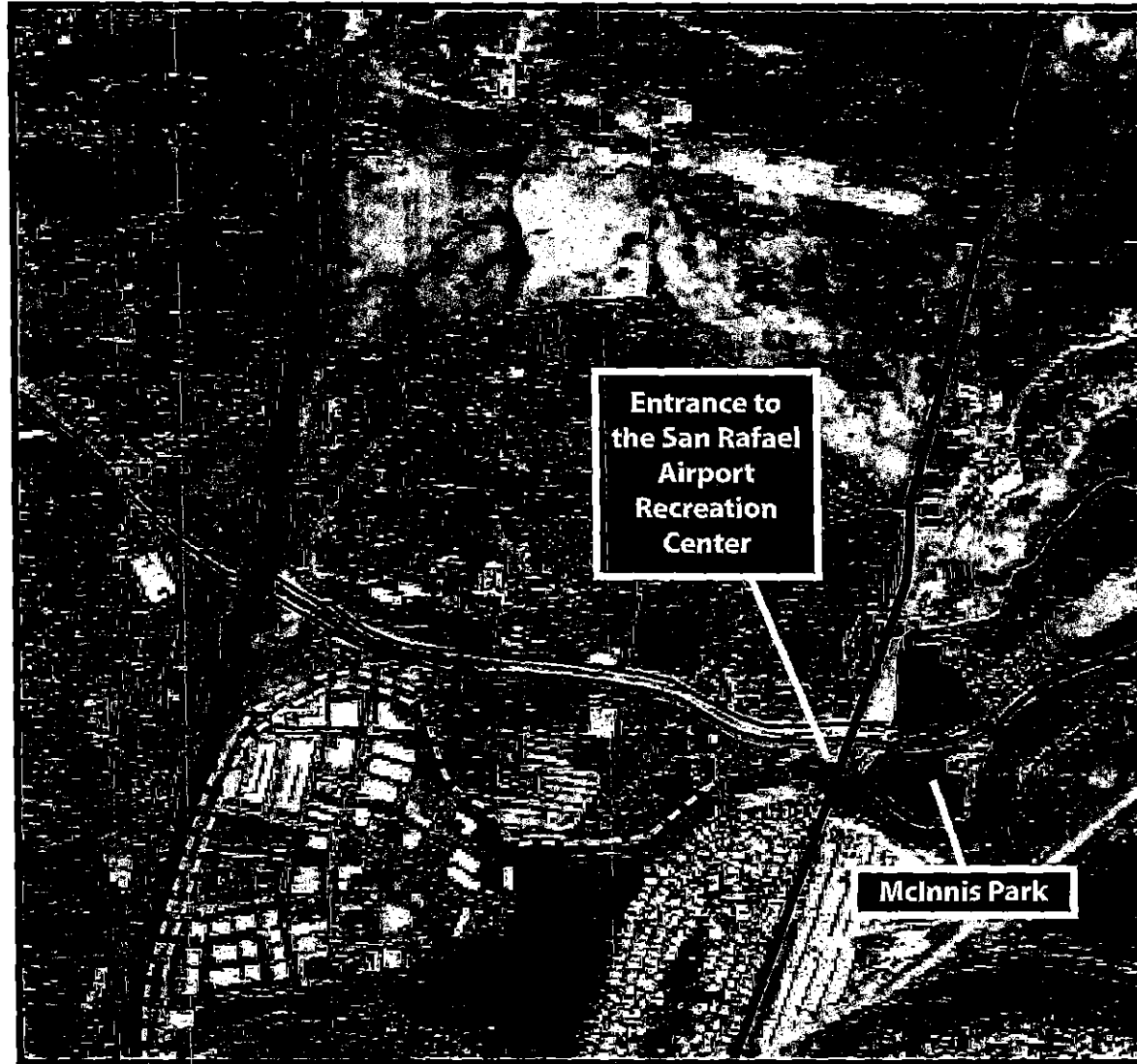

Future North South Greenway
(SMART Multi Use Path)

Exhibit "B"

Marinwood / North San Rafael Proposed Pedestrian and Bicycle Improvements



-  Proposed Caltrans 1003.5 Multipurpose Trail (Separated Pathway)
-  Proposed Caltrans 1003.5 Multi-purpose Trail (Separated Pathway)
-  Future North-South Greenway (SMART)
-  Future Class II Bike Lane
-  Existing Caltrans 1003.5 Multi-purpose Path
-  Widen Sidewalk to 8'
-  Proposed Caltrans 1003.1(i) One Way Separated Class I Bike Path

FW San Rafael Contact Email - 6683275.txt

Esther Beirne, City Clerk

415 485-3065

P Think of trees before you print please.

From: form_engine@fs18.formsite.com [mailto:form_engine@fs18.formsite.com]

Sent: Tuesday, June 12, 2012 12:36 AM

To: City Clerk

Subject: San Rafael Contact Email - 6683275

San Rafael Contact Form

**City of San Rafael
Email Contact Form**

Thank you for visiting the City of San Rafael web site. This form is intended for communicating with City of San Rafael staff. Your input will be forwarded to the appropriate staff member for their attention during regular business hours.

Note that the City of San Rafael considers email to staff as informal communication. Please send a signed letter if you prefer to make your comment/question a matter of public record. Mail formal letters to PO Box 151560, San Rafael, CA, 94915.

*** First Name
Kelly**

*** Last Name
Atwood**

**Address 1
282 Carlsbad Court**

**Address 2
-**

**City
San Rafael**

**State
CA**

**Zip Code
94903**

**Phone Number
4155054289**

*** Email Address
katwood5000@gmail.com**

FW San Rafael Contact Email - 6683275.txt

**Send To
CityClerk**

*** Please enter your questions/comments below**

Mrs. Terwilliger came in to my class room over 40 years ago and nature has been my first choice ever since. The Terwilliger Nature Center had a brown bear (in 1969). Which decisions did the City Council make prior to that year that eventually destroyed the bear population in the area?!

The beauty of living in Contempo Marin in Northern San Rafael is that most late nights, when all is quiet I can hear the howl of one or more coyotes. This is magic, and so is the entire area along Gallinas Creek.

The airport needs to expand its acreage to wetland, not ASPHALT. Just barely making a come back, we need to allow quail, and other birds to thrive, not be disrupted. We need to embrace the serenity of the area. Have you spent time riding along the creek?

I rode my bike on the bike trail past the airport entrance and wondered how horrible traffic will be from game attendees, and employees. It will be a down right shame that City Council and planners did not put our natural resources first. The facility should be near Home Depot and Target.

Lights, noise and traffic will impact everyone and everything. How much road kill do I find throughout the month.

The facility is in a prohibited area according to the 2011 Airport Handbook.

Historic bayland properties should be returned to tidal marsh as recommended by BCDC, SFEI and other bay conservation agencies.

Vehicle traffic will create breathing problems for those of us who have asthma and like to walk and ride a bike.

Obstruction lighting will impact marsh and dark skies and neighborhoods

Parking lot, cars, and plastic turf will put more pollution into the marsh as the area needs to be pumped out or it floods at every rainstorm

Why hasn't this project been shut down?!

We do not need any more noise and light pollution, toxic runoff, increased traffic and excessive disturbance to ourselves and to the marsh and creek next door. This project belongs nearer to transportation and far from fragile wetlands.

Kraig Tambornini

From: Esther Beirne on behalf of City Clerk
Sent: Wednesday, June 13, 2012 2:30 PM
To: Kraig Tambornini
Cc: Paul Jensen
Subject: FW: San Rafael Contact Email - 6683275

Fyi - I have not responded.

Esther Beirne, City Clerk
415 485-3065



Think of trees before you print please.

From: form_engine@fs18.formsite.com [mailto:form_engine@fs18.formsite.com]
Sent: Tuesday, June 12, 2012 12:36 AM
To: City Clerk
Subject: San Rafael Contact Email - 6683275

San Rafael Contact Form

City of San Rafael ***Email Contact Form***

Thank you for visiting the City of San Rafael web site. This form is intended for communicating with City of San Rafael staff. Your input will be forwarded to the appropriate staff member for their attention during regular business hours.

Note that the City of San Rafael considers email to staff as informal communication. Please send a signed letter if you prefer to make your comment/question a matter of public record. Mail formal letters to PO Box 151560, San Rafael, CA, 94915.

*** First Name**

Kelly

*** Last Name**

Atwood

Address 1

282 Carlsbad Court

Address 2

-

City

San Rafael

State

CA

Zip Code

94903

Phone Number

4155054289

*** Email Address**

katwood5000@gmail.com

Send To

CityClerk

*** Please enter your questions/comments below**

Mrs. Terwilliger came in to my class room over 40 years ago and nature has been my first choice ever since. The Terwilliger Nature Center had a brown bear (in 1969). Which decisions did the City Council make prior to that year that eventually destroyed the bear population in the area?!

The beauty of living in Contempo Marin in Northern San Rafael is that most late nights, when all is quiet I can hear the howl of one or more coyotes. This is magic, and so is the entire area along Gallinas Creek.

The airport needs to expand its acreage to wetland, not ASPHALT. Just barely making a come back, we need to allow quail, and other birds to thrive, not be disrupted. We need to embrace the serenity of the area. Have you spent time riding along the creek?

I rode my bike on the bike trail past the airport entrance and wondered how horrible traffic will be from game attendees, and employees. It will be a down right shame that City Council and planners did not put our natural resources first. The facility should be near Home Depot and Target.

Lights, noise and traffic will impact everyone and everything. How much road kill do I find throughout the month. The facility is in a prohibited area according to the 2011 Airport Handbook.

Historic bayland properties should be returned to tidal marsh as recommended by BCDC, SFEI and other bay conservation agencies.

Vehicle traffic will create breathing problems for those of us who have asthma and like to walk and ride a bike.

Obstruction lighting will impact marsh and dark skies and neighborhoods

Parking lot, cars, and plastic turf will put more pollution into the marsh as the area needs to be pumped out or it floods at every rainstorm

Why hasn't this project been shut down?!

We do not need any more noise and light pollution, toxic runoff, increased traffic and excessive disturbance to ourselves and to the marsh and creek next door. This project belongs nearer to transportation and far from fragile wetlands.

Kraig Tambornini

From: Sarjit Dhaliwal
Sent: Wednesday, June 20, 2012 7:43 AM
To: Kraig Tambornini
Subject: FW: Sports complex in marin

Another one.

From: Marianne Jacobson [mailto:marianne_jacobson@sbcglobal.net]
Posted At: Tuesday, June 19, 2012 2:06 PM
Posted To: Community Development Internet Mail
Conversation: Sports complex in marin
Subject: Sports complex in marin

Marin Planners

I strongly support a state of the art sports facility for kids in Marin!
It is embarrassing how many games our kids have to play in the east bay because we do not have adequate fields in Marin.

TY
Concerned Citizen
Marianne Jacobson
Ross

Sharonne Chevalier Skolnikoff, Ph.D.
812 Flaxberry Lane
San Rafael, CA 94903

Kraig Tamborini
and
Members of the City Council
c/o San Rafael City Hall
1400 5th Avenue
P.O. Box 151560
California 94915-1560

RECEIVED
JUN 1 1993
COMMUNITY DEVELOPMENT
CITY OF SAN RAFAEL

Re: Proposed development of a Private Recreational
Facility on Airport Property adjacent to the
Wetlands Preserve

Dear Mr. Tamborini and Members of the City Council,
I am writing to express my opposition to
the proposed project to build a Private Recreational
Facility on the Airport property adjacent to the
Wetlands Preserve.

The proposed development would add
noise and impinge on the views and relative
solitude of the area. The height of the proposed
building and the removal of any of the Eucalyptus
trees would be especially damaging to the views.

Furthermore, additional traffic would
be detrimental to the relative solitude of the
area where one rarely sees more than
three or four people during a half-hour to
one-hour visit.

I also believe it is inappropriate to
allow any further development on landfill
adjacent to an ecologically sensitive Wetlands
Preserve as it would be very disruptive to
the wildlife that inhabit and pass through
the area.

Besides all the above, I believe it is
unadvisable to build on these low-lying areas

considering that the sea level will be rising and the areas will have to be abandoned or someone will have to great expense to build higher levees to protect them.

Personally, I am somewhat disabled and even though there is a lot of open space in Marin most areas near me are too difficult for me to negotiate. Visiting this beautiful area several times a week is really important to my quality of life and was one of the reasons I chose to live in this area.

Thank you for your consideration of my views.

Sincerely,
Anganne Chevalier Skolnikoff

Kraig Tambornini

From: Kraig Tambornini
Sent: Monday, July 02, 2012 12:06 PM
To: Kraig Tambornini
Subject: San Rafael Airport Council Hearing Comments

TO -

Staff has tentatively scheduled the airport recreational facility project for a public hearing on Monday, August 6 at 7PM, San Rafael City Hall. This hearing date will be firmly established the week of July 16. A revised notice will be mailed, published and posted.

The hearing will be on A) the FEIR Certification and B) Project Zoning Entitlements, as recommended by the Planning Commission at its January 24 and June 6 meetings. The zoning entitlements include:

- A revised **PD Zoning** plan to adopt standards for recreational development
- A revised **Master Use Permit** to add conditions for the proposed recreational uses, and
- An **Environmental and Design Review Permit** to permit the new building and site improvements).

The Council will review the substantial amount of testimony already received on the project at the previous public hearings held by the Design Review Board and Planning Commission. Speaker time limits will be enforced for applicant presentation and public comment. Since there have been multiple hearings held for the project the Council may also decide to limit the total amount of time allotted for receiving additional public testimony on the project. Thus, it is important for groups to be prepared to provide its message as clearly and succinctly as possible (of course, individual members may continue to exercise their opportunity speak independently and write their own letters).

I would offer my suggestion that interest groups should consider designating a spokesperson for their group to provide its comments focused on the two main subject areas, i.e. Environmental Review and Project Merits Review. Comments that are organized and focus on any pertinent and outstanding, revised or new concerns should help the Council to more clearly receive the information before making its decision on the project.

Please feel free to contact me if you have any questions about the contents of this message or the upcoming meeting.

Sincerely,

Kraig Tambornini, Senior Planner
City of San Rafael, Community Development
1460 Fifth Ave./PO Box 151560
San Rafael, CA 94901/94915-1560
Phone: (415) 485-3092
Fax: (415) 485-3184
Kraig.Tambornini@cityofsanrafael.org

Independence Day, 2012

Christine Kraemer
75 Vendola Drive
San Rafael, CA 95903

JUL 05 2012

Marc Levine, Councilmember
City of San Rafael
1400 Fifth Avenue
PO Box 151560
San Rafael, CA 94915-1560

Cc: Gary O. Phillips, Mayor
Damon Connolly, Councilmember
Barbara Heller, Councilmember
Andrew McCullough, Councilmember

Dear Marc:

Thank you for inviting my input on the proposed airport soccer complex. I live on Vendola Drive and would be severely impacted by the noise and light pollution, let alone the pile driving/construction. The safety issue of planes landing in close proximity to children playing soccer is unthinkable. The environmental impact concerns have not been sufficiently mitigated by a long shot, including impact on the kite bird and the federally-protected and endangered Clapper Rail that I can now enjoy from my backyard. And there is no question that the original plan/agreement for this land would be overridden.

I have friends who have lived in Santa Venetia for decades who are so distressed by this prospect that they plan to move out of the neighborhood if this goes through.

The question is - who has the most important voice here - the neighborhood residents who will bear the brunt of the effects of this disastrous plan for the rest of their lives here, and who have raised multiple valid environmental and safety issues that have not been reasonably mitigated? Or a developer with wink and nod relationships with local commissioners and elected officials, and who wishes to make money at all costs and clearly is unconcerned with the best interest of the community, who has sued residents in the past, claiming he owns the creek...?

There is of course the view that Santa Venetia residents do not vote for City Council in San Rafael and therefore should only have a muted voice. But I feel it is only just that those most impacted and those standing up for environmental statutes should have a large, or at an least equal voice. Ultimately, will this go the direction of Citizens United and give the greater voice to the already moneyed and powerful, and rubber stamp the wishes of this wealthy developer with buddies on the Planning Commission and whom Steve Kinsey literally winked at after voicing his support for the project?

This will be a test of what kind of democracy does or doesn't exist in the City of San Rafael.

I will also refer some of my neighbors who have been working diligently for years on this to you for additional facts that may or may not show up in the staff report.

Thank you, again, for inviting my input on this topic, Marc. I will share it with your fellow councilmembers, as well.

Sincerely,

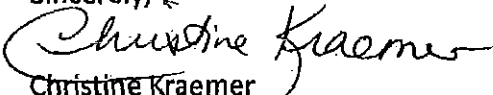
Christine Kraemer



Smith Ranch Homes
HOMEOWNERS' ASSOCIATION

JUL 16 2012

July 13, 2012

San Rafael City Council
1400 Fifth Avenue
P.O. Box 151560
San Rafael, CA 94915-1560

To the members of the San Rafael City Council:

Smith Ranch Homes Homeowners' Association wishes to reiterate its opposition to the proposed recreational development next to the runway at the San Rafael Airport. Enclosed is a copy of the letter that our Board President forwarded to the Planning Commission on December 16, 2011 stating the reasons for our opposition. Those reasons continue to apply to the proposal in its present form.

We strongly urge you to disapprove this proposal.

Respectfully,

John A. Busterud, Chairperson
Community Relations Committee

CC: Board of Directors



Smith Ranch Homes
HOMEOWNERS' ASSOCIATION

December 16, 2011

Community Development Department-Planning Division
City of San Rafael
P.O. Box 151560
San Rafael, CA 94915-1560

Attention: Kraig Tambornini, Senior Planner

Re: San Rafael Airport Recreational Facility FEIR

Dear Planning Commissioners:

On behalf of the Board of Directors of the Smith Ranch Homes Homeowners' Association ("the Association"), I write to urge the Commission to reject entirely the proposed Airport Recreational Facility. For the reasons stated below, the Association supports the large group of San Rafael residents and organizations that are opposed to the project.

1. The proposal is designed to be much more than a mere recreational use, whether "public" or "private", and more than a soccer facility. It would be built and operated for profit-making purposes and should be recognized and regulated as a commercial use, for which the Airport site is not an appropriate location.
2. The contemplated development would have a heavy adverse impact on the sensitive natural areas, including wetlands, which directly adjoin the Airport site.
3. The impact on local traffic and parking, the planned density and extended daily operating periods, and the intention to develop a facility serving the whole of Marin County, are features that clearly contravene the intent of the Declaration of Restrictions, and will adversely affect the residential developments that have been erected in the area north of the Civic Center, in reliance upon the Declaration.
4. The Association represents more than 300 San Rafael residents and condominium owners, who all live in the area near the Airport, and who operate collectively the 30 acre independent living facility known as Smith Ranch Homes. That facility and all its residents would also be directly and adversely affected by the Airport Recreation Project and the high density of use for which it has been designed.

We believe the FEIR is inadequate because it does not sufficiently address the concerns we have indicated. Thank you for considering our opinion.

For the Board of Directors:

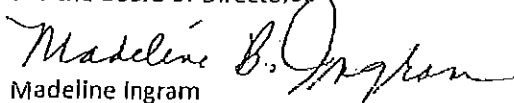
Madeline Ingram
President

Attn: Gary O. Phillips, Mayor
Marc Levine, Councilmember
Damon Connolly, Councilmember
Barbara Heller, Councilmember
Andrew McCullough, Councilmember

C/o Kraig.Tambornini@cityofsanrafael.org

July, 26, 2012

Re: AIRPORT SOCCER COMPLEX

Granted there is a need for soccer fields in Marin—no one is disputing that. But does that need have to be met by constructing a virtual mini-mall for indoor courts, space for other sports activities, offices, cafes and a restaurant catering for parties with alcohol served? The answer is a big “NO”. There are very good and viable alternatives. There are 7 existing soccer fields in the area, which the children and their parents at the last Planning Commission meeting complained were not playable due to neglect and disrepair. That is fixable, and could be accomplished by a creative public-private partnership. (Such as is being proposed for the North Approach Civic Center Rejuvenation). An alternative for indoor courts could be the conversion and use of buildings empty now in San Rafael. Or one can consider an almost- permanent tent similar to the sturdy ones that are so successful at the County Fair.

These alternatives would answer the need for soccer fields:

Without enlarging the footprint, thereby keeping Marin “green”.

Take the children away from the danger of aircraft

Eliminate the intrusion of heavy traffic (almost 24/7) through a settled neighborhood

Do away with the proposed strong, high lighting –a threat to hundreds of people living nearby

But the most damning aspects of the proposed Complex are the total death of the Gallinas Creek watershed, the loss of the wetlands so vital to the life of a multitude of birds and water creatures, especially the endangered Clapper Rail, and the complete change to the peaceful hamlet of Santa Venetia.

In a world where so much is being eroded away, people are crying out to save what is so important to the environment, this earth, and our very civilization. Honorable organizations such as the Marin Conservation League, the Audubon Society the Gallinas

Watershed Authority as well as thinking, conscience-driven people are begging you to deny this unnecessary travesty.

I trust your collective Sense and Sensibilities will guide you in this: do not certify the FEIR and do not approve zoning changes for this valuable wetlands area.

Yours truly,

Mary Louise King

Kraig Tambornini

From: Elaine Reichert [g.r-elaine@comcast.net]
Sent: Friday, July 27, 2012 10:45 AM
To: Kraig Tambornini
Subject: For Aug 6 hearing

Elaine Reichert
1605 Vendola Drive
San Rafael, CA 94903

July 27, 2012

San Rafael City Council Members
City Hall, 1400 Fifth Ave.
San Rafael, CA 94901

Honorable Council Members:

Please consider your response to the proposed re-zoning of the San Rafael Airport very carefully. This parcel was set aside with covenants and restrictions against further development to mitigate the loss of wetland habitat when Marin Lagoon, Embassy Suites and Autodesk parcels were developed by this applicant.

Sadly, the proposed sports facility will not benefit the children of San Rafael. It is a strictly commercial operation that will only be available to its own leagues and paying players.

If the time and energy spent showcasing the many negative impacts of this proposed project had instead been available to generate public/private partnership funding to upgrade the many existing public fields at schools and parks, the people of San Rafael would have many safe, useable fields in their own neighborhoods. This is still possible and a far better option than ruining watershed habitat.

Surely when the City makes a promise to protect an area from development, we should be able to rely on them to uphold their promise. The commercial re-zoning in the proposal before you violates the covenants allowing recreation by including office, retail and food service facilities.

Given that the applicant has already renamed the parcel San Rafael Airport and Business Park, one has to realize that further commercial development will soon follow if the restrictions on the parcel are removed.

Please uphold the covenants and restrictions on this parcel and deny this proposed facility.

Thank you for your consideration of the many negative impacts this project will have.

Sincerely,

Elaine Reichert

Kraig Tambornini

From: Marin Info [Info@MarinInfo.org]
Sent: Saturday, July 28, 2012 11:41 AM
To: Kraig Tambornini
Subject: Aug 6 SR Airport Sports Complex comments from Alan Scotch

Dear Kraig,

Could you please add these **brief** comments and email this webmail to City Council members

-- so they can just click and go to webpage MarinInfo.org menu: "SR Airport" for elaboration of issues raised (including MCL & Audubon) ?

- Clapper Rail Habituation to noise and lights is not proven. See link to Clapper Rail Locations (on above website) showing how the road to the Sports Complex would create Clapper Rail DISTURBANCE along the length of the upper creek. There would be constant presence of crowds of people, many with dogs, increased noise, lights, and litter in low-lying **Baylands**.
- Caltrans Letter detailing **obstructions to air navigation** must not be ignored.
- **Deed Restriction** intent was a balance of allowing development in one location -- for NO comparable development in the airport. Several local politicians of the time, corroborate this. The *intent* of the covenant, was to limit development and human activities, not to intensify development.
- Indoor soccer needs can be met from other locations that would not disturb the environment. (see list on webpage)
- A possible COMPROMISE: Instead of a huge building in such a sensitive area and to cater for the more pressing need for OUTDOOR soccer, relative to INDOOR -- build a little footbridge connecting the McInnes soccer fields to 3 soccer fields on the airport , instead of just the ONE soccer field of this project.

Thanks,
Alan Scotch
San Rafael

Aug 6 comments from Alan Scotch.txt

From: Marin Info [Info@MarinInfo.org]

Sent: Saturday, July 28, 2012 11:41 AM

To: Kraig Tambornini

Subject: Aug 6 SR Airport Sports Complex comments from Alan Scotch

Dear Kraig,

Could you please add these brief comments and email this webmail to City Council members

-- so they can just click and go to webpage MarinInfo.org menu:"SR Airport" for elaboration of issues raised (including MCL & Audubon) ?

- **Clapper Rail Habituation to noise and lights is not proven. See link to Clapper Rail Locations (on above website) showing how the road to the Sports Complex would create Clapper Rail DISTURBANCE along the length of the upper creek. There would be constant presence of crowds of people, many with dogs, increased noise, lights, and litter in low-lying Baylands.**

- **Caltrans Letter detailing obstructions to air navigation must not be ignored.**

- **Deed Restriction Intent was a balance of allowing development in one location -- for NO comparable development in the airport. Several local politicians of the time, corroborate this. The intent of the covenant, was to limit development and human activities, not to intensify development.**

- **Indoor soccer needs can be met from other locations that would not disturb the environment. (see list on webpage)**

- **A possible COMPROMISE: Instead of a huge building in such a sensitive area and to cater for the more pressing need for OUTDOOR soccer, relative to INDOOR -- build a little footbridge connecting the McInnes soccer fields to 3 soccer fields on the airport , instead of just the ONE soccer field of this project.**

Thanks,

Alan Scotch

San Rafael

Kraig Tambornini

From: Mary Hanley [maryinmarin@comcast.net]
Sent: Saturday, July 28, 2012 12:45 PM
To: Kraig Tambornini; Gary Phillips; Damon Connolly; Barbara Heller; Marc Levine; Andrew McCullough; City Council
Cc: Michael McCrea
Subject: San Rafael Airport Recreational Facility - Comment Letter from Michael McCrea

From: Michael McCrea [mailto:farmboyflyer@att.net]
Sent: Saturday, July 28, 2012 9:30 AM

July 29, 2012

The Airport Sports Development

Honorable members of the San Rafael City Counsel;

In addressing AVIATION SAFETY, The Planning Commission was presented with a letter from the California Department of Transportation Division Of Aeronautics recommending this project be Prohibited* under 'Group Recreational Use' within the danger zones it is sited for. **(*Prohibited: Use should not be permitted under any circumstances.)**

Despite the easily accessible evidence of numerous light plane accidents and the potential for accidents into these danger zones the Planning Commission basically punted this dilemma of safety on to you... using, as a cover for the vote to move it to you, the OPINIONS, not FACTS by applicant and legal counsel. These 'opinions' twist and distort basic facts.

One need only transpose the proposed application to see how very distorted the argument of the project being located in a "SAFE" location has become.

Imagine the parcel of real estate void of the airport; but the Sports Development is in full operation in its proposed location with hundreds of children playing in the unreinforced building and on the open playing fields.

Now imagine the developer making application to place a narrow runway, which will be utilized by up to a hundred aircraft, operated by pilots of wide and diverse qualifications, closer to those unprotected children than any such development in the United States.

Would that application be given series consideration? We know it would not.

THE REASON BEING; PLACING INNOCENT CHILDREN IN KNOWN HAZARDOUS CONDITIONS IS UNACCEPTABLE! THE PROPOSED PROJECT AND THE AIRPORT ARE NOT COMPATIBLE WITH THIS BASIC PRINCIPLE OF OUR SOCIETY.

This principle, not whether the development incorporates such and such density of use, or contains fixed bleachers, etc., (as incorporated in argument by the developer); **The fact of placing groups of innocent children into known and documented hazardous areas, is cause for the project to be PROHIBITED.**

Here are some facts;

1. The recreational facilities located at other airports, cited by the applicant as examples "of safe similar operations", were nearly all "grandfathered in" before scientific data was available. None of them are 'similar' in incorporating the enormous unreinforced structure proposed which because of it's size and location will distort normal flight activities on the runway..further INCREASING the potential for an accident!

2. NONE of the cited 'Similar examples' have the intensity of hourly use, or the extreme close proximity to the runway as the proposed development. This is a runway that does not even incorporate a parallel

7/30/2012

taxiway. The primary safety feature of construction requirement for all 'public use' airports.

3. The applicant stated in a letter to the San Rafael Planning (May 23, 2012); "...The average person has a 1 in 88 chance of being injured or killed in an automobile accident compared to only 1 in 88 million for an airplane crash." but, he fails, or purposely omits, the statistics from the NTSB, that eliminate the Commercial Airlines with their strict regulations of runways, precise calibrated navigational aids, professional pilots and maintenance.

These statistics, collated from data reflecting conditions similar to the San Rafael Airport, show a much higher risk factor and potential for disaster than the developer and legal staff would have you believe.

The National transportation Safety Board data for *General Aviation aircraft*, calculates your chances of being killed 'mile for mile' for general aviation aircraft travel is 8.9 times greater than automobile travel, and in hour by hour travel your chances of being killed in a general aviation accident are **21 times greater than an automobile.**

4. Over two-thirds, 68 % of all aircraft accidents occur on or near an airport with a full 27% of those accidents occurring in the danger zones where the applicant proposed to place this development! (reference NTSB; FAA, and CALUPH *).

The zones where the Parking lot, building, and warmup field are proposed would historically record a greater number of more serious accidents except these areas .. "are normally kept clear of development or used for airport low density use only." (FAA/NTSB)

The applicants statement of your children being safer playing in the two of the most dangerous zones at this airport (where the development is proposed) than traveling to it by automobile are blatantly false. Under his criteria and logic; the runway itself would be of very limited hazard, since statistically almost no pedestrians have been killed while on a runway.

5. Among the most specious of arguments used by the applicant is in asserting the San Rafael Airport is somehow exempt from the many decades of scientific accident study, analyses and safety conclusions by the Division of Aeronautics due to the fact that it is a "Private Airport", and the handbook only applies to Public Use Airports...as if somehow the risk factors and the laws of physics are suspended with this 'special' airport'. In fact this airport incorporates many risk factors not found at most airports and the proposed facility will increase the hazards of glare, obstructions, airflow distortion, etc., and thereby increase the risk of a disastrous accident.

6. The applicant claims, the San Rafael Airport, which harbors up to one hundred aircraft, is "one of the smallest and quietest private use airports in the state." This despite statistics which show this airport falling into the top 2% of private airports in capacity... and only 24% of Public airports have greater capacity.

This on an airport which lacks many safety features of a public airport and most private airports, therefore increasing the potential for an accident. Under the Shield of 'Private Airport' the applicant has hidden many accidents and incidents from public knowledge and violated many of the conditions of the 'Use Permit'.

7.. The number of flight operations, stated by the applicant in the same letter; " On most days the total number of flights at the San Rafael Airport can be counted on one hand."

Really? Well, that could easily be verified by the historic video recordings required by the City in the 'Use Permit.'; but like many other provisions of the permit which have been ignored or violated over the years. The recordings have not been consistently produced or preserved. Had this 'condition of use' been adhered to; We could observe the multiple "actual" accidents and incidents which have occurred at the field.

With a hundred aircraft based at the airport, should not we look at the potential number of operations, not just those operated during this distressed economy? The applicants own statistics state up to 15,000 flight operations per year. (EIR)

7. Of all the mitigations which were suggested by the CALUPH for RISK REDUCTION THROUGH BUILDING DESIGN; only two, a single extra exit door and upgrading the fire sprinkler system have been proposed for mitigation. Both mitigations designed for limiting the consequences AFTER a catastrophic impact occurs, and do nothing to mitigate the initial impact of an aircraft INTO the development... IN FACT, rather than "limiting the size and number of windows" to minimize initial impact risk, a mitigation proposed by the CALUPH, the building design incorporates many huge 'viewing windows' with no structural integrity, **increasing the risk** that an impacting aircraft will enter the structure and disastrously impact the occupants INSIDE!

8. One of the most distressing factors for this development with regards to safety is addressed in the Cal Trans letter; **"In general, society gives special attention to protection of children. Special consideration should be given to facilities which cater to children such as recreation and sport facilities," (CALUPH)**

Let us not be naïve in the potential for untold tragedy likely to occur at this facility.

How can we justify securing our children in car seats or seat belts to travel to the proposed development and then place them in known danger zones, close to an narrow active runway, which up to a hundred aircraft operate from, without even a safety helmet?

The incompatibility of placing this project into these documented hazard zones boggles the imagination.

As we have seen in the vetting of this project; The political discussion of Aviation safety soon degenerates into 'What can we get away with?' and 'For how long?' (IBG/YBG...I be gone, you be gone)

Michael McCrea
Professional Pilot
San Rafael

* CALUPH..California Airport Land Use Planning Handbook

Kraig Tambornini

From: eldek@comcast.net
Sent: Sunday, July 29, 2012 2:07 PM
To: Kraig Tambornini
Subject: Extenet Project

Hi, I live at 1959 Las Gallinas, we met at the last meeting and thank you for taking on more conversation about this project. I don't agree with making the 1959 poll taller than the rest of the poles along Las Gallinas. From what I understand the poles are now 38 feet and the new pole will be 42 feet (not sure if this height includes the node or if the node is added to the 42 foot pole, which would obviously make it higher than 42 feet). Again it all boils down to aesthetics for the whole of the project and if this must be, I do agree with putting the boxes under ground but I don't agree with making the selected pole (s) taller than the rest of the poles that run along Las Gallinas.

As far as the 1959 pole, which houses my electrical power, I would also like some clarification about how this will effect any kind of power outage as these poles are installed. Also, as time goes on and problems occur, how does this effect the now 4 houses involved? Will the power have to be turned off in order for the work on the nodes to be completed? Will there be power outages, and if so for what duration? Will they be working with PG&E etc?

I still don't understand how and why these poles were selected, especially with all this open space. I think it is unfair but I can only speak for myself, and I feel that our household has been forcibly singled out to bear with this. In the big scheme of things, the now 4 houses involved stand alone. Will this effect our property values? I have not contacted a Realtor to find this out. I would like these issues addressed with me, so that I know what to expect. I don't think I am being selfish, this is my home and the pole selected is attached to my house. This has been very stressful, and I feel like I have no choice but to put up with the unknown problems that come attached with this, i.e., even taking the time to write this e-mail is more than I wanted to do on this Sunday afternoon. Trouble as come knocking on my door and it seems that all I can do at this time is stand up and sound off!

Thank you for your time,

Sam and Eleanor Dekelaita
1959 Las Gallinas
San Rafael, CA 94903
(415)479-2274

July 30, 2012

San Rafael City Council
c/o Community Development Department
P. O. Box 151560
San Rafael, CA 94915

Re: San Rafael Airport Recreational Facility Access Bridge

Dear City Council Members,

By now, all of you have taken at least one trip out to the San Rafael Airport property and crossed/seen the current access bridge.

On numerous occasions, the applicant has stated that the closest any home is to the proposed project is ¼ mile. What has conveniently been avoided by the applicant is that the *access bridge* to the airport property is, in fact, merely just a *few yards* away from Captain's Cove Condominium Complex.

If the project is approved as is, the hours of operation and the over 1700 vehicle crossings expected each day at the facility will make this bridge completely inappropriate – even if it's widened. It will most certainly promise non-stop traffic noise to Captain's Cove residents, and after dark it will mean not only traffic noise but will mean continuous headlights into these homes until well after midnight. Then there is the safety aspect of the twists and turns of the road to and from the current bridge. This multiplied (especially at night) by soccer players who have had a few beers is most certainly a recipe for disaster in regards to noise and safety.

During the June 6, 2012 Planning Commission Discussion of Merits, Commissioner Lang even stated that she did not like the location of the bridge and that it would be much better located closer to McGinnis Park. This has been discussed in the past, but the applicant has gotten away with saying "there's nothing we can do about it; it's the County's property." This is unacceptable. In no forum of the Community Development process has there been requirements placed on the applicant in regards to moving the bridge. Adding a little fence and some bushes is not sufficient. If this is to be a state-of-the-art facility as the applicant keeps boasting, than the City should require they make accommodations for properly located access.

I ask that the City Council not let this matter go unattended.

Thank you for your attention to this issue.

Kind regards,

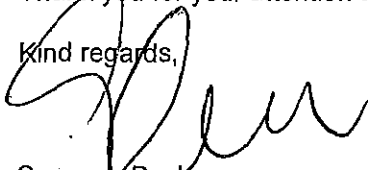

Susanna Becker
97 Dockside Circle
San Rafael, CA 94903

Kraig Tambornini

From: In Support of the San Rafael Airport Recreation Facility Project [no-reply@wufoo.com]
Sent: Monday, July 30, 2012 3:31 PM
To: dist2@letmarinplay.com; lmanchip@yahoo.com
Subject: Thank you for your time. [#308]

Name * Cindy Riley

Email * anindigomom@yahoo.com

Message to the Planning Commission *

Hi,
I just wanted to voice my family's support of the S.R. Rec Facility project. We have two children in the Dixie school district and we welcome the Sports Complex! We live at 98 Upper Oak Dr. Thank you. The Riley Family

Kraig Tambornini

From: In Support of the San Rafael Airport Recreation Facility Project [no-reply@wufoo.com]

Sent: Monday, July 30, 2012 4:57 PM

To: dist2@letmarinplay.com; lmanchip@yahoo.com

Subject: Thank you for your time. [#309]

Name * aNNE SCHERR

Email * ADSCHEER@GMAIL.COM

Message to the Planning Commission * Please seriously consider voting yes on the S.R. Airport Sports Complex. It will serve so many and so many will support it.

Many thanks,
Annie Scherr

Kraig Tambornini

From: Joyce Clements [coastalartworks@yahoo.com]
Sent: Tuesday, July 31, 2012 11:43 AM
To: Kraig Tambornini; Gary Phillips; Damon Connolly; Barbara Heller; Marc Levine; Andrew McCullough; City Council
Subject: Reject Airport Soccer/sports complex

Dear Mr. Mayor, Councilpersons and Mr. Tambornini,

The arguments for and against the Airport soccer/sports complex are extensive. Basically they amount to those who genuinely would like to enjoy sports and games and have them closer to home versus those who have analyzed the multiple and negative impacts of this huge and environmentally unsound and destructive project as it relates to the site location. The FEIR does not adequately address nor realistically can it address the impact of the the use and oversue the project would make on this fragile and important estuarian, below sea-level marsh land. Countless species will be harmed, some pushed to or over the brink of extinction. This is not an Ozzie and Harriet world any more folks -- ignoring the consequences of build-out on the airport land and the decision to do so are disingenuous.

Thank you for your consideration of the important factors related to the decision you are about to make.

Sincerely,

Joyce Clements
San Rafael, CA

Kraig Tambornini

From: Dru Parker [druparker@comcast.net]

Sent: Tuesday, July 31, 2012 2:39 PM

To: Kraig Tambornini; Damon Connolly; Gary Phillips; Barbara Heller; Marc Levine; Andrew McCullough; City Council

Subject: San Rafael Airport Recreational Facility

July 31, 2012

Gary O. Phillips, Mayor
Marc Levine, Councilmember
Damon Connolly, Councilmember
Barbara Heller, Councilmember
Andrew McCullough, Councilmember

Kraig Tambornini, Senior Planner
City of San Rafael, Community Development
PO Box 151560 San Rafael, CA 94915-1560

RE: Proposed Airport Recreational Facility

Dear Mayor and Councilmembers:

As a fifteen-year resident of San Rafael, I am very concerned about the proposal to construct a massive sports complex at the San Rafael Airport and strongly urge you to not certify its FEIR and not allow changes to zoning that would enable its construction.

Although I appreciate the need for recreational opportunities in San Rafael and Marin in general, (I am a big fan of the Pacifics and am thrilled we have a baseball team at Albert Park) and wholeheartedly support the *idea* of this type of facility, it is simply in the wrong location.

As you are aware, the State of California Department of Transportation has issued recommendations prohibiting group recreational uses, particularly those that cater to children, in the safety zones in which this proposed project lies. While I recognize that the private airport is not subject to CalTrans' land use planning guidelines, I find it quite disturbing that the City of San Rafael might disregard its warnings. At some point there will be an accident at this airport and the City's approval of this project would open us up to substantial liability. I do not believe the recreational benefit to the public is enough to offset this danger:

Organizations such as Marin Audubon and Marin Conservation League have expressed their concerns about the adequacy of the FEIR, so I don't feel the need to add to that other than to voice my concurrence with those groups' opinion that the environmental consequences (proximity to Clapper Rail, impacts on the creek and on our Santa Venetia neighbors, etc.) are inadequately addressed in this FEIR.

We definitely need a place for kids and adults to play soccer. But this facility is in the wrong place. It's nice that the city wouldn't have to pay for this private, commercial project, and lovely that the developer is promising to deliver many shades of "green" at the site, but ultimately this sort of mammoth complex should be built in a properly zoned, infill location, near adequate ground transportation and nowhere near wetlands, endangered species, airport runways

7/31/2012

and people's quiet neighborhoods.

Very truly yours,

Dru Parker
298 Oleander Drive, San Rafael, CA 94903
(415)302-6460

RE Updated List of Emails from CBD.txt

Updated List of Emails from CBD From: Jeff Miller [jmiller@biologicaldiversity.org]
Sent: Tuesday, July 31, 2012 11:58 AM
To: Kraig Tambornini
Cc: 'Judy Schriebman'; 'Joyce Clements'
Subject: RE: Updated List of Emails from CBD

Attachments: Gallinas project letters 7-31-12.xls

Kraig - here is the updated list of CBD members in California that sent you comments on the project. It is only from California residents, and is sorted by city.

2,470 comments from CA residents; it looks like 361 from Marin County residents and 131 from San Rafael residents.

- Jeff

**Jeff Miller
Conservation Advocate
Center for Biological Diversity
(415) 669-7357
351 California Street, Suite 600
San Francisco, CA 94104
www.biologicaldiversity.org**

From: Kraig Tambornini [mailto:Kraig.Tambornini@cityofsanrafael.org]
Sent: Tuesday, July 24, 2012 3:04 PM
To: Jeff Miller
Subject: Updated List of Emails from CBD

Jeff:

The City Council will hold its hearing on this project on August 6 and I would like to again request an up to date list of respondents that sent emails through CBD website regarding the Clapper Rail.

Thank you.

Kraig Tambornini, Senior Planner

City of San Rafael, Community Development

1400 Fifth Ave./PO Box 151560

San Rafael, CA 94901/94915-1560

Phone: (415) 485-3092

Fax: (415) 485-3184

kraig.tambornini@cityofsanrafael.org

RE Updated List of Emails from CBD.txt

Kraig Tambornini

From: MacDonald, Catherine [catmacdonald@sbcglobal.net]

Sent: Wednesday, August 01, 2012 7:41 AM

To: Kraig Tambornini

Cc: City Council

Subject: Airport Sports Complex Hearing

My husband and I are very opposed to building the Airport Sports Complex near the San Rafael Airport. Not only would it be built in an environmentally sensitive area, but the noise, pollution, etc, that would occur would be a great annoyance to the residents of the area. We live close enough to be potentially inconvenienced by night time lighting and traffic congestion.

Thank you for your consideration,

Catherine and Richard MacDonald

8/1/2012

10 3a-b
43
CV

Attn: Gary O. Phillips, Mayor
Marc Levine, Councilmember
Damon Connolly, Councilmember
Barbara Heller, Councilmember
Andrew McCullough, Councilmember

C/o: Kraig Tambornini, Senior Planner
City of San Rafael, Community Development
PO Box 151560
San Rafael, CA 94915-1560

via fax 485-3184

RE: Proposed Airport Soccer Complex

Dear Mayor and Councilmembers:

I am writing to express my hope that you will 1) not certify the Final EIR for the proposed San Rafael Airport Soccer Complex and 2) decline to approve zoning changes that would allow it to proceed.

I am very concerned about numerous aspects of this proposal, including:

- Neither children nor adults should play sports 160 feet from an active runway according to state safety regulations and Caltrans statements.
- The intent of the Deed of Restrictions on this property should be honored, as signatory and former Mayor Larry Mulryan has urged. The applicant/owner has already profited from the development of Autodesk, Embassy Suites and Villa Marin in exchange for keeping the airport area open and undeveloped.
- Wetland zoning allowing "low-impact" recreation is reasonable and should be maintained, but not rezoned to allow a huge 86,000 square foot commercial sports building and stadium lights.
- The amount of noise, lights and traffic would seriously impact nearby residents' ability to enjoy themselves on their own property or in surrounding open space.
- This area is currently a vital wildlife corridor and rare remnant wetlands habitat (over 90% of wetlands have been lost in the Bay Area already) that supports many animals, insects and plants (including the endangered Clapper Rail which relies solely on wetland habitats). This is not the place for a 12-hour a day giant human development.
- Serious flaws in the FEIR have been found, including a lack of mitigation for the federally protected Clapper Rail, or anything close to sufficient mitigation of noise, light and air pollution.
- Other alternatives for creating soccer sites should be explored, such as revitalizing existing sites and public/private partnerships.

I urge you not to allow this proposed soccer complex to be built. It would be devastating to the environment and have serious negative impacts on nearby communities. This area should remain such space. We have so little of these wetland areas left in the Bay Area.

Sincerely,



Signature

CARLA KOOP

Print Name

Address

17 Circle Rd., San Rafael 94903

Date

8/1/12

Kraig Tambornini

From: Arlene Davis [arlened8888@gmail.com]

Sent: Wednesday, August 01, 2012 1:28 PM

To: Kraig Tambornini; Damon Connolly; Barbara Heller; Gary Phillips; Marc Levine; Andrew McCullough; City Council

Subject: San Rafael airport/Wetlands/Soccer Complex

Members of the City Council,

I am writing to express my grave concerns regarding the private soccer stadium complex proposed for the wetlands area next to the San Rafael airport. My main concern is that this is critical habitat for the highly endangered California clapper rail. There is no doubt that the constant activity, noise, light pollution, and waste pollution will destroy the opportunity for these endangered birds to survive here. These same factors will also severely degrade the environment of the neighborhood while creating an 'accident waiting to happen' with this intense usage next to an airport runway.

The harm that would be caused by placing this huge soccer complex at this location far exceeds the benefit of providing this facility for private soccer club members and for providing profit to the developers. This is especially true given that there are several other soccer fields in the area. This developer's money would be much better spent upgrading one of those areas.

The proposed site between an airport and a wetlands is the wrong project in the wrong place.

I urge you to reject this project before the harm is done.

Respectfully,

Arlene Davis

841 Estancia Way
San Rafael, CA 94903

To: Gary O. Phillips, Mayor
Marc Levine, Councilmember
Damon Connolly, Councilmember
Barbara Heller, Councilmember
Andrew McCullough, Councilmember

City of San Rafael
P.O. Box 151560
San Rafael, CA 94915-1560

Cc: Kraig Tambornini, Senior Planner

Dear Mayor and Members of the San Rafael City Council:

I am writing as a experienced pilot who has landed at the Smith Ranch Airport as a passenger. I've heard that you plan to build a soccer facility next to the air strip, and I feel that you should reconsider.

Since 1986, almost 6000 planes have crashed in the State of California alone, for a variety of reasons. You should read

http://aircrashed.com/index/USA_CA49.shtml

carefully for details on the different kinds of accidents that can occur at any time at any airport facility, despite the experience of the pilot and the quality and age of the aircraft. Flying is, as any instructor will say, inherently dangerous. Any variation in wind and temperature presents a challenge that can overcome the most experienced pilot. **You'll note that there have been seven crashes at the San Rafael facility alone in the last twenty-five years.** Not all were due to pilot error, or the notoriously tricky winds after the wires on final approach. Mechanical problems in planes are a fact of flying life, and as I said before, no amount of experience on a pilot's part can ensure that every takeoff and touchdown will go without a hitch.

During my research I found that you are building this facility in direct violation of the standards outlined by the California Department of Transportation, Division of Aeronautics. Are you aware that that agency is empowered to sue agencies that violate those standards? See

<http://www.sdairfields.org/SunroadLawsuit/tabid/95/Default.aspx>

That San Diego case of incompatible land use led to two senior City staff resignations and myriad other consequences.

If you approve this plan, you are betting that this project will fly under the radar, so to speak. You are also betting that, if this project goes through, relatively few people will be killed by a plane careening into the facility or the parking lot.

So look at the children in soccer uniforms in front of you. Which lives are you willing to risk?

Sincerely,

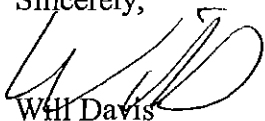

WHI Davis
1129 Santa Clara Lane
Petaluma, CA 94954

RECEIVED
AUG - 1 2012
COMMUNITY DEVELOPMENT
CITY OF SAN RAFAEL

Kraig Tambornini

From: Sherri Patterson [sherripatt@gmail.com]

Sent: Wednesday, August 01, 2012 6:22 PM

To: Kraig Tambornini; Gary Phillips; Damon Connolly; Barbara Heller; Marc Levine; Andrew McCullough; City Council

Subject: Distressed by Sports Complex location

Dear Mayor Phillips and San Rafael City Council members,

For thirty years I have been walking around McGinnis ponds and Santa Venetia marshes. Recently I realized a dream and have been able to buy a home near the JCC in Santa Venetia.

Thus I was stunned to learn of the proposed Sports Complex location right in the middle of our precious wetlands.

The United States has lost 97% of its wetlands. The remaining 3% act as an essential "sponge" against flooding and provide truly crucial habitat for wildlife, in this case particularly the Clapper Rail.

What I am stunned by is not the project per se, but the seeming short-term thinking behind it. At a time when global warming is causing planning efforts to focus on "marginal retreat", this is "maximum intrusion" into a wetland. The City or County will end up spending a fortune trying to reinforce the levees to save the sports complex. Moreover, it places kids right next to an airport!!!

I can't help but thinking about Marin IJ headlines in ten or twenty years, which I believe will read as follows:

"City spending millions to shore up levees"

"Endangered Clapper Rail near extinction in Marin"

"Near airport mishap at Sports Complex - who is to blame?"

Not trying to be overly dramatic, but I would have expected this project to be approved in the 1960's, not in the new millenium. Please, please, for the children, wildlife, and our budget reconsider the location of this project. I can think of some other locales that might work, if they have not been considered.

I really cannot express in words how strongly I feel about this issue. My heart aches. Thank you very much for your consideration.

Sherri Patterson
50 Chalda Ct.
San Rafael, CA. 94903
(415) 686-933`

--

8/2/2012

Attn: Gary O. Phillips, Mayor
Marc Levine, Councilmember
Damon Connolly, Councilmember
Barbara Heller, Councilmember
Andrew McCullough, Councilmember

PLANNING

JUL 24 2012

RECEIVED

C/o: Kraig Tambornini, Senior Planner
City of San Rafael, Community Development
PO Box 151560
San Rafael, CA 94915-1560

RE: Proposed Airport Soccer Complex

Dear Mayor and Councilmembers:

I strongly urge you to not certify the Final Environmental Impact Report for the proposed San Rafael Airport Soccer Complex and not to approve zoning changes that would allow it to go forward.

I am deeply concerned about a number of aspects of this proposal, including:

- Safety of children and adults playing sports 160 feet from an active runway (why set aside state safety regulations and the warnings of Caltrans?). Not to mention the moral and liability issues of such a step. Many planes have crashed there and it is not a question of "if" but "when" another will.
- Adult out-of-county leagues would be those most served by this pay to play, commercial project, more than local youth, as most parents in support have been led to believe.
- The public trust has been betrayed. The intent of the Deed of Restrictions on this property should of course be honored, as signatory and former Mayor Larry Mulryan has urged. The applicant/owner has already profited greatly from the development of Autodesk, Embassy Suites and Villa Marin, as was offered in exchange for keeping the airport area open and undeveloped.
- Wetland zoning allowing "low-impact" recreation is well-reasoned and should be kept in place, not rezoned to allow an 86,000 square foot commercial sports building and stadium lights.
- This would be a calamity for the quality of life for surrounding neighborhoods. The amount of noise, lights and traffic would limit peoples' ability to enjoy themselves on their own property or in surrounding open space. Prospective home buyers are already awaiting your decision.
- It is (now) a rich wildlife corridor and sensitive wetlands habitat, home to a great many types of animals, insects and plants (including one of the most Endangered Species in California, the Clapper Rail). This is not the place for a 12-hour a day, giant human development.
- Serious flaws in the FEIR have been found, including a lack of mitigation for the federally protected Clapper Rail, or anything close to sufficient mitigation of noise, light and air pollution.
- Other alternatives for creating more soccer sites should be explored, such as revitalizing existing sites and public/private partnerships.

Please, I urge you not to allow this proposed soccer complex to be built. It would be devastating to the environment and to nearby communities. This area should remain open space. Now and into the future. It is an inappropriate location for this type of development.

Sincerely,



309 VENDIA DR.

Name

Address

Date

7/22/12

Attn: Gary O. Phillips, Mayor
Marc Levine, Councilmember
Damon Connolly, Councilmember
Barbara Heller, Councilmember
Andrew McCullough, Councilmember

RECEIVED

JUL 24 2012

PLANNING

C/o: Kraig Tambornini, Senior Planner
City of San Rafael, Community Development
PO Box 151560
San Rafael, CA 94915-1560

RE: Proposed Airport Soccer Complex

Dear Mayor and Councilmembers:

I strongly urge you to not certify the Final Environmental Impact Report for the proposed San Rafael Airport Soccer Complex and not to approve zoning changes that would allow it to go forward.

I am deeply concerned about a number of aspects of this proposal, including:

- Safety of children and adults playing sports 160 feet from an active runway (why set aside state safety regulations and the warnings of Caltrans?). Not to mention the moral and liability issues of such a step. Many planes have crashed there and it is not a question of "if" but "when" another will.
- Adult out-of-county leagues would be those most served by this pay to play, commercial project, more than local youth, as most parents in support have been led to believe.
- The public trust has been betrayed. The intent of the Deed of Restrictions on this property should of course be honored, as signatory and former Mayor Larry Mulryan has urged. The applicant/owner has already profited greatly from the development of Autodesk, Embassy Suites and Villa Marin, as was offered in exchange for keeping the airport area open and undeveloped.
- Wetland zoning allowing "low-impact" recreation is well-reasoned and should be kept in place, not rezoned to allow an 86,000 square foot commercial sports building and stadium lights.
- This would be a calamity for the quality of life for surrounding neighborhoods. The amount of noise, lights and traffic would limit peoples' ability to enjoy themselves on their own property or in surrounding open space. Prospective home buyers are already awaiting your decision.
- It is (now) a rich wildlife corridor and sensitive wetlands habitat, home to a great many types of animals, insects and plants (including one of the most Endangered Species in California, the Clapper Rail). This is not the place for a 12-hour a day, giant human development.
- Serious flaws in the FEIR have been found, including a lack of mitigation for the federally protected Clapper Rail, or anything close to sufficient mitigation of noise, light and air pollution.
- Other alternatives for creating more soccer sites should be explored, such as revitalizing existing sites and public/private partnerships.

Please, I urge you not to allow this proposed soccer complex to be built. It would be devastating to the environment and to nearby communities. This area should remain open space. Now and into the future. It is an inappropriate location for this type of development.

Sincerely,

Ray Lorber

5 UPPER AVE, San Rafael

Name

Address

7-22-12

RAY LORBER

Date

Attn: Gary O. Phillips, Mayor
Marc Levine, Councilmember
Damon Connolly, Councilmember
Barbara Heller, Councilmember
Andrew McCullough, Councilmember

RECEIVED

JUL 24 2012

PLANNING

C/o: Kraig Tambornini, Senior Planner
City of San Rafael, Community Development
PO Box 151560
San Rafael, CA 94915-1560

RE: Proposed Airport Soccer Complex

Dear Mayor and Councilmembers:

I strongly urge you to not certify the Final Environmental Impact Report for the proposed San Rafael Airport Soccer Complex and not to approve zoning changes that would allow it to go forward.

I am deeply concerned about a number of aspects of this proposal, including:

- Safety of children and adults playing sports 160 feet from an active runway (why set aside state safety regulations and the warnings of Caltrans?). Not to mention the moral and liability issues of such a step. Many planes have crashed there and it is not a question of "if" but "when" another will.
- Adult out-of-county leagues would be those most served by this pay to play, commercial project, more than local youth, as most parents in support have been led to believe.
- The public trust has been betrayed. The intent of the Deed of Restrictions on this property should of course be honored, as signatory and former Mayor Larry Mulryan has urged. The applicant/owner has already profited greatly from the development of Autodesk, Embassy Suites and Villa Marin, as was offered in exchange for keeping the airport area open and undeveloped.
- Wetland zoning allowing "low-impact" recreation is well-reasoned and should be kept in place, not rezoned to allow an 86,000 square foot commercial sports building and stadium lights.
- This would be a calamity for the quality of life for surrounding neighborhoods. The amount of noise, lights and traffic would limit peoples' ability to enjoy themselves on their own property or in surrounding open space. Prospective home buyers are already awaiting your decision.
- It is (now) a rich wildlife corridor and sensitive wetlands habitat, home to a great many types of animals, insects and plants (including one of the most Endangered Species in California, the Clapper Rail). This is not the place for a 12-hour a day, giant human development.
- Serious flaws in the FEIR have been found, including a lack of mitigation for the federally protected Clapper Rail, or anything close to sufficient mitigation of noise, light and air pollution.
- Other alternatives for creating more soccer sites should be explored, such as revitalizing existing sites and public/private partnerships.

Please, I urge you not to allow this proposed soccer complex to be built. It would be devastating to the environment and to nearby communities. This area should remain open space. Now and into the future. It is an inappropriate location for this type of development.

Sincerely,

Paul Hanson

956 Del Ganado Rd

Name

Address

Date

9/22/12

San Rafael CA 94903

Attn: Gary O. Phillips, Mayor
Marc Levine, Councilmember
Damon Connolly, Councilmember
Barbara Heller, Councilmember
Andrew McCullough, Councilmember

RECEIVED

JUL 24 2012

PLANNING

C/o: Kraig Tambornini, Senior Planner
City of San Rafael, Community Development
PO Box 151560
San Rafael, CA 94915-1560

RE: Proposed Airport Soccer Complex

Dear Mayor and Councilmembers:

I strongly urge you to not certify the Final Environmental Impact Report for the proposed San Rafael Airport Soccer Complex and not to approve zoning changes that would allow it to go forward.

I am deeply concerned about a number of aspects of this proposal, including:

- Safety of children and adults playing sports 160 feet from an active runway (why set aside state safety regulations and the warnings of Caltrans?). Not to mention the moral and liability issues of such a step. Many planes have crashed there and it is not a question of "if" but "when" another will.
- Adult out-of-county leagues would be those most served by this pay to play, commercial project, more than local youth, as most parents in support have been led to believe.
- The public trust has been betrayed. The intent of the Deed of Restrictions on this property should of course be honored, as signatory and former Mayor Larry Mulryan has urged. The applicant/owner has already profited greatly from the development of Autodesk, Embassy Suites and Villa Marin, as was offered in exchange for keeping the airport area open and undeveloped.
- Wetland zoning allowing "low-impact" recreation is well-reasoned and should be kept in place, not rezoned to allow an 86,000 square foot commercial sports building and stadium lights.
- This would be a calamity for the quality of life for surrounding neighborhoods. The amount of noise, lights and traffic would limit peoples' ability to enjoy themselves on their own property or in surrounding open space. Prospective home buyers are already awaiting your decision.
- It is (now) a rich wildlife corridor and sensitive wetlands habitat, home to a great many types of animals, insects and plants (including one of the most Endangered Species in California, the Clapper Rail). This is not the place for a 12-hour a day, giant human development.
- Serious flaws in the FEIR have been found, including a lack of mitigation for the federally protected Clapper Rail, or anything close to sufficient mitigation of noise, light and air pollution.
- Other alternatives for creating more soccer sites should be explored, such as revitalizing existing sites and public/private partnerships.

Please, I urge you not to allow this proposed soccer complex to be built. It would be devastating to the environment and to nearby communities. This area should remain open space. Now and into the future. It is an inappropriate location for this type of development.

Sincerely,

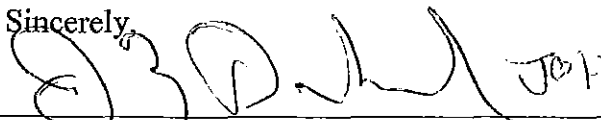
 JOHN D. HALL 454 Las Gallinas San Rafael

Name

Address

22 July 2012

Date

Attn: Gary O. Phillips, Mayor
Marc Levine, Councilmember
Damon Connolly, Councilmember
Barbara Heller, Councilmember
Andrew McCullough, Councilmember

RECEIVED

JUL 24 2012

PLANNING

C/o: Kraig Tambornini, Senior Planner
City of San Rafael, Community Development
PO Box 151560
San Rafael, CA 94915-1560

RE: Proposed Airport Soccer Complex

Dear Mayor and Councilmembers:

I strongly urge you to not certify the Final Environmental Impact Report for the proposed San Rafael Airport Soccer Complex and not to approve zoning changes that would allow it to go forward.

I am deeply concerned about a number of aspects of this proposal, including:

- Safety of children and adults playing sports 160 feet from an active runway (why set aside state safety regulations and the warnings of Caltrans?). Not to mention the moral and liability issues of such a step. Many planes have crashed there and it is not a question of "if" but "when" another will.
- Adult out-of-county leagues would be those most served by this pay to play, commercial project, more than local youth, as most parents in support have been led to believe.
- The public trust has been betrayed. The intent of the Deed of Restrictions on this property should of course be honored, as signatory and former Mayor Larry Mulryan has urged. The applicant/owner has already profited greatly from the development of Autodesk, Embassy Suites and Villa Marin, as was offered in exchange for keeping the airport area open and undeveloped.
- Wetland zoning allowing "low-impact" recreation is well-reasoned and should be kept in place, not rezoned to allow an 86,000 square foot commercial sports building and stadium lights.
- This would be a calamity for the quality of life for surrounding neighborhoods. The amount of noise, lights and traffic would limit peoples' ability to enjoy themselves on their own property or in surrounding open space. Prospective home buyers are already awaiting your decision.
- It is (now) a rich wildlife corridor and sensitive wetlands habitat, home to a great many types of animals, insects and plants (including one of the most Endangered Species in California, the Clapper Rail). This is not the place for a 12-hour a day, giant human development.
- Serious flaws in the FEIR have been found, including a lack of mitigation for the federally protected Clapper Rail, or anything close to sufficient mitigation of noise, light and air pollution.
- Other alternatives for creating more soccer sites should be explored, such as revitalizing existing sites and public/private partnerships.

Please, I urge you not to allow this proposed soccer complex to be built. It would be devastating to the environment and to nearby communities. This area should remain open space. Now and into the future. It is an inappropriate location for this type of development.

Sincerely,

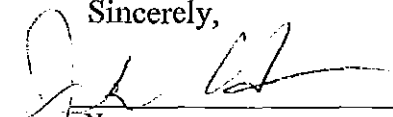
Name
7/20/12
Date

956 Del Camino San Rafael
Address
94903

Attn: Gary O. Phillips, Mayor
Marc Levine, Councilmember
Damon Connolly, Councilmember
Barbara Heller, Councilmember
Andrew McCullough, Councilmember

RECEIVED

JUL 24 2012

PLANNING

C/o: Kraig Tambornini, Senior Planner
City of San Rafael, Community Development
PO Box 151560
San Rafael, CA 94915-1560

RE: Proposed Airport Soccer Complex

Dear Mayor and Councilmembers:

I strongly urge you to not certify the Final Environmental Impact Report for the proposed San Rafael Airport Soccer Complex and not to approve zoning changes that would allow it to go forward.

I am deeply concerned about a number of aspects of this proposal, including:

- Safety of children and adults playing sports 160 feet from an active runway (why set aside state safety regulations and the warnings of Caltrans?). Not to mention the moral and liability issues of such a step. Many planes have crashed there and it is not a question of "if" but "when" another will.
- Adult out-of-county leagues would be those most served by this pay to play, commercial project, more than local youth, as most parents in support have been led to believe.
- The public trust has been betrayed. The intent of the Deed of Restrictions on this property should of course be honored, as signatory and former Mayor Larry Mulryan has urged. The applicant/owner has already profited greatly from the development of Autodesk, Embassy Suites and Villa Marin, as was offered in exchange for keeping the airport area open and undeveloped.
- Wetland zoning allowing "low-impact" recreation is well-reasoned and should be kept in place, not rezoned to allow an 86,000 square foot commercial sports building and stadium lights.
- This would be a calamity for the quality of life for surrounding neighborhoods. The amount of noise, lights and traffic would limit peoples' ability to enjoy themselves on their own property or in surrounding open space. Prospective home buyers are already awaiting your decision.
- It is (now) a rich wildlife corridor and sensitive wetlands habitat, home to a great many types of animals, insects and plants (including one of the most Endangered Species in California, the Clapper Rail). This is not the place for a 12-hour a day, giant human development.
- Serious flaws in the FEIR have been found, including a lack of mitigation for the federally protected Clapper Rail, or anything close to sufficient mitigation of noise, light and air pollution.
- Other alternatives for creating more soccer sites should be explored, such as revitalizing existing sites and public/private partnerships.

Please, I urge you not to allow this proposed soccer complex to be built. It would be devastating to the environment and to nearby communities. This area should remain open space. Now and into the future. It is an inappropriate location for this type of development.

Sincerely,

THE MACE

Name

PO BOX 4221 SAN RAFAEL

Address

CA
94915

22 JULY 12

Date

RESIDENT: KAG ROUNDTRIP

IN LATE OCT 2012

Attn: Gary O. Phillips, Mayor
Marc Levine, Councilmember
Damon Connolly, Councilmember
Barbara Heller, Councilmember
Andrew McCullough, Councilmember

RECEIVED

C/o: Kraig Tamborini, Senior Planner
City of San Rafael, Community Development
PO Box 151560
San Rafael, CA 94915-1560

JUL 24 2012

PLANNING

RE: Proposed Airport Soccer Complex

Dear Mayor and Councilmembers:

I strongly urge you to not certify the Final Environmental Impact Report for the proposed San Rafael Airport Soccer Complex and not to approve zoning changes that would allow it to go forward.

I am deeply concerned about a number of aspects of this proposal, including:

- Safety of children and adults playing sports 160 feet from an active runway (why set aside state safety regulations and the warnings of Caltrans?). Not to mention the moral and liability issues of such a step. Many planes have crashed there and it is not a question of "if" but "when" another will.
- Adult out-of-county leagues would be those most served by this pay to play, commercial project, more than local youth, as most parents in support have been led to believe.
- The public trust has been betrayed. The intent of the Deed of Restrictions on this property should of course be honored, as signatory and former Mayor Larry Mulryan has urged. The applicant/owner has already profited greatly from the development of Autodesk, Embassy Suites and Villa Marin, as was offered in exchange for keeping the airport area open and undeveloped.
- Wetland zoning allowing "low-impact" recreation is well-reasoned and should be kept in place, not rezoned to allow an 86,000 square foot commercial sports building and stadium lights.
- This would be a calamity for the quality of life for surrounding neighborhoods. The amount of noise, lights and traffic would limit peoples' ability to enjoy themselves on their own property or in surrounding open space. Prospective home buyers are already awaiting your decision.
- It is (now) a rich wildlife corridor and sensitive wetlands habitat, home to a great many types of animals, insects and plants (including one of the most Endangered Species in California, the Clapper Rail). This is not the place for a 12-hour a day, giant human development.
- Serious flaws in the FEIR have been found, including a lack of mitigation for the federally protected Clapper Rail, or anything close to sufficient mitigation of noise, light and air pollution.
- Other alternatives for creating more soccer sites should be explored, such as revitalizing existing sites and public/private partnerships.

Please, I urge you not to allow this proposed soccer complex to be built. It would be devastating to the environment and to nearby communities. This area should remain open space. Now and into the future. It is an inappropriate location for this type of development.

Sincerely,

Laureen Macpherson

Laureen Macpherson

Name

73 Rollingwood

Address

San Rafael, Ca 94901

Date

7.22.12

Attn: Gary O. Phillips, Mayor
Marc Levine, Councilmember
Damon Connolly, Councilmember
Barbara Heller, Councilmember
Andrew McCullough, Councilmember

RECEIVED

JUL 24 2012

PLANNING

C/o: Kraig Tambornini, Senior Planner
City of San Rafael, Community Development
PO Box 151560
San Rafael, CA 94915-1560

RE: Proposed Airport Soccer Complex

Dear Mayor and Councilmembers:

I strongly urge you to not certify the Final Environmental Impact Report for the proposed San Rafael Airport Soccer Complex and not to approve zoning changes that would allow it to go forward.

I am deeply concerned about a number of aspects of this proposal, including:

- Safety of children and adults playing sports 160 feet from an active runway (why set aside state safety regulations and the warnings of Caltrans?). Not to mention the moral and liability issues of such a step. Many planes have crashed there and it is not a question of "if" but "when" another will.
- Adult out-of-county leagues would be those most served by this pay to play, commercial project, more than local youth, as most parents in support have been led to believe.
- The public trust has been betrayed. The intent of the Deed of Restrictions on this property should of course be honored, as signatory and former Mayor Larry Mulryan has urged. The applicant/owner has already profited greatly from the development of Autodesk, Embassy Suites and Villa Marin, as was offered in exchange for keeping the airport area open and undeveloped.
- Wetland zoning allowing "low-impact" recreation is well-reasoned and should be kept in place, not rezoned to allow an 86,000 square foot commercial sports building and stadium lights.
- This would be a calamity for the quality of life for surrounding neighborhoods. The amount of noise, lights and traffic would limit peoples' ability to enjoy themselves on their own property or in surrounding open space. Prospective home buyers are already awaiting your decision.
- It is (now) a rich wildlife corridor and sensitive wetlands habitat, home to a great many types of animals, insects and plants (including one of the most Endangered Species in California, the Clapper Rail). This is not the place for a 12-hour a day, giant human development.
- Serious flaws in the FEIR have been found, including a lack of mitigation for the federally protected Clapper Rail, or anything close to sufficient mitigation of noise, light and air pollution.
- Other alternatives for creating more soccer sites should be explored, such as revitalizing existing sites and public/private partnerships.

Please, I urge you not to allow this proposed soccer complex to be built. It would be devastating to the environment and to nearby communities. This area should remain open space. Now and into the future. It is an inappropriate location for this type of development.

Sincerely,

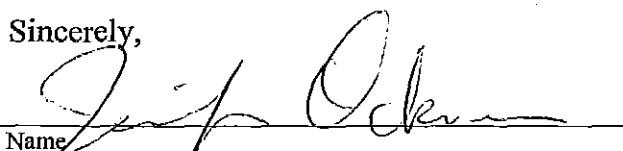
Name

455 E. Faison Dr., San Rafael, CA
Address 94903

7/22/12
Date

Attn: Gary O. Phillips, Mayor
Marc Levine, Councilmember
Damon Connolly, Councilmember
Barbara Heller, Councilmember
Andrew McCullough, Councilmember

RECEIVED

JUL 24 2012

PLANNING

C/o: Kraig Tambornini, Senior Planner
City of San Rafael, Community Development
PO Box 151560
San Rafael, CA 94915-1560

RE: Proposed Airport Soccer Complex

Dear Mayor and Councilmembers:

I strongly urge you to not certify the Final Environmental Impact Report for the proposed San Rafael Airport Soccer Complex and not to approve zoning changes that would allow it to go forward.

I am deeply concerned about a number of aspects of this proposal, including:

- Safety of children and adults playing sports 160 feet from an active runway (why set aside state safety regulations and the warnings of Caltrans?). Not to mention the moral and liability issues of such a step. Many planes have crashed there and it is not a question of "if" but "when" another will.
- Adult out-of-county leagues would be those most served by this pay to play, commercial project, more than local youth, as most parents in support have been led to believe.
- The public trust has been betrayed. The intent of the Deed of Restrictions on this property should of course be honored, as signatory and former Mayor Larry Mulryan has urged. The applicant/owner has already profited greatly from the development of Autodesk, Embassy Suites and Villa Marin, as was offered in exchange for keeping the airport area open and undeveloped.
- Wetland zoning allowing "low-impact" recreation is well-reasoned and should be kept in place, not rezoned to allow an 86,000 square foot commercial sports building and stadium lights.
- This would be a calamity for the quality of life for surrounding neighborhoods. The amount of noise, lights and traffic would limit peoples' ability to enjoy themselves on their own property or in surrounding open space. Prospective home buyers are already awaiting your decision.
- It is (now) a rich wildlife corridor and sensitive wetlands habitat, home to a great many types of animals, insects and plants (including one of the most Endangered Species in California, the Clapper Rail). This is not the place for a 12-hour a day, giant human development.
- Serious flaws in the FEIR have been found, including a lack of mitigation for the federally protected Clapper Rail, or anything close to sufficient mitigation of noise, light and air pollution.
- Other alternatives for creating more soccer sites should be explored, such as revitalizing existing sites and public/private partnerships.

Please, I urge you not to allow this proposed soccer complex to be built. It would be devastating to the environment and to nearby communities. This area should remain open space. Now and into the future. It is an inappropriate location for this type of development.

Sincerely,

Prie La-Touche

Name

250 Merrydale Rd Apt 5, San Rafael

Address

7/22/12

Date

Attn: Gary O. Phillips, Mayor
Marc Levine, Councilmember
Damon Connolly, Councilmember
Barbara Heller, Councilmember
Andrew McCullough, Councilmember

RECEIVED
JUL 24 2012
PLANNING

C/o: Kraig Tambornini, Senior Planner
City of San Rafael, Community Development
PO Box 151560
San Rafael, CA 94915-1560

RE: Proposed Airport Soccer Complex

Dear Mayor and Councilmembers:

I strongly urge you to not certify the Final Environmental Impact Report for the proposed San Rafael Airport Soccer Complex and not to approve zoning changes that would allow it to go forward.

I am deeply concerned about a number of aspects of this proposal, including:

- Safety of children and adults playing sports 160 feet from an active runway (why set aside state safety regulations and the warnings of Caltrans?). Not to mention the moral and liability issues of such a step. Many planes have crashed there and it is not a question of "if" but "when" another will.
- Adult out-of-county leagues would be those most served by this pay to play, commercial project, more than local youth, as most parents in support have been led to believe.
- The public trust has been betrayed. The intent of the Deed of Restrictions on this property should of course be honored, as signatory and former Mayor Larry Mulryan has urged. The applicant/owner has already profited greatly from the development of Autodesk, Embassy Suites and Villa Marin, as was offered in exchange for keeping the airport area open and undeveloped.
- Wetland zoning allowing "low-impact" recreation is well-reasoned and should be kept in place, not rezoned to allow an 86,000 square foot commercial sports building and stadium lights.
- This would be a calamity for the quality of life for surrounding neighborhoods. The amount of noise, lights and traffic would limit peoples' ability to enjoy themselves on their own property or in surrounding open space. Prospective home buyers are already awaiting your decision.
- It is (now) a rich wildlife corridor and sensitive wetlands habitat, home to a great many types of animals, insects and plants (including one of the most Endangered Species in California, the Clapper Rail). This is not the place for a 12-hour a day, giant human development.
- Serious flaws in the FEIR have been found, including a lack of mitigation for the federally protected Clapper Rail, or anything close to sufficient mitigation of noise, light and air pollution.
- Other alternatives for creating more soccer sites should be explored, such as revitalizing existing sites and public/private partnerships.

Please, I urge you not to allow this proposed soccer complex to be built. It would be devastating to the environment and to nearby communities. This area should remain open space. Now and into the future. It is an inappropriate location for this type of development.

Sincerely,



Name

687 Woodbine Dr San Rafael

Address

CA 94903

Date

July 22 2012

Attn: Gary O. Phillips, Mayor
Marc Levine, Councilmember
Damon Connolly, Councilmember
Barbara Heller, Councilmember
Andrew McCullough, Councilmember

RECEIVED
JUL 24 2012
PLANNING

C/o: Kraig Tambornini, Senior Planner
City of San Rafael, Community Development
PO Box 151560
San Rafael, CA 94915-1560

RE: Proposed Airport Soccer Complex

Dear Mayor and Councilmembers:

I strongly urge you to not certify the Final Environmental Impact Report for the proposed San Rafael Airport Soccer Complex and not to approve zoning changes that would allow it to go forward.

I am deeply concerned about a number of aspects of this proposal, including:

- Safety of children and adults playing sports 160 feet from an active runway (why set aside state safety regulations and the warnings of Caltrans?). Not to mention the moral and liability issues of such a step. Many planes have crashed there and it is not a question of "if" but "when" another will.
- Adult out-of-county leagues would be those most served by this pay to play, commercial project, more than local youth, as most parents in support have been led to believe.
- The public trust has been betrayed. The intent of the Deed of Restrictions on this property should of course be honored, as signatory and former Mayor Larry Mulryan has urged. The applicant/owner has already profited greatly from the development of Autodesk, Embassy Suites and Villa Marin, as was offered in exchange for keeping the airport area open and undeveloped.
- Wetland zoning allowing "low-impact" recreation is well-reasoned and should be kept in place, not rezoned to allow an 86,000 square foot commercial sports building and stadium lights.
- This would be a calamity for the quality of life for surrounding neighborhoods. The amount of noise, lights and traffic would limit peoples' ability to enjoy themselves on their own property or in surrounding open space. Prospective home buyers are already awaiting your decision.
- It is (now) a rich wildlife corridor and sensitive wetlands habitat, home to a great many types of animals, insects and plants (including one of the most Endangered Species in California, the Clapper Rail). This is not the place for a 12-hour a day, giant human development.
- Serious flaws in the FEIR have been found, including a lack of mitigation for the federally protected Clapper Rail, or anything close to sufficient mitigation of noise, light and air pollution.
- Other alternatives for creating more soccer sites should be explored, such as revitalizing existing sites and public/private partnerships.

Please, I urge you not to allow this proposed soccer complex to be built. It would be devastating to the environment and to nearby communities. This area should remain open space. Now and into the future. It is an inappropriate location for this type of development.

Sincerely,

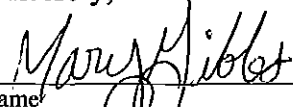
Name

7-22-12
Date

8 Cabrillo Ct., San Rafael
Address

Mary Gibbs

Attn: Gary O. Phillips, Mayor
Marc Levine, Councilmember
Damon Connolly, Councilmember
Barbara Heller, Councilmember
Andrew McCullough, Councilmember

RECEIVED
JUL 24 2012
PLANNING

C/o: Kraig Tambornini, Senior Planner
City of San Rafael, Community Development
PO Box 151560
San Rafael, CA 94915-1560

RE: Proposed Airport Soccer Complex

Dear Mayor and Councilmembers:

I strongly urge you to not certify the Final Environmental Impact Report for the proposed San Rafael Airport Soccer Complex and not to approve zoning changes that would allow it to go forward.

I am deeply concerned about a number of aspects of this proposal, including:

- Safety of children and adults playing sports 160 feet from an active runway (why set aside state safety regulations and the warnings of Caltrans?). Not to mention the moral and liability issues of such a step. Many planes have crashed there and it is not a question of "if" but "when" another will.
- Adult out-of-county leagues would be those most served by this pay to play, commercial project, more than local youth, as most parents in support have been led to believe.
- The public trust has been betrayed. The intent of the Deed of Restrictions on this property should of course be honored, as signatory and former Mayor Larry Mulryan has urged. The applicant/owner has already profited greatly from the development of Autodesk, Embassy Suites and Villa Marin, as was offered in exchange for keeping the airport area open and undeveloped.
- Wetland zoning allowing "low-impact" recreation is well-reasoned and should be kept in place, not rezoned to allow an 86,000 square foot commercial sports building and stadium lights.
- This would be a calamity for the quality of life for surrounding neighborhoods. The amount of noise, lights and traffic would limit peoples' ability to enjoy themselves on their own property or in surrounding open space. Prospective home buyers are already awaiting your decision.
- It is (now) a rich wildlife corridor and sensitive wetlands habitat, home to a great many types of animals, insects and plants (including one of the most Endangered Species in California, the Clapper Rail). This is not the place for a 12-hour a day, giant human development.
- Serious flaws in the FEIR have been found, including a lack of mitigation for the federally protected Clapper Rail, or anything close to sufficient mitigation of noise, light and air pollution.
- Other alternatives for creating more soccer sites should be explored, such as revitalizing existing sites and public/private partnerships.

Please, I urge you not to allow this proposed soccer complex to be built. It would be devastating to the environment and to nearby communities. This area should remain open space. Now and into the future. It is an inappropriate location for this type of development.

Sincerely,

Roger Barber
Name

41 Merrydale RD
Address

7/22/12
Date

San Rafael
CA, 94903
ROGER BARBER

Attn: Gary O. Phillips, Mayor
Marc Levine, Councilmember
Damon Connolly, Councilmember
Barbara Heller, Councilmember
Andrew McCullough, Councilmember

RECEIVED
JUL 24 2012
PLANNING

C/o: Kraig Tambornini, Senior Planner
City of San Rafael, Community Development
PO Box 151560
San Rafael, CA 94915-1560

RE: Proposed Airport Soccer Complex

Dear Mayor and Councilmembers:

I strongly urge you to not certify the Final Environmental Impact Report for the proposed San Rafael Airport Soccer Complex and not to approve zoning changes that would allow it to go forward.

I am deeply concerned about a number of aspects of this proposal, including:

- Safety of children and adults playing sports 160 feet from an active runway (why set aside state safety regulations and the warnings of Caltrans?). Not to mention the moral and liability issues of such a step. Many planes have crashed there and it is not a question of "if" but "when" another will.
- Adult out-of-county leagues would be those most served by this pay to play, commercial project, more than local youth, as most parents in support have been led to believe.
- The public trust has been betrayed. The intent of the Deed of Restrictions on this property should of course be honored, as signatory and former Mayor Larry Mulryan has urged. The applicant/owner has already profited greatly from the development of Autodesk, Embassy Suites and Villa Marin, as was offered in exchange for keeping the airport area open and undeveloped.
- Wetland zoning allowing "low-impact" recreation is well-reasoned and should be kept in place, not rezoned to allow an 86,000 square foot commercial sports building and stadium lights.
- This would be a calamity for the quality of life for surrounding neighborhoods. The amount of noise, lights and traffic would limit peoples' ability to enjoy themselves on their own property or in surrounding open space. Prospective home buyers are already awaiting your decision.
- It is (now) a rich wildlife corridor and sensitive wetlands habitat, home to a great many types of animals, insects and plants (including one of the most Endangered Species in California, the Clapper Rail). This is not the place for a 12-hour a day, giant human development.
- Serious flaws in the FEIR have been found, including a lack of mitigation for the federally protected Clapper Rail, or anything close to sufficient mitigation of noise, light and air pollution.
- Other alternatives for creating more soccer sites should be explored, such as revitalizing existing sites and public/private partnerships.

Please, I urge you not to allow this proposed soccer complex to be built. It would be devastating to the environment and to nearby communities. This area should remain open space. Now and into the future. It is an inappropriate location for this type of development.

Sincerely,

Linda H. Glasscock
Name

7/27/12
Date

107 PARKVIEW CIR
Address
Corte Madera, Ca 94925

Attn: Gary O. Phillips, Mayor
Marc Levine, Councilmember
Damon Connolly, Councilmember
Barbara Heller, Councilmember
Andrew McCullough, Councilmember

RECEIVED
JUL 24 2012
PLANNING

C/o: Kraig Tambornini, Senior Planner
City of San Rafael, Community Development
PO Box 151560
San Rafael, CA 94915-1560



RE: Proposed Airport Soccer Complex

Dear Mayor and Councilmembers:

I strongly urge you to not certify the Final Environmental Impact Report for the proposed San Rafael Airport Soccer Complex and not to approve zoning changes that would allow it to go forward.

I am deeply concerned about a number of aspects of this proposal, including:

- Safety of children and adults playing sports 160 feet from an active runway (why set aside state safety regulations and the warnings of Caltrans?). Not to mention the moral and liability issues of such a step. Many planes have crashed there and it is not a question of "if" but "when" another will.
- Adult out-of-county leagues would be those most served by this pay to play, commercial project, more than local youth, as most parents in support have been led to believe.
- The public trust has been betrayed. The intent of the Deed of Restrictions on this property should of course be honored, as signatory and former Mayor Larry Mulryan has urged. The applicant/owner has already profited greatly from the development of Autodesk, Embassy Suites and Villa Marin, as was offered in exchange for keeping the airport area open and undeveloped.
- Wetland zoning allowing "low-impact" recreation is well-reasoned and should be kept in place, not rezoned to allow an 86,000 square foot commercial sports building and stadium lights.
- This would be a calamity for the quality of life for surrounding neighborhoods. The amount of noise, lights and traffic would limit peoples' ability to enjoy themselves on their own property or in surrounding open space. Prospective home buyers are already awaiting your decision.
- It is (now) a rich wildlife corridor and sensitive wetlands habitat, home to a great many types of animals, insects and plants (including one of the most Endangered Species in California, the Clapper Rail). This is not the place for a 12-hour a day, giant human development.
- Serious flaws in the FEIR have been found, including a lack of mitigation for the federally protected Clapper Rail, or anything close to sufficient mitigation of noise, light and air pollution.
- Other alternatives for creating more soccer sites should be explored, such as revitalizing existing sites and public/private partnerships.

Please, I urge you not to allow this proposed soccer complex to be built. It would be devastating to the environment and to nearby communities. This area should remain open space. Now and into the future. It is an inappropriate location for this type of development.

Sincerely,

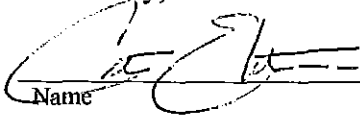
Name

312 JOYCE WAY, MILL VALLEY, 94941
Address

07/23/12
Date

Attn: Gary O. Phillips, Mayor
Marc Levine, Councilmember
Damon Connolly, Councilmember
Barbara Heller, Councilmember
Andrew McCullough, Councilmember

RECEIVED
JUL 24 2012
PLANNING

C/o: Kraig Tambornini, Senior Planner
City of San Rafael, Community Development
PO Box 151560
San Rafael, CA 94915-1560

RE: Proposed Airport Soccer Complex

Dear Mayor and Councilmembers:

I strongly urge you to not certify the Final Environmental Impact Report for the proposed San Rafael Airport Soccer Complex and not to approve zoning changes that would allow it to go forward.

I am deeply concerned about a number of aspects of this proposal, including:

- Safety of children and adults playing sports 160 feet from an active runway (why set aside state safety regulations and the warnings of Caltrans?). Not to mention the moral and liability issues of such a step. Many planes have crashed there and it is not a question of "if" but "when" another will.
- Adult out-of-county leagues would be those most served by this pay to play, commercial project, more than local youth, as most parents in support have been led to believe.
- The public trust has been betrayed. The intent of the Deed of Restrictions on this property should of course be honored, as signatory and former Mayor Larry Mulryan has urged. The applicant/owner has already profited greatly from the development of Autodesk, Embassy Suites and Villa Marin, as was offered in exchange for keeping the airport area open and undeveloped.
- Wetland zoning allowing "low-impact" recreation is well-reasoned and should be kept in place, not rezoned to allow an 86,000 square foot commercial sports building and stadium lights.
- This would be a calamity for the quality of life for surrounding neighborhoods. The amount of noise, lights and traffic would limit peoples' ability to enjoy themselves on their own property or in surrounding open space. Prospective home buyers are already awaiting your decision.
- It is (now) a rich wildlife corridor and sensitive wetlands habitat, home to a great many types of animals, insects and plants (including one of the most Endangered Species in California, the Clapper Rail). This is not the place for a 12-hour a day, giant human development.
- Serious flaws in the FEIR have been found, including a lack of mitigation for the federally protected Clapper Rail, or anything close to sufficient mitigation of noise, light and air pollution.
- Other alternatives for creating more soccer sites should be explored, such as revitalizing existing sites and public/private partnerships.

Please, I urge you not to allow this proposed soccer complex to be built. It would be devastating to the environment and to nearby communities. This area should remain open space. Now and into the future. It is an inappropriate location for this type of development.

Sincerely,

Emma Deeman
Name

312 Joyce Way, Mill Valley, CA
Address

07/22/12
Date

Attn: Gary O. Phillips, Mayor
Marc Levine, Councilmember
Damon Connolly, Councilmember
Barbara Heller, Councilmember
Andrew McCullough, Councilmember

C/o: Kraig Tambornini, Senior Planner
City of San Rafael, Community Development
PO Box 151560
San Rafael, CA 94915-1560

RECEIVED

JUL 24 2012

PLANNING

RE: Proposed Airport Soccer Complex

Dear Mayor and Councilmembers:

I strongly urge you to not certify the Final Environmental Impact Report for the proposed San Rafael Airport Soccer Complex and not to approve zoning changes that would allow it to go forward.

I am deeply concerned about a number of aspects of this proposal, including:

- Safety of children and adults playing sports 160 feet from an active runway (why set aside state safety regulations and the warnings of Caltrans?). Not to mention the moral and liability issues of such a step. Many planes have crashed there and it is not a question of "if" but "when" another will.
- Adult out-of-county leagues would be those most served by this pay to play, commercial project, more than local youth, as most parents in support have been led to believe.
- The public trust has been betrayed. The intent of the Deed of Restrictions on this property should of course be honored, as signatory and former Mayor Larry Mulryan has urged. The applicant/owner has already profited greatly from the development of Autodesk, Embassy Suites and Villa Marin, as was offered in exchange for keeping the airport area open and undeveloped.
- Wetland zoning allowing "low-impact" recreation is well-reasoned and should be kept in place, not rezoned to allow an 86,000 square foot commercial sports building and stadium lights.
- This would be a calamity for the quality of life for surrounding neighborhoods. The amount of noise, lights and traffic would limit peoples' ability to enjoy themselves on their own property or in surrounding open space. Prospective home buyers are already awaiting your decision.
- It is (now) a rich wildlife corridor and sensitive wetlands habitat, home to a great many types of animals, insects and plants (including one of the most Endangered Species in California, the Clapper Rail). This is not the place for a 12-hour a day, giant human development.
- Serious flaws in the FEIR have been found, including a lack of mitigation for the federally protected Clapper Rail, or anything close to sufficient mitigation of noise, light and air pollution.
- Other alternatives for creating more soccer sites should be explored, such as revitalizing existing sites and public/private partnerships.

Please, I urge you not to allow this proposed soccer complex to be built. It would be devastating to the environment and to nearby communities. This area should remain open space. Now and into the future. It is an inappropriate location for this type of development.

Sincerely,

Eleanor LaRocca

Name

82 Bucklelaw St Sausalito, CA
94965

Address

July 27, 2012

Date

Attn: Gary O. Phillips, Mayor
Marc Levine, Councilmember
Damon Connolly, Councilmember
Barbara Heller, Councilmember
Andrew McCullough, Councilmember

RECEIVED
JUL 24 2012
PLANNING

C/o: Kraig Tambornini, Senior Planner
City of San Rafael, Community Development
PO Box 151560
San Rafael, CA 94915-1560

RE: Proposed Airport Soccer Complex

Dear Mayor and Councilmembers:

I strongly urge you to not certify the Final Environmental Impact Report for the proposed San Rafael Airport Soccer Complex and not to approve zoning changes that would allow it to go forward.

I am deeply concerned about a number of aspects of this proposal, including:

- Safety of children and adults playing sports 160 feet from an active runway (why set aside state safety regulations and the warnings of Caltrans?). Not to mention the moral and liability issues of such a step. Many planes have crashed there and it is not a question of "if" but "when" another will.
- Adult out-of-county leagues would be those most served by this pay to play, commercial project, more than local youth, as most parents in support have been led to believe.
- The public trust has been betrayed. The intent of the Deed of Restrictions on this property should of course be honored, as signatory and former Mayor Larry Mulryan has urged. The applicant/owner has already profited greatly from the development of Autodesk, Embassy Suites and Villa Marin, as was offered in exchange for keeping the airport area open and undeveloped.
- Wetland zoning allowing "low-impact" recreation is well-reasoned and should be kept in place, not rezoned to allow an 86,000 square foot commercial sports building and stadium lights.
- This would be a calamity for the quality of life for surrounding neighborhoods. The amount of noise, lights and traffic would limit peoples' ability to enjoy themselves on their own property or in surrounding open space. Prospective home buyers are already awaiting your decision.
- It is (now) a rich wildlife corridor and sensitive wetlands habitat, home to a great many types of animals, insects and plants (including one of the most Endangered Species in California, the Clapper Rail). This is not the place for a 12-hour a day, giant human development.
- Serious flaws in the FEIR have been found, including a lack of mitigation for the federally protected Clapper Rail, or anything close to sufficient mitigation of noise, light and air pollution.
- Other alternatives for creating more soccer sites should be explored, such as revitalizing existing sites and public/private partnerships.

Please, I urge you not to allow this proposed soccer complex to be built. It would be devastating to the environment and to nearby communities. This area should remain open space. Now and into the future. It is an inappropriate location for this type of development.

Sincerely,



Name

7/22/12

Date

82 Bucklew St. Sausalito CA

Address

Attn: Gary O. Phillips, Mayor
Marc Levine, Councilmember
Damon Connolly, Councilmember
Barbara Heller, Councilmember
Andrew McCullough, Councilmember

RECEIVED
JUL 24 2012
PLANNING

C/o: Kraig Tambornini, Senior Planner
City of San Rafael, Community Development
PO Box 151560
San Rafael, CA 94915-1560

RE: Proposed Airport Soccer Complex

Dear Mayor and Councilmembers:

I strongly urge you to not certify the Final Environmental Impact Report for the proposed San Rafael Airport Soccer Complex and not to approve zoning changes that would allow it to go forward.

I am deeply concerned about a number of aspects of this proposal, including:

- Safety of children and adults playing sports 160 feet from an active runway (why set aside state safety regulations and the warnings of Caltrans?). Not to mention the moral and liability issues of such a step. Many planes have crashed there and it is not a question of "if" but "when" another will.
- Adult out-of-county leagues would be those most served by this pay to play, commercial project, more than local youth, as most parents in support have been led to believe.
- The public trust has been betrayed. The intent of the Deed of Restrictions on this property should of course be honored, as signatory and former Mayor Larry Mulryan has urged. The applicant/owner has already profited greatly from the development of Autodesk, Embassy Suites and Villa Marin, as was offered in exchange for keeping the airport area open and undeveloped.
- Wetland zoning allowing "low-impact" recreation is well-reasoned and should be kept in place, not rezoned to allow an 86,000 square foot commercial sports building and stadium lights.
- This would be a calamity for the quality of life for surrounding neighborhoods. The amount of noise, lights and traffic would limit peoples' ability to enjoy themselves on their own property or in surrounding open space. Prospective home buyers are already awaiting your decision.
- It is (now) a rich wildlife corridor and sensitive wetlands habitat, home to a great many types of animals, insects and plants (including one of the most Endangered Species in California, the Clapper Rail). This is not the place for a 12-hour a day, giant human development.
- Serious flaws in the FEIR have been found, including a lack of mitigation for the federally protected Clapper Rail, or anything close to sufficient mitigation of noise, light and air pollution.
- Other alternatives for creating more soccer sites should be explored, such as revitalizing existing sites and public/private partnerships.

Please, I urge you not to allow this proposed soccer complex to be built. It would be devastating to the environment and to nearby communities. This area should remain open space. Now and into the future. It is an inappropriate location for this type of development.

Sincerely,

Christopher Keefe

223 Curvey Lane, San Rafael, CA

Name

Address

Date

07/24/12

94965

Attn: Gary O. Phillips, Mayor
Marc Levine, Councilmember
Damon Connolly, Councilmember
Barbara Heller, Councilmember
Andrew McCullough, Councilmember

RECEIVED

C/o: Kraig Tambornini, Senior Planner
City of San Rafael, Community Development
PO Box 151560
San Rafael, CA 94915-1560

JUL 24 2012

PLANNING

RE: Proposed Airport Soccer Complex

Dear Mayor and Councilmembers:

I strongly urge you to not certify the Final Environmental Impact Report for the proposed San Rafael Airport Soccer Complex and not to approve zoning changes that would allow it to go forward.

I am deeply concerned about a number of aspects of this proposal, including:

- Safety of children and adults playing sports 160 feet from an active runway (why set aside state safety regulations and the warnings of Caltrans?). Not to mention the moral and liability issues of such a step. Many planes have crashed there and it is not a question of "if" but "when" another will.
- Adult out-of-county leagues would be those most served by this pay to play, commercial project, more than local youth, as most parents in support have been led to believe.
- The public trust has been betrayed. The intent of the Deed of Restrictions on this property should of course be honored, as signatory and former Mayor Larry Mulryan has urged. The applicant/owner has already profited greatly from the development of Autodesk, Embassy Suites and Villa Marin, as was offered in exchange for keeping the airport area open and undeveloped.
- Wetland zoning allowing "low-impact" recreation is well-reasoned and should be kept in place, not rezoned to allow an 86,000 square foot commercial sports building and stadium lights.
- This would be a calamity for the quality of life for surrounding neighborhoods. The amount of noise, lights and traffic would limit peoples' ability to enjoy themselves on their own property or in surrounding open space. Prospective home buyers are already awaiting your decision.
- It is (now) a rich wildlife corridor and sensitive wetlands habitat, home to a great many types of animals, insects and plants (including one of the most Endangered Species in California, the Clapper Rail). This is not the place for a 12-hour a day, giant human development.
- Serious flaws in the FEIR have been found, including a lack of mitigation for the federally protected Clapper Rail, or anything close to sufficient mitigation of noise, light and air pollution.
- Other alternatives for creating more soccer sites should be explored, such as revitalizing existing sites and public/private partnerships.

Please, I urge you not to allow this proposed soccer complex to be built. It would be devastating to the environment and to nearby communities. This area should remain open space. Now and into the future. It is an inappropriate location for this type of development.

Sincerely,

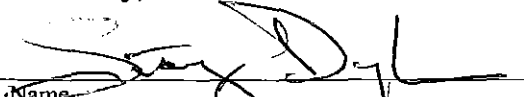
Name _____ Address 11 Berens Dr Kentfield 94904
Date 7/22/11 Stacy Doyle

Attn: Gary O. Phillips, Mayor
Marc Levine, Councilmember
Damon Connolly, Councilmember
Barbara Heller, Councilmember
Andrew McCullough, Councilmember

RECEIVED

C/o: Kraig Tambornini, Senior Planner
City of San Rafael, Community Development
PO Box 151560
San Rafael, CA 94915-1560

JUL 24 2012

PLANNING

RE: Proposed Airport Soccer Complex

Dear Mayor and Councilmembers:

I strongly urge you to not certify the Final Environmental Impact Report for the proposed San Rafael Airport Soccer Complex and not to approve zoning changes that would allow it to go forward.

I am deeply concerned about a number of aspects of this proposal, including:

- Safety of children and adults playing sports 160 feet from an active runway (why set aside state safety regulations and the warnings of Caltrans?). Not to mention the moral and liability issues of such a step. Many planes have crashed there and it is not a question of "if" but "when" another will.
- Adult out-of-county leagues would be those most served by this pay to play, commercial project, more than local youth, as most parents in support have been led to believe.
- The public trust has been betrayed. The intent of the Deed of Restrictions on this property should of course be honored, as signatory and former Mayor Larry Mulryan has urged. The applicant/owner has already profited greatly from the development of Autodesk, Embassy Suites and Villa Marin, as was offered in exchange for keeping the airport area open and undeveloped.
- Wetland zoning allowing "low-impact" recreation is well-reasoned and should be kept in place, not rezoned to allow an 86,000 square foot commercial sports building and stadium lights.
- This would be a calamity for the quality of life for surrounding neighborhoods. The amount of noise, lights and traffic would limit peoples' ability to enjoy themselves on their own property or in surrounding open space. Prospective home buyers are already awaiting your decision.
- It is (now) a rich wildlife corridor and sensitive wetlands habitat, home to a great many types of animals, insects and plants (including one of the most Endangered Species in California, the Clapper Rail). This is not the place for a 12-hour a day, giant human development.
- Serious flaws in the FEIR have been found, including a lack of mitigation for the federally protected Clapper Rail, or anything close to sufficient mitigation of noise, light and air pollution.
- Other alternatives for creating more soccer sites should be explored, such as revitalizing existing sites and public/private partnerships.

Please, I urge you not to allow this proposed soccer complex to be built. It would be devastating to the environment and to nearby communities. This area should remain open space. Now and into the future. It is an inappropriate location for this type of development.

Sincerely,

Max Ferrey
Name

161 Marlin Ave. Mill Valley, CA
Address

7/22/2012
Date

94941

Attn: Gary O. Phillips, Mayor
Marc Levine, Councilmember
Damon Connolly, Councilmember
Barbara Heller, Councilmember
Andrew McCullough, Councilmember

RECEIVED

C/o: Kraig Tambornini, Senior Planner
City of San Rafael, Community Development
PO Box 151560
San Rafael, CA 94915-1560

JUL 24 2012

PLANNING

RE: Proposed Airport Soccer Complex

Dear Mayor and Councilmembers:

I strongly urge you to not certify the Final Environmental Impact Report for the proposed San Rafael Airport Soccer Complex and not to approve zoning changes that would allow it to go forward.

I am deeply concerned about a number of aspects of this proposal, including:

- Safety of children and adults playing sports 160 feet from an active runway (why set aside state safety regulations and the warnings of Caltrans?). Not to mention the moral and liability issues of such a step. Many planes have crashed there and it is not a question of "if" but "when" another will.
- Adult out-of-county leagues would be those most served by this pay to play, commercial project, more than local youth, as most parents in support have been led to believe.
- The public trust has been betrayed. The intent of the Deed of Restrictions on this property should of course be honored, as signatory and former Mayor Larry Mulryan has urged. The applicant/owner has already profited greatly from the development of Autodesk, Embassy Suites and Villa Marin, as was offered in exchange for keeping the airport area open and undeveloped.
- Wetland zoning allowing "low-impact" recreation is well-reasoned and should be kept in place, not rezoned to allow an 86,000 square foot commercial sports building and stadium lights.
- This would be a calamity for the quality of life for surrounding neighborhoods. The amount of noise, lights and traffic would limit peoples' ability to enjoy themselves on their own property or in surrounding open space. Prospective home buyers are already awaiting your decision.
- It is (now) a rich wildlife corridor and sensitive wetlands habitat, home to a great many types of animals, insects and plants (including one of the most Endangered Species in California, the Clapper Rail). This is not the place for a 12-hour a day, giant human development.
- Serious flaws in the FEIR have been found, including a lack of mitigation for the federally protected Clapper Rail, or anything close to sufficient mitigation of noise, light and air pollution.
- Other alternatives for creating more soccer sites should be explored, such as revitalizing existing sites and public/private partnerships.

Please, I urge you not to allow this proposed soccer complex to be built. It would be devastating to the environment and to nearby communities. This area should remain open space. Now and into the future. It is an inappropriate location for this type of development.

Sincerely,

11:00 AM Stadium Lighting an issue

Name

Address

Date

7/21/12

Attn: Gary O. Phillips, Mayor
Marc Levine, Councilmember
Damon Connolly, Councilmember
Barbara Heller, Councilmember
Andrew McCullough, Councilmember

RECEIVED

JUL 24 2012

PLANNING

C/o: Kraig Tambornini, Senior Planner
City of San Rafael, Community Development
PO Box 151560
San Rafael, CA 94915-1560

RE: Proposed Airport Soccer Complex

Dear Mayor and Councilmembers:

I strongly urge you to not certify the Final Environmental Impact Report for the proposed San Rafael Airport Soccer Complex and not to approve zoning changes that would allow it to go forward.

I am deeply concerned about a number of aspects of this proposal, including:

- Safety of children and adults playing sports 160 feet from an active runway (why set aside state safety regulations and the warnings of Caltrans?). Not to mention the moral and liability issues of such a step. Many planes have crashed there and it is not a question of "if" but "when" another will.
- Adult out-of-county leagues would be those most served by this pay to play, commercial project, more than local youth, as most parents in support have been led to believe.
- The public trust has been betrayed. The intent of the Deed of Restrictions on this property should of course be honored, as signatory and former Mayor Larry Mulryan has urged. The applicant/owner has already profited greatly from the development of Autodesk, Embassy Suites and Villa Marin, as was offered in exchange for keeping the airport area open and undeveloped.
- Wetland zoning allowing "low-impact" recreation is well-reasoned and should be kept in place, not rezoned to allow an 86,000 square foot commercial sports building and stadium lights.
- This would be a calamity for the quality of life for surrounding neighborhoods. The amount of noise, lights and traffic would limit peoples' ability to enjoy themselves on their own property or in surrounding open space. Prospective home buyers are already awaiting your decision.
- It is (now) a rich wildlife corridor and sensitive wetlands habitat, home to a great many types of animals, insects and plants (including one of the most Endangered Species in California, the Clapper Rail). This is not the place for a 12-hour a day, giant human development.
- Serious flaws in the FEIR have been found, including a lack of mitigation for the federally protected Clapper Rail, or anything close to sufficient mitigation of noise, light and air pollution.
- Other alternatives for creating more soccer sites should be explored, such as revitalizing existing sites and public/private partnerships.

Please, I urge you not to allow this proposed soccer complex to be built. It would be devastating to the environment and to nearby communities. This area should remain open space. Now and into the future. It is an inappropriate location for this type of development.

Sincerely,

PATRICK DOHERTY.

Name

751

Address

32ND AVE SAN FRANCISCO

94121

22 July '12

Date

Attn: Gary O. Phillips, Mayor
Marc Levine, Councilmember
Damon Connolly, Councilmember
Barbara Heller, Councilmember
Andrew McCullough, Councilmember

RECEIVED

JUL 24 2012

PLANNING

C/o: Kraig Tambornini, Senior Planner
City of San Rafael, Community Development
PO Box 151560
San Rafael, CA 94915-1560

RE: Proposed Airport Soccer Complex

Dear Mayor and Councilmembers:

I strongly urge you to not certify the Final Environmental Impact Report for the proposed San Rafael Airport Soccer Complex and not to approve zoning changes that would allow it to go forward.

I am deeply concerned about a number of aspects of this proposal, including:

- Safety of children and adults playing sports 160 feet from an active runway (why set aside state safety regulations and the warnings of Caltrans?). Not to mention the moral and liability issues of such a step. Many planes have crashed there and it is not a question of "if" but "when" another will.
- Adult out-of-county leagues would be those most served by this pay to play, commercial project, more than local youth, as most parents in support have been led to believe.
- The public trust has been betrayed. The intent of the Deed of Restrictions on this property should of course be honored, as signatory and former Mayor Larry Mulryan has urged. The applicant/owner has already profited greatly from the development of Autodesk, Embassy Suites and Villa Marin, as was offered in exchange for keeping the airport area open and undeveloped.
- Wetland zoning allowing "low-impact" recreation is well-reasoned and should be kept in place, not rezoned to allow an 86,000 square foot commercial sports building and stadium lights.
- This would be a calamity for the quality of life for surrounding neighborhoods. The amount of noise, lights and traffic would limit peoples' ability to enjoy themselves on their own property or in surrounding open space. Prospective home buyers are already awaiting your decision.
- It is (now) a rich wildlife corridor and sensitive wetlands habitat, home to a great many types of animals, insects and plants (including one of the most Endangered Species in California, the Clapper Rail). This is not the place for a 12-hour a day, giant human development.
- Serious flaws in the FEIR have been found, including a lack of mitigation for the federally protected Clapper Rail, or anything close to sufficient mitigation of noise, light and air pollution.
- Other alternatives for creating more soccer sites should be explored, such as revitalizing existing sites and public/private partnerships.

Please, I urge you not to allow this proposed soccer complex to be built. It would be devastating to the environment and to nearby communities. This area should remain open space. Now and into the future. It is an inappropriate location for this type of development.

Sincerely,

Juan J. Alvarez-Marquez

Name

2337 Vicente St SF 94116

Address

7-22-12

Date

Attn: Gary O. Phillips, Mayor
Marc Levine, Councilmember
Damon Connolly, Councilmember
Barbara Heller, Councilmember
Andrew McCullough, Councilmember

RECEIVED

JUL 24 2012

PLANNING

C/o: Kraig Tambornini, Senior Planner
City of San Rafael, Community Development
PO Box 151560
San Rafael, CA 94915-1560

RE: Proposed Airport Soccer Complex

Dear Mayor and Councilmembers:

I strongly urge you to not certify the Final Environmental Impact Report for the proposed San Rafael Airport Soccer Complex and not to approve zoning changes that would allow it to go forward.

I am deeply concerned about a number of aspects of this proposal, including:

- Safety of children and adults playing sports 160 feet from an active runway (why set aside state safety regulations and the warnings of Caltrans?). Not to mention the moral and liability issues of such a step. Many planes have crashed there and it is not a question of "if" but "when" another will.
- Adult out-of-county leagues would be those most served by this pay to play, commercial project, more than local youth, as most parents in support have been led to believe.
- The public trust has been betrayed. The intent of the Deed of Restrictions on this property should of course be honored, as signatory and former Mayor Larry Mulryan has urged. The applicant/owner has already profited greatly from the development of Autodesk, Embassy Suites and Villa Marin, as was offered in exchange for keeping the airport area open and undeveloped.
- Wetland zoning allowing "low-impact" recreation is well-reasoned and should be kept in place, not rezoned to allow an 86,000 square foot commercial sports building and stadium lights.
- This would be a calamity for the quality of life for surrounding neighborhoods. The amount of noise, lights and traffic would limit peoples' ability to enjoy themselves on their own property or in surrounding open space. Prospective home buyers are already awaiting your decision.
- It is (now) a rich wildlife corridor and sensitive wetlands habitat, home to a great many types of animals, insects and plants (including one of the most Endangered Species in California, the Clapper Rail). This is not the place for a 12-hour a day, giant human development.
- Serious flaws in the FEIR have been found, including a lack of mitigation for the federally protected Clapper Rail, or anything close to sufficient mitigation of noise, light and air pollution.
- Other alternatives for creating more soccer sites should be explored, such as revitalizing existing sites and public/private partnerships.

Please, I urge you not to allow this proposed soccer complex to be built. It would be devastating to the environment and to nearby communities. This area should remain open space. Now and into the future. It is an inappropriate location for this type of development.

Sincerely,

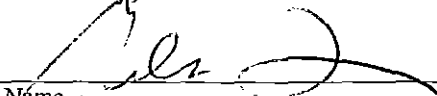

Name

Date

11595 GORRE OSMANAGE RD WAKE MAN OH

Address

4/4/82

Attn: Gary O. Phillips, Mayor
Marc Levine, Councilmember
Damon Connolly, Councilmember
Barbara Heller, Councilmember
Andrew McCullough, Councilmember

RECEIVED
JUL 24 2012
PLANNING

C/o: Kraig Tambornini, Senior Planner
City of San Rafael, Community Development
PO Box 151560
San Rafael, CA 94915-1560

RE: Proposed Airport Soccer Complex

Dear Mayor and Councilmembers:

I strongly urge you to not certify the Final Environmental Impact Report for the proposed San Rafael Airport Soccer Complex and not to approve zoning changes that would allow it to go forward.

I am deeply concerned about a number of aspects of this proposal, including:

- Safety of children and adults playing sports 160 feet from an active runway (why set aside state safety regulations and the warnings of Caltrans?). Not to mention the moral and liability issues of such a step. Many planes have crashed there and it is not a question of "if" but "when" another will.
- Adult out-of-county leagues would be those most served by this pay to play, commercial project, more than local youth, as most parents in support have been led to believe.
- The public trust has been betrayed. The intent of the Deed of Restrictions on this property should of course be honored, as signatory and former Mayor Larry Mulryan has urged. The applicant/owner has already profited greatly from the development of Autodesk, Embassy Suites and Villa Marin, as was offered in exchange for keeping the airport area open and undeveloped.
- Wetland zoning allowing "low-impact" recreation is well-reasoned and should be kept in place, not rezoned to allow an 86,000 square foot commercial sports building and stadium lights.
- This would be a calamity for the quality of life for surrounding neighborhoods. The amount of noise, lights and traffic would limit peoples' ability to enjoy themselves on their own property or in surrounding open space. Prospective home buyers are already awaiting your decision.
- It is (now) a rich wildlife corridor and sensitive wetlands habitat, home to a great many types of animals, insects and plants (including one of the most Endangered Species in California, the Clapper Rail). This is not the place for a 12-hour a day, giant human development.
- Serious flaws in the FEIR have been found, including a lack of mitigation for the federally protected Clapper Rail, or anything close to sufficient mitigation of noise, light and air pollution.
- Other alternatives for creating more soccer sites should be explored, such as revitalizing existing sites and public/private partnerships.

Please, I urge you not to allow this proposed soccer complex to be built. It would be devastating to the environment and to nearby communities. This area should remain open space. Now and into the future. It is an inappropriate location for this type of development.

Sincerely,

Jan Lyle-Tambornini
Name

160 Morgan St Oberlin D 44074
Address

21 July 2012
Date

Attn: Gary O. Phillips, Mayor
Marc Levine, Councilmember
Damon Connolly, Councilmember
Barbara Heller, Councilmember
Andrew McCullough, Councilmember

C/o: Kraig Tambornini, Senior Planner
City of San Rafael, Community Development
PO Box 151560
San Rafael, CA 94915-1560

RECEIVED
JUL 24 2012
PLANNING

RE: Proposed Airport Soccer Complex

Dear Mayor and Councilmembers:

I strongly urge you to not certify the Final Environmental Impact Report for the proposed San Rafael Airport Soccer Complex and not to approve zoning changes that would allow it to go forward.

I am deeply concerned about a number of aspects of this proposal, including:

- Safety of children and adults playing sports 160 feet from an active runway (why set aside state safety regulations and the warnings of Caltrans?). Not to mention the moral and liability issues of such a step. Many planes have crashed there and it is not a question of "if" but "when" another will.
- Adult out-of-county leagues would be those most served by this pay to play, commercial project, more than local youth, as most parents in support have been led to believe.
- The public trust has been betrayed. The intent of the Deed of Restrictions on this property should of course be honored, as signatory and former Mayor Larry Mulryan has urged. The applicant/owner has already profited greatly from the development of Autodesk, Embassy Suites and Villa Marin, as was offered in exchange for keeping the airport area open and undeveloped.
- Wetland zoning allowing "low-impact" recreation is well-reasoned and should be kept in place, not rezoned to allow an 86,000 square foot commercial sports building and stadium lights.
- This would be a calamity for the quality of life for surrounding neighborhoods. The amount of noise, lights and traffic would limit peoples' ability to enjoy themselves on their own property or in surrounding open space. Prospective home buyers are already awaiting your decision.
- It is (now) a rich wildlife corridor and sensitive wetlands habitat, home to a great many types of animals, insects and plants (including one of the most Endangered Species in California, the Clapper Rail). This is not the place for a 12-hour a day, giant human development.
- Serious flaws in the FEIR have been found, including a lack of mitigation for the federally protected Clapper Rail, or anything close to sufficient mitigation of noise, light and air pollution.
- Other alternatives for creating more soccer sites should be explored, such as revitalizing existing sites and public/private partnerships.

Please, I urge you not to allow this proposed soccer complex to be built. It would be devastating to the environment and to nearby communities. This area should remain open space. Now and into the future. It is an inappropriate location for this type of development.

Sincerely,

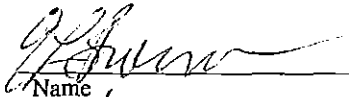

Name

248 Oakwood Street Elyria OH 44025

Address

7/21/12

Date

Attn: Gary O. Phillips, Mayor
Marc Levine, Councilmember
Damon Connolly, Councilmember
Barbara Heller, Councilmember
Andrew McCullough, Councilmember

RECEIVED

JUL 24 2012

PLANNING

C/o: Kraig Tambornini, Senior Planner
City of San Rafael, Community Development
PO Box 151560
San Rafael, CA 94915-1560

RE: Proposed Airport Soccer Complex

Dear Mayor and Councilmembers:

I strongly urge you to not certify the Final Environmental Impact Report for the proposed San Rafael Airport Soccer Complex and not to approve zoning changes that would allow it to go forward.

I am deeply concerned about a number of aspects of this proposal, including:

- Safety of children and adults playing sports 160 feet from an active runway (why set aside state safety regulations and the warnings of Caltrans?). Not to mention the moral and liability issues of such a step. Many planes have crashed there and it is not a question of "if" but "when" another will.
- Adult out-of-county leagues would be those most served by this pay to play, commercial project, more than local youth, as most parents in support have been led to believe.
- The public trust has been betrayed. The intent of the Deed of Restrictions on this property should of course be honored, as signatory and former Mayor Larry Mulryan has urged. The applicant/owner has already profited greatly from the development of Autodesk, Embassy Suites and Villa Marin, as was offered in exchange for keeping the airport area open and undeveloped.
- Wetland zoning allowing "low-impact" recreation is well-reasoned and should be kept in place, not rezoned to allow an 86,000 square foot commercial sports building and stadium lights.
- This would be a calamity for the quality of life for surrounding neighborhoods. The amount of noise, lights and traffic would limit peoples' ability to enjoy themselves on their own property or in surrounding open space. Prospective home buyers are already awaiting your decision.
- It is (now) a rich wildlife corridor and sensitive wetlands habitat, home to a great many types of animals, insects and plants (including one of the most Endangered Species in California, the Clapper Rail). This is not the place for a 12-hour a day, giant human development.
- Serious flaws in the FEIR have been found, including a lack of mitigation for the federally protected Clapper Rail, or anything close to sufficient mitigation of noise, light and air pollution.
- Other alternatives for creating more soccer sites should be explored, such as revitalizing existing sites and public/private partnerships.

Please, I urge you not to allow this proposed soccer complex to be built. It would be devastating to the environment and to nearby communities. This area should remain open space. Now and into the future. It is an inappropriate location for this type of development.

Sincerely,

Suzanne Lyke Simpson
Name

167 Harris Street
Address

11/21/00
Date

Amherst, Ohio 44001

Attn: Gary O. Phillips, Mayor
Marc Levine, Councilmember
Damon Connolly, Councilmember
Barbara Heller, Councilmember
Andrew McCullough, Councilmember

RECEIVED

C/o: Kraig Tambornini, Senior Planner
City of San Rafael, Community Development
PO Box 151560
San Rafael, CA 94915-1560

JUL 24 2012

PLANNING

RE: Proposed Airport Soccer Complex

Dear Mayor and Councilmembers:

I strongly urge you to not certify the Final Environmental Impact Report for the proposed San Rafael Airport Soccer Complex and not to approve zoning changes that would allow it to go forward.

I am deeply concerned about a number of aspects of this proposal, including:

- Safety of children and adults playing sports 160 feet from an active runway (why set aside state safety regulations and the warnings of Caltrans?). Not to mention the moral and liability issues of such a step. Many planes have crashed there and it is not a question of "if" but "when" another will.
- Adult out-of-county leagues would be those most served by this pay to play, commercial project, more than local youth, as most parents in support have been led to believe.
- The public trust has been betrayed. The intent of the Deed of Restrictions on this property should of course be honored, as signatory and former Mayor Larry Mulryan has urged. The applicant/owner has already profited greatly from the development of Autodesk, Embassy Suites and Villa Marin, as was offered in exchange for keeping the airport area open and undeveloped.
- Wetland zoning allowing "low-impact" recreation is well-reasoned and should be kept in place, not rezoned to allow an 86,000 square foot commercial sports building and stadium lights.
- This would be a calamity for the quality of life for surrounding neighborhoods. The amount of noise, lights and traffic would limit peoples' ability to enjoy themselves on their own property or in surrounding open space. Prospective home buyers are already awaiting your decision.
- It is (now) a rich wildlife corridor and sensitive wetlands habitat, home to a great many types of animals, insects and plants (including one of the most Endangered Species in California, the Clapper Rail). This is not the place for a 12-hour a day, giant human development.
- Serious flaws in the FEIR have been found, including a lack of mitigation for the federally protected Clapper Rail, or anything close to sufficient mitigation of noise, light and air pollution.
- Other alternatives for creating more soccer sites should be explored, such as revitalizing existing sites and public/private partnerships.

Please, I urge you not to allow this proposed soccer complex to be built. It would be devastating to the environment and to nearby communities. This area should remain open space. Now and into the future. It is an inappropriate location for this type of development.

Sincerely,

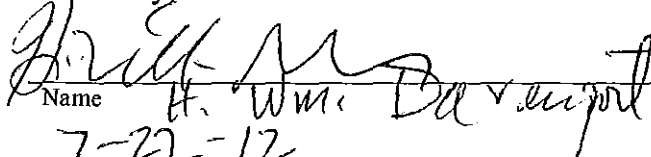
Name H. W. McDevitt

18 Hickory Bend
Macomb IL 61455
Address

Date
7-22-12

Attn: Gary O. Phillips, Mayor
Marc Levine, Councilmember
Damon Connolly, Councilmember
Barbara Heller, Councilmember
Andrew McCullough, Councilmember

JUL 25 2012

C/o: Kraig Tambornini, Senior Planner
City of San Rafael, Community Development
PO Box 151560
San Rafael, CA 94915-1560

RE: Proposed Airport Soccer Complex

Dear Mayor and Councilmembers:

I strongly urge you to not certify the Final Environmental Impact Report for the proposed San Rafael Airport Soccer Complex and not to approve zoning changes that would allow it to go forward.

I am deeply concerned about a number of aspects of this proposal, including:

- Safety of children and adults playing sports 160 feet from an active runway (why set aside state safety regulations and the warnings of Caltrans?). Not to mention the moral and liability issues of such a step. Many planes have crashed there and it is not a question of "if" but "when" another will.
- Adult out-of-county leagues would be those most served by this pay to play, commercial project, more than local youth, as most parents in support have been led to believe.
- The public trust has been betrayed. The intent of the Deed of Restrictions on this property should of course be honored, as signatory and former Mayor Larry Mulryan has urged. The applicant/owner has already profited greatly from the development of Autodesk, Embassy Suites and Villa Marin, as was offered in exchange for keeping the airport area open and undeveloped.
- Wetland zoning allowing "low-impact" recreation is well-reasoned and should be kept in place, not rezoned to allow an 86,000 square foot commercial sports building and stadium lights.
- This would be a calamity for the quality of life for surrounding neighborhoods. The amount of noise, lights and traffic would limit peoples' ability to enjoy themselves on their own property or in surrounding open space. Prospective home buyers are already awaiting your decision.
- It is (now) a rich wildlife corridor and sensitive wetlands habitat, home to a great many types of animals, insects and plants (including one of the most Endangered Species in California, the Clapper Rail). This is not the place for a 12-hour a day, giant human development.
- Serious flaws in the FEIR have been found, including a lack of mitigation for the federally protected Clapper Rail, or anything close to sufficient mitigation of noise, light and air pollution.
- Other alternatives for creating more soccer sites should be explored, such as revitalizing existing sites and public/private partnerships.

Please, I urge you not to allow this proposed soccer complex to be built. It would be devastating to the environment and to nearby communities. This area should remain open space. Now and into the future. It is an inappropriate location for this type of development.

Sincerely,

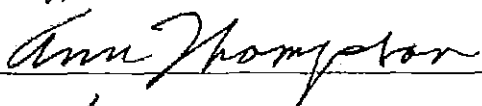
Name

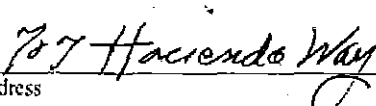
Address

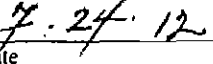
Date

Attn: Gary O. Phillips, Mayor
Marc Levine, Councilmember
Damon Connolly, Councilmember
Barbara Heller, Councilmember
Andrew McCullough, Councilmember

JUL 25 2012

C/o: Kraig Tamborini, Senior Planner
City of San Rafael, Community Development
PO Box 151560
San Rafael, CA 94915-1560

RE: Proposed Airport Soccer Complex

Dear Mayor and Councilmembers:

I strongly urge you to not certify the Final Environmental Impact Report for the proposed San Rafael Airport Soccer Complex and not to approve zoning changes that would allow it to go forward.

I am deeply concerned about a number of aspects of this proposal, including:

- Safety of children and adults playing sports 160 feet from an active runway (why set aside state safety regulations and the warnings of Caltrans?). Not to mention the moral and liability issues of such a step. Many planes have crashed there and it is not a question of "if" but "when" another will.
- Adult out-of-county leagues would be those most served by this pay to play, commercial project, more than local youth, as most parents in support have been led to believe.
- The public trust has been betrayed. The intent of the Deed of Restrictions on this property should of course be honored, as signatory and former Mayor Larry Mulryan has urged. The applicant/owner has already profited greatly from the development of Autodesk, Embassy Suites and Villa Marin, as was offered in exchange for keeping the airport area open and undeveloped.
- Wetland zoning allowing "low-impact" recreation is well-reasoned and should be kept in place, not rezoned to allow an 86,000 square foot commercial sports building and stadium lights.
- This would be a calamity for the quality of life for surrounding neighborhoods. The amount of noise, lights and traffic would limit peoples' ability to enjoy themselves on their own property or in surrounding open space. Prospective home buyers are already awaiting your decision.
- It is (now) a rich wildlife corridor and sensitive wetlands habitat, home to a great many types of animals, insects and plants (including one of the most Endangered Species in California, the Clapper Rail). This is not the place for a 12-hour a day, giant human development.
- Serious flaws in the FEIR have been found, including a lack of mitigation for the federally protected Clapper Rail, or anything close to sufficient mitigation of noise, light and air pollution.
- Other alternatives for creating more soccer sites should be explored, such as revitalizing existing sites and public/private partnerships.

Please, I urge you not to allow this proposed soccer complex to be built. It would be devastating to the environment and to nearby communities. This area should remain open space. Now and into the future. It is an inappropriate location for this type of development.

Sincerely,

J. Richard Moore

Name

7.24.12

Date

707 Hacienda Way

Address

Attn: Gary O. Phillips, Mayor
Marc Levine, Councilmember
Damon Connolly, Councilmember
Barbara Heller, Councilmember
Andrew McCullough, Councilmember

C/o: Kraig Tambornini, Senior Planner
City of San Rafael, Community Development
PO Box 151560
San Rafael, CA 94915-1560

RECEIVED

JUL 30 2012

RE: Proposed Airport Soccer Complex

PLANNING

Dear Mayor and Councilmembers:

I strongly urge you to not certify the Final Environmental Impact Report for the proposed San Rafael Airport Soccer Complex and not to approve zoning changes that would allow it to go forward.

I am deeply concerned about a number of aspects of this proposal, including:

- Safety of children and adults playing sports 160 feet from an active runway (why set aside state safety regulations and the warnings of Caltrans?). Not to mention the moral and liability issues of such a step. Planes have crashed there and it is not a question of "if" but "when" another will.
- Adult out-of-county leagues would be those most served by this pay to play, commercial project, more than local youth, as most parents in support have been led to believe.
- The public trust has been betrayed. The intent of the Deed of Restrictions on this property should of course be honored, as signatory and former Mayor Larry Mulryan has urged. The applicant/owner has already profited greatly from the development of Autodesk, Embassy Suites and Villa Marin, as was offered in exchange for keeping the airport area open and undeveloped.
- Wetland zoning allowing "low-impact" recreation is well-reasoned and should be kept in place, not rezoned to allow an 86,000 square foot commercial sports building and stadium lights.
- This would be a *calamity* for the quality of life for surrounding neighborhoods. The amount of noise, lights and traffic would seriously degrade people's ability to enjoy themselves on their own property or in surrounding open space. Prospective home buyers are already awaiting your decision.
- It is (now) a rich wildlife corridor and sensitive wetlands habitat, home to a great many types of animals, insects and plants (including one of the most Endangered Species in California, the Clapper Rail). This is not the place for a 12-hour a day, giant human development.
- Serious flaws in the FEIR have been found, including a lack of mitigation for the federally protected Clapper Rail, or anything close to sufficient mitigation of noise, light and air pollution.
- Other alternatives for creating more soccer sites should be explored, such as revitalizing existing sites and public/private partnerships.

Please, I urge you not to allow this proposed soccer complex to be built. It presents a clear safety hazard and would be devastating to the environment and to nearby communities. This area should remain open space. Now and into the future. It is an inappropriate location for this type of development.

Sincerely,

Signature
DEBORAH RODRIGUEZ
Print Name

65 Miraflores Ave. San Rafael CA 94901
Address
7/26/12
Date

Attn: Gary O. Phillips, Mayor
Marc Levine, Councilmember
Damon Connolly, Councilmember
Barbara Heller, Councilmember
Andrew McCullough, Councilmember

C/o: Kraig Tambornini, Senior Planner
City of San Rafael, Community Development
PO Box 151560
San Rafael, CA 94915-1560

RE: Proposed Airport Soccer Complex

Dear Mayor and Councilmembers:

I strongly urge you to not certify the Final Environmental Impact Report for the proposed San Rafael Airport Soccer Complex and not to approve zoning changes that would allow it to go forward.

I am deeply concerned about a number of aspects of this proposal, including:

- Safety of children and adults playing sports 160 feet from an active runway (why set aside state safety regulations and the warnings of Caltrans?). Not to mention the moral and liability issues of such a step. Planes have crashed there and it is not a question of "if" but "when" another will.
- Adult out-of-county leagues would be those most served by this pay to play, commercial project, more than local youth, as most parents in support have been led to believe.
- The public trust has been betrayed. The intent of the Deed of Restrictions on this property should of course be honored, as signatory and former Mayor Larry Mulryan has urged. The applicant/owner has already profited greatly from the development of Autodesk, Embassy Suites and Villa Marin, as was offered in exchange for keeping the airport area open and undeveloped.
- Wetland zoning allowing "low-impact" recreation is well-reasoned and should be kept in place, not rezoned to allow an 86,000 square foot commercial sports building and stadium lights.
- This would be a *calamity* for the quality of life for surrounding neighborhoods. The amount of noise, lights and traffic would seriously degrade people's ability to enjoy themselves on their own property or in surrounding open space. Prospective home buyers are already awaiting your decision.
- It is (now) a rich wildlife corridor and sensitive wetlands habitat, home to a great many types of animals, insects and plants (including one of the most Endangered Species in California, the Clapper Rail). This is not the place for a 12-hour a day, giant human development.
- Serious flaws in the FEIR have been found, including a lack of mitigation for the federally protected Clapper Rail, or anything close to sufficient mitigation of noise, light and air pollution.
- Other alternatives for creating more soccer sites should be explored, such as revitalizing existing sites and public/private partnerships.

Please, I urge you not to allow this proposed soccer complex to be built. It would be devastating to the environment and to nearby communities. This area should remain open space. Now and into the future. It is an inappropriate location for this type of development.

Sincerely,

Signature

Print Name

Address

Date

144 N. San Pedro, San Rafael
94903
July 29, 2002

Attn: Gary O. Phillips, Mayor
Marc Levine, Councilmember
Damon Connolly, Councilmember
Barbara Heller, Councilmember
Andrew McCullough, Councilmember

C/o: Kraig Tambornini, Senior Planner
City of San Rafael, Community Development
PO Box 151560
San Rafael, CA 94915-1560

RE: Proposed Airport Soccer Complex

Dear Mayor and Councilmembers:

I strongly urge you to not certify the Final Environmental Impact Report for the proposed San Rafael Airport Soccer Complex and not to approve zoning changes that would allow it to go forward.

I am deeply concerned about a number of aspects of this proposal, including:

- Safety of children and adults playing sports 160 feet from an active runway (why set aside state safety regulations and the warnings of Caltrans?). Not to mention the moral and liability issues of such a step. Planes have crashed there and it is not a question of "if" but "when" another will.
- Adult out-of-county leagues would be those most served by this pay to play, commercial project, more than local youth, as most parents in support have been led to believe.
- The public trust has been betrayed. The intent of the Deed of Restrictions on this property should of course be honored, as signatory and former Mayor Larry Mulryan has urged. The applicant/owner has already profited greatly from the development of Autodesk, Embassy Suites and Villa Marin, as was offered in exchange for keeping the airport area open and undeveloped.
- Wetland zoning allowing "low-impact" recreation is well-reasoned and should be kept in place, not rezoned to allow an 86,000 square foot commercial sports building and stadium lights.
- This would be a *calamity* for the quality of life for surrounding neighborhoods. The amount of noise, lights and traffic would seriously degrade people's ability to enjoy themselves on their own property or in surrounding open space. Prospective home buyers are already awaiting your decision.
- It is (now) a rich wildlife corridor and sensitive wetlands habitat, home to a great many types of animals, insects and plants (including one of the most Endangered Species in California, the Clapper Rail). This is not the place for a 12-hour a day, giant human development.
- Serious flaws in the FEIR have been found, including a lack of mitigation for the federally protected Clapper Rail, or anything close to sufficient mitigation of noise, light and air pollution.
- Other alternatives for creating more soccer sites should be explored, such as revitalizing existing sites and public/private partnerships.

Please, I urge you not to allow this proposed soccer complex to be built. It would be devastating to the environment and to nearby communities. This area should remain open space. Now and into the future. It is an inappropriate location for this type of development.

Sincerely,



Signature
J. Fratangelo

Print Name

304 N. San Pedro St

Address
7/29/12 SR, CA. 94903

Date

Attn: Gary O. Phillips, Mayor
Marc Levine, Councilmember
Damon Connolly, Councilmember
Barbara Heller, Councilmember
Andrew McCullough, Councilmember

C/o: Kraig Tambornini, Senior Planner
City of San Rafael, Community Development
PO Box 151560
San Rafael, CA 94915-1560

RE: Proposed Airport Soccer Complex

Dear Mayor and Councilmembers:

I strongly urge you to not certify the Final Environmental Impact Report for the proposed San Rafael Airport Soccer Complex and not to approve zoning changes that would allow it to go forward.

I am deeply concerned about a number of aspects of this proposal, including:

- Safety of children and adults playing sports 160 feet from an active runway (why set aside state safety regulations and the warnings of Caltrans?). Not to mention the moral and liability issues of such a step. Planes have crashed there and it is not a question of "if" but "when" another will.
- Adult out-of-county leagues would be those most served by this pay to play, commercial project, more than local youth, as most parents in support have been led to believe.
- The public trust has been betrayed. The intent of the Deed of Restrictions on this property should of course be honored, as signatory and former Mayor Larry Mulryan has urged. The applicant/owner has already profited greatly from the development of Autodesk, Embassy Suites and Villa Marin, as was offered in exchange for keeping the airport area open and undeveloped.
- Wetland zoning allowing "low-impact" recreation is well-reasoned and should be kept in place, not rezoned to allow an 86,000 square foot commercial sports building and stadium lights.
- This would be a *calamity* for the quality of life for surrounding neighborhoods. The amount of noise, lights and traffic would seriously degrade people's ability to enjoy themselves on their own property or in surrounding open space. Prospective home buyers are already awaiting your decision.
- It is (now) a rich wildlife corridor and sensitive wetlands habitat, home to a great many types of animals, insects and plants (including one of the most Endangered Species in California, the Clapper Rail). This is not the place for a 12-hour a day, giant human development.
- Serious flaws in the FEIR have been found, including a lack of mitigation for the federally protected Clapper Rail, or anything close to sufficient mitigation of noise, light and air pollution.
- Other alternatives for creating more soccer sites should be explored, such as revitalizing existing sites and public/private partnerships.

Please, I urge you not to allow this proposed soccer complex to be built. It would be devastating to the environment and to nearby communities. This area should remain open space. Now and into the future. It is an inappropriate location for this type of development.

Sincerely,

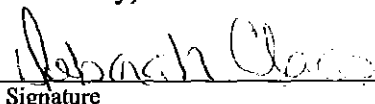

Signature

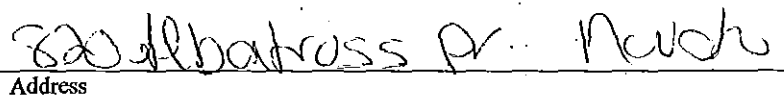

Address



Print Name

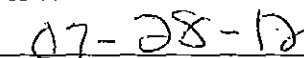

Date

Attn: Gary O. Phillips, Mayor
Marc Levine, Councilmember
Damon Connolly, Councilmember
Barbara Heller, Councilmember
Andrew McCullough, Councilmember

C/o: Kraig Tambornini, Senior Planner
City of San Rafael, Community Development
PO Box 151560
San Rafael, CA 94915-1560

RE: Proposed Airport Soccer Complex

Dear Mayor and Councilmembers:

I strongly urge you to not certify the Final Environmental Impact Report for the proposed San Rafael Airport Soccer Complex and not to approve zoning changes that would allow it to go forward.

I am deeply concerned about a number of aspects of this proposal, including:

- Safety of children and adults playing sports 160 feet from an active runway (why set aside state safety regulations and the warnings of Caltrans?). Not to mention the moral and liability issues of such a step. Planes have crashed there and it is not a question of "if" but "when" another will.
- Adult out-of-county leagues would be those most served by this pay to play, commercial project, more than local youth, as most parents in support have been led to believe.
- The public trust has been betrayed. The intent of the Deed of Restrictions on this property should of course be honored, as signatory and former Mayor Larry Mulryan has urged. The applicant/owner has already profited greatly from the development of Autodesk, Embassy Suites and Villa Marin, as was offered in exchange for keeping the airport area open and undeveloped.
- Wetland zoning allowing "low-impact" recreation is well-reasoned and should be kept in place, not rezoned to allow an 86,000 square foot commercial sports building and stadium lights.
- This would be a *calamity* for the quality of life for surrounding neighborhoods. The amount of noise, lights and traffic would seriously degrade people's ability to enjoy themselves on their own property or in surrounding open space. Prospective home buyers are already awaiting your decision.
- It is (now) a rich wildlife corridor and sensitive wetlands habitat, home to a great many types of animals, insects and plants (including one of the most Endangered Species in California, the Clapper Rail). This is not the place for a 12-hour a day, giant human development.
- Serious flaws in the FEIR have been found, including a lack of mitigation for the federally protected Clapper Rail, or anything close to sufficient mitigation of noise, light and air pollution.
- Other alternatives for creating more soccer sites should be explored, such as revitalizing existing sites and public/private partnerships.

Please, I urge you not to allow this proposed soccer complex to be built. It would be devastating to the environment and to nearby communities. This area should remain open space. Now and into the future. It is an inappropriate location for this type of development.

Sincerely,

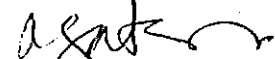

Signature

ALEXANDRA GATSIIS

Print Name

74 Madrone Park Circle

Address

7/29/12

Date

MV CA 94941

Attn: Gary O. Phillips, Mayor
Marc Levine, Councilmember
Damon Connolly, Councilmember
Barbara Heller, Councilmember
Andrew McCullough, Councilmember

C/o: Kraig Tambornini, Senior Planner
City of San Rafael, Community Development
PO Box 151560
San Rafael, CA 94915-1560

RE: Proposed Airport Soccer Complex

Dear Mayor and Councilmembers:

I strongly urge you to not certify the Final Environmental Impact Report for the proposed San Rafael Airport Soccer Complex and not to approve zoning changes that would allow it to go forward.

I am deeply concerned about a number of aspects of this proposal, including:

- Safety of children and adults playing sports 160 feet from an active runway (why set aside state safety regulations and the warnings of Caltrans?). Not to mention the moral and liability issues of such a step. Planes have crashed there and it is not a question of "if" but "when" another will.
- Adult out-of-county leagues would be those most served by this pay to play, commercial project, more than local youth, as most parents in support have been led to believe.
- The public trust has been betrayed. The intent of the Deed of Restrictions on this property should of course be honored, as signatory and former Mayor Larry Mulryan has urged. The applicant/owner has already profited greatly from the development of Autodesk, Embassy Suites and Villa Marin, as was offered in exchange for keeping the airport area open and undeveloped.
- Wetland zoning allowing "low-impact" recreation is well-reasoned and should be kept in place, not rezoned to allow an 86,000 square foot commercial sports building and stadium lights.
- This would be a *calamity* for the quality of life for surrounding neighborhoods. The amount of noise, lights and traffic would seriously degrade people's ability to enjoy themselves on their own property or in surrounding open space. Prospective home buyers are already awaiting your decision.
- It is (now) a rich wildlife corridor and sensitive wetlands habitat, home to a great many types of animals, insects and plants (including one of the most Endangered Species in California, the Clapper Rail). This is not the place for a 12-hour a day, giant human development.
- Serious flaws in the FEIR have been found, including a lack of mitigation for the federally protected Clapper Rail, or anything close to sufficient mitigation of noise, light and air pollution.
- Other alternatives for creating more soccer sites should be explored, such as revitalizing existing sites and public/private partnerships.

Please, I urge you not to allow this proposed soccer complex to be built. It would be devastating to the environment and to nearby communities. This area should remain open space. Now and into the future. It is an inappropriate location for this type of development.

Sincerely,

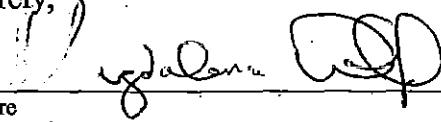

Signature
Magdalena Wolfc

Print Name

7 Bayview Street San Rafael CA

Address 94901
7/29/2012

Date

Attn: Gary O. Phillips, Mayor
Marc Levine, Councilmember
Damon Connolly, Councilmember
Barbara Heller, Councilmember
Andrew McCullough, Councilmember

C/o: Kraig Tambornini, Senior Planner
City of San Rafael, Community Development
PO Box 151560
San Rafael, CA 94915-1560

RE: Proposed Airport Soccer Complex

Dear Mayor and Councilmembers:

I strongly urge you to not certify the Final Environmental Impact Report for the proposed San Rafael Airport Soccer Complex and not to approve zoning changes that would allow it to go forward.

I am deeply concerned about a number of aspects of this proposal, including:

- Safety of children and adults playing sports 160 feet from an active runway (why set aside state safety regulations and the warnings of Caltrans?). Not to mention the moral and liability issues of such a step. Planes have crashed there and it is not a question of "if" but "when" another will.
- Adult out-of-county leagues would be those most served by this pay to play, commercial project, more than local youth, as most parents in support have been led to believe.
- The public trust has been betrayed. The intent of the Deed of Restrictions on this property should of course be honored, as signatory and former Mayor Larry Mulryan has urged. The applicant/owner has already profited greatly from the development of Autodesk, Embassy Suites and Villa Marin, as was offered in exchange for keeping the airport area open and undeveloped.
- Wetland zoning allowing "low-impact" recreation is well-reasoned and should be kept in place, not rezoned to allow an 86,000 square foot commercial sports building and stadium lights.
- This would be a *calamity* for the quality of life for surrounding neighborhoods. The amount of noise, lights and traffic would seriously degrade people's ability to enjoy themselves on their own property or in surrounding open space. Prospective home buyers are already awaiting your decision.
- It is (now) a rich wildlife corridor and sensitive wetlands habitat, home to a great many types of animals, insects and plants (including one of the most Endangered Species in California, the Clapper Rail). This is not the place for a 12-hour a day, giant human development.
- Serious flaws in the FEIR have been found, including a lack of mitigation for the federally protected Clapper Rail, or anything close to sufficient mitigation of noise, light and air pollution.
- Other alternatives for creating more soccer sites should be explored, such as revitalizing existing sites and public/private partnerships.

Please, I urge you not to allow this proposed soccer complex to be built. It would be devastating to the environment and to nearby communities. This area should remain open space. Now and into the future. It is an inappropriate location for this type of development.

Sincerely,

Signature

Print Name

Address

Date

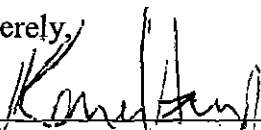
Kenneth Harwitz

358 Dobbin Ave Mill Valley CA
7-29-12

Attn: Gary O. Phillips, Mayor
Marc Levine, Councilmember
Damon Connolly, Councilmember
Barbara Heller, Councilmember
Andrew McCullough, Councilmember

At: [Illegible]

C/o: Kraig Tambornini, Senior Planner
City of San Rafael, Community Development
PO Box 151560
San Rafael, CA 94915-1560

RE: Proposed Airport Soccer Complex

Dear Mayor and Councilmembers:

I strongly urge you to not certify the Final Environmental Impact Report for the proposed San Rafael Airport Soccer Complex and not to approve zoning changes that would allow it to go forward.

I am deeply concerned about a number of aspects of this proposal, including:

- Safety of children and adults playing sports 160 feet from an active runway (why set aside state safety regulations and the warnings of Caltrans?). Not to mention the moral and liability issues of such a step. Planes have crashed there and it is not a question of "if" but "when" another will.
- Adult out-of-county leagues would be those most served by this pay to play, commercial project, more than local youth, as most parents in support have been led to believe.
- The public trust has been betrayed. The intent of the Deed of Restrictions on this property should of course be honored, as signatory and former Mayor Larry Mulryan has urged. The applicant/owner has already profited greatly from the development of Autodesk, Embassy Suites and Villa Marin, as was offered in exchange for keeping the airport area open and undeveloped.
- Wetland zoning allowing "low-impact" recreation is well-reasoned and should be kept in place, not rezoned to allow an 86,000 square foot commercial sports building and stadium lights.
- This would be a *calamity* for the quality of life for surrounding neighborhoods. The amount of noise, lights and traffic would seriously degrade people's ability to enjoy themselves on their own property or in surrounding open space. Prospective home buyers are already awaiting your decision.
- It is (now) a rich wildlife corridor and sensitive wetlands habitat, home to a great many types of animals, insects and plants (including one of the most Endangered Species in California, the Clapper Rail). This is not the place for a 12-hour a day, giant human development.
- Serious flaws in the FEIR have been found, including a lack of mitigation for the federally protected Clapper Rail, or anything close to sufficient mitigation of noise, light and air pollution.
- Other alternatives for creating more soccer sites should be explored, such as revitalizing existing sites and public/private partnerships.

Please, I urge you not to allow this proposed soccer complex to be built. It would be devastating to the environment and to nearby communities. This area should remain open space. Now and into the future. It is an inappropriate location for this type of development.

Sincerely,



Signature
Dana Shark

Print Name

23 Bolanus Dr San Rafael

Address
7/28/12

Date
CA 94944

Attn: Gary O. Phillips, Mayor
Marc Levine, Councilmember
Damon Connolly, Councilmember
Barbara Heller, Councilmember
Andrew McCullough, Councilmember

C/o: Kraig Tambornini, Senior Planner
City of San Rafael, Community Development
PO Box 151560
San Rafael, CA 94915-1560

RE: Proposed Airport Soccer Complex

Dear Mayor and Councilmembers:

I strongly urge you to not certify the Final Environmental Impact Report for the proposed San Rafael Airport Soccer Complex and not to approve zoning changes that would allow it to go forward.

I am deeply concerned about a number of aspects of this proposal, including:

- Safety of children and adults playing sports 160 feet from an active runway (why set aside state safety regulations and the warnings of Caltrans?). Not to mention the moral and liability issues of such a step. Planes have crashed there and it is not a question of "if" but "when" another will.
- Adult out-of-county leagues would be those most served by this pay to play, commercial project, more than local youth, as most parents in support have been led to believe.
- The public trust has been betrayed. The intent of the Deed of Restrictions on this property should of course be honored, as signatory and former Mayor Larry Mulryan has urged. The applicant/owner has already profited greatly from the development of Autodesk, Embassy Suites and Villa Marin, as was offered in exchange for keeping the airport area open and undeveloped.
- Wetland zoning allowing "low-impact" recreation is well-reasoned and should be kept in place, not rezoned to allow an 86,000 square foot commercial sports building and stadium lights.
- This would be a *calamity* for the quality of life for surrounding neighborhoods. The amount of noise, lights and traffic would seriously degrade people's ability to enjoy themselves on their own property or in surrounding open space. Prospective home buyers are already awaiting your decision.
- It is (now) a rich wildlife corridor and sensitive wetlands habitat, home to a great many types of animals, insects and plants (including one of the most Endangered Species in California, the Clapper Rail). This is not the place for a 12-hour a day, giant human development.
- Serious flaws in the FEIR have been found, including a lack of mitigation for the federally protected Clapper Rail, or anything close to sufficient mitigation of noise, light and air pollution.
- Other alternatives for creating more soccer sites should be explored, such as revitalizing existing sites and public/private partnerships.

Please, I urge you not to allow this proposed soccer complex to be built. It would be devastating to the environment and to nearby communities. This area should remain open space. Now and into the future. It is an inappropriate location for this type of development.

Sincerely,



Signature

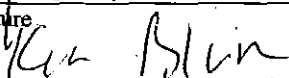

Print Name



Address



Date

Attn: Gary O. Phillips, Mayor
Marc Levine, Councilmember
Damon Connolly, Councilmember
Barbara Heller, Councilmember
Andrew McCullough, Councilmember

C/o: Kraig Tambornini, Senior Planner
City of San Rafael, Community Development
PO Box 151560
San Rafael, CA 94915-1560

RE: Proposed Airport Soccer Complex

Dear Mayor and Councilmembers:

I strongly urge you to not certify the Final Environmental Impact Report for the proposed San Rafael Airport Soccer Complex and not to approve zoning changes that would allow it to go forward.

I am deeply concerned about a number of aspects of this proposal, including:

- Safety of children and adults playing sports 160 feet from an active runway (why set aside state safety regulations and the warnings of Caltrans?). Not to mention the moral and liability issues of such a step. Planes have crashed there and it is not a question of "if" but "when" another will.
- Adult out-of-county leagues would be those most served by this pay to play, commercial project, more than local youth, as most parents in support have been led to believe.
- The public trust has been betrayed. The intent of the Deed of Restrictions on this property should of course be honored, as signatory and former Mayor Larry Mulryan has urged. The applicant/owner has already profited greatly from the development of Autodesk, Embassy Suites and Villa Marin, as was offered in exchange for keeping the airport area open and undeveloped.
- Wetland zoning allowing "low-impact" recreation is well-reasoned and should be kept in place, not rezoned to allow an 86,000 square foot commercial sports building and stadium lights.
- This would be a *calamity* for the quality of life for surrounding neighborhoods. The amount of noise, lights and traffic would seriously degrade people's ability to enjoy themselves on their own property or in surrounding open space. Prospective home buyers are already awaiting your decision.
- It is (now) a rich wildlife corridor and sensitive wetlands habitat, home to a great many types of animals, insects and plants (including one of the most Endangered Species in California, the Clapper Rail). This is not the place for a 12-hour a day, giant human development.
- Serious flaws in the FEIR have been found, including a lack of mitigation for the federally protected Clapper Rail, or anything close to sufficient mitigation of noise, light and air pollution.
- Other alternatives for creating more soccer sites should be explored, such as revitalizing existing sites and public/private partnerships.

Please, I urge you not to allow this proposed soccer complex to be built. It would be devastating to the environment and to nearby communities. This area should remain open space. Now and into the future. It is an inappropriate location for this type of development.

Sincerely,



Signature

PHILIP DARNLEY

Print Name

49 Marin Ave, MV CA 94941

Address

7/28/12

Date

Attn: Gary O. Phillips, Mayor
Marc Levine, Councilmember
Damon Connolly, Councilmember
Barbara Heller, Councilmember
Andrew McCullough, Councilmember

C/o: Kraig Tambornini, Senior Planner
City of San Rafael, Community Development
PO Box 151560
San Rafael, CA 94915-1560

RE: Proposed Airport Soccer Complex

Dear Mayor and Councilmembers:

I strongly urge you to not certify the Final Environmental Impact Report for the proposed San Rafael Airport Soccer Complex and not to approve zoning changes that would allow it to go forward.

I am deeply concerned about a number of aspects of this proposal, including:

- Safety of children and adults playing sports 160 feet from an active runway (why set aside state safety regulations and the warnings of Caltrans?). Not to mention the moral and liability issues of such a step. Planes have crashed there and it is not a question of "if" but "when" another will.
- Adult out-of-county leagues would be those most served by this pay to play, commercial project, more than local youth, as most parents in support have been led to believe.
- The public trust has been betrayed. The intent of the Deed of Restrictions on this property should of course be honored, as signatory and former Mayor Larry Mulryan has urged. The applicant/owner has already profited greatly from the development of Autodesk, Embassy Suites and Villa Marin, as was offered in exchange for keeping the airport area open and undeveloped.
- Wetland zoning allowing "low-impact" recreation is well-reasoned and should be kept in place, not rezoned to allow an 86,000 square foot commercial sports building and stadium lights.
- This would be a *calamity* for the quality of life for surrounding neighborhoods. The amount of noise, lights and traffic would seriously degrade people's ability to enjoy themselves on their own property or in surrounding open space. Prospective home buyers are already awaiting your decision.
- It is (now) a rich wildlife corridor and sensitive wetlands habitat, home to a great many types of animals, insects and plants (including one of the most Endangered Species in California, the Clapper Rail). This is not the place for a 12-hour a day, giant human development.
- Serious flaws in the FEIR have been found, including a lack of mitigation for the federally protected Clapper Rail, or anything close to sufficient mitigation of noise, light and air pollution.
- Other alternatives for creating more soccer sites should be explored, such as revitalizing existing sites and public/private partnerships.

Please, I urge you not to allow this proposed soccer complex to be built. It would be devastating to the environment and to nearby communities. This area should remain open space. Now and into the future. It is an inappropriate location for this type of development.

Sincerely,



Signature

Heather Moore

Print Name

631 Vendola Dr San Rafael

Address

7/29/12

Date

Attn: Gary O. Phillips, Mayor
Marc Levine, Councilmember
Damon Connolly, Councilmember
Barbara Heller, Councilmember
Andrew McCullough, Councilmember

C/o: Kraig Tambornini, Senior Planner
City of San Rafael, Community Development
PO Box 151560
San Rafael, CA 94915-1560

RE: Proposed Airport Soccer Complex

Dear Mayor and Councilmembers:

I strongly urge you to not certify the Final Environmental Impact Report for the proposed San Rafael Airport Soccer Complex and not to approve zoning changes that would allow it to go forward.

I am deeply concerned about a number of aspects of this proposal, including:

- Safety of children and adults playing sports 160 feet from an active runway (why set aside state safety regulations and the warnings of Caltrans?). Not to mention the moral and liability issues of such a step. Planes have crashed there and it is not a question of "if" but "when" another will.
- Adult out-of-county leagues would be those most served by this pay to play, commercial project, more than local youth, as most parents in support have been led to believe.
- The public trust has been betrayed. The intent of the Deed of Restrictions on this property should of course be honored, as signatory and former Mayor Larry Mulryan has urged. The applicant/owner has already profited greatly from the development of Autodesk, Embassy Suites and Villa Marin, as was offered in exchange for keeping the airport area open and undeveloped.
- Wetland zoning allowing "low-impact" recreation is well-reasoned and should be kept in place, not rezoned to allow an 86,000 square foot commercial sports building and stadium lights.
- This would be a *calamity* for the quality of life for surrounding neighborhoods. The amount of noise, lights and traffic would seriously degrade people's ability to enjoy themselves on their own property or in surrounding open space. Prospective home buyers are already awaiting your decision.
- It is (now) a rich wildlife corridor and sensitive wetlands habitat, home to a great many types of animals, insects and plants (including one of the most Endangered Species in California, the Clapper Rail). This is not the place for a 12-hour a day, giant human development.
- Serious flaws in the FEIR have been found, including a lack of mitigation for the federally protected Clapper Rail, or anything close to sufficient mitigation of noise, light and air pollution.
- Other alternatives for creating more soccer sites should be explored, such as revitalizing existing sites and public/private partnerships.

Please, I urge you not to allow this proposed soccer complex to be built. It would be devastating to the environment and to nearby communities. This area should remain open space. Now and into the future. It is an inappropriate location for this type of development.

Sincerely,

Amy Hall

Signature

Amy Hall

Print Name

71 Vista Marin Dr. San Rafael

Address

7/29/12

Date

Attn: Gary O. Phillips, Mayor
Marc Levine, Councilmember
Damon Connolly, Councilmember
Barbara Heller, Councilmember
Andrew McCullough, Councilmember

C/o: Kraig Tambornini, Senior Planner
City of San Rafael, Community Development
PO Box 151560
San Rafael, CA 94915-1560

RE: Proposed Airport Soccer Complex

Dear Mayor and Councilmembers:

I strongly urge you to not certify the Final Environmental Impact Report for the proposed San Rafael Airport Soccer Complex and not to approve zoning changes that would allow it to go forward.

I am deeply concerned about a number of aspects of this proposal, including:

- Safety of children and adults playing sports 160 feet from an active runway (why set aside state safety regulations and the warnings of Caltrans?). Not to mention the moral and liability issues of such a step. Planes have crashed there and it is not a question of "if" but "when" another will.
- Adult out-of-county leagues would be those most served by this pay to play, commercial project, more than local youth, as most parents in support have been led to believe.
- The public trust has been betrayed. The intent of the Deed of Restrictions on this property should of course be honored, as signatory and former Mayor Larry Mulryan has urged. The applicant/owner has already profited greatly from the development of Autodesk, Embassy Suites and Villa Marin, as was offered in exchange for keeping the airport area open and undeveloped.
- Wetland zoning allowing "low-impact" recreation is well-reasoned and should be kept in place, not rezoned to allow an 86,000 square foot commercial sports building and stadium lights.
- This would be a *calamity* for the quality of life for surrounding neighborhoods. The amount of noise, lights and traffic would seriously degrade people's ability to enjoy themselves on their own property or in surrounding open space. Prospective home buyers are already awaiting your decision.
- It is (now) a rich wildlife corridor and sensitive wetlands habitat, home to a great many types of animals, insects and plants (including one of the most Endangered Species in California, the Clapper Rail). This is not the place for a 12-hour a day, giant human development.
- Serious flaws in the FEIR have been found, including a lack of mitigation for the federally protected Clapper Rail, or anything close to sufficient mitigation of noise, light and air pollution.
- Other alternatives for creating more soccer sites should be explored, such as revitalizing existing sites and public/private partnerships.

Please, I urge you not to allow this proposed soccer complex to be built. It would be devastating to the environment and to nearby communities. This area should remain open space. Now and into the future. It is an inappropriate location for this type of development.

Sincerely,



Signature
RICHARD HALL

Print Name

71 VISTA MARIN DR

Address
7/29/2012

Date

Attn: Gary O. Phillips, Mayor
Marc Levine, Councilmember
Damon Connolly, Councilmember
Barbara Heller, Councilmember
Andrew McCullough, Councilmember

C/o: Kraig Tambornini, Senior Planner
City of San Rafael, Community Development
PO Box 151560
San Rafael, CA 94915-1560

RE: Proposed Airport Soccer Complex

Dear Mayor and Councilmembers:

I strongly urge you to not certify the Final Environmental Impact Report for the proposed San Rafael Airport Soccer Complex and not to approve zoning changes that would allow it to go forward.

I am deeply concerned about a number of aspects of this proposal, including:

- Safety of children and adults playing sports 160 feet from an active runway (why set aside state safety regulations and the warnings of Caltrans?). Not to mention the moral and liability issues of such a step. Planes have crashed there and it is not a question of "if" but "when" another will.
- Adult out-of-county leagues would be those most served by this pay to play, commercial project, more than local youth, as most parents in support have been led to believe.
- The public trust has been betrayed. The intent of the Deed of Restrictions on this property should of course be honored, as signatory and former Mayor Larry Mulryan has urged. The applicant/owner has already profited greatly from the development of Autodesk, Embassy Suites and Villa Marin, as was offered in exchange for keeping the airport area open and undeveloped.
- Wetland zoning allowing "low-impact" recreation is well-reasoned and should be kept in place, not rezoned to allow an 86,000 square foot commercial sports building and stadium lights.
- This would be a *calamity* for the quality of life for surrounding neighborhoods. The amount of noise, lights and traffic would seriously degrade people's ability to enjoy themselves on their own property or in surrounding open space. Prospective home buyers are already awaiting your decision.
- It is (now) a rich wildlife corridor and sensitive wetlands habitat, home to a great many types of animals, insects and plants (including one of the most Endangered Species in California, the Clapper Rail). This is not the place for a 12-hour a day, giant human development.
- Serious flaws in the FEIR have been found, including a lack of mitigation for the federally protected Clapper Rail, or anything close to sufficient mitigation of noise, light and air pollution.
- Other alternatives for creating more soccer sites should be explored, such as revitalizing existing sites and public/private partnerships.

Please, I urge you not to allow this proposed soccer complex to be built. It would be devastating to the environment and to nearby communities. This area should remain open space. Now and into the future. It is an inappropriate location for this type of development.

Sincerely,

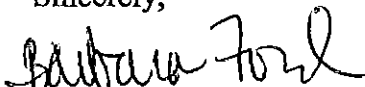

Signature

Print Name

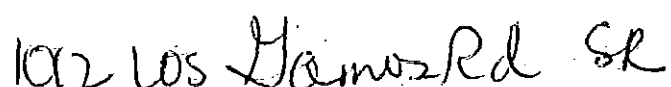

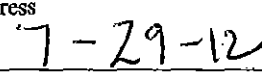
Address

Date

Attn: Gary O. Phillips, Mayor
Marc Levine, Councilmember
Damon Connolly, Councilmember
Barbara Heller, Councilmember
Andrew McCullough, Councilmember

C/o: Kraig Tambornini, Senior Planner
City of San Rafael, Community Development
PO Box 151560
San Rafael, CA 94915-1560

RE: Proposed Airport Soccer Complex

Dear Mayor and Councilmembers:

I strongly urge you to not certify the Final Environmental Impact Report for the proposed San Rafael Airport Soccer Complex and not to approve zoning changes that would allow it to go forward.

I am deeply concerned about a number of aspects of this proposal, including:

- Safety of children and adults playing sports 160 feet from an active runway (why set aside state safety regulations and the warnings of Caltrans?). Not to mention the moral and liability issues of such a step. Planes have crashed there and it is not a question of "if" but "when" another will.
- Adult out-of-county leagues would be those most served by this pay to play, commercial project, more than local youth, as most parents in support have been led to believe.
- The public trust has been betrayed. The intent of the Deed of Restrictions on this property should of course be honored, as signatory and former Mayor Larry Mulryan has urged. The applicant/owner has already profited greatly from the development of Autodesk, Embassy Suites and Villa Marin, as was offered in exchange for keeping the airport area open and undeveloped.
- Wetland zoning allowing "low-impact" recreation is well-reasoned and should be kept in place, not rezoned to allow an 86,000 square foot commercial sports building and stadium lights.
- This would be a *calamity* for the quality of life for surrounding neighborhoods. The amount of noise, lights and traffic would seriously degrade people's ability to enjoy themselves on their own property or in surrounding open space. Prospective home buyers are already awaiting your decision.
- It is (now) a rich wildlife corridor and sensitive wetlands habitat, home to a great many types of animals, insects and plants (including one of the most Endangered Species in California, the Clapper Rail). This is not the place for a 12-hour a day, giant human development.
- Serious flaws in the FEIR have been found, including a lack of mitigation for the federally protected Clapper Rail, or anything close to sufficient mitigation of noise, light and air pollution.
- Other alternatives for creating more soccer sites should be explored, such as revitalizing existing sites and public/private partnerships.

Please, I urge you not to allow this proposed soccer complex to be built. It would be devastating to the environment and to nearby communities. This area should remain open space. Now and into the future. It is an inappropriate location for this type of development.

Sincerely,

Robert Hill

Signature

ROBERT HILL

Print Name

4 PALAZZI CT

Address

7/29/12

Date

Attn: Gary O. Phillips, Mayor
Marc Levine, Councilmember
Damon Connolly, Councilmember
Barbara Heller, Councilmember
Andrew McCullough, Councilmember

C/o: Kraig Tambornini, Senior Planner
City of San Rafael, Community Development
PO Box 151560
San Rafael, CA 94915-1560

RE: Proposed Airport Soccer Complex

Dear Mayor and Councilmembers:

I strongly urge you to not certify the Final Environmental Impact Report for the proposed San Rafael Airport Soccer Complex and not to approve zoning changes that would allow it to go forward.

I am deeply concerned about a number of aspects of this proposal, including:

- Safety of children and adults playing sports 160 feet from an active runway (why set aside state safety regulations and the warnings of Caltrans?). Not to mention the moral and liability issues of such a step. Planes have crashed there and it is not a question of "if" but "when" another will.
- Adult out-of-county leagues would be those most served by this pay to play, commercial project, more than local youth, as most parents in support have been led to believe.
- The public trust has been betrayed. The intent of the Deed of Restrictions on this property should of course be honored, as signatory and former Mayor Larry Mulryan has urged. The applicant/owner has already profited greatly from the development of Autodesk, Embassy Suites and Villa Marin, as was offered in exchange for keeping the airport area open and undeveloped.
- Wetland zoning allowing "low-impact" recreation is well-reasoned and should be kept in place, not rezoned to allow an 86,000 square foot commercial sports building and stadium lights.
- This would be a *calamity* for the quality of life for surrounding neighborhoods. The amount of noise, lights and traffic would seriously degrade people's ability to enjoy themselves on their own property or in surrounding open space. Prospective home buyers are already awaiting your decision.
- It is (now) a rich wildlife corridor and sensitive wetlands habitat, home to a great many types of animals, insects and plants (including one of the most Endangered Species in California, the Clapper Rail). This is not the place for a 12-hour a day, giant human development.
- Serious flaws in the FEIR have been found, including a lack of mitigation for the federally protected Clapper Rail, or anything close to sufficient mitigation of noise, light and air pollution.
- Other alternatives for creating more soccer sites should be explored, such as revitalizing existing sites and public/private partnerships.

Please, I urge you not to allow this proposed soccer complex to be built. It would be devastating to the environment and to nearby communities. This area should remain open space. Now and into the future. It is an inappropriate location for this type of development.

Sincerely,



Signature

MYRTO ASHE

Print Name

15 Pine Hill Ct San Rafael

Address

7/29/12

Date

Attn: Gary O. Phillips, Mayor
Marc Levine, Councilmember
Damon Connolly, Councilmember
Barbara Heller, Councilmember
Andrew McCullough, Councilmember

C/o: Kraig Tambornini, Senior Planner
City of San Rafael, Community Development
PO Box 151560
San Rafael, CA 94915-1560

RE: Proposed Airport Soccer Complex

Dear Mayor and Councilmembers:

I strongly urge you to not certify the Final Environmental Impact Report for the proposed San Rafael Airport Soccer Complex and not to approve zoning changes that would allow it to go forward.

I am deeply concerned about a number of aspects of this proposal, including:

- Safety of children and adults playing sports 160 feet from an active runway (why set aside state safety regulations and the warnings of Caltrans?). Not to mention the moral and liability issues of such a step. Planes have crashed there and it is not a question of "if" but "when" another will.
- Adult out-of-county leagues would be those most served by this pay to play, commercial project, more than local youth, as most parents in support have been led to believe.
- The public trust has been betrayed. The intent of the Deed of Restrictions on this property should of course be honored, as signatory and former Mayor Larry Mulryan has urged. The applicant/owner has already profited greatly from the development of Autodesk, Embassy Suites and Villa Marin, as was offered in exchange for keeping the airport area open and undeveloped.
- Wetland zoning allowing "low-impact" recreation is well-reasoned and should be kept in place, not rezoned to allow an 86,000 square foot commercial sports building and stadium lights.
- This would be a *calamity* for the quality of life for surrounding neighborhoods. The amount of noise, lights and traffic would seriously degrade people's ability to enjoy themselves on their own property or in surrounding open space. Prospective home buyers are already awaiting your decision.
- It is (now) a rich wildlife corridor and sensitive wetlands habitat, home to a great many types of animals, insects and plants (including one of the most Endangered Species in California, the Clapper Rail). This is not the place for a 12-hour a day, giant human development.
- Serious flaws in the FEIR have been found, including a lack of mitigation for the federally protected Clapper Rail, or anything close to sufficient mitigation of noise, light and air pollution.
- Other alternatives for creating more soccer sites should be explored, such as revitalizing existing sites and public/private partnerships.

Please, I urge you not to allow this proposed soccer complex to be built. It would be devastating to the environment and to nearby communities. This area should remain open space. Now and into the future. It is an inappropriate location for this type of development.

Sincerely,

Louise Miller

Signature

Louise Miller

Print Name

6 Beary Ave, Kentfield

Address

7/28/12

Date

CA

Attn: Gary O. Phillips, Mayor
Marc Levine, Councilmember
Damon Connolly, Councilmember
Barbara Heller, Councilmember
Andrew McCullough, Councilmember

City of San Rafael, California
City Council
City Administration Center
1000 San Francisco Avenue
San Rafael, CA 94901
Phone: (415) 456-1000
Fax: (415) 456-1001
www.cityofsanrafael.org

C/o: Kraig Tambornini, Senior Planner
City of San Rafael, Community Development
PO Box 151560
San Rafael, CA 94915-1560

RE: Proposed Airport Soccer Complex

Dear Mayor and Councilmembers:

I strongly urge you to not certify the Final Environmental Impact Report for the proposed San Rafael Airport Soccer Complex and not to approve zoning changes that would allow it to go forward.

I am deeply concerned about a number of aspects of this proposal, including:

- Safety of children and adults playing sports 160 feet from an active runway (why set aside state safety regulations and the warnings of Caltrans?). Not to mention the moral and liability issues of such a step. Planes have crashed there and it is not a question of "if" but "when" another will.
- Adult out-of-county leagues would be those most served by this pay to play, commercial project, more than local youth, as most parents in support have been led to believe.
- The public trust has been betrayed. The intent of the Deed of Restrictions on this property should of course be honored, as signatory and former Mayor Larry Mulryan has urged. The applicant/owner has already profited greatly from the development of Autodesk, Embassy Suites and Villa Marin, as was offered in exchange for keeping the airport area open and undeveloped.
- Wetland zoning allowing "low-impact" recreation is well-reasoned and should be kept in place, not rezoned to allow an 86,000 square foot commercial sports building and stadium lights.
- This would be a *calamity* for the quality of life for surrounding neighborhoods. The amount of noise, lights and traffic would seriously degrade people's ability to enjoy themselves on their own property or in surrounding open space. Prospective home buyers are already awaiting your decision.
- It is (now) a rich wildlife corridor and sensitive wetlands habitat, home to a great many types of animals, insects and plants (including one of the most Endangered Species in California, the Clapper Rail). This is not the place for a 12-hour a day, giant human development.
- Serious flaws in the FEIR have been found, including a lack of mitigation for the federally protected Clapper Rail, or anything close to sufficient mitigation of noise, light and air pollution.
- Other alternatives for creating more soccer sites should be explored, such as revitalizing existing sites and public/private partnerships.

Please, I urge you not to allow this proposed soccer complex to be built. It would be devastating to the environment and to nearby communities. This area should remain open space. Now and into the future. It is an inappropriate location for this type of development.

Sincerely,

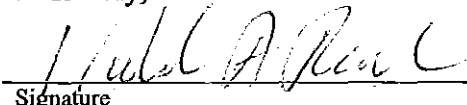

Richard Redmond
Print Name

47 G'BRAE BOARDWALK

7/29/12
Date

Attn: Gary C. Phillips, Mayor
Marc Levine, Councilmember
Damon Connolly, Councilmember
Barbara Heller, Councilmember
Andrew McCullough, Councilmember

Gary O. J
Marc L
Damon C
Barbara H
Andrew M

C/o: Kraig Tambornini, Senior Planner
City of San Rafael, Community Development
PO Box 151560
San Rafael, CA 94915-1560

RE: Proposed Airport Soccer Complex

Dear Mayor and Councilmembers:

I strongly urge you to not certify the Final Environmental Impact Report for the proposed San Rafael Airport Soccer Complex and not to approve zoning changes that would allow it to go forward.

I am deeply concerned about a number of aspects of this proposal, including:

- Safety of children and adults playing sports 160 feet from an active runway (why set aside state safety regulations and the warnings of Caltrans?). Not to mention the moral and liability issues of such a step. Planes have crashed there and it is not a question of "if" but "when" another will.
- Adult out-of-county leagues would be those most served by this pay to play, commercial project, more than local youth, as most parents in support have been led to believe.
- The public trust has been betrayed. The intent of the Deed of Restrictions on this property should of course be honored, as signatory and former Mayor Larry Mulryan has urged. The applicant/owner has already profited greatly from the development of Autodesk, Embassy Suites and Villa Marin, as was offered in exchange for keeping the airport area open and undeveloped.
- Wetland zoning allowing "low-impact" recreation is well-reasoned and should be kept in place, not rezoned to allow an 86,000 square foot commercial sports building and stadium lights.
- This would be a *calamity* for the quality of life for surrounding neighborhoods. The amount of noise, lights and traffic would seriously degrade people's ability to enjoy themselves on their own property or in surrounding open space. Prospective home buyers are already awaiting your decision.
- It is (now) a rich wildlife corridor and sensitive wetlands habitat, home to a great many types of animals, insects and plants (including one of the most Endangered Species in California, the Clapper Rail). This is not the place for a 12-hour a day, giant human development.
- Serious flaws in the FEIR have been found, including a lack of mitigation for the federally protected Clapper Rail, or anything close to sufficient mitigation of noise, light and air pollution.
- Other alternatives for creating more soccer sites should be explored, such as revitalizing existing sites and public/private partnerships.

Please, I urge you not to allow this proposed soccer complex to be built. It would be devastating to the environment and to nearby communities. This area should remain open space. Now and into the future. It is an inappropriate location for this type of development.

Sincerely,

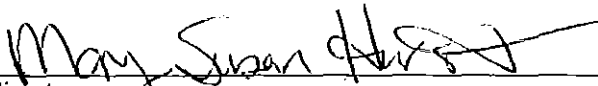

Signature
Mary Susan Hurst

Print Name

90 Mt. Teraya Dr. San Rafael, CA

Address
7/29/12

Date
94903

Attn: Gary O. Phillips, Mayor
Marc Levine, Councilmember
Damon Connolly, Councilmember
Barbara Heller, Councilmember
Andrew McCullough, Councilmember

Attn: Gary O. Phillips, Mayor
Marc Levine, Councilmember
Damon Connolly, Councilmember
Barbara Heller, Councilmember
Andrew McCullough, Councilmember

C/o: Kraig Tambornini, Senior Planner
City of San Rafael, Community Development
PO Box 151560
San Rafael, CA 94915-1560

RE: Proposed Airport Soccer Complex

Dear Mayor and Councilmembers:

I strongly urge you to not certify the Final Environmental Impact Report for the proposed San Rafael Airport Soccer Complex and not to approve zoning changes that would allow it to go forward.

I am deeply concerned about a number of aspects of this proposal, including:

- Safety of children and adults playing sports 160 feet from an active runway (why set aside state safety regulations and the warnings of Caltrans?). Not to mention the moral and liability issues of such a step. Planes have crashed there and it is not a question of "if" but "when" another will.
- Adult out-of-county leagues would be those most served by this pay to play, commercial project, more than local youth, as most parents in support have been led to believe.
- The public trust has been betrayed. The intent of the Deed of Restrictions on this property should of course be honored, as signatory and former Mayor Larry Mulryan has urged. The applicant/owner has already profited greatly from the development of Autodesk, Embassy Suites and Villa Marin, as was offered in exchange for keeping the airport area open and undeveloped.
- Wetland zoning allowing "low-impact" recreation is well-reasoned and should be kept in place, not rezoned to allow an 86,000 square foot commercial sports building and stadium lights.
- This would be a *calamity* for the quality of life for surrounding neighborhoods. The amount of noise, lights and traffic would seriously degrade people's ability to enjoy themselves on their own property or in surrounding open space. Prospective home buyers are already awaiting your decision.
- It is (now) a rich wildlife corridor and sensitive wetlands habitat, home to a great many types of animals, insects and plants (including one of the most Endangered Species in California, the Clapper Rail). This is not the place for a 12-hour a day, giant human development.
- Serious flaws in the FEIR have been found, including a lack of mitigation for the federally protected Clapper Rail, or anything close to sufficient mitigation of noise, light and air pollution.
- Other alternatives for creating more soccer sites should be explored, such as revitalizing existing sites and public/private partnerships.

Please, I urge you not to allow this proposed soccer complex to be built. It would be devastating to the environment and to nearby communities. This area should remain open space. Now and into the future. It is an inappropriate location for this type of development.

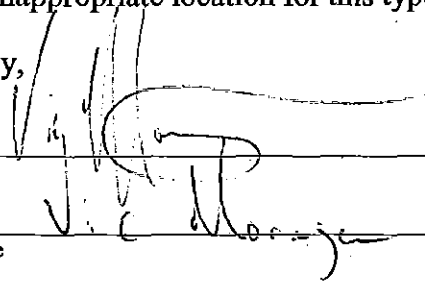
Sincerely,

Signature

Print Name

4415 Barrett Pl, Oakland, Ca

Address
4-29-12

Date

Attn: Gary O. Phillips, Mayor
Marc Levine, Councilmember
Damon Connolly, Councilmember
Barbara Heller, Councilmember
Andrew McCullough, Councilmember

C/o: Kraig Tambornini, Senior Planner
City of San Rafael, Community Development
PO Box 151560
San Rafael, CA 94915-1560

RE: Proposed Airport Soccer Complex

Dear Mayor and Councilmembers:

I strongly urge you to not certify the Final Environmental Impact Report for the proposed San Rafael Airport Soccer Complex and not to approve zoning changes that would allow it to go forward.

I am deeply concerned about a number of aspects of this proposal, including:

- Safety of children and adults playing sports 160 feet from an active runway (why set aside state safety regulations and the warnings of Caltrans?). Not to mention the moral and liability issues of such a step. Planes have crashed there and it is not a question of "if" but "when" another will.
- Adult out-of-county leagues would be those most served by this pay to play, commercial project, more than local youth, as most parents in support have been led to believe.
- The public trust has been betrayed. The intent of the Deed of Restrictions on this property should of course be honored, as signatory and former Mayor Larry Mulryan has urged. The applicant/owner has already profited greatly from the development of Autodesk, Embassy Suites and Villa Marin, as was offered in exchange for keeping the airport area open and undeveloped.
- Wetland zoning allowing "low-impact" recreation is well-reasoned and should be kept in place, not rezoned to allow an 86,000 square foot commercial sports building and stadium lights.
- This would be a *calamity* for the quality of life for surrounding neighborhoods. The amount of noise, lights and traffic would seriously degrade people's ability to enjoy themselves on their own property or in surrounding open space. Prospective home buyers are already awaiting your decision.
- It is (now) a rich wildlife corridor and sensitive wetlands habitat, home to a great many types of animals, insects and plants (including one of the most Endangered Species in California, the Clapper Rail). This is not the place for a 12-hour a day, giant human development.
- Serious flaws in the FEIR have been found, including a lack of mitigation for the federally protected Clapper Rail, or anything close to sufficient mitigation of noise, light and air pollution.
- Other alternatives for creating more soccer sites should be explored, such as revitalizing existing sites and public/private partnerships.

Please, I urge you not to allow this proposed soccer complex to be built. It would be devastating to the environment and to nearby communities. This area should remain open space. Now and into the future. It is an inappropriate location for this type of development.

Sincerely,

Signature

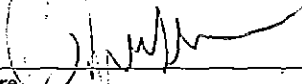

Print Name

CRAIG JENSEN

Address

1099 Adrian Way

Date

7/27/12

Attn: Gary O. Phillips, Mayor
Marc Levine, Councilmember
Damon Connolly, Councilmember
Barbara Heller, Councilmember
Andrew McCullough, Councilmember

C/o: Kraig Tambornini, Senior Planner
City of San Rafael, Community Development
PO Box 151560
San Rafael, CA 94915-1560

RE: Proposed Airport Soccer Complex

Dear Mayor and Councilmembers:

I strongly urge you to not certify the Final Environmental Impact Report for the proposed San Rafael Airport Soccer Complex and not to approve zoning changes that would allow it to go forward.

I am deeply concerned about a number of aspects of this proposal, including:

- Safety of children and adults playing sports 160 feet from an active runway (why set aside state safety regulations and the warnings of Caltrans?). Not to mention the moral and liability issues of such a step. Planes have crashed there and it is not a question of "if" but "when" another will.
- Adult out-of-county leagues would be those most served by this pay to play, commercial project, more than local youth, as most parents in support have been led to believe.
- The public trust has been betrayed. The intent of the Deed of Restrictions on this property should of course be honored, as signatory and former Mayor Larry Mulryan has urged. The applicant/owner has already profited greatly from the development of Autodesk, Embassy Suites and Villa Marin, as was offered in exchange for keeping the airport area open and undeveloped.
- Wetland zoning allowing "low-impact" recreation is well-reasoned and should be kept in place, not rezoned to allow an 86,000 square foot commercial sports building and stadium lights.
- This would be a *calamity* for the quality of life for surrounding neighborhoods. The amount of noise, lights and traffic would seriously degrade people's ability to enjoy themselves on their own property or in surrounding open space. Prospective home buyers are already awaiting your decision.
- It is (now) a rich wildlife corridor and sensitive wetlands habitat, home to a great many types of animals, insects and plants (including one of the most Endangered Species in California, the Clapper Rail). This is not the place for a 12-hour a day, giant human development.
- Serious flaws in the FEIR have been found, including a lack of mitigation for the federally protected Clapper-Rail, or anything close to sufficient mitigation of noise, light and air pollution.
- Other alternatives for creating more soccer sites should be explored, such as revitalizing existing sites and public/private partnerships.

Please, I urge you not to allow this proposed soccer complex to be built. It would be devastating to the environment and to nearby communities. This area should remain open space. Now and into the future. It is an inappropriate location for this type of development.

Sincerely,

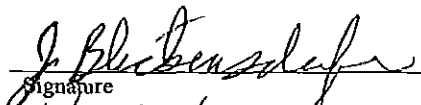

Signature
John Blickeusderfer

Print Name

165 Carson Woodacre, CA

Address
7-30-12

Date

Attn: Gary O. Phillips, Mayor
Marc Levine, Councilmember
Damon Connolly, Councilmember
Barbara Heller, Councilmember
Andrew McCullough, Councilmember

C/o: Kraig Tambornini, Senior Planner
City of San Rafael, Community Development
PO Box 151560
San Rafael, CA 94915-1560

RE: Proposed Airport Soccer Complex

Dear Mayor and Councilmembers:

I strongly urge you to not certify the Final Environmental Impact Report for the proposed San Rafael Airport Soccer Complex and not to approve zoning changes that would allow it to go forward.

I am deeply concerned about a number of aspects of this proposal, including:

- Safety of children and adults playing sports 160 feet from an active runway (why set aside state safety regulations and the warnings of Caltrans?). Not to mention the moral and liability issues of such a step. Planes have crashed there and it is not a question of "if" but "when" another will.
- Adult out-of-county leagues would be those most served by this pay to play, commercial project, more than local youth, as most parents in support have been led to believe.
- The public trust has been betrayed. The intent of the Deed of Restrictions on this property should of course be honored, as signatory and former Mayor Larry Mulryan has urged. The applicant/owner has already profited greatly from the development of Autodesk, Embassy Suites and Villa Marin, as was offered in exchange for keeping the airport area open and undeveloped.
- Wetland zoning allowing "low-impact" recreation is well-reasoned and should be kept in place, not rezoned to allow an 86,000 square foot commercial sports building and stadium lights.
- This would be a *calamity* for the quality of life for surrounding neighborhoods. The amount of noise, lights and traffic would seriously degrade people's ability to enjoy themselves on their own property or in surrounding open space. Prospective home buyers are already awaiting your decision.
- It is (now) a rich wildlife corridor and sensitive wetlands habitat, home to a great many types of animals, insects and plants (including one of the most Endangered Species in California, the Clapper Rail). This is not the place for a 12-hour a day, giant human development.
- Serious flaws in the FEIR have been found, including a lack of mitigation for the federally protected Clapper Rail, or anything close to sufficient mitigation of noise, light and air pollution.
- Other alternatives for creating more soccer sites should be explored, such as revitalizing existing sites and public/private partnerships.

Please, I urge you not to allow this proposed soccer complex to be built. It would be devastating to the environment and to nearby communities. This area should remain open space. Now and into the future. It is an inappropriate location for this type of development.

Sincerely,

Betty Souch

Signature

Betty Souch

Print Name

165 Carson Rd, Woodacre,
Address
7/29/12
Date
CA 94973

Attn: Gary O. Phillips, Mayor
Marc Levine, Councilmember
Damon Connolly, Councilmember
Barbara Heller, Councilmember
Andrew McCullough, Councilmember

C/o: Kraig Tambornini, Senior Planner
City of San Rafael, Community Development
PO Box 151560
San Rafael, CA 94915-1560

RE: Proposed Airport Soccer Complex

Dear Mayor and Councilmembers:

I strongly urge you to not certify the Final Environmental Impact Report for the proposed San Rafael Airport Soccer Complex and not to approve zoning changes that would allow it to go forward.

I am deeply concerned about a number of aspects of this proposal, including:

- Safety of children and adults playing sports 160 feet from an active runway (why set aside state safety regulations and the warnings of Caltrans?). Not to mention the moral and liability issues of such a step. Planes have crashed there and it is not a question of "if" but "when" another will.
- Adult out-of-county leagues would be those most served by this pay to play, commercial project, more than local youth, as most parents in support have been led to believe.
- The public trust has been betrayed. The intent of the Deed of Restrictions on this property should of course be honored, as signatory and former Mayor Larry Mulryan has urged. The applicant/owner has already profited greatly from the development of Autodesk, Embassy Suites and Villa Marin, as was offered in exchange for keeping the airport area open and undeveloped.
- Wetland zoning allowing "low-impact" recreation is well-reasoned and should be kept in place, not rezoned to allow an 86,000 square foot commercial sports building and stadium lights.
- This would be a *calamity* for the quality of life for surrounding neighborhoods. The amount of noise, lights and traffic would seriously degrade people's ability to enjoy themselves on their own property or in surrounding open space. Prospective home buyers are already awaiting your decision.
- It is (now) a rich wildlife corridor and sensitive wetlands habitat, home to a great many types of animals, insects and plants (including one of the most Endangered Species in California, the Clapper Rail). This is not the place for a 12-hour a day, giant human development.
- Serious flaws in the FEIR have been found, including a lack of mitigation for the federally protected Clapper Rail, or anything close to sufficient mitigation of noise, light and air pollution.
- Other alternatives for creating more soccer sites should be explored, such as revitalizing existing sites and public/private partnerships.

Please, I urge you not to allow this proposed soccer complex to be built. It would be devastating to the environment and to nearby communities. This area should remain open space. Now and into the future. It is an inappropriate location for this type of development.

Sincerely,

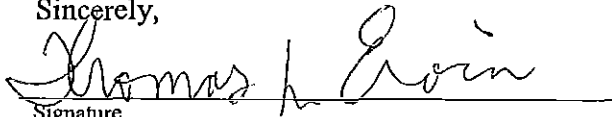
Signature
Thomas L. Ervin
Print Name

945 Las Vegas Avenue
Address
7/29/2012
Date

Attn: Gary O. Phillips, Mayor
Marc Levine, Councilmember
Damon Connolly, Councilmember
Barbara Heller, Councilmember
Andrew McCullough, Councilmember

C/o: Kraig Tambornini, Senior Planner
City of San Rafael, Community Development
PO Box 151560
San Rafael, CA 94915-1560

RE: Proposed Airport Soccer Complex

Dear Mayor and Councilmembers:

I strongly urge you to not certify the Final Environmental Impact Report for the proposed San Rafael Airport Soccer Complex and not to approve zoning changes that would allow it to go forward.

I am deeply concerned about a number of aspects of this proposal, including:

- Safety of children and adults playing sports 160 feet from an active runway (why set aside state safety regulations and the warnings of Caltrans?). Not to mention the moral and liability issues of such a step. Planes have crashed there and it is not a question of "if" but "when" another will.
- Adult out-of-county leagues would be those most served by this pay to play, commercial project, more than local youth, as most parents in support have been led to believe.
- The public trust has been betrayed. The intent of the Deed of Restrictions on this property should of course be honored, as signatory and former Mayor Larry Mulryan has urged. The applicant/owner has already profited greatly from the development of Autodesk, Embassy Suites and Villa Marin, as was offered in exchange for keeping the airport area open and undeveloped.
- Wetland zoning allowing "low-impact" recreation is well-reasoned and should be kept in place, not rezoned to allow an 86,000 square foot commercial sports building and stadium lights.
- This would be a *calamity* for the quality of life for surrounding neighborhoods. The amount of noise, lights and traffic would seriously degrade people's ability to enjoy themselves on their own property or in surrounding open space. Prospective home buyers are already awaiting your decision.
- It is (now) a rich wildlife corridor and sensitive wetlands habitat, home to a great many types of animals, insects and plants (including one of the most Endangered Species in California, the Clapper Rail). This is not the place for a 12-hour a day, giant human development.
- Serious flaws in the FEIR have been found, including a lack of mitigation for the federally protected Clapper Rail, or anything close to sufficient mitigation of noise, light and air pollution.
- Other alternatives for creating more soccer sites should be explored, such as revitalizing existing sites and public/private partnerships.

Please, I urge you not to allow this proposed soccer complex to be built. It would be devastating to the environment and to nearby communities. This area should remain open space. Now and into the future. It is an inappropriate location for this type of development.

Sincerely,

Christine Kraemer
Signature

75 Vendola Drive, San Rafael, 94903
Address

Christine Kraemer
Print Name

7/27/12
Date

Attn: Gary O. Phillips, Mayor
Marc Levine, Councilmember
Damon Connolly, Councilmember
Barbara Heller, Councilmember
Andrew McCullough, Councilmember

C/o: Kraig Tambornini, Senior Planner
City of San Rafael, Community Development
PO Box 151560
San Rafael, CA 94915-1560

RE: Proposed Airport Soccer Complex

Dear Mayor and Councilmembers:

I strongly urge you to not certify the Final Environmental Impact Report for the proposed San Rafael Airport Soccer Complex and not to approve zoning changes that would allow it to go forward.

I am deeply concerned about a number of aspects of this proposal, including:

- Safety of children and adults playing sports 160 feet from an active runway (why set aside state safety regulations and the warnings of Caltrans?). Not to mention the moral and liability issues of such a step. Planes have crashed there and it is not a question of "if" but "when" another will.
- Adult out-of-county leagues would be those most served by this pay to play, commercial project, more than local youth, as most parents in support have been led to believe.
- The public trust has been betrayed. The intent of the Deed of Restrictions on this property should of course be honored, as signatory and former Mayor Larry Mulryan has urged. The applicant/owner has already profited greatly from the development of Autodesk, Embassy Suites and Villa Marin, as was offered in exchange for keeping the airport area open and undeveloped.
- Wetland zoning allowing "low-impact" recreation is well-reasoned and should be kept in place, not rezoned to allow an 86,000 square foot commercial sports building and stadium lights.
- This would be a *calamity* for the quality of life for surrounding neighborhoods. The amount of noise, lights and traffic would seriously degrade people's ability to enjoy themselves on their own property or in surrounding open space. Prospective home buyers are already awaiting your decision.
- It is (now) a rich wildlife corridor and sensitive wetlands habitat, home to a great many types of animals, insects and plants (including one of the most Endangered Species in California, the Clapper Rail). This is not the place for a 12-hour a day, giant human development.
- Serious flaws in the FEIR have been found, including a lack of mitigation for the federally protected Clapper Rail, or anything close to sufficient mitigation of noise, light and air pollution.
- Other alternatives for creating more soccer sites should be explored, such as revitalizing existing sites and public/private partnerships.

Please, I urge you not to allow this proposed soccer complex to be built. It would be devastating to the environment and to nearby communities. This area should remain open space. Now and into the future. It is an inappropriate location for this type of development.

Sincerely,

Signature

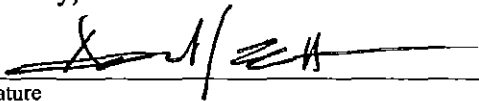

Print Name

Daniel J. Ellis

Address

75 Vendola Dr. San Rafael 94903

Date

7/29/12

Attn: Gary O. Phillips, Mayor
Marc Levine, Councilmember
Damon Connolly, Councilmember
Barbara Heller, Councilmember
Andrew McCullough, Councilmember

C/o: Kraig Tambornini, Senior Planner
City of San Rafael, Community Development
PO Box 151560
San Rafael, CA 94915-1560

RE: Proposed Airport Soccer Complex

Dear Mayor and Councilmembers:

I strongly urge you to not certify the Final Environmental Impact Report for the proposed San Rafael Airport Soccer Complex and not to approve zoning changes that would allow it to go forward.

I am deeply concerned about a number of aspects of this proposal, including:

- Safety of children and adults playing sports 160 feet from an active runway (why set aside state safety regulations and the warnings of Caltrans?). Not to mention the moral and liability issues of such a step. Planes have crashed there and it is not a question of "if" but "when" another will.
- Adult out-of-county leagues would be those most served by this pay to play, commercial project, more than local youth, as most parents in support have been led to believe.
- The public trust has been betrayed. The intent of the Deed of Restrictions on this property should of course be honored, as signatory and former Mayor Larry Mulryan has urged. The applicant/owner has already profited greatly from the development of Autodesk, Embassy Suites and Villa Marin, as was offered in exchange for keeping the airport area open and undeveloped.
- Wetland zoning allowing "low-impact" recreation is well-reasoned and should be kept in place, not rezoned to allow an 86,000 square foot commercial sports building and stadium lights.
- This would be a *calamity* for the quality of life for surrounding neighborhoods. The amount of noise, lights and traffic would seriously degrade people's ability to enjoy themselves on their own property or in surrounding open space. Prospective home buyers are already awaiting your decision.
- It is (now) a rich wildlife corridor and sensitive wetlands habitat, home to a great many types of animals, insects and plants (including one of the most Endangered Species in California, the Clapper Rail). This is not the place for a 12-hour a day, giant human development.
- Serious flaws in the FEIR have been found, including a lack of mitigation for the federally protected Clapper Rail, or anything close to sufficient mitigation of noise, light and air pollution.
- Other alternatives for creating more soccer sites should be explored, such as revitalizing existing sites and public/private partnerships.

Please, I urge you not to allow this proposed soccer complex to be built. It would be devastating to the environment and to nearby communities. This area should remain open space. Now and into the future. It is an inappropriate location for this type of development.

Sincerely,

Cassandra Coffee

Signature

Cassandra Coffee

Print Name

68 Vendola Dr

Address

7-28-12

Date

Attn: Gary O. Phillips, Mayor
Marc Levine, Councilmember
Damon Connolly, Councilmember
Barbara Heller, Councilmember
Andrew McCullough, Councilmember

C/o: Kraig Tambornini, Senior Planner
City of San Rafael, Community Development
PO Box 151560
San Rafael, CA 94915-1560

RE: Proposed Airport Soccer Complex

Dear Mayor and Councilmembers:

I strongly urge you to not certify the Final Environmental Impact Report for the proposed San Rafael Airport Soccer Complex and not to approve zoning changes that would allow it to go forward.

I am deeply concerned about a number of aspects of this proposal, including:

- Safety of children and adults playing sports 160 feet from an active runway (why set aside state safety regulations and the warnings of Caltrans?). Not to mention the moral and liability issues of such a step. Planes have crashed there and it is not a question of "if" but "when" another will.
- Adult out-of-county leagues would be those most served by this pay to play, commercial project, more than local youth, as most parents in support have been led to believe.
- The public trust has been betrayed. The intent of the Deed of Restrictions on this property should of course be honored, as signatory and former Mayor Larry Mulryan has urged. The applicant/owner has already profited greatly from the development of Autodesk, Embassy Suites and Villa Marin, as was offered in exchange for keeping the airport area open and undeveloped.
- Wetland zoning allowing "low-impact" recreation is well-reasoned and should be kept in place, not rezoned to allow an 86,000 square foot commercial sports building and stadium lights.
- This would be a *calamity* for the quality of life for surrounding neighborhoods. The amount of noise, lights and traffic would seriously degrade people's ability to enjoy themselves on their own property or in surrounding open space. Prospective home buyers are already awaiting your decision.
- It is (now) a rich wildlife corridor and sensitive wetlands habitat, home to a great many types of animals, insects and plants (including one of the most Endangered Species in California, the Clapper Rail). This is not the place for a 12-hour a day, giant human development.
- Serious flaws in the FEIR have been found, including a lack of mitigation for the federally protected Clapper Rail, or anything close to sufficient mitigation of noise, light and air pollution.
- Other alternatives for creating more soccer sites should be explored, such as revitalizing existing sites and public/private partnerships.

Please, I urge you not to allow this proposed soccer complex to be built. It would be devastating to the environment and to nearby communities. This area should remain open space. Now and into the future. It is an inappropriate location for this type of development.

Sincerely,

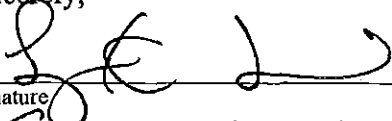

Signature
Sonya Souki

Print Name

75 Vendola Dr., San Rafael, CA

Address
7/22/12

Date
94903

Attn: Gary O. Phillips, Mayor
Marc Levine, Councilmember
Damon Connolly, Councilmember
Barbara Heller, Councilmember
Andrew McCullough, Councilmember

C/o: Kraig Tambornini, Senior Planner
City of San Rafael, Community Development
PO Box 151560
San Rafael, CA 94915-1560

RE: Proposed Airport Soccer Complex

Dear Mayor and Councilmembers:

I strongly urge you to not certify the Final Environmental Impact Report for the proposed San Rafael Airport Soccer Complex and not to approve zoning changes that would allow it to go forward.

I am deeply concerned about a number of aspects of this proposal, including:

- Safety of children and adults playing sports 160 feet from an active runway (why set aside state safety regulations and the warnings of Caltrans?). Not to mention the moral and liability issues of such a step. Planes have crashed there and it is not a question of "if" but "when" another will.
- Adult out-of-county leagues would be those most served by this pay to play, commercial project, more than local youth, as most parents in support have been led to believe.
- The public trust has been betrayed. The intent of the Deed of Restrictions on this property should of course be honored, as signatory and former Mayor Larry Mulryan has urged. The applicant/owner has already profited greatly from the development of Autodesk, Embassy Suites and Villa Marin, as was offered in exchange for keeping the airport area open and undeveloped.
- Wetland zoning allowing "low-impact" recreation is well-reasoned and should be kept in place, not rezoned to allow an 86,000 square foot commercial sports building and stadium lights.
- This would be a *calamity* for the quality of life for surrounding neighborhoods. The amount of noise, lights and traffic would seriously degrade people's ability to enjoy themselves on their own property or in surrounding open space. Prospective home buyers are already awaiting your decision.
- It is (now) a rich wildlife corridor and sensitive wetlands habitat, home to a great many types of animals, insects and plants (including one of the most Endangered Species in California, the Clapper Rail). This is not the place for a 12-hour a day, giant human development.
- Serious flaws in the FEIR have been found, including a lack of mitigation for the federally protected Clapper Rail, or anything close to sufficient mitigation of noise, light and air pollution.
- Other alternatives for creating more soccer sites should be explored, such as revitalizing existing sites and public/private partnerships.

Please, I urge you not to allow this proposed soccer complex to be built. It would be devastating to the environment and to nearby communities. This area should remain open space. Now and into the future. It is an inappropriate location for this type of development.

Sincerely,

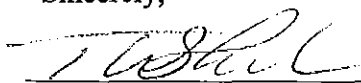

Signature
Tom Wheeler

Print Name

75 Vendola Dr San Rafael

Address
7/26/12

Date

Attn: Gary O. Phillips, Mayor
Marc Levine, Councilmember
Damon Connolly, Councilmember
Barbara Heller, Councilmember
Andrew McCullough, Councilmember

C/o: Kraig Tamborini, Senior Planner
City of San Rafael, Community Development
PO Box 151560
San Rafael, CA 94915-1560

RE: Proposed Airport Soccer Complex

Dear Mayor and Councilmembers:

I strongly urge you to not certify the Final Environmental Impact Report for the proposed San Rafael Airport Soccer Complex and not to approve zoning changes that would allow it to go forward.

I am deeply concerned about a number of aspects of this proposal, including:

- Safety of children and adults playing sports 160 feet from an active runway (why set aside state safety regulations and the warnings of Caltrans?). Not to mention the moral and liability issues of such a step. Planes have crashed there and it is not a question of "if" but "when" another will.
- Adult out-of-county leagues would be those most served by this pay to play, commercial project, more than local youth, as most parents in support have been led to believe.
- The public trust has been betrayed. The intent of the Deed of Restrictions on this property should of course be honored, as signatory and former Mayor Larry Mulryan has urged. The applicant/owner has already profited greatly from the development of Autodesk, Embassy Suites and Villa Marin, as was offered in exchange for keeping the airport area open and undeveloped.
- Wetland zoning allowing "low-impact" recreation is well-reasoned and should be kept in place, not rezoned to allow an 86,000 square foot commercial sports building and stadium lights.
- This would be a *calamity* for the quality of life for surrounding neighborhoods. The amount of noise, lights and traffic would seriously degrade people's ability to enjoy themselves on their own property or in surrounding open space. Prospective home buyers are already awaiting your decision.
- It is (now) a rich wildlife corridor and sensitive wetlands habitat, home to a great many types of animals, insects and plants (including one of the most Endangered Species in California, the Clapper Rail). This is not the place for a 12-hour a day, giant human development.
- Serious flaws in the FEIR have been found, including a lack of mitigation for the federally protected Clapper Rail, or anything close to sufficient mitigation of noise, light and air pollution.
- Other alternatives for creating more soccer sites should be explored, such as revitalizing existing sites and public/private partnerships.

Please, I urge you not to allow this proposed soccer complex to be built. It would be devastating to the environment and to nearby communities. This area should remain open space. Now and into the future. It is an inappropriate location for this type of development.

Sincerely,

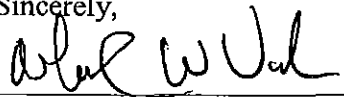

Signature
Michael W. Vurek

Print Name

57 San Gabriel Dr. Fairfax CA 94930

Address
7/25/12

Date

Attn: Gary O. Phillips, Mayor
Marc Levine, Councilmember
Damon Connolly, Councilmember
Barbara Heller, Councilmember
Andrew McCullough, Councilmember

C/o: Kraig Tambornini, Senior Planner
City of San Rafael, Community Development
PO Box 151560
San Rafael, CA 94915-1560

RE: Proposed Airport Soccer Complex

Dear Mayor and Councilmembers:

I strongly urge you to not certify the Final Environmental Impact Report for the proposed San Rafael Airport Soccer Complex and not to approve zoning changes that would allow it to go forward.

I am deeply concerned about a number of aspects of this proposal, including:

- Safety of children and adults playing sports 160 feet from an active runway (why set aside state safety regulations and the warnings of Caltrans?). Not to mention the moral and liability issues of such a step. Planes have crashed there and it is not a question of "if" but "when" another will.
- Adult out-of-county leagues would be those most served by this pay to play, commercial project, more than local youth, as most parents in support have been led to believe.
- The public trust has been betrayed. The intent of the Deed of Restrictions on this property should of course be honored, as signatory and former Mayor Larry Mulryan has urged. The applicant/owner has already profited greatly from the development of Autodesk, Embassy Suites and Villa Marin, as was offered in exchange for keeping the airport area open and undeveloped.
- Wetland zoning allowing "low-impact" recreation is well-reasoned and should be kept in place, not rezoned to allow an 86,000 square foot commercial sports building and stadium lights.
- This would be a *calamity* for the quality of life for surrounding neighborhoods. The amount of noise, lights and traffic would seriously degrade people's ability to enjoy themselves on their own property or in surrounding open space. Prospective home buyers are already awaiting your decision.
- It is (now) a rich wildlife corridor and sensitive wetlands habitat, home to a great many types of animals, insects and plants (including one of the most Endangered Species in California, the Clapper Rail). This is not the place for a 12-hour a day, giant human development.
- Serious flaws in the FEIR have been found, including a lack of mitigation for the federally protected Clapper Rail, or anything close to sufficient mitigation of noise, light and air pollution.
- Other alternatives for creating more soccer sites should be explored, such as revitalizing existing sites and public/private partnerships.

Please, I urge you not to allow this proposed soccer complex to be built. It would be devastating to the environment and to nearby communities. This area should remain open space. Now and into the future. It is an inappropriate location for this type of development.

Sincerely,

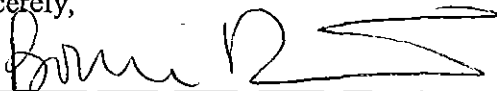

Signature

BONNIE BIBAS

Print Name

Box 295 Ross, CA

Address

7/25/12

Date