



## San Rafael Fire Department

### Hillside Parcel Fire Apparatus Access and Water Supply – One to Two Single Family Dwelling Project

Submit a FIRE PROTECTION PLAN prepared by a qualified professional

Conformance with this criteria does not ensure approval of the overall project based on other Department/Agency requirements.

- Reference the City of San Rafael Municipal Code Chapter 4 in its entirety.
- Reference the 2016 edition of the CA Fire Code (CFC) and all applicable 2016 NFPA standards.
- Contact City of San Rafael Planning, Building and Public Works Departments for additional requirements.
- Contact Marin Municipal Water District (MMWD) for water system information.
- Alternate means and methods will be considered and must be submitted as part of a comprehensive fire protection plan for the property that also includes a vegetation management plan.

**ACCESS** (CFC Section 503 and Appendix D) Contact DPW/Engineering for additional criteria.

1. A Fire Apparatus Access Road is required to extend to within 150' of all portions of the facility and all portions of the exterior walls of the first story of the building as measured by an approved route around the exterior of building or facility. (Exceptions to the distance requirement for a single dwelling may apply and must be approved by the Fire Chief.) A Fire Apparatus Access Road must conform to all provisions of this section and roadway criteria as set forth by the City of San Rafael Public Works Department.
  - a. Private drive 14' minimum width "all weather" material. Public road 20' minimum width.
  - b. Approved turnaround is required for roads the exceed 150' in distance. See CFC Figure D103.1.
  - c. Roads, bridges and retaining walls to support 40,000 pounds (min) vehicle weight.
  - d. 14% maximum grade.
  - e. Turning radius minimum is 30' 6". See diagram page 2.
    - i. Turnouts are not allowed on inside of curves.
  - f. All curbs to be painted red with FIRE LANE stenciled at regular intervals. Signage approved by San Rafael Parking Services and must be enforceable. Must be maintained recorded in deed.
  - g. Angles of approach and departure to meet San Rafael requirements for fire apparatus.
    - i. Front - Approach: 15.00 degrees.
    - ii. Rear - Departure: 11.50 degrees.
  - h. Vertical clearance 13'6".
  - i. Fire apparatus access roads shall not be obstructed in any manner, including the parking of vehicles.
  - j. Gates across access roads shall be approved by the Fire Chief and have KNOX key access. Gates must provide 20' of clear opening.
  - k. Where a hydrant is required, 26' of roadway width is required.
  - l. Contact San Rafael Department of Public Works for additional roadway criteria and requirements.

**FIRE PROTECTION WATER SUPPLIES** (CFC section 507, CFC Appendix B, & NFPA 13D, 13R, 24)

All portions of a facility or building is to be 600' from hydrant on fire apparatus access road as measured by an approved route around the exterior of the facility or building with an approved fire sprinkler system.

1. Minimum fire flow @ 100 psi static pressure:
  - a. <3600 square feet = 500 gpm for 30 minutes.
  - b. >3600 square feet = 800 gpm for 1 hour.
2. Private fire service mains and tanks shall be periodically inspected and tested in accordance with CC&R Title 19, Division 1, Chapter 5.
3. Private fire service mains shall conform to NFPA 24 as amended in CFC chapter 80.
4. Contact MMWD to obtain additional water supply information.
5. No drafting or similar static sources are allowed for fire flow.
6. All water supplies must be from an approved, permanent source using universally recognized equipment.
7. A residential fire sprinkler system conforming to NFPA 13-D is required.

**OTHER REQUIREMENTS** (partial list)

- If the property is located within a Wildland-Urban Interface (WUI) area, provide a written Vegetation Management Plan (VMP) submitted to the San Rafael Fire Department. This VMP must be completed and verified prior to final approval. Requirement of continued compliance with the approved VMP must be recorded on deed. Contact Fire Prevention at 415-458-3308 for more information. Reference: <https://www.cityofsanrafael.org/vmp-san-rafael-fd/>
- Contact San Rafael Building Department for additional information on CA Building Code Chapter 7A (WUI building construction and material requirements).

**ACCESS ROADWAY INFO** (Turning Radius - Approved Turnaround – Hydrant Clearance)

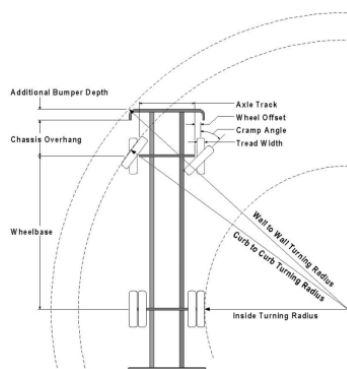

**Parameters:**

Inside Cramp Angle:	45°
Axle Track:	86.17 in.
Wheel Offset:	3.12 in.
Tread Width:	12.4 in.
Chassis Overhang:	65.95 in.
Additional Bumper Depth:	7 in.
Front Overhang:	72.95 in.
Wheelbase:	174.5 in.

**Calculated Turning Radii:**

Inside Turn:	13 ft. 9 in.
Curb to curb:	26 ft. 11 in.
Wall to wall:	30 ft. 6 in.

**Comments:**  
San Rafael, CA

APPENDIX D

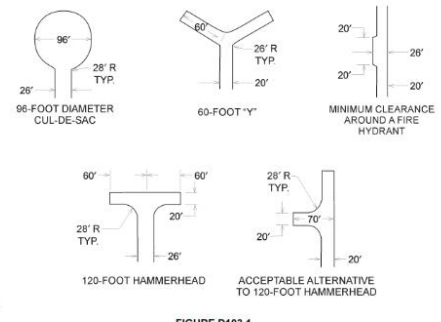

San Rafael Fire Department: 415-485-3304 <https://www.cityofsanrafael.org/departments/fire/>

San Rafael Building/Planning Department: 415-485-3085 <https://www.cityofsanrafael.org/departments/community-development/>

San Rafael Public Works Department: 415-485-3355 <https://www.cityofsanrafael.org/departments/public-works/>

MMWD: 415-945-1455 <https://www.marinwater.org/>