

M:\County Standards\County UCS\2018 Updated County Standards\UCS 330.dwg

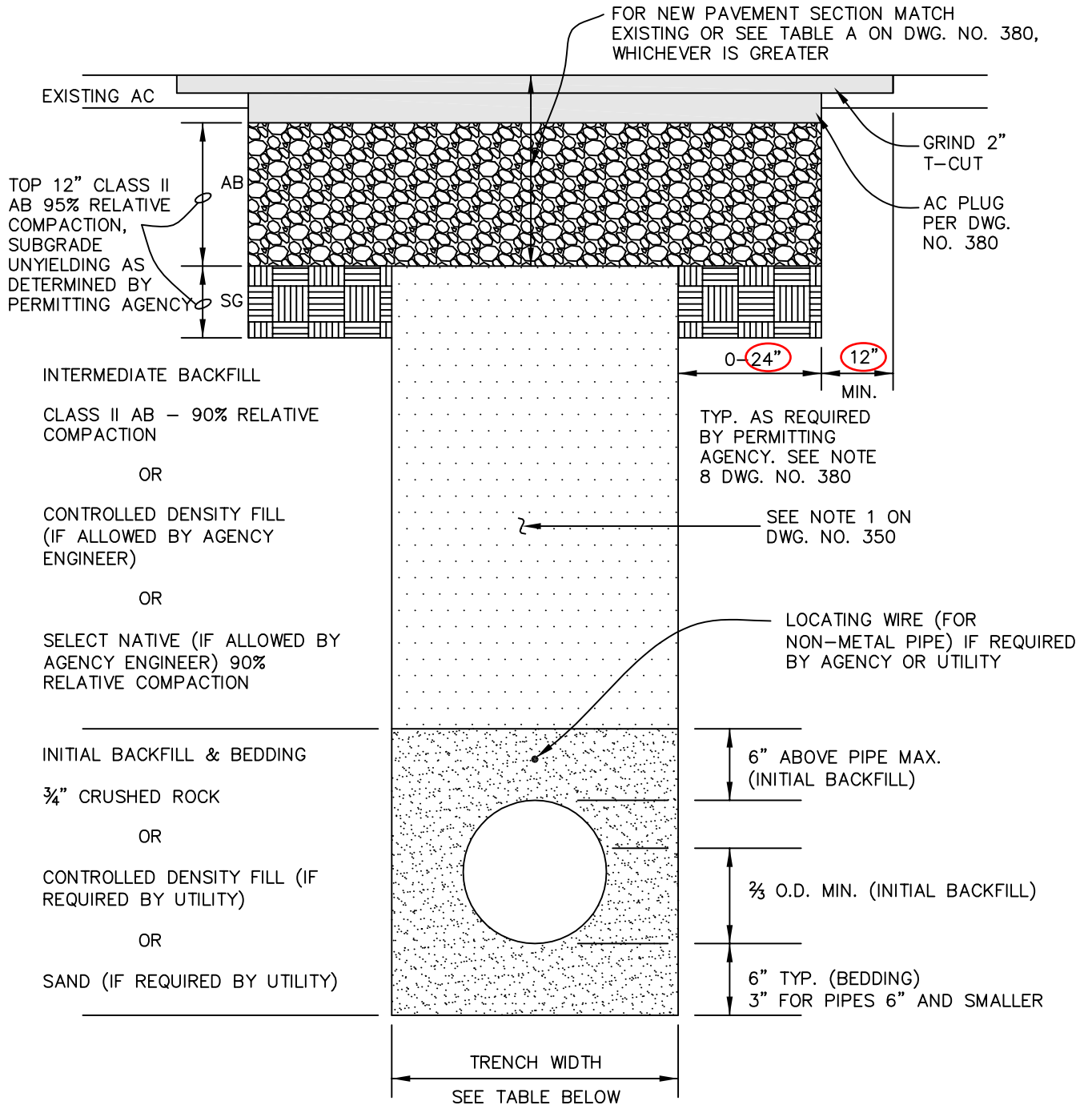

**NOTE:** IF ROADWAY HAS EXISTING AC OVER CONCRETE, TRENCH RESTORATION SHALL BE DETERMINED BY THE AGENCY ENGINEER.

### TYPE 1

#### ASPHALT CONCRETE PAVED STREETS

CONDUIT SIZE	LESS THAN 6"	6" TO 24"	OVER 24" TO 60"	OVER 60"
TRENCH WIDTH	O.D. + 12"	O.D. + 24"	O.D. + 24"	O.D. + 24"

FOR PIPES WITH MORE THAN 36" OF COVER, THE AGENCY ENGINEER MAY ALLOW A REDUCED TRENCH WIDTH INCLUDING A CHANGE TO A SELF-COMPACTING ENGINEERED TYPE OF INITIAL BACKFILL MATERIAL.

UNIFORM STANDARDS  
ALL CITIES AND  
COUNTY OF MARIN

TRENCH DETAILS  
SHEET 1 OF 3

			MARCH 2018
			DWG. NO.
			330
REV.	DATE	BY	

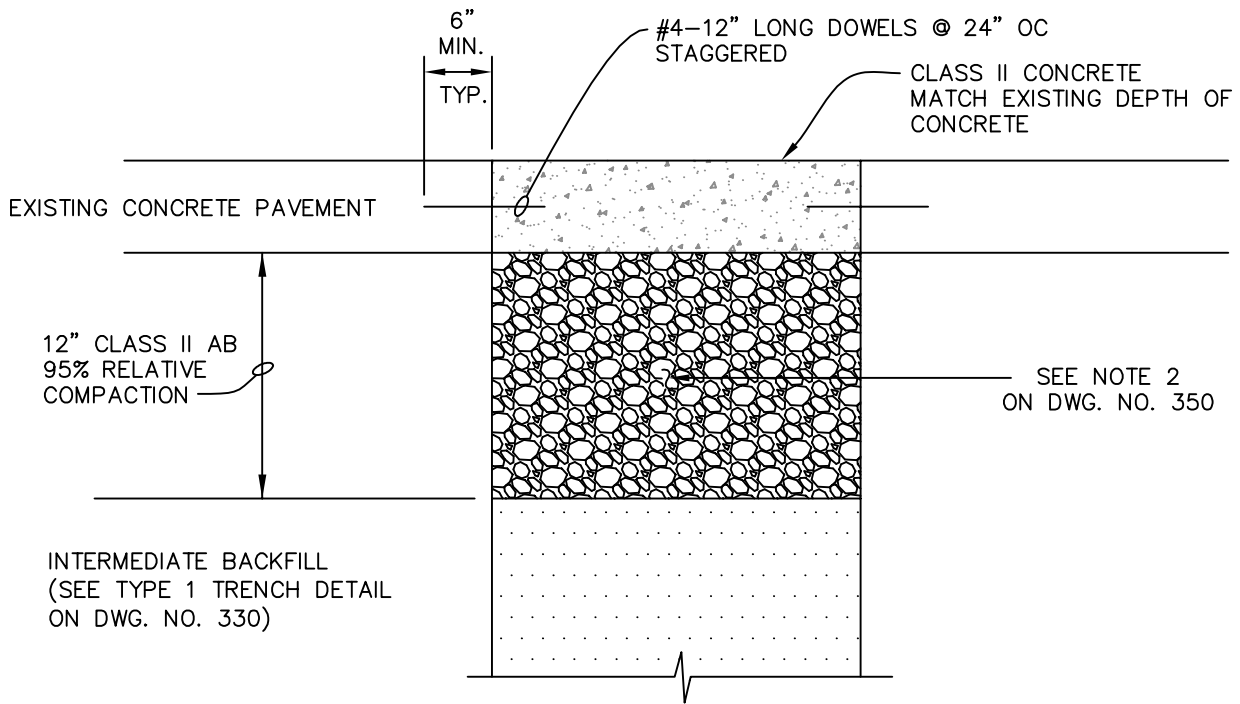

**TYPE 2**

CONCRETE PAVED STREETS

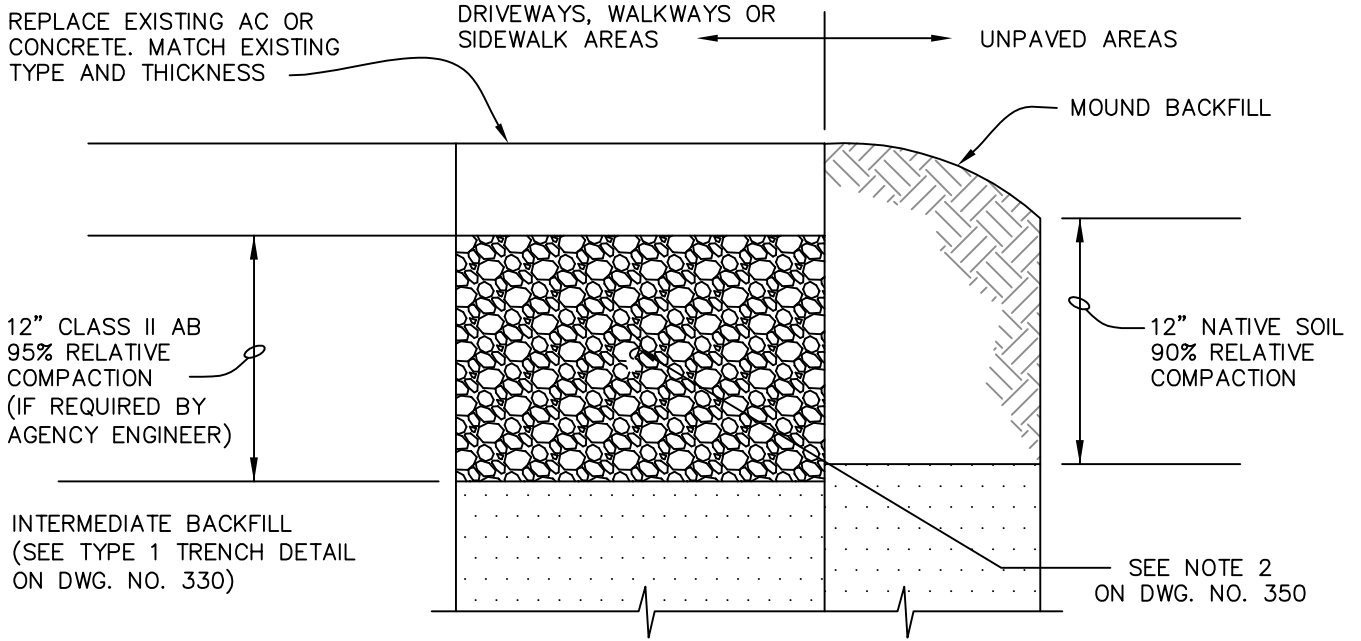

**TYPE 3**

AREAS OTHER THAN STREETS IN THE PUBLIC RIGHT OF WAY

**NOTE:** FOR TRENCHES IN UNPAVED SHOULDERS, TOP 12" SHALL BE CLASS II AB 95% RELATIVE COMPACTION.

M:\County Standards\County UCS\2018 Updated County Standards\UCS 340.dwg

UNIFORM STANDARDS  
ALL CITIES AND  
COUNTY OF MARIN

STANDARD  
TRENCH BACKFILL  
& RESURFACING  
SHEET 2 OF 3

			MARCH 2018
			DWG. NO.
			340
REV.	DATE	BY	

## MATERIAL AND COMPACTION REQUIREMENT FOR TRENCH BACKFILL

1. INTERMEDIATE BACKFILL SHALL BE CLASS II AGGREGATE BASE. SUITABLE NATIVE OR IMPORTED GRANULAR MATERIAL MAY BE USED IF ALLOWED BY AGENCY ENGINEER. RELATIVE COMPACTION SHALL BE AT LEAST 90%.
2. CLASS II AGGREGATE BASE SHALL CONFORM TO THE STATE STANDARD SPECIFICATIONS. MINIMUM RELATIVE COMPACTION SHALL BE 95%. IF PAVEMENT HAVING A STRUCTURAL SECTION GREATER THAN 15" IS CUT, ADDITIONAL BASE MATERIAL MAY BE REQUIRED BY THE AGENCY ENGINEER. BASE SHALL BE PLACED AND COMPACTED PRIOR TO PLACING OF TEMPORARY PAVING.
3. TESTING OF MATERIALS AND PERFORMANCE SHALL BE IN CONFORMANCE WITH THE METHODS STATED IN THE LATEST EDITION OF THE STATE OF CALIFORNIA, DEPARTMENT OF TRANSPORTATION, STANDARD SPECIFICATIONS, EXCEPT THAT RELATIVE COMPACTION MAY BE TESTED BY AASHTO METHOD T180, ASTM D-1557, OR TEST METHOD CALIF. 231 (NUCLEAR DENSITOMETER).
4. PLACE AC IN 3" MAX, LIFTS, EXCEPT FINAL LIFT SHALL BE 2 1/2" MAX. ADDITIONAL THICKNESS AND LIFTS OF ASPHALT CONCRETE MAY BE REQUIRED TO MATCH EXISTING STRUCTURAL SECTION ON MAJOR ROADS, OR PER LOCAL JURISDICTION REQUIREMENTS.
5. "JETTING" OF BACKFILL MATERIAL IS NOT PERMITTED.
6. THE USE OF PEA GRAVEL (OR SIMILAR ROUNDED AGGREGATE), IS NOT PERMITTED.
7. THE USE OF CONTROLLED DENSITY FILL (CDF) SHALL BE APPROVED BY THE AGENCY ENGINEER PRIOR TO PLACEMENT.
8. TRENCH EDGES SHALL BE TRIMMED TO A NEAT LINE AS REQUIRED BY THE AGENCY ENGINEER. TRIMMING SHALL BE BY ROTARY GRINDER. TRENCH LINES SHALL HAVE THE LEAST AMOUNT OF JOGS AND REMAIN LINEAR AS MUCH AS POSSIBLE. REFERENCE DRAWING NO. 360, 370 & 380.
9. THE SURFACE COURSE OF TRENCH RESTORATION SHALL EXTEND TO THE LIP OF GUTTER IF THE EDGE OF TRENCH IS WITHIN 4' OF THE LIP OF GUTTER, AND TO THE EDGE OF PAVEMENT IF THE EDGE OF TRENCH IS WITHIN 4' OF AN UNPAVED SHOULDER.
10. CONTRACTOR MUST SHORE ALL TRENCHES IN CONFORMANCE WITH OSHA AND STATE SAFETY STANDARDS.
11. ALL HOT MIX ASPHALT (HMA) MATERIAL, METHODS AND TOLERANCES SHALL BE IN COMPLIANCE WITH THE CURRENT EDITION OF THE CALTRANS STANDARD SPECIFICATIONS.

M:\County Standards\County UCS\2018 Updated County Standards\UCS 350.dwg

UNIFORM STANDARDS ALL CITIES AND COUNTY OF MARIN	TRENCH NOTES SHEET 3 OF 3			MARCH 2018
				DWG. NO.
				350
	REV.	DATE	BY	

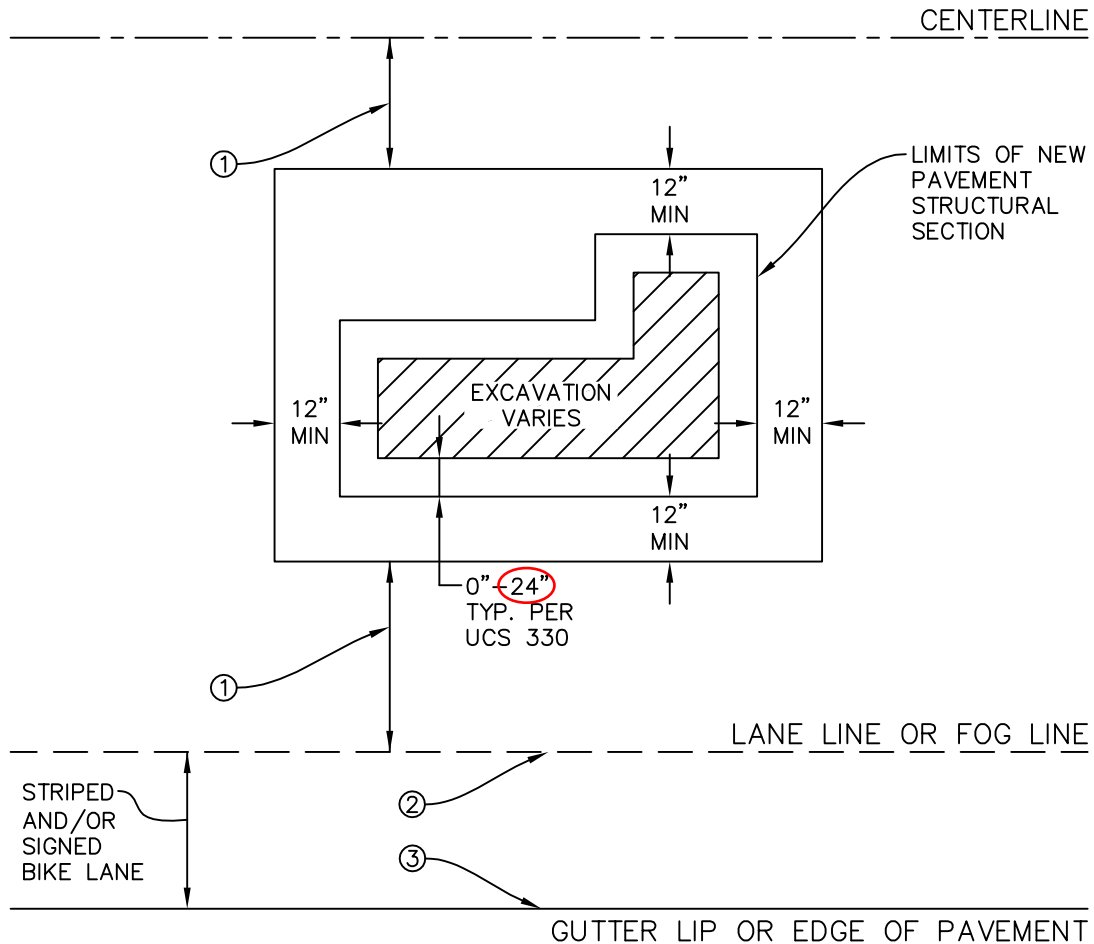

PLAN

NOTES:

- ① FOR TRENCH REPAIRS IN THE VEHICLE TRAVEL LANE(S), THE RESTORATION SHALL BE EXTENDED TO THE LANE LINE OR CENTER OF LANE WHICHEVER IS CLOSER, IN ACCORDANCE WITH MINIMUM T-CUT DIMENSIONS SHOWN ON DRAWING 330.
- ② IF THE LIMITS OF RESTORATION ENTER A STRIPED AND/OR SIGNED BIKE LANE, THE RESTORATION SHALL BE EXTENDED TO COVER THE ENTIRE BIKE LANE WIDTH.
- ③ IF THE LIMITS OF EXCAVATION ARE WITHIN 4 FT OF THE GUTTER LIP OR EDGE OF PAVEMENT, THE RESTORATION SHALL BE EXTENDED TO THE GUTTER LIP OR EDGE OF PAVEMENT.

LEGEND:

- CENTERLINE
- - - - - LINE LANE OR FOG LINE
- GUTTER LIP OR EDGE OF PAVEMENT
- DIRECTION OF TRAVEL

M:\County Standards\County UCS\2018 Updated County Standards\UCS 360.dwg

UNIFORM STANDARDS  
ALL CITIES AND  
COUNTY OF MARIN

RESTORATION  
OF ASPHALT  
SHEET 1 OF 3

			MARCH 2018
			DWG. NO.
			360
REV.	DATE	BY	

M:\County Standards\County UCS\2018 Updated County Standards\UCS 370.dwg

NOT ACCEPTABLE

ACCEPTABLE

CASE A

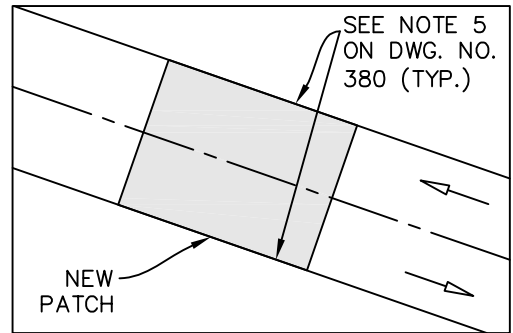
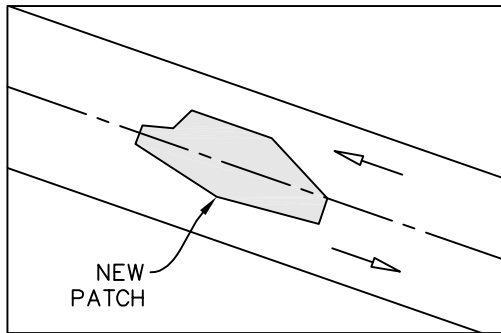

PLAN

NOTE: REFER TO DRAWING NO. 380

Full Width Restoration shall be 10' in all directions.

NOT ACCEPTABLE

ACCEPTABLE

CASE B

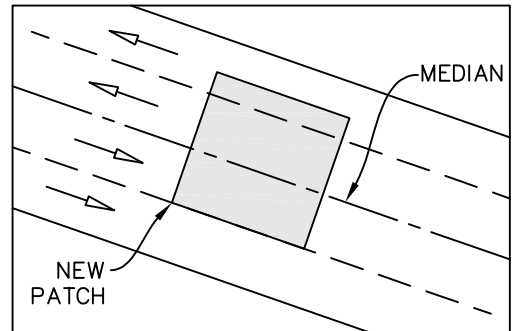
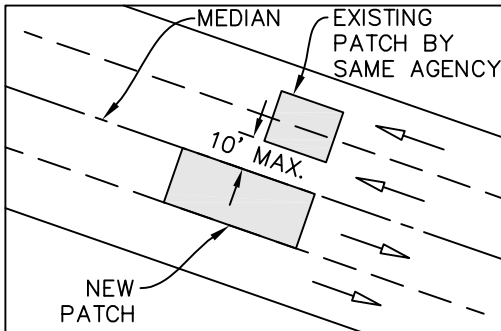

PLAN

NOTE: REFER TO DRAWING NO. 380 (NOTE 2)

NOT ACCEPTABLE

ACCEPTABLE

CASE C

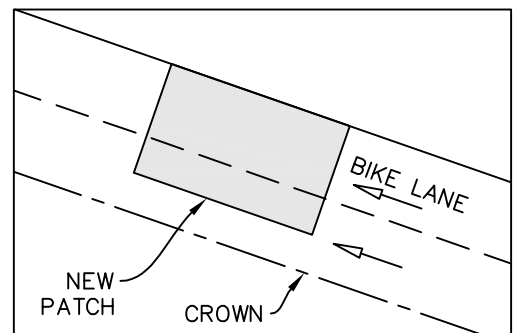
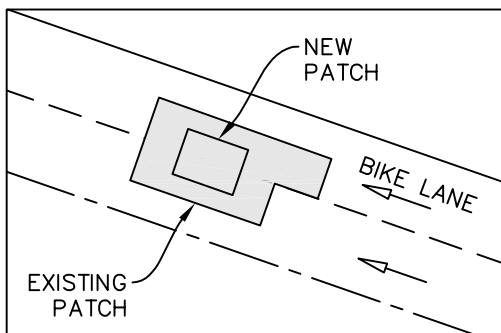

PLAN

NOTE: REFER TO DRAWING NO. 380 (NOTE 3)

NOT ACCEPTABLE

ACCEPTABLE

CASE D

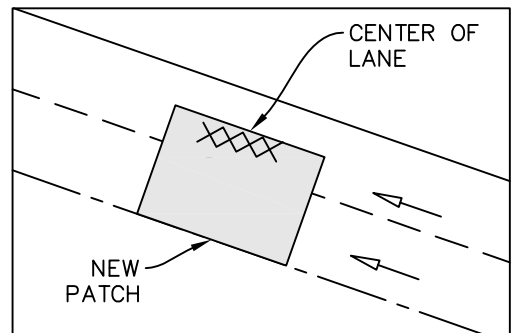
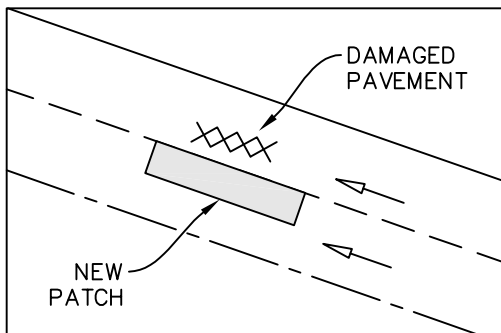

PLAN

NOTE: REFER TO DRAWING NO. 380 (NOTE 4) & NOTE 5

\*SEE DWG. NO. 360 FOR LINE TYPE LEGEND.

UNIFORM STANDARDS  
ALL CITIES AND  
COUNTY OF MARIN

RESTORATION  
OF ASPHALT  
SHEET 2 OF 3

				MARCH 2018
				DWG. NO.
				370
REV.	DATE	BY		

## RESTORATION OF ASPHALT REQUIREMENTS

**NOTES:**

- ① EXISTING PAVEMENTS SHALL BE REMOVED TO CLEAN, STRAIGHT LINES PARALLEL AND PERPENDICULAR TO THE FLOW OF TRAFFIC. DO NOT CONSTRUCT FINAL RESTORATION PATCHES WITH ANGLED SIDES AND IRREGULAR SHAPES.
- ② IF A PROPOSED CUT IS WITHIN 10 FT OF AN EXISTING PATCH ORIGINALLY PERFORMED BY THE SAME AGENCY, EXTEND THE FINAL RESTORATION TO THE EXISTING PATCH (FOR BELL HOLE OR TRENCH NO GREATER THAN 10 FT LONGITUDINAL).
- ③ IF A NEW PATCH IS DONE WITHIN AN EXISTING PATCH, THE BOUNDARIES OF THE FINAL RESTORATION FOR THE PATCHES SHALL COINCIDE.
- ④ IF A SECTION OF PAVEMENT IS DAMAGED DURING CONSTRUCTION, THE FAILED AREA SHALL BE REMOVED TO SOUND PAVEMENT AND PATCHED. IF THE DAMAGED AREA IS WITHIN 10 FT OF THE NEW PATCH, THE FINAL RESTORATION OF THE PATCHES SHALL COINCIDE.
- ⑤ LIMITS OF FINAL PAVEMENT RESTORATION TO STOP AT ONE OF THE FOLLOWING LOCATIONS: CENTER OF LANE, TRAVEL LANE LINE, BIKE LANE LINE, ISLAND CURB/GUTTER, EDGE OF ROADWAY PAVEMENT CURB/GUTTER. NO PAVING JOINTS SHALL BE ALLOWED IN A VEHICULAR WHEEL PATH.
- ⑥ STEEL PLATES USED FOR BRIDGING SHALL EXTEND A MINIMUM OF 1 FT BEYOND THE EDGE OF TRENCH. PLATES SHALL HAVE NONSKID ABRASIVE SURFACE PER CALTRANS SPECIFICATIONS 75-1.03F, AND COUNTER-SINKING MAY BE REQUIRED WHEN DEEMED NECESSARY BY AGENCY ENGINEER.
- ⑦ CUTBACK SHALL NOT BE USED EXCEPT WHEN PRE-APPROVED BY THE AGENCY ENGINEER OR WHEN TRIMMING TRENCH PLATES.
- ⑧ ROADWAY RESTORATION WIDTH, BEYOND THE TRENCH EDGES, VARIES FROM 0"-24". DURING THE PERMIT PROCESS, THE AGENCY WILL REVIEW GEOTECHNICAL AND HISTORICAL INFORMATION OF THE TRENCHING LOCATION, AS PRESENTED BY THE UTILITY OWNER, AND CONSIDER EXISTING PAVEMENT CONDITION, SUITABLE SUBGRADE AND THE PROPOSED SCOPE OF WORK TO DETERMINE RESTORATION WIDTH. THE PERMITTING AGENCY RESERVES THE RIGHT TO ADJUST THE RESTORATION WIDTH DUE TO FIELD OBSERVATIONS DURING CONSTRUCTION SUCH AS, BUT NOT LIMITED TO, OBSERVING BREAKOUT, UNDERMINING OF ADJACENT PAVEMENT, UNSTABLE WALLS OF TRENCH, DAMAGE TO SURROUNDING UNDISTURBED PAVEMENT, AND/OR PAVEMENT OR SUBGRADE DAMAGE FROM CONTRACTOR OPERATIONS.

Table A

Road Type	Traffic Index**	Min. AC*** (TOTAL)	Final Surface AC, Min.	Pavement Repair Structural Section		
				Assumes R Value = 10*		
				AC Thickness	AB Thickness	Alternate Deep Lift A.C.
Local	5.0	4"	2.0"	4.0"	7.0"	7.0"
Collector	6.5	5"	2.0"	5.0"	11.0"	11.0"
Arterial**	8.0	6"	3.0"	6.0"	14.0"	14.0"

NOTES: \*Unless applicant provides actual R-Value test results and pavement section design  
 \*\*Or as approved by City/County Engineer based on actual traffic loading  
 \*\*\*Minimum AC thickness shall math existing or as shown in Table A, whichever is greater

M:\County Standards\County UCS\2018 Updated County Standards\UCS 380.dwg

UNIFORM STANDARDS ALL CITIES AND COUNTY OF MARIN	RESTORATION OF ASPHALT SHEET 3 OF 3				MARCH 2018
					DWG. NO.
					380
		REV.	DATE	BY	