



# Downtown Form-Based Code

CHAPTER

# 9

*In this Chapter*

## **Article 1 Introduction**

**233**

**Quick Code Guide**

234

**Division 1.1 Purpose**

**236**

**1.1.010 Purpose**

236

**1.1.020 Applicability**

236

**1.1.030 Relationship to General Plan 2040 Update**

238

**1.1.040 Relationship to Downtown Precise Plan**

238

**1.1.050 Relationship to Other City Code Standards**

238

<b>Article 2 Downtown Form-Based Zones</b>	<b>243</b>
<b>Division 2.1 Preamble</b>	<b>244</b>
2.1.010 The Natural-to-Urban Transect: The Framework for Form-Based Planning and Coding	244
2.1.020 Regulating for Different Contexts	244
2.1.030 The Transect	245
2.1.040 The Transect Applied to Downtown San Rafael	245
<b>Division 2.2 Establishment and Designation of Downtown Zones</b>	<b>246</b>
2.2.010 Downtown Zones Established	246
2.2.020 Height Distinctions within Zones	246
2.2.030 Sub-Zones	247
2.2.040 Regulating Plan	247
<b>Division 2.3 Downtown Zones</b>	<b>250</b>
2.3.010 Purpose	250
2.3.020 Overview of Downtown Zones	250
2.3.030 T4 Neighborhood (T4N 30/40 and T4N 40/50)	254
2.3.040 T4 Main Street (T4MS 40/50, T4MS 40/60, T4MS 50/70, and T4MS 60/80)	260
2.3.050 T5 Neighborhood (T5N 40/60 and T5N 50/70)	266
2.3.060 T5 Main Street (T5MS 70/90)	272

<b>Article 3 Supplemental to Downtown Form-Based Zones</b>	<b>287</b>
<b>Division 3.1 Site Standards</b>	<b>288</b>
3.1.010 Purpose	288
3.1.020 Screening	288
3.1.030 Landscaping and Lighting	290
3.1.040 Parking and Loading	291
3.1.050 Block Size Standards	296
<b>Division 3.2 Massing and Facade Articulation Standards</b>	<b>298</b>
3.2.010 Purpose	298
3.2.020 Overview of Massing and Facade Articulation Standards	298
3.2.030 Tripartite Facade Articulation	299
3.2.040 Massing and Composition	300
3.2.050 Corner Elements	302
3.2.060 Windows and Openings	304
<b>Division 3.3 Frontage Standards</b>	<b>308</b>
3.3.010 Purpose	308
3.3.020 Overview of Frontage Types	308
3.3.030 Porch Projecting	312
3.3.040 Porch Engaged	313

<b>3.3.050</b> Dooryard	314
<b>3.3.060</b> Stoop	315
<b>3.3.070</b> Forecourt	316
<b>3.3.080</b> Maker Shopfront	317
<b>3.3.090</b> Shopfront	318
<b>3.3.100</b> Terrace	319
<b>3.3.110</b> Gallery	320

## **Article 4 Definitions** **323**

<b>Division 4.1 Definitions</b>	<b>324</b>
<b>4.1.010</b> Definitions	324
<b>4.1.020</b> Use Types	331
<b>4.1.030</b> Measurement Methods	338

*This page intentionally left blank*

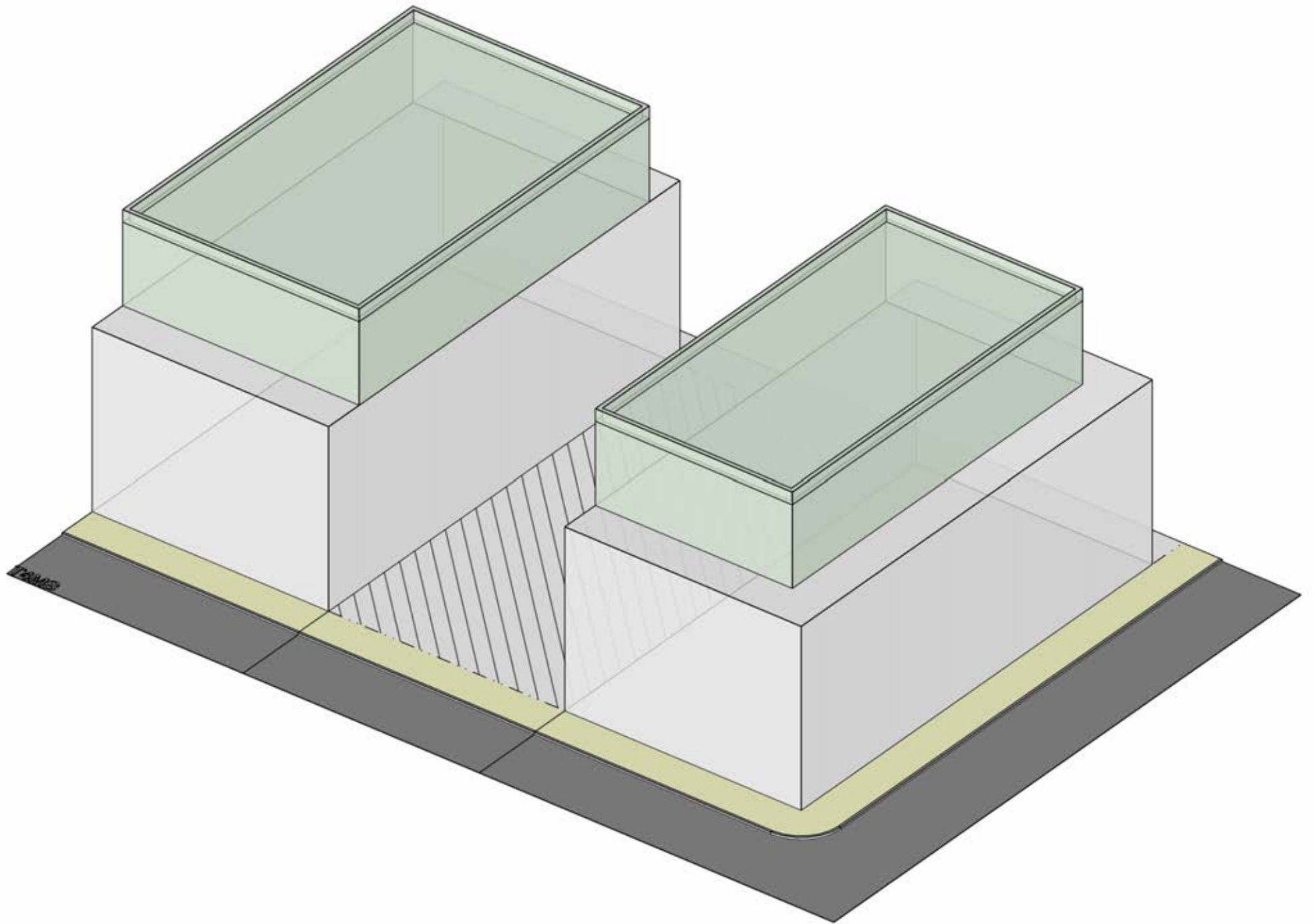

# Introduction

ARTICLE

1

## Quick Code Guide



**Note:** *this diagram is intended to provide a simplified overview of the code's requirements and is descriptive, not regulatory.*





# Division 1.1 Purpose

## 1.1.010 Purpose

This Downtown Form-Based Code (DTFBC) is enacted for three key purposes:

- To implement the vision described in the Downtown Precise Plan (Plan) for a variety of urban neighborhoods and main street environments;
- To provide the community with a clear understanding of what the code requires and what it allows and generates regarding physical form, character and uses; and
- To streamline the review and processing of development projects through the codes' coordination with the Plan and through its clarity of standards and expectations.

## 1.1.020 Applicability

### Rules of Construction

The following general rules of construction apply to the text of this Chapter:

**Terminology: shall, may and should.** "Shall" is always mandatory and not permissive. "May" is permissive. "Should" is advisory and identifies guidance provided by the City in implementation of these standards.

**Tenses and Numbers.** Words used in the present tense include the future, words used in the singular include the

plural, and the plural includes the singular, unless the context clearly indicates the contrary.

**Applicable.** The applicable standards of Chapter Nine (Downtown Form-Based Code) are acknowledged to apply so as to not require stating the phrase "and all applicable standards" throughout.

**Conjunctions.** Unless the context clearly indicates otherwise, the following conjunctions shall be interpreted as follows:

- "And" indicates that all connected items or provisions apply;
- "Or" indicates that the connected items or provisions may apply; and
- "Either/or" indicates that the connected items or provisions apply singly but not in combination.

**Relevance.** In form-based zones, the standards in Chapter Nine (Downtown Form-Based Code) prevail unless stated otherwise.

### Applicability of Standards

The standards in Chapter Nine (Downtown Form-Based Code) apply to all proposed development and improvements within form-based zones as identified below.

**Non-Conformities.** See San Rafael Municipal Code (SRMC) Section 14.16.270 (Nonconforming Structures

and Uses) for when the standards of the Chapter Nine (Downtown Form-Based Code) apply.

**New Development.** New development, additions and renovations are required to be designed per the zone standards identified for the parcel(s) in DTFBC Figure 2.2.040.A (Regulating Plan).

#### **Blocks and Streets**

- Development sites larger than two acres shall be divided into new blocks in compliance with DTFBC Table 3.1.050.A (Block Size Standards).
- Development sites larger than two acres are required to include new streets including any required in the approximate locations identified on the DTFBC Figure 2.2.040.A (Regulating Plan) in compliance with Chapter Six (Transportation and Parking).
- When designing a new street or retrofitting an existing street, the guidelines in Chapter Six (Transportation and Parking) apply.

**New Buildings.** New buildings and their additions are required to be designed in compliance with the building placement and size standards of the zone.

**General.** From the allowed types in the zone, and in compliance with the listed standards, the following shall be selected for each lot:

- At least one frontage type for each street or civic space frontage; and
- At least one use type.

Frontage types not listed in the zone's standards are not allowed in that zone.

Use types not listed in the DTFBC Table 2.3.070.A (Use Table) are not allowed in that zone except as set forth in SRMC Section 14.02.040.B (Land Use Categories).

**Site Standards.** When a development requires approval in compliance with SRMC Title 14 (Zoning), the standards of this Sub-Section apply to the following:

**Screening.** The standards of DTFBC Section 3.1.020 (Screening) apply to the following:

- All new development; and
- Improvements to existing development.

**Landscaping and Tree Standards.** The standards of DTFBC Section 3.1.030 (Landscaping) apply to the following:

- All new development; and
- Improvements to existing development.

**Parking and Loading.** The requirements of DTFBC Sub-Section H (Parking) of the zone standards apply to the following, except as superseded by other City ordinances regarding affordable housing:

- New development;
- Changes in intensity or uses of buildings or structures made after the effective date of this Article that cause an increase of 25 percent or greater in:
  - Gross floor area over 5,000 sf;
  - Seating capacity;
  - Units; and/or
  - Parking spaces.

#### **Civic Space Standards**

- New buildings or additions are required to include civic space as identified in DTFBC Sub-Section C (Building Placement) of the zone.
- Development sites larger than two acres are required to create new civic space(s) in the approximate locations identified on the DTFBC Figure 2.2.040.A (Regulating Plan) in compliance with the standards of DTFBC Civic Space in Sub-Section C of the zone.

**Massing, Facade Articulation and Architectural Elements.**

The standards of DTFBC Division 3.2 (Massing and Facade Articulation Standards) apply to the following:

- New building; and
- Building facade renovation facing a street or civic space (except public safety buildings).

**Frontage Standards.** The standards of DTFBC Division 3.3 (Frontage Standards) apply to the following:

- New building;
- Building facade renovation facing a street or civic space (except public safety buildings);
- Private property improvement along front or side street; and
- Modification of pedestrian entrance(s) along front or side street.

**Signage Standards.** See SRMC Chapter 14.19 (Signs) for signage standards and processing requirements.

**1.1.030 Relationship to General Plan 2040 Update**

Chapter Nine (Downtown Form-Based Code) of the Plan is a refinement of the community vision and intent in the General Plan 2040 Update (General Plan) for the parcels and rights-of-way within the Plan boundaries.

Chapter Nine (Downtown Form-Based Code) implements the City's General Plan vision within the boundaries of the Plan to implement the General Plan direction for a variety of walkable environments. Walkable is described as an environment that is pedestrian-oriented in nature, where bicycling and walking are viable daily options because services, retail, or restaurants are within a short walking distance of most dwellings.

**1.1.040 Relationship to Downtown Precise Plan**

Chapter Nine (Downtown Form-Based Code) of the Plan implements the Plan's updated community vision and intent for the parcels and streets within the Plan boundaries. In the event of a conflict the standards of this Chapter shall apply.

**1.1.050 Relationship to Other City Code Standards**

The standards described in this Chapter prevail over existing standards unless specifically stated otherwise in Table 1.1.040A. All parcels covered by the Downtown Form Based Code are considered to be in the Downtown Mixed Use (DMU) Zone District and are referenced as such in other parts of the San Rafael Municipal Code.

<b>Table 1.1.040.A Relationship to California Fire Code, SRMC Title 2 (Administration), SRMC Title 14 (Zoning), and SRMC Title 19 (Open Space)</b>		
<b>Division/ Chapter/ Section</b>	<b>Description</b>	<b>Status</b>
<b>California Fire Code</b>		
Chapter 5: Section 503 and Appendix D, Section 504, Section 505, Section 507 and Section 509	Fire Service Features	Chapter Nine (Downtown Form-Based Code) relies on Chapter 5 (Five Service Features)
<b>SRMC Title 2 (Administration)</b>		
Chapter 2.18	Historic Preservation	Chapter Nine (Downtown Form-Based Code) relies on SRMC Chapter 2.18
<b>SRMC Title 14 (Zoning)</b>		
Division II	Base District Regulations	Replaced by form-based zones within the Plan boundaries.
Division III	Overlay District Regulations	Replaced by form-based zones within the Plan boundaries.
Division V	Administrative Regulations	Chapter Nine (Form-Based Zones Code) relies on SRMC Division V (Administrative Regulations).
Chapter 14.03	Definitions	DTFBC Division 4.1 (Definitions) adds definitions to SRMC Chapter 14.03 (Definitions) only within the Plan boundaries.
Chapter 14.17	Performance Standards	Chapter Nine (Downtown Form-Based Code) relies on SRMC Chapter 14.17 (Performance Standards).
Chapter 14.18	Parking Standards	SRMC Table 14.18.040 (Parking Requirements) replaced by Chapter Nine (Downtown Form-Based Code) within the Plan boundaries. All other standards of SRMC Chapter 14.18 (Parking Standards) apply.
Chapter 14.19	Signs	Chapter Nine (Downtown Form-Based Code) relies on SRMC Chapter 14.19 (Signs).
Section 14.16.270	Non-Conforming Structures and Uses	Chapter Nine (Downtown Form-Based Code) relies on SRMC Section 14.16.270 (Non-Conforming Structures and Uses).
Section 14.16.295	Sight Distance	SRMC Section 14.16.295 (Sight Distance) does not apply within the Plan boundaries.
Sections 14.16.243 and 14.18.160	Screening Standards	Chapter Nine (Downtown Form-Based Code) replaces SRMC Sections 14.16.243 (Mechanical Equipment Screening) and 14.18.160 (Parking Lot Screening and Landscaping) within the Plan boundaries.
Sections 14.18.170, 14.16.227, and 14.19.055	Outdoor Lighting Standards	Chapter Nine (Downtown Form-Based Code) relies on SRMC Sections 14.18.170 (Lighting), 14.16.227 (Light and Glare) , and 14.19.055 (Illumination Standards).
Tables 14.04.020, 14.05.020, 14.05.022, 14.08.030, 14.09.020, 14.10.020 and Section 14.07.020	Land use regulations	DTFBC Table 2.3.070.A (Use table) replaces SRMC Title 14 (Zoning) Use Tables within the Plan boundaries. All other standards of Division II apply.
<b>SRMC Title 19 (Open Space)</b>		
Chapter 19.10	Land and Water Areas	Chapter Nine (Downtown Form-Based Code) relies on SRMC Title 19 (Open Space).

### 1.1.060 Permit Required

New buildings, renovations, additions, and signage require City approval as identified in DTFBC Table 1.1.060.A (Permit Requirements). Please refer to SRMC Title 14 (Zoning) for permit application requirements and

procedures. For projects involving a historic resource, refer to SRMC Chapter 2.18 (Historic Preservation).

Table 1.1.060.A Permit Requirements				
Application	Permit Required			
	Administrative Environmental and Design Review Permit	Minor Environmental and Design Review Permit	Major Environmental and Design Review Permit	Certificate of Appropriateness
Alteration to Historic Resource	-	-	•	•
Renovation/ expansion < 50% of existing building	•	-	-	-
Renovation/ expansion > 50% of existing building	-	•	-	-
New building up to 30' overall height	-	•	-	-
With height bonus up to 40' overall height	-	•	-	-
New building up to 40' overall height	-	•	-	-
With height bonus up to 50' overall height	-	-	•	-
New building up to 40' overall height	-	•	-	-
With height bonus up to 60' overall height	-	-	•	-
New building up to 50' overall height	-	-	•	-
With height bonus up to 70' overall height	-	-	•	-
New building up to 60' overall height	-	-	•	-
With height bonus up to 80' overall height	-	-	•	-
New building up to 70'	-	-	•	-
With height bonus up to 90' overall height	-	-	•	-

Table 1.1.060.A Permit Requirements (Continued)				
Application	Permit Required			
	Administrative Environmental and Design Review Permit	Minor Environmental and Design Review Permit	Major Environmental and Design Review Permit	Certificate of Appropriateness
Development of site > 2 acres	-	-	•	-
Alteration adjacent to a historic resource in compliance with SRMC Section 2.18.065 (Development Standards)	•	-	-	-
Alteration adjacent to a historic resource not in compliance with SRMC Section 2.18.065 (Development Standards)	-	-	•	-

For Minor and Major Environmental and Design Review, see SRMC Section 14.25. Major review applies to “major physical improvements” [see 14.25.040 (A)] and Minor review applies to “minor physical improvements” [see 14.25.040 (B)]. See also Administrative Design Review process for smaller projects.

For review criteria for Major and Minor Environmental and Design Review, see SRMC Section 14.25.050; and Section 14.25.060 for hearing/public review requirements. Minor Review is done in a public hearing convened by the Zoning Administrator and Major Review is performed by the Planning Commission.

For Permanent Sign see SRMC Section 4.19.041 (Sign Permit Required).







# Downtown Form-Based Zones

ARTICLE

# 2

# Division 2.1 Preamble



## 2.1.010 The Natural-to-Urban Transect: The Framework for Form-Based Planning and Coding

The Natural-to-Urban Transect is an organizing principle used in Form-Based planning and coding that establishes a hierarchy of places/ contexts from the most natural to the most urban. The designation of each transect along this hierarchy is determined first by the character and form, intensity of development, and type of place and secondly by the mix of uses within the area. This hierarchy of places becomes the framework or organizing principle for the entire plan and code, replacing use as the organizing principle as is used in conventional or Euclidean zoning. Transect zones are used to reinforce existing or to create new walkable mixed-use urban environments.

*“The Natural-to-Urban Transect is a means for considering and organizing the human habitat in a continuum of intensity that ranges from the most rural condition to the most urban. It provides a standardized method for differentiating between the intentions for urban form in various areas using gradual transitions rather than harsh distinctions. The zones are primarily classified by the physical intensity of the built form, the relationship between nature and the built environment, and the complexity of uses within the zone.”*

~ Form-Based Codes Institute

The model transect for American towns is divided into six transects: Natural (T1), Rural (T2), Sub-Urban (T3), General Urban (T4), Urban Center (T5), and Urban Core (T6), together with a District (D), often referred to as a Special District, a designation for areas with specialized purposes (e.g., heavy industrial, transportation, entertainment, or university districts, among other possibilities). Each transect is given a number. Higher numbers designate progressively more urban environments, and lower numbers designate more rural environments.

For additional information visit the Form-Based Codes Institute website at [www.formbasedcodes.org](http://www.formbasedcodes.org)

## 2.1.020 Regulating for Different Contexts

The Form-Based Code applies a community-character-based approach to zoning that is based upon the classification of three distinct context types. Each context type—Natural, Walkable, and Auto-Oriented Suburban—needs to be regulated differently in order to effectively reinforce the intended context.

**Natural Context Type** consists of land not intended for development. In these areas, nature dominates a person's experience, but may include an occasional recreation-oriented or utility building or other man-made feature. The use of cars is integrated, but does not dominate the physical character. These areas are implemented through conventional, use-based zones.

**Auto-Oriented Suburban Context Type** consists of areas developed mainly after the 1950's. In this context type land uses are segregated and often buffered, leaving large distances between them contributing to the need for the automobile for day-to-day functions. Walking and cycling occur in these areas, but generally for recreational purposes due to low connectivity. These areas are implemented through conventional, use-based zones.

**Walkable Context Type** consists of areas where a person can walk, bicycle or ride transit to work to fulfill most shopping and recreation needs. These areas allow for but do not require the use of a vehicle to accommodate most daily needs. These areas were primarily developed prior to the 1940's in a pattern where a person can live with limited reliance on the automobile. Today, these areas are still conducive to destination walking and cycling and supported through public transit, a network of interconnected, tree-lined streets, a diversity of housing choices, and a mix of appropriate commercial and residential uses in a compact form. These areas are implemented through the T3-T5 form-based zones.

**2.1.030 The Transect**

Each of the six transects is implemented by form-based zones (Zones) as illustrated in DTFBC Figure 2.1.030.A (The Transect). The zones needed to implement the transect for Downtown San Rafael are identified with the highlighted purple.

**2.1.040 The Transect Applied to Downtown San Rafael**

To enhance Downtown's San Rafael current walkable character, this Form-Based Code applies transect zones related to the Walkable Context Type (i.e., T4 and T5 Neighborhood and Main Street). In this way, this FBC enables distinct walkable development patterns that are based on interconnected streets and blocks, variety of housing choices, and proximity to services, shopping and/or transit.

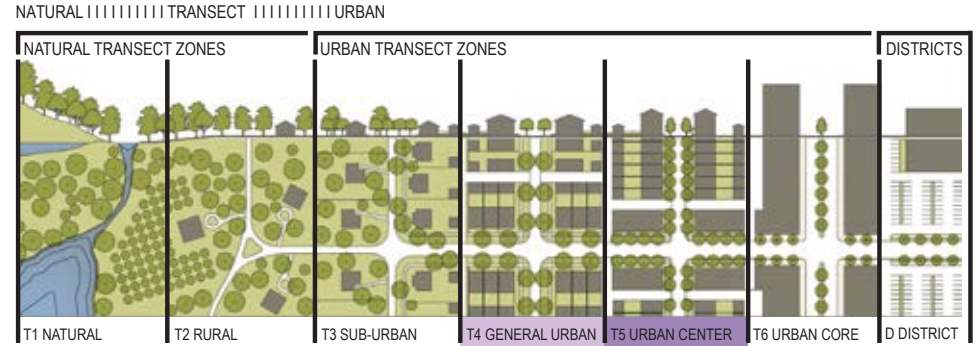

Figure 2.1.030.A The transect



Figure 2.1.040.A The Transect applied to Downtown San Rafael.

# Division 2.2 Establishment and Designation of Downtown Zones

## 2.2.010 Downtown Zones Established

**Form-Based Zones and Standards.** This Section describes the form-based zones and standards. Each zone is established based on the intended physical form and character of the environments described in the Plan. These zones focus on mixed-use, walkable environments and range in function and intensity:

**Moderate intensity neighborhoods:**

- T4 Neighborhood T4N 30/40 (Section 2.3.030)
- T4 Neighborhood T4N 40/50 (Section 2.3.030)

**A community-serving Downtown:**

- T4 Main Street T4MS 40/50 (Section 2.3.040)
- T4 Main Street T4MS 40/60 (Section 2.3.040)
- T4 Main Street T4MS 50/70 (Section 2.3.040)
- T4 Main Street T4MS 60/80 (Section 2.3.040)

**High intensity neighborhoods:**

- T5 Neighborhood T5N 40/60 (Section 2.3.050)
- T5 Neighborhood T5N 50/70 (Section 2.3.050)

**A regional-serving transit center and main street:**

- T5 Main Street T5MS 70/90 (Section 2.3.060)

The naming of the form-based zones is based on a spectrum of context types in the City from less urban to more urban as listed in Table 2.3.020.A (Downtown Zones Overview).

## 2.2.020 Height Distinctions within Zones

Height bonuses listed below and shown on the Regulating Plan may only be used in lieu of those allowed under State Density Bonus law for qualifying projects. The bonuses allowed by the form-based zones may not be added to or combined with State Density Bonuses. The maximum height allowed per zone is identified on the Regulating Plan as a suffix to the zone name. For example, the T4N 40/50 allows up to 40' base height and up to 50' with a bonus. See DTFBC Table 2.2.020.A (Height Distinctions per Zone).

**Table 2.2.020.A Height Distinctions per Zone**

Zone	Base Height (Overall)	With Height Bonus (Overall)
T4 Neighborhood		
T4N 30/40	30' max.	40' max.
T4N 40/50	40' max.	50' max.
T4 Main Street		
T4MS 40/50	40' max.	50' max.
T4MS 40/60	40' max.	60' max.
T4MS 50/70	50' max.	70' max.
T4MS 60/80	60' max.	80' max.
T5 Neighborhood		
T5N 40/60	40' max.	60' max.
T5N 50/70	50' max.	70' max.
T5 Main Street		
T5MS 70/90	70' max.	90' max.

### 2.2.030 Sub-Zones

Sub-zones are slight variations of the base zone, lot-specific, and mapped on DTFBC Figure 2.2.040.A (Regulating Plan). This Article includes two types of sub-zones:

**Open.** The open sub-zone is applied for either or both of the following purposes:

- To allow more uses than the base zone allows in specific areas but within the same form and character of the base zone; and/or
- To more easily allow certain uses that are already allowed in the base zone. In addition in this way, the open sub-zone can provide additional flexibility to lots located at or near intersections that function or can function as a neighborhood node of non-residential uses.

### 2.2.040 Regulating Plan

The zones established in this Article are mapped on DTFBC Figure 2.2.040.A (Regulating Plan). In addition to identifying the zoning for each lot, DTFBC Figure 2.2.040.A (Regulating Plan) identifies specific urban design requirements and height limitations based on location and intended physical character.

Where DTFBC Figure 2.2.040.A (Regulating Plan) identifies two zones on one parcel, the boundary of each shall be

determined by a minimum depth of 100 feet measured perpendicular to the adjacent right-of-way or civic space from the midpoint of the lot width. In cases where the block depth is inadequate to support this measurement, zone boundaries may be adjusted during the project review process. As a general rule boundaries of adjacent parcels must be considered in boundary identification and adjustment during the review process.

When a project combines multiple parcels from two or more zones, the zone boundaries shown on Figure 2.2.040.A (Regulating Plan) may be modified to accommodate the new parcel boundary but shall not result in new zones to be added to the parcel. This boundary adjustment is subject to Director review and approval unless referred to the Planning Commission.

The front of a parcel is assumed to be along the primary abutting street. In situations where parcels abut two primary streets (such as corner parcels, parcels in the West End between Second and Fourth Street, etc.), both primary street frontages should be treated as the front with applicable standards. Alternately, the determination of the front of such parcels shall be made by the Director.

Figure 2.2.040.A Regulating Plan. Note this is the same map as Figure 4.5 in Chapter Four: Design Vision

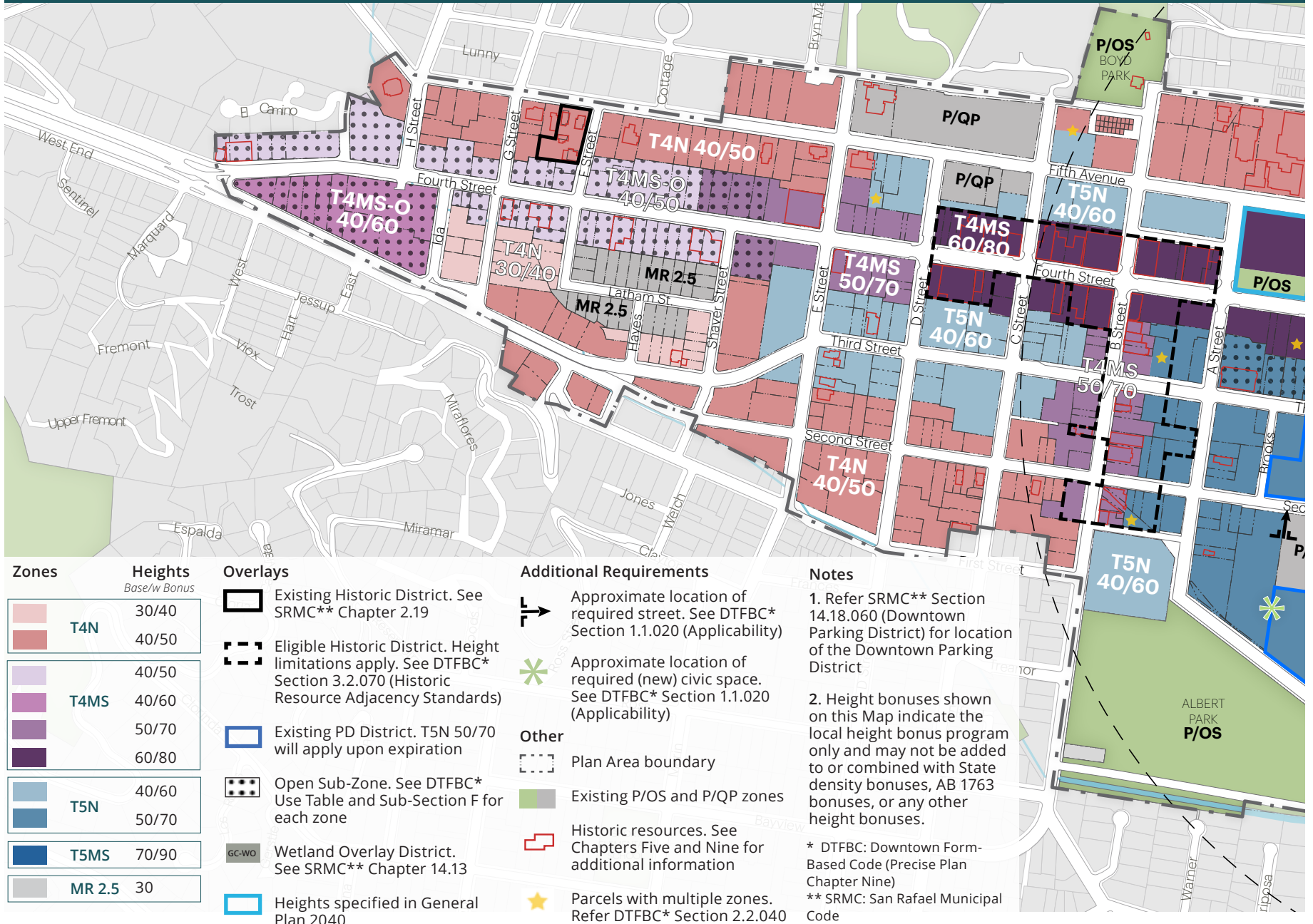
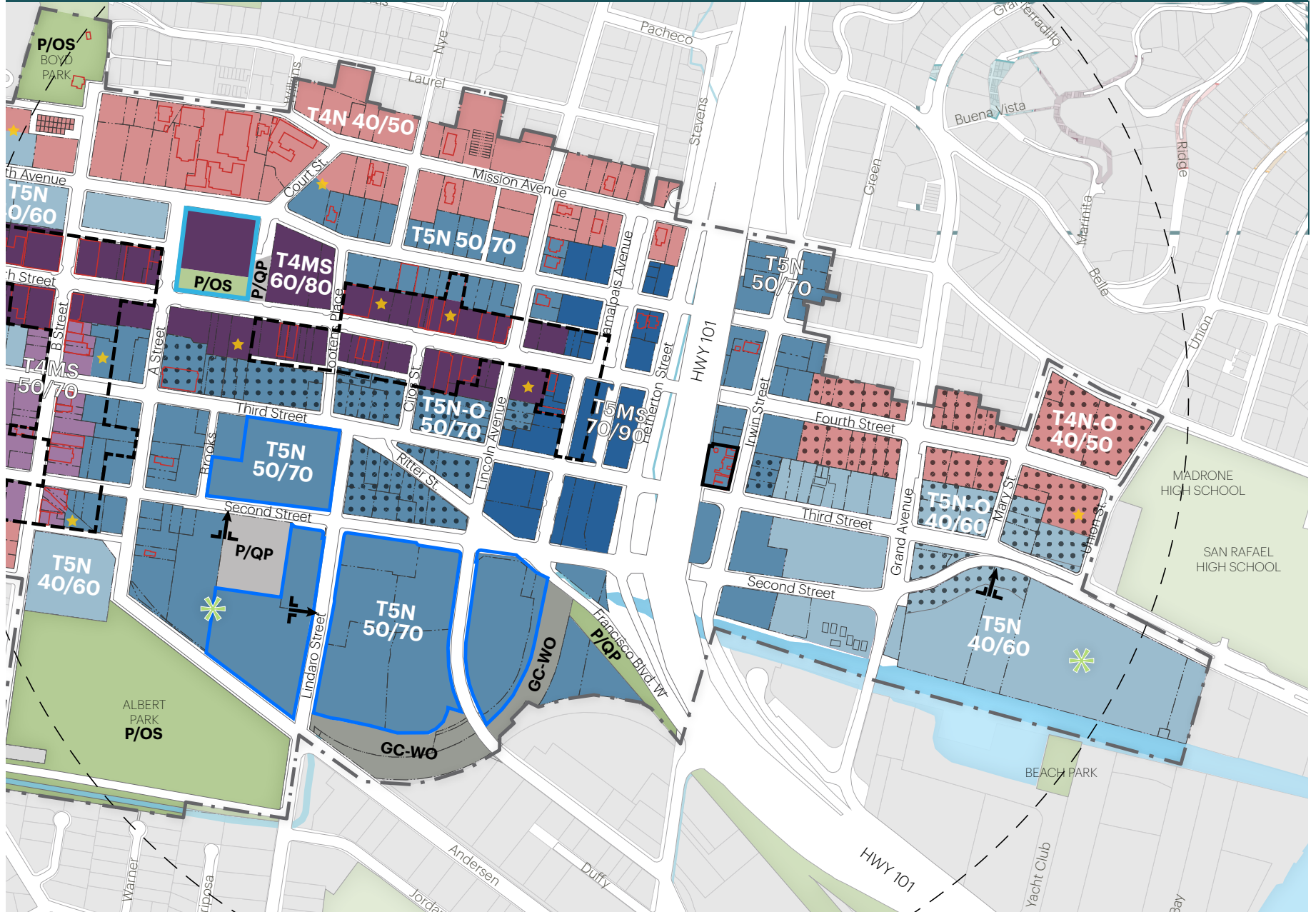

Figure 2.2.040.A Regulating Plan (Continued) Note this is the same map as Figure 4.5 in Chapter Four: Design Vision



# Division 2.3 Downtown Zones

## 2.3.010 Purpose

This Division establishes the palette of form-based zones to implement the Plan by generating and supporting the intended physical form and character and range of uses.

## 2.3.020 Overview of Downtown Zones

DTFBC Table 2.3.020.A (Downtown Zones Overview) provides an overview of each zone and its intent. This information is provided as background on the intended physical character, allowed range of uses, and direction for the detailed standards in each zone.

Following the Overview, each of the Downtown Zones and its standards begin at DTFBC Section 2.3.030 T4 Neighborhood (T4N 30/40 and T4N 40/50).

Collectively, the Downtown Zones comprise the Downtown Mixed Use (DMU) district, as referenced in Chapter 14 of the San Rafael Municipal Code.



*This page intentionally left blank*

**Table 2.3.020.A Downtown Zones Overview**



**T4 Neighborhood**



**Zone Abbreviation**

T4N 30/40 and T4N 40/50

**Sub-Zone(s)**

T4N 40/50 Open

The open sub-zone allows more uses, additional signage and sometimes additional frontages, within the same form and character of the base zone.

**Intent**

A walkable neighborhood environment of small-to-medium footprint, moderate-intensity mixed-use buildings and housing choices, supporting and within short walking distance of neighborhood-serving retail and services. This zone provides a transition in scale between the Downtown and adjacent residential neighborhoods.

**Desired Form**

- Primarily House-Form Buildings

---

- Building Height 30' to 50', as per Regulating Plan

---

- Primarily Detached Buildings

---

- Small Front Setbacks

---

- Small Side Setbacks

---

- Residential and Shopfront Frontages

**T4 Main Street**



**Zone Abbreviation**

T4MS 40/50, T4MS 40/60, T4MS 50/70, and T4MS 60/80

**Sub-Zone(s)**

T4MS 40/50 Open, T4MS 40/60 Open and T4MS 50/70 Open

The open sub-zone allows more uses, additional signage and sometimes additional frontages, within the same form and character of the base zone.

**Intent**

A walkable, vibrant district of medium-to-large footprint, moderate intensity, mixed-use buildings and housing choices, supporting neighborhood and community-serving ground floor shopping, food and services, including civic, institutional, maker/ craft/ artisan businesses (both indoor and outdoor).

**Desired Form**

- Primarily Block-Form Buildings

---

- Building Height 40' to 80', as per Regulating Plan

---

- Attached Buildings

---

- Small-to-No Front Setbacks



---

- No Side Setbacks

---

- Predominantly Shopfront Frontages

**Table 2.3.020.A Downtown Zones Overview (Continued)**

		More Urban 
<p><b>T5 Neighborhood</b></p>  <p><b>Zone Abbreviation</b> T5N 40/60 and T5N 50/70</p> <p><b>Sub-Zone(s)</b> T5N 40/60 Open and T5N 50/70 Open The open sub-zone allows more uses, additional signage and sometimes additional frontages, within the same form and character of the base zone.</p> <p><b>Intent</b> A walkable neighborhood environment of large footprint, high-intensity mixed-use buildings, supporting and within short walking distance of neighborhood shopping, services, and transit.</p> <p><b>Desired Form</b> Primarily Block-Form Buildings Building Height 40' to 70', as per Regulating Plan Primarily Attached Buildings Small-to-No Front Setbacks Small-to-No Side Setbacks Residential and Shopfront Frontages</p>	<p><b>T5 Main Street</b></p>  <p><b>Zone Abbreviation</b> T5MS</p> <p><b>Sub-Zone(s)</b> None</p> <p><b>Intent</b> A walkable, urban neighborhood environment with large footprint, high-intensity mixed-use buildings in close proximity to the multimodal transit station, with neighborhood-serving shopping and services.</p> <p><b>Desired Form</b> Primarily Block-Form Buildings Building Height 70' to 90' Attached Buildings Small-to-No Front Setbacks No Side Setbacks Predominantly Shopfront Frontages</p>	

**Note:**  
The standards for each zone begin on the following page.

### 2.3.030 T4 Neighborhood (T4N 30/40 and T4N 40/50)



#### A. Intent

A walkable neighborhood environment of small-to-medium footprint, moderate-intensity mixed-use buildings and housing choices, supporting and within short walking distance of neighborhood-serving retail and services. This zone provides a transition in scale between the Downtown and adjacent residential neighborhoods.

#### B. Sub-Zone(s)

T4N 40/50 Open. The open sub-zone allows more uses, additional signage and sometimes additional frontages, within the same form and character of the base zone.

The following are generally appropriate form elements in the zone.

- Primarily House-Form Buildings **A**
- Building Height 30' to 50', as per Regulating Plan **B**
- Primarily Detached Buildings **C**
- Small Front Setbacks **D**
- Small Side Setbacks **E**
- Porch Projecting, Porch Engaged, Dooryard, Stoop, Maker Shopfront, Shopfront, Terrace Frontage Types **F**

C. Building Placement	
Setback (Distance from ROW/ Lot Line)	
Front (Facade Zone)	7' min.; 15' max. <b>G</b>
Side Street (Facade Zone)	7' min.; 15' max. <b>H</b>
Total length of facade required within or abutting the Facade Zone, exclusive of setbacks <sup>1</sup>	
Front	70% min.
Side Street	50% min.
Side	5' min. <b>I</b>
Rear <sup>2</sup>	15' min. <b>J</b>
Footprint	
Building Length	75' max.
Civic Space	
Site Size (sf) or Lot Width	Required Area (min.)
15,000 to 30,000 or 100'-150'	200 sf
> 30,000 or 150'-250'	1,000 sf
Lot Width >250'	5% of Site

<sup>1</sup> Facades facing a street or civic space shall be designed in compliance with DTFBC Division 3.2 (Massing and Facade Articulation Standards).

<sup>2</sup> See Sub-Section G (Adjacency Standards) of this Section for additional refinements.

D. Encroachments <sup>1</sup>				
Encroachment Type	Front	Side St.	Side	Rear
Frontage Types <sup>2</sup>	A	A	X	A
Steps to Building Entry	5' max.	5' max.	3' max.	5' max.
Canopies/ Overdoors, Signage <sup>3</sup>	3' max.	3' max.	2' max.	3' max.
Balconies, Unenclosed Porches, Bay Windows <sup>3</sup>	5' max.	5' max.	2' max.	5' max.

**Key**                      A = Allowed                      X = Not Allowed



**Key**

- ROW/ Lot Line
- Buildable Area
- Building Setback Line
- ▨ Facade Zone

D. Encroachments <sup>1</sup> (Continued)				
Encroachment Type	Front	Side St.	Side	Rear
Corner Elements	3' min. to 5' max.	n/a	n/a	n/a

<sup>1</sup> Includes encroachments into building setbacks and facade zone.

<sup>2</sup> See Sub-Section F (Frontages) of this Section for allowed types and standards.

<sup>3</sup> May also encroach into required stepbacks.

E. Building Form and Maximum Envelope		
Height	Base	Height Bonus <sup>1</sup>
<b>Overall Building Height<sup>2,3,4</sup></b>		
T4N 30/40	30' max. 40' max.	<b>K</b>
T4N 40/50 and T4N 40/50 Open	40' max. 50' max.	<b>K</b>
<b>Highest Top Plate/ Highest Eave Measurement</b>		
T4N 30/40	25' max. 35' max.	<b>L</b>
T4N 40/50 and T4N 40/50 Open	35' max. 45' max.	<b>L</b>
<b>Stepback<sup>5</sup></b>		
<b>T4N 30/40</b>		
Front	10' min. at 25'	<b>M</b>
Side Street	10' min. at 25'	<b>N</b>
Rear	10' min. at 25'	<b>O</b>
<b>T4N 40/50 and T4N 40/50 Open</b>		
Front	10' min. at 35'	<b>M</b>
Side Street	10' min. at 35'	<b>N</b>
Rear	10' min. at 35'	<b>O</b>
<b>Ground Floor Standards</b>		
Ground Floor Finish Level		<b>P</b>
Residential <sup>6</sup>	12" min.	
Non-Residential <sup>7</sup>	Flush with Sidewalk	
Ground Floor Ceiling	9' min.	<b>Q</b>
Depth, Ground-Floor Space	30' min. front; 12' min. other	<b>R</b>

<sup>1</sup> See SRMC Section 14.16.190 (Height Bonus) for requirements to qualify for height bonus.

<sup>2</sup> See DTFBC Figure 2.2.040.A (Regulating Plan) for further refinements.

<sup>3</sup> Corner elements may exceed the maximum allowed height by up to 10' for a horizontal area up to 20' x 20'.

### E. Building Form and Maximum Envelope (Continued)

<sup>4</sup> See SRMC Section 14.16.120 (Exclusions to the Maximum Height Requirement) for exclusions to the overall building height.

<sup>5</sup> Stepback not required when the uppermost floor and up to two floors including the uppermost floor are within a mansard roof. See DTFBC Section 3.2.060 (Windows and Openings).

<sup>6</sup> Common entries may be set at grade in compliance with local and federal accessibility standards.

<sup>7</sup> Or as required to comply with FEMA base flood elevation.

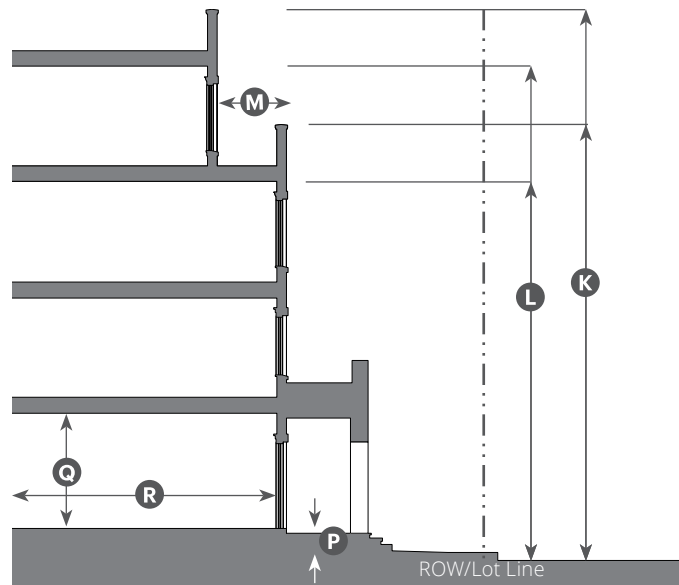

Maximum Envelope in Mid-Block and Corner Condition

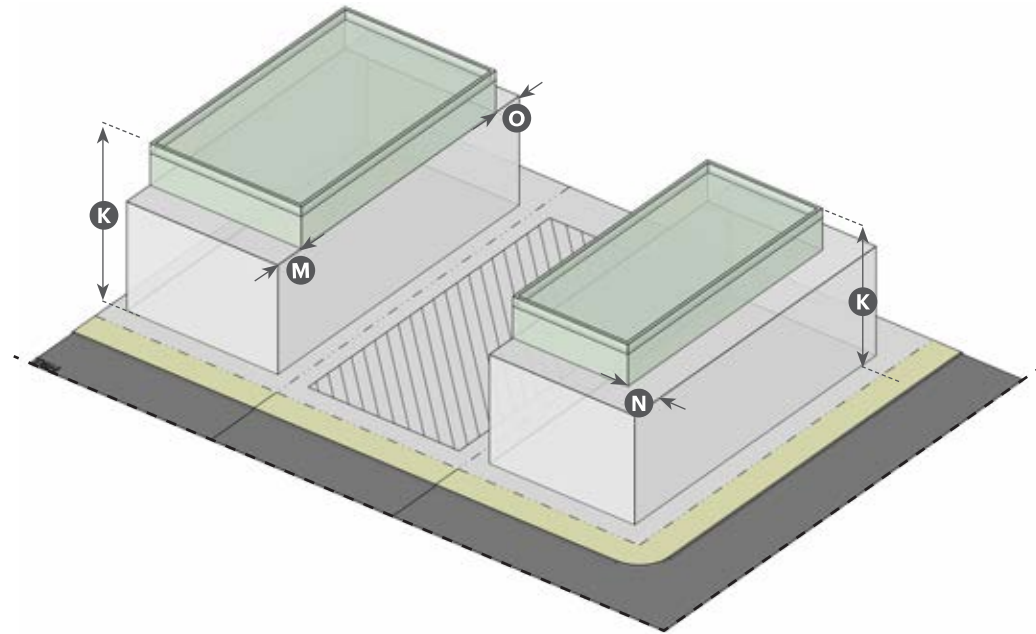

**F. Frontages<sup>1</sup>**

Frontage Type	Front	Side St.	Standards
Porch Projecting	A	A	3.3.030
Porch Engaged	A	A	3.3.040
Dooryard	A	A	3.3.050
Stoop	A	A	3.3.060
Maker Shopfront	A <sup>2</sup>	A <sup>2</sup>	3.3.080
Shopfront	A <sup>2</sup>	A <sup>2</sup>	3.3.090
Terrace	A	A	3.3.100

<sup>1</sup> Minimum of one Frontage Type per street-facing facade.

<sup>2</sup> Only in Open Sub-Zone.

**Key** A = Allowed

**Key**

- Max. Envelope without Height Bonus (Base)
- Max. Envelope with Height Bonus
- Street Centerline

**Adjacent to HR1 and R/O**

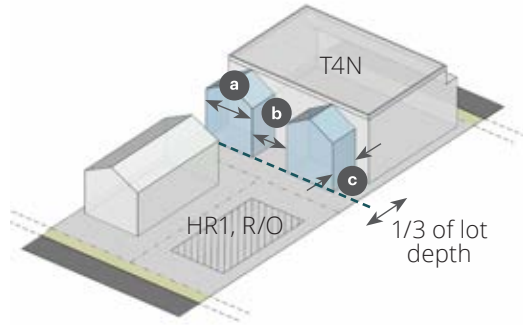

**Adjacent to MR2.5 and R5**

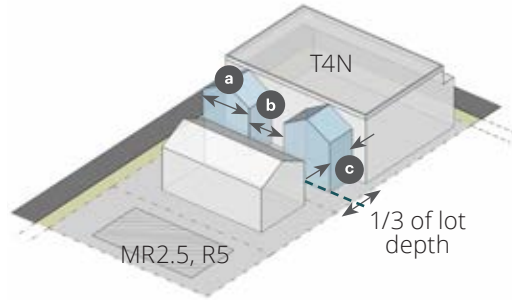

**Key**

- Main Body
- House-Form Massing
- Rear setback per Sub-Section C (Building Placement)
- a Wing Width
- b Wing Separation
- c Wing Depth

**G. Adjacency Standards**

**Historic Resource Adjacency**

Where adjacent to a designated historic resource refer to DTFBC Section 3.2.070 (Historic Resource Adjacency Standards) in addition to the standards of this zone.

**House-Form Massing**

Where abutting the MR2.5, R5, HR1 or R/O zones, house-form massing is required within rear 1/3 of the lot.

Building Width	Required Wing(s)	Wing Size (max.) <sup>1</sup> a x c	Height
< 75'	None	-	-
> 75' - 100'	1 min.	25' x 35'	35'
>100' - 150'	2 min.;	25' x 35'	35'
	or 1 at	35' x 35'	
	and 1 at	35' x 65'	
>150'	3 min.;	25' x 35'	35'
	1 at	25' x 35'	
	and 2 at	35' x 65'	
Wing Separation: 10' min.			b

<sup>1</sup> Min. wing size is 15' by 15'.



### H. Parking

#### Required Spaces (min.) for New Buildings<sup>1</sup>

Use Type	Vehicular Spaces	Bicycle Spaces
Residential Uses <sup>2,3</sup>		
Studio or 1 Bedroom	0.75	1.0
2 Bedrooms	1.0	2.0
3 or more Bedrooms	1.5	3.0
Non-Residential Uses (amount per tenant in building)		
≤ 2,500 sf	None	
> 2,500 sf	3 per 1,000 sf	

<sup>1</sup> For buildings located within the Downtown parking District, the off-street parking requirement is waived for up to 1.0 FAR of the total square footage. For buildings with square footage above 1.0 FAR and for all residential uses off-street parking shall be provided. Refer to SRMC Section 14.18.060 (Downtown Parking District).

<sup>2</sup> In West End Village see SRMC Section 14.18.040 (Parking Requirements).

<sup>3</sup> Guest parking not required except in West End Village where 1 parking space per 5 spaces is required.

#### Setback (Distance from ROW/ Lot Line)<sup>1</sup>

Front	25' min.	<b>S</b>
Side Street	25' min. when enclosed within building, 5' min unenclosed <sup>2</sup>	<b>T</b>
Side	5' min.	<b>U</b>
Rear	5' min.	<b>Y</b>

<sup>1</sup> 0' minimum setback for subterranean parking in compliance with frontage requirements.

<sup>2</sup> In compliance with facade zone requirements in Sub-Section C (Building Placement) of this Section.

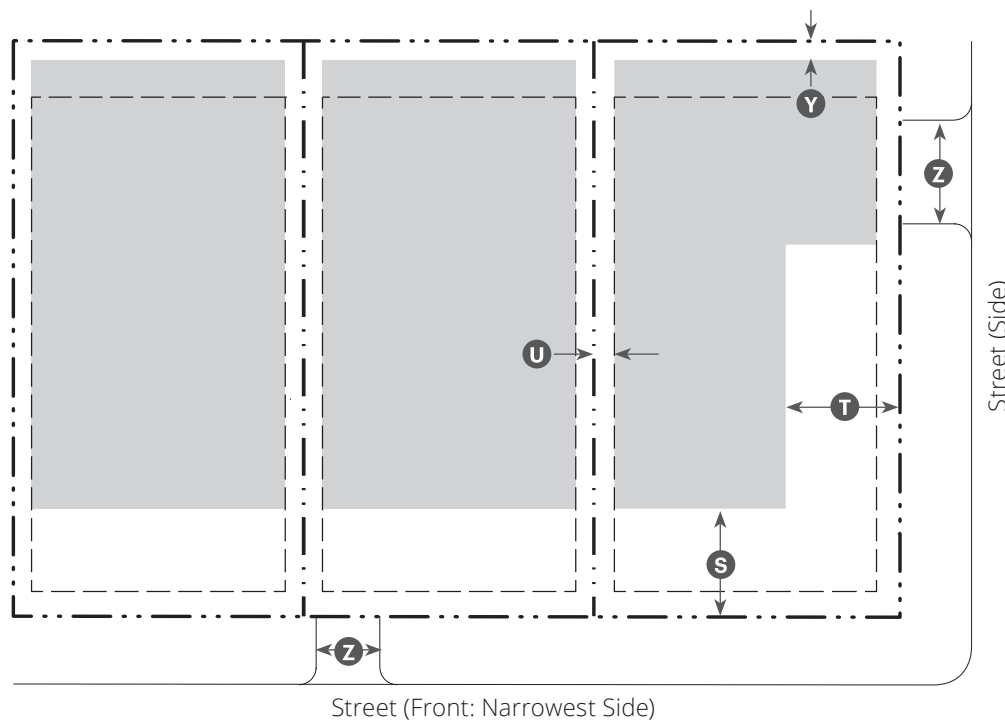

### H. Parking (Continued)

#### Driveway

Driveway Width, within parking setbacks	<b>Z</b>
Front	12' max.
Side Street/ Alley	20' max.
Curb Cut	14' max.
Planter (on each side)	2'
Distance between Driveways	40' min.

Curb Cut Width along alley may exceed 12'.

Driveways may be shared between adjacent lots and may exceed max. allowed width by 3'.

Driveways are not allowed in front on a corner lot.

Refer SRMC Section 14.18.040 (Parking Requirements) for dimensions of parking spaces.

#### Key

- - - ROW/ Lot Line
- - - Building Setback Line
- Parking Area (at or above grade)

### 2.3.040 T4 Main Street (T4MS 40/50, T4MS 40/60, T4MS 50/70, and T4MS 60/80)



#### A. Intent

A walkable, vibrant district of medium-to-large footprint, moderate intensity, mixed-use buildings and housing choices, supporting neighborhood and community-serving ground floor shopping, food and services, including civic, institutional, maker/ craft/ artisanal businesses (both indoor and outdoor).

#### B. Sub-Zone(s)

T4MS 40/50 Open, T4MS 40/60 Open and T4MS 50/70 Open. The open sub-zone allows more uses, additional signage and sometimes additional frontages, within the same form and character of the base zone.

The following are generally appropriate form elements in the zone.

- Primarily Block-Form Buildings **A**
- Building Height 40' to 80', as per Regulating Plan **B**
- Attached Buildings **C**
- Small-to-No Front Setbacks **D**
- No Side Setbacks **E**
- Porch Projecting, Porch Engaged, Dooryard, Stoop, Forecourt, Maker Shopfront, Shopfront, Terrace, Gallery Frontage Types **F**

C. Building Placement		
<b>Setback (Distance from ROW/ Lot Line)</b>		
Front (Facade Zone)	0' min.; 10' max.	<b>G</b>
Side Street (Facade Zone)	0' min.; 10' max.	<b>H</b>
Total length of facade required within or abutting the Facade Zone, exclusive of setbacks <sup>1</sup>		
Front	80% min.	
Side Street	70% min.	
Side	0' min.	<b>I</b>
Rear <sup>2</sup>	0' min.	<b>J</b>
<b>Civic Space</b>		
<b>Site Size (sf) or Lot Width</b>	<b>Required Area (min.)</b>	
15,000 to 30,000 or 100' - 150'	200 sf	
> 30,000 or 150' - 250'	1,000 sf	
Lot Width >250'	5% of Site	

<sup>1</sup> Facades facing a street or civic space shall be designed in compliance with DTFBC Division 3.2 (Massing and Facade Articulation Standards).

<sup>2</sup> See Sub-Section G (Adjacency Standards) of this Section for additional refinements.

D. Encroachments <sup>1</sup>				
Encroachment Type	Front	Side St.	Side	Rear
Frontage Types <sup>2</sup>	A	A	X	A
Steps to Building Entry <sup>3</sup>	3' max.	3' max.	-	3' max.
Canopies/ Overdoors, Signage <sup>4</sup>	4' max.	4' max.	2' max.	3' max.
Balconies, Unenclosed Porches, Bay Windows <sup>4</sup>	4' max.	4' max.	-	5' max.
Corner Elements	3' min. to 4' max.	n/a	n/a	n/a

**Key**                      A = Allowed                      X = Not Allowed

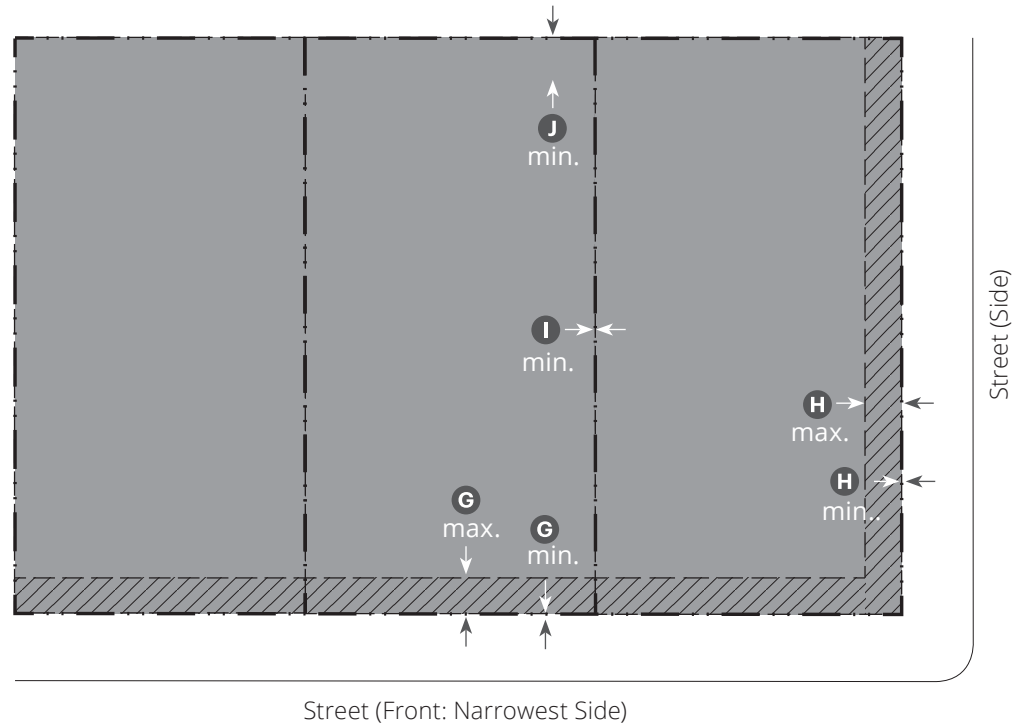

**D. Encroachments<sup>1</sup> (Continued)**

<sup>1</sup> Includes encroachments into building setbacks and facade zone.

<sup>2</sup> See Sub-Section F (Frontages) of this Section for allowed types and standards.

<sup>3</sup> Requires building setback.

<sup>4</sup> May also encroach into required setbacks.

**Key**

- ROW/ Lot Line
- Buildable Area
- Building Setback Line
- ▨ Facade Zone

E. Building Form and Maximum Envelope		
Height	Base	Height Bonus <sup>1</sup>
<b>Overall Building Height<sup>2,3,4</sup></b>		
T4MS 40/50 and T4MS 40/50 Open	40' max. 50' max.	<b>K</b>
T4MS 40/60 and T4MS 40/60 Open	40' max. 60' max.	<b>K</b>
T4MS 50/70 and T4MS 50/70 Open	50' max. 70' max.	<b>K</b>
T4MS 60/80	60' max. 80' max.	<b>K</b>
<b>Highest Top Plate/ Highest Eave Measurement</b>		
T4MS 40/50 Open	35' max. 45' max.	<b>L</b>
T4MS 40/60 Open	35' max. 55' max.	<b>L</b>
T4MS 50/70 and T4MS 50/70 Open	45' max. 65' max.	<b>L</b>
T4MS 60/80	55' max. 75' max.	<b>L</b>
<b>Stepback<sup>5</sup></b>		
<b>T4MS 40/50 and T4MS 40/50 Open</b>		
Front	10' min. at 35'	<b>M</b>
Side Street	10' min. at 35'	<b>N</b>
Rear	10' min. at 35'	<b>O</b>
<b>T4MS 40/60 and T4MS 40/60 Open</b>		
Front	10' min. at 35'	<b>M</b>
Side Street	10' min. at 35'	<b>N</b>
Rear	10' min. at 35'	<b>O</b>
<b>T4MS 50/70 and T4MS 50/70 Open</b>		
Front	10' min. at 45'	<b>M</b>
Side Street	10' min. at 45'	<b>N</b>
Rear	10' min. at 45'	<b>O</b>
<b>T4MS 60/80<sup>6</sup></b>		
Front	10' min. at 55'	<b>M</b>
Side Street	10' min. at 55'	<b>N</b>
Rear	10' min. at 55'	<b>O</b>

E. Building Form and Maximum Envelope (Continued)		
Ground Floor Standards		
Ground Floor Finish Level		<b>P</b>
Residential <sup>7</sup>	12" min.	
Non-Residential <sup>8</sup>	Flush with Sidewalk	
Ground Floor Ceiling	14' min.	<b>Q</b>
Depth, Ground-Floor Space	30' min. front; 12' min. other	<b>R</b>

<sup>1</sup> See SRMC Section 14.16.190 (Height Bonus) for requirements to qualify for height bonus.

<sup>2</sup> See DTFBC Figure 2.2.040.A (Regulating Plan) for further refinements.

<sup>3</sup> Corner elements may exceed the maximum allowed height by up to 10' for a horizontal area up to 20' x 20'.

<sup>4</sup> See SRMC Section 14.16.120 (Exclusions to the Maximum Height Requirement) for exclusions to the overall building height.

<sup>5</sup> Stepback not required when the uppermost floor and up to two floors including the uppermost floor are within a mansard roof. See DTFBC Section 3.2.060 (Windows and Openings).

<sup>6</sup> Buildings in T4MS 60/80 zone when located on the south side of the street and subject to a height bonus shall require a solar study to determine that the opposing sidewalk and/or public space shall not be more than 50% shaded at 12 noon on the Spring equinox (March 21st). Exemptions to this requirement may apply to affordable housing projects.

<sup>7</sup> Common entries may be set at grade in compliance with local and federal accessibility standards.

<sup>8</sup> Or as required to comply with FEMA base flood elevation.

**Building Form**

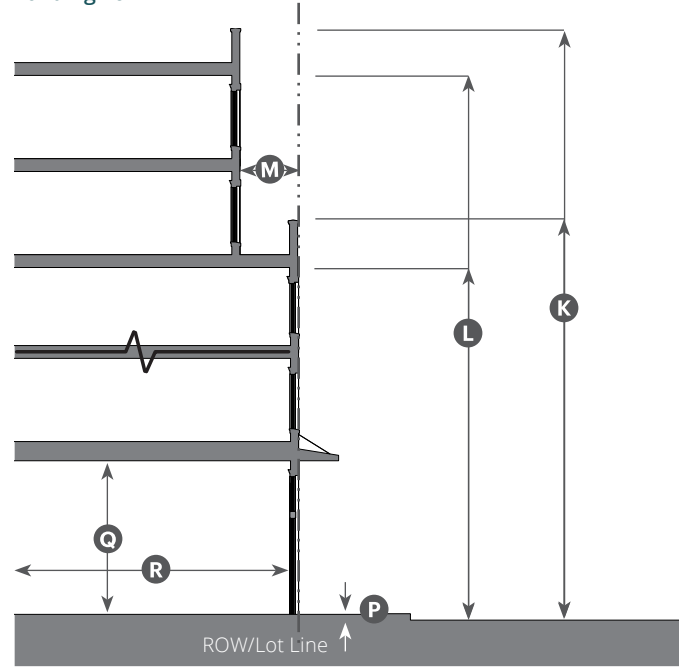

**F. Frontages<sup>1</sup>**

Frontage Type	Front	Side St.	Standards
Porch Projecting	A <sup>2</sup>	A <sup>2</sup>	3.3.030
Porch Engaged	A <sup>2</sup>	A <sup>2</sup>	3.3.040
Dooryard	A	A	3.3.050
Stoop	A <sup>2</sup>	A <sup>2</sup>	3.3.060
Forecourt	A	A	3.3.070
Maker Shopfront	A <sup>2</sup>	A <sup>2</sup>	3.3.080
Shopfront	A	A	3.3.090
Terrace	A	A	3.3.100
Gallery	A	A	3.3.110

<sup>1</sup> Minimum of one Frontage Type per street-facing facade.

<sup>2</sup> Only in Open Sub-Zone.

**Key** A = Allowed

**Maximum Envelope in Mid-Block and Corner Condition**

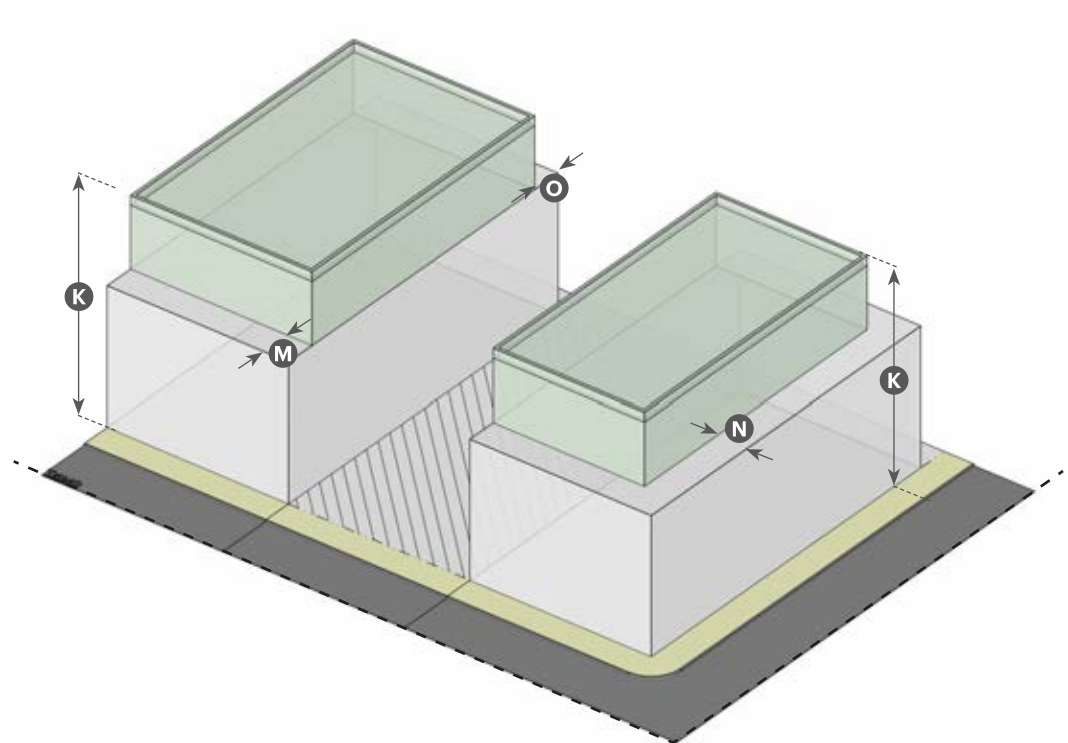

**Key**

- Max. Envelope without Height Bonus (Base)
- Max. Envelope with Height Bonus
- - - Street Centerline

Adjacent to T4N 30/40 and T4N 40/50

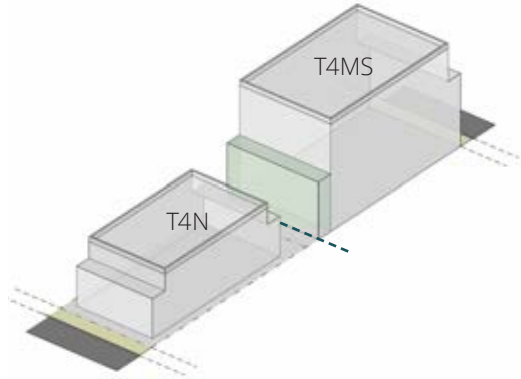

Adjacent to DR

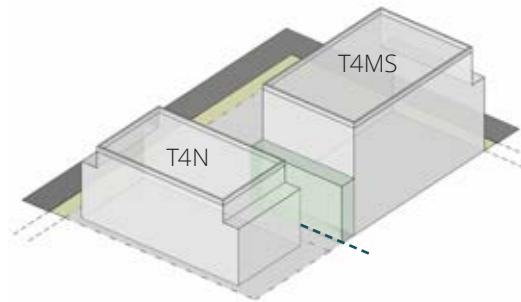
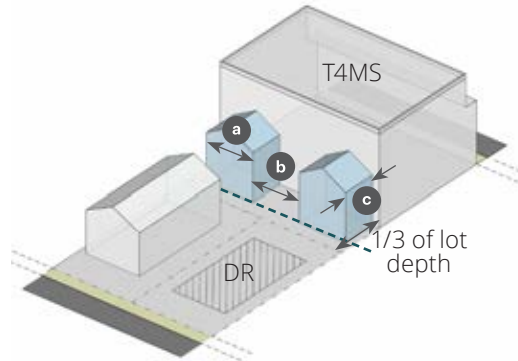

Key

- Main Body
- Rear Stepback
- House-Form Massing
- Rear setback per Sub-Section C (Building Placement)
- a Wing Width
- b Wing Separation
- c Wing Depth

G. Adjacency Standards

Historic Resource Adjacency

Where adjacent to a designated historic resource refer to DTFBC Section 3.2.070 (Historic Resource Adjacency Standards) in addition to the standards of this zone.

Building Placement and Height

	Setback	Stepback
Open		
Rear	10' min.	10' min at 35'

Where abutting the T4N 30/40, T4N 40/50 or T4N 40/50

House-Form Massing

Where abutting the DR zone, house-form massing is required within rear 1/3 of the lot.

Building Width	Required Wing(s)	Wing Size (max.) <sup>1</sup> a x c	Height
< 75'	None	-	-
> 75' - 100'	1 min.	25' x 35'	35'
>100' - 150'	2 min.;	25' x 35'	35'
	or 1 at	35' x 35'	
	and 1 at	35' x 65'	
>150'	3 min.;	25' x 35'	35'
	1 at	25' x 35'	
	and 2 at	35' x 65'	

Wing Separation: 10' min. b

<sup>1</sup>Min. wing size is 15' by 15'.

H. Parking		
Required Spaces (min.) for New Buildings <sup>1</sup>		
Use Type	Vehicular Spaces	Bicycle Spaces
Residential Uses <sup>2,3</sup>		
Studio or 1 Bedroom	0.5	1.0
2 Bedrooms	1.0	2.0
3 or more Bedrooms	1.5	3.0
Non-Residential Uses (amount per tenant in building)		
≤ 6,000 sf	None	
> 6,000 sf	2.75 per 1,000 sf	

<sup>1</sup> For buildings located within the Downtown parking District, the off-street parking requirement is waived for up to 1.0 FAR of the total square footage. For buildings square footage above 1.0 FAR and for all residential uses off-street parking shall be provided. Refer to SRMC Section 14.18.060 (Downtown Parking District).

<sup>2</sup> In West End Village see DTFBC Section 14.18.040 (Parking Requirements).

<sup>3</sup> Guest parking not required except in West End Village where 1 parking space per 5 spaces is required.

Setback (Distance from ROW/ Lot Line) <sup>1</sup>		
Front	35' min.	<b>S</b>
Side Street	25' min when enclosed within building, 5' min unenclosed <sup>2</sup>	<b>T</b>
Side	0' min.	<b>U</b>
Rear	5' min.	<b>Y</b>

<sup>1</sup> 0' minimum setback for subterranean parking in compliance with frontage requirements.

<sup>2</sup> In compliance with facade zone requirements in Sub-Section C (Building Placement) of this Section.

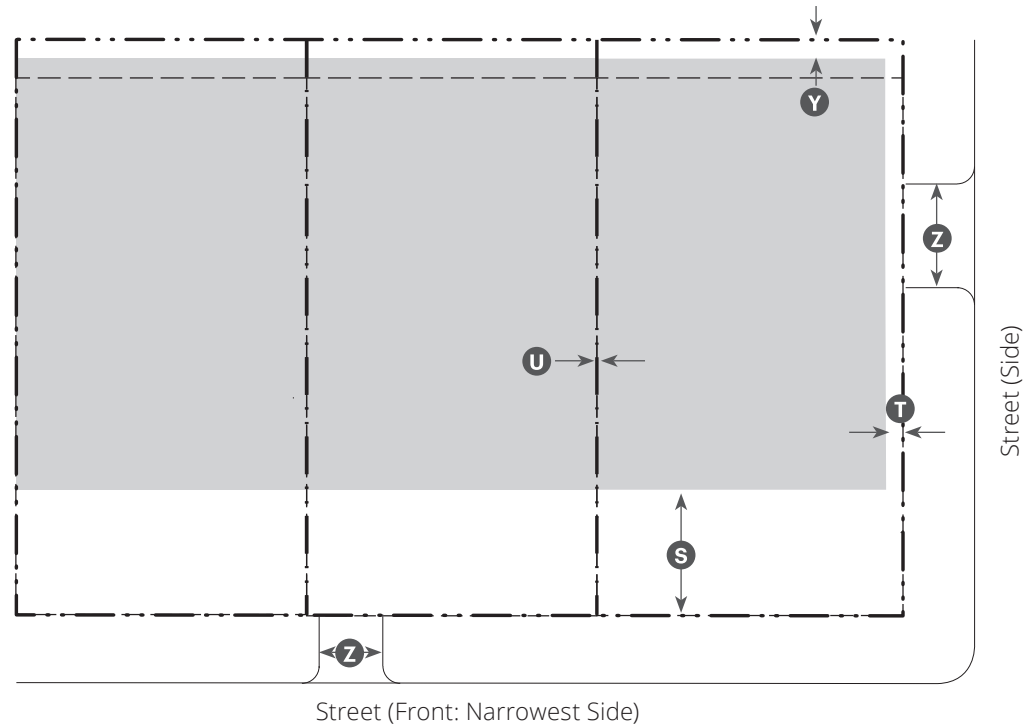

**H. Parking (Continued)**

**Driveway**

Driveway Width, within parking setbacks	<b>Z</b>
Front	12' max.
Side Street/ Alley	20' max.
Curb Cut	14' max.
Planter (on each side)	2'
Distance between Driveways	40' min.

Curb Cut Width along alley may exceed 12'.

Driveways may be shared between adjacent lots and may exceed max. allowed width by 3'.

Driveways are not allowed in front on a corner lot.

Refer SRMC Section 14.18.040 (Parking Requirements) for dimensions of parking spaces.

**Key**

- - - ROW/ Lot Line
- - - Building Setback Line
- Parking Area (at or above grade)

### 2.3.050 T5 Neighborhood (T5N 40/60 and T5N 50/70)



#### A. Intent

A walkable neighborhood environment of large footprint, high-intensity mixed-use buildings, supporting and within short walking distance of neighborhood shopping, services, and transit.

#### B. Sub-Zone(s)

T5N 40/60 Open and T5N 50/70 Open. The open sub-zone allows more uses, additional signage and sometimes additional frontages, within the same form and character of the base zone.

The following are generally appropriate form elements in the zone.

- Primarily Block-Form Buildings A
- Building Height 40' to 70', as per Regulating Plan B
- Primarily Attached Buildings C
- Small-to-No Front Setbacks D
- No Side Setbacks E
- Porch Projecting, Porch Engaged, Dooryard, Stoop, Forecourt, Shopfront, Terrace Frontage Types F



**C. Building Placement**

**Setback (Distance from ROW/ Lot Line)**

Front (Facade Zone) <sup>3</sup>	0' min.; 15' max.	<b>G</b>
Side Street (Facade Zone) <sup>3</sup>	0' min.; 15' max.	<b>H</b>

Total length of facade required within or abutting the Facade Zone, exclusive of setbacks<sup>1</sup>

Front	70% min.
Side Street	60% min.

Side <sup>2</sup>	0' min.	<b>I</b>
Rear <sup>2</sup>	0' min.	<b>J</b>

**Civic Space**

**Site Size (sf) or Lot Width      Required Area (min.)**

15,000 to 30,000 or 100' - 150'	200 sf
> 30,000 or 150' - 250'	1,000 sf
Lot Width >250'	5% of Site

<sup>1</sup> Facades facing a street or civic space shall be designed in compliance with DTFBC Division 3.2 (Massing and Facade Articulation Standards).

<sup>2</sup> See Sub-Section G (Adjacency Standards) of this Section for additional refinements.

**D. Encroachments<sup>1</sup>**

Encroachment Type	Front	Side St.	Side	Rear
Frontage Types <sup>2</sup>	A	A	X	A
Steps to Building Entry <sup>3</sup>	3' max.	3' max.	-	5' max.
Canopies/ Overdoors, Signage <sup>4</sup>	4' max.	4' max.	2' max.	3' max.
Balconies, Bay Windows <sup>4</sup>	4' max.	4' max.	-	5' max.
Corner Elements	3' min. to 4' max.	n/a	n/a	n/a

<sup>1</sup> Includes encroachments into building setbacks and facade zone.

<sup>2</sup> See Sub-Section F (Frontages) of this Section for allowed types and standards.

<sup>3</sup> Requires building setback.

<sup>4</sup> May also encroach into required setbacks.

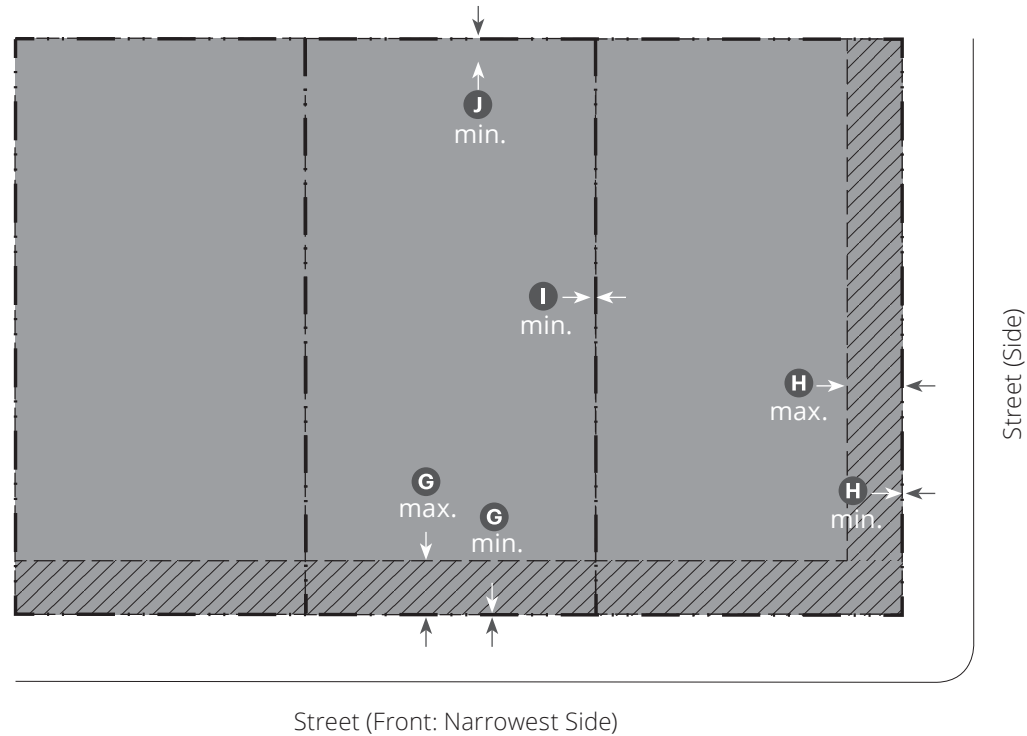

**Key**

- ROW/ Lot Line
- Buildable Area
- Building Setback Line
- ▨ Facade Zone

**Key**

- A = Allowed
- X = Not Allowed

E. Building Form and Maximum Envelope		
Height	Base	Height Bonus <sup>1</sup>
<b>Overall Building Height<sup>2,3,4</sup></b>		
T5N 40/60 and T5N 40/60 Open	40' max. 60' max.	<b>K</b>
T5N 50/70 and T5N 50/70 Open	50' max. 70' max.	<b>K</b>
<b>Highest Top Plate/ Highest Eave Measurement</b>		
T5N 40/60 and T5N 40/60 Open	35' max. 55' max.	<b>L</b>
T5N 50/70 and T5N 50/70 Open	45' max 65' max.	<b>L</b>
<b>Stepback<sup>5</sup></b>		
<b>T5N 40/60 and T5N 40/60 Open</b>		
Front	10' min. at 35'	<b>M</b>
Side Street	10' min. at 35'	<b>N</b>
Rear	10' min. at 35'	<b>O</b>
<b>T5N 50/70 and T5N 50/70 Open</b>		
Front	10' min. at 45'	<b>M</b>
Side Street	10' min. at 45'	<b>N</b>
Rear	10' min. at 45'	<b>O</b>
<b>Ground Floor Standards</b>		
Ground Floor Finish Level		<b>P</b>
Residential <sup>6</sup>	12" min.	
Non-Residential <sup>7</sup>	Flush with Sidewalk	
Ground Floor Ceiling	10' min.	<b>Q</b>
Depth, Ground-Floor Space	30' min. front; 12' min. other	<b>R</b>

<sup>1</sup> See SRMC Section 14.16.190 (Height Bonus) for requirements to qualify for height bonus.

<sup>2</sup> See DTFBC Figure 2.2.040.A (Regulating Plan) for further refinements.

<sup>3</sup> Corner elements may exceed the maximum allowed height by up to 10' for a horizontal area up to 20' x 20'.

### E. Building Form and Maximum Envelope (Continued)

<sup>4</sup> See SRMC Section 14.16.120 (Exclusions to the Maximum Height Requirement) for exclusions to overall building height.

<sup>5</sup> Stepback not required when the uppermost floor and up to two floors including the uppermost floor are within a mansard roof. See DTFBC Section 3.2.060 (Windows and Openings).

<sup>6</sup> Common entries may be set at grade in compliance with local and federal accessibility standards.

<sup>7</sup> Or as required to comply with FEMA base flood elevation.

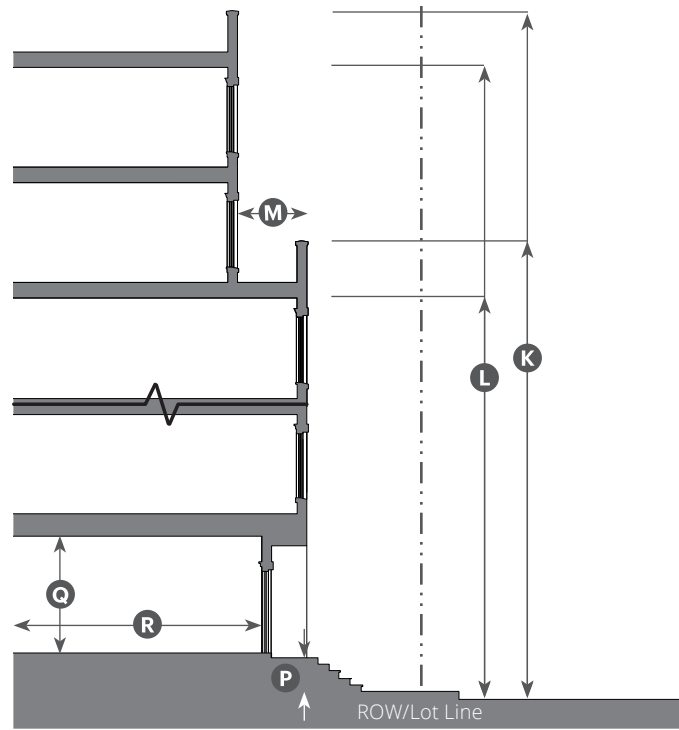

Maximum Envelope in Mid-Block and Corner Condition

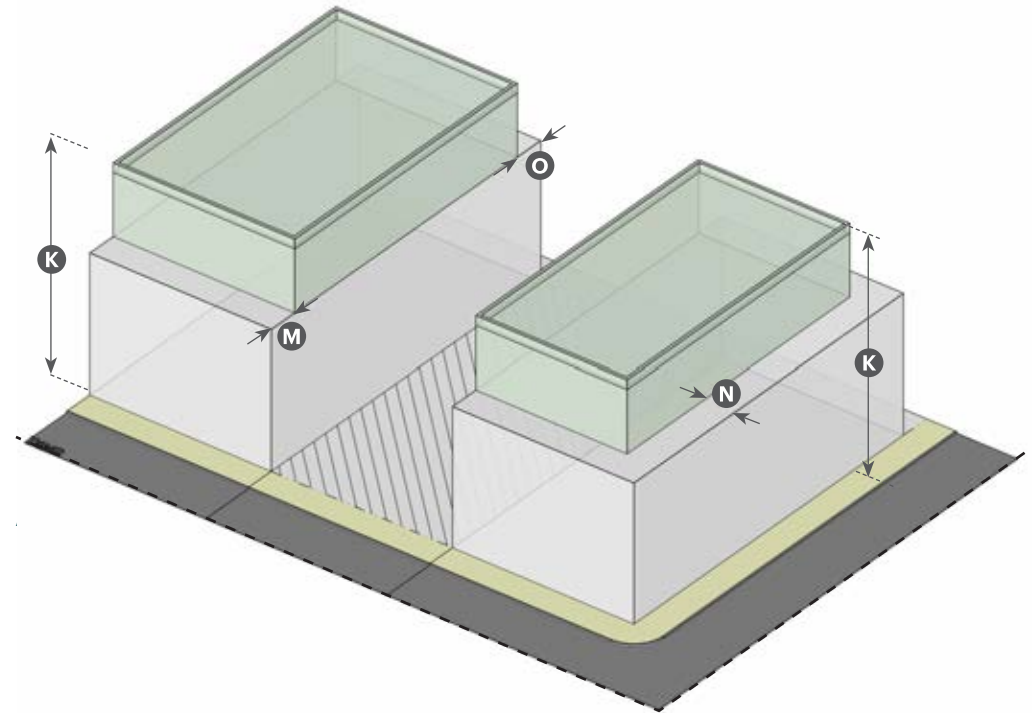

**F. Frontages<sup>1</sup>**

Frontage Type	Front	Side St.	Standards
Porch Projecting	A	A	3.3.030
Porch Engaged	A	A	3.3.040
Dooryard	A	A	3.3.050
Stoop	A	A	3.3.060
Forecourt	A	A	3.3.070
Shopfront	A <sup>2</sup>	A <sup>2</sup>	3.3.090
Terrace	A	A	3.3.100

<sup>1</sup> Minimum of one Frontage Type per street-facing facade.

<sup>2</sup> Only in Open Sub-Zone.

**Key** A = Allowed

**Key**

- Max. Envelope without Height Bonus (Base)
- Max. Envelope with Height Bonus
- Street Centerline

Adjacent to T4N 30/40 and T4N 40/50

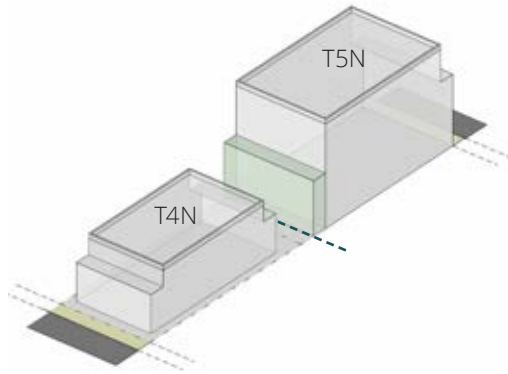

Adjacent to MR2.5 and R5

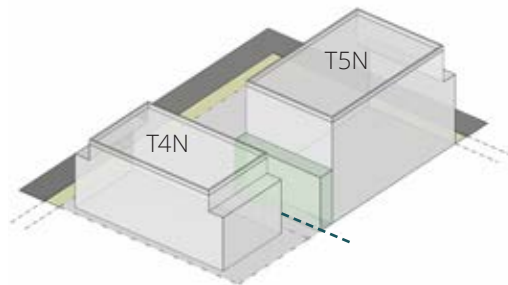
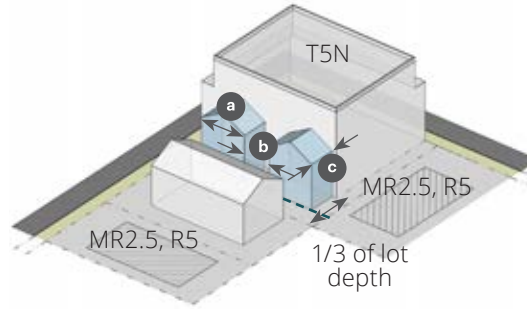

**Key**

- Main Body
- Rear Stepback
- House-Form Massing
- Rear setback per Sub-Section C (Building Placement)
- a Wing Width
- b Wing Separation
- c Wing Depth

**G. Adjacency Standards**

**Historic Resource Adjacency**

Where adjacent to a designated historic resource refer to DTFBC Section 3.2.070 (Historic Resource Adjacency Standards) in addition to the standards of this zone.

**Building Placement and Height**

	Setback	Stepback
Open		
Rear	10' min.	10' min at 35'

Where abutting the MR2.5 or R5

Side	10' min.
------	----------

**House-Form Massing**

Where abutting the MR2.5 or R5 zones, house-form massing is required within rear 1/3 of the lot.

Building Width	Required Wing(s)	Wing Size (max.) <sup>1</sup> a x c	Height
< 75'	None	-	-
> 75' - 100'	1 min.	25' x 35'	35'
>100' - 150'	2 min.;	25' x 35'	35'
	or 1 at	35' x 35'	
	and 1 at	35' x 65'	
>150'	3 min.;		35'
	1 at	25' x 35'	
	and 2 at	35' x 65'	

Wing Separation: 10' min. b

<sup>1</sup>Min. wing size is 15' by 15'.

H. Parking		
Required Spaces (min.) for New Buildings <sup>1</sup>		
Use Type	Vehicular Spaces	Bicycle Spaces
Residential Use <sup>2,3</sup>		
Studio or 1 Bedroom	0.75	1.0
2 Bedrooms	1.0	2.0
3 or more Bedrooms	1.5	3.0
Non-Residential Uses (amount per tenant in building)		
≤ 2,500 sf	None	
> 2,500 sf	2.75 per 1,000 sf	

<sup>1</sup> For buildings located within the Downtown parking District, the off-street parking requirement is waived for up to 1.0 FAR of the total square footage. For buildings square footage above 1.0 FAR and for all residential uses off-street parking shall be provided. Refer to SRMC Section 14.18.060 (Downtown Parking District).

<sup>2</sup> In West End Village see SRMC Section 14.18.040 (Parking Requirements).

<sup>3</sup> Guest parking not required except in West End Village where 1 parking space per 5 spaces is required.

Setback (Distance from ROW/ Lot Line) <sup>1</sup>		
Front	30' min.	<b>S</b>
Side Street	25' min when enclosed within building, 5' min unenclosed <sup>2</sup>	<b>T</b>
Side	5' min.	<b>U</b>
Rear	5' min.	<b>Y</b>

<sup>1</sup> 0' minimum setback for subterranean parking in compliance with frontage requirements.

<sup>2</sup> In compliance with facade zone requirements in Sub-Section C (Building Placement) of this Section.

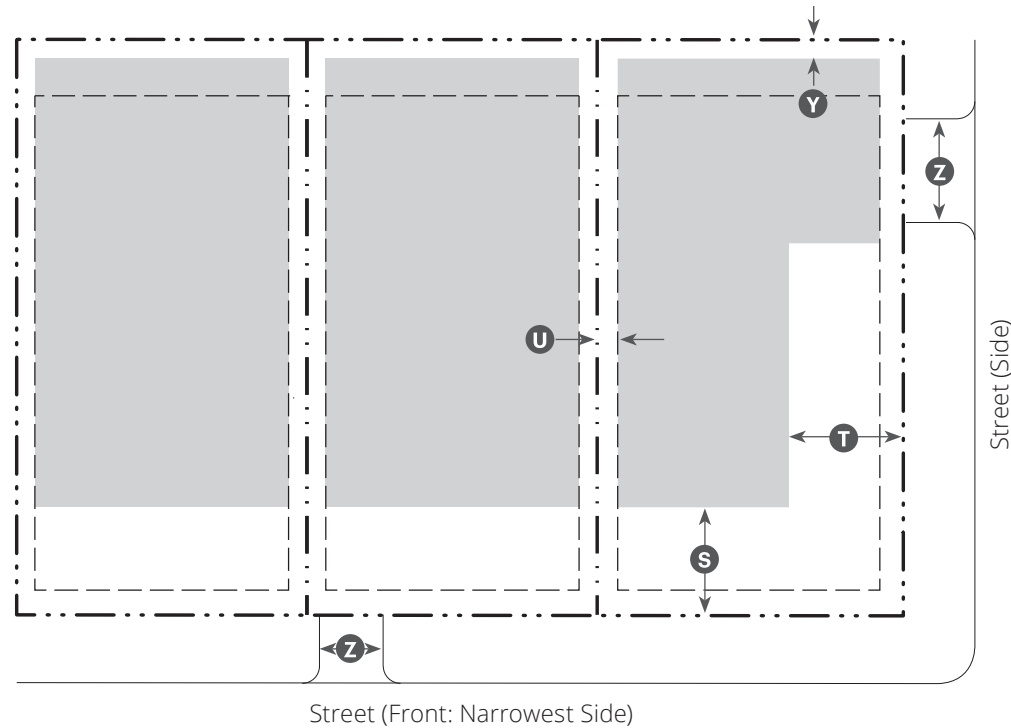

**H. Parking (Continued)**

**Driveway**

Driveway Width, within parking setbacks	<b>Z</b>
Front	12' max.
Side Street/ Alley	20' max.
Curb Cut	14' max.
Planter (on each side)	2'
Distance between Driveways	40' min.

Curb Cut Width along alley may exceed 12'.

Driveways may be shared between adjacent lots and may exceed max. allowed width by 3'.

Driveways are not allowed in front on a corner lot.

Refer SRMC Section 14.18.040 (Parking Requirements) for dimensions of parking spaces.

**Key**

- - - ROW/Lot Line
- - - Building Setback Line
- Parking Area (at or above grade)

### 2.3.060 T5 Main Street (T5MS 70/90)

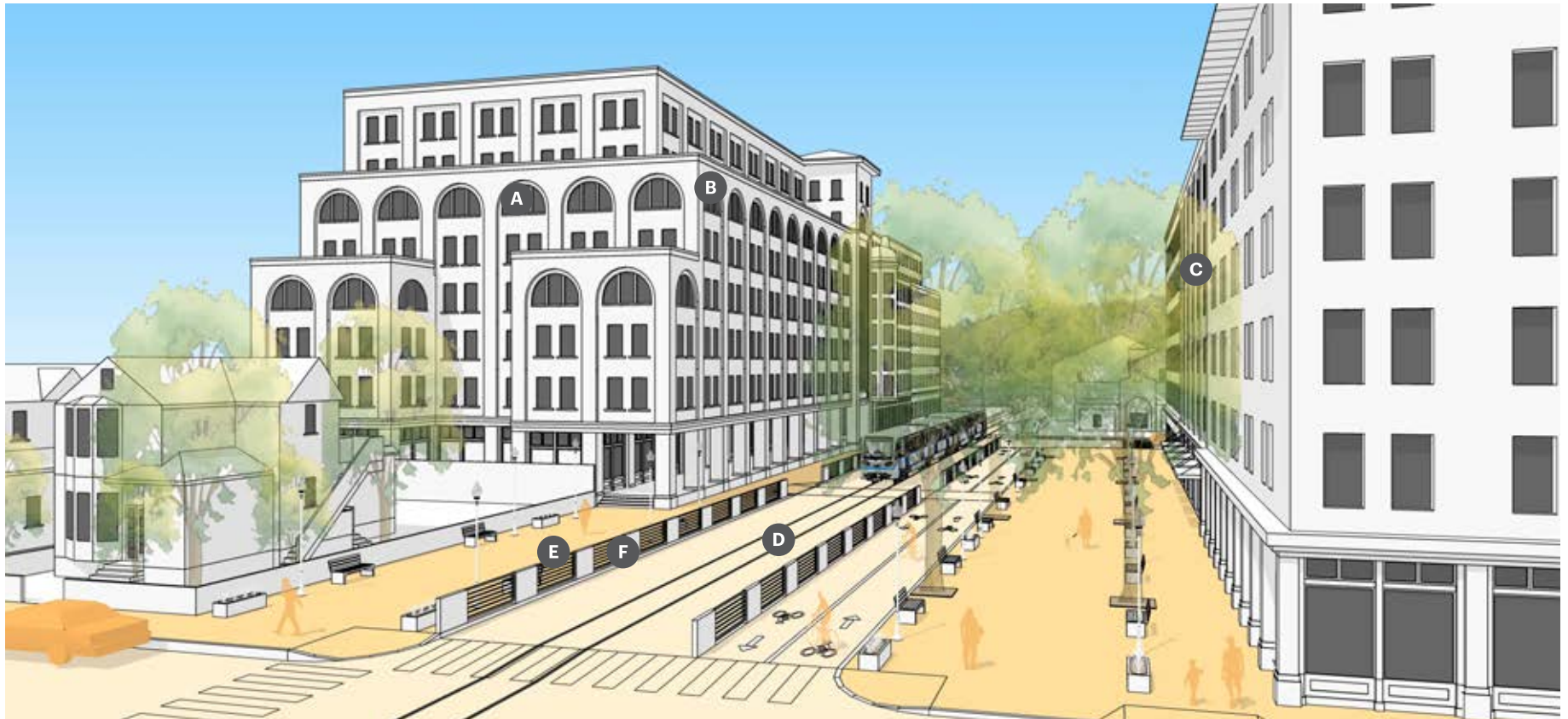

#### A. Intent

A walkable, urban neighborhood environment with large footprint, high-intensity mixed-use buildings in close proximity to the multimodal transit station, with neighborhood-serving shopping and services.

#### B. Sub-Zone(s)

None

The following are generally appropriate form elements in the zone.

- Primarily Block-Form Buildings A
- Building Height 70' to 90' B
- Attached Buildings C
- Small-to-No Front Setbacks D
- No Side Setbacks E
- Forecourt, Shopfront, Terrace, Gallery Frontage Types F

**C. Building Placement**

**Setback (Distance from ROW/ Lot Line)**

Front (Facade Zone)	0' min.; 5' max.	<b>G</b>
Side Street (Facade Zone)	0' min.; 5' max.	<b>H</b>

Total length of facade required within or abutting the Facade Zone, exclusive of setbacks<sup>1</sup>

Front	90% min.
Side Street	80% min.

Side	0' min.	<b>I</b>
Rear <sup>2</sup>	0' min.	<b>J</b>

**Civic Space**

**Site Size (sf) or Lot Width      Required Area (min.)**

15,000 to 30,000 or 100' - 150'	200 sf
> 30,000 or 150' - 250'	1,000 sf
Lot Width >250'	5% of Site

<sup>1</sup> Facades facing a street or civic space shall be designed in compliance with DTFBC Division 3.2 (Massing and Facade Articulation Standards).

<sup>2</sup> See Sub-Section G (Adjacency Standards) of this Section for additional refinements.

**D. Encroachments<sup>1</sup>**

**Encroachment Type      Front      Side St.      Side      Rear**

Frontage Types <sup>2</sup>	A	A	X	A
Steps to Building Entry <sup>3</sup>	3' max.	3' max.	-	5' max.
Canopies/ Overdoors, Signage <sup>4</sup>	4' max.	4' max.	2' max.	3' max.
Balconies, Bay Windows <sup>4</sup>	4' max.	4' max.	-	5' max.
Corner Elements	3' min. to 4' max.	n/a	n/a	n/a

<sup>1</sup> Includes encroachments into building setbacks and facade zone.

<sup>2</sup> See Sub-Section F (Frontages) of this Section for allowed types and standards.

<sup>3</sup> Requires building setback.

<sup>4</sup> May also encroach into required setbacks.

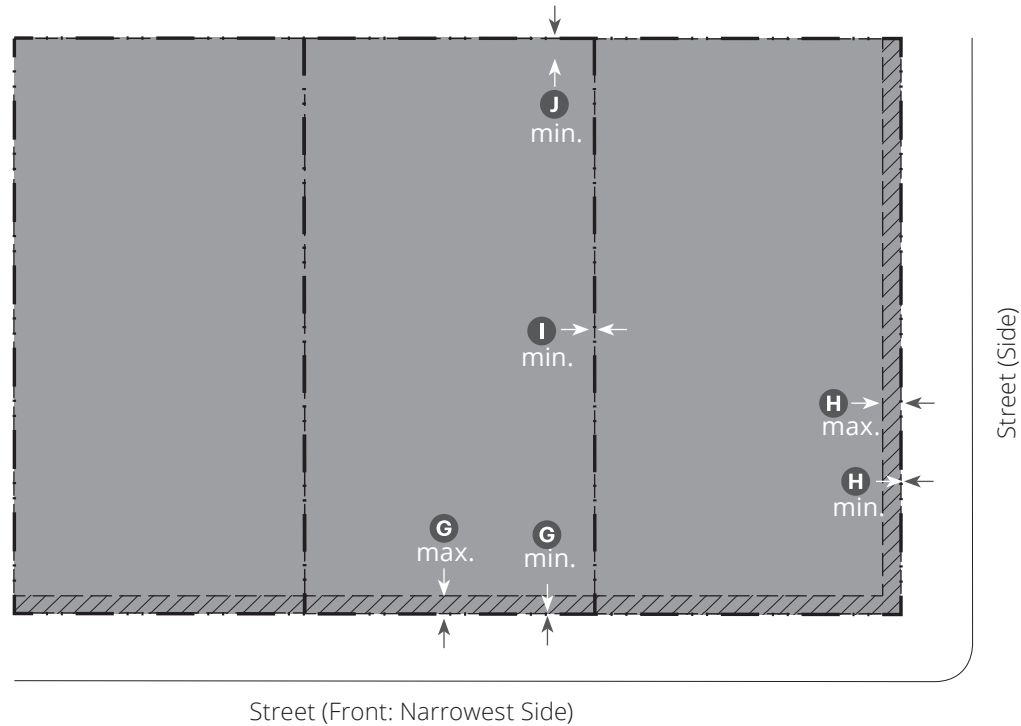

**Key**

- ROW/ Lot Line
- Buildable Area
- Building Setback Line
- ▨ Facade Zone

**Key**

- A = Allowed
- X = Not Allowed

E. Building Form and Maximum Envelope		
Height	Base	Height Bonus <sup>1</sup>
<b>Overall Building Height<sup>2,3,4</sup></b>		
T5MS 70/90	70' max. 90' max.	<b>K</b>
<b>Highest Top Plate/ Highest Eave Measurement</b>		
T5MS 70/90	65' max. 85' max.	<b>L</b>
<b>Stepback<sup>5,6</sup></b>		
<b>T5MS 70/90</b>		
Front	10' min. at 65'	<b>M</b>
Side Street	10' min. at 65'	<b>N</b>
Rear	10' min. at 65'	<b>O</b>
<b>Ground Floor Standards</b>		
Ground Floor Finish Level		<b>P</b>
Residential <sup>7</sup>	12" min.	
Non-Residential <sup>8</sup>	Flush with Sidewalk	
Ground Floor Ceiling	14' min.	<b>Q</b>
Depth, Ground-Floor Space	30' min. front; 12' min. other	<b>R</b>

<sup>1</sup> See SRMC Section 14.16.190 (Height Bonus) for requirements to qualify for height bonus.

<sup>2</sup> See DTFBC Figure 2.2.040.A (Regulating Plan) for further refinements.

<sup>3</sup> Corner elements may exceed the maximum allowed height by up to 10' for a horizontal area up to 20' x 20'.

<sup>4</sup> See SRMC Section 14.16.120 (Exclusions to the Maximum Height Requirement) for exclusions to overall building height.

<sup>5</sup> Stepback not required when the uppermost floor and up to two floors including the uppermost floor are within a mansard roof. See DTFBC Section 3.2.060 (Windows and Openings).

**E. Building Form and Maximum Envelope (Continued)**

<sup>6</sup> Buildings in T5MS 70/90 zone when subject to a height bonus shall require a solar study to determine that the opposing sidewalk and/or public space shall not be more than 50% shaded at 12 noon on the Spring equinox (March 21st). Exemptions to this requirement may apply to affordable housing projects.

<sup>7</sup> Common entries may be set at grade in compliance with local and federal accessibility standards.

<sup>8</sup> Or as required to comply with FEMA base flood elevation.



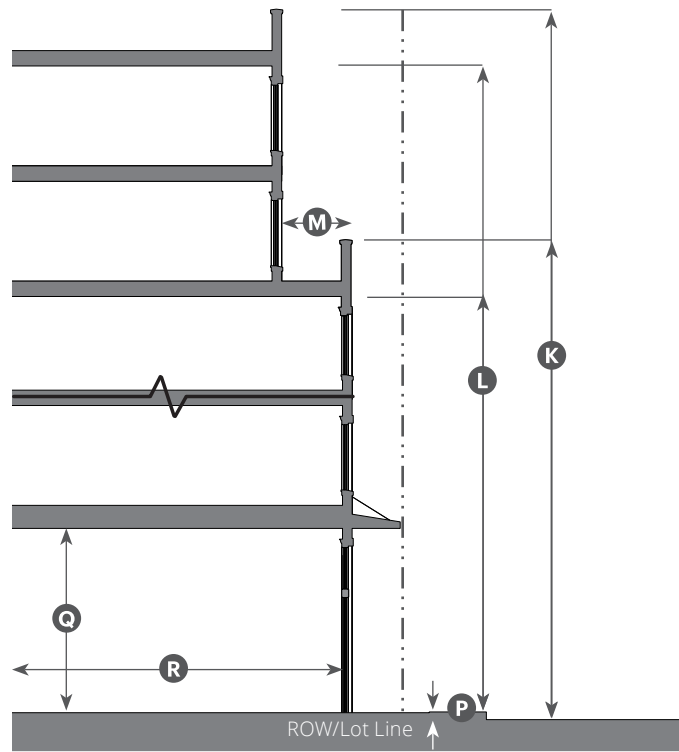

Maximum Envelope in Mid-Block and Corner Condition

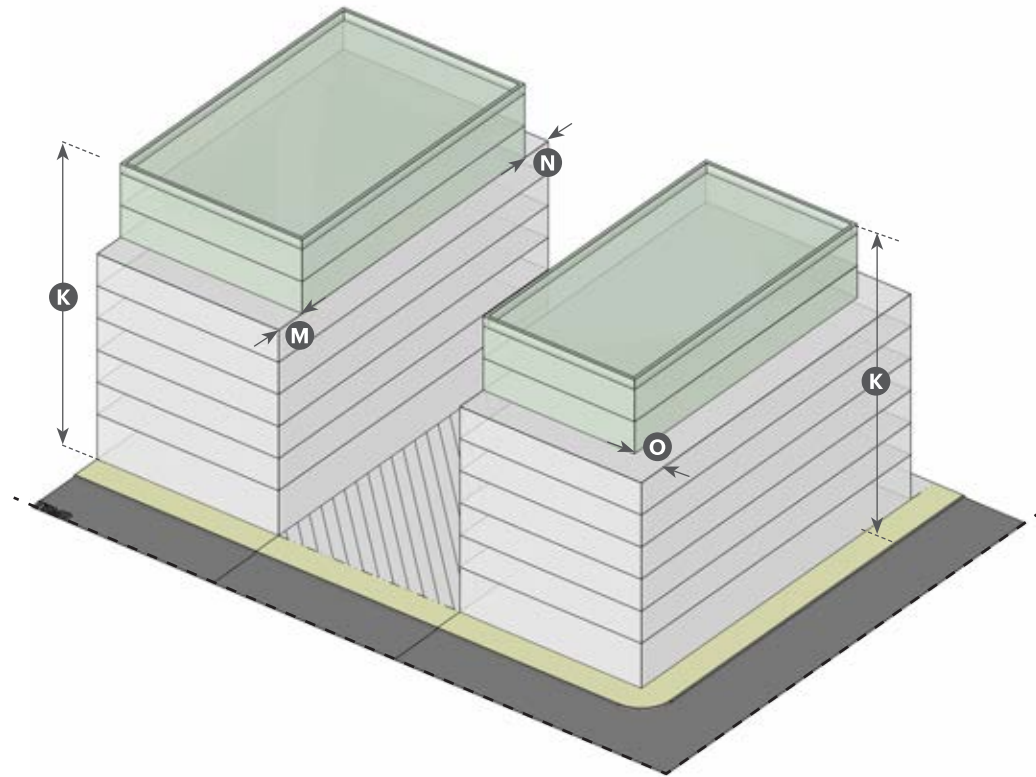

**F. Frontages<sup>1</sup>**

Frontage Type	Front	Side St.	Standards
Forecourt	A	A	3.3.070
Shopfront	A	A	3.3.090
Terrace	A	A	3.3.100
Gallery	A	A	3.3.110

<sup>1</sup> Minimum of one Frontage Type per street-facing facade.

**Key** A = Allowed

**Key**

- Max. Envelope without Height Bonus (Base)
- Max. Envelope with Height Bonus
- Street Centerline

Adjacent to T4N 40/50 and T5N 50/70

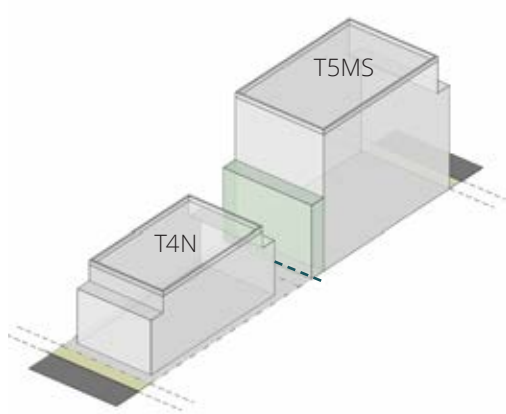

Key

- Main Body
- Rear Stepback
- Rear setback per Sub-Section C (Building Placement)

G. Adjacency Standards

Historic Resource Adjacency

Where adjacent to a designated historic resource refer to DTFBC Section 3.2.070 (Historic Resource Adjacency Standards) in addition to the standards of this zone.

Building Placement and Height

	Setback	Stepback
Where abutting the T4N 40/50		
Rear	10' min.	10' min at 45'

H. Parking		
Required Spaces (min.) for New Buildings <sup>1</sup>		
Use Type	Vehicular Spaces	Bicycle Spaces
Residential Uses		
Studio or 1 Bedroom	0.50	1.0
2 Bedrooms	1.0	2.0
3 or more Bedrooms	1.50	3.0
Non-Residential Uses (amount per tenant in building)		
≤ 2,500 sf	None	
> 2,500 sf	2.75 per 1,000 sf	

<sup>1</sup> For buildings located within the Downtown parking District, the off-street parking requirement is waived for up to 1.0 FAR of the total square footage. For buildings square footage above 1.0 FAR and for all residential uses off-street parking shall be provided. Refer to SRMC Section 14.18.060 (Downtown Parking District).

Setback (Distance from ROW/ Lot Line) <sup>1</sup>		
Front	35' min.	<b>S</b>
Side Street	25' min. when enclosed within building, 5' min. unenclosed <sup>2</sup>	<b>T</b>
Side	0' min.	<b>U</b>
Rear	5' min.	<b>Y</b>

<sup>1</sup> 0' minimum setback for subterranean parking in compliance with frontage requirements.

<sup>2</sup> In compliance with facade zone requirements in Sub-Section C (Building Placement) of this Section.

Driveway		
Driveway Width, within parking setbacks <b>Z</b>		
Front	12' max.	
Side Street/ Alley	20' max.	
Curb Cut	14' max.	

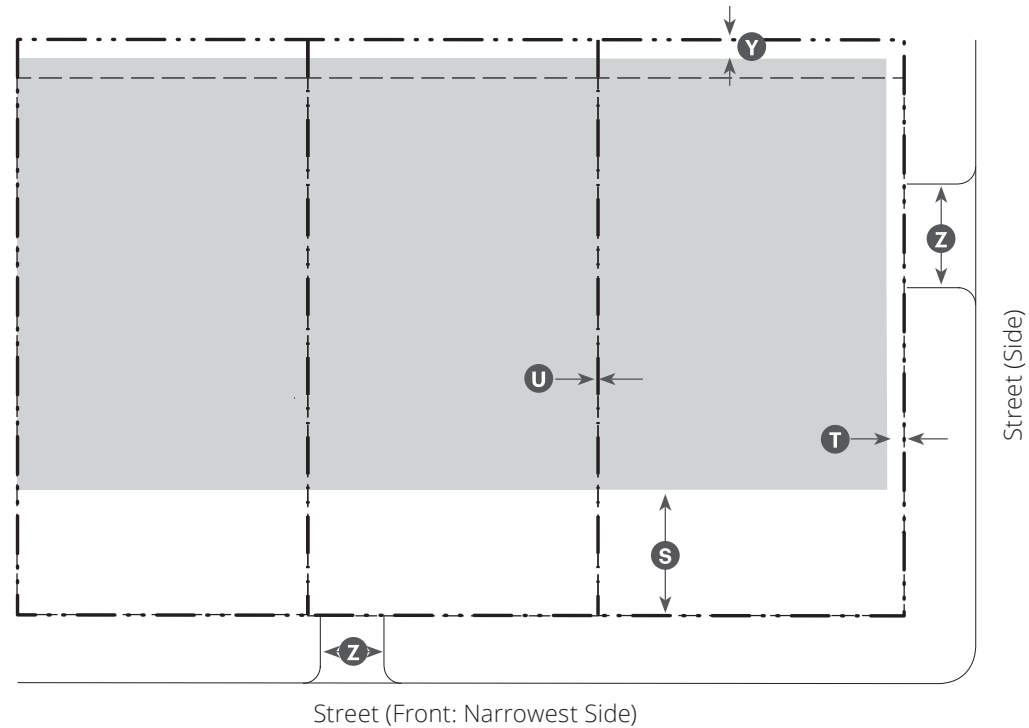

H. Parking (Continued)	
Driveway (Continued)	
Planter (on each side)	2'
Distance between Driveways	40' min.

Curb Cut Width along alley may exceed 12'.

Driveways may be shared between adjacent lots and may exceed max. allowed width by 3'.

Driveways are not allowed in front on a corner lot.

Refer SRMC Section 14.18.040 (Parking Requirements) for dimensions of parking spaces.

**Key**

- ROW/Lot Line
- Building Setback Line
- Parking Area (at or above grade)

### 2.3.070 Use Table

The following table identifies the allowed uses in each zone. All uses are required to be in compliance with frontage of this Chapter and signage standards of SRMC Chapter 14.19 (Signs). The identified permit below is for the use only and shall be processed per City procedures for uses. Individual developments require additional review and approval as identified in DTFBC Table 1.1.050.A (Permit Requirements).

**Uses Not Listed.** Uses not listed are not allowed unless the Director determines that the proposed use is similar to a listed use.

**Existing Buildings.** Existing buildings may be occupied by new uses, allowed in the zone, up to the size of the prior use without requiring additional parking.

Table 2.3.070.A Use Table	Form-Based Zones						
	T4				T5		
	N	N-O	MS	MS-O	N	N-O	MS
<b>Artisanal</b>							
Coffee Roaster	CZ <sup>2</sup>	A <sup>2</sup>	CZ	A <sup>2</sup>	CZ <sup>2</sup>	A <sup>2</sup>	CZ
Tobacco Retailer <sup>4</sup>	C <sup>2</sup>	CZ <sup>2</sup>	C	CZ	C <sup>2</sup>	CZ <sup>2</sup>	C
<b>Automotive</b>							
Motor Vehicle Sales and Services, including automobiles, motorcycles, trailers, trucks and recreational vehicles							
Auto Detailing	CZ <sup>2</sup>	A <sup>2</sup>	-	-	CZ <sup>2</sup>	A <sup>2</sup>	-
Coin-op Washing	C	CZ	-	-	C	CZ	-
Fueling Station <sup>5</sup>	C	C	-	-	C	C	-
Rentals, Vehicle	CZ <sup>2</sup>	A <sup>2</sup>	-	-	CZ <sup>2</sup>	A <sup>2</sup>	-
Repairs Major	C <sup>1</sup>	C <sup>1</sup>	-	-	C <sup>1</sup>	C <sup>1</sup>	-
Repairs, Minor <sup>6</sup>	CZ <sup>1,2</sup>	A <sup>1,2</sup>	-	-	CZ <sup>1,2</sup>	A <sup>1,2</sup>	-
Sales, new or used vehicles	C	CZ	-	-	C	CZ	-
Sales, parts and supplies	P <sup>2</sup>	P <sup>2</sup>	P	P	P <sup>2</sup>	P <sup>2</sup>	P
Sales, tires and ancillary service	CZ	A	-	-	CZ	A	-

**Key** P = Permitted by Right A = Administrative Use Permit CZ = Conditional Use Permit/ Zoning Administrator C = Conditional Permit/ Planning Commission - = Not Allowed

Table 2.3.070.A Use Table (Continued)	Form-Based Zones						
	T4				T5		
	N	N-O	MS	MS-O	N	N-O	MS
<b>Commercial</b>							
Animal Retail Sales, excluding exterior kennel, pen or run <sup>7</sup>	P <sup>2</sup>	P <sup>2</sup>	P	P	P <sup>2</sup>	P <sup>2</sup>	P
Artisan/ Craft Production	P <sup>2</sup>	P <sup>2</sup>	P	P	P <sup>2</sup>	P <sup>2</sup>	P
Building Materials and Supplies <sup>8</sup>	P <sup>2</sup>	P <sup>2</sup>	P	P	P <sup>2</sup>	P <sup>2</sup>	P
Convenience Market <sup>9</sup>	CZ	A	CZ	A	CZ	A	CZ
Grocery Store and Supermarket <sup>9</sup>	P	P	P	P	P	P	P
Gun Shop	-	-	-	-	-	-	-
Kiosk <sup>10</sup>	A <sup>2</sup>	P <sup>2</sup>	A	P	A <sup>2</sup>	P <sup>2</sup>	A
Liquor Store	P <sup>2</sup>	P <sup>2</sup>	P	P	P <sup>2</sup>	P <sup>2</sup>	P
<b>Retail</b>							
Retail General <sup>9,11</sup>	P <sup>2</sup>	P <sup>2</sup>	P	P	P <sup>2</sup>	P <sup>2</sup>	P
Curbside pick up	P	P	P	P	P	P	P
Drive-thru service <sup>24</sup>	-	-	-	-	-	-	-
Secondhand Store, Pawnshop <sup>12</sup>	CZ <sup>2</sup>	A <sup>2</sup>	CZ	A	CZ <sup>2</sup>	A <sup>2</sup>	CZ
<b>Entertainment</b>							
Bar/ Cocktail Lounge/ Nightclub	CZ <sup>2</sup>	A <sup>2</sup>	CZ	A	CZ <sup>2</sup>	A <sup>2</sup>	CZ
<b>Recreational Facility, indoors or outdoors</b>							
Bowling Alley <sup>13</sup>	-	-	-	-	C	CZ	-
Game Center <sup>14</sup>	-	-	C <sup>1</sup>	CZ <sup>1</sup>	C <sup>1</sup>	CZ <sup>1</sup>	-
Poolhalls/ Billiard, Theater <sup>15</sup>	P	P	P	P	P	P	P
<b>Food</b>							
<b>Indoor Eating Area</b>							
Food Service Establishment	P	P	P	P	P	P	P
Food Service Establishments with Alcohol Sales	A	A	P	P	A	A	P
<b>Key</b>	P = Permitted by Right	A = Administrative Use Permit	CZ = Conditional Use Permit/ Zoning Administrator	C = Conditional Permit/ Planning Commission	- = Not Allowed		

	Form-Based Zones							
	T4				T5			
	N	N-O	MS	MS-O	N	N-O	MS	
<b>Food (Continued)</b>								
Curbside pick up	P	P	P	P	P	P	P	
Drive-thru service <sup>16,24</sup>	-	-	-	-	-	-	-	
Outdoor Eating Area <sup>17,1</sup>	A <sup>1</sup>	P <sup>1</sup>	P <sup>1</sup>	P <sup>1</sup>	A <sup>1</sup>	P <sup>1</sup>	P <sup>1</sup>	
<b>Lodging</b>								
Bed and breakfast inn	C	CZ	C	CZ	C	CZ	C	
Hotel/ Motel	C	CZ	C	CZ	C	CZ	C	
<b>Medical Office</b>								
Medical Service	p <sup>2</sup>	p <sup>2</sup>	p <sup>3</sup>	p <sup>3</sup>	p <sup>2</sup>	p <sup>2</sup>	p <sup>3</sup>	
<b>Office</b>								
Laboratory	CZ	A	CZ <sup>3</sup>	A <sup>3</sup>	CZ	A	CZ <sup>3</sup>	
Research and Development	CZ	A	CZ <sup>3</sup>	A <sup>3</sup>	CZ	A	CZ <sup>3</sup>	
Office, General	p <sup>1,2</sup>	p <sup>1,2</sup>	p <sup>1,3</sup>	p <sup>1,3</sup>	p <sup>1,2</sup>	p <sup>1,2</sup>	p <sup>1,3</sup>	
<b>Services</b>								
Animal Care								
Animal Hospital	C	CZ	C <sup>3</sup>	CZ <sup>3</sup>	C	CZ	C <sup>3</sup>	
Indoor/Outdoor kennels	C	CZ	C <sup>3</sup>	CZ <sup>3</sup>	C	CZ	C <sup>3</sup>	
Veterinary Clinic	CZ	A	CZ <sup>3</sup>	A <sup>3</sup>	CZ	A	CZ <sup>3</sup>	
Business Sales and Services	p <sup>2</sup>	p <sup>2</sup>	P	P	p <sup>2</sup>	p <sup>2</sup>	P	
Catering Establishment	P	P	CZ <sup>3</sup>	A <sup>3</sup>	P	P	CZ <sup>3</sup>	
Financial Service and Institution	p <sup>1</sup>	p <sup>1</sup>	p <sup>1,3</sup>	p <sup>1,3</sup>	p <sup>1</sup>	p <sup>1</sup>	p <sup>1,3</sup>	
Hospital/Major Medical Facility	C	CZ	-	-	C	CZ	-	
Outdoor Storage, including temporary or permanent storage containers	CZ	A	-	-	CZ	A	-	
<b>Key</b>	P = Permitted by Right		A = Administrative Use Permit		CZ = Conditional Use Permit/ Zoning Administrator		C = Conditional Permit/ Planning Commission	
	- = Not Allowed							

	Form-Based Zones							
	T4				T5			
	N	N-O	MS	MS-O	N	N-O	MS	
<b>Services, Personal</b>								
Day Care Center (14 or more children or adults)	CZ	A	CZ	A	CZ	A	CZ	
Dry Cleaning Establishment, with on-site processing	CZ	A	CZ	A	CZ	A	CZ	
<b>Family Day Care</b>								
14 children or less, if within residence	P	P	P	P	P	P	P	
Small Day Care Facility, 14 children or less not in a residence	P	P	P	P	P	P	P	
Large Day Care Facility, over 14 children	CZ <sup>1</sup>	A <sup>1</sup>	CZ <sup>1</sup>	A <sup>1</sup>	CZ <sup>1</sup>	A <sup>1</sup>	CZ <sup>1</sup>	
<b>Fitness/ Recreation Facility</b>								
Less than 2,500 sf	P	P	P	P	P	P	P	
2,500 sf or more	A	A	A	A	A	A	A	
Fortunetelling <sup>18</sup>	-	-	A <sup>1,3</sup>	A <sup>1,3</sup>	A <sup>1</sup>	A <sup>1</sup>	A <sup>1,3</sup>	
Funeral and Interment Services, including mortuary, but excluding crematory	CZ	A	-	-	CZ	A	-	
Music Rehearsal/ Recording Studio	CZ	A	CZ <sup>3</sup>	A <sup>3</sup>	CZ	A	CZ <sup>3</sup>	
Personal Service <sup>9,19</sup>	P	P	P	P	P	P	P	
Personal Service, Drive-thru	-	-	-	-	-	-	-	
<b>School</b>								
Parochial, Private	C	CZ <sup>2</sup>	C	CZ <sup>2</sup>	C	CZ <sup>2</sup>	C	
Public	P	P	P	P	P	P	P	
<b>Specialized Education and Training</b>								
Less than 2,000sf	P	P	P	P	P	P	P	
2,000sf or more	CZ	A	CZ	A	CZ	A	CZ	
<b>Key</b>	P = Permitted by Right		A = Administrative Use Permit		CZ = Conditional Use Permit/ Zoning Administrator		C = Conditional Permit/ Planning Commission	- = Not Allowed

	Form-Based Zones						
	T4				T5		
	N	N-O	MS	MS-O	N	N-O	MS
<b>Public Assembly</b>							
Religious Institution (church, temple, mosque, place of worship)	C	CZ <sup>2</sup>	C	CZ <sup>2</sup>	C	CZ <sup>2</sup>	C
<b>Public and Quasi-Public</b>							
Community Garden	P <sup>1</sup>	P <sup>1</sup>	-	-	P <sup>1</sup>	P <sup>1</sup>	-
Club/ Lodge, including youth group	C	CZ	P	P	C	CZ	P
Public Park, Playground, and Recreational Facility	P	P	P	P	P	P	P
Public and Utility Facility	C	CZ	C	CZ	C	CZ	C
Public Facility, Other (Police, Fire Department, Paramedic, Post Office, etc.)	C	CZ	C	CZ	C	CZ	C
<b>Residential</b>							
Accessory Dwelling Unit (ADU)	P	P	P	P	P	P	P
Animal Keeping	A <sup>1</sup>	A <sup>1</sup>	A <sup>1,3</sup>	A <sup>1,3</sup>	A <sup>1</sup>	A <sup>1</sup>	A <sup>1,3</sup>
Boarding House	A	A	A <sup>1,3</sup>	A <sup>1,3</sup>	A	A	A <sup>1,3</sup>
Caretaker's Residence	A	A	A <sup>1,3</sup>	A <sup>1,3</sup>	A	A	A <sup>1,3</sup>
Emergency Shelter for the Homeless							
Temporary	C	CZ	C	CZ	C	CZ	C
Home Occupation <sup>20</sup>	P	P	P <sup>1</sup>	P <sup>1</sup>	P	P	P <sup>1</sup>
Live/ Work <sup>21</sup>	P	P	P	P <sup>1</sup>	P	P	P
Residential <sup>21</sup>	P	P	P <sup>3</sup>	P <sup>3</sup>	P	P	P <sup>3</sup>
Residential Care Facility for the disabled in dwelling unit <sup>21</sup>	P	P	P	P	P	P	P
Residential Care Facility, Other							
Small (0—6 residents)	P	P	P	P	P	P	P
Large (7 or more residents)	C	CZ	C	CZ	C	CZ	C
<b>Key</b>	P = Permitted by Right	A = Administrative Use Permit	CZ = Conditional Use Permit/ Zoning Administrator	C = Conditional Permit/ Planning Commission	- = Not Allowed		



	Form-Based Zones						
	T4				T5		
	N	N-O	MS	MS-O	N	N-O	MS
<b>Temporary Use</b>							
Temporary Use <sup>22</sup>	A <sup>1</sup>	A <sup>1</sup>	A <sup>1</sup>	A <sup>1</sup>	A <sup>1</sup>	A <sup>1</sup>	A <sup>1</sup>
<b>Transportation</b>							
Bus Station	-	-	-	-	C	CZ	C
"Park and Ride" Facility	CZ	A	-	-	CZ	A	CZ
Parking Facility, commercial or municipal	CZ	A	CZ	A	CZ	A	CZ
Rideshare Station <sup>23</sup>	C	CZ	-	-	C	CZ	C
Transit Station, public or transitway	C	CZ	-	-	C	CZ	C
<b>Other Uses</b>							
Wireless Telecommunication Facilities <sup>25</sup>	A	A	A	A	A	A	A

<sup>1</sup> See SRMC Chapter 14.21 (Administrative Use Permits) Performance Standards for additional requirements.

<sup>2</sup> Max. 2,500 sf per building.

<sup>3</sup> Not allowed on the ground floor within 30' of the sidewalk. Allowed on ground floor along side street if at least 15' from the front of the lot.

<sup>4</sup> Shall not be located within one thousand feet (1,000') from: schools (public and private elementary, junior high, and high schools), public parks, public libraries, arcades, youth/teen centers, community/recreation centers, licensed day care centers for children, shopping malls, and houses of worship with organized youth programs, as measured from the property lines of each parcel.

<sup>5</sup> See SRMC Section 14.16.160 (Gasoline Stations)

<sup>6</sup> See SRMC Section 14.17.090 (Motor Vehicle Repair Uses)

<sup>7</sup> See SRMC Chapter 10.24 (Dog Kennels and Pet Shops)

<sup>8</sup> See SRMC Section 14.17.120 (Outdoor Storage)

<sup>9</sup> Operating after eleven p.m. (11:00 p.m.) requires a use permit (CZ)

<sup>10</sup> See SRMC Section 14.16.115 (Emergency Shelters - Permanent)

<sup>11</sup> See SRMC Chapter 10.16 (Auctions)

<sup>12</sup> See SRMC Chapter 10.20 (Pawnbrokers and Secondhand Dealers)

<b>Key</b>	P = Permitted by Right	A = Administrative Use Permit	CZ = Conditional Use Permit/ Zoning Administrator	C = Conditional Permit/ Planning Commission	- = Not Allowed
------------	------------------------	-------------------------------	--	--	-----------------

---

<sup>13</sup> See SRMC Chapter 10.32 (Bowling Alleys)

---

<sup>14</sup> See SRMC Section 14.17.070 (Game Arcades)

---

<sup>15</sup> CZ applies if there is a liquor sales use with no food service.

---

<sup>16</sup> This use allowed in West End Village and Montecito Commercial.

---

<sup>17</sup> For outdoor eating areas on private property, see SRMC Section 14.17.110 (Outdoor Eating Areas Proposed in Conjunction with Food Service Establishments) standards. For outdoor seating areas located on city sidewalks or rights-of-way, see SRMC Section 14.16.277 (Use Of City Sidewalks and Rights-of-way for Outdoor Eating Areas) standards.

---

<sup>18</sup> See SRMC Section 14.17.060 (Fortunetelling)

---

<sup>19</sup> See SRMC Chapter 8.34.

---

<sup>20</sup> See SRMC Section 14.16.220 (Home Occupations)

---

<sup>21</sup> See SRMC Section 14.17.100 (Residential Uses in Commercial Districts)

---

<sup>22</sup> See SRMC Section 14.17.130 (Temporary Uses)

---

<sup>23</sup> See SRMC Chapter 10.60 (Vehicles for Hire)

---

<sup>24</sup> Existing as of December 31, 2020.

---

<sup>25</sup> Subject to stealth design requirements.

*This page intentionally left blank*





# Supplemental to Downtown Form-Based Zones

ARTICLE

3

# Division 3.1 Site Standards

## 3.1.010 Purpose

These standards are intended to ensure that development of property within form-based zones accomplishes the following:

- Makes a positive contribution to the development pattern of the area;
- New or altered structures are compatible with the scale, design and use of existing structures on neighboring properties;
- Respects the existing conditions and safety of neighboring properties; and
- Does not adversely affect neighboring properties, with "adversely affect" meaning to impact in a substantial, negative manner the habitability or enjoyability of these properties.

## 3.1.020 Screening

This Section prescribes standards for screening, fences, and walls for the conservation and protection of property, the assurance of safety and security, the enhancement of privacy, the attenuation of noise, and the improvement of the visual environment of the neighborhood.

## Design Standards for Screening

Screening shall comply with the following:

- **Maximum Screening Height.** Screening shall not exceed the maximums identified in DTFBC Table 3.1.020.A (Maximum Screening Height).
- **Screening Height Measurement.** Screening height shall be measured as the vertical distance between the finished grade at the base of the screen and the top edge of the screen material.

## Additional Screening Requiring Director Approval

In compliance with the standards, the following screening types require Director approval.

**Courtyard.** Along a street or civic space, fences, walls and other screening installed to create a courtyard without a roof shall not exceed four feet in height and be set back a minimum of 10 feet from the front property line or back of sidewalk, whichever is the least. In reviewing the plan for the proposed courtyard, the Director shall consider, but not be limited to, the following:

- Building characteristics including the dimensions, color and architectural design;
- Compatibility of the architectural and design features of the proposed courtyard with the features of the adjoining, as well as neighboring buildings; and

Table 3.1.020.A Maximum Screening Height

Zone	Item	Max. Screen Height within Required Setbacks			
		Front	Side St.	Side	Rear
T4 Neighborhood (T4N 30/40 and T4N 40/50)	Fences	3' max.	3' max.	9' max.	9' max.
	Free Standing Walls	3' max.	3' max.	9' max.	9' max.
	Shrubs	4' max.	4' max.	A	A
T4 Main Street (T4MS 40/50, T4MS 40/60, T4MS 50/70 and T4MS 60/80)	Fences	X	X	9' max.	9' max.
	Free Standing Walls	X	X	9' max.	9' max.
	Shrubs	3' max.	3' max.	A	A
T5 Neighborhood (T5N 40/60 and T5N 50/70)	Fences	3' max.	3' max.	9' max.	9' max.
	Free Standing Walls	3' max.	3' max.	9' max.	9' max.
	Shrubs	3' max.	3' max.	A	A
T5 Main Street (T5MS 70/90)	Fences	X	X	9' max.	9' max.
	Free Standing Walls	X	X	9' max.	9' max.
	Shrubs	3' max.	3' max.	A	A

**Key**

A = Allowed

X = Not Allowed

- Landscaping, including the effort to minimize removal of existing vegetation and to match replacements with vegetation of the site.

**Screening on Retaining Walls**

The total height of screens and the retaining walls that they are mounted on or attached shall not exceed six feet. However, the Director may approve higher screening if it is determined that there will be little or no impact on the adjoining properties or the surrounding neighborhood and the height is necessary to achieve the objectives of this Sub-Section or is required for health and safety.

**Mechanical Equipment Screening**

The following equipment is exempt from screening requirements:

- Free-standing or roof-mounted solar equipment; and
- Vents less than four feet in height subject to Director review.

**Roof-Mounted Equipment.** Building parapets or other architectural elements in the building's architecture style shall screen roof-mounted equipment.

- New buildings shall be designed to provide a parapet or other architectural element that is as tall or taller than the highest point on any new mechanical equipment to be located on the roof of the building; and
- For existing buildings with no parapet or low parapet heights, mechanical equipment shall be surrounded on all sides by an opaque screen wall as tall as the highest point of the equipment. The wall shall be architecturally consistent with the building and match the existing building with paint, finish, and trim cap detail. All new

roof screens are subject to Director review and approval and may be referred to the Planning Commission, as determined by the Director.

#### **Wall- and Ground-Mounted Equipment**

- The equipment is not allowed between the face of the building and the street;
- All screen devices shall be as high as the highest point of the equipment being screened. Equipment and screening shall be in compliance with the setbacks of the zone;
- Screening shall be architecturally compatible and include matching paint, finish and trim cap of the building; and
- All new mechanical screens for ground or wall-mounted equipment are subject to Director review and approval.

#### **Temporary Fencing**

Temporary fencing may be used to provide security for approved special events, construction sites, or vacant structures and land, which cannot otherwise be secured. All temporary fencing shall:

- Consist of chain link fencing or other materials as approved by the Director;
- Not exceed six feet in height;
- Be removed at the conclusion of the special event or completion of construction activities (i.e. final inspection) for which it was approved; and
- All approved fencing for construction sites shall not be installed until a Building Permit or Grading Permit has been issued and shall be removed prior to final inspection. The use of temporary fencing around occupied structures that can be secured by other means is prohibited. The use of temporary fencing around vacant land or vacant structures is subject

to the terms and conditions specified in the Permit authorizing the fencing.

#### **Barbed Wire and Razor Wire**

Barbed Wire and Razor Wire screening is not allowed.

#### **Safety**

Fences, walls, and other screening and landscaping shall be in compliance with the following:

Maximum height of four feet within 10 feet of the point of intersection of:

- A vehicular access way or driveway and a street; and/or
- A vehicular access way or driveway and a sidewalk.

Two or more vehicular access ways, including driveways, alleys, or streets.

As used in this Sub-Section, "point of intersection" is measured from the face of curb or if none, from the edge of pavement.

### **3.1.030 Landscaping and Lighting**

This Section prescribes landscaping standards for protection and enhancement of the environmental and visual quality of the Downtown, enhancement of privacy, and the control of dust.

#### **Required Landscaping**

The landscaping required by this Sub-Section shall be installed as part of the development or improvement requiring the landscaping. Standards for landscaping in parking areas shall be in combination with DTFBC Section 3.1.040 (Parking and Loading).

#### **Standards for Landscape Plans**

Landscaping Plans are required for development in all form-based zones.



### Design Standards

Acceptable required landscaping materials are defined as follows:

- Shrubs, of one-gallon size or larger;
- Trees, including street trees, of 15-gallon size or larger, and double-staked;
- Ground cover; and
- Decorative nonliving landscaping materials including, but not limited to sand, stone, gravel, wood or water may be used to satisfy a maximum of 25 percent of required landscaping area when approved by the Director.

**Species Selection.** Native and drought tolerant species are required to meet the minimum standards, in conformance with MMWD Water Conservation Ordinance 414.

**Separation.** Any landscaped area shall be separated from an adjacent vehicular area by a wall or curb at least six inches higher than the adjacent vehicular area. The curb shall include inlets from the parking surface to collect rainwater.

**Existing Vegetation.** Every effort shall be made to incorporate mature on-site trees into the required landscaping, subject to approval by the Director.

**Maintenance.** Required landscaping shall be maintained in a neat, clean and healthy condition. This shall include pruning, weeding, removal of litter, fertilizing, replacement of plants when necessary, and the appropriate watering of all plantings.

### Lighting Standards

Refer to SRMC Section 14.1.170 for guidance on lighting standards for Downtown development.

### 3.1.040 Parking and Loading

This Section prescribes standards for and limits on the development of motor vehicle and bicycle parking, loading and access drives; and standards for reducing motor vehicle trips per capita to and from development. These standards are intended to ensure that development of property within form-based zones accomplishes the following:

- Establishes and/or reinforces the character and scale of walkable, urban neighborhood environments, where development supports and is within a short walking distance of retail and services;
- Ensures the provision of appropriately designed bicycle parking, in order to increase bicycle trips and reduce motor vehicle trips per capita;
- Appropriately limits, screens and landscapes motor vehicle parking, in order to protect and enhance the environmental and visual quality of the Downtown, enhance privacy, attenuate noise, and control dust; and
- Reduces motor vehicles trips per capita to and from development.

#### General Parking Standards

**On-Site Parking.** Sharing of parking between different land uses and developments is allowed subject to approval by the City per SRMC Section 14.18.080 (Parking Requirements for Reciprocal Uses with Shared Parking Facilities).

#### Larger Vehicle Parking

- Trucks, tractors or tractor-trailers having a capacity of more than a one-and-one-half-ton load, front- and rear-end loaders, or any kind of commercial, industrial, agricultural or transportation vehicles/ equipment used primarily for business purposes, shall not be parked or

stored in any zone for purposes other than unloading, loading or delivery services.

- Automobiles, small trucks, vans, vehicle trailers allowed in conjunction with an approved home occupation (one per home occupation), and recreational vehicles, utilized for personal or business use, are excluded from the provisions of this Sub-Section.

**Storage of Unregistered or Inoperable Motor Vehicles.**

Automotive vehicles, trailers, or vehicles of any kind or type, requiring licenses, but without current plates or inoperable, shall be only parked within completely enclosed buildings.

**Cargo or Freight Container.** Portable cargo or freight storage containers in any zone for purposes of loading or unloading, may be parked or stored on-premise for a period not to exceed 10 days in any one calendar year.

**Commercial Auto Repairs.** New businesses offering commercial repair service and/or restoration of vehicles are not allowed.

**Number of Motor Vehicle Parking Spaces Required**

The maximum number of parking spaces required is listed in DTFBC Sub-Section H (Parking) of the zone. For any use not listed in that Item, parking shall not exceed a ratio equivalent to the average peak parking occupancy rate for the most comparable use in the Institute of Transportation Engineers Parking Generation Manual. The Director required shall determine the most comparable use.

**Required Number of Parking Spaces in Form-Based Zones.** When calculating the required number of parking spaces, numbers shall be rounded to the closest whole number. Parking systems that stack individual vehicles are counted as three spaces for every horizontal space identified.

**Exception in the Event of Changes of Use or Alterations to Existing Buildings or Structures.** If an existing building or structure is altered or existing land uses are changed, the existing number of parking spaces on a property may be retained, even if the resulting building, structure or land use would ordinarily be subject to a lower maximum parking allowance.

**Electric Vehicle Charging**

Electric vehicle charging facilities shall be provided in compliance with SRMC Section 14.18.045 (Designated Parking for Clean Air Vehicles).

**Traffic-Minimizing Parking Standards**

**Carshare Parking Spaces**

- Carshare parking spaces shall be provided in the amounts specified in DTFBC Table 3.1.040.A (Required Carshare Parking Spaces).
- The required carshare space(s) shall be made available, at no cost, to a carshare service for purposes of providing carshare services to its members. At the election of the property owner, the carshare spaces may be provided:
  - On the lot; or
  - On another off-street site within 800 feet of the lot.
- Required carshare space or spaces shall be designed in a manner that will make the spaces accessible to non-resident subscribers from outside the building as well as building residents.
- Prior to City approval a building subject to the carshare standard, a Notice of Special Restriction on the property shall be recorded indicating the nature of standards of this Sub-Section and identifying the minimum number and location of the required carshare parking spaces. The form of the notice and the location or locations of

**Table 3.1.040.A Required Carshare Parking Spaces**

Use	Carshare Parking Spaces Required
Residential	
0-49 Units	None
50-100 Units	1
101 or more Units	2 + 1 per additional 200 Units

Office/ Research and Development	
≤ 10,000 sf	None
> 10,000 sf	1/10,000 sf

the carshare parking spaces shall be approved by the City.

- If it is demonstrated to the satisfaction of the City that no carshare service can make use of the dedicated carshare parking spaces, the spaces may be occupied by non-carshare vehicles; provided, however, that upon 90 days of advance written notice to the property owner from a carshare service, the property owner shall terminate any non-carsharing leases for such spaces and shall make the spaces available to the carshare service for its use of such spaces.

**Carpool Spaces.** If parking is provided at a development, parking spaces reserved for use by carpool/ vanpool vehicles shall be designated in preferred locations (include, but are not limited to closest building entries). The locations of these spaces shall be approved by the City. The minimum number of carpool spaces required is

listed in DTFBC Table 3.1.040.B (Required Carpool Parking Spaces).

**Parking Costs Unbundled from the Cost of Other Goods and Services**

- **Residential Uses.** All off-street parking spaces accessory to residential uses in structures of four dwellings or more shall be leased or sold separately from the rental or purchase fees for dwellings for the life of the dwellings. It is the applicants' responsibility to provide renters or buyers of on-site inclusionary affordable units with an equal opportunity to rent or buy a parking space on the same terms and conditions as offered to renters or buyers of other dwellings.
- **Exception.** The Director may grant an exception from this standard for developments which include financing

**Table 3.1.040.B Required Carpool Parking Spaces**

Use	Carpool Parking Spaces Required
Office/ Research and Development	
≤ 10 Parking Spaces	None
> 10 Parking Spaces	10% of the total number of Spaces
All other Uses	None

for affordable housing that requires that costs for parking and housing be bundled together.

- **Non-Residential Uses.** All off-street parking spaces accessory to non-residential uses may be leased or sold separately from the rental or purchase fees for non-residential building space for the life of the building, such that potential renters or buyers have the option of renting or buying building space at a price lower than would be the case if there were a single price for both the building space and the parking space.
- **Exception.** Off-street parking spaces accessory to retail uses are not required to be leased or sold separately from retail space and may be offered to shoppers and other visitors free of charge for stays of up to two hours.

**Parking Spaces, Lot Design and Layout**

**Access.** The following standards are applicable to on-site parking lot access design:

- All on-site parking facilities shall be designed with an appropriate means of vehicular access to a street or to an alley to cause the least interference with traffic flow.
- Parking spaces in any parking lot or parking structure shall not be designed or located so as to allow a vehicle to enter or exit a parking space directly from a public street. Ingress to and egress from parking spaces shall be from an on-site aisle or driveway, except parking spaces within lots may be designed or located so as to allow a vehicle to enter or exit a parking space directly from a public alley or rear lane.
- On-site loading space(s) is not required.

**Driveway.** Access

- Driveway access to and from developments of two or fewer dwellings onto public streets shall be, where practical, by forward motion of the vehicle; and

- Driveway access to and from developments of three or more dwellings onto public streets shall be by forward motion of the vehicle.

Driveways shall extend to and include the area between the lot line and the edge of the street pavement.

The design and construction of all on-site parking access driveways shall meet City Standards.

**Identification as to Purpose and Location.** On-site parking areas of four or more spaces shall include painted lines, wheel stops, or other methods of identifying individual parking spaces and loading areas, while distinguishing such spaces from aisle and other circulation features.

**Materials**

- All on-site parking areas and driveways shall be surfaced with materials as approved by the City Engineer and maintained in compliance with the City Standards.
- The use of pervious or semi-pervious parking area surfacing materials, include, but are not limited to “grasscrete,” or recycled materials including, but not limited to glass, rubber, used asphalt, brick, block and concrete, is subject to approval by the Director and City Engineer. Where possible, such materials should be used in areas in proximity to and in combination with on-site stormwater control devices.

**Landscaping, Fencing, and Screening.** The landscaping, fencing and screening standards identified in DTFBC Table 3.1.040.C (Required Parking Lot Landscaping) shall be applied with the standards of DTFBC Section 3.1.020 (Screening) and DTFBC Section 3.1.030 (Landscaping).

- Parking and loading areas shall be screened from adjacent residential zones by a six foot wall, fence, or evergreen, subject to approval by the Director.

- Screening is not required when parking area(s) is adjacent to an alley.
- Landscaping areas shall accommodate stormwater management features to the extent feasible as determined by the City.
- For the portion of a parking area over which photovoltaic solar collectors are installed where they also function as shade structures, the minimum standard for trees shall be waived, and shrubs and ground covers shall be planted for every eight parking spaces.

Refer also to SRMC Section 14.18.160 for guidance on screening standards as applicable to the Downtown Zones.

**Location.** Location of required on-site parking in all zones is regulated by setbacks set forth in DTFBC Sub-Section H (Parking) of the zone and the following:

- Parking lots with 20 or fewer spaces shall have all on-site parking areas separated at least five feet from buildings in order to provide a sidewalk between the building and the parking area;
- Parking lots with more than 20 spaces shall have all on-site parking areas separated at least 10 feet from buildings in order to make room for a sidewalk, landscaping, and other planting between the building and the parking area; and

**Table 3.1.040.C Required Parking Lot Landscaping**

Number of Parking Spaces	Percent of Gross Parking Area Required to be Landscaped
6 or fewer	5' min. wide planter between lot line, building(s)
7 to 15	4%; 5' min. wide planter between lot line, building(s)
16 to 30	8%; 5' min. wide planter between every 5 spaces, lot line, building(s)
31 to 70	12%; 5' min. wide planter between every 5 spaces, lot line, building(s)
71 and over	16%; 5' min. wide planter between every 5 spaces, lot line, building(s)
Required Shade Trees	
Amount	1 tree per 2,700 sf of gross lot area, minus building coverage (footprint)
Box Size/ Quantity	24" min. size for 20% min. of total trees
Can Size/ Quantity	15 gallon for 80% max. of total trees
Height Clearance	6-8" min. along pedestrian paths
Characteristics	High branching, broad headed, shading form
Required Border	6" high curb or equivalent
Border and Stormwater	Curb shall include breaks every 4" to provide drainage to retention and filtration areas
Tree Well Size <sup>1</sup>	5' x 5' min.
Car Overhangs	Limited to 12" max. by curb or wheel stops

<sup>1</sup>Any vehicle overhang requires the minimum planter area width to be expanded by an equivalent dimension.

- This separation may be eliminated to the rear of buildings in areas designed for unloading and loading of materials.

**Size of Parking Lot.** Parking lots larger than one-quarter of an acre in size shall be broken down into smaller parking areas with planted landscape areas with a minimum width of 15 feet between them to minimize the perceived scale of the total field of stalls.

**Tandem Parking.** Tandem parking is allowed in all zones for all uses.

**Bicycle Parking Standards.** Bicycle parking is required in all zones and subject to the standards in SRMC Section 14.18.090 (Bicycle Parking).

### 3.1.050 Block Size Standards

This Section establishes standards for the maximum size of new or modified blocks in the Plan boundaries to maintain Downtown's fine-grained network of walkable blocks and streets.

Table 3.1.050.A Block Size Standards		
All Zones		
	Without Paseo	With Paseo <sup>1</sup>
Block Face Length	500' max.	600' max.
Perimeter	2,000' max.	2,400 max.

<sup>1</sup>Paseo must be at least 20' wide and is subject to design review.

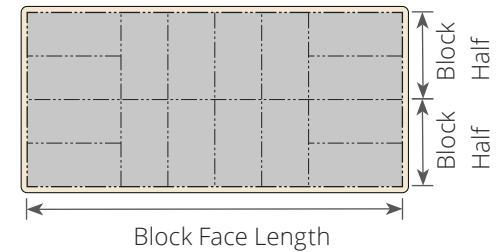

Figure 3.1.050.A Block Size

*This page intentionally left blank*

# Division 3.2 Massing and Facade Articulation Standards

### 3.2.010 Purpose

The following standards are intended to promote local prevalent patterns that strongly contribute to the Downtown's unique physical character while allowing for creativity and innovation.

### 3.2.020 Overview of Massing and Facade Articulation Standards

**Massing and Facade Articulation Standards.** As required by DTFBC Table 3.2.020.A (Massing and Facade Articulation Standards Overview), facades on a street or civic space shall be designed in compliance with the standards identified in this Section.

DTFBC Table 3.2.020.A (Massing and Facade Articulation Standards Overview) provides an overview of the requirements.

**Table 3.2.020.A Massing and Facade Articulation Standards Overview**

Requirement	Building length along adjacent sidewalk <sup>1</sup>			
	< 75'	75' to 100'	>100'	>150'
3.2.030 (Tripartite Facade Articulation)	No	Yes	Yes	Yes
3.2.040 (Massing and Composition)	Yes	Yes	Yes	Yes
3.2.050 (Corner Elements)	No	No	No	Yes
3.2.060 (Windows and Openings)	Yes	Yes	Yes	Yes
3.2.070 (Historic Resource Adjacency Standards)	Required where adjacent to identified historic resource			

<sup>1</sup> As measured along street or adjacent civic space.



### 3.2.030 Tripartite Facade Articulation



The top of the building is articulated with an entablature and parapet wall, Image source: [www.719larkin.com](http://www.719larkin.com)



Example of a distinct base, middle, and top.

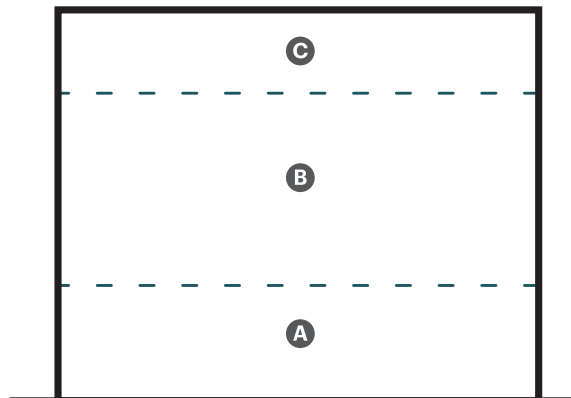

Diagram of tripartite facade articulation.

#### A. Description

New facades and facade modifications along a street or civic space shall be designed to visually express a base, middle, and top.

#### B. Applicability

New buildings and facade modifications over 75' in length along the adjacent street or civic space.

#### C. Standards

Ground Floor/ Distinct Base <sup>1</sup>	<b>A</b>
Middle	<b>B</b>
Top <sup>2</sup>	<b>C</b>

Combinations of colors, materials, and massing may be used to visually express a base, middle, and top.

<sup>1</sup>The base may include multiple stories.

<sup>2</sup>The top may include multiple stories. Note that upper stories that are stepped back do not count as part of the "top". To articulate the top, count only stories that are not stepped back from the "base" and "middle" of the building facade.

General Note: Photos on this page are illustrative, not regulatory.

### 3.2.040 Massing and Composition



Illustrative example.



Illustrative example, Image source: [www.realtors.com](http://www.realtors.com)



Illustrative example.

#### A. Description

New facades and facade modifications along a street or civic space shall be designed to appear as multiple buildings no greater than 75' in length.

#### B. Applicability

New buildings and facade modifications.

#### C. Standards/ General Character

Building facades shall be arranged in an orderly composition of window bays/openings based on prevalent patterns of 5, 7 or 9 bays. **A**

Facades shall be designed in an orderly symmetrical or asymmetrical composition.

Compositions (symmetrical) **B**

Compositions (asymmetrical) **C**

The pattern shall be visually expressed through the spacing of openings, physical recesses, projections or other techniques.

The pattern may include the ground floor and its mezzanine.

General Note: Photos on this page are illustrative, not regulatory.

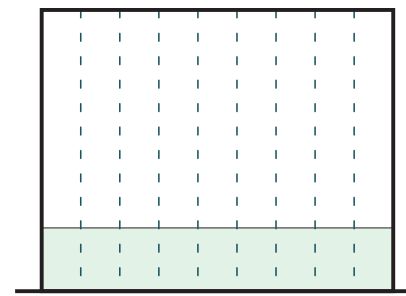
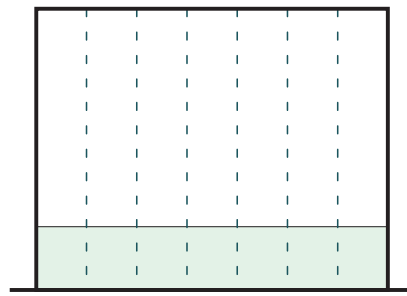
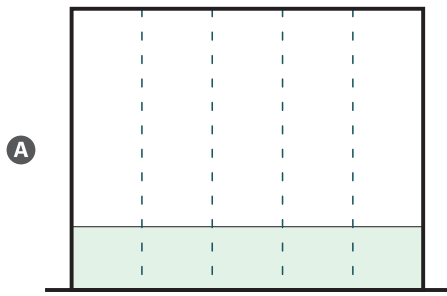

Examples of 5, 7, 9 Bay Openings.

**B** Examples of Symmetrical Compositions.

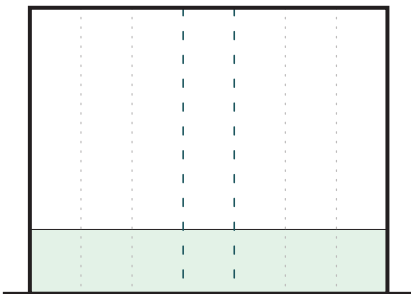
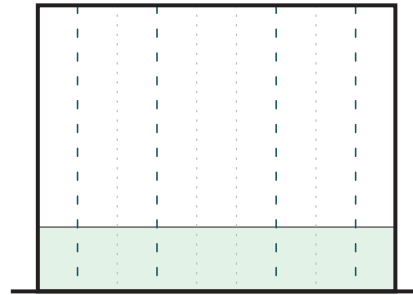
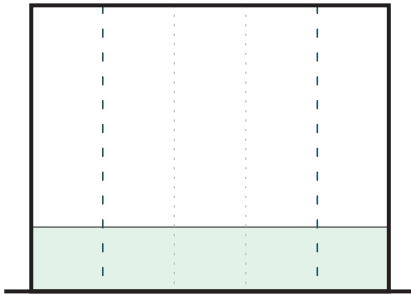

**C** Examples of Asymmetrical Compositions.

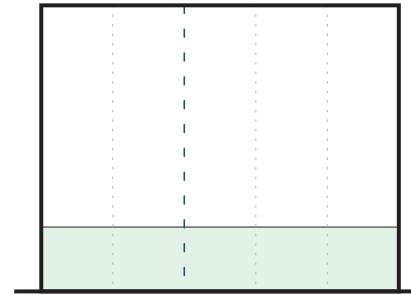

Elevation



Plan

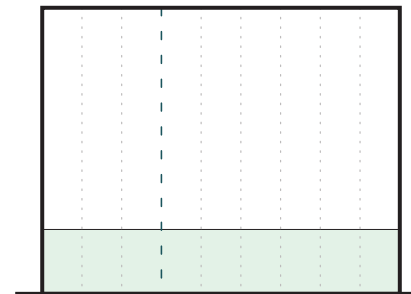

Elevation



Plan

### 3.2.050 Corner Elements



Example of Corner Element, Image source: [www.sitephocus.com](http://www.sitephocus.com)



Example of an upper story Corner Element.



Example of an upper story Corner Element.

#### A. Description

New facades and facade modifications shall be designed to include a corner element to give visual importance to the corner and enhance the public realm.

#### B. Applicability

New buildings and facade modifications where at least 1 facade along a street corner is over 150' in length.

#### C. Standards/ General Character

- Square (A)
- Octagonal (B)
- Chamfer (C)

Only one corner element is required per eligible facade.

Corner elements shall incorporate at least 1 entire story within the composition and may extend from the ground floor through the top of the building.

Corner elements may exceed the maximum height allowed for the building by up to 10' for a horizontal area up to 20' x 20', only in cases where the top story is at the maximum allowed height.

Corner elements may be recessed or projected from the main facade by up to 4'. Projections over the right of way are allowed when at least 12' above the adjacent sidewalk. (D)

General Note: Photos on this page are illustrative, not regulatory.

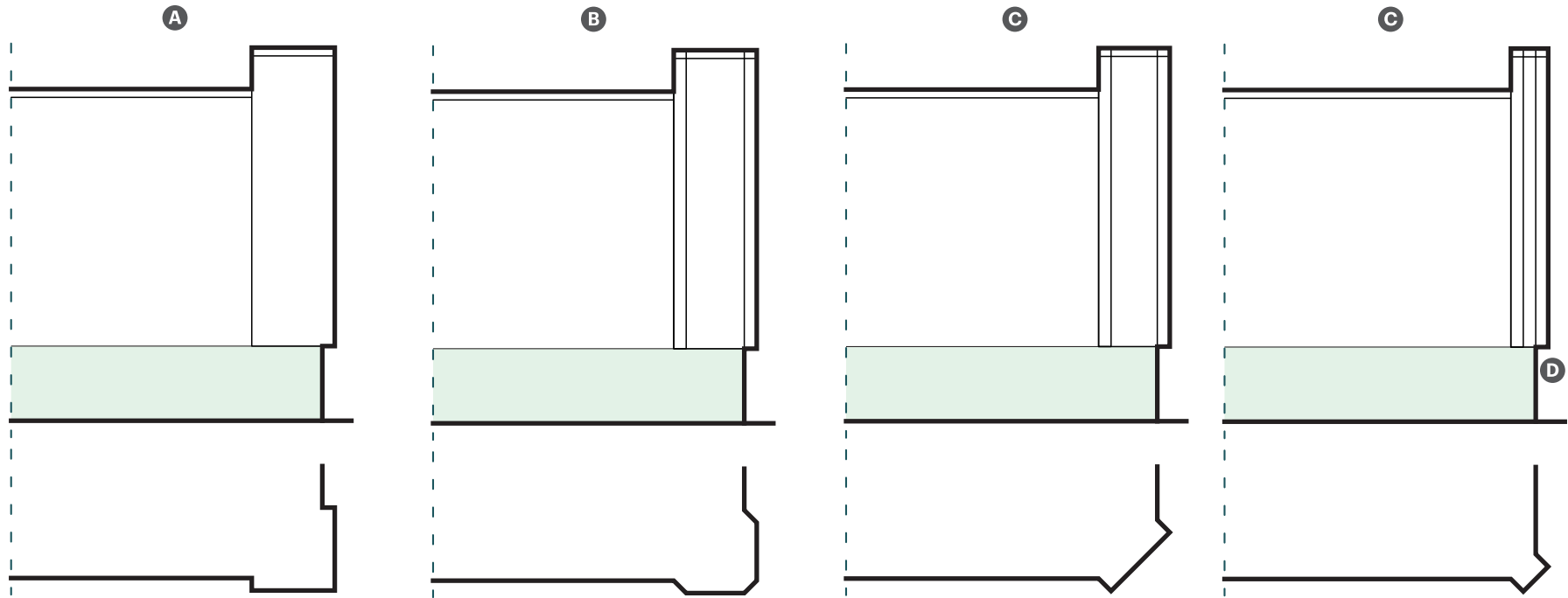

Plan and elevation diagrams of Corner Elements.

### 3.2.060 Windows and Openings



Examples of vertical oriented Bay Windows and Openings.



Example of Square Bay Window.

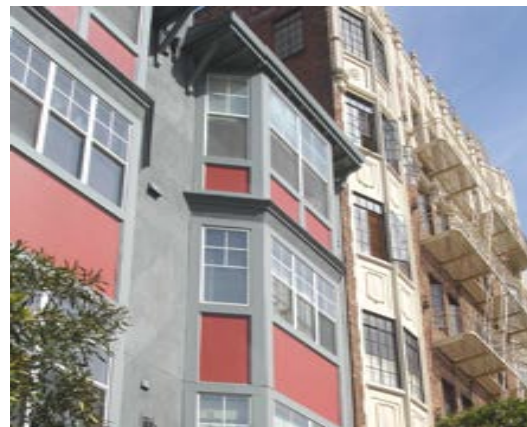

Example of Chamfer Bay Window.

#### A. Description

New facades and facade modifications shall be designed to include an orderly composition of window bays and openings.

#### B. Applicability

All new buildings and facade modifications.

#### C. Standards/ General Character

Buildings 100' or more in length along the street are required to include projected or recessed window bays, and shall be designed per Item A below. The recess may be achieved by a partial or complete window surround. Upto 3 bays may be grouped.

Allowed patterns for buildings at least 100' long:

Bay Windows:

- Square
- Chamfer

- A**
- a**
- b**

Required stepbacks may be replaced by mansard roof forms with windows as follows:

- 30' to 50' overall height      Single Mansard **B**
- 50' to 90' overall height      Single Mansard **B** or  
Double Mansard **C**

Mansard roof forms are exempt from stepbacks.

Mansard roofs can include a maximum of 2 stories and must include the uppermost story.

All buildings facades shall be designed to include square or vertically - oriented windows and openings.

Windows may be grouped but the overall grouping shape is required to be square or vertical, except on shopfronts.

Facades within 1 block of a building with recessed windows and/or openings are required to include recessed windows with at least 4" of recess for at least 25% of the new or modified facade.

*General Note: Photos on this page are illustrative, not regulatory.*

Bay Windows

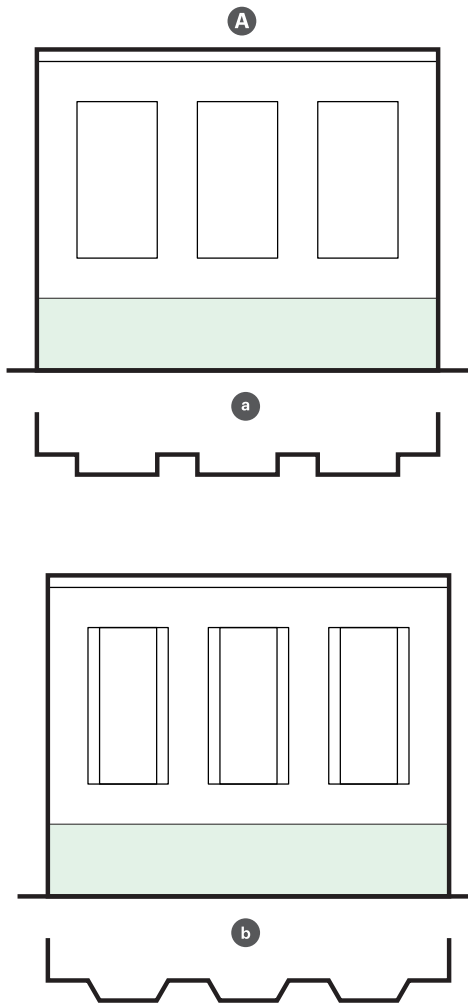

Mansard Roof Forms

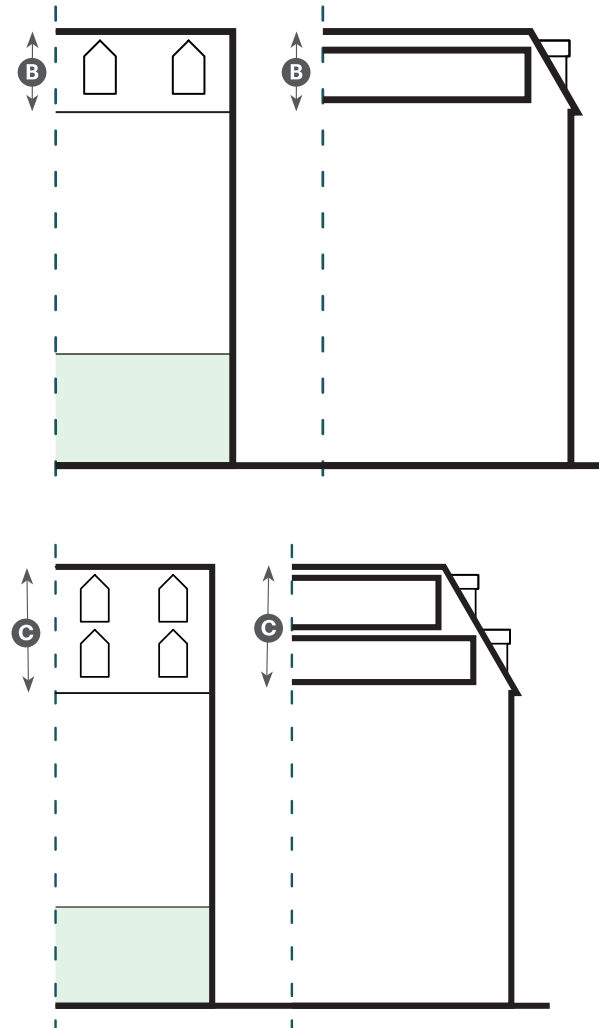

Examples of vertical and rectangular Window Compositions, Images source: [www.flirck.com](http://www.flirck.com), Jay Sterlin



Example of Mansard Windows.

### 3.2.070 Historic Resource Additions and Adjacency Standards

Any new building or proposed modification on or immediately adjacent to a historic resource identified in DTFBC Figure 2.2.040.A (Regulating Plan) shall be designed in compliance with the additional massing standards identified in this Section. All new construction within the Historic Districts shown in DTFBC Figure 2.2.040.A (Regulating Plan) is considered adjacent to a resource and thus it needs to follow the standards of this Section. Additional height and/or building width/depth is possible if supported by the recommendation of the City's

Architectural Historian and Design Review. The provisions of this section shall not apply to parcels outside of eligible historic districts unless they are adjacent to historic district boundaries or are adjacent to buildings outside the districts that are identified as "individual resources" on Figure 5.6 of the Precise Plan. In addition, the limitations on upper story additions shall only apply to historic resources within eligible districts and to buildings outside the districts that are identified as "individual resources" on Figure 5.6 of the Precise Plan.

**Table 3.2.070.A Historic Resource Adjacency Standards**

**1. All New Buildings Immediately Adjacent to a Block-Form Historic Resource**

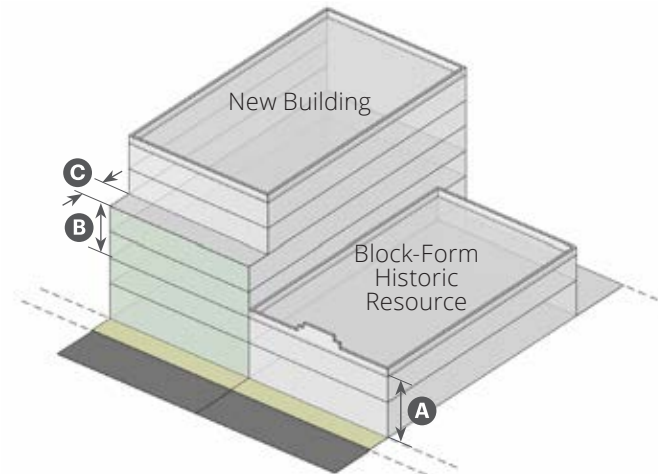

Required stepback for upper floors at maximum 20' above the height of the adjacent block-form historic resource.

- Height of existing historic resource A
- Maximum 20' height above height of historic resource B
- Minimum 10' stepback. Beyond stepback, maximum heights as allowed by zone standards. C

New building must comply with all standards of the zone.

**2. All New Buildings Immediately Adjacent to a House-Form Historic Resource**

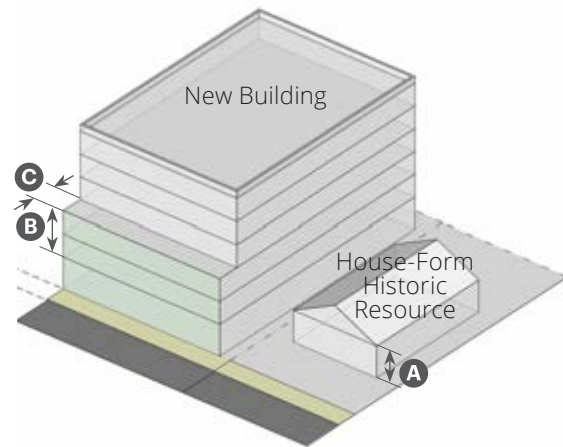

Required stepback for upper floors at maximum 20' above the height of the adjacent house-form historic resource.

- Height of existing historic resource A
- Maximum 20' height above height of historic resource B
- Minimum 10' stepback. Beyond stepback, maximum heights as allowed by zone standards. C

New building must comply with all standards of the zone.



**Table 3.2.070.B Additions to Historic Resources**

**1. Additions to an Existing Block-Form Historic Resource**

**2. Additions to an Existing House-Form Historic Resource**

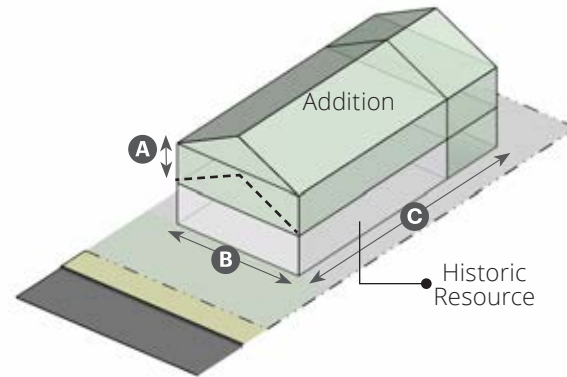
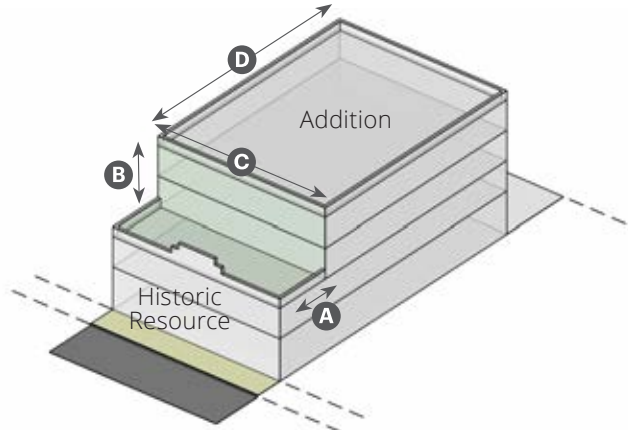

Intensification of an existing block-form historic resource with an addition on top

Intensification with an addition on top

Minimum 10' stepback from historic facade above height of existing historic resource, or a distance determined by a Qualified Architectural Historian and/or Design Review. **A**

Maximum 20' height addition above existing height of historic resource. For addition greater than 20', review required from a Qualified Architectural Historian and/or Design Review. **B**

Width **C** and Depth **D** of addition.<sup>1</sup>

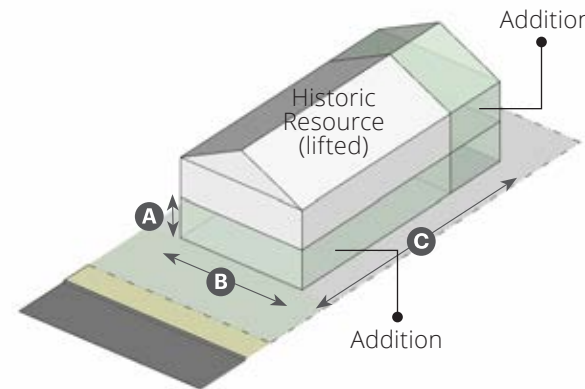

Intensification by lifting up resource and constructing below

Maximum 10' height addition above existing height of historic resource. For addition greater than 10', review required from a Qualified Architectural Historian and/or Design Review. **A**

Width **B** and Depth **C** of addition.<sup>1</sup>

<sup>1</sup> New building must be in compliance with all standards of the zone, and Secretary of the Interior's Standards for Rehabilitation (SISR) #9..

<sup>1</sup> New building must be in compliance with all standards of the zone, and Secretary of the Interior's Standards for Rehabilitation (SISR) #9.

# Division 3.3 Frontage Standards

## 3.3.010 Purpose

This Section sets forth standards applicable to all frontages. Frontages are the components of a building that provide the transition and interface between the public realm (street and sidewalk) and the private realm (yard or building):

- The names of the frontage types indicate their particular configuration or function and are not intended to limit uses within the associated building. For example, a porch may be used by non-residential uses including, but not limited to a restaurant or office as allowed by the zone.
- Each building shall include at least one frontage type along each street frontage or along a civic space.
- Each building may have multiple frontage types in compliance with the allowed types in DTFBC Sub-Section F (Frontages) of the zone.
- Frontage types not listed in DTFBC Sub-Section F (Frontages) of the zone are not allowed in that zone.
- Each frontage type shall be located in compliance with the facade zone per DTFBC Sub-Section C (Building Placement) of the zone.

Standards are stated for the front of a lot and are to be adjusted for side street facades in compliance with the setbacks of the zone.

## 3.3.020 Overview of Frontage Types



DTFBC Table 3.3.020.B (Frontage Types Overview) provides a summary of the allowed frontage types.

Each Frontage Type is allowed in more than one zone. For the purpose of clarity, the individual zones (e.g. T4N 30/40) are coordinated by their grouping (e.g. T4 Neighborhood). This Division uses these groupings to identify the allowed types in each zone and standards. See DTFBC Table 3.3.020.A (Zone Groupings).

**Table 3.3.020.A Zone Groupings**

	Zone	Key	Sub-Zone	Key
T4 Neighborhood	T4N 30/40	<b>T4N</b>	T4N 40/50 Open	<b>T4N-O</b>
	T4N 40/50			
T4 Main Street	T4MS 40/50	<b>T4MS</b>	T4MS 40/50 Open	<b>T4MS-O</b>
	T4MS 40/60		T4MS 40/60 Open	
	T4MS 50/70		T4MS 50/70 Open	
	T4MS 60/80			
T5 Neighborhood	T5N 40/60	<b>T5N</b>	T5N 40/60 Open	<b>T5N-O</b>
	T5N 50/70		T5N 50/70 Open	
T5 Main Street	T5MS 70/90	<b>T5MS</b>		

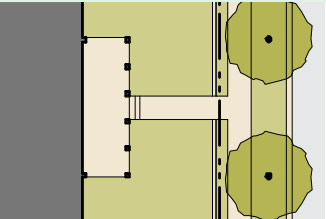
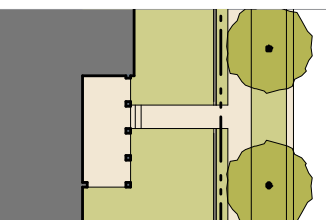
**Table 3.3.020.B Frontage Types Overview**

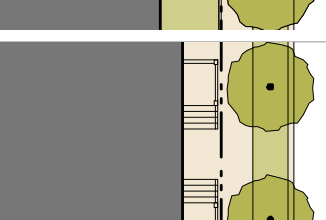
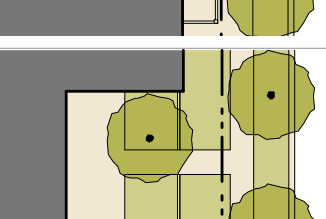
Frontage Type		Downtown Zones								
	<p><b>Porch Projecting 3.3.030.</b> The main facade of the building is set back from the front lot line with a covered structure encroaching into the front setback. The resulting setback area can be defined by a fence or hedge to spatially maintain the edge of the street. The Porch may be one or two stories, is open on three sides, with all habitable space located behind the building setback line.</p>	<table border="1"> <tr> <td>T4N</td> <td>T4N-O</td> </tr> <tr> <td>T4MS</td> <td>T4MS-O</td> </tr> <tr> <td>T5N</td> <td>T5N-O</td> </tr> <tr> <td>T5MS</td> <td></td> </tr> </table>	T4N	T4N-O	T4MS	T4MS-O	T5N	T5N-O	T5MS	
T4N	T4N-O									
T4MS	T4MS-O									
T5N	T5N-O									
T5MS										
	<p><b>Porch Engaged 3.3.040.</b> A portion of the main facade of the building is set back from the front lot line to create an area for a covered structure that projects from the facade that is set back. The Porch may project into the front setback. The resulting yard may be defined by a fence or hedge to spatially maintain the edge of the street. The Porch may be one or two stories and has two adjacent sides that are engaged to the building, while the other two sides are open.</p>	<table border="1"> <tr> <td>T4N</td> <td>T4N-O</td> </tr> <tr> <td>T4MS</td> <td>T4MS-O</td> </tr> <tr> <td>T5N</td> <td>T5N-O</td> </tr> <tr> <td>T5MS</td> <td></td> </tr> </table>	T4N	T4N-O	T4MS	T4MS-O	T5N	T5N-O	T5MS	
T4N	T4N-O									
T4MS	T4MS-O									
T5N	T5N-O									
T5MS										
	<p><b>Dooryard 3.3.050.</b> The main facade of the building is set back from the front lot line, which is defined by a low wall, hedge, or other allowed screening, creating a small private area between the sidewalk and the facade. Each Dooryard is separated from adjacent Dooryards. The Dooryard may be raised or at grade.</p>	<table border="1"> <tr> <td>T4N</td> <td>T4N-O</td> </tr> <tr> <td>T4MS</td> <td>T4MS-O</td> </tr> <tr> <td>T5N</td> <td>T5N-O</td> </tr> <tr> <td>T5MS</td> <td></td> </tr> </table>	T4N	T4N-O	T4MS	T4MS-O	T5N	T5N-O	T5MS	
T4N	T4N-O									
T4MS	T4MS-O									
T5N	T5N-O									
T5MS										
	<p><b>Stoop 3.3.060.</b> The main facade of the building is near the front lot line with steps to an elevated entry. The Stoop is elevated above the sidewalk to provide privacy along the sidewalk-facing rooms. Stairs or ramps from the Stoop may lead directly to the sidewalk or may be parallel to the sidewalk.</p>	<table border="1"> <tr> <td>T4N</td> <td>T4N-O</td> </tr> <tr> <td>T4MS</td> <td>T4MS-O</td> </tr> <tr> <td>T5N</td> <td>T5N-O</td> </tr> <tr> <td>T5MS</td> <td></td> </tr> </table>	T4N	T4N-O	T4MS	T4MS-O	T5N	T5N-O	T5MS	
T4N	T4N-O									
T4MS	T4MS-O									
T5N	T5N-O									
T5MS										
	<p><b>Forecourt 3.3.070.</b> The main facade of the building is at or near the front lot line and a portion is set back, extending the public realm into the lot for an entry court or shared garden space for housing, or as an additional shopping or restaurant seating area within retail and service areas.</p>	<table border="1"> <tr> <td>T4N</td> <td>T4N-O</td> </tr> <tr> <td>T4MS</td> <td>T4MS-O</td> </tr> <tr> <td>T5N</td> <td>T5N-O</td> </tr> <tr> <td>T5MS</td> <td></td> </tr> </table>	T4N	T4N-O	T4MS	T4MS-O	T5N	T5N-O	T5MS	
T4N	T4N-O									
T4MS	T4MS-O									
T5N	T5N-O									
T5MS										

**Key** T# Allowed T# Allowed in Open Sub-Zone T# Not Allowed

**Table 3.3.020.B Frontage Types Overview (Continued)**

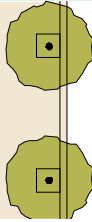
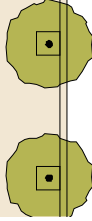
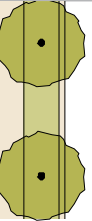
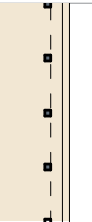
Frontage Type	Downtown Zones									
	<p><b>Maker Shopfront 3.3.080.</b> The main facade of the building is at or near the front lot line with an at-grade or elevated entrance from the sidewalk. This type is only allowed on side streets from the adjacent main street and is intended for industrial artisan businesses to show their activity to people passing by on the sidewalk, as well as for retail sales of products made on-site. The Maker Shopfront may include a decorative roll-down or sliding door, including glazing and an awning that overlaps the sidewalk.</p>	<table border="1"> <tr><td>T4N</td><td>T4N-O</td></tr> <tr><td>T4MS</td><td>T4MS-O</td></tr> <tr><td>T5N</td><td>T5N-O</td></tr> <tr><td>T5MS</td><td></td></tr> </table>	T4N	T4N-O	T4MS	T4MS-O	T5N	T5N-O	T5MS	
T4N	T4N-O									
T4MS	T4MS-O									
T5N	T5N-O									
T5MS										
	<p><b>Shopfront 3.3.090.</b> The main facade of the building is at or near the front lot line with at-grade entrance along the sidewalk. This type is intended for service, retail, or restaurant use and includes substantial glazing between the Shopfront base and the ground floor ceiling and may include an awning that overlaps the sidewalk.</p>	<table border="1"> <tr><td>T4N</td><td>T4N-O</td></tr> <tr><td>T4MS</td><td>T4MS-O</td></tr> <tr><td>T5N</td><td>T5N-O</td></tr> <tr><td>T5MS</td><td></td></tr> </table>	T4N	T4N-O	T4MS	T4MS-O	T5N	T5N-O	T5MS	
T4N	T4N-O									
T4MS	T4MS-O									
T5N	T5N-O									
T5MS										
	<p><b>Terrace 3.3.100.</b> The main facade is at or near the front lot line with steps leading to an elevated area providing public circulation along the facade. This type is used to provide outdoor areas along the sidewalk for housing or to accommodate an existing or intended grade change for retail, service or office uses.</p>	<table border="1"> <tr><td>T4N</td><td>T4N-O</td></tr> <tr><td>T4MS</td><td>T4MS-O</td></tr> <tr><td>T5N</td><td>T5N-O</td></tr> <tr><td>T5MS</td><td></td></tr> </table>	T4N	T4N-O	T4MS	T4MS-O	T5N	T5N-O	T5MS	
T4N	T4N-O									
T4MS	T4MS-O									
T5N	T5N-O									
T5MS										
	<p><b>Gallery 3.3.110.</b> The main facade of the building is setback from the front lot line and an at-grade covered structure, typically articulated with colonnade or arches, covers an area not in the right-of-way. This type may be one or two stories. When used in non-residential settings, the Shopfront Type is included; when used in residential settings, Stoops, Dooryards, and Forecourts are included.</p>	<table border="1"> <tr><td>T4N</td><td>T4N-O</td></tr> <tr><td>T4MS</td><td>T4MS-O</td></tr> <tr><td>T5N</td><td>T5N-O</td></tr> <tr><td>T5MS</td><td></td></tr> </table>	T4N	T4N-O	T4MS	T4MS-O	T5N	T5N-O	T5MS	
T4N	T4N-O									
T4MS	T4MS-O									
T5N	T5N-O									
T5MS										

**Key** T# Allowed T# Allowed in Open Sub-Zone T# Not Allowed

### 3.3.030 Porch Projecting



Example is a Projecting Porch.

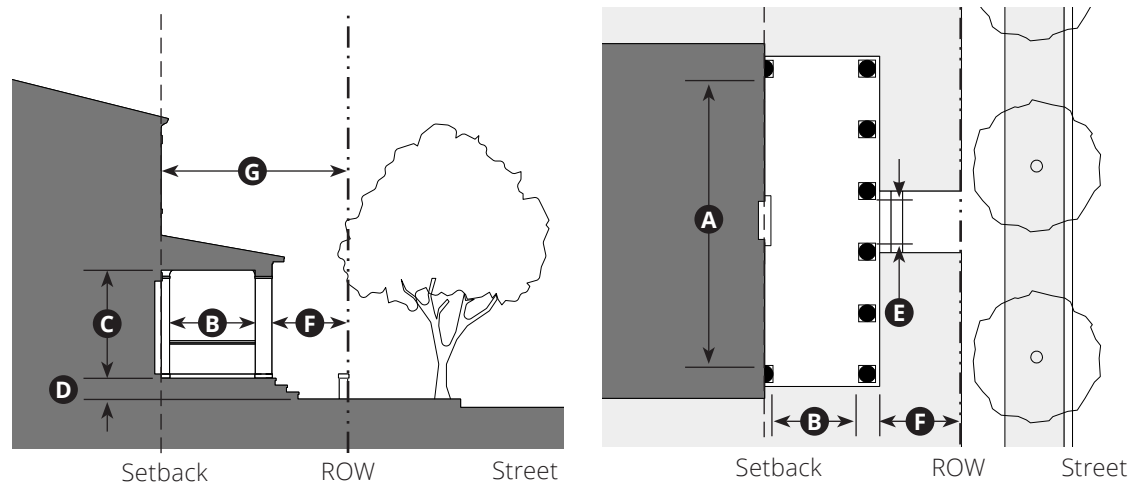

**Key**  
 - - - - ROW/Lot Line                      - - - - Setback Line

#### A. Description

The main facade of the building is set back from the front lot line with a covered structure encroaching into the front setback. The resulting setback area can be defined by a fence or hedge to spatially maintain the edge of the street. The Porch may be one or two stories, is open on three sides, with all habitable space located behind the building setback line.

#### B. Size

Width, Clear	10' min.	<b>A</b>
Depth, Clear	6' min.	<b>B</b>
Height, Clear	8' min.	<b>C</b>
Overall Height	1 floor max. above ground floor in T4N Zones; 2 floors max. above ground floor in T5N Zones	
Finish Level above Sidewalk	12" min.	<b>D</b>
Pedestrian Access	3' wide min.	<b>E</b>
Distance between Porch and Sidewalk	6' min.	<b>F</b>
Depth	15' min.	<b>G</b>

#### C. Miscellaneous

Porch shall be open on three sides and have a roof. Clear glass may be installed between the porch columns if the minimum size of individual panes is 24".

Porches are an allowable encroaching element into setbacks.

When ramps are included, Design Review is required.

<b>T4N</b>	<b>T4N-O</b>	<b>T4MS</b>	<b>T4MS-O</b>	<b>T5N</b>	<b>T5N-O</b>
<b>T5MS</b>					

General Note: Photos on this page are illustrative, not regulatory.

**Key** **T#** Allowed    **T#** Allowed in Open Sub-Zone    **T#** Not Allowed

### 3.3.040 Porch Engaged



Example of a 2-story Engaged Porch.

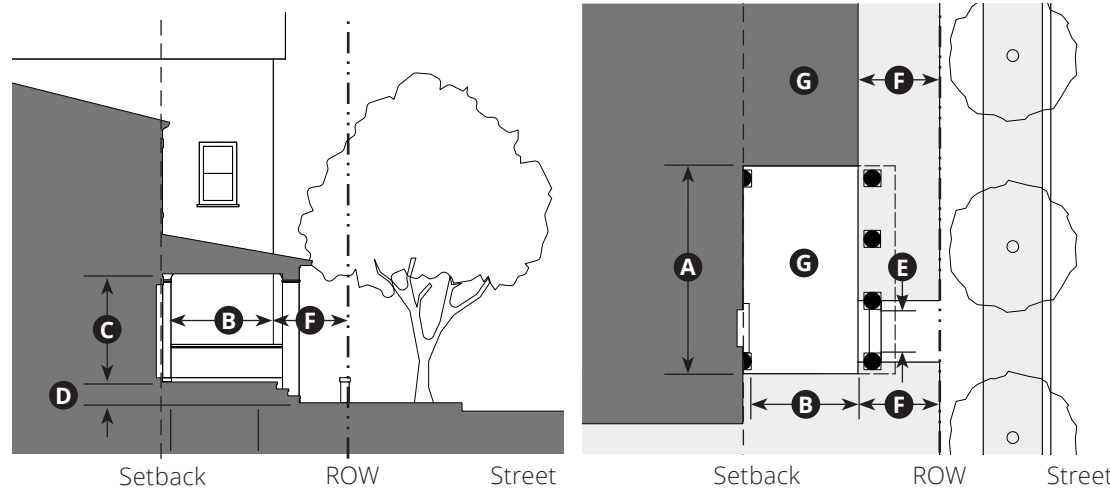

**Key**  
 - - - - ROW/ Lot Line                      - - - - Setback Line

#### A. Description

A portion of the main facade of the building is set back from the front lot line to create an area for a covered structure that projects from the facade that is set back. The Porch may project into the front setback. The resulting yard may be defined by a fence or hedge to spatially maintain the edge of the street. The Porch may be one or two stories and has two adjacent sides that are engaged to the building, while the other two sides are open.

#### B. Size

Width, Clear	8' min.	<b>A</b>
Depth, Clear	6' min.	<b>B</b>
Height, Clear	8' min.	<b>C</b>
Stories	3 Stories max.	
Finish Level above Sidewalk	12" min.	<b>D</b>
Pedestrian Access	3' wide min.	<b>E</b>
Distance between projected Building Facade, Porch and Sidewalk	6' min.	<b>F</b>

Up to 20% of the building facade and associated porch may project beyond the setback line into the required setback. **G**

#### C. Miscellaneous

Porch shall be open on two sides and have a roof. Clear glass maybe installed between the porch columns if the minimum size of individual panes is 24".

When ramps are included, Design Review is required.

<b>T4N</b>	<b>T4N-O</b>	<b>T4MS</b>	<b>T4MS-O</b>	<b>T5N</b>	<b>T5N-O</b>
<b>T5MS</b>					

General Note: Photos on this page are illustrative, not regulatory.

**Key** **T#** Allowed    **T#** Allowed in Open Sub-Zone    **T#** Not Allowed

### 3.3.050 Dooryard



Example of a residential Dooryard.

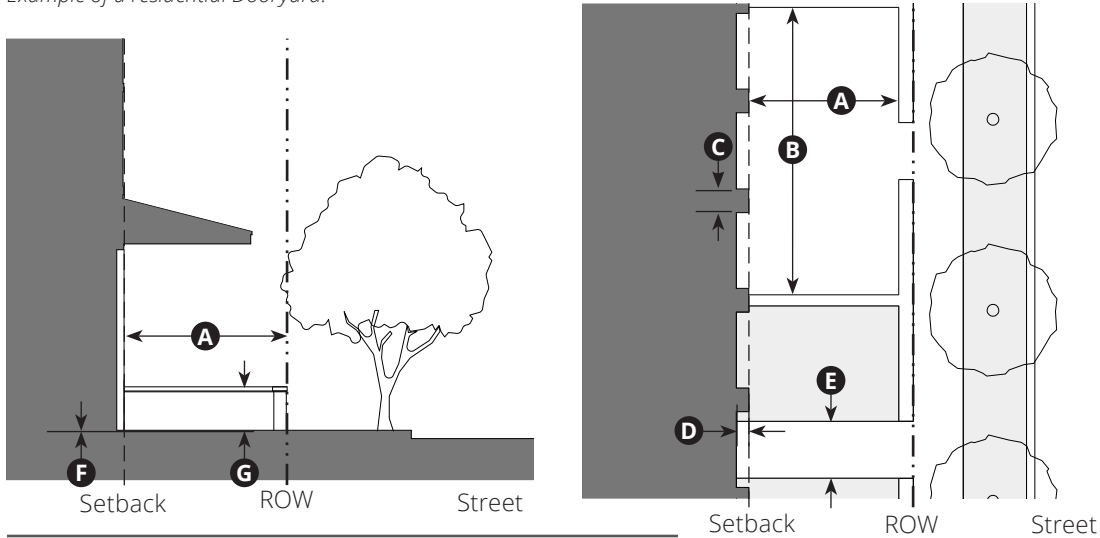

**Key**  
 ---- ROW/ Lot Line      - - - - - Setback Line

#### A. Description

The main facade of the building is set back from the front lot line, which is defined by a low wall, hedge, or other allowed screening, creating a small private area between the sidewalk and the facade. Each Dooryard is separated from adjacent Dooryards. The Dooryard may be raised or at grade.

#### B. Size

Depth, Clear	6' min.	<b>A</b>
Length	10' min.	<b>B</b>
Distance between Glazing	4' max.	<b>C</b>
Depth of Recessed Entries	3' max.	<b>D</b>
Pedestrian Access	3' wide min.	<b>E</b>
Finish Level above Sidewalk	0" min., 12" max.	<b>F</b>
Height of Dooryard Fence/ Wall above Finish Level	36" max.	<b>G</b>

#### C. Miscellaneous

Each Dooryard shall provide access to only one ground floor entry.

For live/ work, retail, service, and restaurant uses, the Shopfront Frontage Type is to also be applied.

<b>T4N</b>	<b>T4N-O</b>	<b>T4MS</b>	<b>T4MS-O</b>	<b>T5N</b>	<b>T5N-O</b>
<b>T5MS</b>					

*General Note: Photos on this page are illustrative, not regulatory.*

**Key** **T#** Allowed    **T#** Allowed in Open Sub-Zone    **T#** Not Allowed



### 3.3.060 Stoop



Example of Stoop.

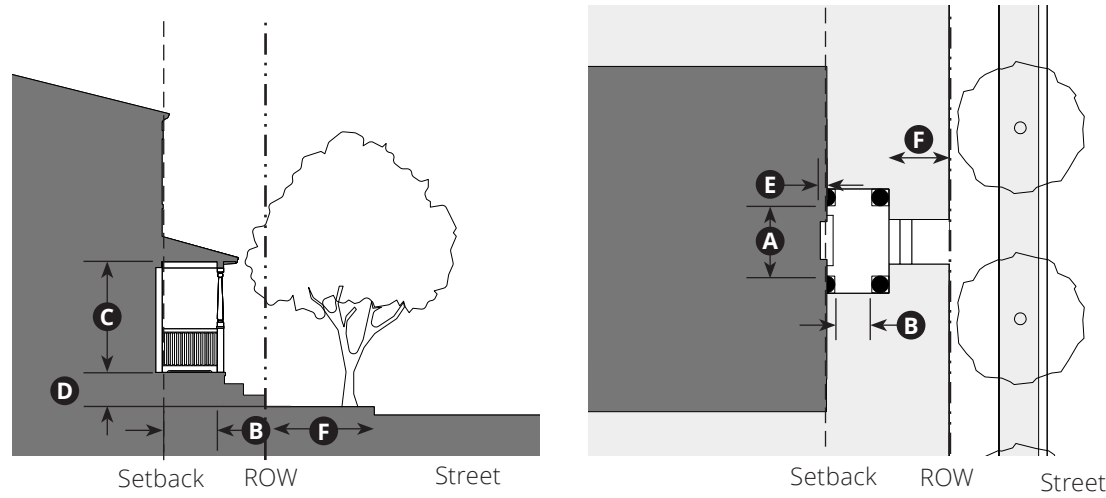

**Key**  
 - - - - ROW/ Lot Line                      - - - - - Setback Line

#### A. Description

The main facade of the building is near the front lot line with steps to an elevated entry. The Stoop is elevated above the sidewalk to provide privacy along the sidewalk-facing rooms. Stairs or ramps from the Stoop may lead directly to the sidewalk or may be parallel to the sidewalk.

#### B. Size

Width, Clear	5' min.	<b>A</b>
Depth, Clear	3' min.	<b>B</b>
Height, Clear	8' min.	<b>C</b>
Finish Level above Sidewalk	12" min.	<b>D</b>
Depth of Recessed Entry	5' max.	<b>E</b>
Distance between Stoop and Sidewalk	3' min.	<b>F</b>

#### C. Miscellaneous

Stairs may be perpendicular or parallel to the building facade.

Ramps shall be parallel to facade or along the side of the building.

When ramps are included, Design Review is required.

Entry doors are covered or recessed to provide shelter from the elements.

Gates are not allowed.

All doors shall face the street.

<b>T4N</b>	<b>T4N-O</b>	<b>T4MS</b>	<b>T4MS-O</b>	<b>T5N</b>	<b>T5N-O</b>
<b>T5MS</b>					

*General Note: Photos on this page are illustrative, not regulatory.*

**Key** **T#** Allowed    **T#** Allowed in Open Sub-Zone    **T#** Not Allowed

### 3.3.070 Forecourt



Example of a Forecourt.

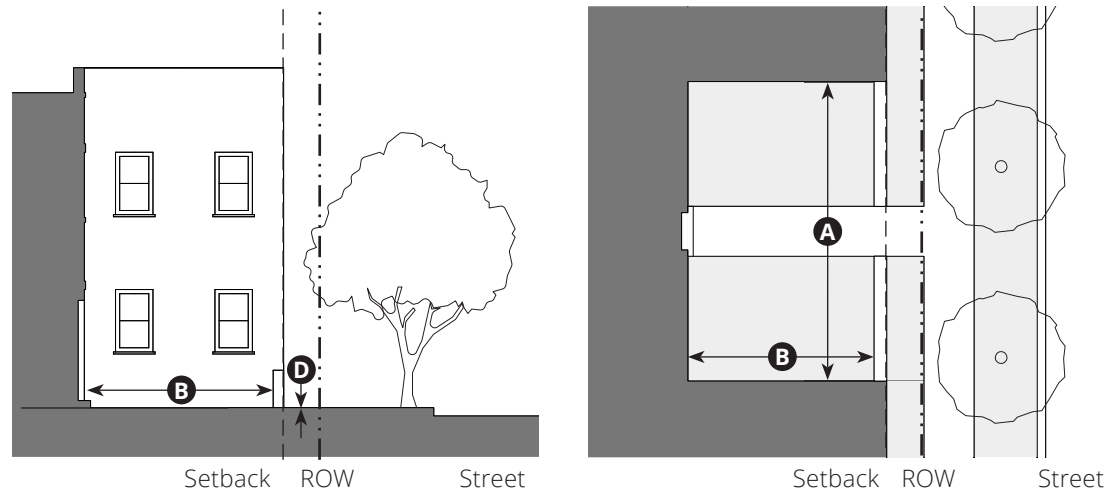

**Key**  
 ---- ROW/ Lot Line                      - - - - - Setback Line

#### A. Description

The main facade of the building is at or near the front lot line and a portion is set back, extending the public realm into the lot for an entry court or shared garden space for housing, or as an additional shopping or restaurant seating area within retail and service areas.

#### B. Size

Width, Clear	15' min.	<b>A</b>
Depth, Clear	15' min.	<b>B</b>
Ratio, Height to Width	2:1 max.	<b>C</b>
Height from Sidewalk	12" max. above Sidewalk	<b>D</b>

#### C. Miscellaneous

May be utilized to group several entries at a common elevation in compliance with accessibility standards.

T4N	T4N-O	T4MS	T4MS-O	T5N	T5N-O
T5MS					

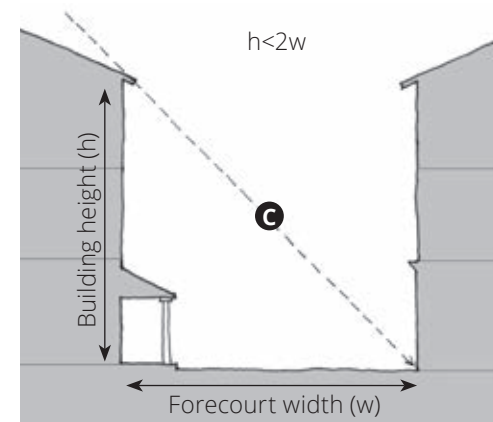

General Note: Photos on this page are illustrative, not regulatory.

**Key** **T#** Allowed   **T#** Allowed in Open Sub-Zone   **T#** Not Allowed

### 3.3.080 Maker Shopfront



Example of a Maker Shopfront.

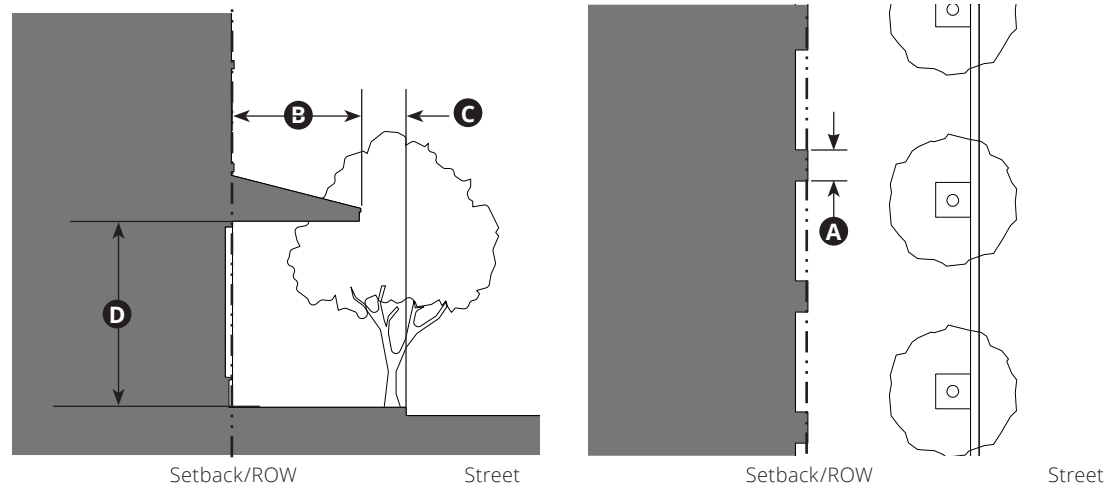

**Key**  
 - - - - ROW/ Lot Line                      - - - - Setback Line

#### A. Description

The main facade of the building is at or near the front lot line with an at-grade or elevated entrance from the sidewalk. This type is only allowed on side streets from the adjacent main street and is intended for industrial artisan businesses to show their activity to people passing by on the sidewalk, as well as for retail sales of products made on-site. The Maker Shopfront may include a decorative roll-down or sliding door, including glazing and an awning that overlaps the sidewalk.

#### B. Size

Distance between Glazing	10' max.	<b>A</b>
Ground Floor Glazing between Sidewalk and Finished Ceiling Height	20% min.	

#### C. Awning

Depth	5' min.	<b>B</b>
Setback from Curb	2' min.	<b>C</b>
Height, Clear	8' min.	<b>D</b>

#### D. Miscellaneous

Rounded and hooped awning are not allowed.  
 Decorative accordion-style doors/ windows or other operable windows that allow the space to open to the street require Director approval.

T4N	T4N-O	T4MS	T4MS-O	T5N	T5N-O
T5MS					

General Note: Photos on this page are illustrative, not regulatory.

**Key** **T#** Allowed    **T#** Allowed in Open Sub-Zone    **T#** Not Allowed

### 3.3.090 Shopfront



Example of Shopfronts.

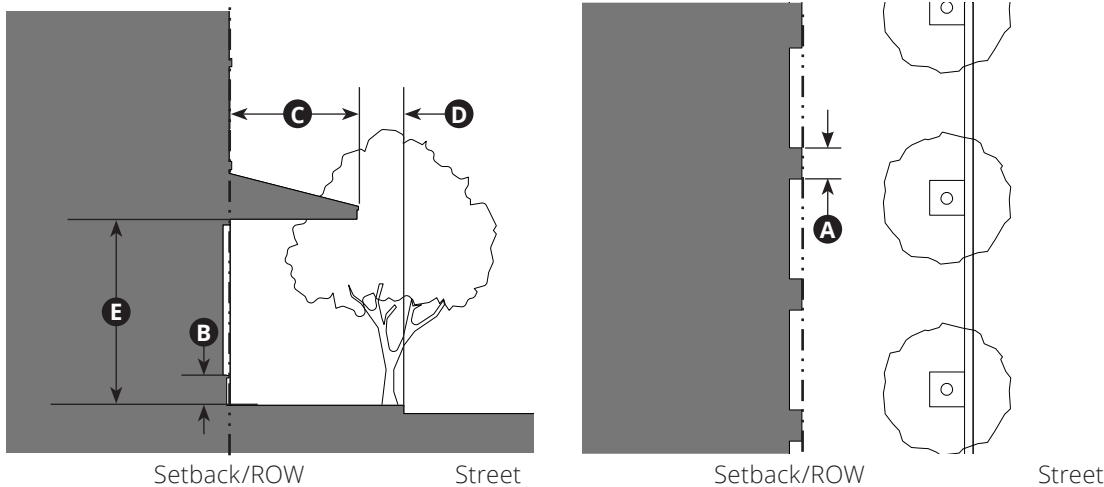

**Key**  
 - - - - ROW/ Lot Line                      - - - - Setback Line

#### A. Description

The main facade of the building is at or near the front lot line with at-grade entrance along the sidewalk. This type is intended for service, retail, or restaurant use and includes substantial glazing between the Shopfront base and the ground floor ceiling and may include an awning that overlaps the sidewalk.

#### B. Size

Distance between Glazing	3' max.	<b>A</b>
Ground Floor Glazing between Sidewalk and Finished Ceiling Height	75% min.	
Depth of Recessed Entries	5' max.	
Shopfront Base	12" min.; 30" max.	<b>B</b>

#### C. Awning

Depth	5' min.	<b>C</b>
Setback from Curb	2' min.	<b>D</b>
Height, Clear	8' min.	<b>E</b>

#### D. Miscellaneous

Mirrored or other reflective finishes, opaque, or other finishes that diminish views into views and out of the ground floor are not allowed.

Residential types of windows are not allowed.

Rounded and hooped awning are not allowed.

Decorative accordion-style doors/ windows or other operable windows that allow the space to open to the street require Director approval.

T4N	T4N-O	<b>T4MS</b>	T4MS-O	T5N	T5N-O
<b>T5MS</b>					

General Note: Photos on this page are illustrative, not regulatory.

**Key** **T#** Allowed    **T#** Allowed in Open Sub-Zone    **T#** Not Allowed

### 3.3.100 Terrace



Example of a Terrace with low-wall seating.

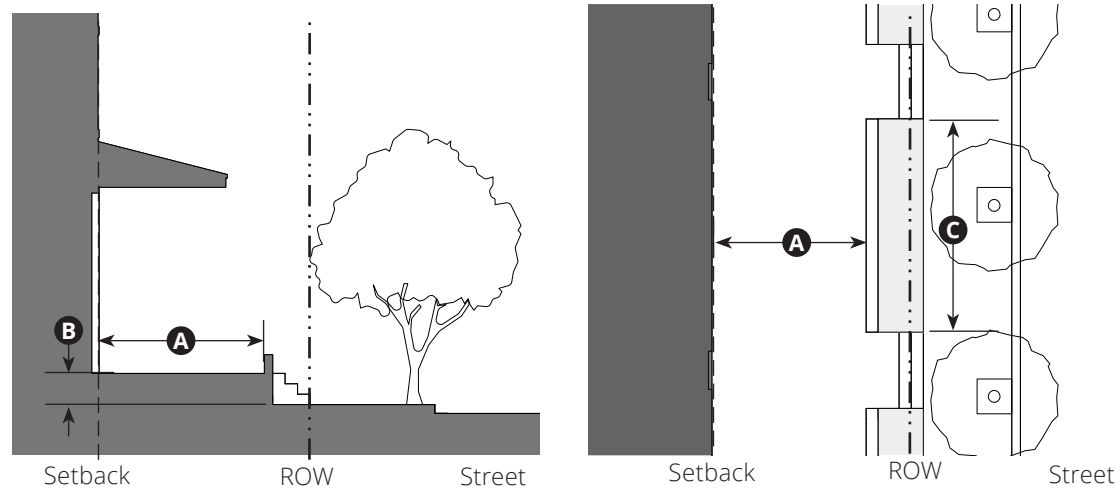

**Key**  
 - - - - ROW/ Lot Line                      - - - - Setback Line

#### A. Description

The main facade is at or near the front lot line with steps leading to an elevated area providing public circulation along the facade. This type is used to provide outdoor areas along the sidewalk for housing or to accommodate an existing or intended grade change for retail, service or office uses.

#### B. Size

Depth of Terrace	8' min. Residential	<b>A</b>
	12' min. Non-residential	
Finish Level above Sidewalk	36" max.	<b>B</b>
Distance between Stairs	25' max.	<b>C</b>

#### C. Miscellaneous

Where the zone requires the Shopfront Type, these standards are to be used with those for the Shopfront Frontage Type.

Where the frontage type requires the ground floor to be flush with the sidewalk, the terrace shall be considered to be the sidewalk.

Low walls used as seating are allowed.

May be utilized to group several entries at a common elevation in compliance with the zones' ground floor finish level standards.

T4N	T4N-O	T4MS	T4MS-O	T5N	T5N-O
T5MS					

General Note: Photos on this page are illustrative, not regulatory.

**Key** **T#** Allowed    **T#** Allowed in Open Sub-Zone    **T#** Not Allowed

### 3.3.110 Gallery



Example of a Gallery.

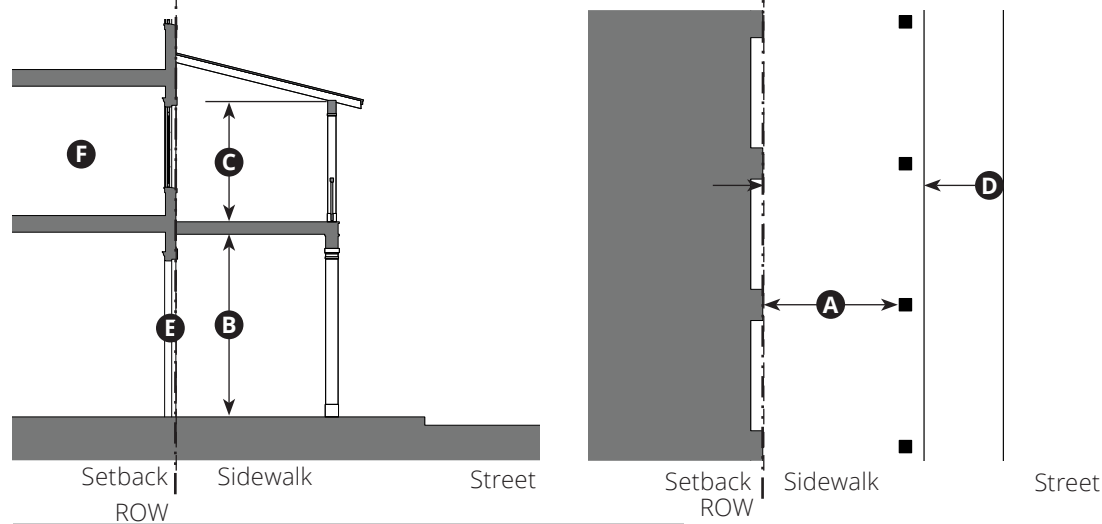

**Key**  
 - - - - ROW/Lot Line                      - - - - Setback Line

#### A. Description

The main facade of the building is setback at or near the front lot line and an at-grade covered structure, typically articulated with colonnade or arches, covers an area in the right-of-way. This type may be one or multiple stories. When used in non-residential settings, the Shopfront Type is included; when used in residential settings, Stoops, Dooryards, and Forecourts are included.

#### B. Size

Depth, Clear	8' min.	<b>A</b>
Ground Floor Height, Clear	12' min.	<b>B</b>
Roof Deck Height, Clear	9' min.	<b>C</b>
Setback from Curb	18" min.	<b>D</b>

#### C. Miscellaneous

Galleries shall also follow the standards for the Shopfront Frontage Type.	<b>E</b>
Habitable space	<b>F</b>

Roof Deck above Gallery may be covered.  
 Galleries shall have a consistent depth.  
 Galleries are allowed to project over the sidewalk in the public right-of-way.

T4N	T4N-O	<b>T4MS</b>	T4MS-O	T5N	T5N-O
<b>T5MS</b>					

General Note: Photos on this page are illustrative, not regulatory.

**Key** **T#** Allowed    **T#** Allowed in Open Sub-Zone    **T#** Not Allowed

*This page intentionally left blank*





# Definitions

ARTICLE

# 4



# Division 4.1 Definitions

## 4.1.010 Definitions

This Section provides definitions for specialized terms and phrases used in this Article. All other applicable definitions in SRMC Chapter 14.03 (Definitions) of Title 14 (Zoning) apply.

Additional information regarding the methods and measurements for Facade Zone and Highest Top Plate is provided in DTFBC Section 4.1.030 (Measurement Methods).

### A Definitions

**Architectural Features.** Exterior building elements intended to provide ornamentation to the building, including, but not limited to: eaves, cornices, bay windows, window and door surrounds, light fixtures, canopies, and balconies.

### B Definitions

**Bay Window.** A window that projects from the building facade that begins on the ground floor and can extend to upper floors, or begin on an upper floor.

**Block Face.** The aggregate of all building facades on one side of a block. The block face provides the context for establishing architectural harmony.

**Block-Form, Building.** A building that is individually as large as a block or individual buildings collectively

arranged along a street to form a continuous facade as long as most or all of a block.

**Block Length.** The horizontal distance measured from one end of the block to the other end along the same street.

**Block Perimeter.** The aggregate of all sides of a block measured along the adjacent streets.

**Buildable Area.** The horizontal area in which a building can be constructed.

**Building Entrance.** A point of pedestrian ingress and egress to the front of a building along the sidewalk of the street immediately adjacent to the building.

**Building Envelope.** The three-dimensional shape resulting from applying all required building setbacks, maximum building height, upper floor stepbacks, and facade/ massing articulation requirements.

**Building Depth.** The horizontal distance from one end of the building to the other end measured perpendicular to the front lot line, including wings.

**Building Facade.** The exterior wall of a building adjacent to a street, or civic space, the front or side along a private street.

**Building Form.** The overall shape and dimensions of a building.

**Building Frontage.** The ground floor facade(s) parallel to and along each adjoining street and/or open space.

**Building Width.** The horizontal distance from one end of the building to the other end measured parallel to the front lot line, including wings.

### C Definitions

**Carshare Parking Space.** A parking space required to be dedicated for current or future use by a carshare service through a deed restriction, condition of approval, or license agreement. Such deed restriction, condition of approval, or license agreement shall grant priority use to any carshare service that can make use of the space, although such spaces may be occupied by other vehicles so long as no carshare organization can make use of the dedicated carshare space(s).

**Carshare Service.** A service that provides a network of motor vehicles available to rent by members by reservation on an hourly basis, or in smaller intervals.

**Ceiling Height, Ground Floor.** The height from finished floor to finished ceiling of primary rooms on the ground floor, not including secondary rooms such as bathrooms, closets, utility rooms, and storage spaces.

**Chamfered Corner.** An external wall of a building joining two perpendicular exterior walls, typically at a symmetrical, 45 degree angle creating a beveled edge to the building rather than a 90 degree corner.

**Civic.** A term defining not-for-profit organizations that are dedicated to arts, culture, education, religious activities, recreation, government, transit, and public parking facilities.

**Civic Building.** A structure operated by governmental or not-for-profit organizations and limited to civic and related uses.

**Common Space (Common Area).** A portion of a development held in common and/or single ownership and not reserved for the exclusive use or benefit of an individual tenant or owner and is available for use by all persons who reside or work in the building or on the design site.

**Community Garden (Use Type).** Land used by multiple users for the cultivation, of fruits, vegetables, plants, flowers, or herbs.

**Corner Element.** A physical distinction in a building at the corner of two streets or a street and civic space. The physical distinction is from the ground floor through a majority of the facade or through the top of the facade.

**Corner Entry.** A pedestrian entrance located on the corner of a building or lot.

**Co-working Space.** A facilitated environment which may include shared facilities but not limited to conference rooms, reception services, phones, and other business amenities. Work spaces are used by a recognized membership who share the site in order to interact and collaborate with each other as part of a community and to reduce duplicated costs by sharing facilities. The uses shall have externally observable attributes similar to uses allowed in the zone in which that they are located. Equipment is limited to those which do not generate noise or pollutants in excess of what is customary within a typical office environment. Such space located in a research & development building may use equipment consistent with research & development uses. Co-working space may be interchangeably referred to as "incubator space."

**Courtyard.** An unroofed area that is completely or partially enclosed by walls or buildings on at least two sides and often shared by multiple residential units or non-residential suites.

## D Definitions

**Depth, Ground-Floor Space.** The distance from the street-facing facade to the rear interior wall of the ground-floor space available to allowed uses.

**Depth-to-Height Ratio.** The relationship of the depth of a space measured perpendicular to a building divided by the height of the adjacent wall(s).

**Disposition, Formal.** Composed in a formal arrangement, in a regular, classical, and typically symmetrical manner.

**Disposition, Informal.** Composed in an informal character with a mix of formal and natural characteristics.

**Distance Between Entries.** The horizontal distance measured parallel to the facade between entrances to a building or buildings.

**Dooryard.** See DTFBC Section 3.3.050 (Dooryard).

**Double-Loaded, Building.** A building containing dwellings and/or commercial suites with common hallways for access to the dwellings and/or suites.

**Dormer.** A window set vertically in a structure projecting through a sloping roof.

## E Definitions

**Elevated Ground Floor.** A ground floor located above the grade plane of the adjacent sidewalk.

**Encroachment.** Any architectural feature, structure, or structural element, that breaks the plane of a vertical or horizontal regulatory limit extending into a setback, or above a height limit.

**Entry.** An opening, such as a door, passage, or gate, that allows access to a building or lot.

**Entry, Primary.** The opening that allows access to a building directly from the sidewalk along the front facade.

**Entry, Service.** An entrance located toward or at the rear of the building intended for the delivery of goods and removal of refuse.

## F Definitions

**Facade.** See Building Facade.

**Facade Zone.** The area between the minimum and maximum setback lines along the front of a lot and along the side street of a corner lot. This area is where a minimum horizontal length of the building facade is required to be placed. The maximum horizontal length of the building facade is limited by the required side setbacks. The horizontal length of the facade not required to be in the facade zone may be placed anywhere within the allowed setbacks of the zone.

**Finish Level, Ground Floor.** The height difference between the finished floor on the ground floor and the adjacent sidewalk. In the case of a terrace frontage, the floor finish level is the height of the walk above the adjacent street. Regulations for ground floor finish level for ground floor residential uses do not apply to ground floor lobbies and common areas in buildings.

**Flex Space.** A room or group of internally connected rooms designed to accommodate future commercial uses, while initially accommodating less intense short-term uses, such as residential or live/work, until the commercial demand has been established.

**Floorplate.** The square footage area measurement of either the gross or the rentable floor area of a floor in a building.

**Floorplate, Non-residential.** The square footage area measurement of a floorplate dedicated to non-residential uses.

**Floorplate, Residential.** The square footage area measurement of a floorplate dedicated to residential uses.

**Footprint, Building.** The outline of the area of ground covered by the foundations of a building or structure.

**Freestanding Wall.** A wall that is separate from a building and supported by independent means.

**Front.** See Lot Line, Front.

**Frontage, Private.** The area between the building facade and the back of the sidewalk abutting a street or civic space.

**Frontage, Public.** The area between the on-street parking and the back of the sidewalk.

**Frontage Type.** Physical element(s) configured to connect the building facade to the back of the sidewalk abutting a street or civic open space.

### G Definitions

**Gable.** A vertical wall in the shape of a triangle formed between the cornice or eave and the ridge of the roof.

**Glazing.** Openings in a building in which glass is installed.

**Gross Floor Area.** The total floor area inside the building envelope, including the external walls, but not including the roof.

### H Definitions

**Height, Number of Stories.** The number of stories in a structure allowed above adjacent finished grade. See "Story."

**Height, Overall.** The vertical distance between adjacent finished grade and the highest part of the structure directly above.

**Highest Top Plate.** The vertical distance between adjacent finished grade and the highest top plate/eave of the building.

**Historic Resource.** A building or collection of buildings that was identified in the 2019/2020 San Rafael Downtown historic survey as being previously landmarked or potentially eligible for landmarking as an individual resource, a contributing resource, or a historic district.

**House-Form, Building.** A building that is the size of a small-to-large house and detached from other buildings, typically ranging from 20 feet to as large as 80 feet overall, including wings.

### I Definitions

**Improvement.** The product of any modification to a site, structure or building.

### J Definitions

No specialized terms beginning with the letter J are defined at this time.

### K Definitions

No specialized terms beginning with the letter K are defined at this time.

### L Definitions

**Landing.** A level area at the top or bottom of a staircase or between one flight of stairs and another.

**Lot Line, Front.** The perimeter boundary of a lot along the narrow side of the lot as compared to the lot's depth. The front is typically narrower than the side and provides the physical location for the address of the lot. Exceptions to this approach are historic lots that can have front lot lines that exceed the length of the side lot lines.

### M Definitions

**Main Body.** The primary massing of the main building on a lot.

**Main Building.** The building that contains the principal use of the lot on which it is situated.

**Main Facade.** The front facade of a building.

**Major.** Having a greater size, scope, effect, characteristic or quality relative to the other corresponding sizes, scopes, effects, characteristics or qualities; or being the greater of two or more.

**Massing.** The overall shape or arrangement of the bulk or volume of a building.

**Minor.** Having a lesser size, scope, effect, characteristic or quality relative to the average size, scope, effect, characteristic or qualities; or being the lesser of two or more.

### N Definitions

No specialized terms beginning with the letter N are defined at this time.

### O Definitions

**Office Amenity Space.** Non-employee, non-traffic-generating uses that are not easily convertible to employee-generating uses such as exterior covered walkways, lobby atrium, large cafeteria and employee lounge areas, employee fitness areas, and laboratories.

**Oriel Window (Syn Upper Floor Bay Window).** A window that projects from the building facade and may extend for multiple stories.

**Overdoors.** A canopy or other small covering above an exterior door.

**Overhead Doors.** Doors constructed in horizontally hinged sections that are equipped with hardware that rolls the sections into an overhead position, clear of the opening.

### P Definitions

**Parapet.** A wall along the edge of a roof or the portion of a wall that extends above the roof line.

**Parking Driveway Width.** The horizontal measurement of an access driveway to a parking area, measured perpendicular to the direction of travel.

**Pedestrian-oriented Business.** Business located in a context that encourages people to walk instead of drive by allowing customers to park once and complete multiple transactions and visits on foot.

**Planting Strip.** A landscaped or grassy area located between the street and the adjacent sidewalk.

**Podium.** A continuous base or pedestal under a building often occupied by parking.

**Podium Top.** A flat, elevated and open area above a podium that can be used as common area or simply as the base for upper floors.

**Porch Engaged.** See DTFBC Section 3.3.040 (Porch Engaged).

**Porch Projecting.** See DTFBC Section 3.3.030 (Porch Projecting).

**Production, Artisanal.** Food and/or products made by hand.

**Public Use.** A use undertaken by a political subdivision, its agents or assigns.

## Q Definitions

No specialized terms beginning with the letter Y are defined at this time.

## R Definitions

**Rear.** Opposite of front.

**Rear Loaded (Rear Access).** Lots that provide vehicular access from the rear of the lot.

**Recessed Entry.** A building entrance that is recessed from the facade of the building.

**Regulating Plan.** The map that identifies the zoning and standards for each lot in the Plan boundaries.

## S Definitions

**Semi-Public Use.** A use owned or operated by a non-profit organization, private institution or foundation.

**Service Entries.** Building access for service activities.

**Setback, Building.** The required clear distance between a lot line and the building.

**Setback, Parking.** The required clear distance between a lot line and parking.

**Shared Parking.** Any parking spaces assigned to more than one user, where different persons utilizing the spaces are unlikely to need the spaces at the same time of day.

**Shopfront Base.** A very low wall, that does not include glass, between the display window(s) of a shopfront and the adjacent sidewalk.

**Sidewalk.** A paved area along a street intended exclusively for pedestrian use and often installed between the street and a lot.

**Single-Loaded, Building.** A building containing dwellings and/or commercial suites without common hallways for access to the dwellings and/or suites.

**Stealth Design.** The effect of integrating an element such as a cellular antenna into a building that results in the element being unobtrusive and not easily perceived from adjacent public sidewalks and civic space.

**Stoop.** See DTFBC Section 3.3.060 (Stoop).

**Story.** The portion of a building included between the surface of any floor and the surface of the next floor above it, or if there is no floor above, the space between the floor and the ceiling above. If the finished floor level directly above a basement or cellar is more than six feet above grade for more than 50 percent of the total perimeter, such basement or cellar shall be considered a story.

- **Story, Ground.** The lowest story or the ground story of any building, the floor of which is not more than 12 inches below the average contact ground level at the exterior walls of the building.
- **Story, Mezzanine.** A story which covers one-third or less of the area of the story directly underneath it. A mezzanine story shall be deemed a full story when it covers more than one-third of the area of the story directly underneath said mezzanine story.

**Street, Front.** Street located along the front lot line.

**Street, Side.** Street located along a lot line that is not the front or the rear lot line.

**Street Frontage, Principal.** The property line of a lot parallel to and along the public right-of-way which it borders and which is identified by an officially assigned street address.

**Street Tree.** A tree of any species or size planted in open spaces, parkways, sidewalk areas, easements, and streets.

### T Definitions

**Tandem Parking.** A parking space deep enough to allow two cars to park, one behind the other.

**Transit Stop.** A location where buses stop to load and unload passengers. A transit stop sometimes includes a shelter or a dedicated platform along the sidewalk.

### U Definitions

**Understory.** The smaller trees and shrubs below the canopy of large trees.

**Upper Floor.** A floor in a building containing habitable space that is located above the ground floor.

**Urban Agriculture (Crop Production).** Areas in some form of small-scale cultivation such as row crops, orchards, or greenhouses that support nearby or on-site food businesses, including cafés and restaurants.

### V Definitions

No specialized terms beginning with the letter V are defined at this time.

### W Definitions

**Walkability.** The condition when an area pedestrian-oriented in nature, where bicycling and walking are viable daily options because services, retail and food uses are within a short walking distance of most dwellings.

**Wall Plane.** A vertical surface defined by the facade(s) of a building(s).

**Width-to-Height Ratio.** The ratio of the horizontal size of a space measured perpendicularly to the vertical height of a building.

**Wing.** A structure physically attached to, and smaller in footprint and height to, the Main Body of a building.

### X Definitions

No specialized terms beginning with the letter X are defined at this time.

### Y Definitions

No specialized terms beginning with the letter Y are defined at this time.

### Z Definitions

No specialized terms beginning with the letter Z are defined at this time.



### 4.1.020 Use Types

This Section provides definitions for specialized terms and phrases used in this Article. All other applicable definitions in SRMC Chapter 14.03 (Definitions) of Title 14 (Zoning) apply.

#### A Use Definitions

**Artisan/ Craft Production.** A facility accommodating manufacturing processes involving less intense levels of fabrication and/or production such as the assembly, fabrication, and conversion of already processed raw materials into products, where the operational characteristics of the manufacturing processes and the materials used are unlikely to cause significant impacts on surrounding land uses or the community. Examples of light manufacturing/assembly uses include:

- **Artisan/Craft Product Manufacturing.** An establishment that manufactures and/or assembles small products primarily by hand, including jewelry, pottery and other ceramics, as well as small glass and metal art and craft products, where any retail sales are incidental to the manufacturing activity.
- **Clothing and Fabric Product Manufacturing.** An establishment that assembles clothing, draperies, and/or other products by cutting and sewing purchased textile fabrics, and related materials including leather, rubberized fabrics, plastics and furs. Does not include custom tailors and dressmakers not operating as a factory and not located on the site of a clothing store - see DTFBC 4.1.020 Use Types "Personal Service". Does not include the production of textile fabrics and related materials.
- **Handcraft Industries, Small-Scale Manufacturing.** Establishments manufacturing and/or assembling small products primarily by hand, including jewelry, pottery and other ceramics, as well as small glass and

metal art and craft products, and taxidermists. Also includes manufacturing establishments producing small products not classified in another major manufacturing group, including brooms and brushes; buttons, costume novelties; jewelry; musical instruments; pens, pencils, and other office and artists' materials; sporting and athletic goods; toys; etc.

#### B Use Definitions

**Bar/ Cocktail Lounge/ Nightclub.** Brew pub and live entertainment and/or dancing without food and service. For live entertainment see SRMC Section 14.03.030 Definitions "Live Entertainment".

**Bed and Breakfast Inn.** See SRMC Section 14.03.030 Definitions "Bed and Breakfast Inn".

**Building Materials and Supplies.** Equipment rental business, hardware store, and paint store.

**Business Sales and Services.** Establishments providing direct services to consumers. Examples of these uses include employment agencies, insurance agent offices, real estate offices, travel agencies, utility company offices, elected official satellite offices, blueprint and photocopy shop, computer service, locksmith shop, office furniture sales and rental shop, printing shop, etc. This use does not include "Financial Service and Institution" which is separately defined.

#### C Use Definitions

**Community Garden.** See SRMC Section 14.03.030 Definitions "Community Garden".

#### D Use Definitions

**Day Care Center.** As defined by California Health and Safety Code Section 1596.76, any child or adult day care facility other than a family day care home, and includes

infant centers, preschools, extended day care facilities, and school age child care centers.

**Drive-Thru Service.** Facilities where food or other products may be purchased, or services may be obtained by motorists without leaving their vehicles. Examples of drive-through sales facilities include fast-food restaurants, drive-through coffee, pharmacies, bank teller windows and ATMs, dry cleaners, etc., but do not include gas station or other vehicle services.

### E Use Definitions

**Emergency Shelter for the Homeless, Temporary.** A facility that provides temporary housing on a first-come, first-served basis where clients must leave in the morning and have no guaranteed bed for the next night OR provide beds for a specific period of time, regardless of whether or not clients leave the building. Facilities that provide temporary shelter during extremely cold weather (such as churches) are also included.

### F Use Definitions

**Financial Service and Institution.** Financial institutions, including, but not limited to: banks and trust companies, credit agencies, holding (but not primarily operating) companies, lending and thrift institutions, other investment companies, securities/commodity contract brokers and dealers, security and commodity exchanges, and vehicle finance (equity) leasing agencies. Does not include check-cashing stores.

**Fitness/ Recreation Facility, Less than 2,500 sf.** Small-scale facilities, typically accommodating no more than two groups of students at a time, in no more than two instructional spaces. Examples of these facilities include: Individual and group instruction and training in the arts; production rehearsal; photography, and the processing of photographs produced only by users of the

studio facilities; martial arts training studios; gymnastics instruction, and aerobics and gymnastics studios with no other fitness facilities or equipment. Also includes production studios for individual musicians, painters, sculptors, photographers, and other artists.

**Food Service Establishment.** See SRMC Section 14.03.030 Definitions "Food Service Establishment" and "Food Service Establishment, High Volume".

**Food Service Establishments with Alcohol Sales.** The retail sale of beer, wine, and/or spirits for on-site or off-site consumption, either as part of another retail use or as a primary business activity.

**Fueling Station.** A fuel dispensing facility exclusively serving the business occupying the subject property and not involving either wholesale or retail sales of motor vehicles fuels to other individuals or businesses. A fueling station can include mini-market, and minor repair, such as tune-ups, brakes, batteries, tires, and mufflers.

### G Use Definitions

No specialized terms beginning with the letter G are defined at this time

### H Use Definitions

**Hospital/ Major Medical Facility.** See SRMC Section 14.03.030 Definitions "Hospital". It can include also extended care facility, treatment and convalescent and children's treatment facility.

**Hotel.** See SRMC Section 14.03.030 Definitions "Hotel".

### I Use Definitions

No specialized terms beginning with the letter I are defined at this time.

### J Use Definitions

No specialized terms beginning with the letter J are defined at this time.

### K Use Definitions

No specialized terms beginning with the letter K are defined at this time.

### L Use Definitions

**Live/Work.** An integrated dwelling and working space, occupied and utilized by a single household in a structure that has been designed or structurally modified to accommodate joint residential occupancy and work activity, and which includes: Complete kitchen space and sanitary facilities in compliance with the Building Code; and Working space reserved for and regularly used by one or more occupants of the unit.

### M Use Definitions

**Medical Service.** A facility, other than a hospital, where medical, dental, mental health, surgical, and/or other personal health care services are provided on an outpatient basis. A medical office use would provide consultation, diagnosis, therapeutic, preventative or corrective treatment services by doctors, dentists, medical and dental laboratories, chiropractors, counselors, physical therapists, respiratory therapists, acupuncturists and psychiatrists, and similar practitioners of medical and healing arts for humans licensed for such practice by the state of California. Medical service uses typically require use of specialized medical equipment and medical training to evaluate, diagnose and administer treatments, medication or therapies which require a prescription (including administering oxygen or performing dialysis, and sleep diagnostics facilities); increased support staff needs; multiple patient treatment rooms; and patient waiting areas. Counseling services

and other services provided by nonmedical professionals may also be included under DTFBC 4.1.020 Use Types "Professional, Administrative."

### N Use Definitions

No specialized terms beginning with the letter N are defined at this time.

### O Use Definitions

**Office, General.** See SRMC Section 14.03.030 Definitions "Office General". It can include Professional and Administrative offices.

- **Professional, Administrative.** Office-type facilities occupied by businesses that provide professional services, or are engaged in the production of intellectual property. Examples of these uses include: Accounting, auditing and bookkeeping services, advertising agencies, attorneys, business associations, chambers of commerce, commercial art and design services, construction contractors (office facilities only), counseling services, court reporting services, design services including architecture, engineering, landscape architecture, urban planning, detective agencies and similar services, doctors, educational, scientific and research organizations, financial management and investment counseling, literary and talent agencies, management and public relations services, media post-production services, news services, photographers and photography studios, political campaign headquarters, psychologists, secretarial, stenographic, word processing, and temporary clerical employee services, security and commodity brokers, writers' and artists' offices.

### Q Use Definitions

No specialized terms beginning with the letter Q are defined at this time.

**P Use Definitions**

**Public Park, Playground, and Recreational Facility.**

For Recreational Facility see SRMC Section 14.03.030 Definitions "Recreation Facility".

**Parking Facility, Commercial or Municipal.** See SRMC Section 14.03.030 Definitions "Parking Facility" or "Parking Area".

**Personal Service.** Establishments that provide non-medical services to individuals as a primary use. Examples of these uses include: barber and beauty shops, clothing rental, dry cleaning pick-up stores with no on-site processing, home electronics and small appliance repair, laundromats (self-service laundries), locksmiths, massage (licensed, therapeutic, non-sexual), bodywork office or establishment, nail salons, pet grooming with no boarding, shoe repair shops, tailors, tanning salons. These uses may also include accessory retail sales of products related to the services provided.

**Public and Utility Facility.** Public and utility facility such as library, museum, and other cultural facility, corporation maintenance or storage yard, pump station, utility substation storm drainage pond, water tank, utility distribution facility, etc.

**R Use Definitions**

**Repairs, Major.** General repair, rebuilding or reconditioning of engines, motor vehicles or trailers; collision service including body or frame, straightening or repair, overall painting or paint shop.

**Repairs, Minor.** Incidental minor repairs to include replacement of parts and service to passenger cars, such as tune-ups, brakes, batteries, tires, mufflers and upholstery, but not including any operation defined as "automobile repair, major, or any other operation similar thereto.

**Residential Care Facility, Other.** A facility providing care and treatment in a protective living environment for persons residing voluntarily, by court placement, or under protective control of federal, State, county, or City governance including, without limitation, correctional and post-correctional facilities, juvenile detention facilities, temporary detention facilities, chronically ill tenants, domestic violence victims, outpatient clients, and developmentally disabled. It can include:

- **Nursing Home.** A health care institution other than a hospital or sheltered care home which provides inpatient or resident beds and is licensed by the State Department of Health Services as a skilled nursing facility for two or more unrelated persons. A nursing home provides services to those who need continuous care but do not require hospital care or direct daily care from a physician.
- **Sheltered Care Home.** An institutional living facility for nine –16 unrelated persons providing living facilities, sleeping rooms, and meals. The number listed does not include the operator, members of the operator’s family, or persons employed by the operator as staff, except that the total number of persons living in a Sheltered Care Home shall not exceed 18. Also includes temporary or permanent residential housing and service facilities for chronically ill tenants, domestic violence victims, and outpatient clients. It includes State licensed facilities.
- **Group Home.** A residential facility for unrelated persons providing living facilities, sleeping rooms, and meals. This category does not include a home for the developmentally disabled or other institutional uses such as protective living or sheltered care facilities.

**Residential Care Facility, Other Small (less than 7).**

A facility less than seven providing custodial care and treatment in a protective living environment for persons

residing voluntarily or by court placement including, without limitation, correctional and post-correctional facilities, juvenile detention facilities, and temporary detention facilities.

**Residential Care Facility, Other Large (more than 7).**

Residential living facilities for seven or more occupants where residents are under protective control of federal, State, county, or City governance. It includes halfway houses, work release programs, and other similar programs. Also includes residential housing and service facilities for chronically ill tenants, domestic violence victims, outpatient clients, and developmentally disabled.

**Retail General.** Stores and shops intended to serve the City as destination retail, rather than convenience shopping. Examples of these stores and lines of merchandise include:

- Antique store, apparel store, appliance store (and ancillary repair), music and photographic supply store, auction, bicycle shop, department store, discount store, drug store and pharmacy, electronics sales (televisions, radios, computers, etc.), florist shop, furniture store and upholstery shop (and ancillary repair), plant nursery and garden supply, shoe store, sporting goods store, stamp and coin shop, swimming pool supply.
- Art galleries, retail, art supplies, including framing services; books, magazines, and newspapers, cameras and photographic supplies, clothing, shoes, and accessories, collectibles (cards, coins, comics, stamps, etc.), drug stores and pharmacies, dry goods, fabrics and sewing supplies, hobby materials; home and office electronics, jewelry, luggage and leather goods, musical instruments, parts, accessories, small wares, specialty grocery store, specialty shops; sporting goods and equipment, stationery, toys and games; variety stores, videos, DVDs, records, and CDs, including rental stores.

## S Use Definitions

**School, Parochial, Private or Public.** Includes the following facilities:

- **Elementary, Middle, Secondary.** A public or private academic educational institution, including elementary (kindergarten through 6th grade), middle and junior high schools (7th and 8th grades), secondary and high schools (9th through 12th grades), and facilities that provide any combination of those levels. May also include any of these schools that also provide room and board. Does not include pre-schools and child day care facilities (see DTFBC 4.1.020 Use Types “Day Care Center”). See also the definition of “Studio: Art, Dance, Martial Arts, Music, etc.” for smaller-scale facilities offering specialized instruction.

**Specialized Education and Training.** A school that provides education and/or training, including tutoring, or vocational training, in limited subjects. Examples of these schools include: Art school, ballet and other dance school, business, secretarial, and vocational school, computers and electronics school, drama school, driver education school, establishments providing courses by mail, language school, martial arts, music school, professional school (law, medicine, etc.), Seminaries/religious ministry training facility

## T Use Definitions

No specialized terms beginning with the letter T are defined at this time.

## U Use Definitions

No specialized terms beginning with the letter U are defined at this time.

**V Use Definitions**

No specialized terms beginning with the letter V are defined at this time.

**W Use Definitions**

**Wireless Telecommunications Facilities.** Public, commercial and private electromagnetic and photoelectric transmission, broadcast, repeater and receiving stations for radio, television, telegraph, telephone, data network, and wireless communications, including commercial earth stations for satellite-based communications. Includes antennas, commercial satellite dish antennas, and equipment buildings. Does not include telephone, telegraph and cable television transmission facilities utilizing hard-wired or direct cable connections

**X Use Definitions**

No specialized terms beginning with the letter X are defined at this time.

**Y Use Definitions**

No specialized terms beginning with the letter Y are defined at this time.

**Z Use Definitions**

No specialized terms beginning with the letter Z are defined at this time.

*This page intentionally left blank*

### 4.1.030 Measurement Methods

#### Building within Facade Zone

**Applicability.** The facade zone standards apply to new buildings and additions along the front and side street of a design site.

**Methodology.** The required amount is expressed in the zone standards as a percentage. The percentage is calculated as follows through an example for the front facade zone. The same approach is to be applied to the side street, using the minimum front and rear building setbacks.

1. Identify width of design site (e.g., 50') and apply required front and side building setbacks (e.g., 5' and 5').
2. Subtract the horizontal length between each side setback and the adjacent side design site line from the total width of the design site. The result is net buildable width of the design site (e.g., 40').
3. Multiply the required minimum percentage in the zone standards (e.g., 50%) by the net buildable width of the design site (e.g., 50').
4. The result is the minimum length, in feet, of building facade that shall be placed in or abutting the facade zone (e.g., 20').
5. See DTFBC Figure 4.1.030.B (Applying the Required amount to the Facade Zone) for examples that are consistent with the intent of this standard.

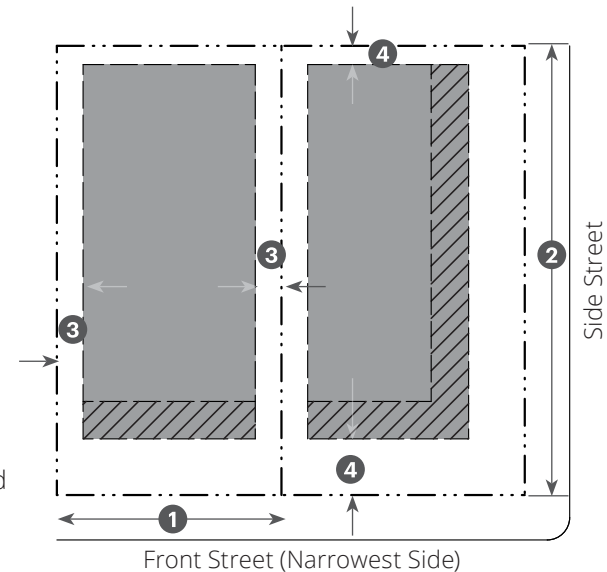

**Figure 4.1.030.A** Determining the Required Amount Subject to the Facade Zone

**Table 4.1.020.A Example Calculation**

50'	Design Site Width
- 5'	Side Setback
- 5'	Side Setback
= 40'	Net Buildable Width
40'	Net Buildable Width
x Zone Standard	(e.g., 50%)
= 20'	Required In or Abutting the Facade Zone

**Key**

- ① Width of Design Site
- ② Depth of Design Site
- ③ Setback to be subtracted from Design Site Width
- ④ Setback to be subtracted from Design Site Depth

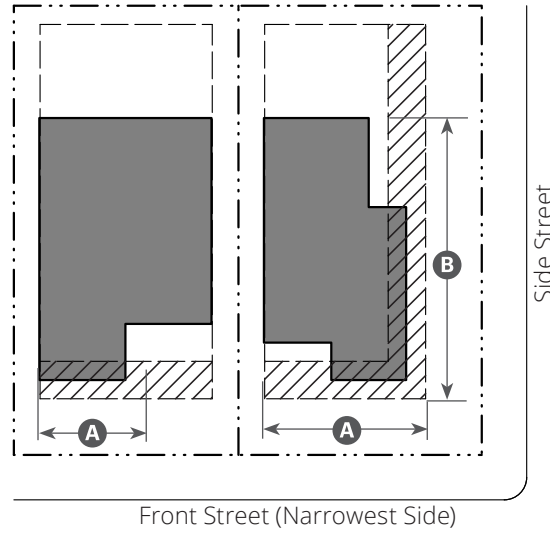

**Figure 4.1.030.B** Applying the Required amount to the Facade Zone

*Abutting Facade Zone*



*Within Facade Zone*



*Abutting and Within Facade Zone*

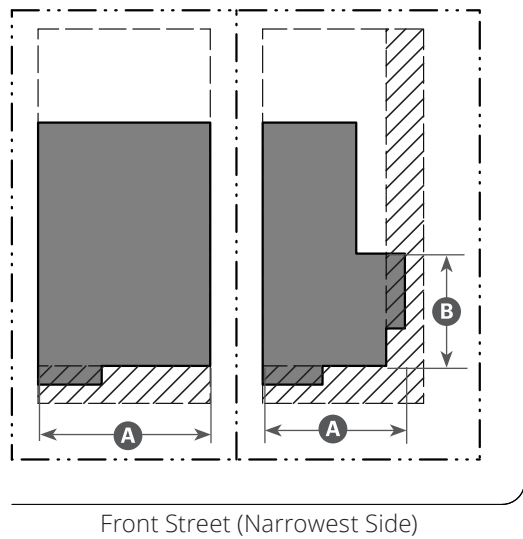

*At Front of Facade Zone*

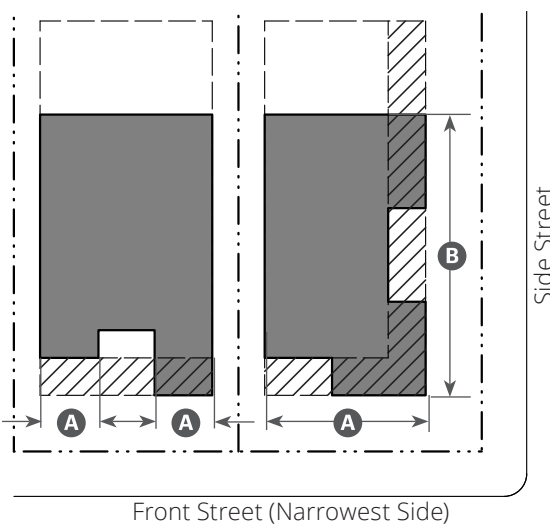

**Key**

/// Facade Zone

■ Buildable Area

**Front Street**

**Side Street**

Ⓐ 50% min.

Ⓑ 50% min.

**Highest Top Plate**

**A Height, Overall.** The vertical distance between adjacent finished grade and the highest part of the structure directly above.

**B Top of Parapet**

**C Roof Structure**

**D Highest Top Plate.** The vertical distance between adjacent finished grade and the highest top plate/eave of the building.

- For buildings with a pitched roof the measurement is to the highest eave.
- For buildings with a parapet and flat roof, the measurement is to the highest top plate.
- For buildings with a parapet and flat roof, the top plate of the parapet is not considered the highest top plate of the building.

**E Highest Eave Measurement.** The measurement is to bottom of the eave assembly.

**F Eave.** The edge of the roof that overhangs the face of the wall. The bottom of the eave can range from the exposed rafters to a finished horizontal surface.

**G Dormer**

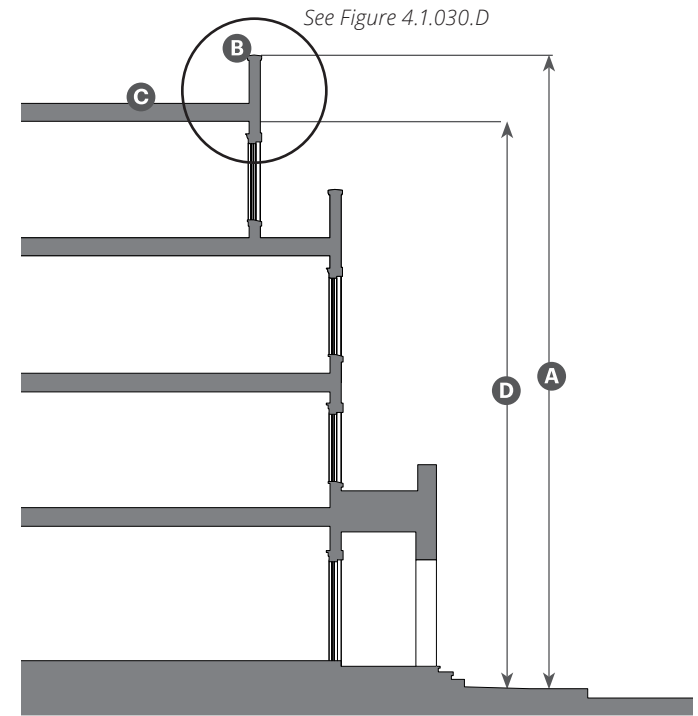

**Figure 4.1.030.C** Highest Top Plate for parapet and flat roof.

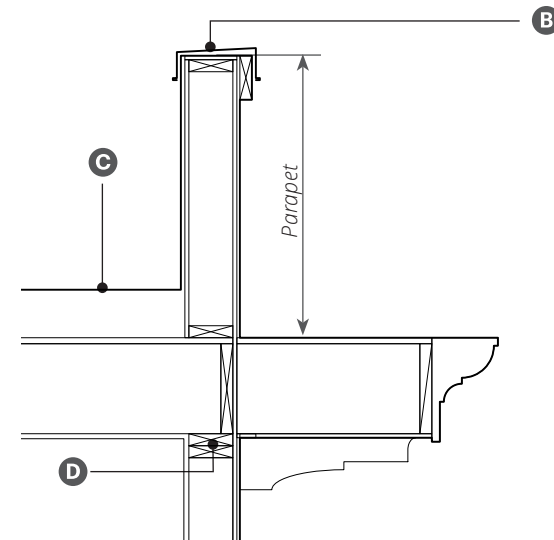

**Figure 4.1.030.D** Section detail of Highest Top Plate for parapet and flat roof.

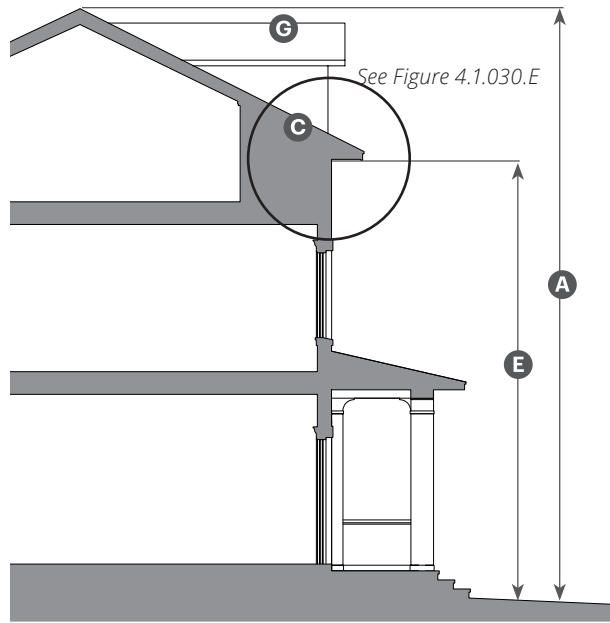

Figure 4.1.030.E Highest Top Plate for pitched roof.

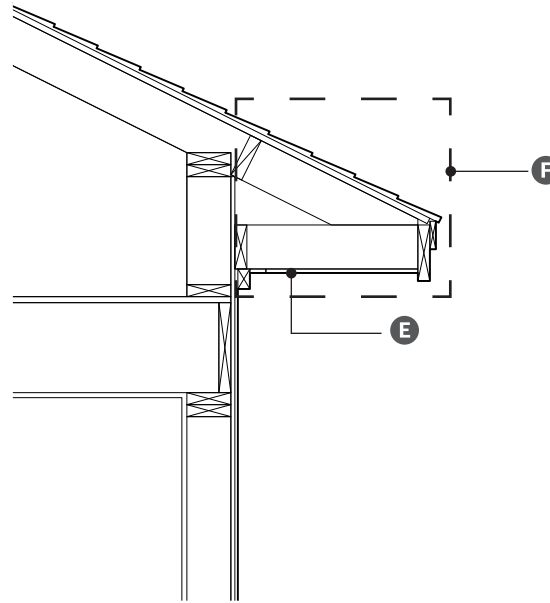

Figure 4.1.030.E Section detail of Highest Top Plate for pitched roof.

### Height Measurement on Sloped Sites

**Applicability.** All sites where average slope is greater than 6 percent or as determined by the Director.

Building height and height bonus is measured vertically from the existing grade to the highest top plate at any given point.

On sites with topography, additional height may be considered under SRMC Section 14.24.020.E

- A Stepback Height** as specified in the Zone Standards
- B Allowed Height Bonus** as specified in the Zone Standards
- C Upper Story Setback** as specified in the Zone Standards

 Height measurement parallel to slope

 Building profile

 **Bonus floors.** Additional height obtained through the height bonus

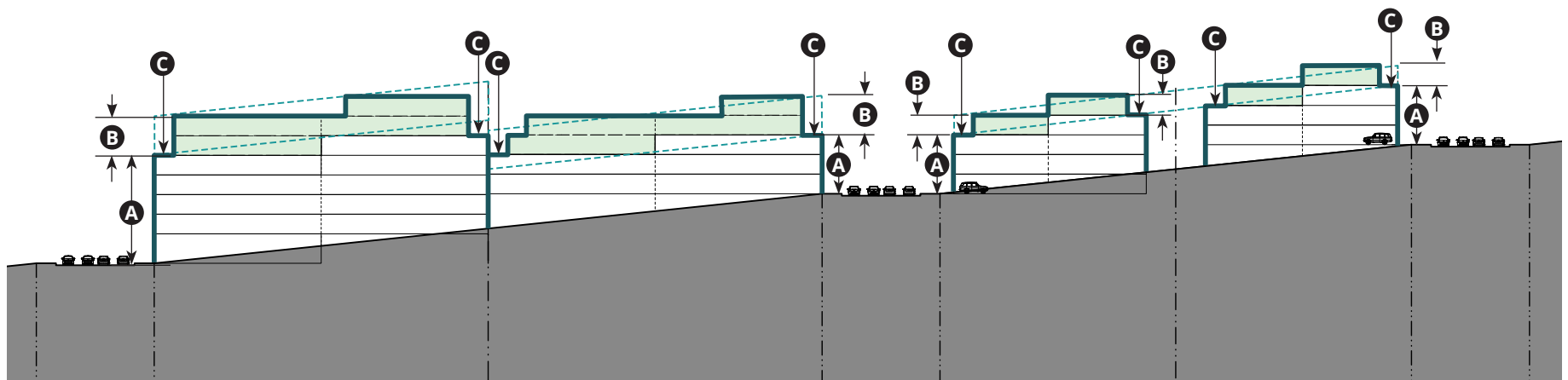

*This page intentionally left blank*

