

Preliminary Stormwater Control Plan
For a Regulated Project
88 Vivian Street Project, San Rafael

Prepared Date: March 2021

Revised: September 2021

This template is to be used in conjunction with the instructions, criteria, and minimum requirements in the Bay Area Stormwater Management Agencies Association's (BASMAA's) *Post-Construction Manual*.

This Stormwater Control Plan was prepared using the template dated October 2018.

Prepared for:

Ashton 3, LLC
5 Hoya Street
Rancho Mission Viejo, California 32694
Matt Ashton
Phone: 949.584.2042

Prepared by:

C&V Consulting, Inc.
9830 Irvine Center Drive
Irvine, California 92618
949-916-3800

Table of Contents

I.	Project Data	1	
II.	Setting		
	II.A. Project Location and Description	1	
	II.B. Existing Site Features and Conditions	1	
	II.C. Opportunities and Constraints for Stormwater Control		2
III.	Low Impact Development Design Strategies	2	
	III.A. Optimization of Site Layout	2	
	III.B. Use of Permeable Pavements	2	
	III.C. Dispersal of Runoff to Pervious Areas	2	
	III.D. Stormwater Control Measures	2	
IV.	Documentation of Drainage Design	3	
	IV.A. Descriptions of Each Drainage Management Area		3
	IV.A.1. Drainage Management	3	
	IV.A.2. Drainage Management Area Descriptions		3
V.	Source Control Measures	4	
	V.A. Site activities and potential sources of pollutants		4
	V.B. Source Control Table	4	
VI.	Stormwater Facility Maintenance	7	
	VI.A. Ownership and Responsibility for Maintenance in Perpetuity		7
	VI.B. Summary of Maintenance Requirements for Each Stormwater Facility		7
VII.	Construction Checklist	7	
VIII.	Certifications	7	

Tables

Table 1. Project Data	1
Table 2. Drainage Management Area	3
Table 3. Areas Draining to Bio-filtration Facility	4
Table 4. Potential Pollutant Sources and Source Control Measures	4
Table 5. Construction Plan C.3 Checklist	7

Figures

Figure 1. Vicinity Map	1
------------------------	---

Attachments

Stormwater Control Plan Exhibit
Modular Wetland System Detail
Modular Wetland System Specification
Modular Wetland System Maintenance Guidelines
Geotechnical Investigation

I. Project Data

Table 1. Project Data Form

Project Name/Number	88 Vivian Street Project
Application Submittal Date	[to be verified by municipal staff]
Project Location	88 Vivian Street, San Rafael, California APN: 008-092-02
Project Phase No.	N/A
Project Type and Description	Residential with 68 dwelling units
Total Project Site Area (acres)	2.408 acres
Total New and Replaced Impervious Surface Area	0
Total Pre-Project Impervious Surface Area	2.308 acres
Total Post-Project Impervious Surface Area	2.104 acres

II. Setting

II.A. Project Location and Description

The project consists of 68 residential dwelling units located at 88 Vivian Road, in the City of San Rafael, California. The development includes private garages, private drive aisles, sidewalks, guest parking area, and common landscaped areas. The Project site is bounded by Vivian Street to the north-westerly side, Belvedere Street to the north-easterly side, and Commercial buildings to the south-easterly and south-westerly side.

Figure 1. Vicinity Map

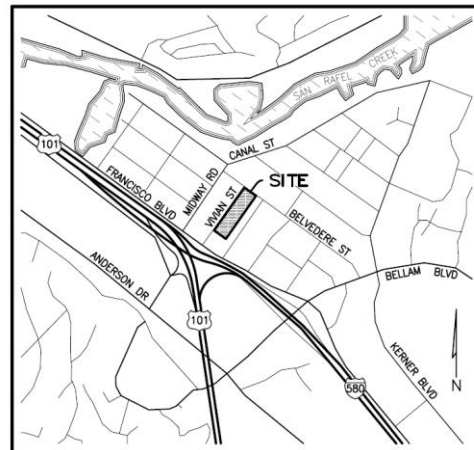

II.B. Existing Site Features and Conditions

The site currently contains an existing closed bowling alley building of around 37,000 square feet and associated parking lot on a single lot, APN: 008-092-02. Based on USDS Soil Map, the site in soil type urban land-xerotherents complex, which slopes at 0 to 9 percent. There are no swales or other natural drainage features, and there are no storm drains on site.

II.C. Opportunities and Constraints for Stormwater Control

Disposal of runoff to deep infiltration is not feasible on this site due to the high water table and low permeability of the clay soils. The planned development includes landscaped area surrounding the buildings, which allows portion of the runoff generated from building roofs to be mitigated. All runoffs from the site eventually mitigates to downstream catch basin with proposed bio-filtration facility - Modular Wetland System for the treatment flow. Treated runoff will be mitigate out of the site via storm drain to Belvedere Street.

Refer to separate prepared hydrology and hydraulic study for additional proposed on-site runoff outlet information.

III. Low Impact Development Design Strategies

III.A. Optimization of Site Layout

The site will be rezoned to Residential from Commercial zoning district. The street widths, sidewalks, driveways are the minimum allowable consistent with the City standards and fire district requirement to minimize impervious surfaces.

III.B. Use of Permeable Pavements

Conventional concrete and asphalt are to be used to construct the street, sidewalks, and driveways. The underlying clay soil condition would require a deep and large quantities of excavation and off-haul for the application of permeable pavements, which is not cost-effective for the proposed project site.

III.C. Dispersal of Runoff to Pervious Areas

Runoffs to pervious areas are maximized with roof drains that will dispersed to nearby landscaped areas. The landscaped area will be graded to retain a volume equal to one inch of rainfall from portion of roof areas. The grading will not interfere with the overall flow paths direction runoffs around the building pads and outlet to the street. Portion of the roof runoff from the building facing the public street will be routed via downspout connection with drainage pipe to the bio-filtration facility.

III.D. Stormwater Control Measures

Runoff from the street will be routed to the street gutter to enter high-flowrate treatment area through curb inlet or storm drain system routing located at the low point of west entrance from Vivian Street. The facilities are designed to the high-flowrate type bio-filters technical criteria for non-LID in the BASMAA Post-Construction Manual to minimize facility surface area. All drainage shall be confirmed with Final Engineering Site plan and maximize dispersion of runoff to nearby landscaped areas.

IV. Documentation of Drainage Design

IV.A. Descriptions of Each Drainage Management Area

IV.A.1. Drainage Management

Table 2. Drainage Management Areas

DMA Name	Name	Surface Type	Area (square feet)
1A	Homesites	Roof	21,499.28
1B	Homesites	Roof Drain to Landscape	26,247.24
2	Street	Asphalt/ Concrete	35,608.74
3	Hardscape	Asphalt/ Concrete	8,300.96
4	Landscape	Ornamental Landscaping	13,123.62
5	Bio-filtration	Manufacturing specification	117.00

IV.A.2. Drainage Management Area Descriptions

DMA 1A, totaling 21,499.28 square feet, drains to street to downstream catch basin with Modular Wetland System via D-vert system.

DMA 1B, totaling 26,247.24 square feet, drains to nearby landscape self-retaining area (DMA-4) via roof drain pipe.

DMA 2, totaling 35,608.74 square feet, drains via gutters to downstream catch basin with Modular Wetland System.

DMA 3, totaling 8,300.96 square feet, drains to street to downstream catch basin with Modular Wetland System

DMA 4, totaling 13,123.62 square feet, self-retaining landscape area.to be graded slightly concave to promote runoff retention. Area will receive runoff from nearby building roofs.

DMA 5, totaling 117 square feet, bio-filtration system that collects low flow from catch basin and drains through D-vert system to storm drain system to pump out towards Vivian Street.

Tabulation and Sizing Calculations

Table 3. Areas Draining to Bio-filtration Facilities

DMA Name	DMA Area (square feet)	Post-project surface type	DMA Runoff factor	DMA Area × runoff factor	Facility Name		
					MWS-L-8-12-C		
DMA-1A	21,499.28	Roof	1	21,499.28	Sizing factor	Minimum Facility Flowrate (cfs)	Proposed Facility Flowrate (cfs)
DMA-2	35,608.74	Asphalt/Concrete	1	35,608.74			
DMA-3	8,300.96	Asphalt/Concrete	1	8,300.96			
Total>					0.2 in/hr	0.3028	0.346

Refer to Attachment for spreadsheet calculation and bio-filtration facility specifications.

V. Source Control Measures

V.A. Site activities and potential sources of pollutants

On-site activities that could potentially produce stormwater pollutants include:

- On-site Storm Drain Inlets
- Landscape/ Outdoor Pesticide Use/ Building and Ground Maintenance
- Roofing, gutters, and trim
- Plazas, sidewalks, and parking lots

V.B. Source Control Table

Table 4. Pollutant Sources and Source Control Measures

Potential source of runoff pollutants	Permanent source control BMPs	Operational source control BMPs
On-site Storm Drain Inlets	Mark all inlets with the words “No Dumping! Flows to Bay” or similar	Maintain and periodically repaint or replace inlet markings. Provide stormwater pollution prevention information to new site owners, lessees, or operators. See applicable operational BMPs in Fact Sheet SC-44, “Drainage System Maintenance,” in the CASQA Stormwater

		<p>Quality Handbooks at www.casqa.org/resources/bmphandbooks</p> <p>Include the following in lease agreements: “Tenant shall not allow anyone to discharge anything to storm drains or to store or deposit materials so as to create a potential discharge to storm drains.”</p>
Landscape/ Outdoor Pesticide Use/ Building and Ground Maintenance	<p>Preserve existing native trees, shrubs, and ground cover to the maximum extent possible.</p> <p>Design landscaping to minimize irrigation and runoff, to promote surface infiltration where appropriate, and to minimize the use of fertilizers and pesticides that can contribute to stormwater pollution.</p> <p>Where landscaped areas are used to retain or detain stormwater, specify plants that are tolerant of saturated soil conditions.</p> <p>Consider using pest-resistant plants, especially adjacent to hardscape.</p> <p>To insure successful establishment, select plants appropriate to site soils, slopes, climate, sun, wind, rain, land use, air movement, ecological consistency, and plant interactions.</p>	<p>Maintain landscaping using minimum or no pesticides.</p> <p>See applicable operational BMPs in Fact Sheet SC-41, “Building and Grounds Maintenance,” in the CASQA Stormwater Quality Handbooks at www.casqa.org/resources/bmphandbooks</p> <p>Provide IPM information to new owners, lessees and operators.</p>
Roofing, gutters, and trim	<p>Condensate drain lines may discharge to landscaped areas if the flow is small enough that runoff will not occur.</p> <p>Condensate drain lines may not discharge to the storm drain system.</p> <p>Rooftop equipment with potential to produce pollutants shall be roofed</p>	

	and/or have secondary containment.	
Plazas, sidewalks, and parking lots		Sweep plazas, sidewalks, and parking lots regularly to prevent accumulation of litter and debris. Collect debris from pressure washing to prevent entry into the storm drain system. Collect washwater containing any cleaning agent or degreaser and discharge to the sanitary sewer not to a storm drain.

VI. Stormwater Facility Maintenance

VI.A. Ownership and Responsibility for Maintenance in Perpetuity

The property is currently owned by Ashton 3, LLC. The Owner will be responsible for the long-term maintenance of the project's storm water facilities and conformance to this storm water control plan after construction is complete.

The owner is aware of the maintenance responsibilities of the proposed BMPs. A funding mechanism is in place to maintain the BMPs. Maintenance Mechanism will be assigned to a Home Owners' Association or Property Owners Association.

VI.B. Summary of Maintenance Requirements for Each Stormwater Facility

The attachment includes specific BMP detail information pertaining to operation and maintenance guidelines.

Inspections will be conducted as follows:

- Annually and prior to the start of the rainy season
- Every (1) month during rainy season
- At any other time(s) or intervals of time specified in the contract documents

Repairs and/ or maintenance procedures shall be carried out at the soonest possible time.

VII. Construction Checklist

Table 5. Construction Plan Checklist

Reference Plan Page #	Source Control or Treatment Control Measure
Exhibit	Bio-filtration facility - Modular Wetland System
Grading/ SD plan	Catch Basins, Storm Drain Pump, Storm Drain Pipe

VIII. Certifications

The preliminary design of stormwater treatment facilities and other stormwater pollution control measures in this plan are in accordance with the current edition of the BASMAA *Post-Construction Manual*.

Attachments

Stormwater Control Plan Exhibit

Modular Wetland System Detail

Modular Wetland System Specification

Modular Wetland System Maintenance Guidelines

Geotechnical Investigation

STORM WATER CONTROL PLAN EXHIBIT

88 VIVIAN STREET

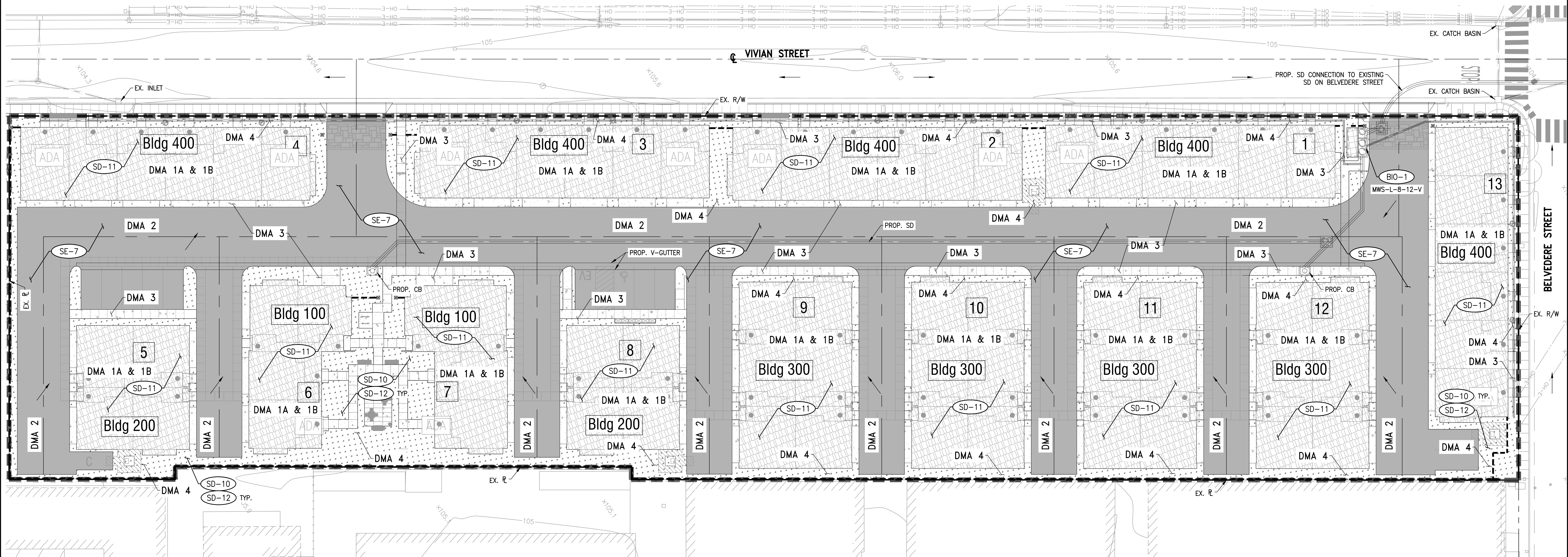
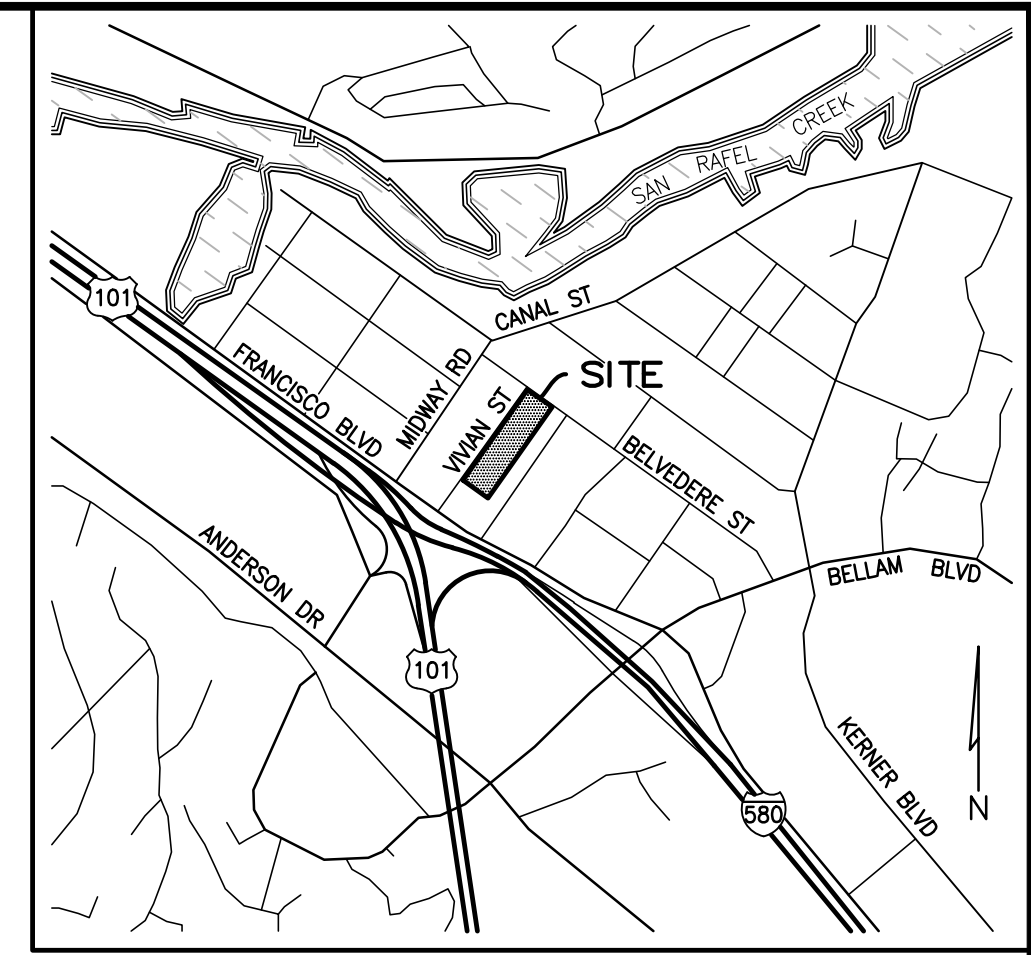

DMA	NAME	SURFACE TYPE	AREA (SF)
1A	HOMESITES	ROOF	21,499.28
1B	HOMESITES	ROOF DRAIN TO LANDSCAPE	26,247.24
2	STREET	ASPHALT/CONCRETE	35,608.74
3	HARDSCAPE	ASPHALT/CONCRETE	8,300.96
4	LANDSCAPE	ORNAMENTAL LANDSCAPING	13,123.62
5	BIO-FILTRATION	MANUFACTURING SPECIFICATION	117.00

LEGEND:

- DRAINAGE MANAGEMENT AREA (DMA) BOUNDARY
- FLOW DIRECTION
- PORTLAND CONCRETE CEMENT (PCC) PAVEMENT AREA
- ASPHALT CONCRETE (AC) PAVEMENT AREA
- ROOF TOP AREA
- BIO-FILTRATION AREA
- LANDSCAPE

BEST MANAGEMENT PRACTICES:

- PRIVATE STREET SWEEPING
- SITE DESIGN & LANDSCAPE PLANNING
- ROOF RUNOFF CONTROLS
- EFFICIENT IRRIGATION
- STORM DRAIN SIGNAGE
- DRAINAGE SYSTEM MAINTENANCE
- HIGH-FLOW RATE BIO-FILTRATION AREA

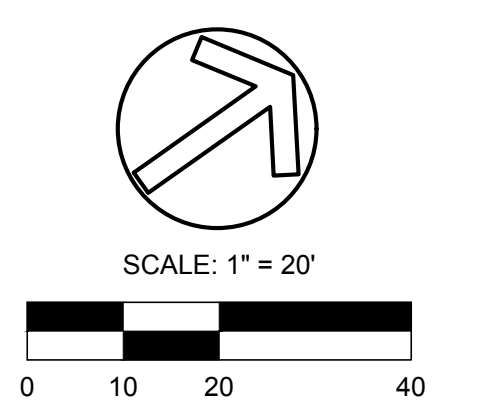

MARK	REVISIONS	APPR.	DATE
DESIGNED BY	DRAWN BY	CHECKED BY	

CITY OF SAN RAFAEL
88 VIVIAN STREET

PROJ: BIRK028 DWG: P:\ASST\City\88Vivian\88VivianStormWaterControlPlan.dwg, BY: NAB, Sep 11, 2021, 5:18:19pm

VAULT-BASED HIGH-FLOWRATE

Total Site Area:		BIORETENTION FACILITIES														
DMA Names	Area	Self-Treating	Self-Retaining	Runoff Factor	Drains to Self-Retaining	Name of Receiving DMA	Facility 1	Facility 2	Facility 3	Facility 4	Facility 5	Facility 6	Facility 7	Facility 8	Facility 9	Facility 10
DMA-1A	21499.28			1		DMA-5	21499.28									
DMA-1B	26247.24			1	26247.24	DMA-4										
DMA-2	35608.74			1		DMA-5	35608.74									
DMA-3	8300.96			1		DMA-5	8300.96									
DMA-4	13123.62		13123.62			DMA-5										
DMA-5	117	117														
Total DMAs (square feet)	104896.8	117	13123.62		26247.24		65408.98	0	0	0	0	0	0	0	0	0
Total Facilities						*Minimum Size (CFS)	0.3028	0.0000	0.0000	0.0000	0.0000	0.0000	0.0000	0.0000	0.0000	0.0000
DMAs + Facilities	OK					Treatment Flow	0.346	OK	OK	OK	OK	OK	OK	OK	OK	OK

*Required CFS is calculated with the factor of 2 in/hr per Technical Criteria for non-LID treatment facilities Document

MWS LINEAR 2.0 HGL SIZING CALCULATIONS



MWS MODEL SIZE	WETLAND PERMITTER LENGTH	LOADING RATE GPM/SF	HGL HEIGHT																																
			SHALLOW MODELS																				STANDARD HEIGHT MODEL	HIGH CAPACITY MODELS											
			1.4	1.5	1.6	1.7	1.8	1.9	2.0	2.1	2.2	2.3	2.4	2.5	2.6	2.7	2.8	2.9	3.0	3.1	3.2	3.3		3.4	3.5	3.6	3.65	3.70	3.75	3.80	3.85	3.90	3.95		
MWS-L-4-4	6.70	1.0	0.022	0.023	0.025	0.026	0.028	0.029	0.031	0.032	0.034	0.035	0.037	0.038	0.040	0.042	0.043	0.045	0.046	0.048	0.049	0.051	0.052	0.054	0.055	0.056	0.057	0.058	0.058	0.059	0.060	0.061			
MWS-L-5-6	10.00	1.0	0.032	0.033	0.037	0.039	0.042	0.044	0.046	0.048	0.051	0.053	0.055	0.058	0.060	0.062	0.063	0.067	0.069	0.072	0.074	0.076	0.076	0.081	0.083	0.084	0.085	0.087	0.088	0.089	0.090	0.091			
MWS-L-4-6	9.30	1.0	0.030	0.032	0.034	0.036	0.038	0.041	0.043	0.045	0.047	0.049	0.051	0.053	0.055	0.058	0.060	0.062	0.064	0.066	0.068	0.070	0.073	0.075	0.077	0.078	0.079	0.080	0.081	0.082	0.083	0.084			
MWS-L-4-8	14.80	1.0	0.048	0.051	0.054	0.058	0.061	0.065	0.068	0.071	0.075	0.078	0.082	0.085	0.088	0.092	0.095	0.099	0.102	0.105	0.109	0.112	0.115	0.119	0.122	0.124	0.126	0.127	0.129	0.131	0.132	0.134			
MWS-L-4-13	18.40	1.0	0.059	0.063	0.068	0.072	0.076	0.080	0.084	0.089	0.093	0.097	0.101	0.106	0.110	0.114	0.118	0.122	0.127	0.131	0.135	0.139	0.144	0.148	0.152	0.154	0.156	0.158	0.160	0.163	0.165	0.167			
MWS-L-4-15	22.40	1.0	0.072	0.077	0.082	0.087	0.093	0.098	0.103	0.108	0.113	0.118	0.123	0.129	0.134	0.139	0.144	0.149	0.154	0.159	0.165	0.170	0.175	0.180	0.185	0.188	0.190	0.193	0.195	0.198	0.200	0.203			
MWS-L-4-17	26.40	1.0	0.085	0.091	0.097	0.103	0.109	0.115	0.121	0.127	0.133	0.139	0.145	0.151	0.158	0.164	0.170	0.176	0.182	0.188	0.194	0.200	0.206	0.212	0.218	0.221	0.224	0.227	0.230	0.233	0.236	0.239			
MWS-L-4-19	30.40	1.0	0.098	0.105	0.112	0.119	0.126	0.133	0.140	0.147	0.153	0.160	0.167	0.174	0.181	0.188	0.195	0.202	0.209	0.216	0.223	0.230	0.237	0.244	0.251	0.255	0.258	0.262	0.265	0.269	0.272	0.276			
MWS-L-4-21	34.40	1.0	0.111	0.118	0.126	0.134	0.142	0.150	0.158	0.166	0.174	0.182	0.189	0.197	0.205	0.213	0.221	0.229	0.237	0.245	0.253	0.261	0.268	0.276	0.284	0.288	0.292	0.296	0.300	0.304	0.308	0.312			
MWS-L-6-8	18.80	1.0	0.060	0.065	0.069	0.073	0.078	0.082	0.086	0.091	0.095	0.099	0.104	0.108	0.112	0.116	0.121	0.125	0.129	0.134	0.138	0.142	0.147	0.151	0.155	0.157	0.160	0.162	0.164	0.166	0.168	0.170			
MWS-L-8-8	29.60	1.0	0.095	0.102	0.109	0.115	0.122	0.129	0.136	0.143	0.149	0.156	0.163	0.170	0.177	0.183	0.190	0.197	0.204	0.211	0.217	0.224	0.231	0.238	0.245	0.248	0.251	0.255	0.258	0.262	0.265	0.268			
MWS-L-8-12	44.40	1.0	0.143	0.153	0.163	0.173	0.183	0.194	0.204	0.214	0.224	0.234	0.245	0.255	0.265	0.275	0.285	0.296	0.306	0.316	0.326	0.336	0.346	0.357	0.367	0.372	0.377	0.382	0.387	0.392	0.397	0.402			
MWS-L-8-16	59.20	1.0	0.190	0.204	0.217	0.231	0.245	0.258	0.272	0.285	0.299	0.312	0.326	0.340	0.353	0.367	0.380	0.394	0.408	0.421	0.435	0.448	0.462	0.476	0.489	0.496	0.503	0.509	0.516	0.523	0.530	0.537			
MWS-L-8-20	74.00	1.0	0.238	0.255	0.272	0.289	0.306	0.323	0.340	0.357	0.374	0.391	0.408	0.425	0.442	0.459	0.476	0.493	0.509	0.526	0.543	0.560	0.577	0.594	0.611	0.620	0.628	0.637	0.645	0.654	0.662	0.671			
MWS-L-10-20 or MWS-L-8-24	88.80	1.0	0.285	0.306	0.326	0.346	0.367	0.387	0.408	0.428	0.448	0.469	0.489	0.509	0.530	0.550	0.571	0.591	0.611	0.632	0.652	0.673	0.693	0.713	0.734	0.744	0.754	0.764	0.774	0.785	0.795	0.805			
4'x'4 media cage	14.80	1.0	0.048	0.051	0.054	0.058	0.061	0.065	0.068	0.071	0.075	0.078	0.082	0.085	0.088	0.092	0.095	0.099	0.102	0.105	0.109	0.112	0.115	0.119	0.122	0.124									

SITE SPECIFIC DATA*			
PROJECT NAME			
PROJECT LOCATION			
STRUCTURE ID			
PERFORMANCE DATA			
TREATMENT VOLUME (CF)			
DRAINDOWN TIME (HR)			
TREATMENT HGL (FT)			
BYPASS FLOW RATE (CFS)			
PROJECT PARAMETERS			
PIPE DATA	I.E.	MATERIAL	DIAMETER
INLET PIPE 1			
OUTLET PIPE 1			
RIM ELEVATION			
SURFACE LOADING REQUIREMENT			
FRAME & COVER	PRETREATMENT	BIOFILTRATION	DISCHARGE
WETLANDMEDIA VOLUME (CY)			
MEDIA DELIVERED			
ORIFICE SIZE (DIA)			
MAX PICK WEIGHT (LBS)			
NOTES:			
*PER ENGINEER OF RECORD			

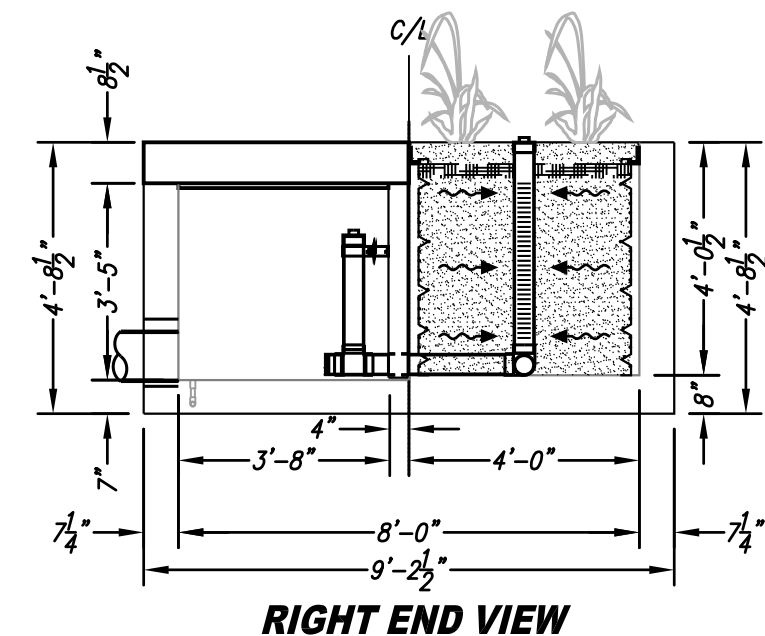
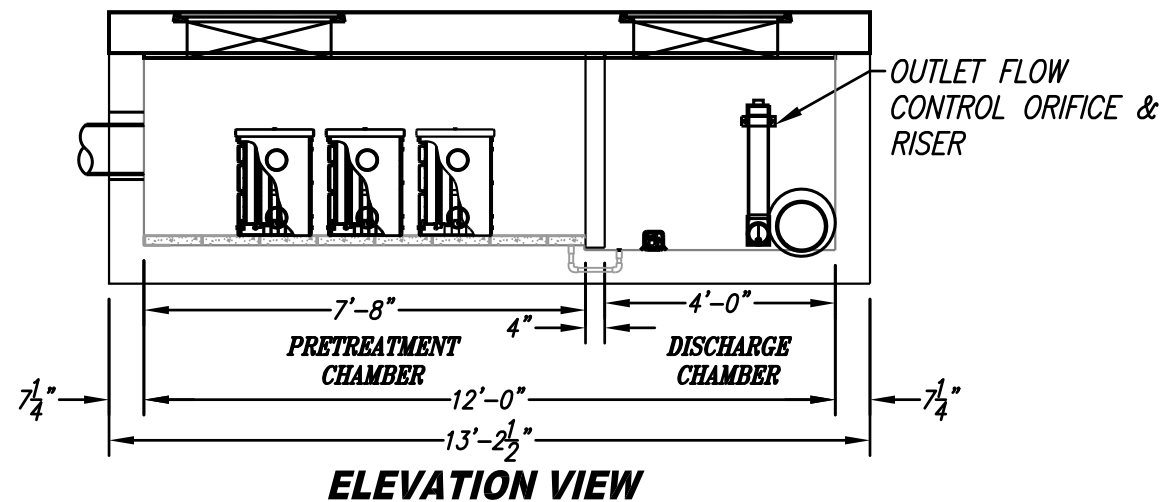
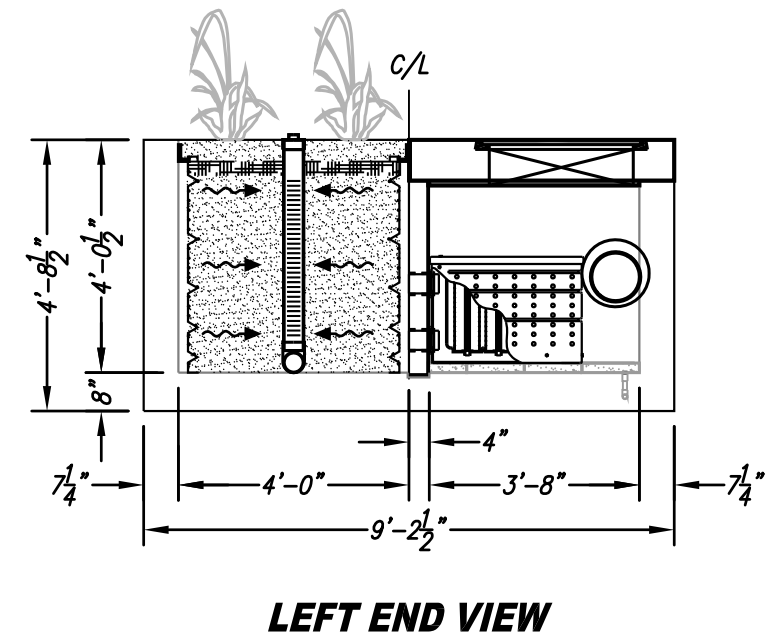
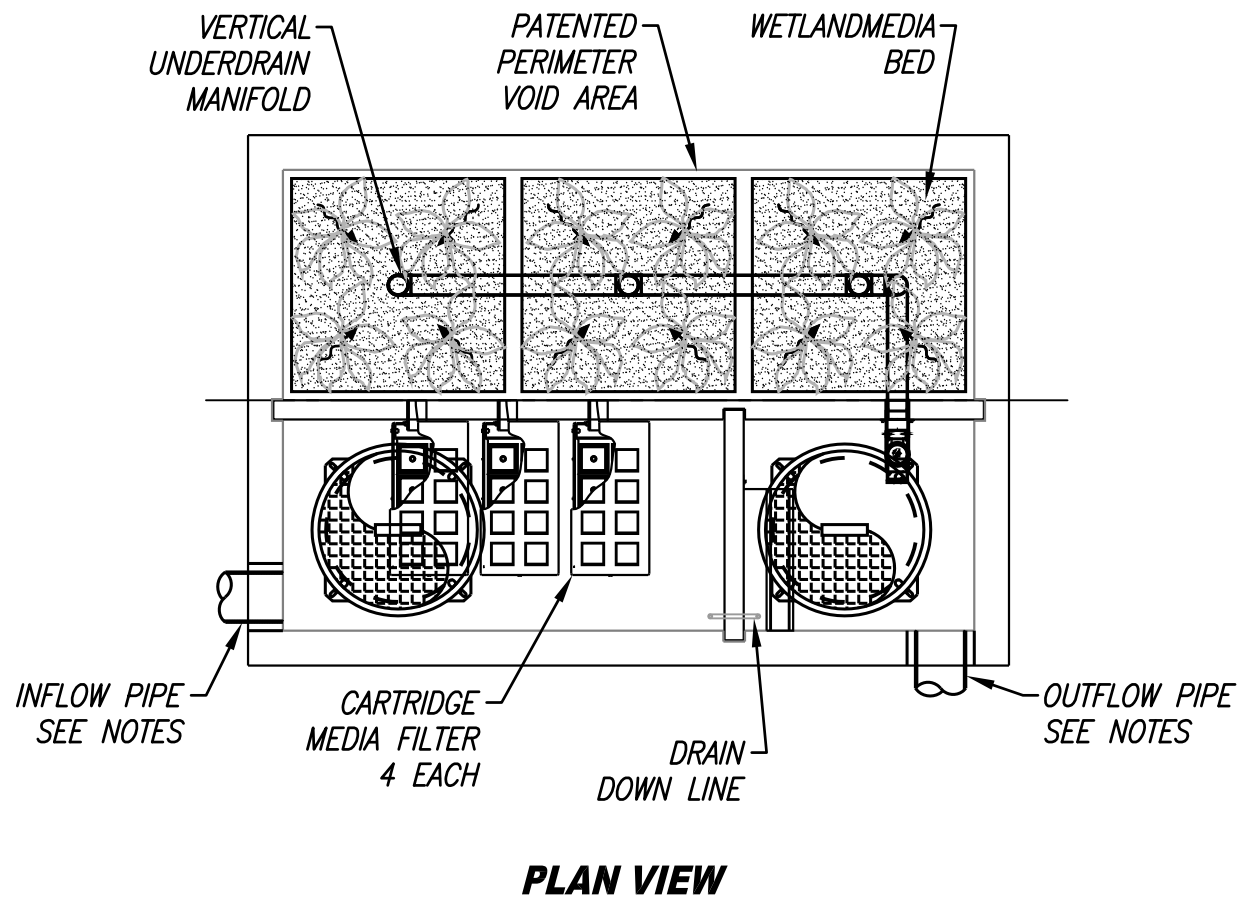

INSTALLATION NOTES

1. CONTRACTOR TO PROVIDE ALL LABOR, EQUIPMENT, MATERIALS AND INCIDENTALS REQUIRED TO OFFLOAD AND INSTALL THE SYSTEM AND APPURTENANCES IN ACCORDANCE WITH THIS DRAWING AND THE MANUFACTURERS SPECIFICATIONS, UNLESS OTHERWISE STATED IN MANUFACTURERS CONTRACT.
2. MANUFACTURER RECOMMENDS A MINIMUM 6" LEVEL ROCK BASE UNLESS SPECIFIED BY THE PROJECT ENGINEER. CONTRACTOR IS RESPONSIBLE TO VERIFY PROJECT ENGINEERS RECOMMENDED BASE SPECIFICATIONS.
3. ALL PIPES MUST BE FLUSH WITH INSIDE SURFACE OF CONCRETE. (PIPES CANNOT INTRUDE BEYOND FLUSH).
4. INVERT OF OUTFLOW PIPE MUST BE FLUSH WITH DISCHARGE CHAMBER FLOOR.
5. ALL GAPS AROUND PIPES SHALL BE SEALED WATER TIGHT WITH A NON-SHRINK GROUT PER MANUFACTURERS STANDARD CONNECTION DETAIL AND SHALL MEET OR EXCEED REGIONAL PIPE CONNECTION STANDARDS.
6. CONTRACTOR RESPONSIBLE FOR INSTALLATION OF ALL RISERS, MANHOLES, AND HATCHES. CONTRACTOR TO GROUT ALL MANHOLES AND HATCHES TO MATCH FINISHED SURFACE UNLESS SPECIFIED OTHERWISE.

GENERAL NOTES

1. MANUFACTURER TO PROVIDE ALL MATERIALS UNLESS OTHERWISE NOTED.
2. ALL DIMENSIONS, ELEVATIONS, SPECIFICATIONS AND CAPACITIES ARE SUBJECT TO CHANGE. FOR PROJECT SPECIFIC DRAWINGS DETAILING EXACT DIMENSIONS, WEIGHTS AND ACCESSORIES PLEASE CONTACT MANUFACTURER.

THE PRODUCT DESCRIBED MAY BE PROTECTED BY ONE OR MORE OF THE FOLLOWING US PATENTS: 7,425,262; 7,470,362; 7,674,378; 8,303,816; RELATED FOREIGN PATENTS OR OTHER PATENTS PENDING

PROPRIETARY AND CONFIDENTIAL:
THE INFORMATION CONTAINED IN THIS DRAWING IS THE SOLE PROPERTY OF MODULAR WETLANDS SYSTEMS. ANY REPRODUCTION IN PART OR AS A WHOLE WITHOUT THE WRITTEN PERMISSION OF MODULAR WETLANDS SYSTEMS IS PROHIBITED.



MWS UNIT DESIGN DATA	
TREATMENT CAPACITY (CFS)	0.346
OPERATING HEAD (FT)	3.4
PRETREATMENT SURFACE AREA (SF)	105.84
WETLAND LOADING RATE (GPM/MIN)	1.04

MWS-L-8-12-V
STORMWATER BIOFILTRATION SYSTEM
STANDARD DETAIL

SPECIFICATIONS

MWS – Linear

Hybrid Stormwater Filtration System



MWS – Linear

Hybrid Stormwater Filtration System

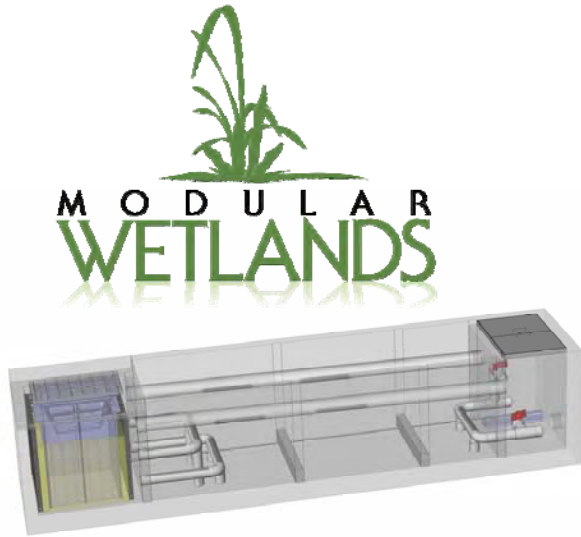

Save valuable space with small footprint for urban sites.

Improve BMP aesthetics with attractive native and tropical landscape plants.

Reduce lifetime costs with safer and less expensive maintenance

“The MWS – Linear hybrid stormwater treatment system is described as a self contained treatment train. This system utilizes an innovative combination of treatment processes. Stormwater runoff flows into the system via pipe or curb/grate type catch basin opening. Polluted runoff first encounters a screening device to remove larger pollutants and then enters a hydrodynamic separation chamber which settles out the sediments and larger suspended solids. Next the runoff is treated by a revolutionary filter media, BioMediaGREEN that removes fines and associated pollutants, including bacteria. From there runoff enters a bioretention filter in the form of a subsurface flow vegetated gravel wetland. Within the wetland physical, chemical, and biological mechanisms remove the remaining particulate and dissolved pollutants. The purified runoff leaves the system via the discharge chamber. In the discharge chamber the rate of discharge is controlled by valves set to a desired rate”.

Tested Pollutant Removal Efficiencies:

TSS Removal	Dissolved Lead Removal	Dissolved Copper Removal	TPH	E. coli Removal	Turbidity Removal
98%	81%	92%	99%	60.2%	92%

“Nature and Harmony Working Together in Perfect Harmony”

SPECIFICATIONS – MWS- LINEAR

Track Record: The MWS- Linear Hybrid Stormwater Treatment System is manufactured by a company whom is regularly engaged in the engineering design and production of treatment systems for stormwater.

Coverage: The MWS- Linear is designed to treat the water quality volume or water quality flow. For flow based design, high flow bypass is internal, for volume based design, high flow bypass is external and prior to pre-detention system. For offline volume based designs the MWS - Linear has the ability to treat the entire water quality volume when used with pre-storage and properly sized.

Non-Corrosive Materials: The MWS – Linear is designed with non-corrosive materials. All internal piping is SD35 PVC. Catch basin filter components, including mounting hardware, fasteners, support brackets, filtration material, and support frame are constructed of non-corrosive materials (316 stainless steel, and UV protected/marine grade fiberglass). Fasteners are stainless steel. Primary filter mesh is 316 stainless steel welded screens. Filtration basket screens for coarse, medium and fine filtration is $\frac{3}{4}$ " x $1\frac{3}{4}$ " expanded, 10 x 10 mesh, and 35 x 35 mesh, respectively. No polypropylene, monofilament netting or fabrics shall be used in this system. Media Protective Panels are constructed of UV protected/marine grade fiberglass. Mounts are constructed of stainless steel. BioMediaGREEN is an inert rock substrate and is non-corrosive. Perimeter filter structure is constructed of lightweight injection molded plastic. Mounting brackets are constructed of SD40 PVC and are mounted with $\frac{3}{8}$ " diameter stainless steel redheads. Drain down filter cover is constructed of UV protected/marine grade fiberglass and stainless steel hinge and mount.

Weight: Each complete unit weighs approximately 29,000 to 40,000 pounds and requires a boom crane to install. Details of this are provided in the installation section of the MWS-Linear Design Kit.

Transportation: The Modular Wetland System – Linear is designed to be transported on a standard flat bed truck. The unit easily fits on a flat bed truck without the need of special permitting.

Alternative Technology Configurations: The Modular Wetland System – Linear is modular in design. Each module will be up to 22 feet long and 5 feet wide. The system can be made in lengths varying from 13 to 100s of feet long. For lengths longer than 22 feet the system will be shipped in modules and assembled on site. The Modular Wetland System – Linear has many alternative configurations. This allows the system to be adapted to many site conditions. Runoff can enter the system through a pipe, and/or a built in curb or grate type opening.

Energy Requirements: The Modular Wetland System – Linear is completely passive and requires no external energy sources.

Buoyancy Issues: Buoyancy is only an issue when ground water levels rise above the bottom of the Modular Wetland System – Linear's concrete structure. With 8.5 cubic yards of wetland media there is no concern of floatation. As a precaution a footing can also be built into the system's concrete structure.

Durability: The structure of the box will be precast concrete. The concrete will be 28 day compressive strength $f_c = 5,000$ psi. Steel reinforcing will be ASTM A – C857. Structure will support an H20 loading as indicated by AASHTO. The joint between the concrete sections will be a lap and joint sealed with ram-nek. Filter (excluding oil absorbent media) and support structures are of proven durability. The filter and mounting structures are of sufficient strength to support water, sediment, and debris loads when the filter is full, with no slippage, breaking, or tearing. All filters are warranted for a minimum of five (5) years.

Oil Absorbent Media: The MWS – Linear utilizes both physical and biological mechanisms to capture and filter oil and grease. A skimmer and boom system will be positioned on the internal perimeter of the catch basin insert. The primary filtration media, BioMediaGreen, utilized in the perimeter and drain down filters, has excellent hydrocarbon removal abilities. Within the wetland filter biological processes capture and

break down oil and grease. Much of the breakdown and transformation of oil and grease is performed by natural occurring bacteria.

Overflow Protection: The grate and curb type MWS – Linear are designed with an internal bypass consisting of two SD PVC pipes which direct high flows around the perimeter and wetland filter, directly into the discharge chamber. For the volume based vault type configuration, bypass should be located prior to the pre-detention system. For peak flows that exceed internal bypass capacity, external bypass is use.

Filter Bypass: Runoff will bypass filtration (BioMediaGREEN and wetland filter) components of the MWS - Linear. The system will still provide screening and settling during higher flow rates for internally bypassed flows. External bypass will bypass of treatment processes.

Pollutant Removal Efficiency: The MWS - Linear is capable of removing over 90% of the net annual total suspended solids (TSS) load based on a 20-micron particle size. Annual TSS removal efficiency models are based on documented removal efficiency performance from full-scale laboratory tests on BioMediaGreen and quarter-scale laboratory tests on the MWS – Linear flow based system.

POLLUTANT	REMOVAL EFFICIENCY
Trash & Litter	99%
TPH (mg/L)	99%
TSS (mg/L)	98%
E. Coli (MPN/100ml)	60%
Turbidity (NTU)	92%
Dissolved Metals (mg/L)	76%

Sil-Co-Sil 106. Mean particle diameter = 19 microns

Non-Scouring: During heavy storm events the runoff bypasses perimeter and wetland filter components. The system will not re-suspend solids at design flows.

Uniqueness: The Modular Wetland System – Linear is a complete self contained treatment train that incorporates capture, screening, sedimentation, filtration, bioretention, high flow bypass, and flow control into a single modular structure. This system provides four stages of treatment making it the only 4 stage treatment train stormwater filtration system, therefore making it unique to the industry. Other systems do not incorporate all the necessary attributes to make it a complete stormwater management device as with the Modular Wetland System – Linear. Therefore, no equal exists for this system.

Pretreatment & Preconditioning: Since the Modular Wetland System – Linear is a complete capture and treatment train stormwater management system no external pretreatment of preconditioning is necessary.

SPECIFICATIONS – BioMediaGREEN

BioMediaGREEN is a proprietary engineered filter media. Made of a unique combination of the inert naturally occurring material this product is non-combustible and do not pose a fire hazard, stable and non-reactive, and is also biodegradable. It is stable with no known adverse environmental effects.

This product has been tested in long-term carcinogenicity studies [inhalation and intraperitoneal injection (i.p.)] with no significant increase in lung tumors or abdominal tumors. Short-term biopersistent (inhalation and intra-tracheal injection) studies have shown that the products disappear very rapidly from the lung.

In October 2001, IARC classified this product as Group 3, "not classifiable as to its carcinogenicity to humans". The 2001 decision was based on the latest epidemiological studies and animal inhalation studies that show no relation between inhalation exposure and the development of tumors.

The product can typically be disposed of in an ordinary landfill (local regulations may apply). If you are unsure of the regulations, contact your local Public Health Department or the local office of the Environmental Protection Agency (EPA).

Coverage: When properly installed BioMediaGREEN Filter Blocks provide sufficient contact time, at rated flows, of passing contaminate water. The BioMediaGREEN material will capture and retain most pollutants that pass through it. The BioMediaGREEN material is made of a proprietary blend of inert substances. The BioMediaGREEN Filter Blocks can be used in different treatment devices, including but not limited to flume filters, trench drain filters, downspout filters, catch basin inserts, water polishing units, and hydrodynamic separators.

Non-Corrosive Materials: The BioMediaGreen material is made of non-corrosive materials.

Durability: The BioMediaGREEN material has been chosen for its proven durability, with an expected life of 2 plus years. The BioMediaGREEN material is of sufficient strength to support water, sediment, and debris loads when the media is at maximum flow; with no slippage, breaking, or tearing. The BioMediaGREEN material has been tested through rigorous flow and loading conditions.

Oil Absorbent Media: The BioMediaGREEN material has been proven to capture and retain hydrocarbons.

Pollutant Removal Efficiency: The BioMediaGREEN Filter Blocks are designed to capture high levels of Hydrocarbons including but not limited to oils & grease, gasoline, diesel, and PAHs. BioMediaGREEN Filter Blocks have the physical ability to block and filter trash and litter, grass and foliage, sediments, TSS, particulate and dissolved metals, nutrients, and bacteria.

BioMediaGREEN technology is based on a proprietary blend of synthetic inert natural substances aimed at removal of various stormwater pollutants. BioMediaGREEN was created to have a very porous structure capable of selectively removing pollutants while

allowing high flow through rates for water. As pollutants are captured by its structure, BioMediaGREEN captures most pollutants and maintains porosity and filtering capabilities.

Field and laboratory tests have confirmed the BioMediaGREEN capability to capture large percentage of TSS, hydrocarbons, nutrients, and heavy metals. Microbial reduction efficiency will vary depending on colony size, flow rates and site specific conditions.

POLLUTANT	REMOVAL EFFICIENCY
Oil & Grease (mg/L)	90%
TPH (mg/L)	99%
TSS (mg/L)	85%
Turbidity (NTU)	99%
Total Phosphorus (mg/L)	69.6%
Dissolved Metals (mg/L)	75.6%

Sil-Co-Sil 106. Mean particle diameter = 19 microns

Replacement: Removal and replacement of the blocks is simple. Remove blocks from filtration system. Replace with new block of equal size.

Maintenance Guidelines for Modular Wetland System - Linear

Maintenance Summary

- Remove Trash from Screening Device – average maintenance interval is 6 to 12 months.
 - *(5 minute average service time).*
- Remove Sediment from Separation Chamber – average maintenance interval is 12 to 24 months.
 - *(10 minute average service time).*
- Replace Cartridge Filter Media – average maintenance interval 12 to 24 months.
 - *(10-15 minute per cartridge average service time).*
- Replace Drain Down Filter Media – average maintenance interval is 12 to 24 months.
 - *(5 minute average service time).*
- Trim Vegetation – average maintenance interval is 6 to 12 months.
 - *(Service time varies).*

System Diagram

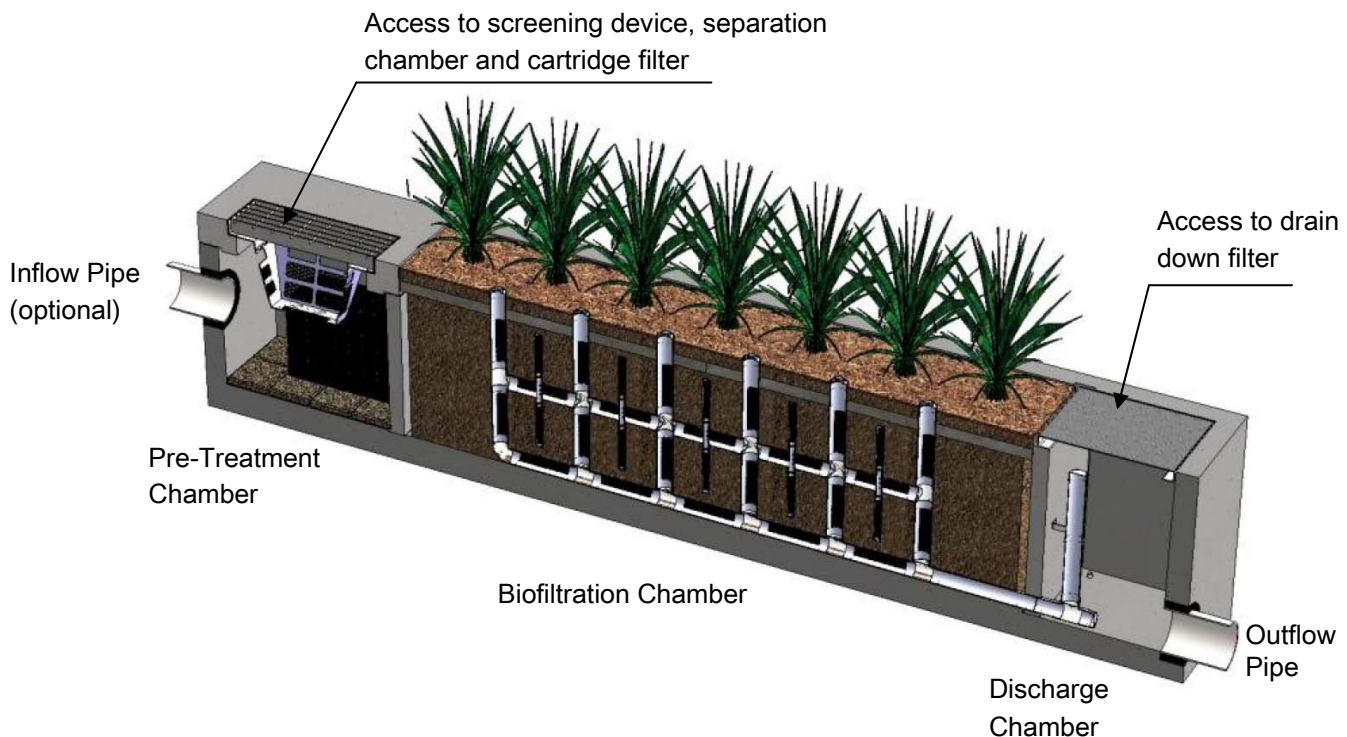

Maintenance Procedures

Screening Device

1. Remove grate or manhole cover to gain access to the screening device in the Pre-Treatment Chamber. Vault type units do not have screening device. Maintenance can be performed without entry.
2. Remove all pollutants collected by the screening device. Removal can be done manually or with the use of a vacuum truck. The hose of the vacuum truck will not damage the screening device.
3. Screening device can easily be removed from the Pre-Treatment Chamber to gain access to separation chamber and media filters below. Replace grate or manhole cover when completed.

Separation Chamber

1. Perform maintenance procedures of screening device listed above before maintaining the separation chamber.
2. With a pressure washer spray down pollutants accumulated on walls and cartridge filters.
3. Vacuum out Separation Chamber and remove all accumulated pollutants. Replace screening device, grate or manhole cover when completed.

Cartridge Filters

1. Perform maintenance procedures on screening device and separation chamber before maintaining cartridge filters.
2. Enter separation chamber.
3. Unscrew the two bolts holding the lid on each cartridge filter and remove lid.
4. Remove each of 4 to 8 media cages holding the media in place.
5. Spray down the cartridge filter to remove any accumulated pollutants.
6. Vacuum out old media and accumulated pollutants.
7. Reinstall media cages and fill with new media from manufacturer or outside supplier. Manufacturer will provide specification of media and sources to purchase.
8. Replace the lid and tighten down bolts. Replace screening device, grate or manhole cover when completed.

Drain Down Filter

1. Remove hatch or manhole cover over discharge chamber and enter chamber.
2. Unlock and lift drain down filter housing and remove old media block. Replace with new media block. Lower drain down filter housing and lock into place.
3. Exit chamber and replace hatch or manhole cover.



Maintenance Notes

1. Following maintenance and/or inspection, it is recommended the maintenance operator prepare a maintenance/inspection record. The record should include any maintenance activities performed, amount and description of debris collected, and condition of the system and its various filter mechanisms.
2. The owner should keep maintenance/inspection record(s) for a minimum of five years from the date of maintenance. These records should be made available to the governing municipality for inspection upon request at any time.
3. Transport all debris, trash, organics and sediments to approved facility for disposal in accordance with local and state requirements.
4. Entry into chambers may require confined space training based on state and local regulations.
5. No fertilizer shall be used in the Biofiltration Chamber.
6. Irrigation should be provided as recommended by manufacturer and/or landscape architect. Amount of irrigation required is dependent on plant species. Some plants may require irrigation.

Maintenance Procedure Illustration

Screening Device

The screening device is located directly under the manhole or grate over the Pre-Treatment Chamber. It's mounted directly underneath for easy access and cleaning. Device can be cleaned by hand or with a vacuum truck.



Separation Chamber

The separation chamber is located directly beneath the screening device. It can be quickly cleaned using a vacuum truck or by hand. A pressure washer is useful to assist in the cleaning process.

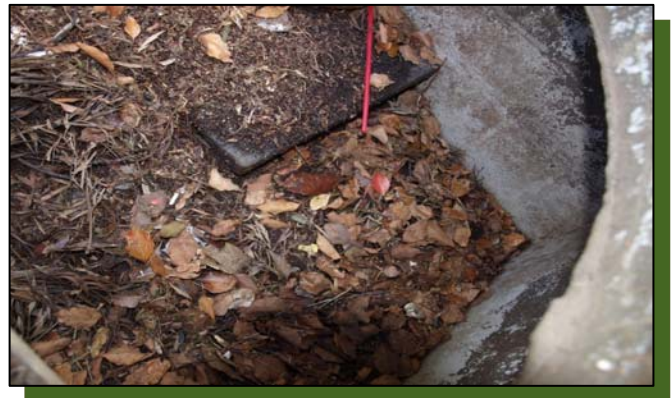

Cartridge Filters

The cartridge filters are located in the Pre-Treatment chamber connected to the wall adjacent to the biofiltration chamber. The cartridges have removable tops to access the individual media filters. Once the cartridge is open media can be easily removed and replaced by hand or a vacuum truck.



Drain Down Filter

The drain down filter is located in the Discharge Chamber. The drain filter unlocks from the wall mount and hinges up. Remove filter block and replace with new block.



Trim Vegetation

Vegetation should be maintained in the same manner as surrounding vegetation and trimmed as needed. No fertilizer shall be used on the plants. Irrigation per the recommendation of the manufacturer and or landscape architect. Different types of vegetation requires different amounts of irrigation.





Inspection Form



Modular Wetland System, Inc.

P. 760.433-7640

F. 760-433-3176

E. Info@modularwetlands.com

www.modularwetlands.com



Inspection Report Modular Wetlands System



Project Name _____

Project Address _____ (city) (Zip Code)

Owner / Management Company _____

Contact _____

Phone () -

Inspector Name _____

Date ____ / ____ / ____

Time _____ AM / PM

Type of Inspection Routine Follow Up Complaint

Storm

Storm Event in Last 72-hours? No Yes

Weather Condition _____

Additional Notes _____

For Office Use Only

(Reviewed By)

(Date)
Office personnel to complete section to the left.

Inspection Checklist

Modular Wetland System Type (Curb, Grate or UG Vault): _____ Size (22', 14' or etc.): _____

Structural Integrity:	Yes	No	Comments
Damage to pre-treatment access cover (manhole cover/grate) or cannot be opened using normal lifting pressure?			
Damage to discharge chamber access cover (manhole cover/grate) or cannot be opened using normal lifting pressure?			
Does the MWS unit show signs of structural deterioration (cracks in the wall, damage to frame)?			
Is the inlet/outlet pipe or drain down pipe damaged or otherwise not functioning properly?			
Working Condition:			
Is there evidence of illicit discharge or excessive oil, grease, or other automobile fluids entering and clogging the unit?			
Is there standing water in inappropriate areas after a dry period?			
Is the filter insert (if applicable) at capacity and/or is there an accumulation of debris/trash on the shelf system?			
Does the depth of sediment/trash/debris suggest a blockage of the inflow pipe, bypass or cartridge filter? If yes, specify which one in the comments section. Note depth of accumulation in in pre-treatment chamber.			Depth:
Does the cartridge filter media need replacement in pre-treatment chamber and/or discharge chamber?			Chamber:
Any signs of improper functioning in the discharge chamber? Note issues in comments section.			
Other Inspection Items:			
Is there an accumulation of sediment/trash/debris in the wetland media (if applicable)?			
Is it evident that the plants are alive and healthy (if applicable)? Please note Plant Information below.			
Is there a septic or foul odor coming from inside the system?			

Waste:	Yes	No
Sediment / Silt / Clay		
Trash / Bags / Bottles		
Green Waste / Leaves / Foliage		

Recommended Maintenance	
No Cleaning Needed	
Schedule Maintenance as Planned	
Needs Immediate Maintenance	

Plant Information	
Damage to Plants	
Plant Replacement	
Plant Trimming	

Additional Notes: _____

Maintenance Report



Modular Wetland System, Inc.

P. 760.433-7640

F. 760-433-3176

E. Info@modularwetlands.com

www.modularwetlands.com



Cleaning and Maintenance Report Modular Wetlands System



Project Name _____

Project Address _____

(city) (Zip Code)

Owner / Management Company _____

Contact _____

Phone () -

Inspector Name _____

Date ____ / ____ / ____ Time ____ AM / PM

Type of Inspection Routine Follow Up Complaint

Storm Storm Event in Last 72-hours? No Yes

Weather Condition _____

Additional Notes _____

For Office Use Only

(Reviewed By)

(Date)
Office personnel to complete section to the left.

Site Map #	GPS Coordinates of Insert	Manufacturer / Description / Sizing	Trash Accumulation	Foliage Accumulation	Sediment Accumulation	Total Debris Accumulation	Condition of Media 25/50/75/100 (will be changed @ 75%)	Operational Per Manufactures' Specifications (If not, why?)
	Lat: Long:	MWS Catch Basins						
		MWS Sedimentation Basin						
		Media Filter Condition						
		Plant Condition						
		Drain Down Media Condition						
		Discharge Chamber Condition						
		Drain Down Pipe Condition						
		Inlet and Outlet Pipe Condition						

Comments:

GEOTECHNICAL INVESTIGATION

**Vivian Street Townhomes
88 Vivian Street
San Rafael, California**

PREPARED FOR:

**ASHTON 3, LLC
5 HOYA STREET
RANCHO MISSION VIEJO, CALIFORNIA 92694**



ASHTON 3

PREPARED BY:

**GEOCON CONSULTANTS, INC.
6671 BRISA STREET
LIVERMORE, CALIFORNIA 94550**



GEOCON

GEOCON PROJECT NO. E9226-04-01

JANUARY 2021



Project No. E9226-04-01
January 22, 2021

Ashton 3, LLC
5 Hoya Street
Rancho Mission Viejo, California 92694

Attention: Mr. Taylor Ashton

Subject: 88 VIVIAN STREET
SAN RAFAEL, CALIFORNIA
GEOTECHNICAL INVESTIGATION

Dear Mr. Ashton:

In accordance with your authorization, we have performed a geotechnical investigation for subject site in San Rafael, California. Our investigation was performed to observe the soil and geologic conditions that may impact site development for the proposed townhome project. The accompanying report presents the results of our investigation and geotechnical conclusions and recommendations. The findings of this study indicate the site is suitable for development as planned provided the recommendations of this report are implemented during design and construction.

If you have any questions regarding this report, or if we may be of further service, please contact the undersigned at your convenience.

Sincerely,

GEOCON CONSULTANTS, INC.

DRAFT

Andre E. Ashour, PE
Senior Project Engineer

DRAFT

Shane Rodacker, GE
Senior Engineer

(1/e-mail) Addressee

TABLE OF CONTENTS

1.	PURPOSE AND SCOPE	1
2.	SITE CONDITIONS AND PROJECT DESCRIPTION	1
3.	GEOLOGIC SETTING	1
4.	GEOLOGIC HAZARDS.....	2
4.1	Faulting and Seismicity	2
4.2	Surface Fault Rupture	3
4.3	Specific Ground Motion Hazard Analysis	3
4.3.1	Site- Specific Shear Wave Velocity.....	3
4.3.2	Probabilistic Seismic Hazard Analysis	4
4.3.3	Deterministic Seismic Hazard Analysis.....	4
4.3.4	Site-Specific Response Spectrum.....	5
4.3.5	Mapped Acceleration Parameters	6
4.3.6	Site-Specific Seismic Design Criteria	6
4.3.7	Site-Specific Peak Ground Acceleration	7
4.4	Liquefaction	7
4.5	Landslides.....	8
4.6	Tsunamis and Seiches	8
5.	SOIL AND GROUNDWATER CONDITIONS.....	8
5.1	Surface Materials	8
5.2	Artificial Fill.....	9
5.3	Bay Mud.....	9
5.4	Older Alluvium.....	9
5.5	Groundwater.....	9
5.6	Soil Corrosion Screening	9
6.	CONCLUSIONS AND RECOMMENDATIONS	11
6.1	General	11
6.2	Soil and Excavation Characteristics	11
6.3	Materials for Fill	11
6.4	Grading	12
6.5	Temporary Excavations	13
6.6	Underground Utilities.....	13
6.7	Post-Tensioned Slabs	14
6.8	Shallow Foundations	15
6.9	Retaining Wall Design	16
6.10	Concrete Slabs-on-Grade	17
6.11	Moisture Protection Considerations.....	18
6.12	Pavement Recommendations.....	18
6.13	Exterior Slabs.....	20
6.14	Surface Drainage.....	20
7.	FURTHER GEOTECHNICAL SERVICES.....	22
7.1	Plan and Specification Review	22
7.2	Testing and Observation Services.....	22

LIMITATIONS AND UNIFORMITY OF CONDITIONS

FIGURES

Figure 1, Vicinity Map

Figure 2, Site Plan

APPENDIX A – FIELD INVESTIGATION

Figure A1, Key to Boring Logs

Figures A2 through A5, Logs of Soil Borings B1 through B4

Figures A6 through A8, Cone Penetrometer Test Profiles – CPT1 through CPT3

APPENDIX B – LABORATORY TESTING

Table B-I, Summary of Laboratory Atterberg Limits Test Results
Table B-II, Summary of Laboratory Expansion Index Test Results
Table B-III, Summary of Laboratory Grain Size Analyses - No. 200 Wash
Table B-IV, Summary of Soil Corrosion Parameters
Figure B1, Consolidation Test Results
Figures B2 and B3, Summary of Laboratory Particle Size Analyses

APPENDIX C – GROUND MOTION HAZARD ANALYSIS

Figure C1, Response Spectrum (Deterministic Analysis & Probabilistic vs. Deterministic)
Figure C2, Design Response Spectrum (Site Specific MCE vs. General Response Spectrum
& Site-Specific Design Response Spectrum)
Figure C3, Response Spectra and Seismic Design Parameters
Figure C4, Shear Velocity Profile (SCPT-1)

APPENDIX D – LIQUEFACTION ANALYSIS

LIST OF REFERENCES

GEOTECHNICAL INVESTIGATION

1. PURPOSE AND SCOPE

This report presents the results of a geotechnical investigation for a proposed townhome development at 88 Vivian Street in San Rafael, California (see Vicinity Map, Figure 1). The purpose of this investigation was to evaluate the subsurface soil and geologic conditions in the areas of the planned development and provide conclusions and recommendations pertaining to the geotechnical aspects of project design and construction, based on the conditions encountered during our study.

The scope of this investigation included field exploration, laboratory testing, engineering analysis and the preparation of this report. Our field exploration consisted of four soil borings drilled on November 19, 2020 to maximum depths of about 25 feet and three Cone Penetrometer Tests (CPTs) advanced on November 10, 2020 to depths ranging from about 82 to about 90 feet below the existing grade. Seismic shear wave velocity measurements were collected from one of the CPTs. The locations of our explorations are depicted on the Site Plan, Figure 2. A detailed discussion of our field investigation, boring logs and CPT profiles are presented in Appendix A.

Laboratory tests were performed on selected soil samples obtained during the investigation to evaluate pertinent physical properties for engineering analyses. In addition, three soil samples were submitted to our laboratory for screening-level corrosion testing. Laboratory test results are presented in Appendix B. Figures related to our site-specific ground motion hazard analysis are presented in Appendix C. Our liquefaction analysis is included as Appendix D.

The opinions expressed herein are based on analysis of the data obtained during the investigation and our experience with similar soil and geologic conditions. References reviewed to prepare this report are provided in the *List of References* section.

If project details vary significantly from those described herein, Geocon should be contacted to determine the necessity for review and possible revision of this report.

2. SITE CONDITIONS AND PROJECT DESCRIPTION

The site is a 2.41-acre parcel (Marin Co. APN 008-092-02) on the southeastern side of Vivian Street. The site is currently occupied by the one- to two-story Country Club Bowl building with at-grade parking in the southwestern portion of the parcel. The site is relatively flat with ground surface elevations of approximately 5 feet above Mean Seal Level (MSL) per web-based mapping. Existing development in the immediate site vicinity generally consists of one- to two-story industrial, multi-family, and commercial buildings.

Based on the site development plan that you provided, we understand that all existing improvements will be razed, and the site will be redeveloped as a 66-unit multifamily residential community. The new residential structures (townhomes) will be up to three stories in height with no subterranean levels. Landscaping, at-grade asphalt parking and driveways, utilities and other improvements necessary for the site development are also expected. Grading plans were not provided; we understand that cuts and fills to attain design subgrade elevation will be minimal.

3. GEOLOGIC SETTING

San Rafael is located within the Coast Ranges Geomorphic Province of California, which is characterized by a series of northwest trending mountains and valleys along the north and central coast of California. Topography

is controlled by the predominant geological structural trends within the Coast Range that generally consist of northwest trending synclines, anticlines and faulted blocks. The dominant structure is a result of both active northwest trending strike-slip faulting, associated with the San Andreas Fault system, and east-west compression within the province.

The San Andreas Fault (SAF) is a major right-lateral strike-slip fault that extends from the Gulf of California in Mexico to Cape Mendocino in northern California. The SAF forms a portion of the boundary between two tectonic plates on the surface of the earth. To the west of the SAF is the Pacific Plate, which moves north relative to the North American Plate, located east of the fault. In the San Francisco Bay Area, movement across this plate boundary is concentrated on the SAF but also distributed, to a lesser extent, across several other faults including the Hayward, Calaveras and Rodgers Creek faults, among others. Together, these faults are referred to as the SAF system.

Basement rock west of the SAF is generally granitic, while to the east it consists of a chaotic mixture of highly deformed marine sedimentary, submarine volcanic and metamorphic rocks of the Franciscan Complex. Both are typically Jurassic to Cretaceous in age (205 to 65 million years old). Overlying the basement rocks are Cretaceous (about 140 to 65 million years old) marine, as well as Tertiary (about 65 to 1.6 million years old) marine and non-marine sedimentary rocks with some continental volcanic rock. These Cretaceous and Tertiary rocks have typically been extensively folded and faulted largely because of movement along the SAF system, which has been ongoing for about the last 25 million years, and regional compression during the last about 4 million years. The inland valleys, as well as the structural depression within which San Francisco Bay is located, are filled with unconsolidated to semi-consolidated deposits of Quaternary age (about the last 1.6 million years). Continental deposits (alluvium) consist of unconsolidated to semi-consolidated sand, silt, clay and gravel, while the bay deposits typically consist of soft organic-rich silt and clay (bay mud) or sand.

Available geologic mapping by the United States Geological Survey (USGS) indicates the site vicinity is in an area of artificial fill over Quaternary-age marine and marsh deposits (Bay Mud).

4. GEOLOGIC HAZARDS

4.1 Faulting and Seismicity

Geologists and seismologists recognize the greater San Francisco Bay Area as one of the most active seismic regions in the United States. The significant earthquakes that occur in the Bay Area are associated with crustal movements along well-defined active fault zones that generally trend in a northwesterly direction.

The San Francisco Bay Area is seismically dominated by the presence of the active San Andreas Fault System. In the theory of plate tectonics, the San Andreas Fault System is a transform fault that forms the boundary between the northward moving Pacific Plate (west of the fault) and the southward moving North American Plate (east of the fault). In the Bay Area, the movement is distributed across a complex system of strike-slip, right lateral parallel and subparallel faults, which include the San Andreas, Hayward and Calaveras Faults, among others.

The table below presents approximate distances to active faults within approximately 25 miles of the site based on web-based mapping by CGS, as previously published by Caltrans. WGS 84 site coordinates are N 37.9634°, W 122.5081°.

**TABLE 4.1
REGIONAL FAULT SUMMARY**

Fault Name	Distance to Site (miles)	Maximum Earthquake Magnitude, M_w
Hayward (North)	7¾	7.3
San Andreas	8¾	8.0
San Gregorio	10¾	7.4
Rodgers Creek	14½	7.3
Contra Costa Shear Zone	19	6.5
West Napa	19½	6.6
Concord	22¾	6.6
Green Valley	24	6.8

The faults tabulated above and numerous other faults in the Bay Area are sources of potential ground motion. However, earthquakes that might occur on other faults within the northern and central California area are also potential generators of significant ground motion and could subject the site to intense ground shaking. The faults and distances tabulated above are intended to acquaint the reader with the seismic setting of the site; this information is not intended to be a basis for our ground motion hazard analysis.

4.2 Surface Fault Rupture

The site is not within a currently established State of California Earthquake Fault Zone for surface fault rupture hazards. No active or potentially-active faults are known to pass directly beneath the site. Therefore, the potential for surface rupture due to faulting occurring beneath the site during the design life of the proposed development is considered low. By definition, an active fault is one with surface displacement within the last 11,000 years. A potentially-active fault has demonstrated evidence of surface displacement with the past 1.6 million years. Faults that have not moved in the last 1.6 million years are typically considered inactive.

4.3 Specific Ground Motion Hazard Analysis

A site-specific ground motion hazard analyses was performed in accordance with ASCE 7-16 Chapter 21 and Section 1613A of the 2019 CBC using online applications developed by USGS.

4.3.1 Site-Specific Shear Wave Velocity

On November 10, 2020, Middle Earth Geo Testing Inc. performed seismic CPT (SCPT) soundings in CPT-1. The SCPT soundings measured the shear waves generated at the ground surface at approximately 5-foot intervals to a depth of about 82 feet below the existing ground surface. The SCPT profile is included herein as Figure C4.

Based on the results of the SCPT, the site-specific soil shear wave velocity for the upper 30 meters feet of soil (V_{s30}) is estimated as 110 meters/second. In accordance with Section 1613A.3.2 of the 2019 California Building Code and Table 20.3-1 of ASCE 7-16, the estimated soil shear wave velocity falls within the boundaries of a Site Class "E".

Although there are liquefiable soils underlying the site, we assume that the proposed townhome structures will have a fundamental period of less than 0.5 seconds and therefore will not require a site-response analysis.

4.3.2 Probabilistic Seismic Hazard Analysis

The risk-targeted Maximum Considered Earthquake (MCER) probabilistic response spectrum consists of the spectral response accelerations which are expected to achieve a 1 percent probability of collapse within a 50-year period, evaluated at 5 percent damping.

The mean spectral response accelerations having a 2 percent chance of exceedance in 50 years were evaluated at 5 percent damping using the USGS Unified Hazard Tool (UHT). The Dynamic U.S. 2014 (v4.2.0) edition was used within the analysis, which is based on the UCERF-3 fault model. The soil underlying the site was modeled as a Site Class “D/E” with a corresponding average shear wave velocity (VS30) of 180 meters per second. The site class definition is based on the SCPT data, which indicates a VS30 of approximately 110 meters per second or Site Class “E”. The lowest VS30 value available in the USGS UHT is Site Class “D/E”; therefore, 180 meters per second value was used for VS30 within the probabilistic analysis.

The web application uses the ground motion prediction equations (GMPEs) from the NGA-West 2 project: Abrahamson-et al. (2014) NGA West 2, Boore et al. (2014) NGA West 2, Campbell-Bozorgnia (2014) NGA West 2, and Chiou-Youngs (2014) NGA West 2. Each GMPE was assigned an equal weight and the mean value of the four GMPEs was evaluated. The mean spectral accelerations were rotated to maximum direction using the period specific ratios from Shahi et al. (2013 & 2014).

The GMPE of Campbell and Borzorgnia requires that the depth to where the shear wave velocity reaches 2.5 kilometers per second (Z2.5) be defined. Additionally, the GMPEs of Abrahamson-et al., Boore et al. and Chiou-Youngs require that the depth to where the shear wave velocity reaches 1 kilometer per second (Z1.0) be defined. The values of Z2.5 and Z1.0 are internally calculated by the Uniform Hazard Tool.

The MCE uniform hazard response spectra was adjusted to risk-targeted spectral accelerations corresponding to a 1 percent chance of collapse in 50 years by using the USGS Risk-Targeted Ground Motion Calculator and following ASCE 7-16 Section 21.2.1.2 Method 2.

The risk-targeted Maximum Considered Earthquake (MCER) probabilistic response spectrum is provided on Figure C1.

4.3.3 Deterministic Seismic Hazard Analysis

In order to define the deterministic scenario events, deaggregation of the uniform hazard probabilistic response spectrum was performed using the USGS UHT. The inversion approach used by UCERF-3 allows for a large number of variations for each source scenario, including multi-fault ruptures. Therefore, deaggregation of UCERF-3 consists of the contributions from multi-fault ruptures rather than individual source contributions. To address this, the UHT aggregates the contributions on a per-fault-section basis, with rupture contributions only ever counted once. The UHT deaggregation contributor list shows the fault sections which contribute most to hazard at a site and report a mean earthquake magnitude for each section identified by a 'parent' fault name and section index. Based on the deaggregation, we have considered scenario events with the greatest contribution to the deterministic ground motions.

The input values used to evaluate the deterministic scenario events are provided in the following table.

**TABLE 4.3.3
INPUT VALUES TO EVALUATE DETERMINISTIC SCENARIO EVENTS**

Parameter	Scenario 1	Scenario 2	Reference
Parent Fault Name	San Andreas (North Coast)	Hayward (North)	
Scenario Name	N. San Andreas: SAO+SAN+SAP+SAS	Hayward: RC+HN+HS+HE	BSSC Online Scenario Catalog
Earthquake Magnitude	8.04	7.58	BSSC Online Scenario Catalog
Fault Mechanism	Strike-Slip	Strike-Slip	
Fault Dip	88.2	76.6	BSSC 2014 ¹
Fault Width	11.8 km	10.58 km	BSSC 2014 ¹
Rake	180	178.2	BSSC 2014 ¹
Z _{TOR}	1.1 km	2.04 km	BSSC 2014 ¹
Rrup	15.90 km	13.09 km	Derived from Rx and Fault Type
Rjb	15.86 km	12.93 km	Derived from Rx and Fault Type
Rx	15.86 km	12.93 km	USGS Quaternary Faults & Folds Database
Vs30	180 m/s	180 m/s	Average Site Class D/E Value
Z _{1.0}	0.038 km	0.038 km	Bay Area Seismic Velocity Model, Release 8.3.0
Z _{2.5}	0.855 km	0.855 km	Bay Area Seismic Velocity Model, Release 8.3.0

1. BSSC 2014, aka. UCERF3_EventSet_All on GitHub

The deterministic median and standard deviation (sigma) for the scenario events were evaluated using the USGS NSHMP-HAZ-WS Response Spectra online application. The deterministic analysis used the same four GMPEs, equally weighted, to generate the median and standard deviation of the ground motion which were then used to calculate the 84th percentile at 5% damping. The geometric median spectral accelerations were rotated to maximum direction using the period specific ratios from Shahi et al. (2013 & 2014).

The deterministic scenarios were compared and a combination of events controls the deterministic spectrum. The fault source resulting in the highest spectral accelerations from 0 to 0.02 seconds would be a magnitude 8.04 event on the San Andreas fault; from 0.03 to 0.4 seconds would be a magnitude 7.58 event on the Hayward fault; and from 0.5 to 10 seconds would be a magnitude 8.04 event on the San Andreas fault.

The largest spectral ordinate of the deterministic spectra was compared to 1.5Fa, with Fa determined using Table 11.4.1. Based on this comparison, a scale factor was applied uniformly across all periods of the deterministic spectrum such that the largest ordinate is not less than 1.5Fa. The scaled 84th percentile maximum rotated component deterministic response spectra is provided on Figure C2.

4.3.4 Site-Specific Response Spectrum

The lesser of the probabilistic and deterministic MCE_R response spectrums is the Site-Specific MCE_R. Two thirds of the Site-Specific MCE_R is the Design Earthquake (DE) Response Spectrum, provided the results are not less

than 80 percent of the modified General Design Response Spectrum determined by ASCE 7-16 Section 11.4.6 with F_a and F_v determined as specified in Section 21.3.

Graphical representations of the analyses are presented on Figures C1 and C2. The Site-Specific Design Earthquake response spectrum at 5 percent damping is presented on graphically on Figure C2 and in tabular form on Figure C3.

4.3.5 Mapped Acceleration Parameters

The following table summarizes the mapped acceleration parameters obtained from the 2019 California Building Code (CBC; Based on the 2018 International Building Code [IBC] and ASCE 7-16), Chapter 16A Structural Design, and Section 1613A Earthquake Loads. The data was calculated using the online application *Seismic Design Maps*, provided by OSHPD. The short spectral response uses a period of 0.2 second.

**TABLE 4.3.5
MAPPED SPECTRAL ACCELERATIONS**

Parameter	Value	2019 CBC Reference
Site Class	E	Section 1613.2.2
MCE _R Ground Motion Spectral Response Acceleration – Class B (short), S_s	1.5g	Figure 1613.2.1(1)
MCE _R Ground Motion Spectral Response Acceleration – Class B (1 sec), S_1	0.6g	Figure 1613.2.1(2)
Site Coefficient, F_a	1.2	Table 1613.2.3(1)
Site Coefficient, F_v	2*	Table 1613.2.3(2)
Site Class Modified MCE _R Spectral Response Acceleration (short), S_{MS}	1.8g	Section 1613.2.3 (Eqn 16-36)
Site Class Modified MCE _R Spectral Response Acceleration – (1 sec), S_{M1}	1.2g*	Section 1613.2.3 (Eqn 16-37)
5% Damped Design Spectral Response Acceleration (short), S_{DS}	1.2g	Section 1613.2.4 (Eqn 16-38)
5% Damped Design Spectral Response Acceleration (1 sec), S_{D1}	0.8g*	Section 1613.2.4 (Eqn 16-39)
T_s	0.67 sec	ASCE 7-16 Chapter 11
<p>Note: *Per Section 11.4.8 of ASCE/SEI 7-16, a ground motion hazard analysis shall be performed for projects for Site Class “E” sites with S_s greater than or equal to 1.0g and for Site Class “D” and “E” sites with S_1 greater than 0.2g. Section 11.4.8 also provides exceptions which indicates that the ground motion hazard analysis may be waived provided the exceptions are followed. Using the code based values presented in the table above, in lieu of a performing a ground motion hazard analysis, requires the exceptions outlined in ASCE 7-16 Section 11.4.8 be followed.</p>		

4.3.6 Site-Specific Seismic Design Criteria

In accordance with the ASCE 7-16 Section 21.4, site-specific design acceleration parameters shall be derived using the results of the site-specific ground motion hazard analysis.

The parameter S_{DS} shall be taken as equal to 90 percent of the maximum spectral acceleration obtained from the site-specific analysis at any period within the range from 0.2 to 5 seconds, inclusive. The parameter S_{D1} shall be taken as the maximum value of the product of the spectral acceleration and period for periods from 1 to 5

seconds, inclusive. The values of S_{MS} and S_{M1} shall be taken as 1.5 times the site-specific values of S_{DS} and S_{D1} . The site-specific design acceleration parameters shall not be less than 80 percent of the general seismic design values determined by ASCE 7-16 Section 11.4.

The following table presents the site-specific seismic design parameters based on the site-specific ground motion hazard analysis.

**TABLE 4.3.6
SITE-SPECIFIC DESIGN ACCELERATION PARAMETERS**

Parameter	Value
Site Class Modified MCER Spectral Response Acceleration (short), S_{MS}	1.440g
Site Class Modified MCER Spectral Response Acceleration - (1 sec), S_{M1}	1.920g
5% Damped Design Spectral Response Acceleration (short), S_{DS}	0.96g
5% Damped Design Spectral Response Acceleration (1 sec), S_{D1}	1.280g

4.3.7 Site-Specific Peak Ground Acceleration

The site-specific Maximum Considered Earthquake (MCE_G) geometric mean peak ground acceleration was evaluated in accordance with ASCE 7-16 Section 21.5.

The probabilistic geometric mean peak ground acceleration and the deterministic 84th percentile geometric mean peak ground acceleration were analyzed using the same approaches as described above. The analysis used the same Site Class and scenario earthquake.

The deterministic MCE_G shall not be less than $0.5F_{PGA}$, where F_{PGA} is determined from ASCE 7-16 Table 11.8-1 with the value of PGA taken as 0.5g. The site-specific MCE_G peak ground acceleration is taken as the lesser of the probabilistic and deterministic MCE_G , provided the value is not less than 80 percent of the value of PGAM as determined by ASCE 7-16 Equation 11.8.1.

**TABLE 4.3.7
ASCE 7-16 SITE-SPECIFIC PEAK GROUND ACCELERATION**

Parameter	Value	ASCE 7-16 Reference
Site-Specific MCE_G Peak Ground Acceleration, PGA_M	0.481g	Section 21.5

4.4 Liquefaction

The site is not currently mapped by the California Geological Survey (CGS) for liquefaction hazards as such mapping has not been performed in the project area; however, web-based mapping by the USGS indicates the entire site possesses a “very high” susceptibility to liquefaction. Liquefaction is a phenomenon in which saturated cohesionless soils are subject to a temporary loss of shear strength due to pore pressure buildup under the cyclic shear stresses associated with intense earthquakes. Primary factors that trigger liquefaction are: moderate to strong ground shaking (seismic source), relatively clean, loose granular soils (primarily poorly graded sands and

silty sands), and saturated soil conditions (shallow groundwater). Due to the increasing overburden pressure with depth, liquefaction of granular soils is generally limited to the upper 50 feet of a soil profile.

We used the computer software program *CLiq* (Version 2.2.0.35, Geologismiki) and the in-situ soil parameters measured in the CPT soundings to evaluate liquefaction potential at the site. The software utilized the 2014 methodology of Boulanger and Idriss (2014) and also considered the potential for dry sand settlements above groundwater. Our evaluation incorporated an earthquake moment magnitude (M_w) of 7.3 (overall all sources) and a groundwater depth of 4 feet. Per 2019 CBC, we used a ground motion (peak ground acceleration) of 0.481g in our analysis.

Liquefaction analyses typically evaluate the potential for liquefaction in soils to depths of 50 feet. As a conservatism, we evaluated liquefaction potential for the full depth of the Bay Mud encountered in our CPTs, based on the geologic recency of those deposits.

Consequences of liquefaction can include ground surface settlement, ground loss (sand boils) and lateral slope displacements (lateral spreading). For liquefaction-induced sand boils or fissures to occur, pore water pressure induced within liquefied strata must exert enough force to break through overlying, non-liquefiable layers. Based on methodology recommended by Youd and Garris (1995), which advanced original research by Ishihara (1985), a capping layer of non-liquefiable soil can prevent the occurrence of sand boils and fissures. Based on the presence of the non-liquefiable layer that mantles the site and the depth to liquefiable layers, the potential for ground loss due to sand boils or fissures in a seismic event is considered low.

The likely consequence of potential liquefaction at the site is settlement. Our analysis indicates that, if liquefaction and cyclic softening were to occur, total ground surface settlements on the order of ½ inch or less may result. Selected output from our liquefaction analysis is presented in Appendix D.

4.5 Landslides

There are no known landslides near the site, nor is the site in the path of any known or potential landslides. We do not consider the potential for a landslide to be a significant hazard to this project.

4.6 Tsunamis and Seiches

Based on mapping published by the California Emergency Management Agency and CGS, the site would not be inundated during an extreme tsunami.

Seiches are large waves generated in enclosed bodies of water in response to ground shaking. No major water-retaining structures are located immediately up gradient from the project site. Flooding from a seismically induced seiche is considered unlikely.

5. SOIL AND GROUNDWATER CONDITIONS

5.1 Surface Materials

Pavement within the project limits generally consists of approximately 2 to 6 inches of asphalt concrete over 5½ to 9 inches of aggregate base materials. Based on visual observations, the existing surface pavements are in poor condition with severe cracking, potholes, and patching.

5.2 Artificial Fill

Below surface materials, artificial fill was encountered in our soil borings and was observed to be variable throughout the project limits to depths ranging from 5½ to 6½ feet below existing surface grades. The fill materials comprise stiff to hard clay (CL) with various amounts of silt, sand and gravel; loose to medium dense clayey sand (SC) with various amounts of silt and gravel; and medium dense gravel (GC/GM) with various amount of sand and clay/silt. The artificial fill materials may differ from those than encountered in our borings. The fills may contain constituents not encountered in our borings or reported herein. Based on our laboratory test results, the clayey soils within the artificial fills possess moderate plasticity and should be considered moderately expansive.

5.3 Bay Mud

Bay Mud deposits were encountered beneath the artificial fills in all our soil borings and CPT locations. As encountered in our CPT soundings, the Bay Mud deposits extend to depths of approximately 42 to 62 feet below existing grade at CPT locations CPT-3 and CPT-1, respectively. As observed in our borings, the deposits consisted of very soft, organic rich fat clay (CH). Our laboratory testing indicates the Bay Mud deposits are highly compressible and weak, consistent with our prior experience and typical Bay Mud properties.

5.4 Older Alluvium

Based on our review of the information obtained in our CPT soundings, it appears soil conditions at the site transition from Bay Mud to an older alluvial deposit extend to depths of approximately 82 to 90 feet below the existing surface grades at CPT location CPT-1 and CPT-3, respectively– the maximum depths extended. The soil types within this alluvial unit were not directly observed due to our CPT-based field exploration.

5.5 Groundwater

Groundwater was encountered at depths of approximately 4 to 5 feet in our borings at the time drilling. Actual groundwater levels will fluctuate with variations in rainfall, temperature and other factors and may be higher or lower than observed during our study. Additionally, it is not uncommon for perched groundwater conditions to develop where none previously existed, especially in or atop fine-grained soils that are subjected to irrigation or precipitation.

5.6 Soil Corrosion Screening

Soil samples obtained during our field exploration were subjected to laboratory testing for minimum resistivity, pH, and chloride and water-soluble sulfate. The laboratory test results and published screening levels are presented in Appendix B. Soil corrosivity should be considered in the design of buried metal pipes, underground structures, etc.

Water-soluble sulfate test results on selected samples of site soils indicate an SO exposure classification for sulfate attack on normal portland cement concrete (PCC) as defined in Chapter 318, Table 19.3.1.1 of the ACI Building Code Requirements for Structural Concrete. ACI does not set forth requirements for SO sulfate exposure classification. In addition, none of the two soil samples tested would be classified as corrosive to buried metal improvements based on Caltrans criteria.

Geocon does not practice in the field of corrosion engineering and mitigation. If corrosion sensitive improvements are planned, it is recommended that a corrosion engineer be retained to evaluate corrosion test results and

incorporate the necessary precautions to avoid premature corrosion of buried metal pipes and concrete structures in direct contact with the soils.

6. CONCLUSIONS AND RECOMMENDATIONS

6.1 General

- 6.1.1 No overriding geotechnical constraints were encountered during our investigation that would preclude the project as presently proposed. Primary geotechnical considerations are the presence of highly compressible Bay Mud deposits within the upper approximately 42 to 62 feet below existing grade and the potential for strong seismic shaking. A layer of lightweight fill material will be required below the proposed townhomes to mitigate settlement from building loads.
- 6.1.2 Based on the subsurface conditions at the site and the anticipated structural loading, post-tension foundation systems, used in conjunction with the remedial grading described herein, can be used to support the planned townhome buildings. Post-construction settlements due to static foundation loads should in order of 1¾ inch or less with differential settlements of 1 inch or less across a horizontal distance of 50 feet.
- 6.1.3 Any changes in the design, location or elevation, as outlined in this report, should be reviewed by this office. Geocon should be contacted to determine the necessity for review and possible revision of this report.
- 6.1.4 The proposed project redevelops a site with past episodes of grading and construction. As such, unknown underground improvements and areas of undocumented fill materials (not discussed herein) may be present. If encountered, supplemental recommendations will be provided during site development.
- 6.1.5 All references to relative compaction and optimum moisture content in this report are based on the latest edition of ASTM D 1557.

6.2 Soil and Excavation Characteristics

- 6.2.1 Based on the soils conditions encountered in our field explorations, we anticipate the onsite soils can be excavated with moderate effort using conventional excavation equipment. We do not anticipate excavations at the site will generate oversize material (greater than 6 inches in nominal dimension). Any artificial fills encountered at the site are undocumented and may contain constituents not reported herein.
- 6.2.2 It is the responsibility of the contractor to ensure that all excavations and trenches are properly shored and maintained in accordance with applicable Occupation Safety and Health Administration (OSHA) rules and regulations to maintain safety and maintain the stability of adjacent existing improvements.
- 6.2.3 The existing soils encountered at the site should be considered “expansive” as defined by 2019 CBC. However, the recommendations of this report assume proposed building foundation systems will derive support in properly compacted non expansive fills (i.e., lightweight fill).

6.3 Materials for Fill

- 6.3.1 Excavated soils generated from cut operations at the site should be suitable for use as engineered fill in structural areas provided, they do not contain deleterious matter, organic material, or cementations larger than 6 inches in maximum dimension.

- 6.3.2 Import fill material should be primarily granular with a “low” expansion potential (Expansion Index less than 50), a Plasticity Index less than 15, be free of organic material and construction debris, and not contain rock larger than 6 inches in greatest dimension.
- 6.3.3 Lightweight fill (LWF), where required, should have maximum unit weight of 30 pounds per cubic foot (pcf). LWF materials include, but are not limited to, foamed concrete or expanded polystyrene (EPS), low-density cellular concrete (LDCC), and lightweight aggregate (LWA). In our experience, LDCC is the most common of the listed LWF materials.
- 6.3.4 Environmental characteristics and corrosion potential of import soil materials may also be considered. Proposed import materials should be sampled, tested, and approved by Geocon prior to transportation to the site.

6.4 Grading

- 6.4.1 All clearing operations and earthwork (including over-excavation, scarification, and recompaction) should be observed and all fills tested for recommended compaction and moisture content by representatives of Geocon.
- 6.4.2 Structural areas should be considered as areas extending a minimum of 5 feet horizontally from a foundation or beyond the outside dimensions of buildings, including footings and overhangs carrying structural loads, and where not restricted by property boundaries.
- 6.4.3 A preconstruction conference should be held at the site prior to the beginning of grading operations with the owner, contractor, civil engineer and geotechnical engineer in attendance. Special soil handling requirements can be discussed at that time.
- 6.4.4 Site preparation should begin with removal of any surface and subsurface structures including all foundations, flatwork, and pavement. Within landscaped area, all surface vegetation should be stripped and all the trees, root balls and shrubs should be removed such that no roots larger than approximately 1 inch in diameter remain within proposed building footprints. All active or inactive utilities within the construction area should be protected, relocated, or abandoned. Any pipelines to be abandoned that are greater than 2 inches and less than 18 inches in diameter should be removed or filled with sand-cement slurry. Utilities larger than 18 inches in diameter should be removed. Excavations or depressions resulting from site clearing operations, or other existing excavations or depressions, should be restored with engineered fill in accordance with the recommendations of this report.
- 6.4.5 After demolition and the removal of existing improvements, the existing subgrade within building pad areas should be over-excavated to a depth of 3 feet below the existing surface grade or two feet below proposed pad grade, whichever is deeper, and replaced with LWF meeting the requirements of Section 6.3.3. The exposed subgrade should be scarified to a depth of 8 to 12 inches, moisture conditioned to at least 2% above optimum and compacted to at least 90% relative compaction before placing LWF.
- 6.4.6 The existing soils outside of building pad areas should be over-excavated to a depth of approximately 1 foot. The exposed bottom should be scarified 8 to 12 inches, moisture conditioned to at least 2% above optimum moisture and recompacted to at least 90% relative compaction (at near optimum moisture where fill materials are predominantly sands or gravels).

- 6.4.7 The exposed bottom surfaces and bottom processing should be observed by our representatives on a full-time basis. Supplemental recommendations may be provided based on-site conditions during grading. Deeper over-excavations may be needed in some areas.
- 6.4.8 If grading commences in winter or spring, or in periods of precipitation, excavated and in-place soils may be wet. Earthwork contractors should be aware of potential compaction/workability difficulties. The most effective site preparation alternatives will depend on site conditions prior to and during grading operations; we should evaluate site conditions at those times and provide supplemental recommendations, if necessary.
- 6.4.9 All engineered fills should be placed in layers no thicker than will allow for adequate bonding and compaction (typically 8 inches). Fill soils should be placed, moisture conditioned to minimum 2 percent above optimum moisture content (near optimum moisture where fill materials are predominantly sands or gravels) and compacted to at least 90% relative compaction.

6.5 Temporary Excavations

- 6.5.1 We anticipate that the majority of the site will be classified as Cal-OSHA "Type C" soil when encountered in excavations during site development and construction. Excavation sloping, benching, the use of trench shields, and the placement of trench spoils should conform to the latest applicable Cal-OSHA standards. The contractor should have a Cal-OSHA-approved "competent person" onsite during excavation to evaluate trench conditions and make appropriate recommendations where necessary.
- 6.5.2 All onsite excavations must be conducted in such a manner that potential surcharges from existing structures, construction equipment, and vehicle loads are resisted. The surcharge area may be defined by a 1:1 projection down and away from the bottom of an existing foundation or vehicle load. Penetrations below this 1:1 projection will require special excavation measures such as sloping and possibly shoring.
- 6.5.3 It is the contractor's responsibility to provide sufficient and safe excavation support as well as protecting nearby utilities, structures, and other improvements that may be damaged by earth movements.
- 6.5.4 Temporary excavations such as utility trench sidewalls within the dune sands should remain near vertical to depths of at least 3 feet below ground surface, although some sloughing and caving may occur, particularly if clean sandy or gravelly soils, undocumented fills or groundwater are encountered. Excavations greater than approximately 3 feet in height or those that are surcharged by adjacent traffic or structures may require sloping or shoring measures in order to provide a stable excavation.
- 6.5.5 Temporary excavations should be protected from rainfall and erosion. Surface runoff should be directed away from excavations or slopes.

6.6 Underground Utilities

- 6.6.1 Underground utility trenches should be backfilled with properly compacted material. The material excavated from the trenches should be adequate for use as backfill provided it does not contain deleterious matter, vegetation or rock larger than six inches in maximum dimension. Trench backfill should be placed in loose lifts not exceeding eight inches and compacted to at least 90% relative compaction to minimum 2 percent above optimum moisture content.

6.6.2 Bedding and pipe zone backfill typically extends from the bottom of the trench excavations to a minimum of six inches above the crown of the pipe. Pipe bedding material should consist of crushed aggregate, clean sand or similar open-graded material. Proposed bedding and pipe zone materials should be reviewed by Geocon prior to construction; materials such as ¾-inch drain rock may require wrapping with filter fabric to mitigate the potential for piping. Bedding and backfill should also conform to the requirements of the governing utility agency.

6.7 Post-Tensioned Slabs

6.7.1 We understand that thickened post-tensioned slabs in engineered fill may be used in slab-on-grade areas for the new apartment buildings. Post-tensioned (PT) slab thickness, reinforcement and crack control spacing should be designed by the project structural engineer. PT slabs should be designed to accommodate the estimated settlements discussed in Section 6.1.2.

6.7.2 PT slab contact pressure should be generally limited to 350 psf for dead plus live loads. We recognize that isolated areas of higher contact pressure may exist at wall or column locations. When available, PT slab contact pressures should be reviewed by Geocon to confirm the settlement estimates provided herein. Supplemental recommendations may be provided after our review.

6.7.3 We anticipate post-tensioned slabs will be designed using a modulus of subgrade reaction. We recommended that a modulus of subgrade reaction of 120 pounds per cubic inch (pci) be utilized. The modulus of subgrade reaction is based on the square-foot plate load method and should be adjusted as needed to account for slab size. The modulus should be reduced in accordance with the following equation:

$$K_R = K \left[\frac{B + 1}{2B} \right]^2$$

Where: K_R = reduced subgrade modulus

K = unit subgrade modulus

B = foundation width in feet

If applicable, the reduced modulus of subgrade reaction value calculated above should be adjusted to account for the rectangularity of the mat foundation per the following:

$$K_R = \frac{K_{(B \times B)} \left(1 + \frac{B}{2L} \right)}{1.5}$$

Where: K_R = reduced subgrade modulus

$K_{(B \times B)}$ = subgrade modulus scaled for square mat size

B = mat foundation width in feet

L = mat foundation length in feet

6.7.1 Mat foundation design will require iteration(s) between the geotechnical engineer and structural engineers to review the estimated settlement and foundation contact pressures. Differential settlement will be controlled by mat rigidity.

- 6.7.4 Post-tensioned foundations should be embedded in accordance with the recommendations of the structural engineer. If a post-tensioned mat foundation system is planned, the slab should possess a thickened edge with a minimum width of 12 inches. The thickened edge should extend below the crushed rock underlayment layer.
- 6.7.5 The thickness of post-tensioned foundation systems should be determined by the project structural engineer. Based on our experience with similar projects and soils conditions, we anticipate the post-tensioned slab thicknesses will be on the order of 10 to 12 inches.
- 6.7.6 Our experience indicates that post-tensioned slabs are susceptible to excessive edge lift, regardless of the underlying soil conditions. Placing reinforcing steel at the bottom of the perimeter footings and the interior stiffener beams may mitigate this potential. Because of the placement of the reinforcing tendons in the top of the slab, the resulting eccentricity after tensioning reduces the ability of the system to mitigate edge lift. The structural engineer should design the foundation system to reduce the potential of edge lift occurring for the proposed structures.
- 6.7.7 During the construction of the post-tension foundation system, the concrete should be placed monolithically. Under no circumstances should cold joints be allowed to form between the footings/grade beams and the slab during the construction of the post-tension foundation system.
- 6.7.8 The use of isolated footings, which are located beyond the perimeter of the building and support structural elements connected to the building, are not recommended. Where this condition cannot be avoided, the isolated footings should be connected and tied to the building foundation system with grade beams.
- 6.7.9 Consideration should be given to connecting patio slabs to the building foundation to reduce the potential for future separation to occur.
- 6.7.10 Post-tensioned slabs should be underlain by at least 3 inches of ½-inch or ¾-inch crushed rock with no more than 5 percent passing the No. 200 sieve to serve as a capillary break.
- 6.7.11 Where post-tensioned foundation systems are designed and constructed as recommended herein, post-construction settlement due to dead + live loads should be approximately 1¾ inch or less with differential settlements of less than 1 inch across a horizontal distance of 50 feet.

6.8 Shallow Foundations

- 6.8.1 Shallow foundations (footings) founded in engineered fill may be used for ancillary site structures such as short retaining walls, screen walls, or trash enclosures. The following recommendations are based on the assumption that the soils within 4 feet of finish grade will consist of moderate expansive materials.
- 6.8.2 It is recommended that conventional shallow footings have a minimum embedment depth of 12 inches below lowest adjacent pad grade. Strip footings should be at least 12 inches wide. Spread column footings should be at least 3 feet square.
- 6.8.3 Footings proportioned as recommended may be designed for an allowable soil bearing pressure of 2,000 pounds per square foot (psf). The allowable bearing pressure is for dead + live loads and may be increased by up to one-third for transient loads due to wind or seismic forces.

- 6.8.4 The allowable passive pressure used to resist lateral movement may be assumed to be equal to a fluid weighing 300 pounds per cubic foot (pcf) for footings poured neat against properly compacted fills or undisturbed natural soils. The allowable passive pressure assumes a horizontal surface extending at least 5 feet or 3 times the surface generating the passive pressure, whichever is greater. The allowable coefficient of friction to resist sliding is 0.30 for concrete against soil. Combined passive resistance and friction may be utilized for design provided that the frictional resistance is reduced by 50%. Where not protected by flatwork or pavement, the upper 1 foot of soil should be neglected when calculating passive resistance to lateral loads.
- 6.8.5 Minimum reinforcement for continuous footings should consist of four No. 4 steel reinforcing bars; two placed near the top of the footing and two near the bottom. Spread column footing reinforcement should be specified by the structural engineer.
- 6.8.6 The foundation dimensions and minimum reinforcement recommendations presented herein are based upon soil conditions only and are not intended to be used in lieu of those required for structural purposes.
- 6.8.7 Underground utilities running parallel to footings should not be constructed in the zone of influence of footings. The zone of influence may be taken to be the area beneath the footing and within a 1:1 (horizontal:vertical) plane extending out and down from the bottom edge of the footing.
- 6.8.8 The use of isolated footings that are located beyond the perimeter of the building and support structural elements connected to the building are not recommended. Where this condition cannot be avoided, the isolated footings should be connected and tied to the building foundation system with grade beams.
- 6.8.9 The foundation subgrade should be sprinkled as necessary to maintain a moist condition without significant shrinkage cracks as would be expected in any concrete placement. Our representative should observe all footing excavations prior to placing reinforcing steel.

6.9 Retaining Wall Design

- 6.9.1 Lateral earth pressures may be used in the design of retaining walls and buried structures. Lateral earth pressures against these facilities may be assumed to be equal to the pressure exerted by an equivalent fluid. The unit weight of the equivalent fluid depends on the design conditions. Table 6.9 summarizes the weights of the equivalent fluid based on the different design conditions.

**TABLE 6.9
RECOMMENDED LATERAL EARTH PRESSURES**

Condition	Equivalent Fluid Density
Active	50 pcf
At-Rest	65 pcf

- 6.9.2 Unrestrained walls should be designed using the active case. Unrestrained walls are those that are allowed to rotate more than 0.01H (where H is the height of the wall). Walls restrained from movement such as basement walls should be designed using the at-rest case. The above soil pressures assume

level backfill under drained conditions within an area bounded by the wall and a 1:1 plane extending upward from the base of the wall and no surcharges within that same area.

6.9.3 Retaining wall foundations should be designed as continuous strip footings in accordance with Section 6.8.

6.9.4 Unless hydrostatic conditions are incorporated into design, retaining walls greater than 2 feet tall (retained height) should be provided with a drainage system adequate to prevent the buildup of hydrostatic forces and should be waterproofed as required by the project architect. Positive drainage for retaining walls should consist of a vertical layer of permeable material positioned between the retaining wall and the soil backfill. The permeable material may be composed of a composite drainage geosynthetic or a natural permeable material such as crushed gravel at least 12 inches thick and capped with at least 12 inches of native soil. A geosynthetic filter fabric should be placed between the gravel and the soil backfill. Provisions for removal of collected water should be provided for either system by installing a perforated drainage pipe along the bottom of the permeable material that leads to suitable drainage facilities.

6.10 Concrete Slabs-on-Grade

6.10.1 Concrete slabs-on-grade subject to vehicular loading are pavements should be designed in accordance with the recommendations in Section 6.12 of this report.

6.10.2 Concrete slabs-on-grade for structures should be a minimum of 4 inches thick and minimum slab reinforcement should consist of No. 3 steel reinforcing bars placed 24 inches on center in both horizontal directions. Steel reinforcing should be positioned vertically near the slab midpoint.

6.10.3 Interior slabs should also be underlain by 3 inches of ½-inch or ¾-inch crushed rock with no more than 5 percent passing the No. 200 sieve to serve as a capillary break. The crushed rock should be subjected to several passes with a walk-behind vibratory compactor or similar equipment prior to placing a vapor barrier or rebar for the slab-on-grade.

6.10.4 The slab-on-grade dimensions and minimum reinforcement recommendations presented herein are based upon soil conditions only and are not intended to be used in lieu of those required for structural purposes.

6.10.5 Crack control joints for slabs-on-grade should be spaced at intervals not greater than 8 feet and should be constructed using saw-cuts or other methods as soon as practical following concrete placement. Crack control joints should extend a minimum depth of one-fourth the slab thickness. Construction joints should be designed by the project structural engineer.

6.10.6 The recommendations of this report are intended to reduce the potential for cracking of slabs due to soil movement. However, even with the incorporation of the recommendations presented herein, foundations, stucco walls, and slabs-on-grade may exhibit some cracking due to soil movement. The occurrence of concrete shrinkage cracks is independent of the supporting soil characteristics. Their occurrence may be reduced and/or controlled by limiting the slump of the concrete, proper concrete placement and curing, and by the placement of crack control joints at periodic intervals, in particular, where re-entrant slab corners occur.

6.11 Moisture Protection Considerations

- 6.11.1 A vapor barrier is not required beneath slabs-on-grade (including post-tensioned slabs) for geotechnical purposes. Further, the migration of moisture through concrete slabs or moisture otherwise released from slabs is not a geotechnical issue. However, for the convenience of the owner, we are providing the following general suggestions for consideration by the owner, architect, structural engineer, and contractor. The suggested procedures may reduce the potential for moisture-related floor covering failures on concrete slabs-on-grade, but moisture problems may still occur even if the procedures are followed. If more detailed recommendations are desired, we recommend consulting a specialist in this field. If a vapor barrier is used beneath mat slab foundations, we should review the geotechnical design parameters presented herein.
- 6.11.2 A vapor barrier meeting ASTM E 1745-09 Class C requirements may be placed directly below the slab, without a sand cushion. To reduce the potential for punctures, a higher quality vapor barrier (15 mil, Class A or B) should be used. The vapor barrier, if used, should extend to the edges of the slab, and should be sealed at all seams and penetrations.
- 6.11.3 The concrete water/cement ratio should be as low as possible. The water/cement ratio should not exceed 0.45 for concrete placed directly on the vapor barrier. Midrange plasticizers could be used to facilitate concrete placement and workability.
- 6.11.4 Proper finishing, curing, and moisture vapor emission testing should be performed in accordance with the latest guidelines provided by the American Concrete Institute, Portland Cement Association, and ASTM.

6.12 Pavement Recommendations

- 6.12.1 The upper 12 inches of pavement subgrade should be scarified, moisture conditioned to minimum 2 percent above optimum moisture content (at near optimum moisture where fill materials are predominantly sands or gravels) and compacted to at least 95% relative compaction. Prior to placing aggregate base, the finished subgrade should be proof-rolled with a laden water truck (or similar equipment with high contact pressure) to verify stability.
- 6.12.2 Sidewalk, curb and gutter, and driveway encroachments should be designed and constructed in accordance with City of San Rafael requirements, as applicable.
- 6.12.3 We recommend the following asphalt concrete (AC) pavement sections for design to establish subgrade elevations in pavement areas. The project civil engineer should determine the appropriate Traffic Index (TI) based on anticipated traffic conditions. The flexible pavement sections below are based on estimated design TIs and an R-Value of 5 for the subgrade soils. We can provide additional sections based on other TIs if necessary.

**TABLE 6.12.3
FLEXIBLE PAVEMENT SECTION RECOMMENDATIONS**

Location	Estimated Traffic Index (TI)	AC Thickness (Inches)	AB Thickness (Inches)
Parking Stalls	4.5	3	8
Driveways	6.0	3½	12½
Heavy-Duty	7.0	4	15½

Note: The recommended flexible pavement sections are based on the following assumptions:

1. AB: Class 2 AB with a minimum R-Value of 78 and meeting the requirements of Section 26 of the latest Caltrans Standard Specifications.
2. AB is compacted to 95% or higher relative compaction at or near optimum moisture content. Prior to placing AB, the subgrade should be proof-rolled with a loaded water truck to verify stability.
3. AC: Asphalt concrete conforming to local agency standards or Section 39 of the latest Caltrans Standard Specifications.

6.12.4 The AC sections in Table 6.12.3 are final, minimum thicknesses. If staged pavements are used, the construction bottom AC lift should be at least 2 inches thick. Following construction, the finish top AC lift should be at least 1.5 inches thick.

6.12.5 Unless specifically designed and evaluated by the project structural engineer, where concrete paving will be utilized for support of vehicles, we recommend the concrete be a minimum of 6 inches thick and reinforced with No. 3 steel reinforcing bars placed 24 inches on center in both horizontal directions. In addition, doweling, reinforcing steel or other load-transfer mechanism should be provided at joints if desired to reduce the potential for vertical offset. The concrete should have a minimum 28-day compressive strength of 3,500 psi.

6.12.6 We recommend that at least 6 inches of Class 2 Aggregate Base (Class 2 AB) be used below rigid concrete pavements. The aggregate base should be compacted to at least 95% relative compaction near optimum moisture content.

6.12.7 In general, we recommend that concrete pavements be designed, constructed and maintained in accordance with industry standards such as those provided by the American Concrete Pavement Association.

6.12.8 The performance of pavements is highly dependent upon providing positive surface drainage away from the edge of pavements. Ponding of water on or adjacent to the pavement will likely result in saturation of the subgrade materials and subsequent cracking, subsidence and pavement distress. If planters are planned adjacent to paving, it is recommended that the perimeter curb be extended at least 6 inches below the bottom of the aggregate base to minimize the introduction of water beneath the paving. Alternatives such as plastic moisture cut-offs or modified drop-inlets may also be considered in lieu of deepened curbs.

6.12.9 Asphalt pavement section recommendations for driveways and parking areas are based on Caltrans design procedures. It should be noted that most rational pavement design procedures are based on projected street or highway traffic conditions and, hence, may not be representative of vehicular loading that occurs in parking lots and driveways. Pavement proximity to landscape irrigation, reduced traffic speed and short turning radii increase the potential for pavement distress to occur in parking

lots even though the volume of traffic is significantly less than that of an adjacent street. The Caltrans *Highway Design Manual* indicates that the resulting pavement sections for parking lots are minimized to keep initial costs down but are reasonable because additional AC surfacing can be added later, if needed, and generally without incurring traffic hazards or traffic handling problems. It is generally not economically feasible to design and construct the entire parking lot and driveways for the unique loading conditions previously described. Periodic maintenance of the pavement in these areas, therefore, should be anticipated.

- 6.12.10 We recommend that all retaining wall designs be reviewed by Geocon to confirm the incorporation of the recommendations provided herein. In particular, potential surcharges from adjacent structures and other improvements should be reviewed by Geocon.

6.13 Exterior Slabs

- 6.13.1 Exterior slabs, not subject to traffic loads, should be at least 4 inches thick and reinforced with No. 3 steel reinforcing bars placed 18 inches on center in both horizontal directions, positioned near the slab midpoint. We recommend that at least 6 inches of Class 2 Aggregate Base (AB) compacted to at least 95% relative compaction be used below exterior concrete slabs. Prior to placing AB, the subgrade should be scarified 8 inches, moisture conditioned 2% above optimum and properly compacted to at least 90% relative compaction (at near optimum moisture where fill materials are predominantly sands or gravels).
- 6.13.2 The slab-on-grade dimensions and minimum reinforcement recommendations presented herein are based upon soil conditions only and are not intended to be used in lieu of those required for structural purposes.
- 6.13.3 Crack control joints for slabs-on-grade should be spaced at intervals not greater than 8 feet for 4-inch slabs and should be constructed using saw-cuts or other methods as soon as practical following concrete placement. Crack control joints should extend a minimum depth of one-fourth the slab thickness. Construction joints should be designed by the project structural engineer.
- 6.13.4 The recommendations of this report are intended to reduce the potential for cracking of slabs due to soil movement. However, even with the incorporation of the recommendations presented herein, foundations, stucco walls, and slabs-on-grade may exhibit some cracking due to soil movement. This is common for project areas that contain expansive soils since designing to eliminate potential soil movement is cost prohibitive. The occurrence of concrete shrinkage cracks is independent of the supporting soil characteristics. Their occurrence may be reduced and/or controlled by limiting the slump of the concrete, proper concrete placement and curing, and by the placement of crack control joints at periodic intervals, in particular, where re-entrant slab corners occur.

6.14 Surface Drainage

- 6.14.1 Proper surface drainage is critical to the future performance of the project. Uncontrolled infiltration of irrigation excess and storm runoff into the soils can adversely affect the performance of the planned improvements. Saturation of a soil can cause it to lose internal shear strength and increase its compressibility, resulting in a change to important engineering properties. Proper drainage should be maintained at all times.
- 6.14.2 All site drainage should be collected and transferred to the street in non-erosive drainage devices. Drainage should not be allowed to pond anywhere on the site, and especially not against any

foundations or retaining walls. Drainage should not be allowed to flow uncontrolled over any descending slope. The proposed structures should be provided with roof gutters. Discharge from downspouts, roof drains and scuppers not permitted onto unprotected soils within five feet of the building perimeter. Planters which are located adjacent to foundations should be sealed or properly drained to prevent moisture intrusion into the materials providing foundation support. Landscape irrigation within five feet of the building perimeter footings should be kept to a minimum to just support vegetative life.

6.14.3 Positive site drainage should be provided away from structures, pavement, and the tops of slopes to swales or other controlled drainage structures. The building pad and pavement areas should be fine graded such that water is not allowed to pond. Final soil grade should slope a minimum of 2% away from structures.

6.14.4 We recommend implemented measures to reduce infiltrating surface water near buildings and slabs-on-grade. Such measures may include:

- Selecting drought-tolerant plants that require little or no irrigation, especially within 3 feet of buildings, slabs-on-grade, or pavements.
- Using drip irrigation or low-output sprinklers.
- Using automatic timers for irrigation systems.
- Appropriately spaced area drains.
- Hard-piping roof downspouts to appropriate collection facilities.

7. FURTHER GEOTECHNICAL SERVICES

7.1 Plan and Specification Review

- 7.1.1 We should review project plans and specifications prior to final design submittal to assess whether our recommendations have been properly implemented and evaluate if additional analysis and/or recommendations are required.

7.2 Testing and Observation Services

- 7.2.1 The recommendations provided in this report are based on the assumption that we will continue as Geotechnical Engineer of Record throughout the construction phase and provide compaction testing and observation services and foundation observations throughout the project. It is important to maintain continuity of geotechnical interpretation and confirm that field conditions encountered are similar to those anticipated during design. If we are not retained for these services, we cannot assume any responsibility for others interpretation of our recommendations, and therefore the future performance of the project.

LIMITATIONS AND UNIFORMITY OF CONDITIONS

The recommendations of this report pertain only to the site investigated and are based upon the assumption that the soil conditions do not deviate from those disclosed in the investigation. If any variations or undesirable conditions are encountered during construction, or if the proposed construction will differ from that anticipated herein, Geocon Consultants, Inc. should be notified so that supplemental recommendations can be given. The evaluation or identification of the potential presence of hazardous or corrosive materials was not part of the geotechnical scope of services provided by Geocon Consultants, Inc.

This report is issued with the understanding that it is the responsibility of the owner, or of his representative, to ensure that the information and recommendations contained herein are brought to the attention of the architect and engineer for the project and incorporated into the plans, and the necessary steps are taken to see that the contractor and subcontractors carry out such recommendations in the field.

The findings of this report are valid as of the present date. However, changes in the conditions of a property can occur with the passage of time, whether they are due to natural processes or the works of man on this or adjacent properties. In addition, changes in applicable or appropriate standards may occur, whether they result from legislation or the broadening of knowledge. Accordingly, the findings of this report may be invalidated wholly or partially by changes outside our control. Therefore, this report is subject to review and should not be relied upon after a period of three years.

Our professional services were performed, our findings obtained, and our recommendations prepared in accordance with generally accepted geotechnical engineering principles and practices used in the site area at this time. No warranty is provided, express or implied.



 GEOCON CONSULTANTS, INC. <small>6671 BRISA STREET - LIVERMORE, CA 94550 PHONE 925.371.5900 - FAX 925.371.5915</small>		
Vivian Street Townhomes		
88 Vivian Street San Rafael, California		
VICINITY MAP		
E9226-04-01	January 2021	Figure 1



LEGEND:

- B5** ⊗ Approximate Boring Location
- CPT-3** ⊙ Approximate CPT Location



GEOCON
CONSULTANTS, INC.

6671 BRISA STREET - LIVERMORE, CA 94550
PHONE 925.371.5900 - FAX 925.371.5915

Vivian Street Townhomes

88 Vivian Street
San Rafael, California

SITE PLAN

E9226-04-01

January 2021

Figure 2

APPENDIX

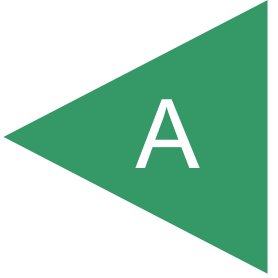

APPENDIX A FIELD EXPLORATION

Fieldwork for our investigation included a site visit, subsurface exploration, and soil sampling. The locations of our exploratory borings and CPTs are shown on the Site Development Plan, Figure 2. Soil boring logs and CPT profiles for our exploration are presented as figures in this Appendix A. The borings and CPTs were located by pacing from existing reference points. Therefore, the exploration locations shown on Figure 2 are approximate.

Our field exploration included four exploratory soil borings to depths ranging from 15 to 25 feet below existing grade. Our borings were performed by Clear Heart Drilling under Geocon supervision on November 19, 2020 using a track-mounted DR8K drill rig equipped with 7-inch OD hollow-stem and 4-inch OD solid flash augers. Sampling in the borings was accomplished using an auto hammer 140-pound hammer (hammer efficiency of about 80%) with a 30-inch drop. Samples were obtained with a 3-inch outside-diameter (OD), split spoon (California Modified) sampler, and a 2-inch OD, Standard Penetration Test (SPT) sampler. The number of blows required to drive the sampler the last 12 inches (or fraction thereof) of the 18-inch sampling interval were recorded on the boring logs. The blow counts shown on the boring logs should not be interpreted as standard SPT "N" values; corrections have not been applied.

Our exploration also included three CPT soundings to maximum depths of approximately 90 feet below existing grade utilizing a truck-mounted CPT rig with a down-pressure capacity of approximately 20 tons. The CPTs were performed on November 10, 2020 by Middle Earth Geo Testing using an integrated electronic cone system under Geocon supervision. The cone has a tip area of 15 square centimeters, a friction sleeve area of 225 square centimeters, and a ratio of friction sleeve area to tip end area equal to 0.8. The cone bearing (Q_c) and sleeve friction (F_s) were measured and recorded during tests at approximately 2-inch depth intervals. The CPT data consisting of cone bearing, sleeve friction, friction ratio and equivalent standard penetration blow counts (N) versus penetration depth below the existing ground surface for each location has been recorded and is presented in this appendix.

Subsurface conditions encountered in the exploratory boring were visually examined, classified and logged in general accordance with the American Society for Testing and Materials (ASTM) Practice for Description and Identification of Soils (Visual-Manual Procedure D2488). This system uses the Unified Soil Classification System (USCS) for soil designations. The log depicts soil and geologic conditions encountered and depths at which samples were obtained. The log also includes our interpretation of the conditions between sampling intervals. Therefore, the logs contain both observed and interpreted data. We determined the lines designating the interface between soil materials on the logs using visual observations, drill rig penetration rates, excavation characteristics and other factors. The transition between materials may be abrupt or gradual. Where applicable, the field logs were revised based on subsequent laboratory testing. Upon completion, our soil borings and CPT boreholes were backfilled per Marin County permit requirements.

UNIFIED SOIL CLASSIFICATION

MAJOR DIVISIONS				TYPICAL NAMES
COARSE-GRAINED SOILS MORE THAN HALF IS COARSER THAN NO. 200 SIEVE	GRAVELS MORE THAN HALF COARSE FRACTION IS LARGER THAN NO.4 SIEVE SIZE	CLEAN GRAVELS WITH LITTLE OR NO FINES	GW	WELL GRADED GRAVELS WITH OR WITHOUT SAND, LITTLE OR NO FINES
			GP	POORLY GRADED GRAVELS WITH OR WITHOUT SAND, LITTLE OR NO FINES
		GRAVELS WITH OVER 12% FINES	GM	SILTY GRAVELS, SILTY GRAVELS WITH SAND
			GC	CLAYEY GRAVELS, CLAYEY GRAVELS WITH SAND
	SANDS MORE THAN HALF COARSE FRACTION IS SMALLER THAN NO.4 SIEVE SIZE	CLEAN SANDS WITH LITTLE OR NO FINES	SW	WELL GRADED SANDS WITH OR WITHOUT GRAVEL, LITTLE OR NO FINES
			SP	POORLY GRADED SANDS WITH OR WITHOUT GRAVEL, LITTLE OR NO FINES
		SANDS WITH OVER 12% FINES	SM	SILTY SANDS WITH OR WITHOUT GRAVEL
			SC	CLAYEY SANDS WITH OR WITHOUT GRAVEL
FINE-GRAINED SOILS MORE THAN HALF IS FINER THAN NO. 200 SIEVE	SILTS AND CLAYS LIQUID LIMIT 50% OR LESS	ML	INORGANIC SILTS AND VERY FINE SANDS, ROCK FLOUR, SILTS WITH SANDS AND GRAVELS	
		CL	INORGANIC CLAYS OF LOW TO MEDIUM PLASTICITY, CLAYS WITH SANDS AND GRAVELS, LEAN CLAYS	
		OL	ORGANIC SILTS OR CLAYS OF LOW PLASTICITY	
	SILTS AND CLAYS LIQUID LIMIT GREATER THAN 50%	MH	INORGANIC SILTS, MICACEOUS OR DIATOMACEOUS, FINE SANDY OR SILTY SOILS, ELASTIC SILTS	
		CH	INORGANIC CLAYS OF HIGH PLASTICITY, FAT CLAYS	
		OH	ORGANIC CLAYS OR CLAYS OF MEDIUM TO HIGH PLASTICITY	
	HIGHLY ORGANIC SOILS	PT	PEAT AND OTHER HIGHLY ORGANIC SOILS	

BEDDING SPACING DESCRIPTIONS

THICKNESS/SPACING	DESCRIPTOR
GREATER THAN 10 FEET	MASSIVE
3 TO 10 FEET	VERY THICKLY BEDDED
1 TO 3 FEET	THICKLY BEDDED
3 1/4-INCH TO 1 FOOT	MODERATELY BEDDED
1 1/4-INCH TO 3 1/2-INCH	THINLY BEDDED
1/2-INCH TO 1 1/4-INCH	VERY THINLY BEDDED
LESS THAN 1/2-INCH	LAMINATED

STRUCTURE DESCRIPTIONS

CRITERIA	DESCRIPTION
ALTERNATING LAYERS OF VARYING MATERIAL OR COLOR WITH LAYERS AT LEAST 1/2-INCH THICK	STRATIFIED
ALTERNATING LAYERS OF VARYING MATERIAL OR COLOR WITH LAYERS LESS THAN 1/2-INCH THICK	LAMINATED
BREAKS ALONG DEFINITE PLANES OF FRACTURE WITH LITTLE RESISTANCE TO FRACTURING	FISSURED
FRACTURE PLANES APPEAR POLISHED OR GLOSSY, SOMETIMES STRIATED	SLICKENSIDED
COHESIVE SOIL THAT CAN BE BROKEN DOWN INTO SMALLER ANGULAR LUMPS WHICH RESIST FURTHER BREAKDOWN	BLOCKY
INCLUSION OF SMALL POCKETS OF DIFFERENT SOIL, SUCH AS SMALL LENSES OF SAND SCATTERED THROUGH A MASS OF CLAY	LENSED
SAME COLOR AND MATERIAL THROUGHOUT	HOMOGENOUS

CEMENTATION/INDURATION DESCRIPTIONS

FIELD TEST	DESCRIPTION
CRUMBLES OR BREAKS WITH HANDLING OR LITTLE FINGER PRESSURE	WEAKLY CEMENTED/INDURATED
CRUMBLES OR BREAKS WITH CONSIDERABLE FINGER PRESSURE	MODERATELY CEMENTED/INDURATED
WILL NOT CRUMBLE OR BREAK WITH FINGER PRESSURE	STRONGLY CEMENTED/INDURATED

IGNEOUS/METAMORPHIC ROCK STRENGTH DESCRIPTIONS

FIELD TEST	DESCRIPTION
MATERIAL CRUMBLES WITH BARE HAND	WEAK
MATERIAL CRUMBLES UNDER BLOWS FROM GEOLOGY HAMMER	MODERATELY WEAK
1/2-INCH INDENTATIONS WITH SHARP END FROM GEOLOGY HAMMER	MODERATELY STRONG
HAND-HELD SPECIMEN CAN BE BROKEN WITH ONE BLOW FROM GEOLOGY HAMMER	STRONG
HAND-HELD SPECIMEN CAN BE BROKEN WITH COUPLE BLOWS FROM GEOLOGY HAMMER	VERY STRONG
HAND-HELD SPECIMEN CAN BE BROKEN WITH MANY BLOWS FROM GEOLOGY HAMMER	EXTREMELY STRONG

IGNEOUS/METAMORPHIC ROCK WEATHERING DESCRIPTIONS

DEGREE OF DECOMPOSITION	FIELD RECOGNITION	ENGINEERING PROPERTIES
SOIL	DISCOLORED, CHANGED TO SOIL, FABRIC DESTROYED	EASY TO DIG
COMPLETELY WEATHERED	DISCOLORED, CHANGED TO SOIL, FABRIC MAINLY PRESERVED	EXCAVATED BY HAND OR RIPPING (Saprolite)
HIGHLY WEATHERED	DISCOLORED, HIGHLY FRACTURED, FABRIC ALTERED AROUND FRACTURES	EXCAVATED BY HAND OR RIPPING, WITH SLIGHT DIFFICULTY
MODERATELY WEATHERED	DISCOLORED, FRACTURES, INTACT ROCK-NOTICEABLY WEAKER THAN FRESH ROCK	EXCAVATED WITH DIFFICULTY WITHOUT EXPLOSIVES
SLIGHTLY WEATHERED	MAY BE DISCOLORED, SOME FRACTURES, INTACT ROCK-NOT NOTICEABLY WEAKER THAN FRESH ROCK	REQUIRES EXPLOSIVES FOR EXCAVATION, WITH PERMEABLE JOINTS AND FRACTURES
FRESH	NO DISCOLORATION, OR LOSS OF STRENGTH	REQUIRES EXPLOSIVES

IGNEOUS/METAMORPHIC ROCK JOINT/FRACTURE DESCRIPTIONS

FIELD TEST	DESCRIPTION
NO OBSERVED FRACTURES	UNFRACTURED/UNJOINTED
MAJORITY OF JOINTS/FRACTURES SPACED AT 1 TO 3 FOOT INTERVALS	SLIGHTLY FRACTURED/JOINTED
MAJORITY OF JOINTS/FRACTURES SPACED AT 4-INCH TO 1 FOOT INTERVALS	MODERATELY FRACTURED/JOINTED
MAJORITY OF JOINTS/FRACTURES SPACED AT 1-INCH TO 4-INCH INTERVALS WITH SCATTERED FRAGMENTED INTERVALS	INTENSELY FRACTURED/JOINTED
MAJORITY OF JOINTS/FRACTURES SPACED AT LESS THAN 1-INCH INTERVALS; MOSTLY RECOVERED AS CHIPS AND FRAGMENTS	VERY INTENSELY FRACTURED/JOINTED

BORING/TRENCH LOG LEGEND

	PENETRATION RESISTANCE						
	SAND AND GRAVEL			SILT AND CLAY			
	RELATIVE DENSITY	BLOWS PER FOOT (SPT)*	BLOWS PER FOOT (MOD-CAL)*	CONSISTENCY	BLOWS PER FOOT (SPT)*	BLOWS PER FOOT (MOD-CAL)*	COMPRESSIVE STRENGTH (tsf)
— No Recovery	VERY LOOSE	0 - 4	0 - 6	VERY SOFT	0 - 2	0 - 3	0 - 0.25
— Shelby Tube Sample	LOOSE	5 - 10	7 - 16	SOFT	3 - 4	4 - 6	0.25 - 0.50
— Bulk Sample	MEDIUM DENSE	11 - 30	17 - 48	MEDIUM STIFF	5 - 8	7 - 13	0.50 - 1.0
— SPT Sample	DENSE	31 - 50	49 - 79	STIFF	9 - 15	14 - 24	1.0 - 2.0
— Modified California Sample	VERY DENSE	OVER 50	OVER 79	VERY STIFF	16 - 30	25 - 48	2.0 - 4.0
— Groundwater Level (At Completion)				HARD	OVER 30	OVER 48	OVER 4.0
— Groundwater Level (Seepage)							

*NUMBER OF BLOWS OF 140 LB HAMMER FALLING 30 INCHES TO DRIVE LAST 12 INCHES OF AN 18-INCH DRIVE

MOISTURE DESCRIPTIONS

FIELD TEST	APPROX. DEGREE OF SATURATION, S (%)	DESCRIPTION
NO INDICATION OF MOISTURE; DRY TO THE TOUCH	S < 25	DRY
SLIGHT INDICATION OF MOISTURE	25 ≤ S < 50	DAMP
INDICATION OF MOISTURE; NO VISIBLE WATER	50 ≤ S < 75	MOIST
MINOR VISIBLE FREE WATER	75 ≤ S < 100	WET
VISIBLE FREE WATER	100	SATURATED

QUANTITY DESCRIPTIONS

APPROX. ESTIMATED PERCENT	DESCRIPTION
<5%	TRACE
5 - 10%	FEW
11 - 25%	LITTLE
26 - 50%	SOME
>50%	MOSTLY

GRAVEL/COBBLE/BOULDER DESCRIPTIONS

CRITERIA	DESCRIPTION
PASS THROUGH A 3-INCH SIEVE AND BE RETAINED ON A NO. 4 SIEVE (#4 TO 3")	GRAVEL
PASS A 12-INCH SQUARE OPENING AND BE RETAINED ON A 3-INCH SIEVE (3"-12")	COBBLE
WILL NOT PASS A 12-INCH SQUARE OPENING (>12")	BOULDER

KEY TO LOGS



GEOCON
CONSULTANTS, INC.

2420 MARTIN ROAD, SUITE 380 - FAIRFIELD, CA 94534
PHONE 925.961.5271 - FAX 925.371.5915

DEPTH IN FEET	SAMPLE NO.	LITHOLOGY	GROUNDWATER	SOIL CLASS (USCS)	BORING B1		PENETRATION RESISTANCE (BLOWS/FT.)	DRY DENSITY (P.C.F.)	MOISTURE CONTENT (%)
					ELEV. (MSL.) _____	DATE COMPLETED <u>11/19/2020</u>			
					ENG./GEO. <u>AA</u>	DRILLER <u>Clear Heart Drilling</u>			
					EQUIPMENT <u>DR8k Track Rig w/ 7" HSA</u>	HAMMER TYPE <u>Auto-hammer</u>			
MATERIAL DESCRIPTION									
0					Approximately 2 inches of AC				
1					Approximately 9 inches of AB				
2	B1-1.5 B1-2			CL	FILL		45		5.3
3					Hard, damp, black to dark brown, CLAY with (f) sand				
4				SC	Medium dense, wet, brown, Clayey SAND with trace (f) gravel				
5	B1-4.5						20		12.4
6				CH	BAY MUD				
7	B1-6.5 B1-7				Very soft, gray, wet, fat CLAY		3	57.1	67.4
8					-some organics at the top				
9	B1-8.5-10.5				-pp<1/4			42.4	110.0
10									
11									
12									
13									
14									
15									
16									
17									
18									
19									
20	B1-19.5				-pp<1/4		0	54	74.3
					END OF BORING AT APPROXIMATELY 20 FEET GROUNDWATER INITIALLY ENCOUNTERED AT APPROXIMATELY 4 FEET BACKFILLED WITH NEAT GROUT CEMENT				

Figure A2, Log of Boring B1, Page 1 of 1



SAMPLE SYMBOLS		
	... SAMPLING UNSUCCESSFUL	
	... DISTURBED OR BAG SAMPLE	
	... STANDARD PENETRATION TEST	
	... CHUNK SAMPLE	
		... WATER TABLE OR SEEPAGE

NOTE: THE LOG OF SUBSURFACE CONDITIONS SHOWN HEREON APPLIES ONLY AT THE SPECIFIC BORING OR TRENCH LOCATION AND AT THE DATE INDICATED. IT IS NOT WARRANTED TO BE REPRESENTATIVE OF SUBSURFACE CONDITIONS AT OTHER LOCATIONS AND TIMES.

DEPTH IN FEET	SAMPLE NO.	LITHOLOGY	GROUNDWATER	SOIL CLASS (USCS)	BORING B2		PENETRATION RESISTANCE (BLOWS/FT.)	DRY DENSITY (P.C.F.)	MOISTURE CONTENT (%)
					ELEV. (MSL.) _____	DATE COMPLETED <u>11/19/2020</u>			
					ENG./GEO. <u>AA</u>	DRILLER <u>Clear Heart Drilling</u>			
					EQUIPMENT <u>DR8k Track Rig w/ 7" HSA</u>	HAMMER TYPE <u>Auto-hammer</u>			
MATERIAL DESCRIPTION									
0					Approximately 3 inches of AC				
1					Approximately 9 inches of AB				
2	B2-1.5-2.5			CL	FILL		21		
3	B2-2.5-3.5			GC	Moist, dark brown, CLAY with (f) sand				
4	B2-4.5			CL	Medium dense, moist, olive, GRAVEL with (m) sand, clay, and silt				
5			▼		Stiff, moist, brown, (f-m) Sandy CLAY		13		12.3
7	B2-6.5			CH	BAY MUD		9		
8	B2-7				Soft, moist, gray and olive, fat CLAY				
9					-pp < 1/4				
10	B2-9.5				-very soft, gray		0		
11					-pp < 1/4				
14	B2-14.5				-pp < 1/4		0	49.0	83.1
15									
16									
17									
18									
19									
20									
21									
22									
23									
24	B2-24.5				-pp < 1/4		0	64.3	54.2
25					END OF BORING AT APPROXIMATELY 25 FEET				
					GROUNDWATER INITIALLY ENCOUNTERED AT APPROXIMATELY 5 FEET				
					BACKFILLED WITH NEAT GROUT CEMENT				

Figure A3, Log of Boring B2, Page 1 of 1



SAMPLE SYMBOLS		
	... SAMPLING UNSUCCESSFUL	
	... DISTURBED OR BAG SAMPLE	
	... STANDARD PENETRATION TEST	
	... CHUNK SAMPLE	
		... WATER TABLE OR SEEPAGE

NOTE: THE LOG OF SUBSURFACE CONDITIONS SHOWN HEREON APPLIES ONLY AT THE SPECIFIC BORING OR TRENCH LOCATION AND AT THE DATE INDICATED. IT IS NOT WARRANTED TO BE REPRESENTATIVE OF SUBSURFACE CONDITIONS AT OTHER LOCATIONS AND TIMES.

DEPTH IN FEET	SAMPLE NO.	LITHOLOGY	GROUNDWATER	SOIL CLASS (USCS)	BORING B3		PENETRATION RESISTANCE (BLOWS/FT.)	DRY DENSITY (P.C.F.)	MOISTURE CONTENT (%)
					ELEV. (MSL.) _____	DATE COMPLETED <u>11/19/2020</u>			
					ENG./GEO. <u>AA</u>	DRILLER <u>Clear Heart Drilling</u>			
					EQUIPMENT <u>DR8k Track Rig w/ 4" SFA</u>	HAMMER TYPE <u>Auto-hammer</u>			
MATERIAL DESCRIPTION									
0					Approximately 4 inches of AC				
1	B3-1-3			CL	Approximately 8 inches of AB				
2	B3-1.5-2.5				FILL		12	116.9	15.1
3				SC	Medium stiff, moist, brown/olive, CLAY with (f) sand -pp=1¼				
4			▼		Loose, wet, dark brown/black, Clayey (f-m) SAND with trace (f) gravel				
5	B3-4.5-5						10		12.5
6				CH	BAY MUD				
7	B3-6.5-7.5				Very soft, wet, black/olive/gray, fat CLAY with trace (f) sand -pp<¼		2		47.2
8									
9							0		
10	B3-9.5				-gray, no sand -pp<¼				
11									
12									
13									
14							0	51.1	82.4
15	B3-14.5				END OF BORING AT APPROXIMATELY 15 FEET GROUNDWATER INITIALLY ENCOUNTERED AT APPROXIMATELY 4 FEET BACKFILLED WITH NEAT GROUT CEMENT				

Figure A4, Log of Boring B3, Page 1 of 1



SAMPLE SYMBOLS		
	... SAMPLING UNSUCCESSFUL	
	... DISTURBED OR BAG SAMPLE	
	... STANDARD PENETRATION TEST	
	... CHUNK SAMPLE	
		... WATER TABLE OR SEEPAGE

NOTE: THE LOG OF SUBSURFACE CONDITIONS SHOWN HEREON APPLIES ONLY AT THE SPECIFIC BORING OR TRENCH LOCATION AND AT THE DATE INDICATED. IT IS NOT WARRANTED TO BE REPRESENTATIVE OF SUBSURFACE CONDITIONS AT OTHER LOCATIONS AND TIMES.

DEPTH IN FEET	SAMPLE NO.	LITHOLOGY	GROUNDWATER	SOIL CLASS (USCS)	BORING B4		PENETRATION RESISTANCE (BLOWS/FT.)	DRY DENSITY (P.C.F.)	MOISTURE CONTENT (%)
					ELEV. (MSL.) _____	DATE COMPLETED <u>11/19/2020</u>			
					ENG./GEO. <u>AA</u>	DRILLER <u>Clear Heart Drilling</u>			
					EQUIPMENT <u>DR8k Track Rig w/ 7" HSA</u>	HAMMER TYPE <u>Auto-hammer</u>			
MATERIAL DESCRIPTION									
0					Approximately 6 inches of AC				
1	B4-1.3			CL	Approximately 5½ inches of AB				
2					FILL				
3					Stiff, moist, brown, (f) Sandy CLAY and trace (f) gravel				
4	B4-3.5 B4-4			GM	Medium dense, moist, brown, Silty (f-c) GRAVEL with (f-m) sand		29	128.4	13.4
5			▼						8.1
6				CH	BAY MUD				
7					Very soft to soft, wet, gray, fat CLAY		2		
8									
9					-pp<¼		2		
10	B4-9.5							50.8	81.0
11									
12									
13									
14									
15									
16									
17									
18									
19					-very soft		0	56.1	69.1
20	B4-19.5								
					END OF BORING AT APPROXIMATELY 20 FEET GROUNDWATER INITIALLY ENCOUNTERED AT 5 FEET BACKFILLED WITH NEAT GROUT CEMENT				

Figure A5, Log of Boring B4, Page 1 of 1



SAMPLE SYMBOLS		
	... SAMPLING UNSUCCESSFUL	
	... DISTURBED OR BAG SAMPLE	
	... STANDARD PENETRATION TEST	
	... CHUNK SAMPLE	
		... WATER TABLE OR SEEPAGE

NOTE: THE LOG OF SUBSURFACE CONDITIONS SHOWN HEREON APPLIES ONLY AT THE SPECIFIC BORING OR TRENCH LOCATION AND AT THE DATE INDICATED. IT IS NOT WARRANTED TO BE REPRESENTATIVE OF SUBSURFACE CONDITIONS AT OTHER LOCATIONS AND TIMES.



Geocon Inc.

Project Vivian Street Townhome
 Job Number E9226-04-01
 Hole Number CPT-01
 EST GW Depth During Test _____

Operator BH-AJ
 Cone Number DDG1496
 Date and Time 11/10/2020 8:04:44 AM
 5.00 ft

Filename SDF(364).cpt
 GPS _____
 Maximum Depth 81.86 ft

Net Area Ratio .8

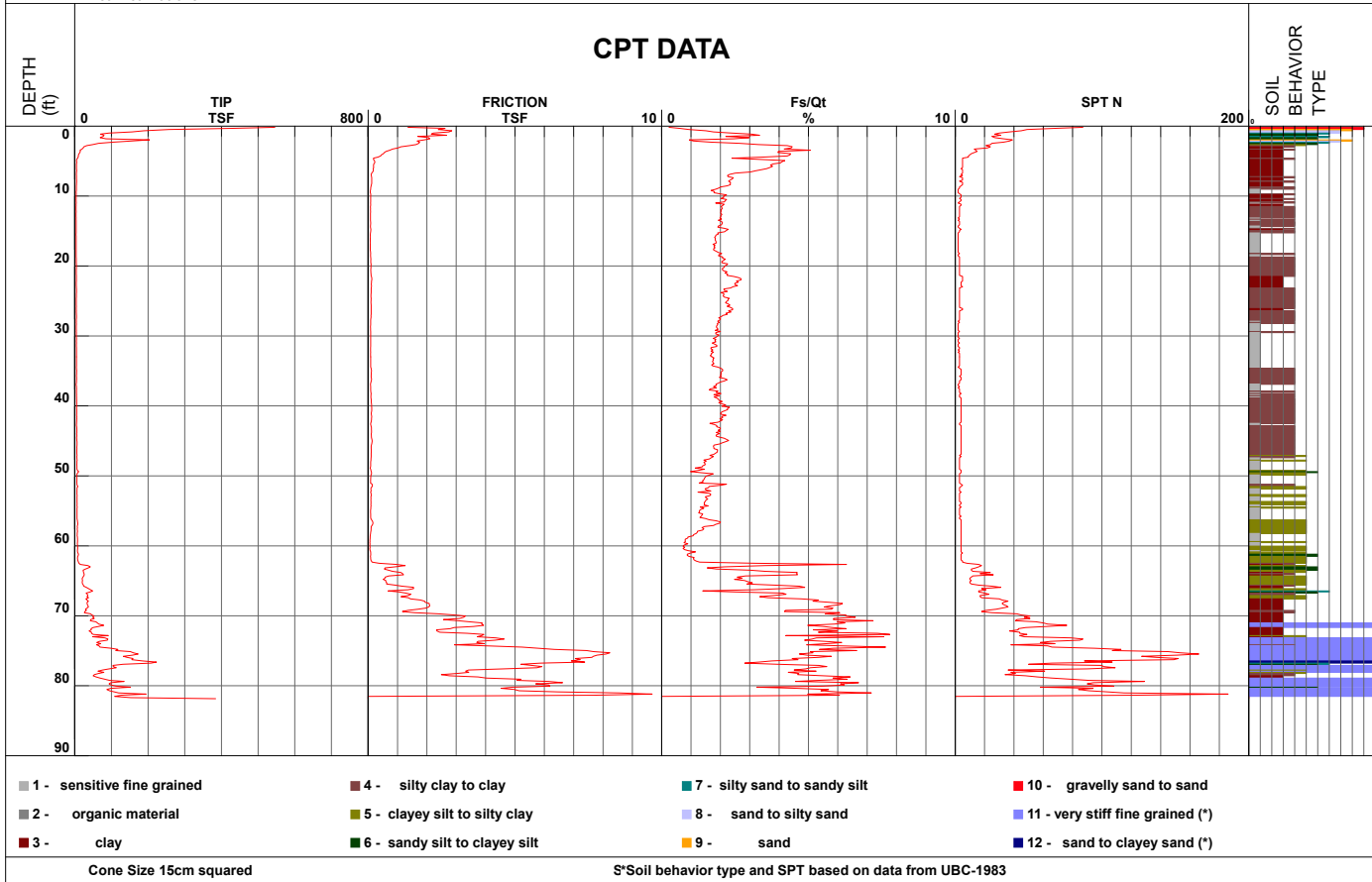

CONE PENETROMETER TEST DATA - CPT-1

Project: Vivian Street Townhomes
 Project No. E9226-04-01
 Date: January 2021

FIGURE A6



Geocon Inc.

Project Vivian Street Townhome Operator BH-AJ Filename SDF(365).cpt
Job Number E9226-04-01 Cone Number DDG1496 GPS _____
Hole Number CPT-02 Date and Time 11/10/2020 11:01:20 AM Maximum Depth 83.33 ft
EST GW Depth During Test 4.00 ft

Net Area Ratio .8

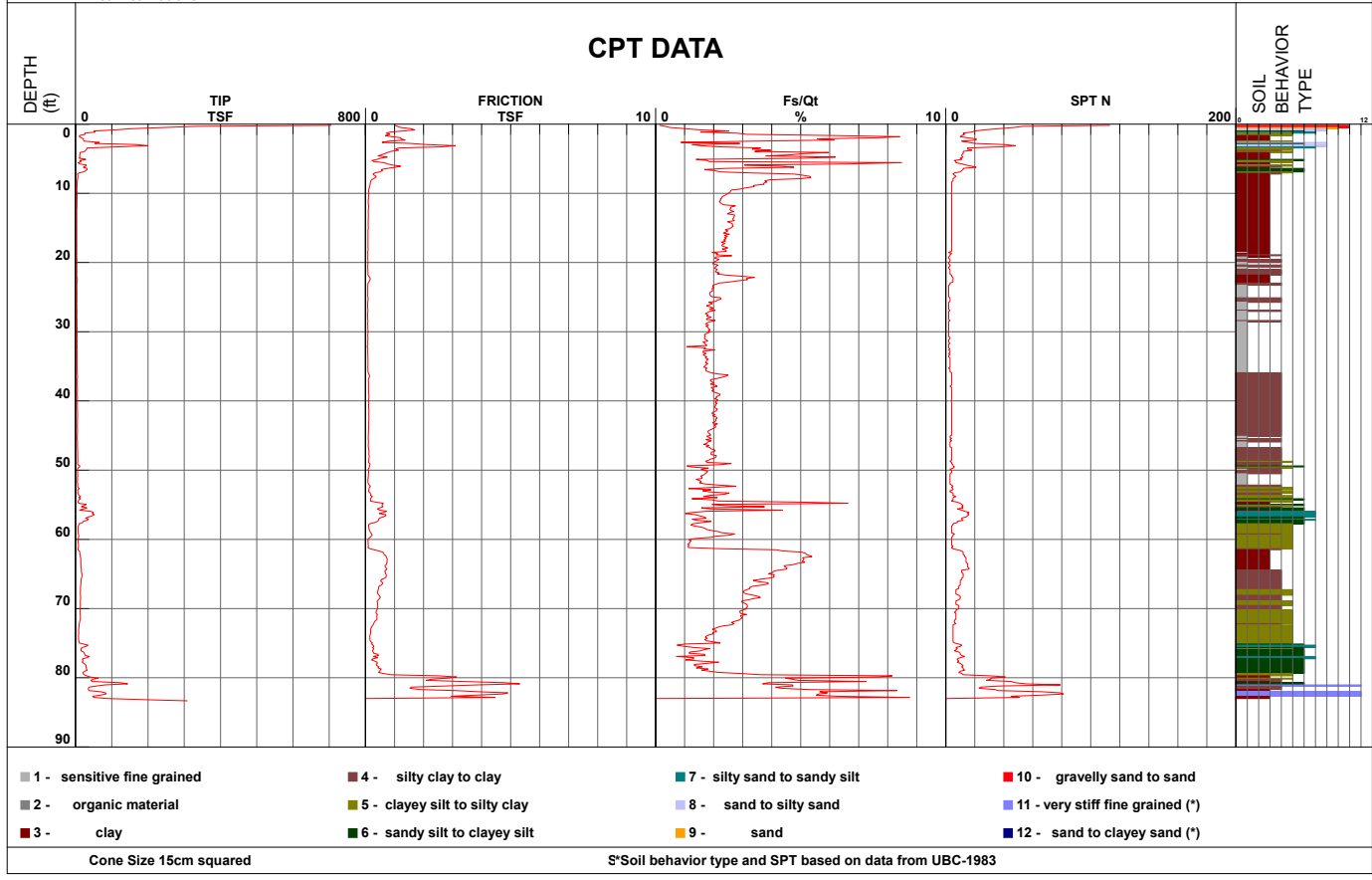

CONE PENETROMETER TEST DATA - CPT-2

Project: Vivian Street Townhomes
Project No. E9226-04-01
Date: January 2021

FIGURE A7



Geocon Inc.

Project	Vivian Street Townhome	Operator	BH-AJ	Filename	SDF(366).cpt
Job Number	E9226-04-01	Cone Number	DDG1496	GPS	
Hole Number	CPT-03	Date and Time	11/10/2020 2:08:57 PM	Maximum Depth	89.40 ft
EST GW Depth During Test			7.00 ft		

Net Area Ratio .8

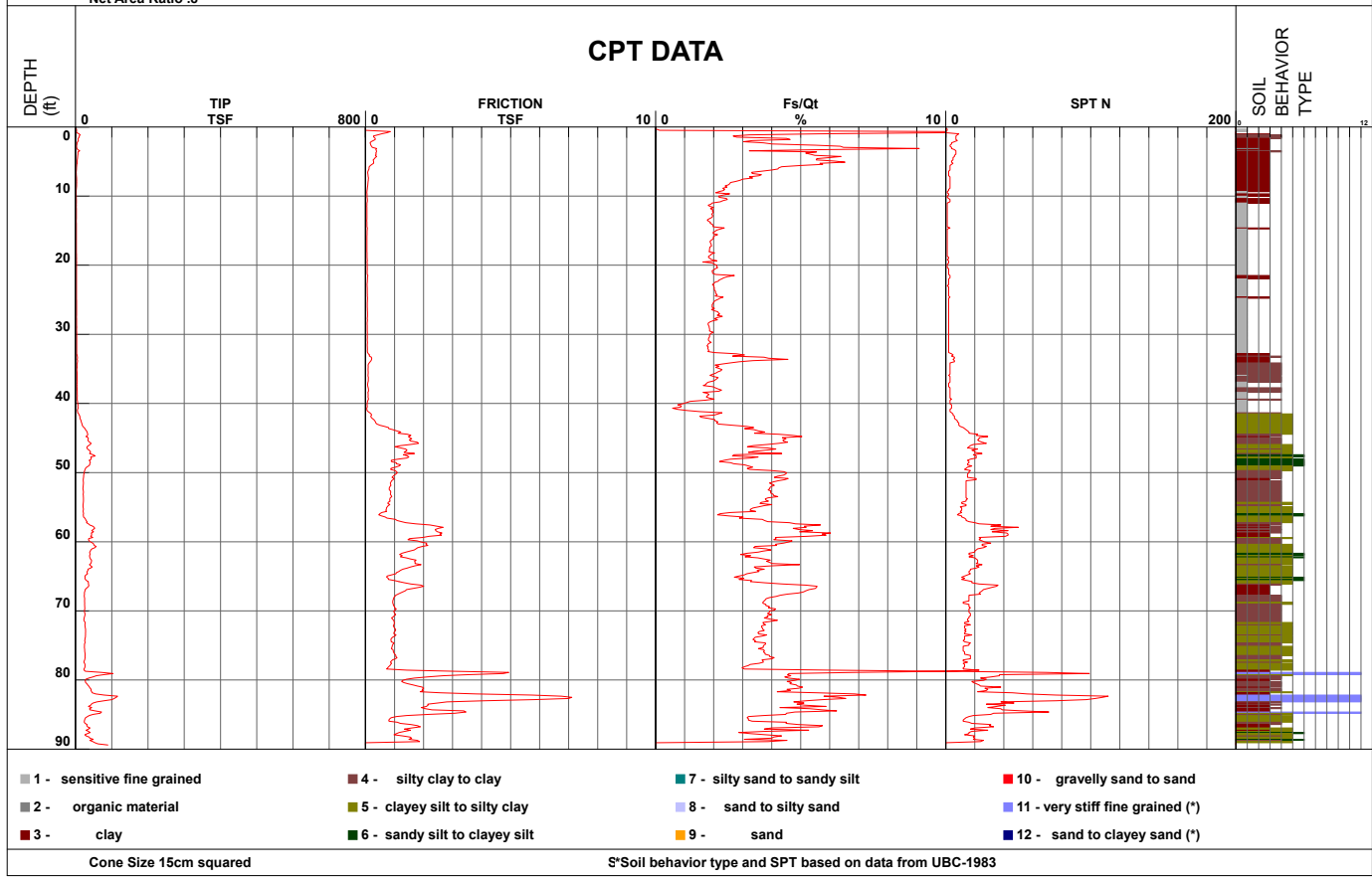

CONE PENETROMETER TEST DATA - CPT-3

Project: Vivian Street Townhomes
 Project No. E9226-04-01
 Date: January 2021

FIGURE A8

APPENDIX

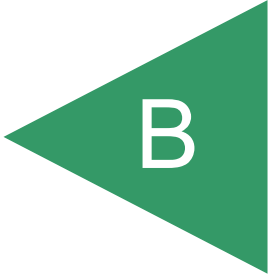

**APPENDIX B
LABORATORY TESTING**

Laboratory tests were performed in accordance with generally accepted test methods of the American Society for Testing and Materials (ASTM) or other suggested procedures. Selected samples were tested for in-situ dry density and moisture content, grain size distribution, plasticity, expansion index, and screening-level corrosion parameters. The results of our testing are summarized in tabular format below and the following figures. In-situ dry density and moisture content test results are included on the boring logs in Appendix A.

**TABLE B-I
SUMMARY OF LABORATORY ATTERBERG LIMITS TEST RESULTS
ASTM D 4318**

Sample No.	Liquid Limit	Plastic Limit	Plasticity Index
B2/B3/B4-1-3.5	41	17	24
B2-7	93	36	57
B3-14.5	98	34	64

**TABLE B-II
SUMMARY OF LABORATORY EXPANSION INDEX TEST RESULTS
ASTM D 4829**

Sample No.	Moisture Content		Dry Density* (pcf)	Expansion Index
	Before Test (%)	After Test (%)		
B2/B3/B4-1-3.5	9.3	19.2	112.9	60

*Before saturation.

**TABLE B-III
SUMMARY OF LABORATORY GRAIN SIZE ANALYSIS - NO. 200 WASH
ASTM D1140**

Boring No.	Sample Depth (feet)	Fraction Passing No. 200 Sieve (%)
B1	4.5	25.6
B2	4-5	55.5
B3	4.5-5	32.3

**TABLE B-IV
SUMMARY OF SOIL CORROSION PARAMETERS
(CTM 643, CTM 417, CTM 422)**

Boring No. (sample depth in feet)	Soil Type (USCS Classification)	Resistivity (ohm-cm)	pH	Chloride (ppm)	Sulfate (ppm)
B1 (1-1.5)	Sandy CLAY(Fill/CL)	950	7.5	154	25
B2/B3/B4(1-3.5')	Sandy CLAY/Clayey SAND(Fill/CL/SC)	1,000	7.6	198	21

*Caltrans considers a site corrosive to foundation elements if one or more of the following conditions exist for the representative soil samples at the site:

- The pH is equal to or less than 5.5.
- Chloride concentration is equal to or greater than 500 parts per million (ppm) or 0.05%.
- Sulfate concentration is equal to or greater than 2,000 ppm (0.2%)

**According to the American Concrete Institute 318 Chapter 19, Type II cement may be used where sulfate levels are below 2,000 ppm (0.2%)

**CONSOLIDATION TEST - ASTM D2435
STRESS VERSUS STRAIN**

Project Name	Vivian Street Townhomes
Geocon Project Number	E9226-04-01
Boring Number	B1
Sample Number	B1-8.5-10.5
Sample Description	Very Dark Gray Fat CLAY

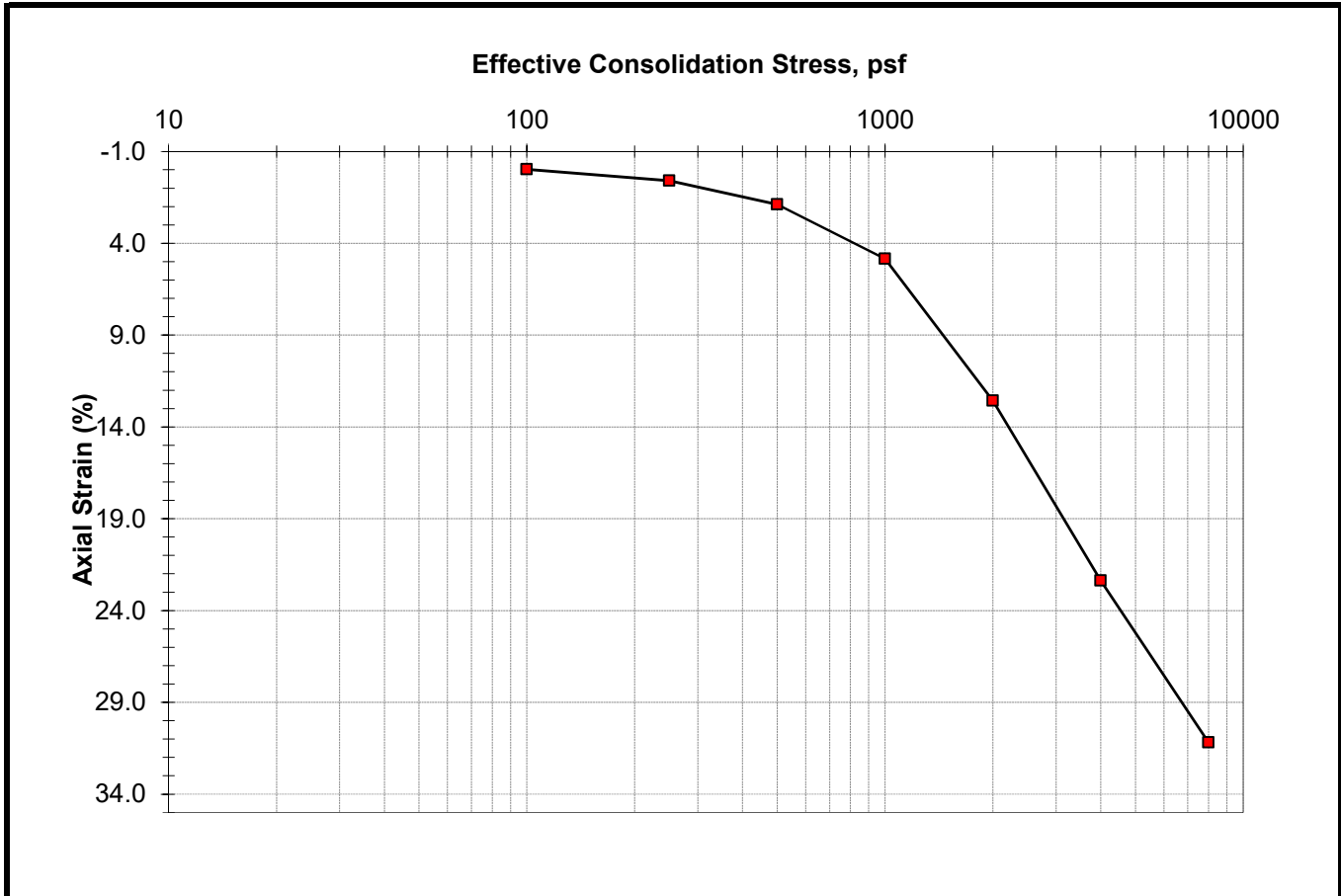

Axial Load, psf	Void Ratio	Axial Strain, %	Measurement	Initial	Final
initial	3.196	0.00	Height (in.)	0.750	0.516
100	3.197	-0.03	Moisture Content (%)	110.0	65.8
250	3.171	0.60	Dry Density (pcf)	42.4	61.6
500	3.117	1.88	Saturation (%)	98	99
1000	2.993	4.84	Note:		
2000	2.669	12.57	Gs = 2.85 (assumed)		
4000	2.257	22.37	 3160 Gold Valley Drive, Suite 800 Rancho Cordova, CA 95742 tel. 916.852-9118 fax. 916.852.9132		
8000	1.888	31.19			

Figure B1



CORRIS	GRAVEL		SAND			SILT OR CLAY
	coarse	fine	coarse	medium	fine	

Boring: B4

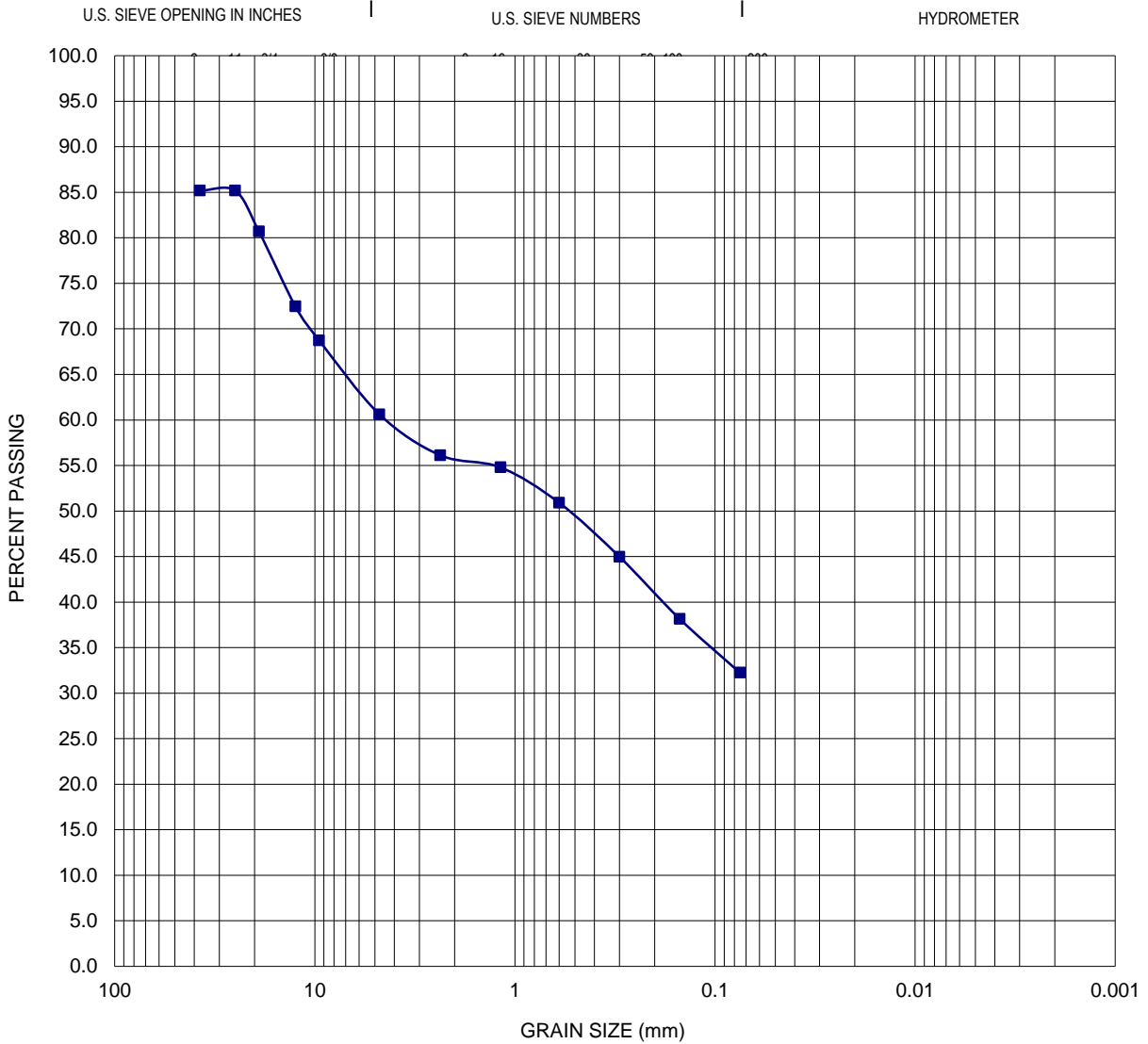
Sieve Date: 12/7/2020

Depth To Sample: 4'

Tested and Computed by: AC

Test Data

Sieve Number	1 1/2"	1"	3/4"	1/2"	3/8"	#4	#8	#16	#30	#50	#100	#200
% Passing	85.2	85.2	80.7	72.5	68.7	60.6	56.1	54.8	50.9	45.0	38.1	32.2



Geocon Consultants, Inc.
 6671 Brisa Street
 Livermore, CA 94550
 Telephone: (925) 371-5900
 Fax: (925) 371-5915

Particle Size Analysis - ASTM D422

Project: Vivian St. Townhomes
Location: San Rafael, CA
Project No.: E9226-04-01

Figure B2

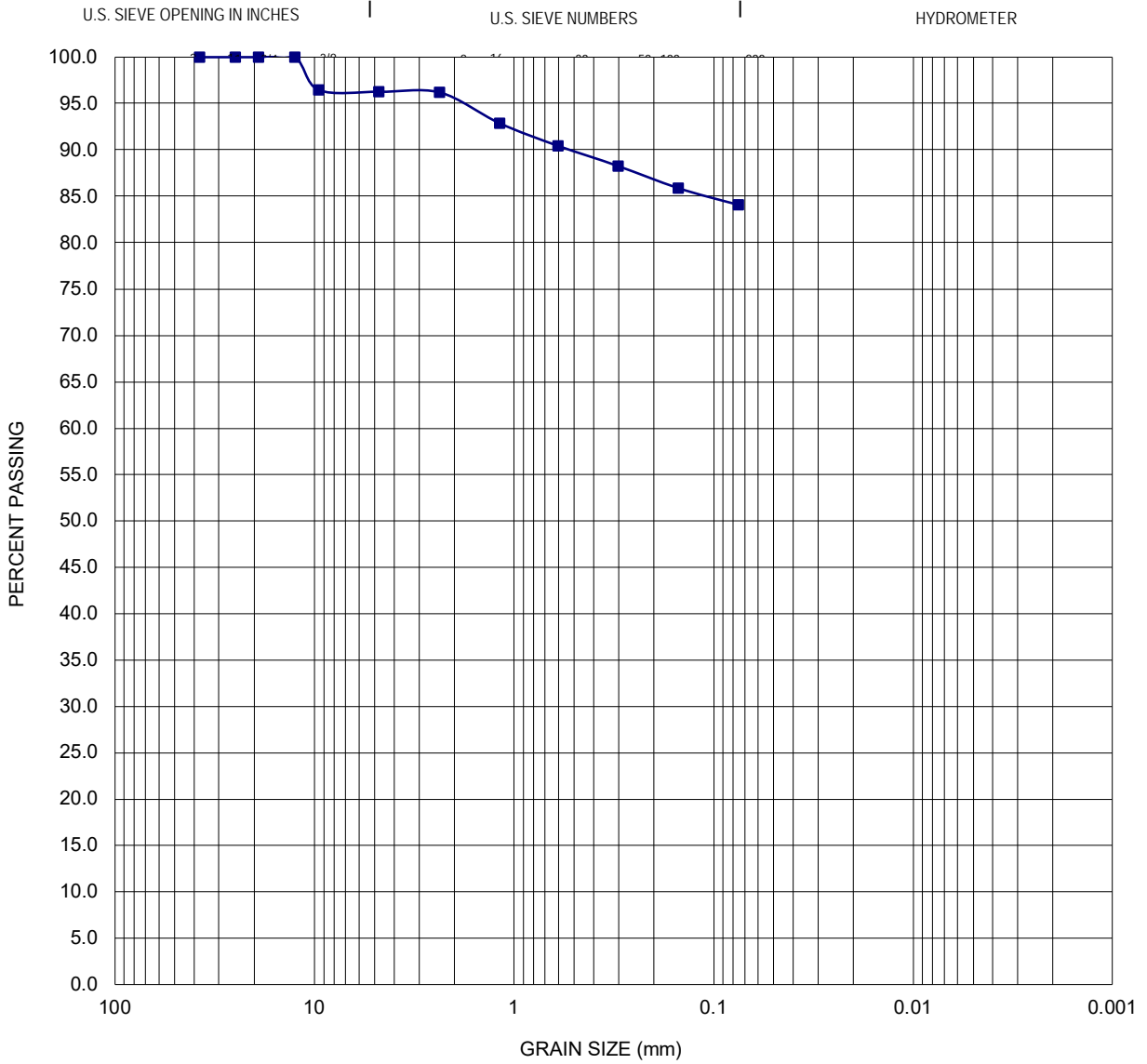

COBBLES	GRAVEL		SAND			SILT OR CLAY
	coarse	fine	coarse	medium	fine	

Boring: B2/B3

Sieve Date: 12/4/2020

Depth To Sample: 1'-3.5'

Tested and Computed by: TG

Test Data

Sieve Number	1 1/2"	1"	3/4"	1/2"	3/8"	#4	#8	#16	#30	#50	#100	#200
% Passing	100.0	100.0	100.0	100.0	96.5	96.2	96.2	92.9	90.4	88.3	85.9	84.1



Geocon Consultants, Inc.
 6671 Brisa Street
 Livermore, CA 94550
 Telephone: (925) 371-5900
 Fax: (925) 371-5915

Particle Size Analysis - ASTM D422

Project: Vivian St. Townhomes
Location: San Rafael, CA
Project No.: E9226-04-01

Figure B3

APPENDIX

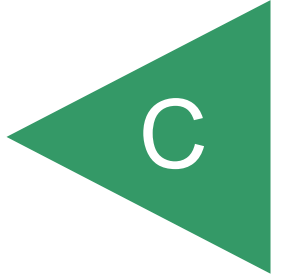

APPENDIX C
GROUND MOTION HAZARD ANALYSIS

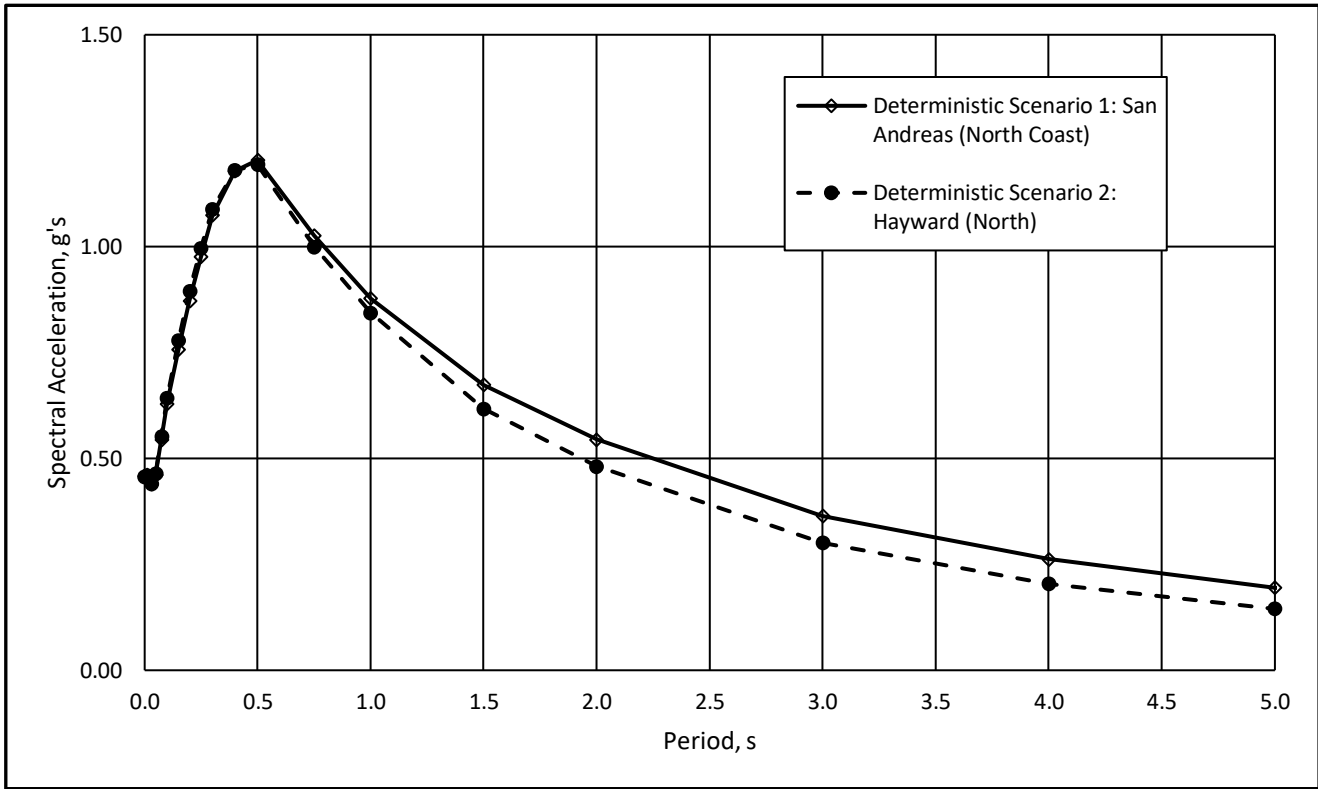
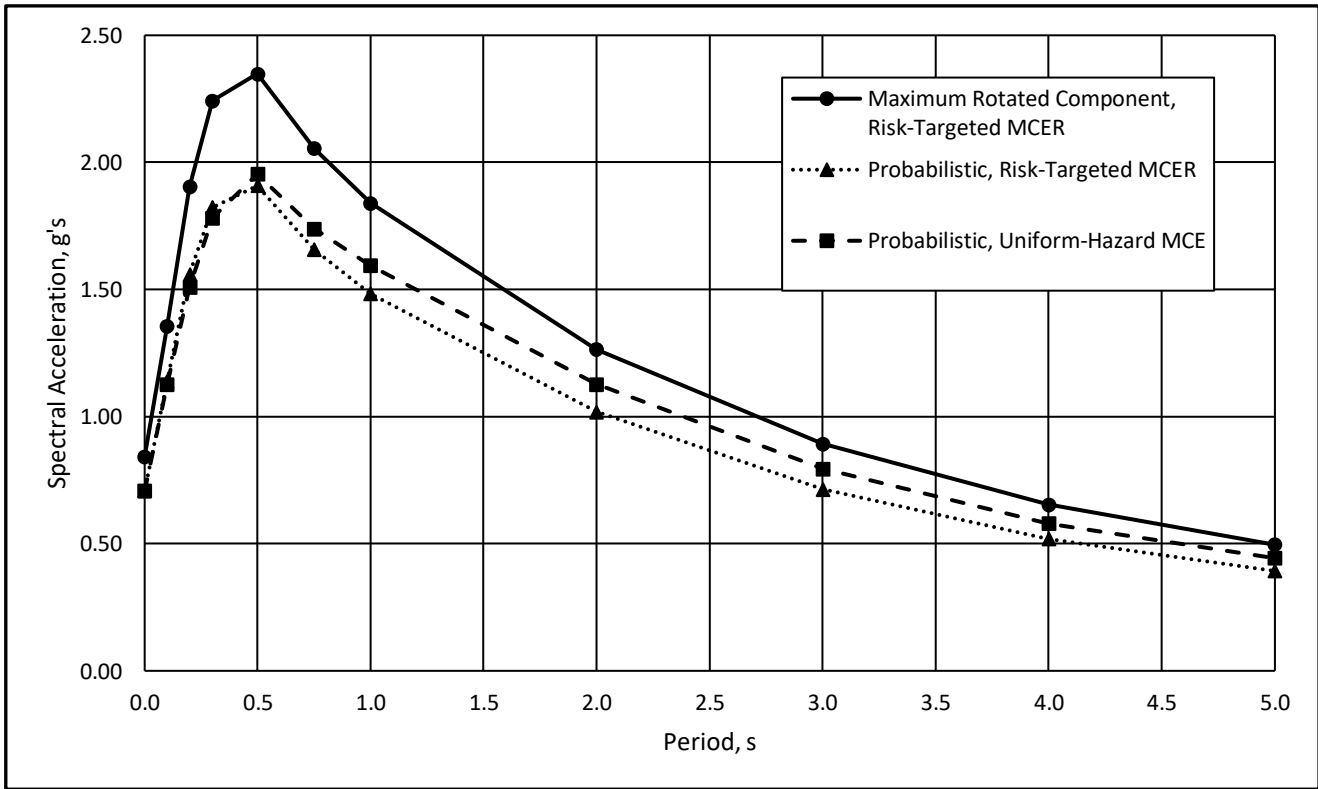

DESIGN RESPONSE SPECTRUM

Checked by: JA

Project No.: E9226-04-01
 Vivian Street Townhomes
 San Rafael, CA
 Dec 20
 Figure C1

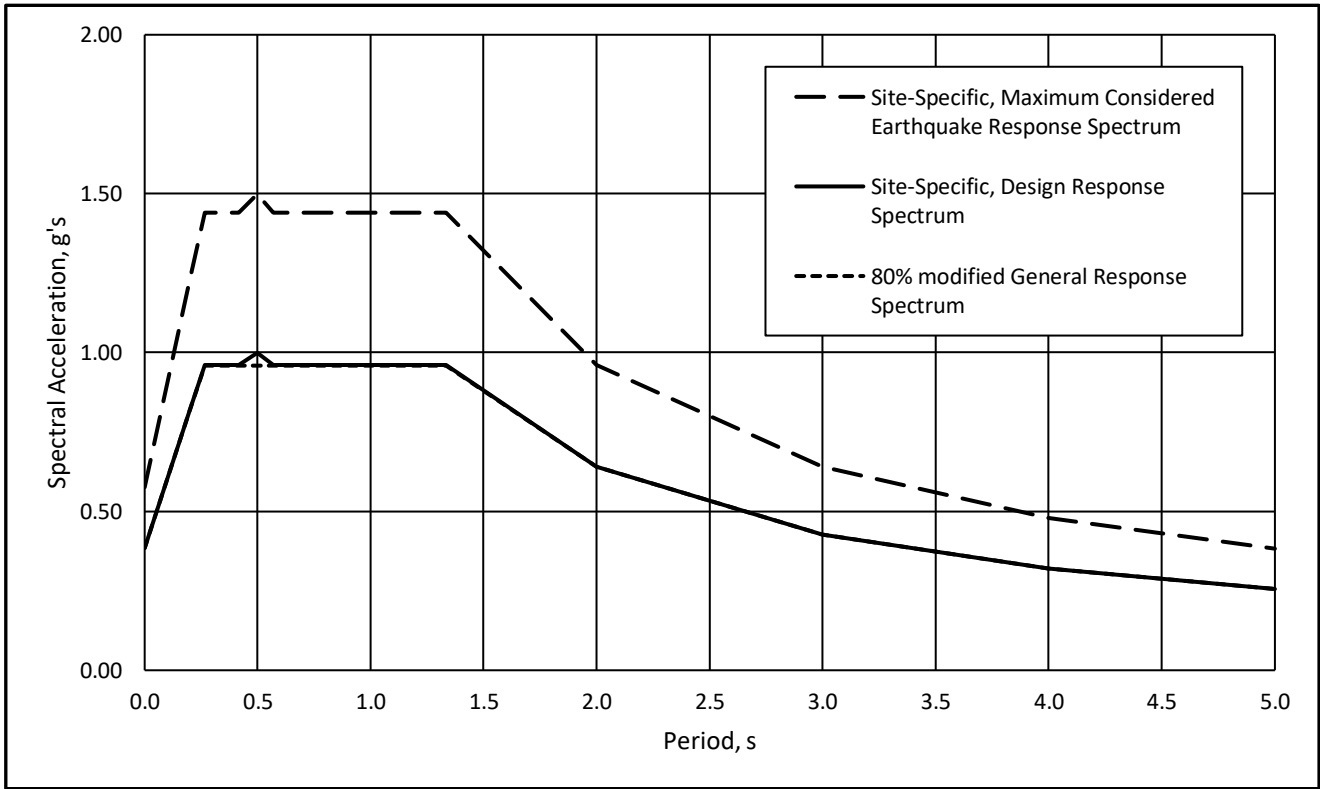
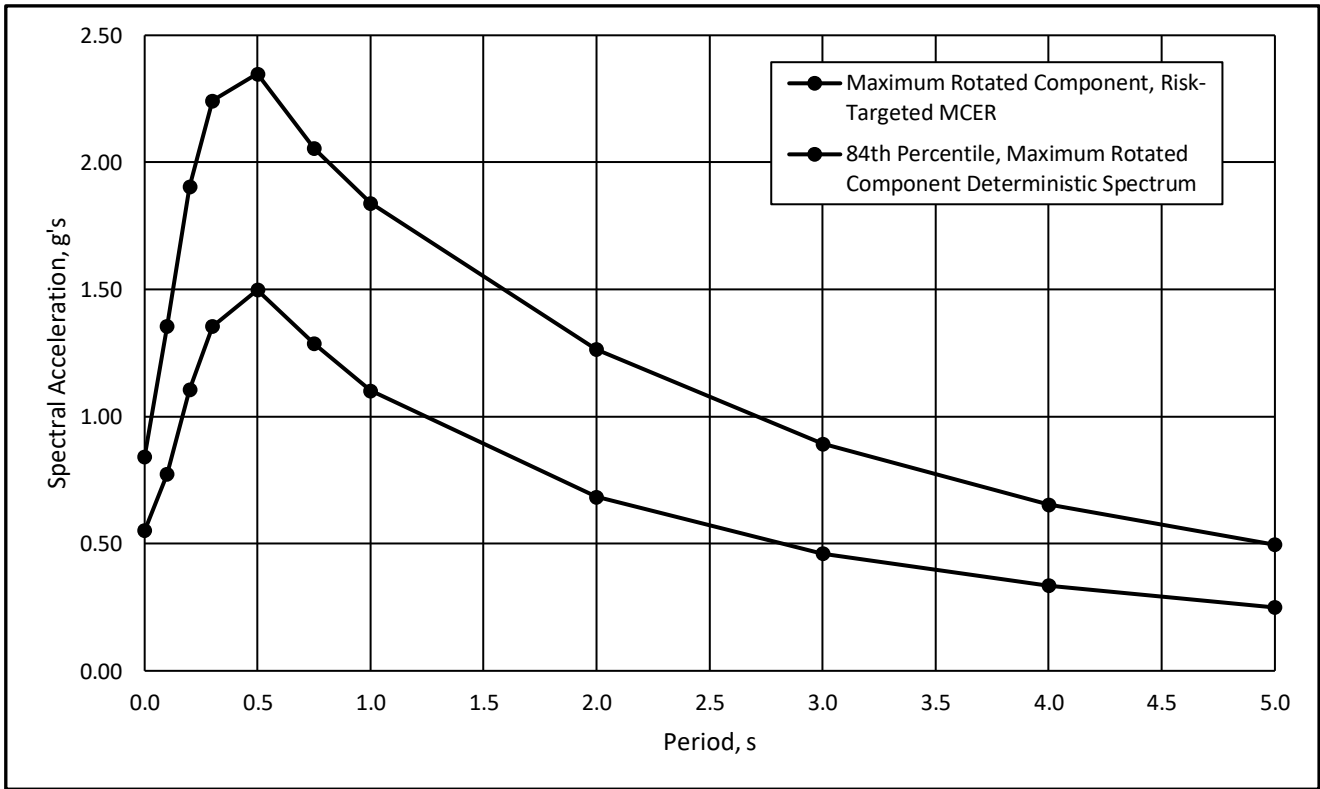

DESIGN RESPONSE SPECTRUM

Checked by: JA

Project No.: E9226-04-01
 Vivian Street Townhomes
 San Rafael, CA
 Dec 20 Figure C2

Spectral Period (seconds)	Probabilistic Uniform-Hazard	Risk-Targeted, Probabilistic	Risk Factor, Cr	Maximum-Rotated Component Scale Factor	MRC, Risk-Targeted Probabilistic	84th Percentile, Deterministic	Site-Specific Design Earthquake	80% Modified General Response Spectrum	Site-Specific Maximum Considered Earthquake
0.00	0.708	0.708	1.000	1.190	0.843	0.552	0.384	0.384	0.576
0.10	1.126	1.139	1.011	1.190	1.355	0.774	0.600	0.600	0.900
0.20	1.509	1.560	1.034	1.220	1.903	1.106	0.816	0.816	1.224
0.27	--	--	--	--	--	--	0.960	0.960	1.440
0.30	1.782	1.823	1.023	1.230	2.242	1.355	0.960	0.960	1.440
0.42	--	--	--	--	--	--	0.960	0.960	1.440
0.50	1.954	1.909	0.977	1.230	2.348	1.500	1.000	0.960	1.500
0.57	--	--	--	--	--	--	0.960	0.960	1.440
0.75	1.739	1.657	0.953	1.240	2.055	1.287	0.960	0.960	1.440
1.00	1.594	1.484	0.931	1.240	1.840	1.102	0.960	0.960	1.440
1.33	--	--	--	--	--	--	0.960	0.960	1.440
2.00	1.127	1.019	0.905	1.240	1.264	0.684	0.640	0.640	0.960
3.00	0.795	0.714	0.898	1.250	0.893	0.461	0.427	0.427	0.640
4.00	0.580	0.519	0.894	1.260	0.654	0.335	0.320	0.320	0.480
5.00	0.444	0.394	0.887	1.260	0.497	0.249	0.256	0.256	0.384

$$SM_5 = \frac{1.440}{1.920} g$$

$$SM_1 = \frac{1.920}{1.280} g$$

$$SD_5 = \frac{0.960}{1.280} g$$

$$SD_1 = \frac{1.280}{1.280} g$$

Reference: ASCE 7-16 21.4 DESIGN ACCELERATION PARAMETERS

Where the site-specific procedure is used to determine the design ground motion in accordance with Section 21.3, the parameter S_{DS} shall be taken as 90% of the maximum spectral acceleration, S_a , obtained from the site-specific spectrum, at any period within the range from 0.2 to 5 s, inclusive. The parameter S_{D1} shall be taken as the maximum value of the product, TS_a , for periods from 1 to 2 s for sites with $V_{s,30} > 1,200$ ft/s ($V_{s,30} > 365.76$ m/s) and for periods from 1 to 5 s for sites with $V_{s,30} \leq 1,200$ ft/s ($V_{s,30} \leq 365.76$ m/s). The parameters S_{MS} and S_{M1} shall be taken as 1.5 times S_{DS} and S_{D1} , respectively. The values so obtained shall not be less than 80% of the values determined in accordance with Section 11.4.3 for S_{MS} and S_{M1} and Section 11.4.5 for S_{DS} and S_{D1} .

"--" Indicates that spectral period was not used at that calculation step

	DESIGN RESPONSE SPECTRUM	Project No.: E9226-04-01
		Vivian Street Townhomes San Rafael, CA
	Checked by: JA	Dec 20

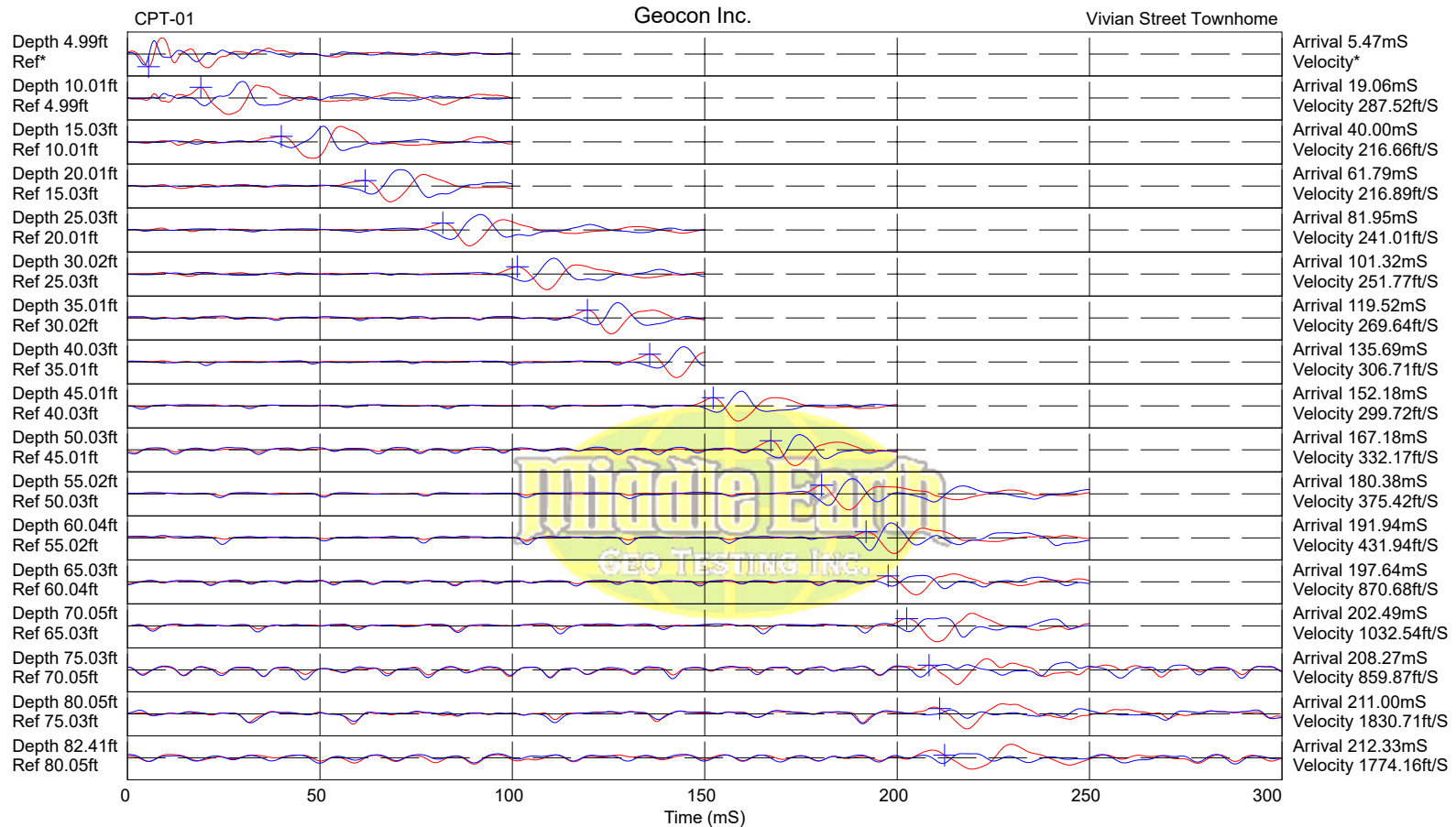

Hammer to Rod String Distance (ft): 5.83

* = Not Determined

COMMENT:

APPENDIX

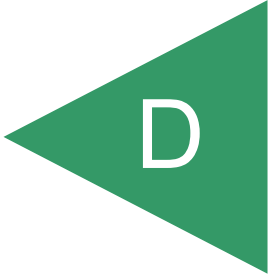

APPENDIX D
LIQUEFACTION ANALYSIS

Overlay Normalized Plots

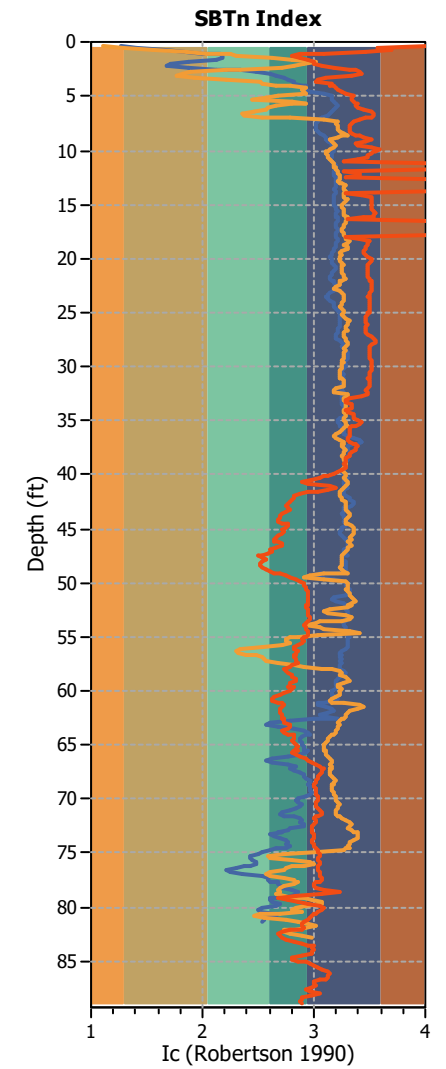
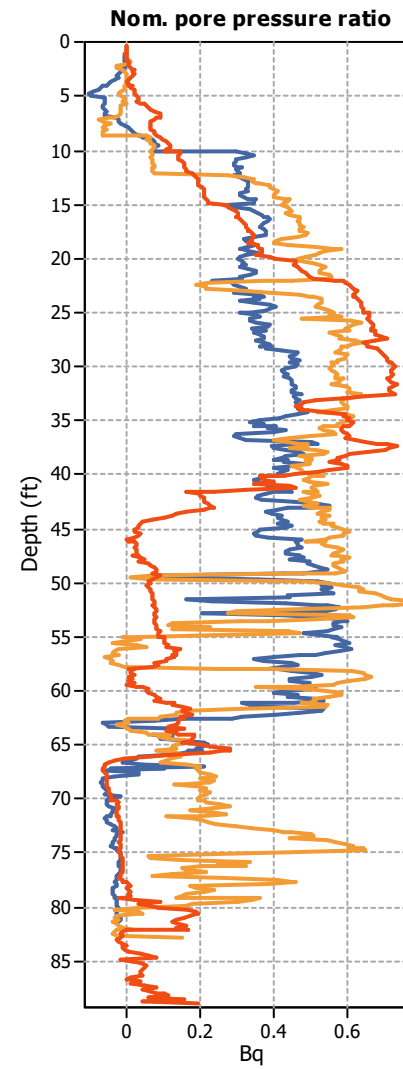
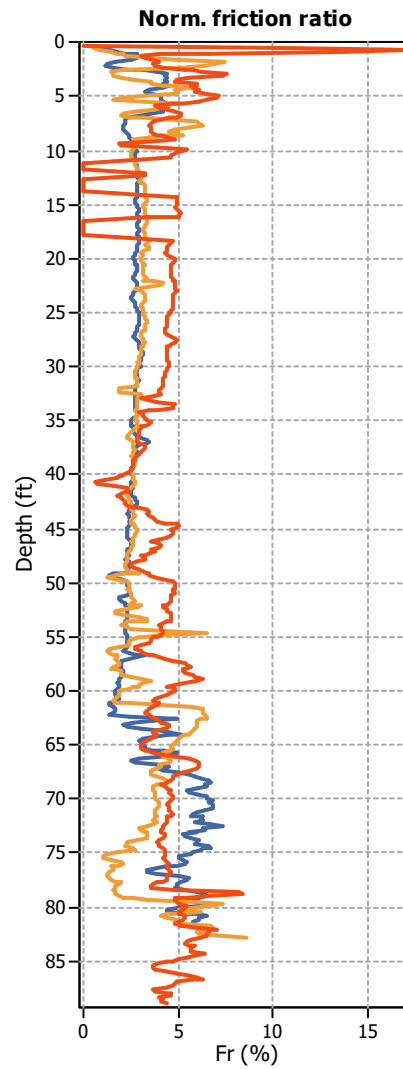
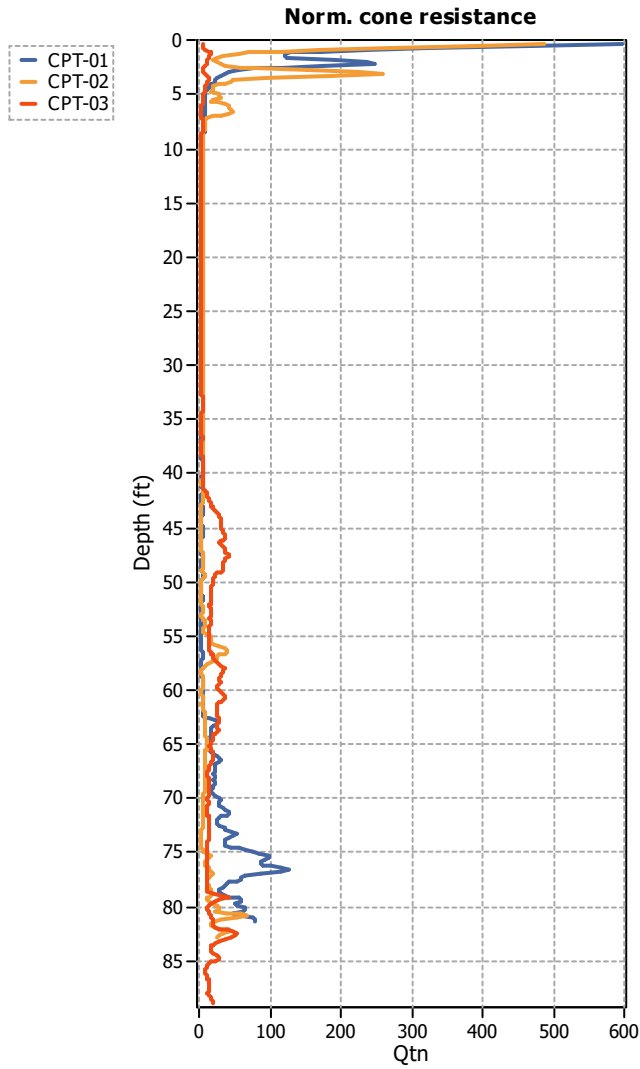

Project: Vivian Street Townhomes

Overlay Intermediate Results

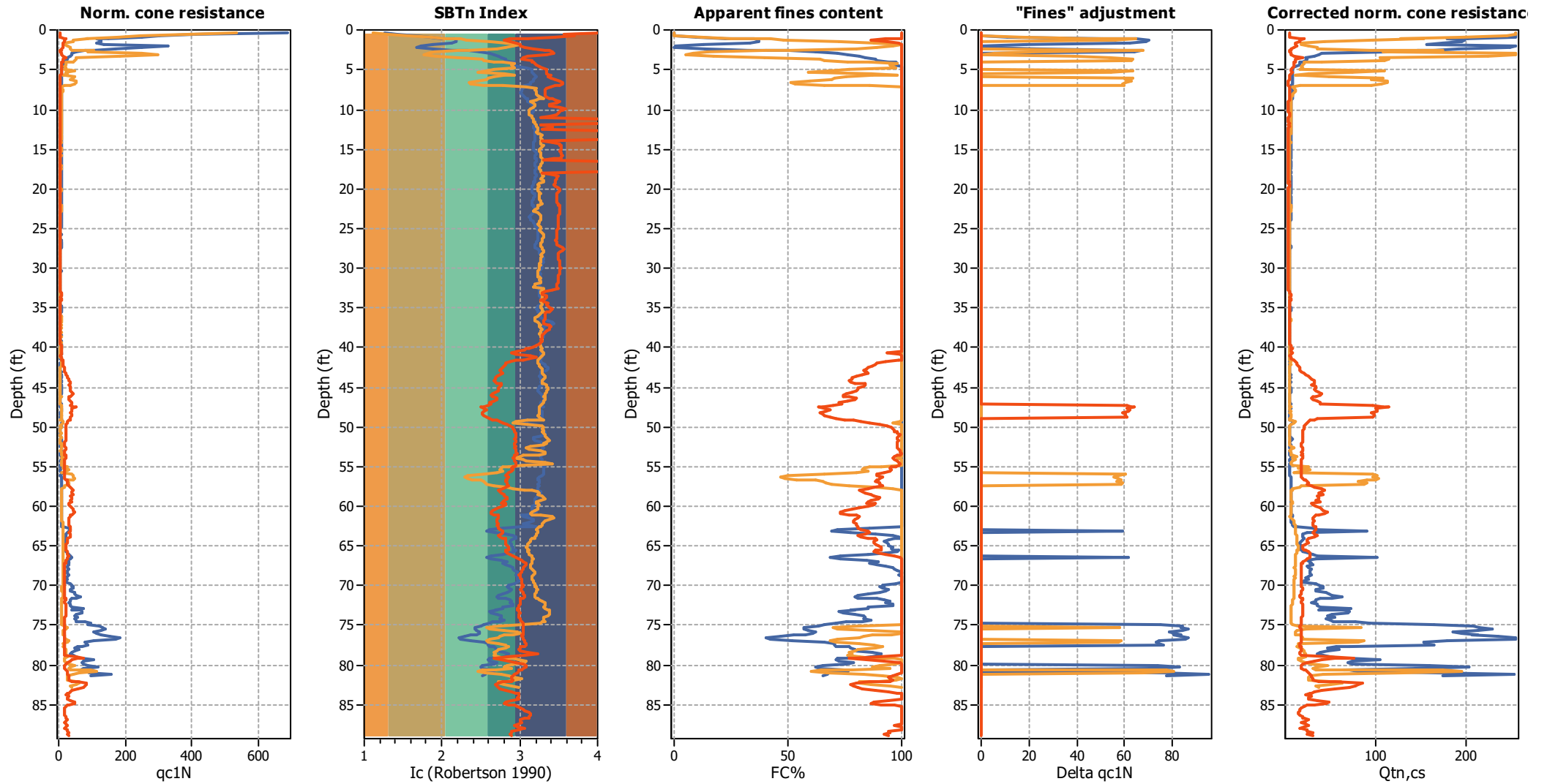

Overlay Cyclic Liquefaction Plots

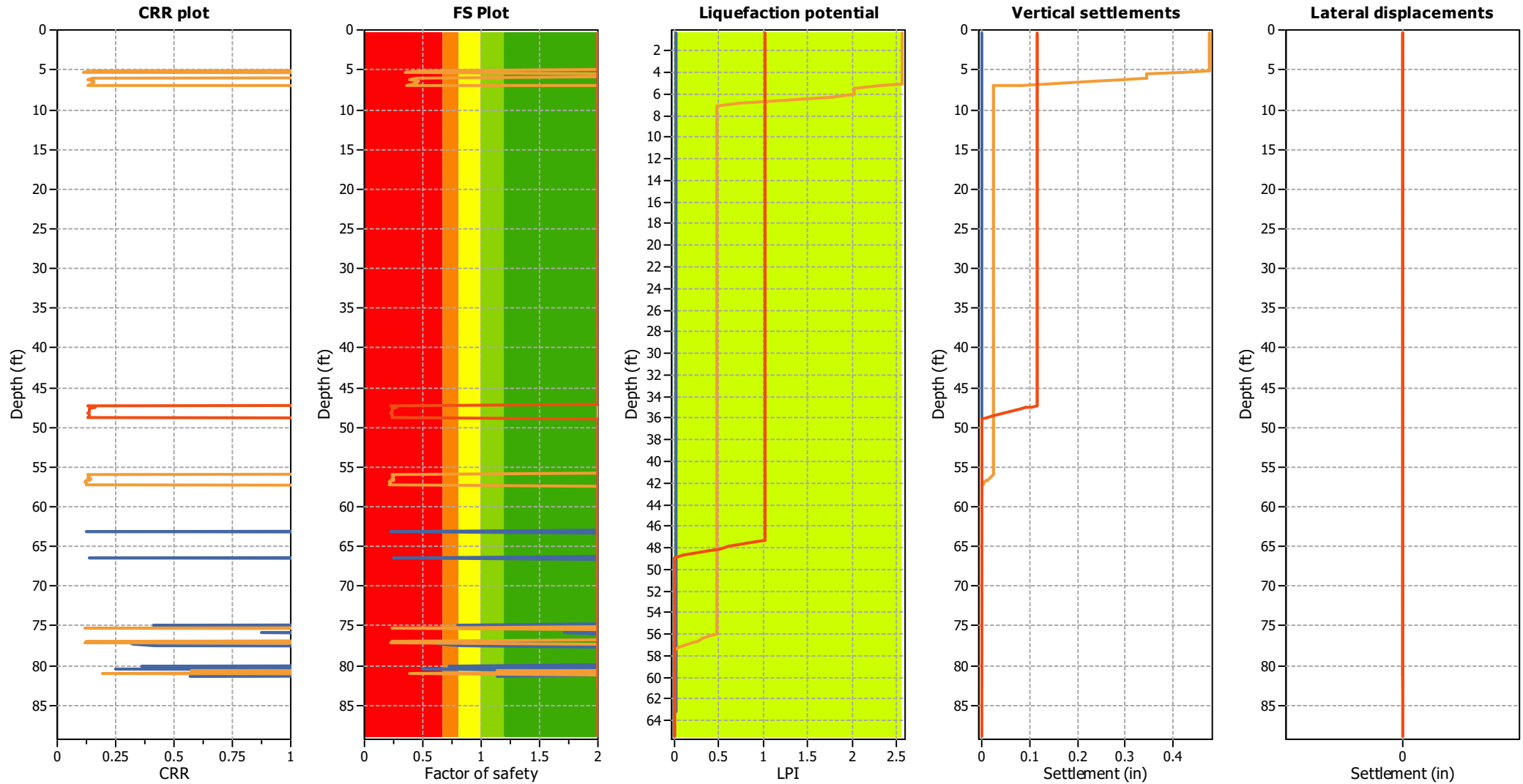

Project: Vivian Street Townhomes

Overlay Strength Loss Plots

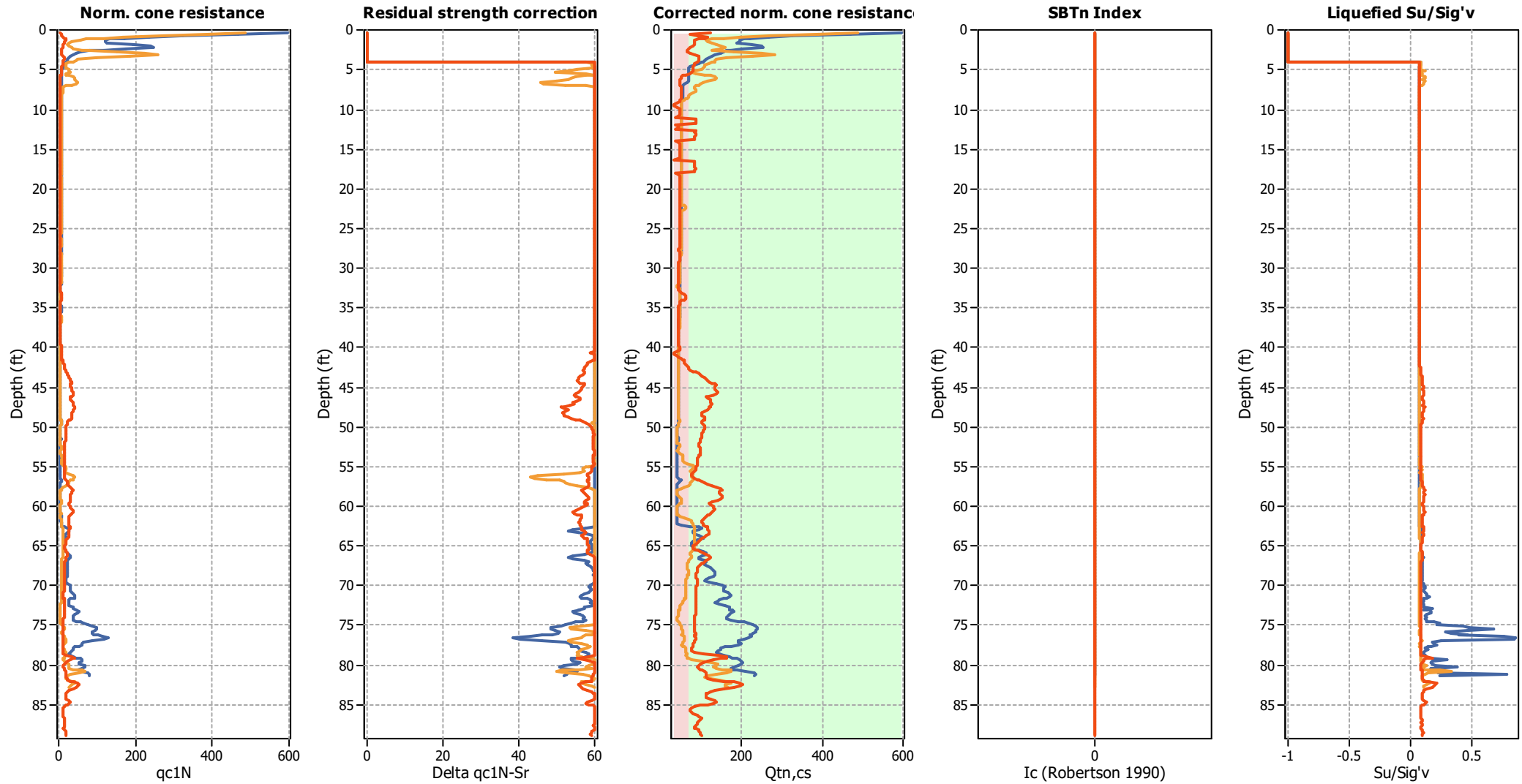

LIST OF REFERENCES

- Abrahamson, N.A, Silva, W.J, and Kamai, R., 2014, *Summary of the ASK14 Ground Motion Relation for Active Crustal Regions*, *Earthquake Spectra*, Volume 30, No. 3, pages 1025-1055, August 2014.
- American Concrete Institute, *Building Code Requirements for Structural Concrete and Commentary*, ACI 318-14, 2014.
- American Society of Civil Engineers (ASCE), *Minimum Design Loads for Buildings and Other Structures*, ASCE Standard ASCE/SEI 7-16, 2017.
- Boore, D.M., Stewart, J.P., Seyhan, E., and Atkinson, G.M., 2014, *NGA-West2 Equations for Predicting PGA, PGV, and 5% Damped PSA for Shallow Crustal Earthquakes*, *Earthquake Spectra*, Volume 30, No. 3, pages 1057-1085, August 2014.
- Boulanger, R.W. and Idriss, I.M., *CPT and SPT Based Liquefaction Triggering Procedures*, UC Davis Center for Geotechnical Modeling Report No. UCD/CGM-14/01, April 2014.
- California Building Standards Commission, *2019 California Building Code*, based on *2018 International Building Code*, International Code Council.
- California Department of Transportation, *Corrosion Guidelines*, Version 3.0, March 2018.
- California Geological Survey (CGS) and United States Geological Survey (USGS) Quaternary Faults and Folds database, online: <http://geohazards.usgs.gov/qfaults/map.php>, accessed June 2020.
- California Geological Survey (CGS), *Earthquake Fault Zones, A Guide for Government Agencies, Property Owners/Developers, and Geoscience Practitioners for Assessing Fault Rupture Hazards in California*, *Special Publication 42*, Revised 2018.
- California Geological Survey, *Tsunami Inundation Map For Emergency Planning –San Rafael/San Quentin Quadrangle, State of California – Marin County*, dated July 1, 2009.
- CGS, *Guidelines for Evaluating and Mitigating Seismic Hazards in California*, *Special Publication 117A*, 2008.
- Campbell, K.W. and Bozorgnia, Y., 2014, *NGA-West2 Ground Motion Model for the Average Horizontal Components of PGA, PGV, and 5% Damped Linear Acceleration Response Spectra*, *Earthquake Spectra*, Volume 30, No. 3, pages 1087-1115, August 2014.
- Chiou, B. S.-J., and Youngs, R.R., 2014, *Update of the Chiou and Youngs NGA Model for the Average Horizontal Component of Peak Ground Motion and Response Spectra*, *Earthquake Spectra*, Volume 30, No. 3, pages 1117-1153, August 2014.
- Geologismiki and Gregg Drilling, Inc., CLiq v. 2.2.0.35, ©2006.
- Geologismiki and Gregg Drilling, Inc., CPeT-IT v. 2.02.5, ©2007.
- Graymer, R.W. et al, *Geologic Map of the San Francisco Bay Region*, USGS Scientific Investigation Map, 2006.
- Idriss, I. M., and Boulanger, R.W., *Semi-empirical Procedures for Evaluating Liquefaction Potential During Earthquakes*, *Soil Dynamics and Earthquake Engineering* 26,115–30, 2006.
- Idriss, I.M. and Boulanger, R.W., *Soil Liquefaction During Earthquakes*, *Engineering Monograph MNO-12*, *Earthquake Engineering Research Institute, Oakland, CA*, 2008.
- Jennings, C.W. and Bryant, W. A., *2010 Fault Activity Map of California*, CGS Geologic Data Map No. 6, online: <http://www.quake.ca.gov/gmaps/FAM/faultactivitymap.html>.
- OpenSha, *Site Data Application, Version 1.4.0*, <http://opensha.org/apps>, accessed June 2020.
- OSHPD *Seismic Design Maps Web Application*, <https://seismicmaps.org/>, accessed June 2020.
- Portland Cement Association, *Concrete Floors on Ground*, 2001.

- Pradel, D., *Procedure to Evaluate Earthquake-Induced Settlements in Dry Sandy Soils*, ASCE Journal of Geotechnical and Geoenvironmental Engineering, April 1998.
- Risk Engineering, *EZ-FRISK Version 7.65*, 2018.
- Shahi, S.K., Baker, J.W., 2013, *NGA-West2 Models for Ground-Motion Directionality*, Pacific Earthquake Engineering Research Center, PEER 2013/10.
- Shahi, S.K., Baker, J.W., 2014, *NGA-West2 Models for Ground-Motion Directionality*, *Earthquake Spectra*, Volume 30, o.3, pages 1285-1300, August 2014.
- Wagner, D.L, et al., *Geologic Map of San Francisco-San Jose Quadrangle, California. 1:250,000*, United States Geological Survey, 1991.
- USGS, *BSSC2014 (Scenario Catalog)*, <https://earthquake.usgs.gov/scenarios/catalog/bssc2014/>, accessed June 2020.
- USGS, *NSHMP_HAZ Response Spectral Application*, <https://earthquake.usgs.gov/nshmp-haz-ws/apps/spectra-plot.html/>, accessed June 2020.
- USGS, *Unified Hazard Tool*, <https://earthquake.usgs.gov/hazards/interactive/>, accessed June 2020.
- USGS, *Bay Area Seismic Velocity Model, Release 8.3.0*, accessed June 2020.
- USGS, *US Seismic Design Maps*: <https://earthquake.usgs.gov/designmaps/beta/us/>, accessed June 2020.
- USGS, *Liquefaction Susceptibility*: <https://earthquake.usgs.gov/learn/topics/geologicmaps/liquefaction.php>, accessed June 2020.
- Youd, T.L. and Garris, C.T., *Liquefaction-Induced Ground-Surface Disruption*, ASCE Journal of Geotechnical Engineering, November 1995.
- Youd, T. Leslie, et al., *Liquefaction Resistance of Soils: Summary Report from the 1996 NCEER and 1998 NCEER/NSF Workshops on Evaluation of Liquefaction Resistance of Soils*, April 2001.
- Youd, T. L. and Idriss, I. M., *Summary Report, Proceedings of the NCEER Workshop on Evaluation of Liquefaction Resistance of Soils*, NCEER Report NCEER-97-0022, pp. 1-40, 1997.