



Guidelines for 2020 Banner Reservations

Types of Banners & Locations:

Vertical Banners (Pole Banners)

We have two banners on 63 light poles from Tamalpais to H Street (refer to 2020 Banner Location Template). This makes for a total of up to 126 banners. You may choose which poles you wish to use, and you may hang one or two banners on each light pole (indicate street, sidewalk, or both). Installation must be for at least one block.

Horizontal Banners (Across the Street Banners)

1. Fourth Street and Tamalpais Avenue (east end)
 2. Fourth Street and Second Street (west end)
- See attached specifications and examples.

Guidelines:

- The banner poles in Downtown San Rafael are for use by the City of San Rafael and any San Rafael based non-profit organization advertising an event within the City limits. The City of San Rafael may pre-empt use of the poles for a City banner at any time.
- An application shall not be accepted more than one year in advance. Reservations begin at the start of the calendar year on a first-come-first-served basis. **2020 Requests are accepted Oct. 1, 2019 by email.**
- The required fee must be paid prior to the hanging of the banner(s).
- An Insurance Certificate for \$1,000,000 liability coverage must be submitted with an additional endorsement naming the City of San Rafael as additionally insured.
- Before installation, the City shall review and approve banner text, materials and colors.
- All banners must be two-sided.
- Banners must be delivered to the Community Services Department at 618 B Street, 5-7 business days before the hanging period or they may not be hung. Fees paid will be forfeited if banners are not delivered on time.
- The City will not store banner(s) unless other arrangements are made.
- Based on space availability, banner(s) may be hung for a maximum of three weeks at a time, unless the City approves a longer period.
- The City of San Rafael is not responsible for damaged sustained to the banner(s) due to acts of nature.

Fees:

- | | |
|--------------------------|----------|
| • Each Horizontal Banner | \$275.00 |
| • Each Vertical Banner | \$25.00 |

Make checks payable to the "City of San Rafael", send to Attn: Library & Recreation Department.

Attached: Date Ranges, Specifications & Examples, and Application Forms

2020 Date Ranges: Standard: Monday-Monday for 3 weeks

Monday holiday= Tuesday installation.

Advert. Session #	Installation	Removal
1	12/30/19	01/21/20
2	01/21/20	02/10/20
3	02/10/20	03/02/20
4	03/02/20	03/23/20
5	03/23/20	04/13/20
6	04/13/20	05/04/20
7	05/04/20	05/26/20
8	05/26/20	06/15/20
9	06/15/20	07/06/20
10	07/06/20	07/27/20
11	07/27/20	08/17/20
12	08/17/20	09/08/20
13	09/08/20	09/28/20
14	09/28/20	10/19/20
15	10/19/20	11/09/20
16	11/09/20	11/30/20
17	11/30/20	12/28/20

2020 Requests are accepted **Oct. 1, 2019 by email** on first come, first serve basis.

Email completed forms to Ashley Howe, Ashley.howe@cityofsanrafael.org

SPECIFICATIONS & EXAMPLES- POLE BANNERS page of 1

Please list pole #s in your request or attach the 2020- **Banner Location Template**.

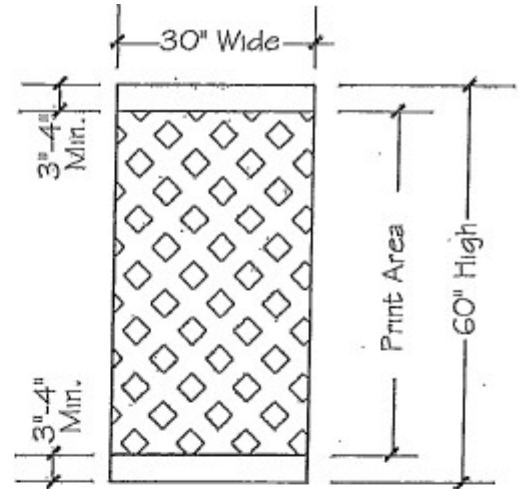

Banner Detail

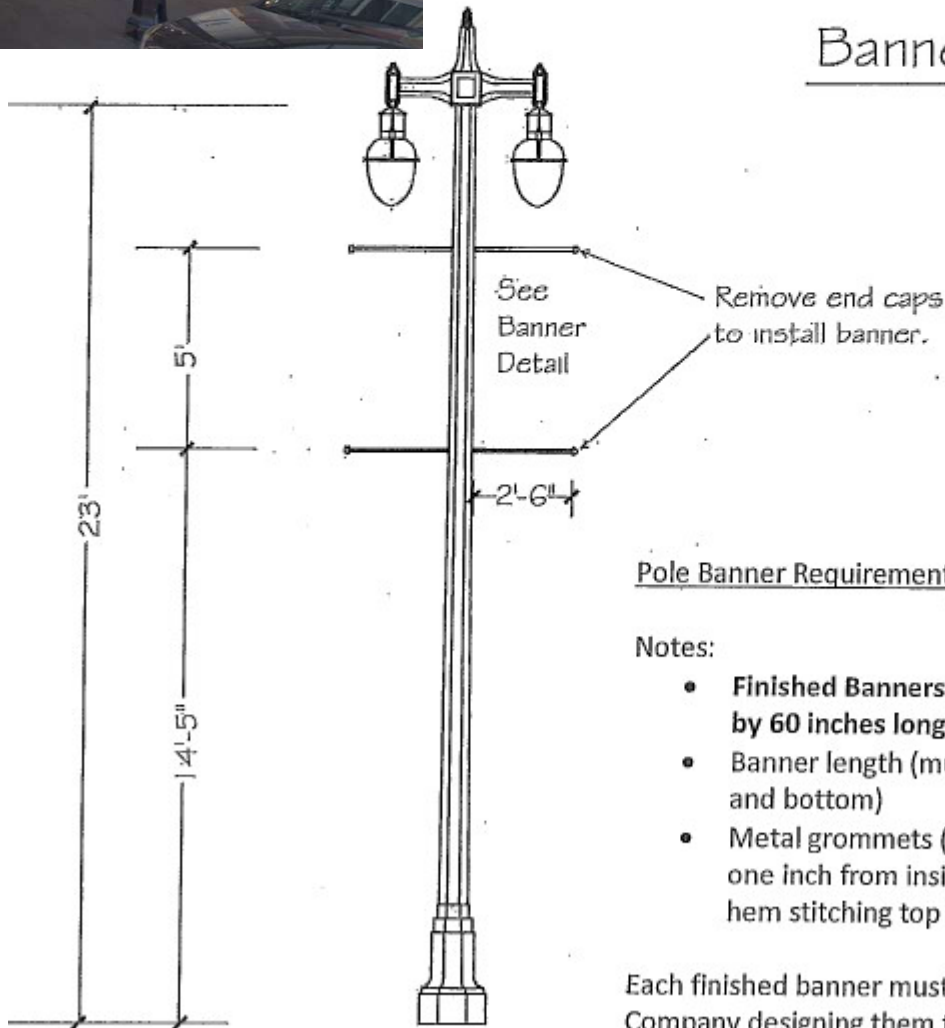

Pole Banner Requirements

Notes:

- **Finished Banners must measure 30 inches wide by 60 inches long**
- Banner length (must include 4 inch hems top and bottom)
- Metal grommets (1/2" in size) must be placed one inch from inside edge (pole side) close to hem stitching top and bottom

Each finished banner must be measured by the Company designing them to ensure size and design requirements are met. Banners not made to specification will not be hung.

SPECIFICATIONS & EXAMPLES- ACROSS STREET BANNERS page 1 of 2

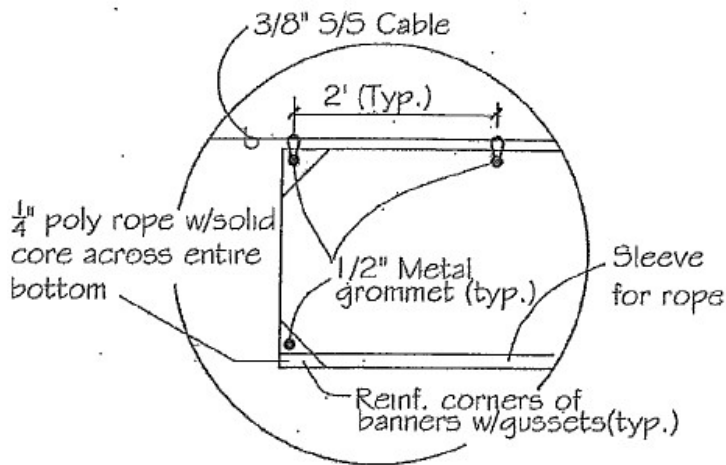
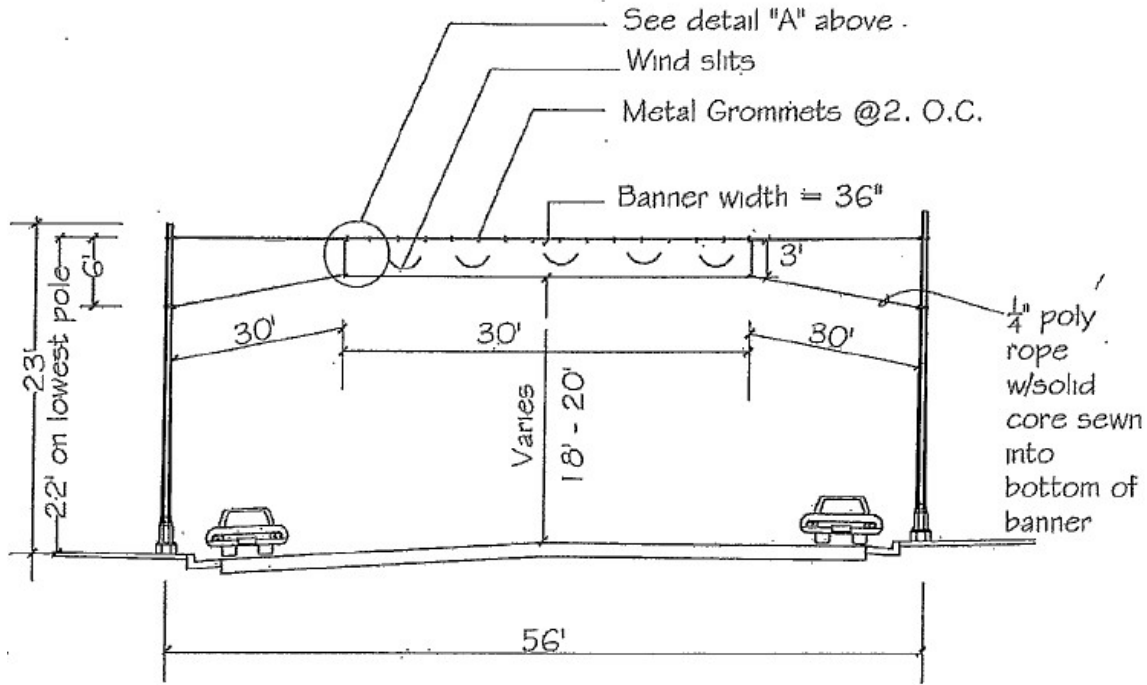

DETAIL A

"EAST END"- 4th Street at Tamalpais Ave.

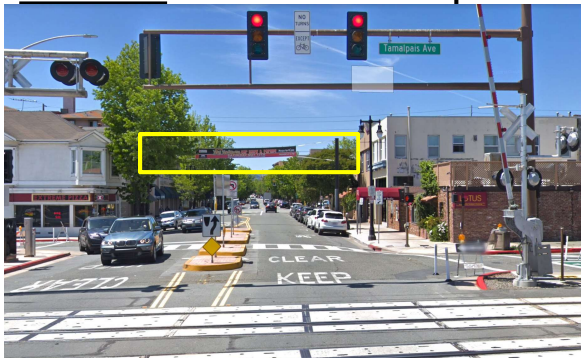

"WEST END"- 4th Street at 2nd Street (Merge)



SPECIFICATIONS & EXAMPLES- ACROSS STREET BANNERS page 2 of 2

Banner shall be 30 feet in length and 36 inches wide, with reinforced corners, grommets across the top, and rope sewn into the bottom.

Metal Grommets. Install grommets in all four corners of banner, then place a $\frac{1}{2}$ " size metal grommet every 2 feet on the top of the banner. (18 total grommet holes across top, spaced every 2 feet).

Wind Slits. The banner must be made of a sturdy material with holes cut in it for the wind to flow through. The recommendation is 7" flaps placed at least every 4 feet. If smaller flaps are necessary to avoid writing or graphics, then more flaps should be used. Less wind resistance means less stress on the banner.

Reinforcing. Reinforce banner with double gussets (to achieve triple thickness) at all 4 corners. This is where most banners fail, so sufficient reinforcement will help prevent tearing and make the banner last longer.

Ropes. $\frac{1}{4}$ " poly rope with a solid core should be sewn into a sleeve along the bottom of the banner, with 30 feet of excess rope extending on both sides (total length of bottom rope should be 90 feet). Secure the bottom rope to the banner to prevent sliding.

All banners must be ready to hang with all rope included. Installers will attach clips.

A banner not properly prepared will not be hung until corrected by the applicant.

Banner text, materials and colors shall be reviewed and approved by the City before installation.

TIP: It is VERY important to include a **well-secured/sewn in rope along the bottom** of the banner. The West End location can be particularly windy.