

RAISED CROSSWALK DETAIL

NOT TO SCALE

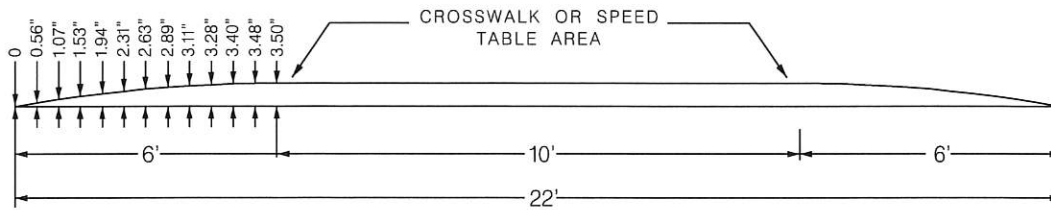

SECTION A-A

NOT TO SCALE

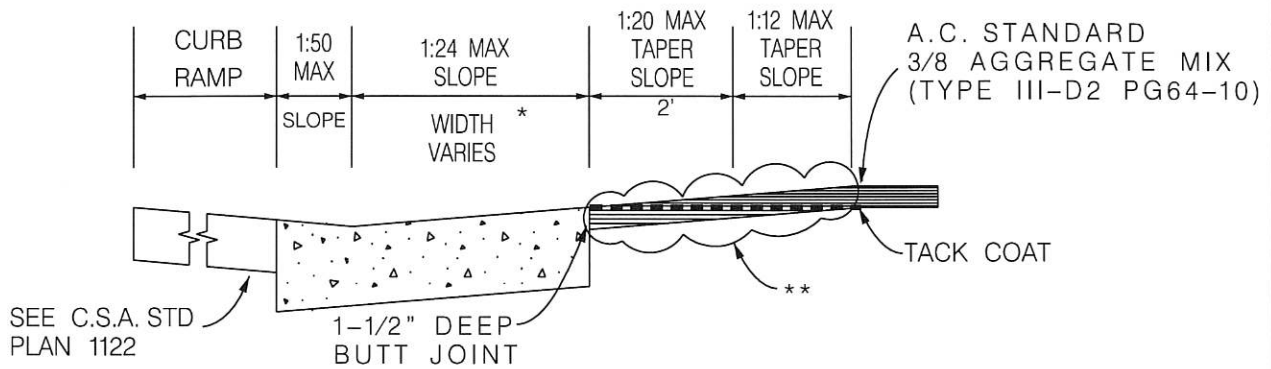

SECTION B-B

NOT TO SCALE

- * IF THERE IS NO ACTUAL GUTTER USE 2 FEET
- ** OR CONCRETE IF SPECIFIED

THIS STANDARD TO BE USED ONLY ON STREETS WIDER THAN OR EQUAL TO 36 FEET.

APPROVED:  DATE: 5/31/23
CITY ENGINEER

CITY OF SANTA ANA
PUBLIC WORKS AGENCY



DATE	REVISION
4/26/07	Z.K. REVISED PROFILE
8/30/16	MMS UPDATED STANDARD PLAN
5/25/23	AD UPDATED STANDARD PLAN

RAISED CROSSWALK

STD. PLAN NUMBER
1131A
SHT. 1 OF 2

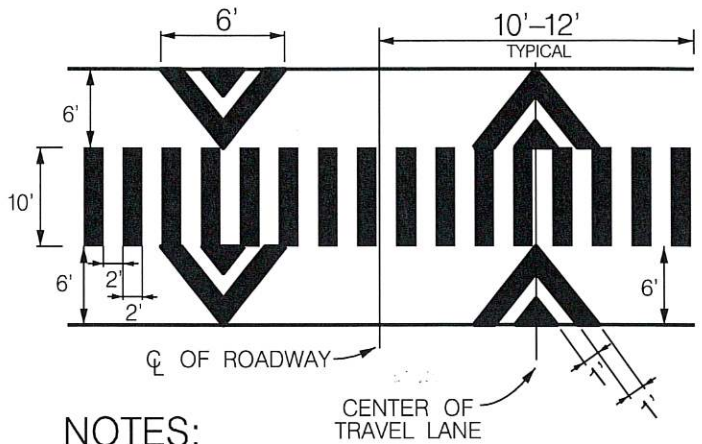
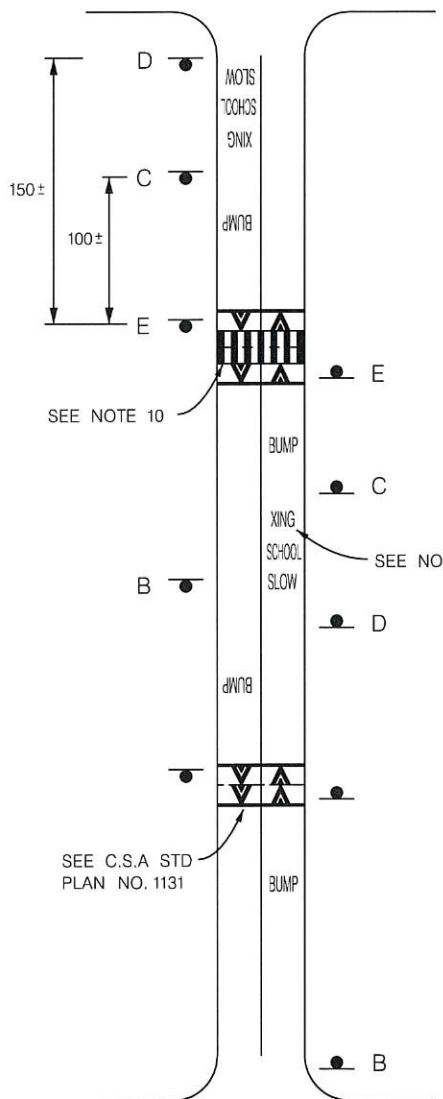

NOTES:

1. "SLOW SCHOOL XING" ADVANCE SCHOOL CROSSWALK LEGEND SHALL BE USED AT YELLOW SCHOOL CROSSWALKS.
2. EXACT LOCATIONS OF RAISED CROSSWALK, SIGNS AND MARKINGS, SHALL BE DETERMINED BY THE CITY ENGINEER.
3. WHERE POSSIBLE RAISED CROSSWALK SHOULD BE 150 FEET CLEAR OF STOP SIGNS.
4. WHERE POSSIBLE RAISED CROSSWALK SHOULD BE DOWN STREAM OF STORM DRAIN INLETS.
5. RAISED CROSSWALK SHALL NOT BE PLACED ON SHARP HORIZONTAL OR VERTICAL CURVES.
6. APPROPRIATE ADVANCE CROSSWALK LEGENDS SHOULD BE USED, EITHER 'SLOW SCHOOL XING' OR 'PED XING'.
7. AT RAISED CROSSWALKS, SIGN C SHALL BE USED TO COMMUNICATE THAT THE ROAD IS BOTH RAISED AND A CROSSWALK IS PRESENT.
8. FOR SIGN D AND SIGN E, USE APPROPRIATE W11-2, W11-15 OR W11-1 SIGN IF NOT AT A SCHOOL CROSSWALK.
9. USE APPROPRIATE TYPE OF WHEELCHAIR RAMP PER C.S.A. STD 1122 DEPENDING ON WHETHER IT IS MIDBLOCK OR AT AN INTERSECTION.
10. INSTALL CONTINENTAL CROSSWALK WHITE UNLESS NOTED OTHERWISE.

SIGNING AND MARKINGS

 SPEED BUMP 15 MPH SIGN B	W17-1 30"X30" W13-1P (15) 18"X18"	 SPEED BUMPS AHEAD 15 MPH SIGN B (MOD)	W17-1 (MOD2) 30"X30" W13-1P (15) 18"X18"	 RAISED CROSSWALK AHEAD 15 MPH SIGN C	SPECIAL 6" SERIES E LETTERS 30"X30" W13-1P (15) 18"X18"	 SIGN D	S1-1 (OR W11-2, W11-15, OR W11-1) 36"X36" W16-9P 24"X12"	 SIGN E	S1-1 (OR W11-2, W11-15, OR W11-1) 36"X36" W16-7P 24"X12"
------------------------------------	--	---	---	--	--	------------	---	------------	---

NOT TO SCALE

APPROVED:
DATE: 5/31/23
CITY ENGINEER

CITY OF SANTA ANA
PUBLIC WORKS AGENCY



DATE	REVISION
4/26/07	Z.K. UPDATED CHEVRONS
8/30/16	MMS UPDATED STANDARD PLAN
5/25/23	RJA UPDATED STANDARD PLAN

RAISED CROSSWALK

STD. PLAN NUMBER
1131A
SHT. 2 OF 2