

LOADING SPACE REQUIREMENTS

Every building involving the receipt or distribution by vehicle of materials or merchandise incidental to carrying on such activity shall be provided with at least one (1) space for standing, loading and unloading of vehicles to avoid undue interference with the public use of on-site travel aisles, streets and alleys. Such space shall be provided at a size sufficient to accommodate the largest delivery vehicle likely for the building and in no case be less than ten (10) feet by twenty-five (25) feet. Loading zones shall be provided at a rate of one (1) for every ten thousand (10,000) square feet of floor area or outdoor storage area. A fourteen-foot minimum height clearance shall be maintained. Loading zones shall not interfere with or be used for off-street parking purposes. Loading zones shall be clearly designated and labeled, and may not be located adjacent to property used or zoned for residential purposes. Sec. 41-1305.

PARKING LOT DESIGN

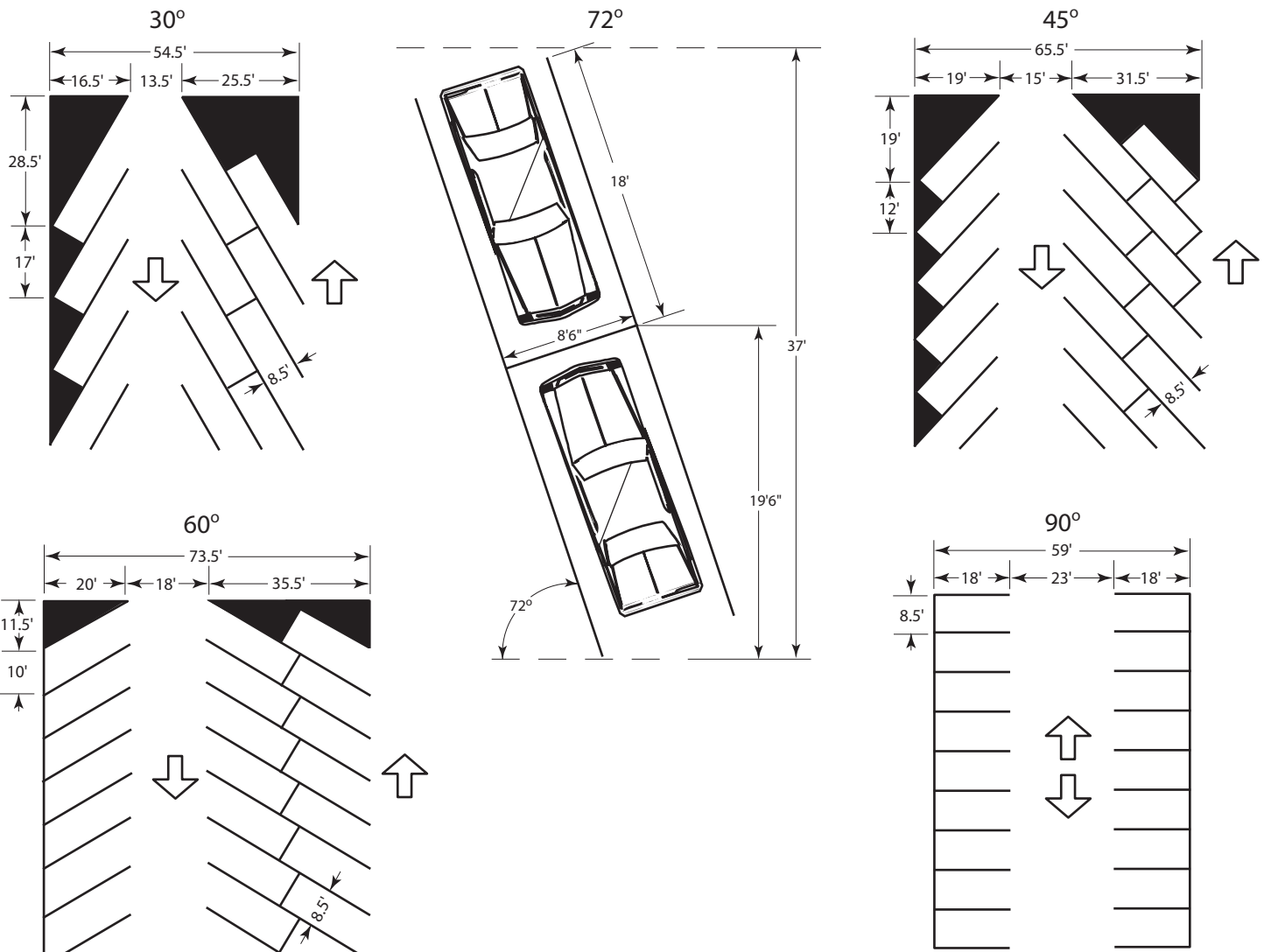

(Except stalls are adjacent to a wall or fence shall be 9 feet wide)

Landscaping (Example Only)

NOTE: All Dimensions are Approximate ONLY.

PARALLEL PARKING

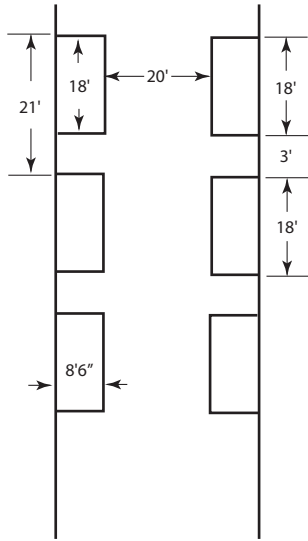

DRIVEWAY WIDTHS

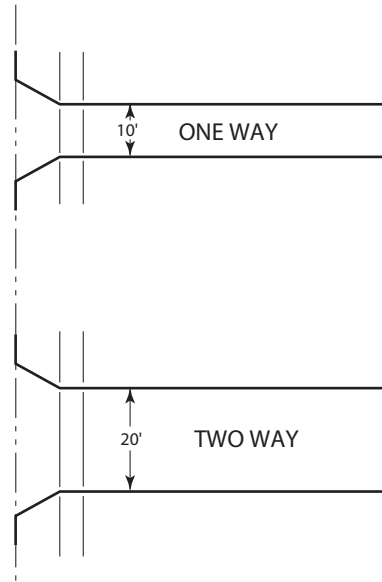

PARKING LOT LANDSCAPE PLANTER DETAIL

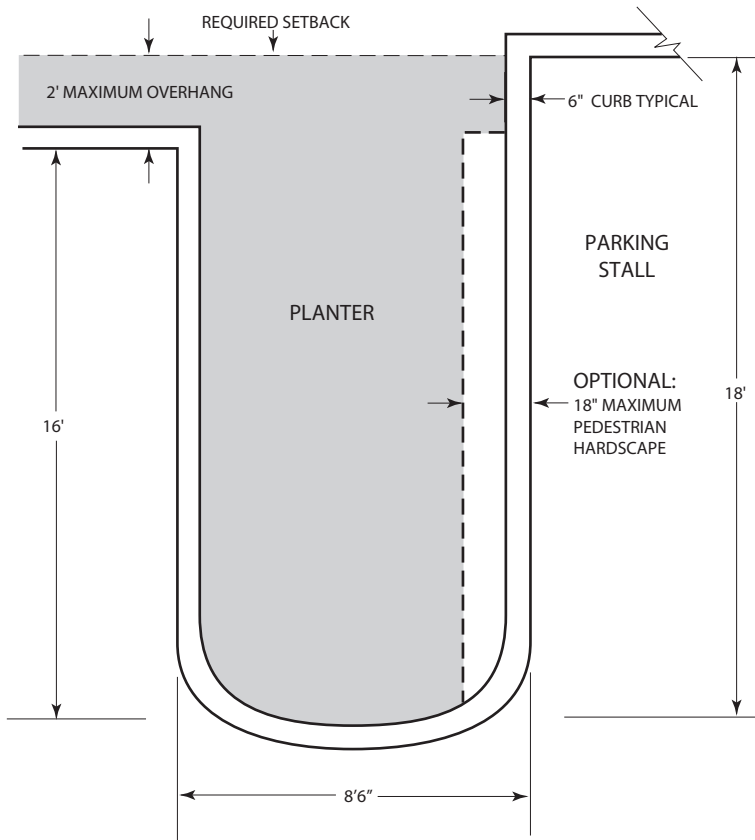

PARKING LOT STRIPING

