

# SANTA ANA POLICE DEPARTMENT

DAVID VALENTIN · CHIEF OF POLICE

## TRAINING BULLETIN

*"Education promotes professional and responsive law enforcement"*

### Tracking Devices

#### Purpose

The purpose of this Training Bulletin is to familiarize our personnel with the electronic tracking devices, which are currently being used to assist in recovering stolen property and the apprehension of suspects. The technology of electronic devices is constantly changing and our monitoring and use of the devices will certainly increase over the coming years.

#### I. Electronic Tracking Devices

There are four tracking systems that will be discussed and officers/dispatchers should be familiar with their operation. Three of the devices are used specifically for recovery of stolen vehicles and possible arrest of the suspects. The other system is for recovery of stolen property and is generally used by banking institutions and jewelry stores. All four of the tracking systems are sold to the users by private companies. Even though these systems are very reliable, the officers should take into consideration the possibility of errors when tracking a signal. A vehicle incorrectly entered in the SVS system, or not removed after being recovered, or a jewelry store employee accidentally activating a signal are all examples of errors that may occur. Officers must remember this when responding to or tracking a signal.

#### II. LoJack Vehicle Recovery System

The LoJack system is typically sold to a consumer at the time they purchase a new vehicle, but an authorized dealer may also install it post-purchase.

The LoJack system works as follows:

1. A transponder is installed in the consumer's vehicle.
2. A consumer's vehicle is stolen.
3. The consumer reports their vehicle stolen to a police agency.
4. When the vehicle's VIN # is entered into the stolen vehicle system by the reporting agency the SVS computer system automatically activates the LoJack system in the stolen vehicle.
5. A police unit with LoJack tracking picks up the signal from the stolen vehicle and a LoJack reply code is displayed.
6. The officer advises communications of the reply code received on their display.

7. The officer with the help of other trackers locates the vehicle and makes a recovery and/or arrest.
8. The officer fills out a CLETS recovery entry form, which deactivates the LoJack signal when it is entered into the statewide computer system.

Police units with LoJack capabilities are easily identifiable by the four antennas on the roof of the unit, in addition to the standard police radio antenna. There will also be a display device on the dashboard of the vehicle.

### III. Operation of the Police Tracking Computer (PTC)

#### A. Checkout Procedure (Beginning of Shift)

1. With ignition off, push the rocker switch to “*lock*” position.
2. Turn the ignition on, the PTC will go through a self diagnostic mode displaying all of the LED lights and the test numbers.
3. Push the rocker switch to “*unlock*”, and the unit is now in the patrol mode.

#### B. Patrol Mode

1. Leave the PTC in the “**UNLOCK**” position until receiving a LoJack activation.
2. Occasional frequency interference will cause the display to show a series of dashes and may chirp. This is not stolen vehicle activation.
3. Occasionally training may be performed by SAPD or neighboring cities. The PTC will display three O's followed by two other digits (ooo\*\*), this signifies a test unit, but should you have a question, ask.

#### C. Receiving Activation Signal

1. An audible tone will be heard as the first indication that you are in range of a stolen vehicle whose LoJack transponder has been activated.
2. Look for a five-digit LoJack number on the display.  
Push the rocker switch to the “**LOCK**” position, this will lock in that number and ignore any other signal.
3. Advise communications of the five-digit number and they will be able to advise you of any information on the stolen vehicle CLETS (i.e. make, model, color, license).
4. When an inquiry is made the signal will update once every second, for thirty minutes. If a recovery is not made within thirty minutes you must request a re-run of the LoJack number to maintain your one per second updates.

#### D. Tracking Mode

1. The directional indicator is on the right side of display head and indicates the relative direction of the stolen vehicle in relationship to the unit.
2. Start driving in the direction of the signal. As the stolen vehicle gets closer the "local" phase of signal strength will activate.
3. The signal may be affected by buildings, walls, or other objects, causing a bouncing-effect.
4. If you are receiving a bouncing effect, stop for 5 -10 seconds in an intersection to stabilize the signal.
5. Do not execute a turning movement until the indicator is consistently at the 9 O'clock or 3 O'clock position.
6. The signal-strength indicator is located on the left side of the display head and indicates the relative distance between the vehicle and the unit.
7. There are two levels of signal strength. When the "local" light is off, the vehicle is more than a half mile away and when the "local" light is on, the vehicle is less than a half mile away. **NOTE: TERRAIN AND BUILDINGS WILL AFFECT SIGNAL STRENGTH.**
8. There will be 10 bars of strength before the "local" light comes on and it is common to go between 10 bars "Non-local" and 2 bars "local".
9. Locating of the stolen vehicle is facilitated by the use of two or more trackers. It is very important to communicate with other LoJack equipped units in order to pinpoint the stolen vehicle by triangulation.
10. There is no need to even look for the vehicle until you have a "local", 6-7 bars reading.
11. When the vehicle is recovered, remember to remove it from the computer immediately to prevent other units from tracking the recovered vehicle. **Do not release the vehicle to anyone (registered owner, tow truck impound yard, etc.) until the vehicle has been removed from the SVS system and the LoJack signal has been deactivated.**

## E. Using the Units KDT to Access the Stolen Vehicle Recovery Network

1. All SAPD-KDT units will have the capability of accessing the Stolen Vehicle Recovery Network (SVRN) LoJack reply code number via their unit Key Digital Terminals.
2. **Operational Instructions** - On a blank screen type "QLJ\_\_\_\_\_" (insert a space - followed by the five-digit LoJack reply code number appearing on LoJack tracking computer screen).
  - a. **Example:** QLJ\_T36E3 <SEND>.

The System will return with a vehicle description and stolen agency information from statewide stolen vehicle system (SVS) computer.

**NOTE:** When any agency runs the LoJack (SVRN) number, the SVRN computers will automatically increase the "beep" tones (heard by a field officer's LoJack tracking device) to one second intervals (making the tracking procedure much easier). This "speed-up" phase will last for 30 minutes from the time the last agency ran the

LoJack number. Should the field officer require another 30 minute “*speed-up*” phase, simply re-run the LoJack number.

3. **Training Units** - Training units have been assigned to law enforcement agencies and LoJack Corporation to allow field training and demonstration of the system. These training units transmit a “000 “ number (example: 000U4) on the officers LoJack tracking screen. If you “run” a 000 number, it will return with “*No tracking required for type 000*”.
4. **Test Numbers** - For training purposes (*or to test system*), you may run T36E3 which will return as an outstanding LAPD stolen.  
**Note** - this is a “*live*” record.

## F. Dispatcher Obtaining LoJack Verification Information

1. AD LoJack-equipped vehicles, when activated, will transmit a silent signal, which will display a five digit number on the LoJack tracking screen of the patrol officer's vehicle. When a field officer advises of receiving a LoJack activation, our dispatch shall do the following:
  - a. Obtain the five-digit LoJack (SVRN) number.
  - b. On a blank screen type (*insert a space-followed by the five digit LoJack number*).

i. **Example:** QLJ T36E3 <Enter>.

- c. The System will return with the full vehicle description and stolen information data plus any miscellaneous and “*Caution Code*” data entered by the original stolen agency. When any agency runs the LoJack (SVRN) number, the SVRN computers will automatically increase the “*beep*” tones (*heard by field officer's LoJack tracking devices*) to one-second intervals (*making tracking procedure much easier*). This “*speed-up*” phase will last for 30 minutes from the time the last agency ran the LoJack number. Should the field officer require another 30 minute “*speed-up*” phase, simply re-run that number.
2. If CLETS or other DOJ computers are “*down*” the SVRN (*LoJack*) computer will also be down. If only the SVRN computer is “*down*” you will either get no response or get a return of “*SVRN busy*”. Call LoJack offices at **310-286-2610** (*24 hr*).
3. **Training Units** - Numerous training units have been assigned to law enforcement agencies and LoJack Corporation to allow field training and demonstration on the system. These training units transmit a “000“ number (*Example: 000U4*) on the officers LoJack tracking screen. If you run a “000-“ number it will return with “*No tracking required for type 000*”.
4. **Test Numbers** - For training purposes (*or to test system*), you may run T36E3 which will return as an outstanding LAPD, stolen.  
**Note** - This is a “*live*” record.

## IV. On-Star Vehicle Recovery System

The On-Star vehicle recovery system is sold to the consumer at the time of purchase of a new vehicle on selected GM model vehicles. The consumer pays a monthly or annual subscription

fee for monitoring services. On-Star offers a variety of services including a “panic alarm” feature for general emergencies as well stolen vehicle tracking and recovery services. These two types of On-Star activations will be the types most commonly encountered by law enforcement officers. On-Star does not rely on, or require, tracking equipment in police units. On-Star representatives track the signal using GPS and cellular antennas. The information is relayed to local police dispatch centers, which in turn relay the information to units in the area. The system works as follows:

1. The consumer purchases a vehicle equipped with On-Star and pays the annual service fee.
2. The vehicle is stolen.
3. The victim calls On-Star and reports the vehicle as stolen. On-Star will begin tracking and monitoring the vehicle. On-Star will direct the subscriber to notify the local police, report the vehicle stolen and obtain a case number.
4. Once On-Star has received the case number they will contact the local police dispatch in the area the vehicle is located and provide the vehicle location, speed, direction of travel etc.
5. Dispatch will notify police units in the vicinity who will attempt to intercept and locate the vehicle.
6. If the vehicle is stationary, accuracy is approximately 100 feet. If the vehicle is mobile you need to account for the lag time between On-Star notification to dispatch and dispatch notification to the units. Experience has shown that at 40 mph the vehicle is usually  $\frac{1}{4}$  to  $\frac{1}{2}$  mile ahead of the location given.
7. Once the vehicle is located dispatch will notify On-Star who will cease tracking the vehicle. The officer still needs to complete a recovery report and remove the vehicle from CLETS prior to releasing the vehicle.

## V. Teletrac Vehicle Recovery System

The Teletrac system is also sold to the consumer at the time of purchase of a new vehicle or installed by an authorized teletrac dealer. The consumer pays for the initial installation and in addition pays a monthly monitoring fee. This system works differently than a LoJack tracker. It does not require a tracking police unit to be in the area and also provides roadside assistance and locating capabilities for the consumer. Two plans are offered for vehicle recovery. One requires that the victim notify Teletrac that the vehicle is missing and one automatically activates the signal when the vehicle's ignition is bypassed. It works as follows:

1. A transponder is installed in the consumer's vehicle.
2. The vehicle is stolen.
3. The consumer reports their vehicle stolen to a police dept.
4. Depending on the type of plan, the vehicle is either called in to Teletrac as stolen or is automatically activated when the ignition is bypassed.
5. Teletrac or Control One (*Orange County*) will notify an agency that the stolen vehicle is in their jurisdiction. Control One has a Teletrac monitor screen and will go to “Red” channel and notify all agencies. Teletrac may call the individual agency or Control One or both.

6. Patrol units will be notified of the vehicles location (*within 100 ft*), they will also be given a direction of travel and location update every 10 seconds.
7. Upon recovery of this vehicle the officer must notify Control One that the vehicle has been recovered and remove the vehicle from CLETS. Do not release the vehicle to anyone until it has been cleared from the system as stolen and the Teletrac signal is no longer active. This system is valid for Los Angeles, Orange, Riverside and San Bernardino Counties.

## VI. Pronet Tracking Devices

The Pronet Tracking Devices is the new name for the ETS (*Electronic Tracking System*) that has been utilized to track currency/property from member businesses. The original system was implemented to combat a growing bank robbery problem in the Southern United States and has now been expanded to include most of the large metropolitan areas. The system works by using a small transmitter, which is hidden, either in a money pack or in boxes of jewelry. The banking institution/business pays a monthly fee to use the transmitters (*tags*). The tag is placed on a magnetic type pad until removed during a robbery, and when removed the transmission of a tracking signal is initiated. The new version of the tracking system will have fewer false activations (*i.e. from engines starting, radio transmissions*). It also will provide Control One with a close approximate area of where the tag is located. Other features provide a tone change to tell an officer when the tag is directly in front or off to an angle from the front of the unit. *The step by step system works as follows:*

1. A transmitter (*tag*) is purchased by the bank or business.
2. The tag is placed in money/valuable property.
3. Upon business being robbed the tag is given with the money or property.
4. Control One or a Tracker equipped patrol unit receives a signal. Control One will wait 20seconds for a possible error factor, however, a unit might be in the immediate area at the time of the activation.
5. Control One will then announce "*Code Echo Activation*" and will give the approximate location of the tag.
6. Units equipped with tracking systems shall respond to the area and start tracking the signal.
7. Upon locating the transmitter disable it by using a magnetic type pad in the trunk of the equipped unit.

Police units with the tracking system are easily identifiable by the three antennas on the roof of the unit and a display on the upper dashboard of the unit.

### A. Operation of the Pronet Tracking System

1. When the ignition on the unit is turned on the Display will go through a self-test to verify that all lights on the display are working and the display is plugged into a receiver.
2. Upon leaving the station the officer should verify that the adjustment on the receiver is correct, by checking the position on the display, verifying that it points

towards the West side of the Police building where a test transmitter is installed. The officer should sign on with the suffix "T" to signify that he is a tracker unit.

3. While on patrol there may be some false signals from non-tag sources. This should be only for a short period and go away within a half a block. A sustained signal should only come from a "tag".
4. If while on patrol an officer receives a strong signal and if it is coming from a specific location, they should immediately contact communications and advise of the activation. Even though this may be an accidental activation, they should take the appropriate action.
5. Usually, the activation will be picked up by Control One and broadcast over Red channel as a "Code Echo." The tracking officer should proceed toward the signal location and wait for further information about the robbery and then begin tracking the signal.
6. Upon receiving a strong signal activation in your unit, notify Communications and also Control One via Red channel your location, the direction of the signal and the strength in order to advise other nearby jurisdictions.

## B. Tracking Using the Pronet System

1. The dash display is similar to a LoJack tracker because it will also give a direction and a signal strength indication.
2. The direction is relative to the front of the unit, and the half circle of lights represents a 240 degree arch centered on the front of the unit.
3. As with the vehicle locating system, this signal can also be hindered by buildings, walls and overpasses, causing a bouncing effect.
4. The signal strength indicator will display 0 to 12 bars, which vary with the strength of the signal. A indication of 10 to 12 bars would mean that the signal transmitter should be within sight of the tracking officer, and he must remember that the tags are very small and can be hidden inside a bag, purse, pocket, briefcase or vehicle.
5. Track the transmitter signal until it is narrowed down to a single person, car, package, building, etc.

## C. Hand Held Tracking Unit

1. Each equipped tracking unit should have a hand held tracker in the trunk. This is slightly larger than a pager and has an antenna.
2. Once the tag has been located and is not accessible to a tracking unit, the search can be narrowed down using the hand held tracker.
3. Start using the hand held tracker with the antenna fully extended and lower the antenna as you get closer to the tag. Remember to use all officer safety tactics and this tracking should not be conducted alone.

## D. New Tracker Display Unit

The new tracker display unit has revisions, which will assist the field officer more than that of the first generation display unit. These features include:

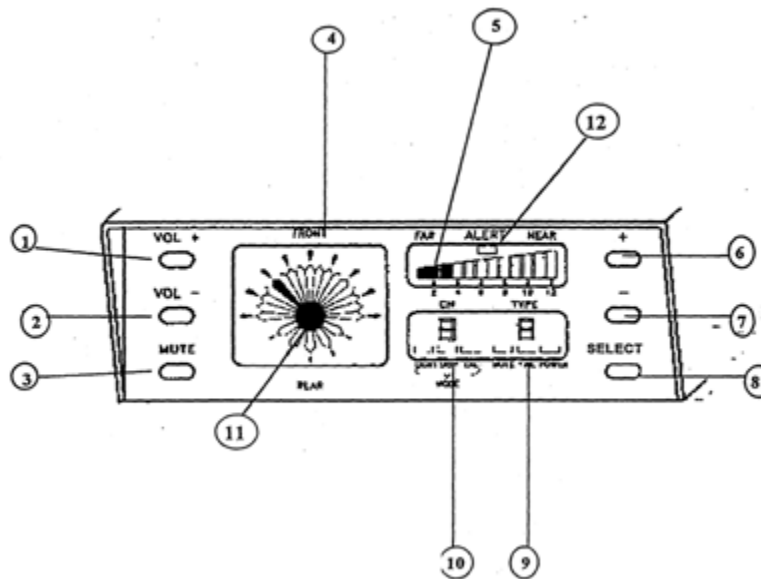

1. Volume up control, to adjust the volume of the tone.
2. Volume down control to adjust the volume of the tone.
3. Volume mute control, to silence the tone.
4. Directional display based on a digital signal, for better reliability.
5. Signal strength display, also based on digital signal for reliability.
6. Backlight + and Mode + change.
7. Backlight - and Mode - change.
8. Mode Select control, to allow for training purposes.
9. Tag signal being received, at this point "F" only for "*financial*".
10. Operating channel display (S)tandard, (U)ndercover, and (P)ractice.
11. RF signal lock when center dot is displayed, signifying unit has locked in on a tag.
12. Signal alert indication, signifying that the receiver is getting wave signals.

## E. Use of Electronic Tag By Investigation

The Pronet Co. has given us a tag, which may be used at our discretion at locations where repeat crimes or predicted crimes may occur. This tag is to be used by Investigations and is meant for only short periods of time, since we are not being charged for the tag. There is a sign out sheet for the tag, and should be signed out with CDC or the SAPD Liaison for the Pronet Co. Training of Officers

All field officers will be given a presentation by videotape on the new system and most will be given a field refresher course in tracking of the tags. A copy of the videotape will also be available in Training for officers to review.



## F. Problems With Tracking Units

1. Any problems with a tracking unit should be pointed out to an authorized ETS instructor as listed on the roll call room bulletin board.
2. We have more units wired for the ETS system than the actual systems in our possession, but should your unit not have a dash display, you can check with the listed instructors to see if additional equipment is available.

## Conclusion

Electronic tracking devices are becoming more advanced and are providing Law Enforcement, an opportunity to have a positive impact on certain crimes. The four electronic tracking systems we currently have available to us are extremely beneficial. They have resulted in numerous arrests and the recovery of large amounts of stolen property. As more advances in technology are made, it is likely we will have a large variety of electronic equipment that will help Law Enforcement be even more effective.

**Acknowledgment:** This training bulletin was researched and revised by Corporal C.L. Jarusek 5/98

**Revised By:** Corporal Jeff Van Es

**Revision Date:** November 2006