

APPENDIX B

EXISTING TRAFFIC COUNT DATA

APPENDIX B-1

EXISTING INTERSECTION TRAFFIC COUNT DATA

City: SANTA ANA
 N-S Direction: I-5 SB ON RAMP
 E-W Direction: 1ST STREET

File Name : H1610020
 Site Code : 00000000
 Start Date : 10/5/2016
 Page No : 1

Groups Printed- Turning Movements

Start Time	DEAD END Southbound			1ST STREET Westbound			I-5 SB ON RAMP Northbound			1ST STREET Eastbound			Int. Total
	Right	Thru	Left	Right	Thru	Left	Right	Thru	Left	Right	Thru	Left	
07:00	0	0	0	0	118	64	0	0	0	268	169	0	619
07:15	0	0	0	0	136	87	0	0	0	254	172	0	649
07:30	0	0	0	0	189	112	0	0	0	226	163	0	690
07:45	0	0	0	0	202	84	0	0	0	235	178	0	699
Total	0	0	0	0	645	347	0	0	0	983	682	0	2657
08:00	0	0	0	0	185	70	0	0	0	218	220	0	693
08:15	0	0	0	0	174	52	0	0	0	176	227	0	629
08:30	0	0	0	0	150	57	0	0	0	189	196	0	592
08:45	0	0	0	0	133	50	0	0	0	209	247	0	639
Total	0	0	0	0	642	229	0	0	0	792	890	0	2553
16:00	0	0	0	0	197	45	0	0	0	220	341	0	803
16:15	0	0	0	0	176	45	0	0	0	208	344	0	773
16:30	0	0	0	0	191	60	0	0	0	235	334	0	820
16:45	0	0	0	0	171	50	0	0	0	231	334	0	786
Total	0	0	0	0	735	200	0	0	0	894	1353	0	3182
17:00	0	0	0	0	218	91	0	0	0	207	320	0	836
17:15	0	0	0	0	193	64	0	0	0	232	326	0	815
17:30	0	0	0	0	170	82	0	0	0	199	360	0	811
17:45	0	0	0	0	186	46	0	0	0	197	366	0	795
Total	0	0	0	0	767	283	0	0	0	835	1372	0	3257
Grand Total	0	0	0	0	2789	1059	0	0	0	3504	4297	0	11649
Apprch %	0	0	0	0	72.5	27.5	0	0	0	44.9	55.1	0	
Total %	0	0	0	0	23.9	9.1	0	0	0	30.1	36.9	0	

Start Time	DEAD END Southbound				1ST STREET Westbound				I-5 SB ON RAMP Northbound				1ST STREET Eastbound				Int. Total
	Right	Thru	Left	App. Total	Right	Thru	Left	App. Total	Right	Thru	Left	App. Total	Right	Thru	Left	App. Total	
Peak Hour Analysis From 07:00 to 08:45 - Peak 1 of 1																	
Peak Hour for Entire Intersection Begins at 07:15																	
07:15	0	0	0	0	0	136	87	223	0	0	0	0	254	172	0	426	649
07:30	0	0	0	0	0	189	112	301	0	0	0	0	226	163	0	389	690
07:45	0	0	0	0	0	202	84	286	0	0	0	0	235	178	0	413	699
08:00	0	0	0	0	0	185	70	255	0	0	0	0	218	220	0	438	693
Total Volume	0	0	0	0	0	712	353	1065	0	0	0	0	933	733	0	1666	2731
% App. Total	0	0	0	0	0	66.9	33.1		0	0	0	0	56	44	0		
PHF	.000	.000	.000	.000	.000	.881	.788	.885	.000	.000	.000	.000	.918	.833	.000	.951	.977

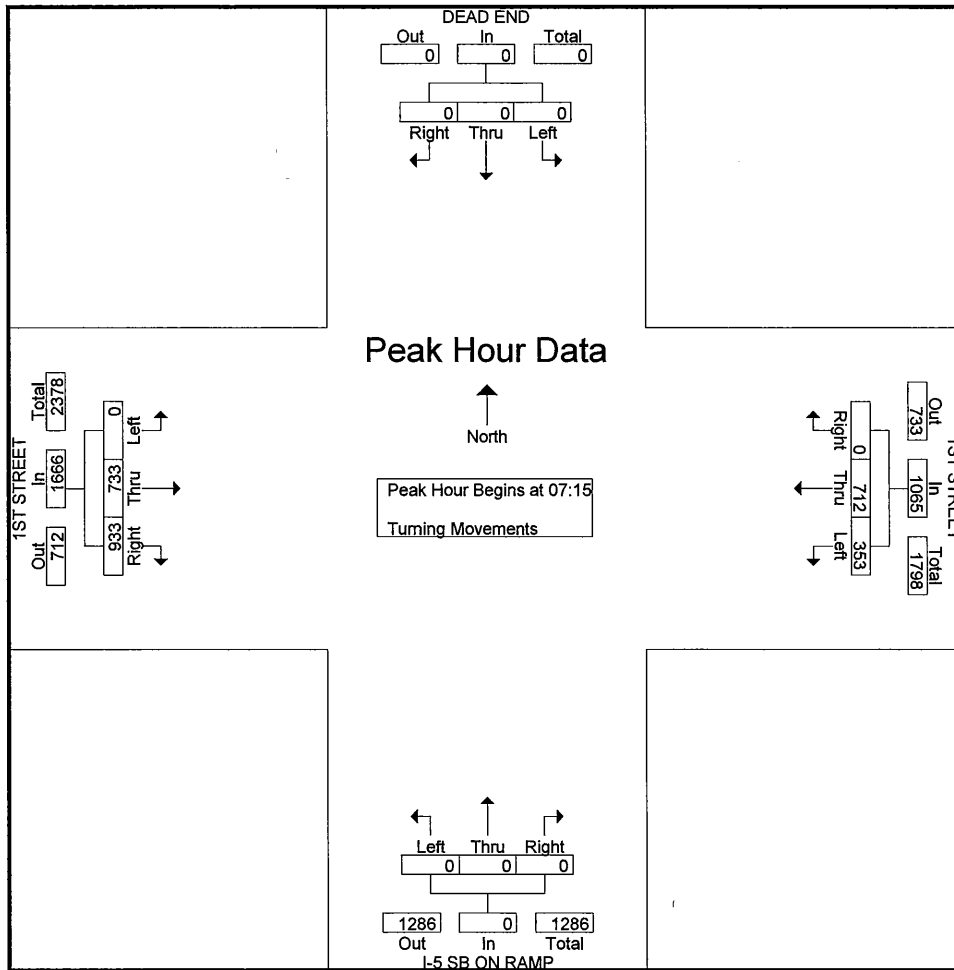

Start Time	DEAD END Southbound				1ST STREET Westbound				I-5 SB ON RAMP Northbound				1ST STREET Eastbound				Int. Total
	Right	Thru	Left	App. Total	Right	Thru	Left	App. Total	Right	Thru	Left	App. Total	Right	Thru	Left	App. Total	
Peak Hour Analysis From 16:00 to 17:45 - Peak 1 of 1																	
Peak Hour for Entire Intersection Begins at 16:30																	
16:30	0	0	0	0	0	191	60	251	0	0	0	0	235	334	0	569	820
16:45	0	0	0	0	0	171	50	221	0	0	0	0	231	334	0	565	786
17:00	0	0	0	0	0	218	91	309	0	0	0	0	207	320	0	527	836
17:15	0	0	0	0	0	193	64	257	0	0	0	0	232	326	0	558	815
Total Volume	0	0	0	0	0	773	265	1038	0	0	0	0	905	1314	0	2219	3257
% App. Total	0	0	0	0	0	74.5	25.5		0	0	0	0	40.8	59.2	0		
PHF	.000	.000	.000	.000	.000	.886	.728	.840	.000	.000	.000	.000	.963	.984	.000	.975	.974

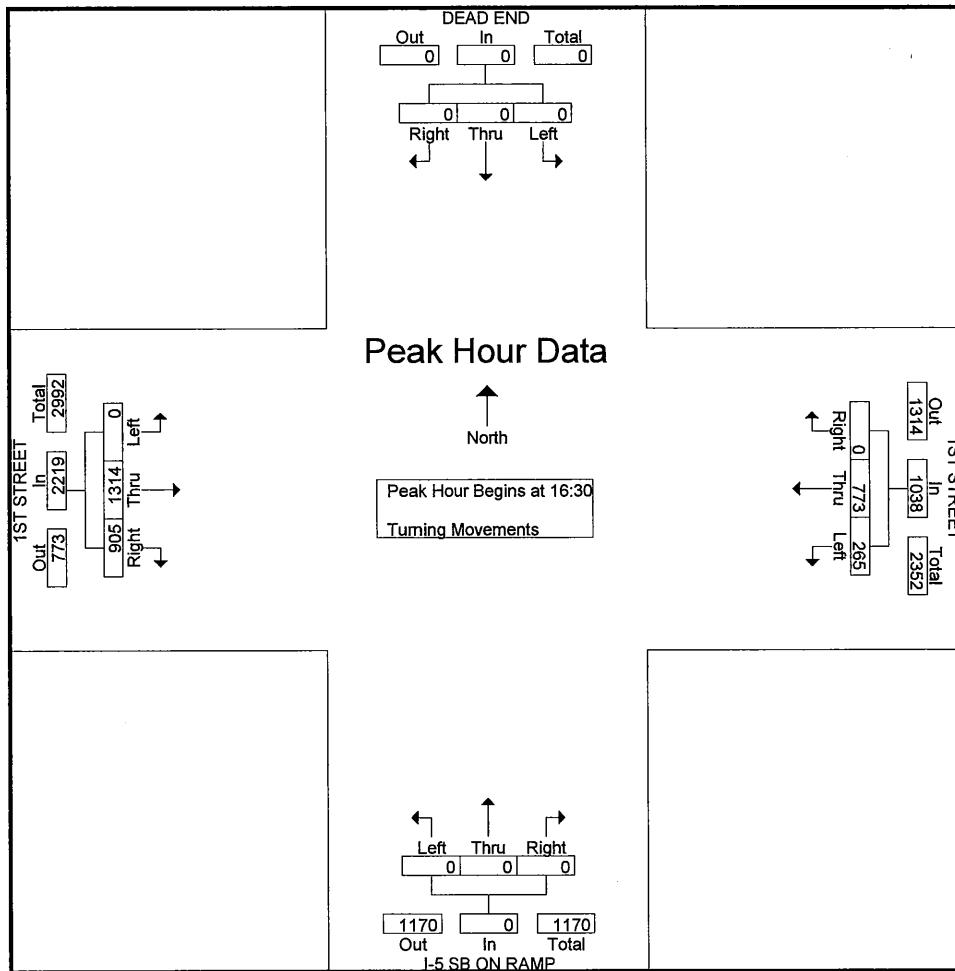

City: SANTA ANA
 N-S Direction: CABRILLO PARK DRIVE
 E-W Direction: 1ST STREET

File Name : H1610021
 Site Code : 00000000
 Start Date : 10/5/2016
 Page No : 1

Groups Printed- Turning Movements

Start Time	CABRILLO PARK DRIVE Southbound				1ST STREET Westbound				DRIVEWAY Northbound			1ST STREET Eastbound			Int. Total
	Right	Thru	Left	U-Turn	Right	Thru	Left	U-Turn	Right	Thru	Left	Right	Thru	Left	
07:00	57	3	9	3	21	135	0	0	0	0	1	0	116	51	396
07:15	64	6	13	2	20	151	1	0	0	0	1	2	111	61	432
07:30	95	0	14	1	26	210	2	0	0	0	1	3	111	52	515
07:45	85	12	18	1	38	199	5	3	2	0	0	4	120	52	539
Total	301	21	54	7	105	695	8	3	2	0	3	9	458	216	1882
08:00	83	9	15	0	25	174	6	1	2	0	2	7	164	55	543
08:15	57	8	11	0	35	174	1	1	0	0	0	5	162	60	514
08:30	48	13	9	0	33	143	5	1	1	1	0	2	159	50	465
08:45	42	5	20	1	31	146	0	2	0	1	1	1	163	68	481
Total	230	35	55	1	124	637	12	5	3	2	3	15	648	233	2003
16:00	67	0	18	1	32	170	2	1	5	3	3	1	228	92	623
16:15	62	0	20	1	20	168	3	2	4	0	1	0	238	97	616
16:30	65	0	17	0	29	182	0	2	3	15	2	2	233	116	666
16:45	62	2	20	0	29	156	1	0	1	9	5	2	233	108	628
Total	256	2	75	2	110	676	6	5	13	27	11	5	932	413	2533
17:00	109	0	26	0	38	216	0	3	4	6	3	2	221	97	725
17:15	80	1	17	3	47	169	0	2	2	4	3	0	232	106	666
17:30	88	0	19	0	52	158	0	1	2	7	1	0	248	113	689
17:45	53	1	22	0	50	164	0	2	1	0	3	0	259	106	661
Total	330	2	84	3	187	707	0	8	9	17	10	2	960	422	2741
Grand Total	1117	60	268	13	526	2715	26	21	27	46	27	31	2998	1284	9159
Apprch %	76.6	4.1	18.4	0.9	16	82.6	0.8	0.6	27	46	27	0.7	69.5	29.8	
Total %	12.2	0.7	2.9	0.1	5.7	29.6	0.3	0.2	0.3	0.5	0.3	0.3	32.7	14	

Start Time	CABRILLO PARK DRIVE Southbound					1ST STREET Westbound					DRIVEWAY Northbound				1ST STREET Eastbound				Int. Total
	Right	Thru	Left	U-Turn	App. Total	Right	Thru	Left	U-Turn	App. Total	Right	Thru	Left	App. Total	Right	Thru	Left	App. Total	
Peak Hour Analysis From 07:00 to 08:45 - Peak 1 of 1																			
Peak Hour for Entire Intersection Begins at 07:30																			
07:30	85	12	18	1	116	38	210		3	245	2	0	0	2	4	120	52	176	539
07:45	85	12	18	1	116	38	210		3	245	2	0	0	2	4	120	52	176	539
08:00	83	9	15	0	107	25	174	6					2	4	7	164	55	226	543
08:15	57	8	11	0	76	35	174	1	1	211	0	0	0	0	5	162	60	227	514
Total Volume	320	29	58	2	409	124	757	14	5	900	4	0	3	7	19	557	219	795	2111
% App. Total	78.2	7.1	14.2	0.5		13.8	84.1	1.6	0.6		57.1	0	42.9		2.4	70.1	27.5		
PHF	.842	.604	.806	.500	.881	.816	.901	.583	.417	.918	.500	.000	.375	.438	.679	.849	.913	.876	.972

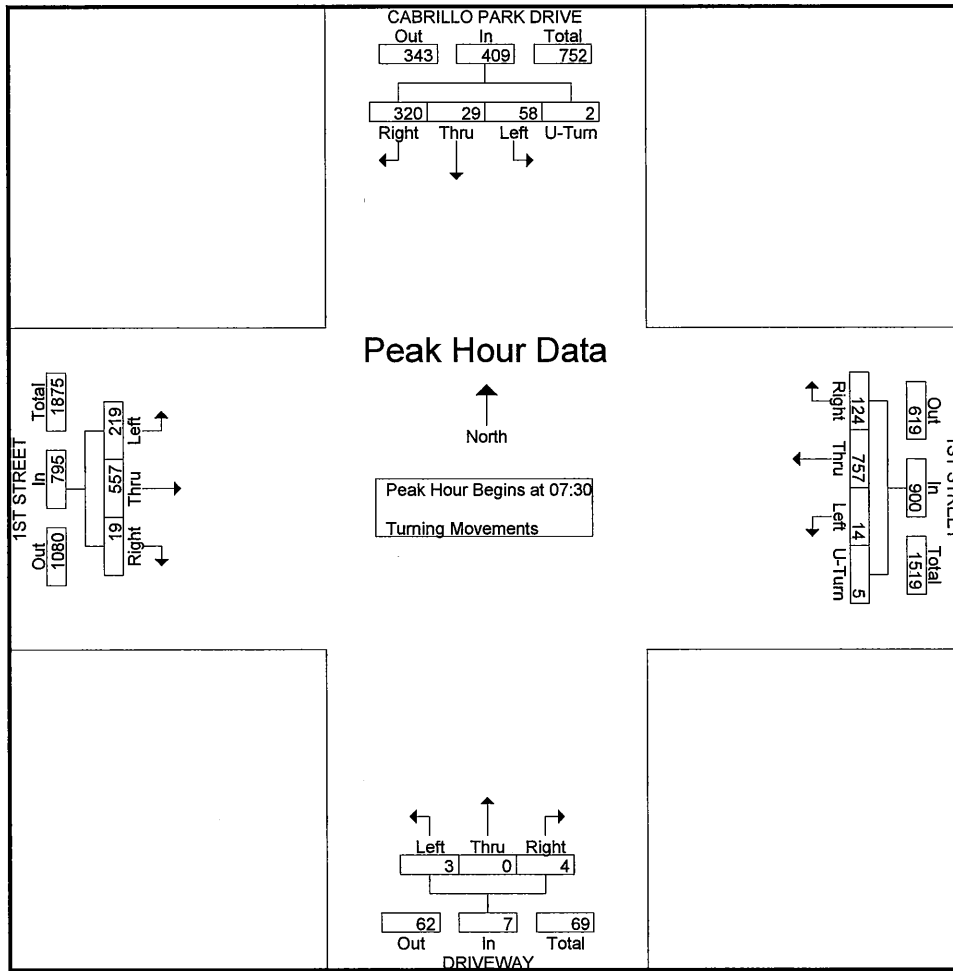

Start Time	CABRILLO PARK DRIVE Southbound					1ST STREET Westbound					DRIVEWAY Northbound				1ST STREET Eastbound				Int. Total
	Right	Thru	Left	U-Turn	App. Total	Right	Thru	Left	U-Turn	App. Total	Right	Thru	Left	App. Total	Right	Thru	Left	App. Total	
17:00	109	0	26	0	135	38	216	0	3	257	4	6	3	13	2	221	97	320	725
17:15	80	1	17	3	101	47	169	0	2	218	2	4	3	9	0	232	106	338	666
17:30	88	0	19	0	107	52						7	1	10	0	248	113	361	689
17:45	53	1	22	0	76	50	164	0	2	216	1	0	3	4	0	259	106	365	
Total Volume	330	2	84	3	419	187	707	0	8	902	9	17	10	36	2	960	422	1384	2741
% App. Total	78.8	0.5	20	0.7		20.7	78.4	0	0.9		25	47.2	27.8		0.1	69.4	30.5		
PHF	.757	.500	.808	.250	.776	.899	.818	.000	.667	.877	.563	.607	.833	.692	.250	.927	.934	.948	.945

Peak Hour Analysis From 16:00 to 17:45 - Peak 1 of 1
 Peak Hour for Entire Intersection Begins at 17:00

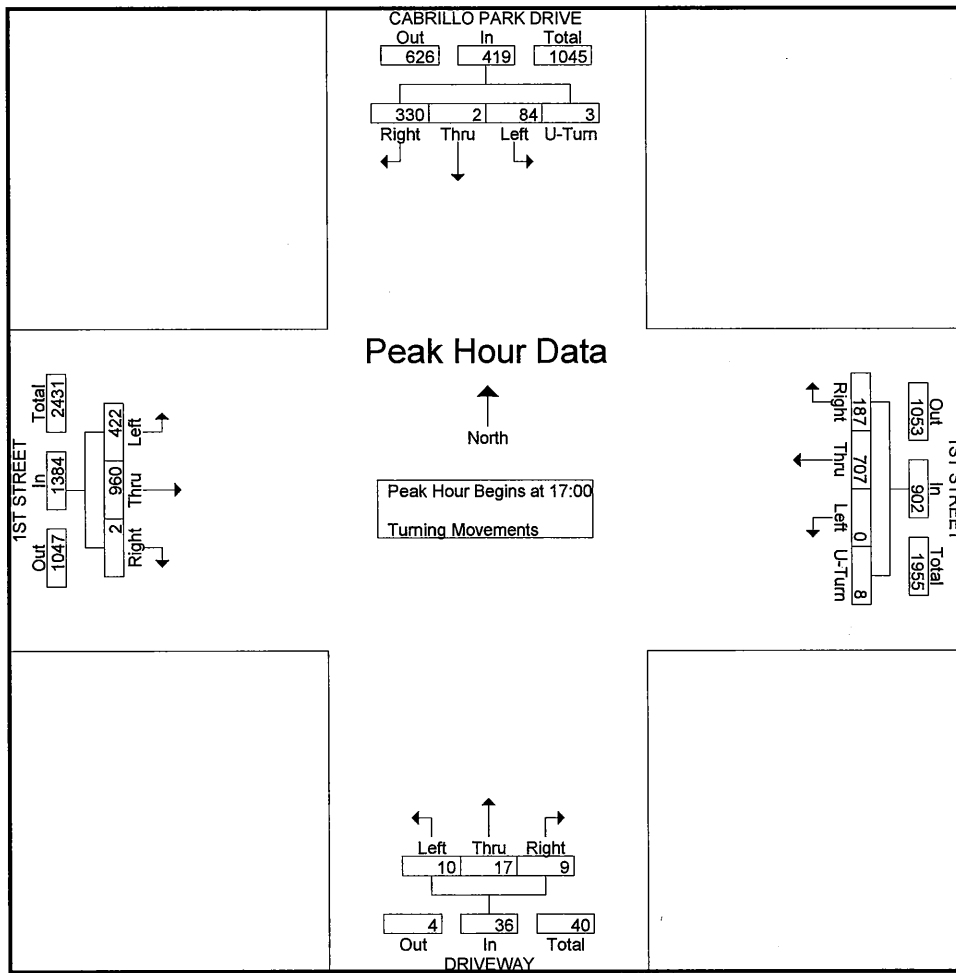

City: SANTA ANA
 N-S Direction: GOLDEN CIRCLE DRIVE
 E-W Direction: 1ST STREET

File Name : H1610022
 Site Code : 00000000
 Start Date : 10/5/2016
 Page No : 1

Groups Printed- Turning Movements

Start Time	GOLDEN CIRCLE DRIVE Southbound			1ST STREET Westbound				DRIVEWAY Northbound			1ST STREET Eastbound				Int. Total
	Right	Thru	Left	Right	Thru	Left	U-Turn	Right	Thru	Left	Right	Thru	Left	U-Turn	
07:00	5	1	3	3	149	6	0	0	0	1	3	119	9	0	299
07:15	4	13	3	14	161	12	0	3	6	6	5	104	7	0	338
07:30	4	7	7	14	231	18	0	4	5	8	6	100	11	1	416
07:45	9	10	5	17	217	34	1	14	11	14	7	121	9	0	469
Total	22	31	18	48	758	70	1	21	22	29	21	444	36	1	1522
08:00	5	3	5	23	187	8	0	9	8	8	2	150	13	2	423
08:15	13	0	5	13	190	3	0	0	0	0	2	140	23	0	389
08:30	3	3	6	15	169	4	0	1	0	0	2	143	13	1	360
08:45	9	1	8	11	179	9	0	1	1	0	6	163	24	0	412
Total	30	7	24	62	725	24	0	11	9	8	12	596	73	3	1584
16:00	22	1	10	12	165	3	1	6	2	12	4	226	21	1	486
16:15	14	0	7	13	173	5	2	11	5	4	0	233	20	1	488
16:30	17	0	9	18	179	4	0	5	3	16	2	226	24	1	504
16:45	24	3	11	27	153	6	0	8	4	2	1	220	23	2	484
Total	77	4	37	70	670	18	3	30	14	34	7	905	88	5	1962
17:00	22	1	12	40	215	4	0	11	1	7	3	231	12	5	564
17:15	21	1	13	11	200	10	0	8	5	1	1	230	12	0	513
17:30	17	1	5	19	183	3	2	5	1	5	1	245	11	4	502
17:45	15	0	2	20	208	6	1	4	4	5	1	247	19	0	532
Total	75	3	32	90	806	23	3	28	11	18	6	953	54	9	2111
Grand Total	204	45	111	270	2959	135	7	90	56	89	46	2898	251	18	7179
Apprch %	56.7	12.5	30.8	8	87.8	4	0.2	38.3	23.8	37.9	1.4	90.2	7.8	0.6	
Total %	2.8	0.6	1.5	3.8	41.2	1.9	0.1	1.3	0.8	1.2	0.6	40.4	3.5	0.3	

Start Time	GOLDEN CIRCLE DRIVE Southbound				1ST STREET Westbound					DRIVEWAY Northbound				1ST STREET Eastbound					Int. Total
	Right	Thru	Left	App. Total	Right	Thru	Left	U-Turn	App. Total	Right	Thru	Left	App. Total	Right	Thru	Left	U-Turn	App. Total	
07:30	4	7	7			231	18	0	263	4	5	8	17	6	100	11	1	118	416
07:45	9	10	5	24	17	217	34	1	269	14	11	14	39	7	121	9	0	137	469
08:00	5	3	5	13	23	187	8	0	218	9	8	8	25	2	150	13	2	167	423
08:15	13	0	5	18	13	190	3	0	206	0	0	0	0	2	140	23	0	165	389
Total Volume	31	20	22	73	67	825	63	1	956	27	24	30	81	17	511	56	3	587	1697
% App. Total	42.5	27.4	30.1		7	86.3	6.6	0.1		33.3	29.6	37		2.9	87.1	9.5	0.5		
PHF	.596	.500	.786	.760	.728	.893	.463	.250	.888	.482	.545	.536	.519	.607	.852	.609	.375	.879	.905

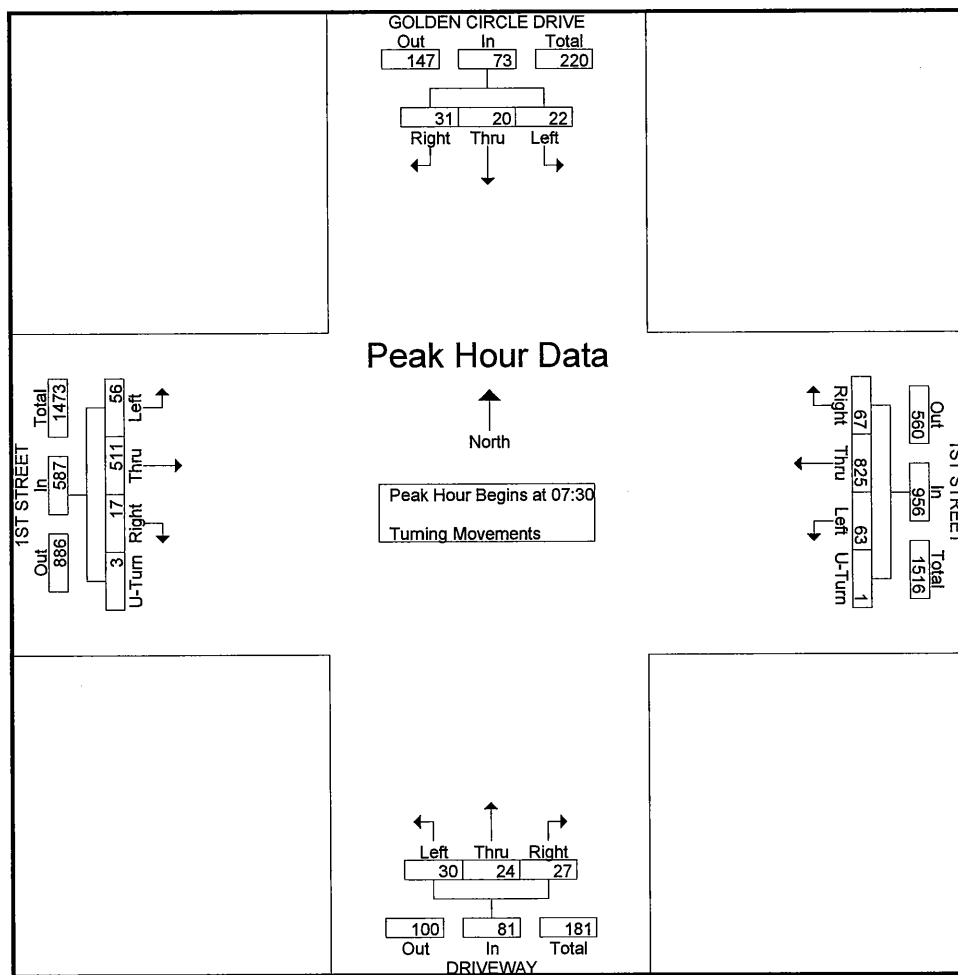

Start Time	GOLDEN CIRCLE DRIVE Southbound				1ST STREET Westbound					DRIVEWAY Northbound				1ST STREET Eastbound					Int. Total
	Right	Thru	Left	App. Total	Right	Thru	Left	U-Turn	App. Total	Right	Thru	Left	App. Total	Right	Thru	Left	U-Turn	App. Total	
17:00	22	1	12	35	40	215	4	0	259	11	1	7	19	3	231	12	5	251	564
17:15	21	1	13	35	11	200	10	0	221	8	5	1	14	1	230	12	0	243	513
17:30	17	1	5	23	19	183	3	2											
17:45	15	0	2	17	20	208	6	1	235	4	4	5	13	1	247	19	0	267	532
Total Volume	75	3	32	110	90	806	23	3	922	28	11	18	57	6	953	54	9	1022	2111
% App. Total	68.2	2.7	29.1		9.8	87.4	2.5	0.3		49.1	19.3	31.6		0.6	93.2	5.3	0.9		
PHF	.852	.750	.615	.786	.563	.937	.575	.375	.890	.636	.550	.643	.750	.500	.965	.711	.450	.957	.936

Peak Hour Analysis From 16:00 to 17:45 - Peak 1 of 1
 Peak Hour for Entire Intersection Begins at 17:00

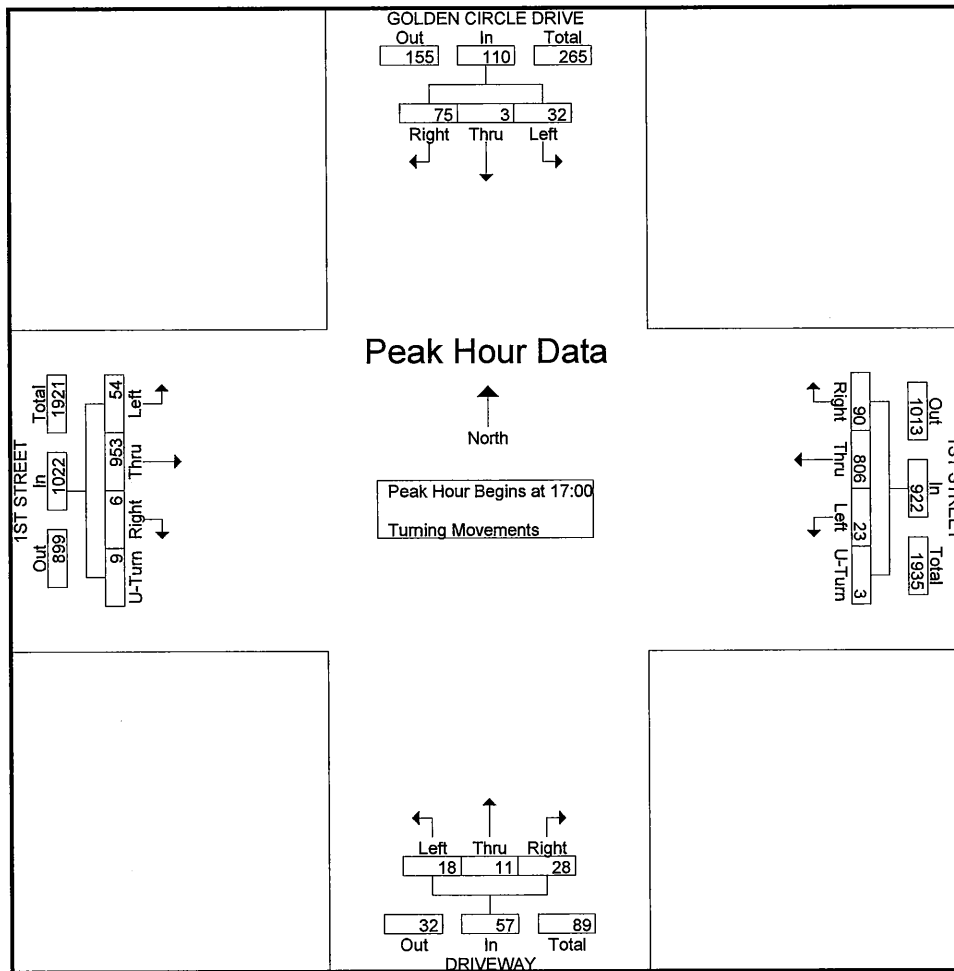

City: SANTA ANA
 N-S Direction: TUSTIN AVENUE
 E-W Direction: 1ST STREET

File Name : H1610023
 Site Code : 00000000
 Start Date : 10/6/2016
 Page No : 1

Groups Printed- Turning Movements

Start Time	TUSTIN AVENUE Southbound			1ST STREET Westbound			DEAD END Northbound			1ST STREET Eastbound			Int. Total
	Right	Thru	Left	Right	Thru	Left	Right	Thru	Left	Right	Thru	Left	
07:00	95	0	78	48	63	0	0	0	0	0	72	48	404
07:15	124	0	119	44	135	0	0	0	0	0	81	41	544
07:30	166	0	157	74	173	0	0	0	0	0	84	26	680
07:45	159	0	127	101	272	0	0	0	0	0	102	39	800
Total	544	0	481	267	643	0	0	0	0	0	339	154	2428
08:00	106	0	141	94	164	0	0	0	0	0	116	57	678
08:15	100	0	134	72	148	0	0	0	0	0	106	42	602
08:30	102	0	148	55	95	0	0	0	0	0	116	65	581
08:45	91	0	143	42	73	0	0	0	0	0	124	60	533
Total	399	0	566	263	480	0	0	0	0	0	462	224	2394
*** BREAK ***													
16:00	67	0	49	96	116	0	0	0	0	0	85	115	528
16:15	60	0	45	84	113	0	0	0	0	0	104	122	528
16:30	75	0	70	124	132	0	0	0	0	0	117	152	670
16:45	49	0	80	104	112	0	0	0	0	0	112	123	580
Total	251	0	244	408	473	0	0	0	0	0	418	512	2306
17:00	71	0	69	126	171	0	0	0	0	0	132	150	719
17:15	51	0	91	113	149	0	0	0	0	0	117	156	677
17:30	62	0	70	140	158	0	0	0	0	0	103	154	687
17:45	53	0	55	100	143	0	0	0	0	0	109	154	614
Total	237	0	285	479	621	0	0	0	0	0	461	614	2697
Grand Total	1431	0	1576	1417	2217	0	0	0	0	0	1680	1504	9825
Apprch %	47.6	0	52.4	39	61	0	0	0	0	0	52.8	47.2	
Total %	14.6	0	16	14.4	22.6	0	0	0	0	0	17.1	15.3	

City: SANTA ANA
 N-S Direction: TUSTIN AVENUE
 E-W Direction: 1ST STREET

File Name : H1610023
 Site Code : 00000000
 Start Date : 10/6/2016
 Page No : 2

Start Time	TUSTIN AVENUE Southbound				1ST STREET Westbound				DEAD END Northbound				1ST STREET Eastbound				Int. Total
	Right	Thru	Left	App. Total	Right	Thru	Left	App. Total	Right	Thru	Left	App. Total	Right	Thru	Left	App. Total	
Peak Hour Analysis From 07:00 to 08:45 - Peak 1 of 1																	
Peak Hour for Entire Intersection Begins at 07:30																	
07:30	166	0	157	323	74	173	0	247	0	0	0	0	0	84	26	110	680
07:45	159	0	127	286	101	272	0	373	0	0	0	0	0	102	39	141	800
08:00	106	0	141	247	94	164	0	258	0	0	0	0	0	116	57	173	678
08:15	100	0	134	234	72	148	0	220	0	0	0	0	0	106	42	148	602
Total Volume	531	0	559	1090	341	757	0	1098	0	0	0	0	0	408	164	572	2760
% App. Total	48.7	0	51.3		31.1	68.9	0		0	0	0		0	71.3	28.7		
PHF	.800	.000	.890	.844	.844	.696	.000	.736	.000	.000	.000	.000	.000	.879	.719	.827	.863

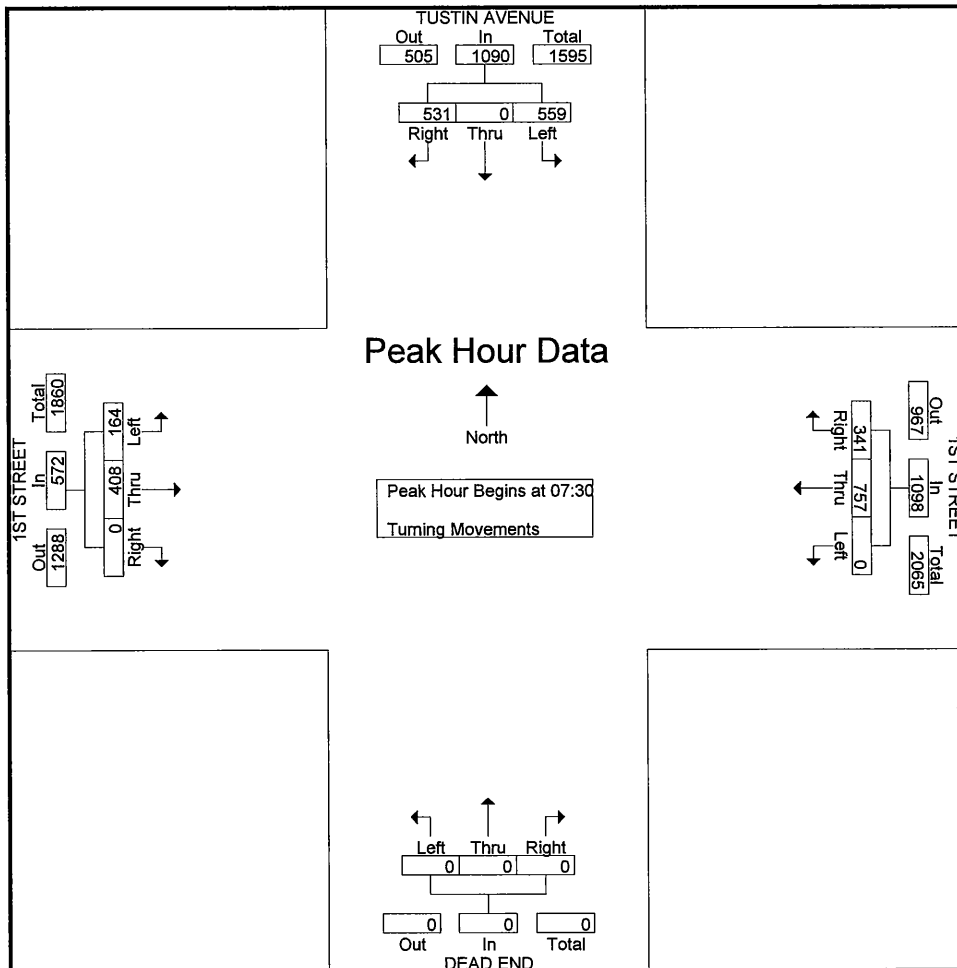

City: SANTA ANA
 N-S Direction: TUSTIN AVENUE
 E-W Direction: 1ST STREET

File Name : H1610023
 Site Code : 0000000
 Start Date : 10/6/2016
 Page No : 3

Start Time	TUSTIN AVENUE Southbound				1ST STREET Westbound				DEAD END Northbound				1ST STREET Eastbound				Int. Total
	Right	Thru	Left	App. Total	Right	Thru	Left	App. Total	Right	Thru	Left	App. Total	Right	Thru	Left	App. Total	
Peak Hour Analysis From 16:00 to 17:45 - Peak 1 of 1																	
Peak Hour for Entire Intersection Begins at 17:00																	
17:00	71	0	69	140	126	171	0	297	0	0	0	0	0	132	150	282	719
17:15	51	0	91	142	113	149	0	262	0	0	0	0	0	117	156	273	677
17:30	62	0	70	132	140	158	0	298	0	0	0	0	0	103	154	257	687
17:45	53	0	55	108	100	143	0	243	0	0	0	0	0	109	154	263	614
Total Volume	237	0	285	522	479	621	0	1100	0	0	0	0	0	461	614	1075	2697
% App. Total	45.4	0	54.6		43.5	56.5	0		0	0	0		0	42.9	57.1		
PHF	.835	.000	.783	.919	.855	.908	.000	.923	.000	.000	.000	.000	.000	.873	.984	.953	.938

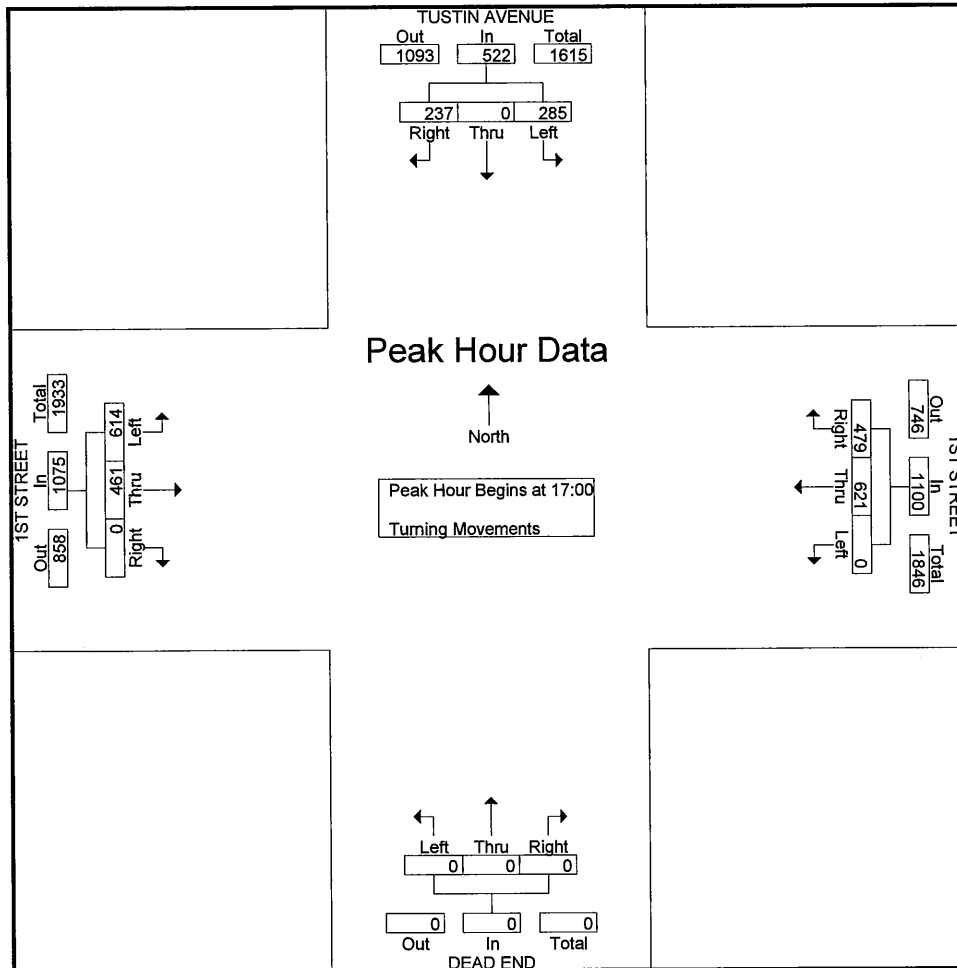

City: SANTA ANA
 N-S Direction: CABRILLO PARK DRIVE
 E-W Direction: XEROX CENTER DRIVEWAY

File Name : H1610024
 Site Code : 00000000
 Start Date : 10/6/2016
 Page No : 1

Groups Printed- Turning Movements

Start Time	CABRILLO PARK DRIVE Southbound			DEAD END Westbound			CABRILLO PARK DRIVE Northbound			XEROX CENTRE DRIVEWAY Eastbound			Int. Total
	Right	Thru	Left	Right	Thru	Left	Right	Thru	Left	Right	Thru	Left	
07:00	24	53	0	0	0	0	0	61	9	1	0	1	149
07:15	21	77	0	0	0	0	0	70	9	1	0	0	178
07:30	26	120	0	0	0	0	0	76	14	2	0	1	239
07:45	33	128	0	0	0	0	0	108	16	1	0	3	289
Total	104	378	0	0	0	0	0	315	48	5	0	5	855
08:00	38	95	0	0	0	0	0	100	22	2	0	2	259
08:15	46	120	0	0	0	0	0	68	21	2	0	1	258
08:30	39	111	0	0	0	0	0	75	23	3	0	3	254
08:45	50	88	0	0	0	0	0	64	25	3	0	5	235
Total	173	414	0	0	0	0	0	307	91	10	0	11	1006
*** BREAK ***													
16:00	4	72	0	0	0	0	0	118	8	20	0	35	257
16:15	2	51	0	0	0	0	0	144	3	19	0	33	252
16:30	4	77	0	0	0	0	0	157	2	31	0	34	305
16:45	4	62	0	0	0	0	0	138	6	26	0	25	261
Total	14	262	0	0	0	0	0	557	19	96	0	127	1075
17:00	5	76	0	0	0	0	0	149	1	45	0	43	319
17:15	3	58	0	0	0	0	0	158	3	27	0	33	282
17:30	2	79	0	0	0	0	0	147	0	15	0	32	275
17:45	2	70	0	0	0	0	0	157	3	17	0	17	266
Total	12	283	0	0	0	0	0	611	7	104	0	125	1142
Grand Total	303	1337	0	0	0	0	0	1790	165	215	0	268	4078
Apprch %	18.5	81.5	0	0	0	0	0	91.6	8.4	44.5	0	55.5	
Total %	7.4	32.8	0	0	0	0	0	43.9	4	5.3	0	6.6	

City: SANTA ANA
 N-S Direction: CABRILLO PARK DRIVE
 E-W Direction: XEROX CENTER DRIVEWAY

File Name : H1610024
 Site Code : 00000000
 Start Date : 10/6/2016
 Page No : 2

Start Time	CABRILLO PARK DRIVE Southbound				DEAD END Westbound				CABRILLO PARK DRIVE Northbound				XEROX CENTRE DRIVEWAY Eastbound				Int. Total
	Right	Thru	Left	App. Total	Right	Thru	Left	App. Total	Right	Thru	Left	App. Total	Right	Thru	Left	App. Total	
Peak Hour Analysis From 07:00 to 08:45 - Peak 1 of 1																	
Peak Hour for Entire Intersection Begins at 07:45																	
07:45	33	128	0	161	0	0	0	0	0	108	16	124	1	0	3	4	289
08:00	38	95	0	133	0	0	0	0	0	100	22	122	2	0	2	4	259
08:15	46	120	0	166	0	0	0	0	0	68	21	89	2	0	1	3	258
08:30	39	111	0	150	0	0	0	0	0	75	23	98	3	0	3	6	254
Total Volume	156	454	0	610	0	0	0	0	0	351	82	433	8	0	9	17	1060
% App. Total	25.6	74.4	0		0	0	0		0	81.1	18.9		47.1	0	52.9		
PHF	.848	.887	.000	.919	.000	.000	.000	.000	.000	.813	.891	.873	.667	.000	.750	.708	.917

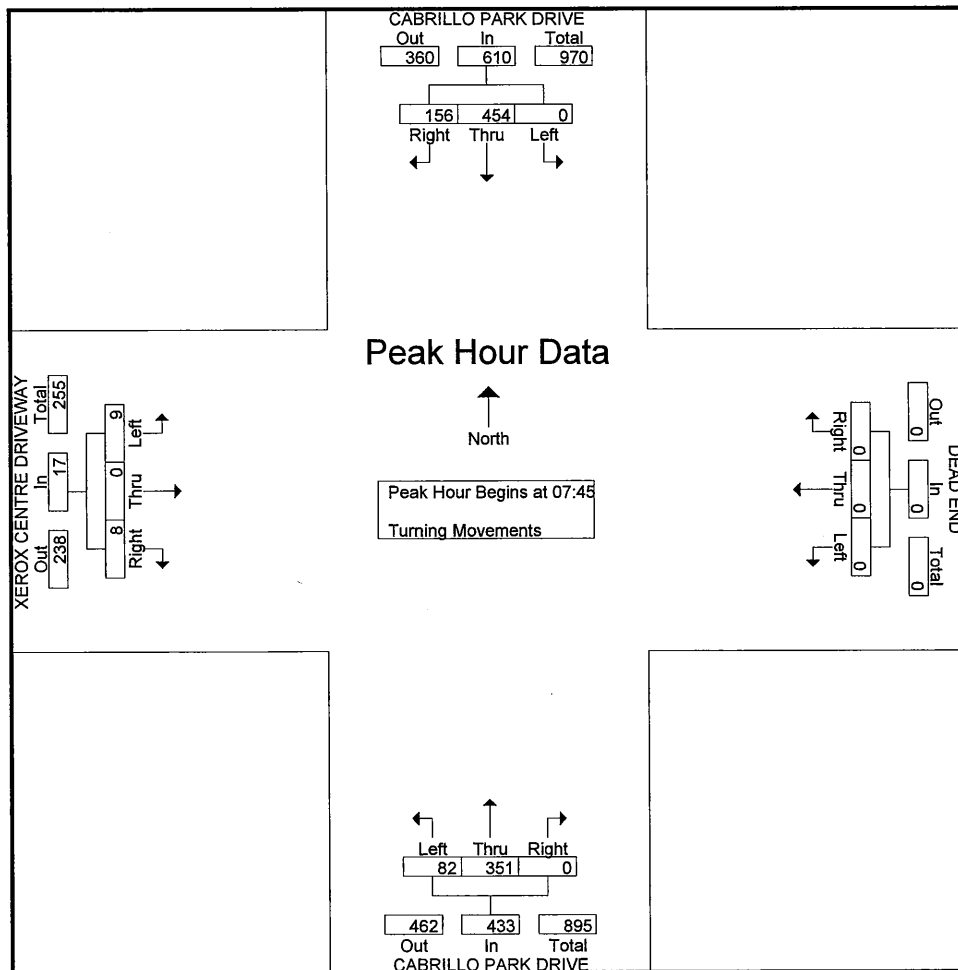

City: SANTA ANA
 N-S Direction: CABRILLO PARK DRIVE
 E-W Direction: XEROX CENTER DRIVEWAY

File Name : H1610024
 Site Code : 0000000
 Start Date : 10/6/2016
 Page No : 3

Start Time	CABRILLO PARK DRIVE Southbound				DEAD END Westbound				CABRILLO PARK DRIVE Northbound				XEROX CENTRE DRIVEWAY Eastbound				Int. Total
	Right	Thru	Left	App. Total	Right	Thru	Left	App. Total	Right	Thru	Left	App. Total	Right	Thru	Left	App. Total	
Peak Hour Analysis From 16:00 to 17:45 - Peak 1 of 1																	
Peak Hour for Entire Intersection Begins at 16:30																	
16:30	4	77	0	81	0	0	0	0	0	157	2	159	31	0	34	65	305
16:45	4	62	0	66	0	0	0	0	0	138	6	144	26	0	25	51	261
17:00	5	76	0	81	0	0	0	0	0	149	1	150	45	0	43	88	319
17:15	3	58	0	61	0	0	0	0	0	158	3	161	27	0	33	60	282
Total Volume	16	273	0	289	0	0	0	0	0	602	12	614	129	0	135	264	1167
% App. Total	5.5	94.5	0		0	0	0		0	98	2		48.9	0	51.1		
PHF	.800	.886	.000	.892	.000	.000	.000	.000	.000	.953	.500	.953	.717	.000	.785	.750	.915

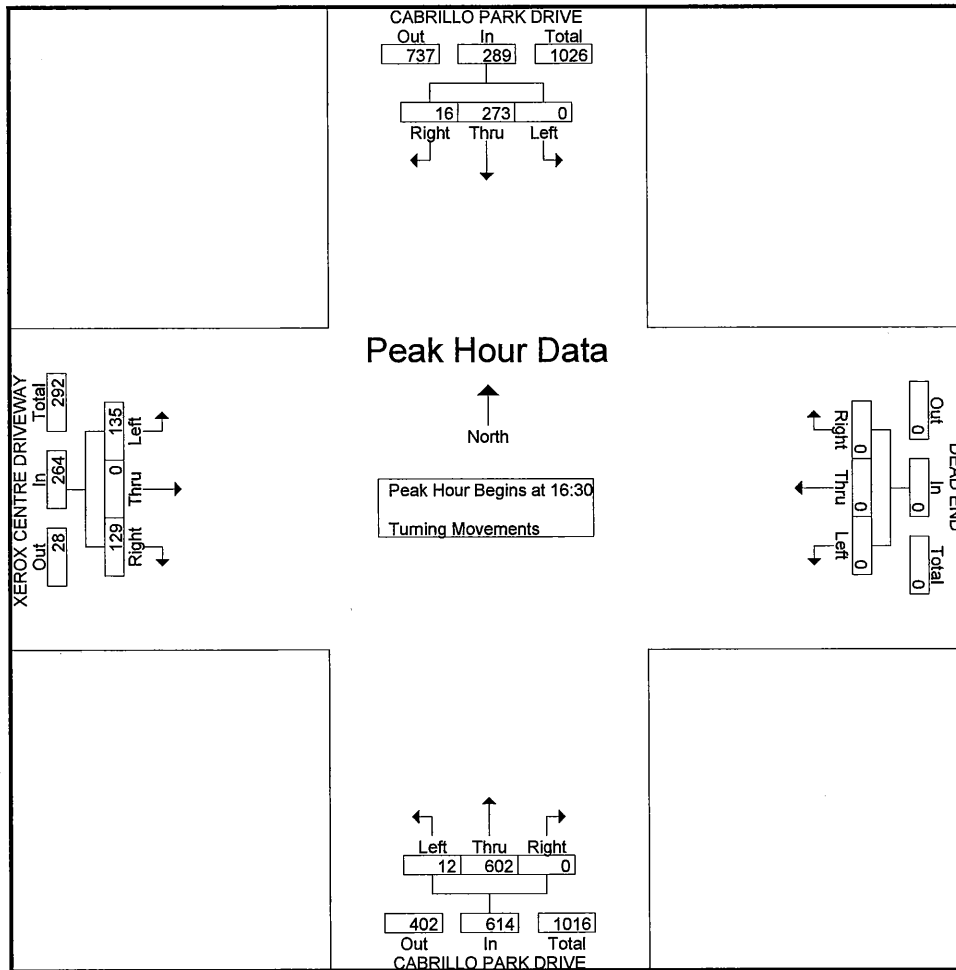

City: SANTA ANA
 N-S Direction: CABRILLO PARK DRIVE
 E-W Direction: STATE FUND DRIVEWAY

File Name : H1610025
 Site Code : 00000000
 Start Date : 10/6/2016
 Page No : 1

Groups Printed- Turning Movements

Start Time	CABRILLO PARK DRIVE Southbound			STATE FUND DRIVEWAY Westbound			CABRILLO PARK DRIVE Northbound			STATE FUND DRIVEWAY Eastbound			Int. Total
	Right	Thru	Left	Right	Thru	Left	Right	Thru	Left	Right	Thru	Left	
07:00	48	86	0	0	0	0	0	63	1	1	0	3	202
07:15	36	104	0	0	0	0	0	65	4	0	0	0	209
07:30	26	130	0	0	0	0	0	63	6	0	0	1	226
07:45	29	158	0	0	0	0	0	109	9	1	0	1	307
Total	139	478	0	0	0	0	0	300	20	2	0	5	944
08:00	31	134	0	0	0	0	1	92	6	3	0	0	267
08:15	28	149	0	0	0	0	0	64	2	3	0	1	247
08:30	14	143	0	0	0	0	0	74	6	2	0	4	243
08:45	17	124	0	0	0	0	1	74	0	0	0	1	217
Total	90	550	0	0	0	0	2	304	14	8	0	6	974
*** BREAK ***													
16:00	6	57	0	0	0	0	1	176	0	17	0	30	287
16:15	4	51	0	0	0	0	3	175	0	5	0	12	250
16:30	4	55	0	0	0	0	1	185	0	17	0	23	285
16:45	7	45	1	0	0	0	0	155	0	15	0	19	242
Total	21	208	1	0	0	0	5	691	0	54	0	84	1064
17:00	1	58	0	0	0	0	0	191	0	17	0	37	304
17:15	2	55	0	0	0	0	1	190	1	9	0	12	270
17:30	1	63	0	0	0	0	0	173	0	11	0	22	270
17:45	5	58	0	0	0	0	3	168	4	13	0	11	262
Total	9	234	0	0	0	0	4	722	5	50	0	82	1106
Grand Total	259	1470	1	0	0	0	11	2017	39	114	0	177	4088
Approch %	15	85	0.1	0	0	0	0.5	97.6	1.9	39.2	0	60.8	
Total %	6.3	36	0	0	0	0	0.3	49.3	1	2.8	0	4.3	

City: SANTA ANA
 N-S Direction: CABRILLO PARK DRIVE
 E-W Direction: STATE FUND DRIVEWAY

File Name : H1610025
 Site Code : 00000000
 Start Date : 10/6/2016
 Page No : 2

Start Time	CABRILLO PARK DRIVE Southbound				STATE FUND DRIVEWAY Westbound				CABRILLO PARK DRIVE Northbound				STATE FUND DRIVEWAY Eastbound				Int. Total
	Right	Thru	Left	App. Total	Right	Thru	Left	App. Total	Right	Thru	Left	App. Total	Right	Thru	Left	App. Total	
Peak Hour Analysis From 07:00 to 08:45 - Peak 1 of 1																	
Peak Hour for Entire Intersection Begins at 07:45																	
07:45	29	158	0	187	0	0	0	0	0	109	9	118	1	0	1	2	307
08:00	31	134	0	165	0	0	0	0	1	92	6	99	3	0	0	3	267
08:15	28	149	0	177	0	0	0	0	0	64	2	66	3	0	1	4	247
08:30	14	143	0	157	0	0	0	0	0	74	6	80	2	0	4	6	243
Total Volume	102	584	0	686	0	0	0	0	1	339	23	363	9	0	6	15	1064
% App. Total	14.9	85.1	0		0	0	0		0.3	93.4	6.3		60	0	40		
PHF	.823	.924	.000	.917	.000	.000	.000	.000	.250	.778	.639	.769	.750	.000	.375	.625	.866

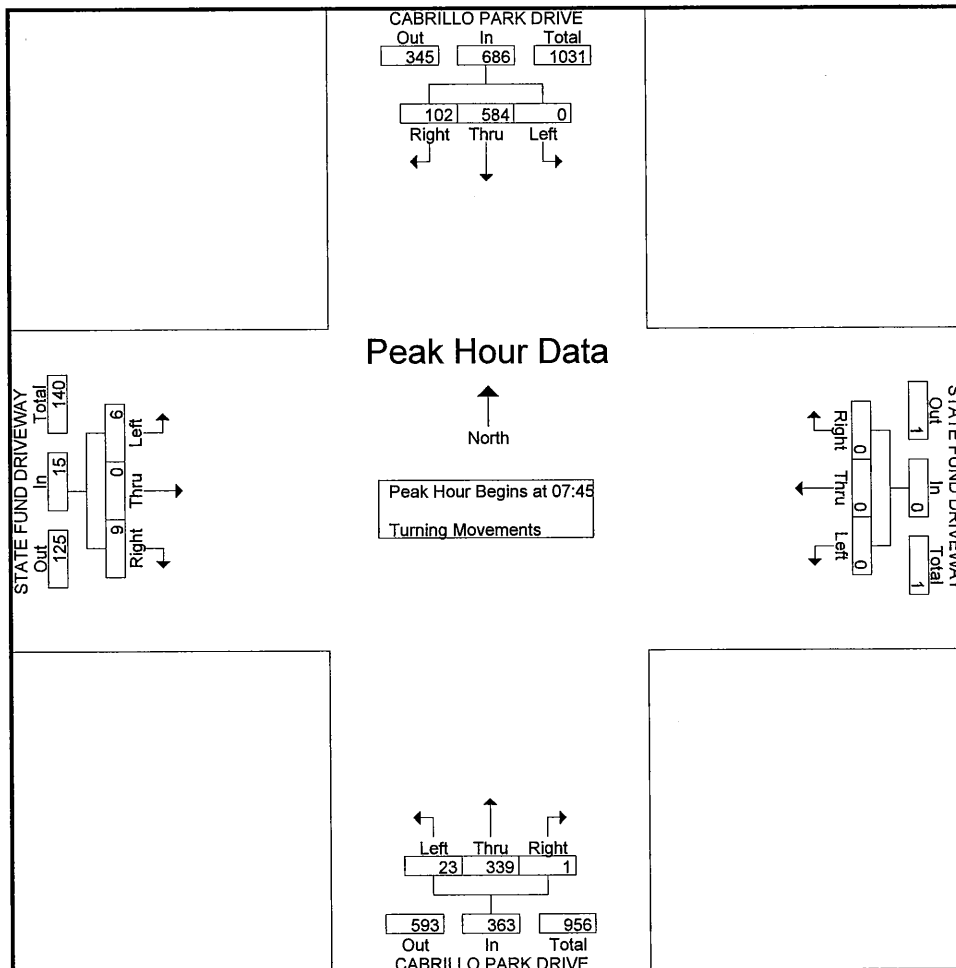

City: SANTA ANA
 N-S Direction: CABRILLO PARK DRIVE
 E-W Direction: STATE FUND DRIVEWAY

File Name : H1610025
 Site Code : 00000000
 Start Date : 10/6/2016
 Page No : 3

Start Time	CABRILLO PARK DRIVE Southbound				STATE FUND DRIVEWAY Westbound				CABRILLO PARK DRIVE Northbound				STATE FUND DRIVEWAY Eastbound				Int. Total
	Right	Thru	Left	App. Total	Right	Thru	Left	App. Total	Right	Thru	Left	App. Total	Right	Thru	Left	App. Total	
Peak Hour Analysis From 16:00 to 17:45 - Peak 1 of 1																	
Peak Hour for Entire Intersection Begins at 17:00																	
17:00	1	58	0	59	0	0	0	0	0	191	0	191	17	0	37	54	304
17:15	2	55	0	57	0	0	0	0	1	190	1	192	9	0	12	21	270
17:30	1	63	0	64	0	0	0	0	0	173	0	173	11	0	22	33	270
17:45	5	58	0	63	0	0	0	0	3	168	4	175	13	0	11	24	262
Total Volume	9	234	0	243	0	0	0	0	4	722	5	731	50	0	82	132	1106
% App. Total	3.7	96.3	0		0	0	0		0.5	98.8	0.7		37.9	0	62.1		
PHF	.450	.929	.000	.949	.000	.000	.000	.000	.333	.945	.313	.952	.735	.000	.554	.611	.910

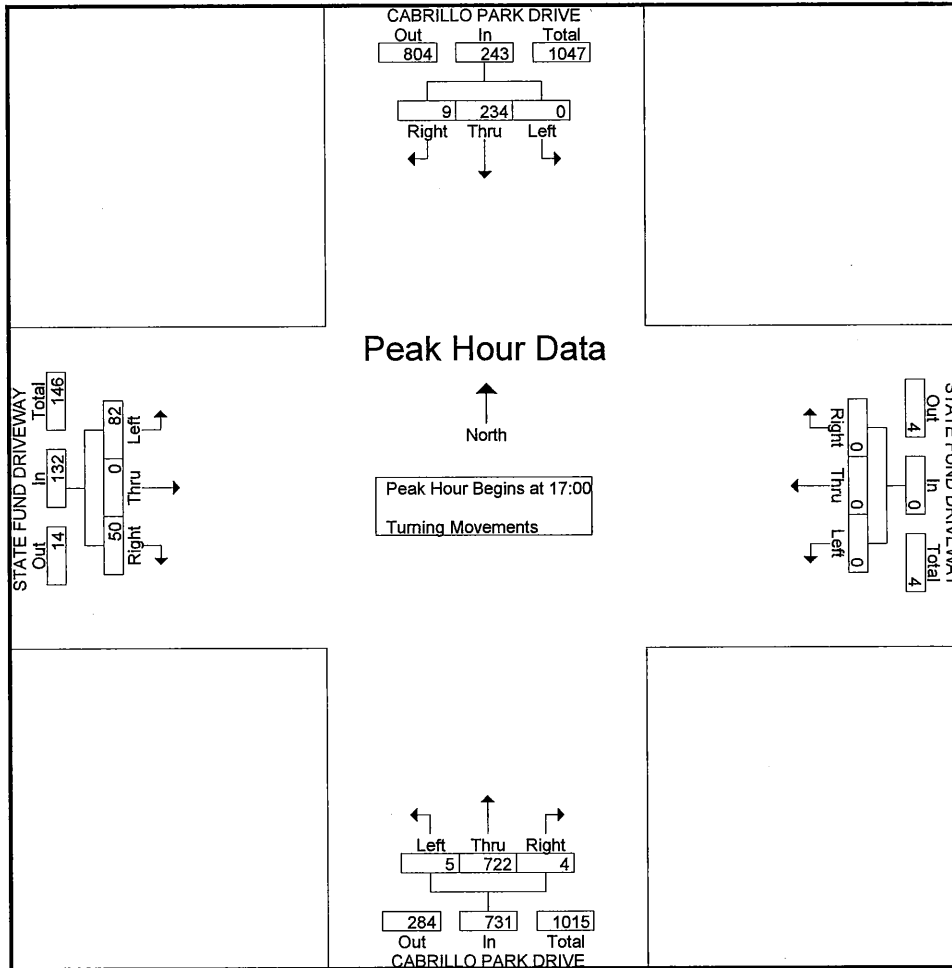

City: SANTA ANA
 N-S Direction: I-5 SB OFF RAMP-MABURY S
 E-W Direction: 4TH STREET

File Name : H1610026
 Site Code : 00000000
 Start Date : 10/4/2016
 Page No : 1

Groups Printed- Turning Movements

Start Time	OFF RAMP Southbound			4TH STREET Westbound			MABURY STREET Northbound			4TH STREET Eastbound			Int. Total
	Right	Thru	Left	Right	Thru	Left	Right	Thru	Left	Right	Thru	Left	
07:00	9	55	39	0	108	4	0	0	0	14	80	0	309
07:15	6	46	50	0	153	5	0	0	0	41	114	0	415
07:30	8	56	44	0	153	11	0	0	0	65	159	0	496
07:45	14	84	52	0	177	17	0	0	0	37	177	0	558
Total	37	241	185	0	591	37	0	0	0	157	530	0	1778
08:00	10	67	49	0	159	13	0	0	0	40	132	0	470
08:15	16	76	71	0	132	16	0	0	0	37	115	0	463
08:30	10	44	60	0	136	18	0	0	0	33	115	0	416
08:45	10	48	59	0	144	10	0	0	0	14	104	0	389
Total	46	235	239	0	571	57	0	0	0	124	466	0	1738
*** BREAK ***													
16:00	12	58	66	0	243	19	0	0	0	40	100	0	538
16:15	14	45	58	0	226	26	0	0	0	43	123	0	535
16:30	10	65	62	0	250	10	0	0	0	29	116	0	542
16:45	15	51	61	0	247	13	0	0	0	31	123	0	541
Total	51	219	247	0	966	68	0	0	0	143	462	0	2156
17:00	13	52	74	0	274	21	0	0	0	43	157	0	634
17:15	12	58	76	0	213	17	0	0	0	45	143	0	564
17:30	8	44	60	0	220	12	0	0	0	35	119	0	498
17:45	16	48	64	0	202	12	0	0	0	31	84	0	457
Total	49	202	274	0	909	62	0	0	0	154	503	0	2153
Grand Total	183	897	945	0	3037	224	0	0	0	578	1961	0	7825
Apprch %	9	44.3	46.7	0	93.1	6.9	0	0	0	22.8	77.2	0	
Total %	2.3	11.5	12.1	0	38.8	2.9	0	0	0	7.4	25.1	0	

City: SANTA ANA
 N-S Direction: I-5 SB OFF RAMP-MABURY S
 E-W Direction: 4TH STREET

File Name : H1610026
 Site Code : 00000000
 Start Date : 10/4/2016
 Page No : 2

Start Time	OFF RAMP Southbound				4TH STREET Westbound				MABURY STREET Northbound				4TH STREET Eastbound				Int. Total
	Right	Thru	Left	App. Total	Right	Thru	Left	App. Total	Right	Thru	Left	App. Total	Right	Thru	Left	App. Total	
Peak Hour Analysis From 07:00 to 08:45 - Peak 1 of 1																	
Peak Hour for Entire Intersection Begins at 07:30																	
07:30	8	56	44	108	0	153	11	164	0	0	0	0	65	159	0	224	496
07:45	14	84	52	150	0	177	17	194	0	0	0	0	37	177	0	214	558
08:00	10	67	49	126	0	159	13	172	0	0	0	0	40	132	0	172	470
08:15	16	76	71	163	0	132	16	148	0	0	0	0	37	115	0	152	463
Total Volume	48	283	216	547	0	621	57	678	0	0	0	0	179	583	0	762	1987
% App. Total	8.8	51.7	39.5		0	91.6	8.4		0	0	0		23.5	76.5	0		
PHF	.750	.842	.761	.839	.000	.877	.838	.874	.000	.000	.000	.000	.688	.823	.000	.850	.890

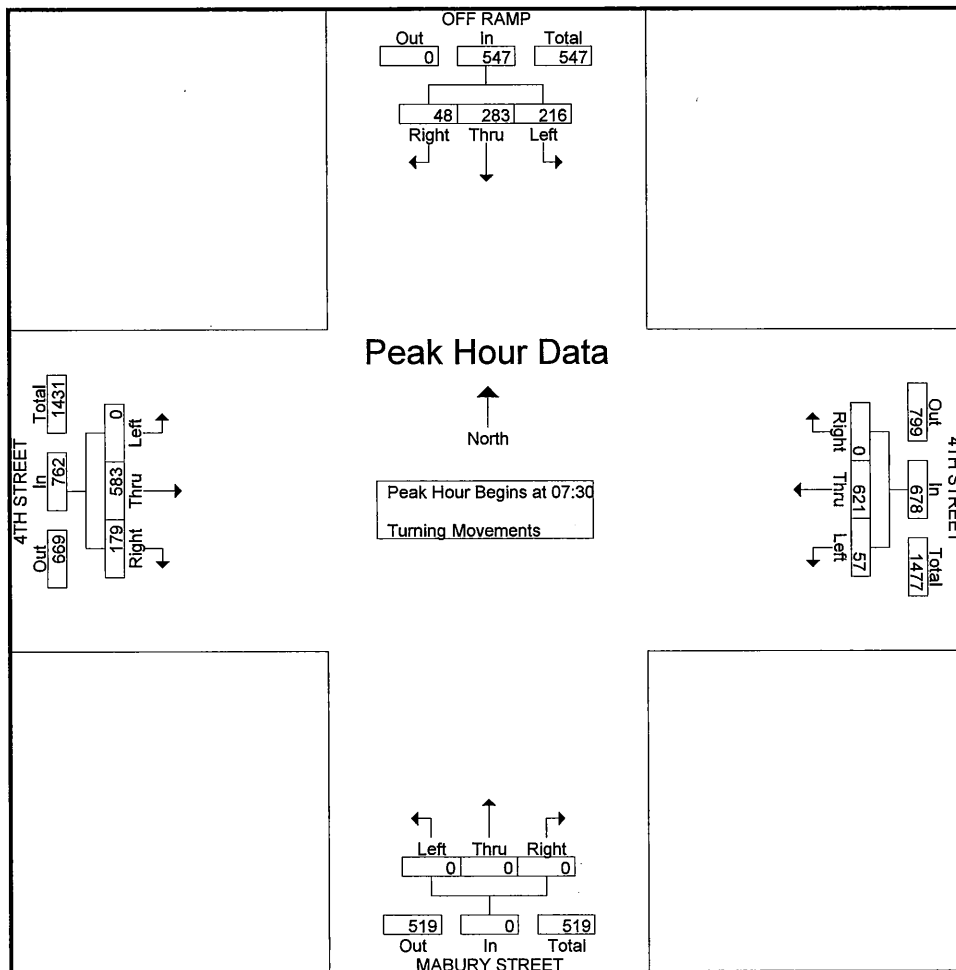

City: SANTA ANA
 N-S Direction: I-5 SB OFF RAMP-MABURY S
 E-W Direction: 4TH STREET

File Name : H1610026
 Site Code : 00000000
 Start Date : 10/4/2016
 Page No : 3

Start Time	OFF RAMP Southbound				4TH STREET Westbound				MABURY STREET Northbound				4TH STREET Eastbound				Int. Total
	Right	Thru	Left	App. Total	Right	Thru	Left	App. Total	Right	Thru	Left	App. Total	Right	Thru	Left	App. Total	
Peak Hour Analysis From 16:00 to 17:45 - Peak 1 of 1																	
Peak Hour for Entire Intersection Begins at 16:30																	
16:30	10	65	62	137	0	250	10	260	0	0	0	0	29	116	0	145	542
16:45	15	51	61	127	0	247	13	260	0	0	0	0	31	123	0	154	541
17:00	13	52	74	139	0	274	21	295	0	0	0	0	43	157	0	200	634
17:15	12	58	76	146	0	213	17	230	0	0	0	0	45	143	0	188	564
Total Volume	50	226	273	549	0	984	61	1045	0	0	0	0	148	539	0	687	2281
% App. Total	9.1	41.2	49.7		0	94.2	5.8		0	0	0		21.5	78.5	0		
PHF	.833	.869	.898	.940	.000	.898	.726	.886	.000	.000	.000	.000	.822	.858	.000	.859	.899

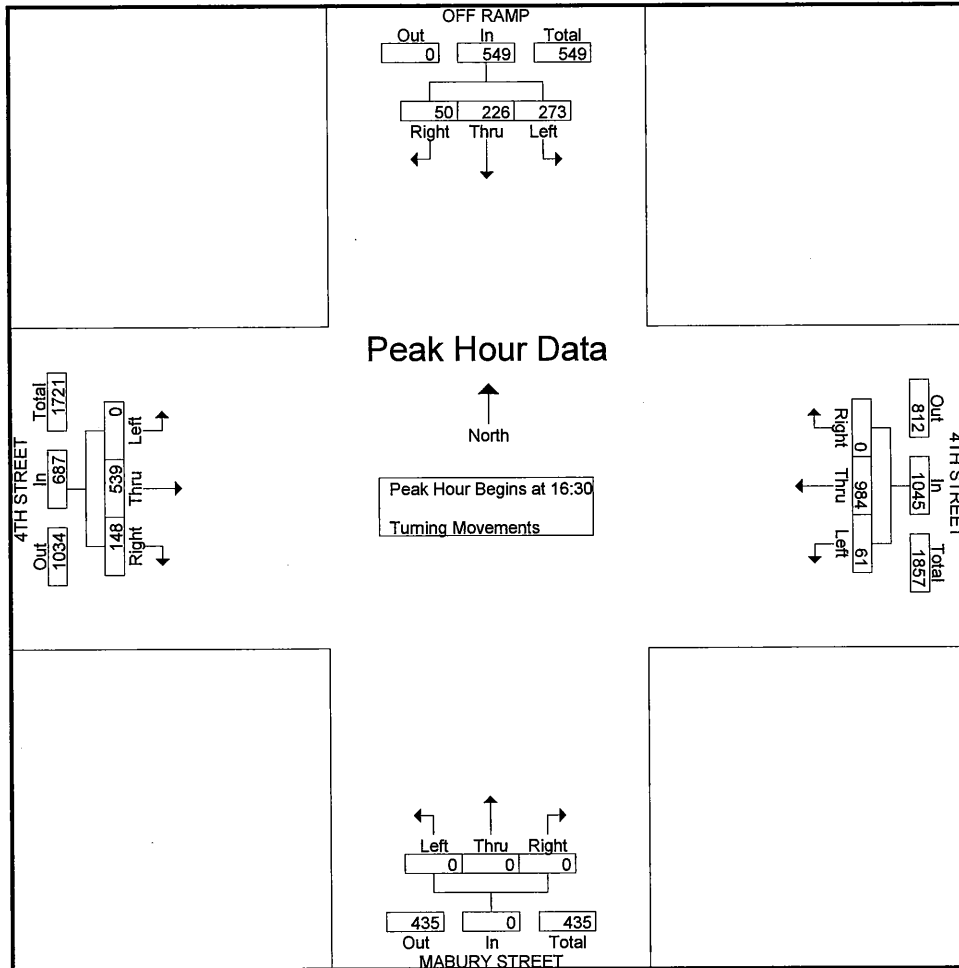

City: SANTA ANA
 N-S Direction: I-5 NB RAMPS
 E-W Direction: 4TH STREET

File Name : H1610027
 Site Code : 00000000
 Start Date : 10/4/2016
 Page No : 1

Groups Printed- Turning Movements

Start Time	ON RAMP Southbound			4TH STREET Westbound			OFF RAMP Northbound			4TH STREET Eastbound			Int. Total
	Right	Thru	Left	Right	Thru	Left	Right	Thru	Left	Right	Thru	Left	
07:00	0	0	0	90	103	0	51	0	35	0	108	17	404
07:15	0	0	0	108	123	0	71	0	37	0	164	8	511
07:30	0	0	0	114	135	0	54	0	31	0	177	12	523
07:45	0	0	0	128	130	0	59	0	35	0	234	5	591
Total	0	0	0	440	491	0	235	0	138	0	683	42	2029
08:00	0	0	0	129	119	0	82	0	48	0	181	4	563
08:15	0	0	0	112	104	0	85	0	44	0	187	7	539
08:30	0	0	0	107	114	0	83	0	47	0	167	14	532
08:45	0	0	0	112	99	0	87	0	40	0	152	9	499
Total	0	0	0	460	436	0	337	0	179	0	687	34	2133
*** BREAK ***													
16:00	0	0	0	241	232	0	41	0	40	0	150	15	719
16:15	0	0	0	208	203	0	41	0	41	0	161	12	666
16:30	0	0	0	210	208	0	42	0	46	0	175	10	691
16:45	0	0	0	198	218	0	37	0	41	0	177	10	681
Total	0	0	0	857	861	0	161	0	168	0	663	47	2757
17:00	0	0	0	252	218	0	50	0	44	0	212	13	789
17:15	0	0	0	254	193	0	33	0	41	0	197	12	730
17:30	0	0	0	192	197	0	32	0	36	0	170	14	641
17:45	0	0	0	204	194	0	48	0	28	0	132	16	622
Total	0	0	0	902	802	0	163	0	149	0	711	55	2782
Grand Total	0	0	0	2659	2590	0	896	0	634	0	2744	178	9701
Apprch %	0	0	0	50.7	49.3	0	58.6	0	41.4	0	93.9	6.1	
Total %	0	0	0	27.4	26.7	0	9.2	0	6.5	0	28.3	1.8	

City: SANTA ANA
 N-S Direction: I-5 NB RAMPS
 E-W Direction: 4TH STREET

File Name : H1610027
 Site Code : 00000000
 Start Date : 10/4/2016
 Page No : 2

Start Time	ON RAMP Southbound				4TH STREET Westbound				OFF RAMP Northbound				4TH STREET Eastbound				Int. Total
	Right	Thru	Left	App. Total	Right	Thru	Left	App. Total	Right	Thru	Left	App. Total	Right	Thru	Left	App. Total	
Peak Hour Analysis From 07:00 to 08:45 - Peak 1 of 1																	
Peak Hour for Entire Intersection Begins at 07:45																	
07:45	0	0	0	0	128	130	0	258	59	0	35	94	0	234	5	239	591
08:00	0	0	0	0	129	119	0	248	82	0	48	130	0	181	4	185	563
08:15	0	0	0	0	112	104	0	216	85	0	44	129	0	187	7	194	539
08:30	0	0	0	0	107	114	0	221	83	0	47	130	0	167	14	181	532
Total Volume	0	0	0	0	476	467	0	943	309	0	174	483	0	769	30	799	2225
% App. Total	0	0	0	0	50.5	49.5	0		64	0	36		0	96.2	3.8		
PHF	.000	.000	.000	.000	.922	.898	.000	.914	.909	.000	.906	.929	.000	.822	.536	.836	.941

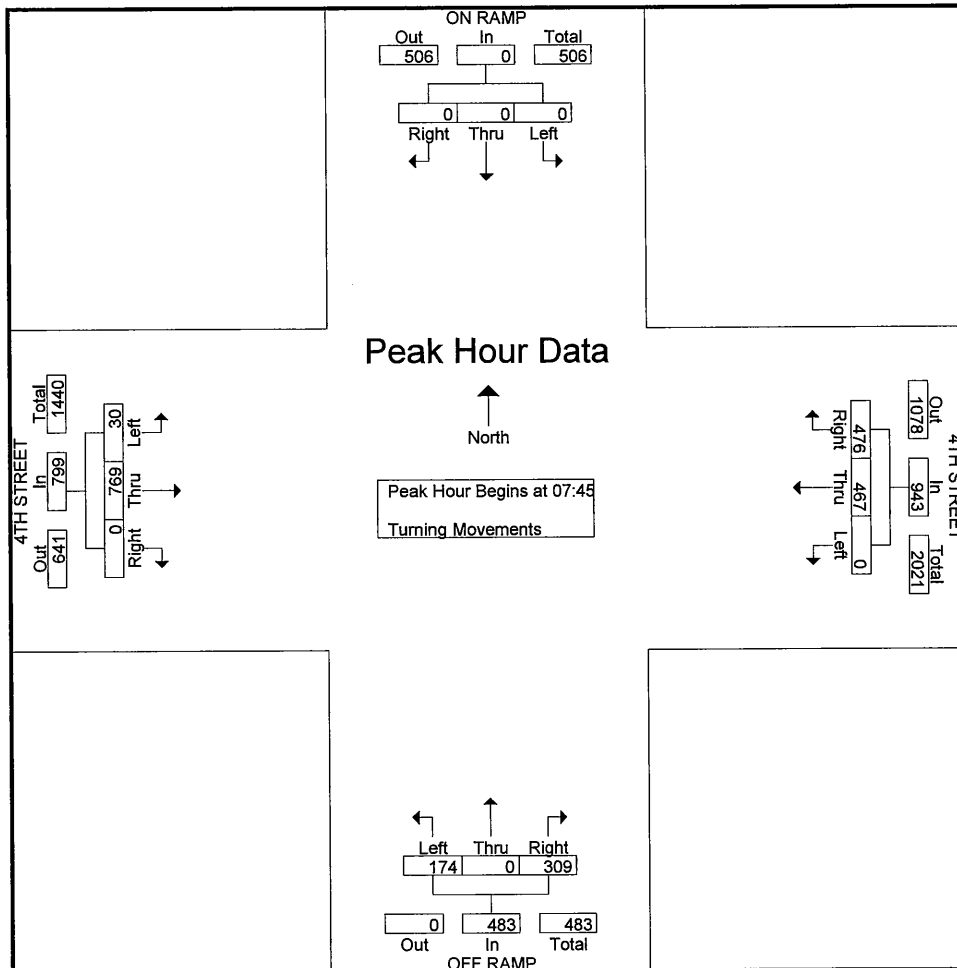

City: SANTA ANA
 N-S Direction: I-5 NB RAMPS
 E-W Direction: 4TH STREET

File Name : H1610027
 Site Code : 00000000
 Start Date : 10/4/2016
 Page No : 3

Start Time	ON RAMP Southbound				4TH STREET Westbound				OFF RAMP Northbound				4TH STREET Eastbound				Int. Total
	Right	Thru	Left	App. Total	Right	Thru	Left	App. Total	Right	Thru	Left	App. Total	Right	Thru	Left	App. Total	
Peak Hour Analysis From 16:00 to 17:45 - Peak 1 of 1																	
Peak Hour for Entire Intersection Begins at 16:30																	
16:30	0	0	0	0	210	208	0	418	42	0	46	88	0	175	10	185	691
16:45	0	0	0	0	198	218	0	416	37	0	41	78	0	177	10	187	681
17:00	0	0	0	0	252	218	0	470	50	0	44	94	0	212	13	225	789
17:15	0	0	0	0	254	193	0	447	33	0	41	74	0	197	12	209	730
Total Volume	0	0	0	0	914	837	0	1751	162	0	172	334	0	761	45	806	2891
% App. Total	0	0	0	0	52.2	47.8	0		48.5	0	51.5		0	94.4	5.6		
PHF	.000	.000	.000	.000	.900	.960	.000	.931	.810	.000	.935	.888	.000	.897	.865	.896	.916

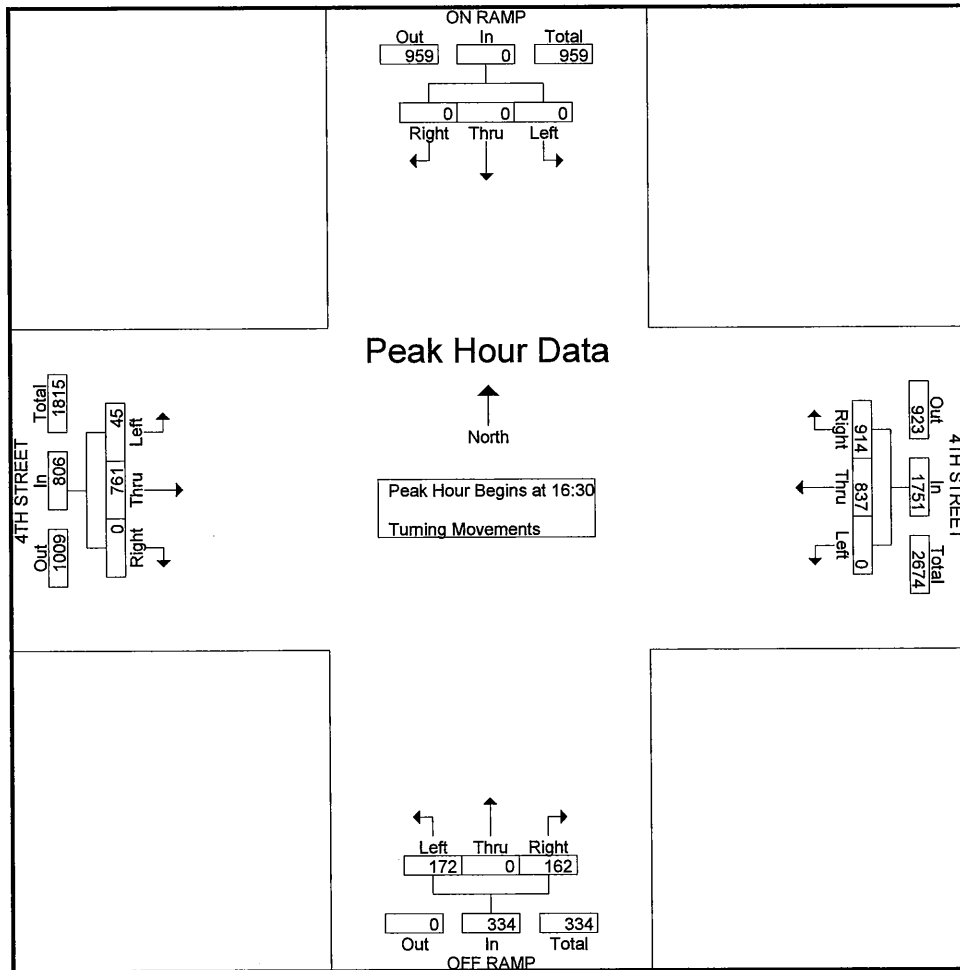

City: SANTA ANA
 N-S Direction: CABRILLO PARK DRIVE
 E-W Direction: 4TH STREET

File Name : H1610028
 Site Code : 00000000
 Start Date : 10/4/2016
 Page No : 1

Groups Printed- Turning Movements

Start Time	CABRILLO PARK DRIVE Southbound			4TH STREET Westbound			CABRILLO PARK DRIVE Northbound			4TH STREET Eastbound			Int. Total
	Right	Thru	Left	Right	Thru	Left	Right	Thru	Left	Right	Thru	Left	
07:00	32	55	44	5	99	9	3	17	45	45	104	17	475
07:15	59	113	57	5	126	11	7	26	46	64	149	30	693
07:30	60	91	67	19	170	14	6	25	48	38	169	40	747
07:45	60	125	48	17	168	17	7	27	56	53	196	43	817
Total	211	384	216	46	563	51	23	95	195	200	618	130	2732
08:00	46	102	53	16	157	12	16	24	50	63	159	45	743
08:15	36	76	59	20	159	14	8	32	31	51	174	42	702
08:30	44	84	46	13	140	11	10	24	36	50	158	42	658
08:45	43	63	25	18	105	5	10	29	52	49	150	41	590
Total	169	325	183	67	561	42	44	109	169	213	641	170	2693
*** BREAK ***													
16:00	34	31	25	36	328	9	24	61	106	12	126	51	843
16:15	34	43	28	29	289	10	13	69	77	14	140	44	790
16:30	30	36	18	37	287	7	40	75	118	12	149	55	864
16:45	30	42	21	30	297	9	14	57	94	13	162	49	818
Total	128	152	92	132	1201	35	91	262	395	51	577	199	3315
17:00	37	46	28	36	334	13	17	92	141	9	177	64	994
17:15	39	47	31	29	281	12	18	92	95	12	160	49	865
17:30	28	40	25	50	260	5	16	85	102	6	129	59	805
17:45	46	50	20	33	262	11	12	89	76	4	120	55	778
Total	150	183	104	148	1137	41	63	358	414	31	586	227	3442
Grand Total	658	1044	595	393	3462	169	221	824	1173	495	2422	726	12182
Apprch %	28.6	45.5	25.9	9.8	86	4.2	10	37.2	52.9	13.6	66.5	19.9	
Total %	5.4	8.6	4.9	3.2	28.4	1.4	1.8	6.8	9.6	4.1	19.9	6	

City: SANTA ANA
 N-S Direction: CABRILLO PARK DRIVE
 E-W Direction: 4TH STREET

File Name : H1610028
 Site Code : 00000000
 Start Date : 10/4/2016
 Page No : 2

Start Time	CABRILLO PARK DRIVE Southbound				4TH STREET Westbound				CABRILLO PARK DRIVE Northbound				4TH STREET Eastbound				Int. Total
	Right	Thru	Left	App. Total	Right	Thru	Left	App. Total	Right	Thru	Left	App. Total	Right	Thru	Left	App. Total	
Peak Hour Analysis From 07:00 to 08:45 - Peak 1 of 1																	
Peak Hour for Entire Intersection Begins at 07:30																	
07:30	60	91	67	218	19	170	14	203	6	25	48	79	38	169	40	247	747
07:45	60	125	48	233	17	168	17	202	7	27	56	90	53	196	43	292	817
08:00	46	102	53	201	16	157	12	185	16	24	50	90	63	159	45	267	743
08:15	36	76	59	171	20	159	14	193	8	32	31	71	51	174	42	267	702
Total Volume	202	394	227	823	72	654	57	783	37	108	185	330	205	698	170	1073	3009
% App. Total	24.5	47.9	27.6		9.2	83.5	7.3		11.2	32.7	56.1		19.1	65.1	15.8		
PHF	.842	.788	.847	.883	.900	.962	.838	.964	.578	.844	.826	.917	.813	.890	.944	.919	.921

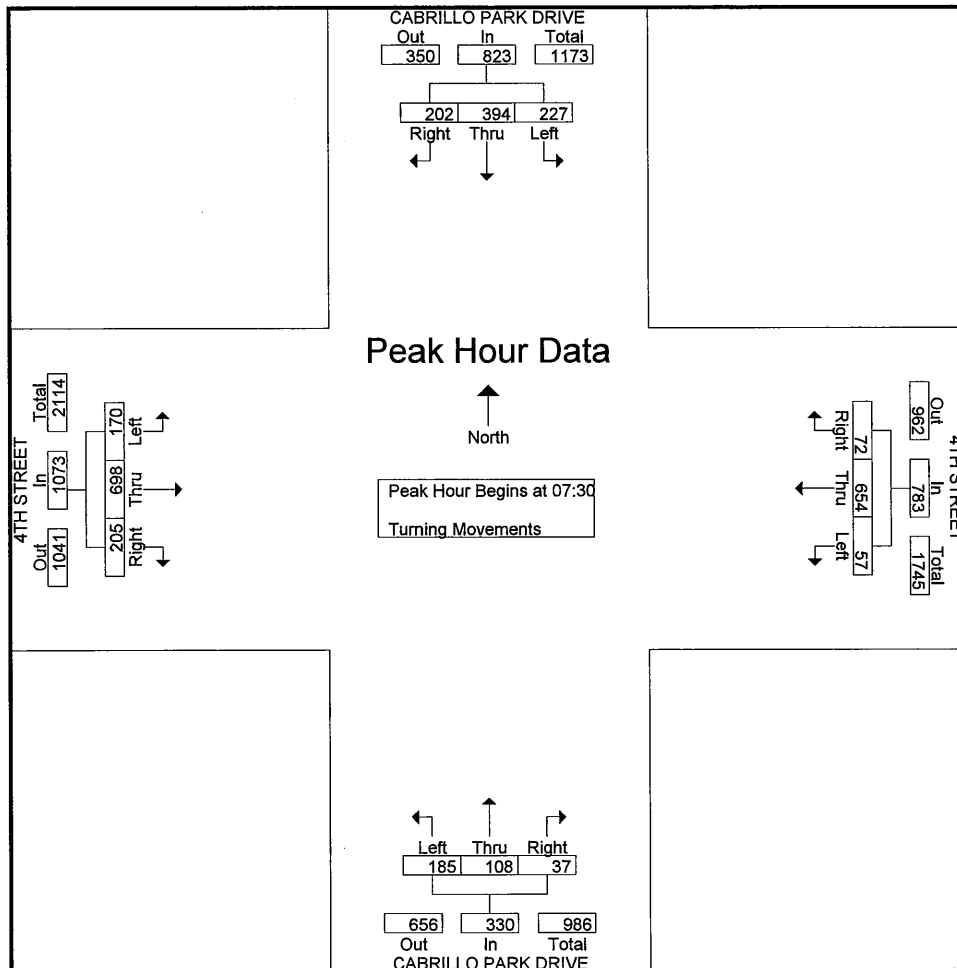

City: SANTA ANA
 N-S Direction: CABRILLO PARK DRIVE
 E-W Direction: 4TH STREET

File Name : H1610028
 Site Code : 0000000
 Start Date : 10/4/2016
 Page No : 3

Start Time	CABRILLO PARK DRIVE Southbound				4TH STREET Westbound				CABRILLO PARK DRIVE Northbound				4TH STREET Eastbound				Int. Total
	Right	Thru	Left	App. Total	Right	Thru	Left	App. Total	Right	Thru	Left	App. Total	Right	Thru	Left	App. Total	
Peak Hour Analysis From 16:00 to 17:45 - Peak 1 of 1																	
Peak Hour for Entire Intersection Begins at 16:30																	
16:30	30	36	18	84	37	287	7	331	40	75	118	233	12	149	55	216	864
16:45	30	42	21	93	30	297	9	336	14	57	94	165	13	162	49	224	818
17:00	37	46	28	111	36	334	13	383	17	92	141	250	9	177	64	250	994
17:15	39	47	31	117	29	281	12	322	18	92	95	205	12	160	49	221	865
Total Volume	136	171	98	405	132	1199	41	1372	89	316	448	853	46	648	217	911	3541
% App. Total	33.6	42.2	24.2		9.6	87.4	3		10.4	37	52.5		5	71.1	23.8		
PHF	.872	.910	.790	.865	.892	.897	.788	.896	.556	.859	.794	.853	.885	.915	.848	.911	.891

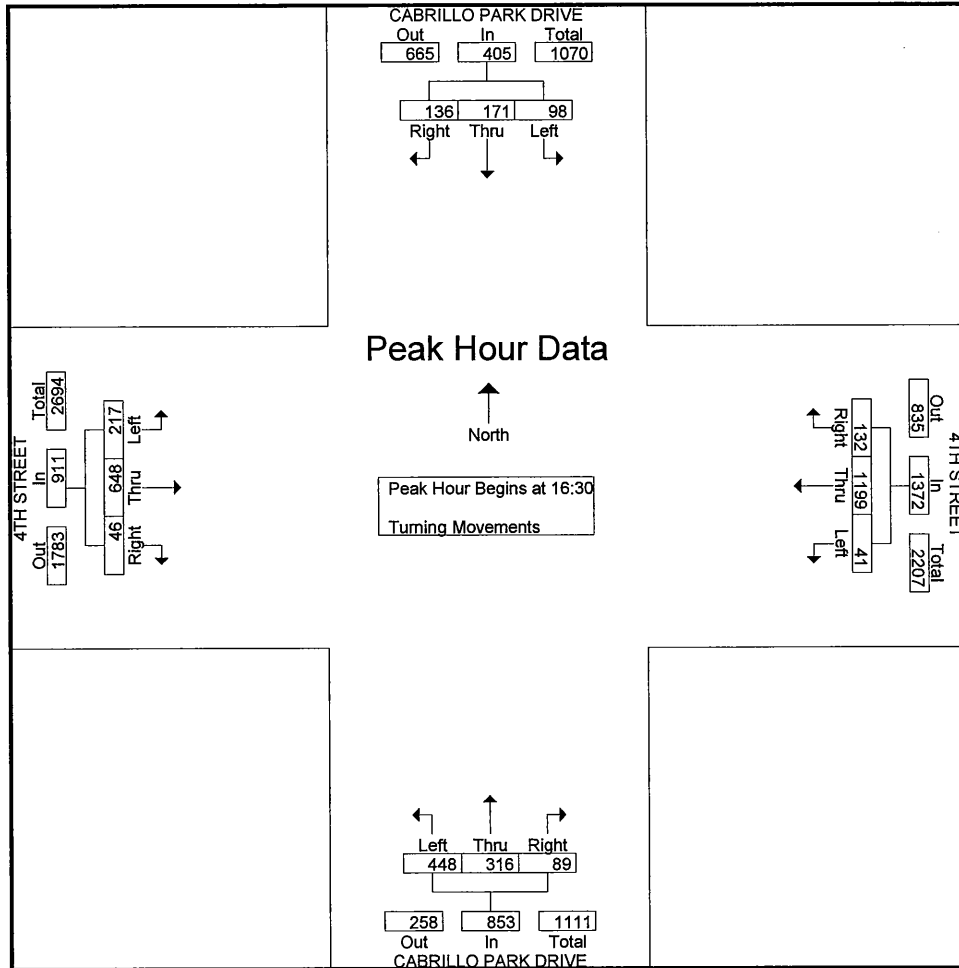

City: SANTA ANA
 N-S Direction: GOLDEN CIRCLE DRIVE
 E-W Direction: 4TH STREET

File Name : H1610029
 Site Code : 00000000
 Start Date : 10/4/2016
 Page No : 1

Groups Printed- Turning Movements

Start Time	GOLDEN CIRCLE DRIVE Southbound			4TH STREET Westbound			GOLDEN CIRCLE DRIVE Northbound			4TH STREET Eastbound			Int. Total
	Right	Thru	Left	Right	Thru	Left	Right	Thru	Left	Right	Thru	Left	
07:00	0	0	2	2	105	15	4	0	2	20	130	3	283
07:15	1	0	0	3	145	10	13	0	0	30	185	1	388
07:30	2	0	1	4	192	20	13	1	14	20	216	3	486
07:45	1	1	0	5	198	24	24	0	5	16	229	2	505
Total	4	1	3	14	640	69	54	1	21	86	760	9	1662
08:00	2	0	1	5	175	20	13	3	15	12	202	3	451
08:15	2	2	1	4	198	30	12	1	4	28	183	4	469
08:30	2	0	4	9	166	23	9	4	9	19	186	6	437
08:45	3	0	1	7	139	20	18	3	3	22	146	5	367
Total	9	2	7	25	678	93	52	11	31	81	717	18	1724
*** BREAK ***													
16:00	27	6	12	6	296	14	39	2	40	10	154	4	610
16:15	12	1	16	5	270	13	29	0	33	7	177	1	564
16:30	4	1	5	4	284	12	39	1	43	9	187	1	590
16:45	5	3	7	6	278	12	43	1	43	11	184	3	596
Total	48	11	40	21	1128	51	150	4	159	37	702	9	2360
17:00	14	1	10	6	312	11	52	0	56	18	207	1	688
17:15	8	1	8	3	242	12	34	1	40	15	192	4	560
17:30	5	2	7	2	275	9	46	2	32	16	161	4	561
17:45	8	1	8	3	253	6	28	2	29	7	138	5	488
Total	35	5	33	14	1082	38	160	5	157	56	698	14	2297
Grand Total	96	19	83	74	3528	251	416	21	368	260	2877	50	8043
Apprch %	48.5	9.6	41.9	1.9	91.6	6.5	51.7	2.6	45.7	8.2	90.3	1.6	
Total %	1.2	0.2	1	0.9	43.9	3.1	5.2	0.3	4.6	3.2	35.8	0.6	

City: SANTA ANA
 N-S Direction: GOLDEN CIRCLE DRIVE
 E-W Direction: 4TH STREET

File Name : H1610029
 Site Code : 00000000
 Start Date : 10/4/2016
 Page No : 2

Start Time	GOLDEN CIRCLE DRIVE Southbound				4TH STREET Westbound				GOLDEN CIRCLE DRIVE Northbound				4TH STREET Eastbound				Int. Total
	Right	Thru	Left	App. Total	Right	Thru	Left	App. Total	Right	Thru	Left	App. Total	Right	Thru	Left	App. Total	
Peak Hour Analysis From 07:00 to 08:45 - Peak 1 of 1																	
Peak Hour for Entire Intersection Begins at 07:30																	
07:30	2	0	1	3	4	192	20	216	13	1	14	28	20	216	3	239	486
07:45	1	1	0	2	5	198	24	227	24	0	5	29	16	229	2	247	505
08:00	2	0	1	3	5	175	20	200	13	3	15	31	12	202	3	217	451
08:15	2	2	1	5	4	198	30	232	12	1	4	17	28	183	4	215	469
Total Volume	7	3	3	13	18	763	94	875	62	5	38	105	76	830	12	918	1911
% App. Total	53.8	23.1	23.1		2.1	87.2	10.7		59	4.8	36.2		8.3	90.4	1.3		
PHF	.875	.375	.750	.650	.900	.963	.783	.943	.646	.417	.633	.847	.679	.906	.750	.929	.946

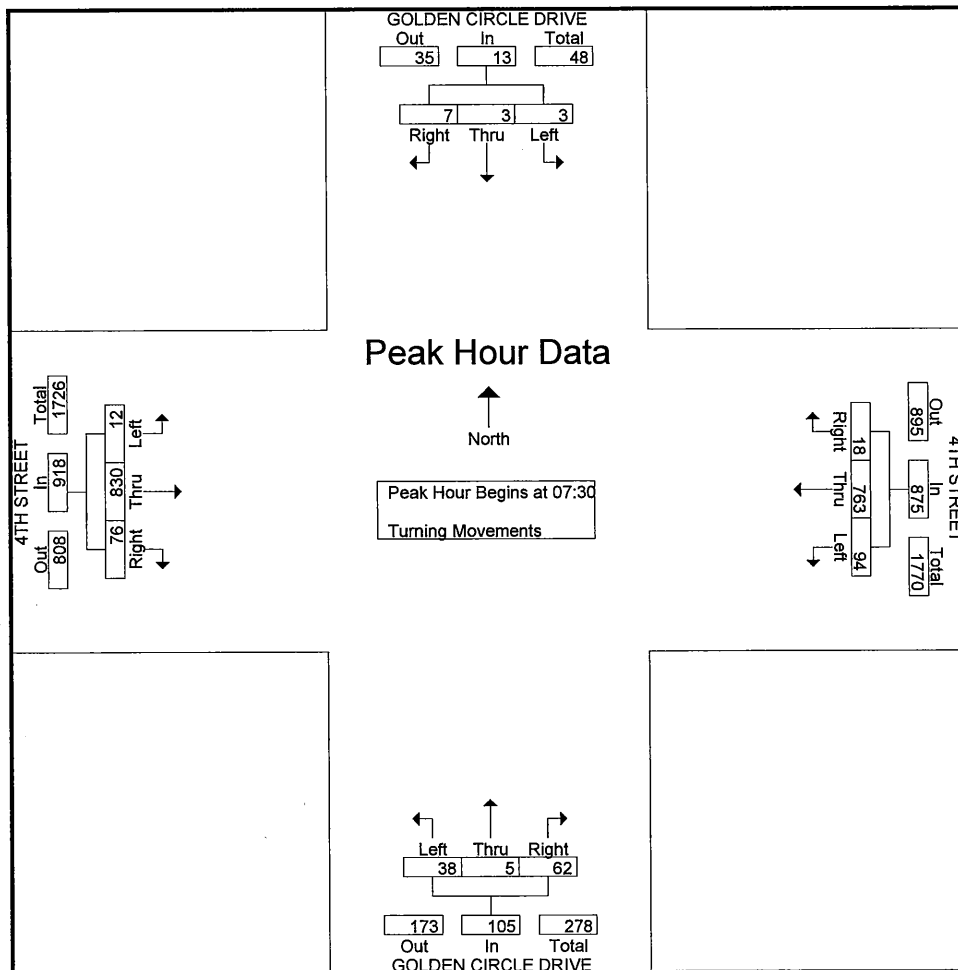

City: SANTA ANA
 N-S Direction: GOLDEN CIRCLE DRIVE
 E-W Direction: 4TH STREET

File Name : H1610029
 Site Code : 0000000
 Start Date : 10/4/2016
 Page No : 3

Start Time	GOLDEN CIRCLE DRIVE Southbound				4TH STREET Westbound				GOLDEN CIRCLE DRIVE Northbound				4TH STREET Eastbound				Int. Total
	Right	Thru	Left	App. Total	Right	Thru	Left	App. Total	Right	Thru	Left	App. Total	Right	Thru	Left	App. Total	
Peak Hour Analysis From 16:00 to 17:45 - Peak 1 of 1																	
Peak Hour for Entire Intersection Begins at 16:15																	
16:15	12	1	16	29	5	270	13	288	29	0	33	62	7	177	1	185	564
16:30	4	1	5	10	4	284	12	300	39	1	43	83	9	187	1	197	590
16:45	5	3	7	15	6	278	12	296	43	1	43	87	11	184	3	198	596
17:00	14	1	10	25	6	312	11	329	52	0	56	108	18	207	1	226	688
Total Volume	35	6	38	79	21	1144	48	1213	163	2	175	340	45	755	6	806	2438
% App. Total	44.3	7.6	48.1		1.7	94.3	4		47.9	0.6	51.5		5.6	93.7	0.7		
PHF	.625	.500	.594	.681	.875	.917	.923	.922	.784	.500	.781	.787	.625	.912	.500	.892	.886

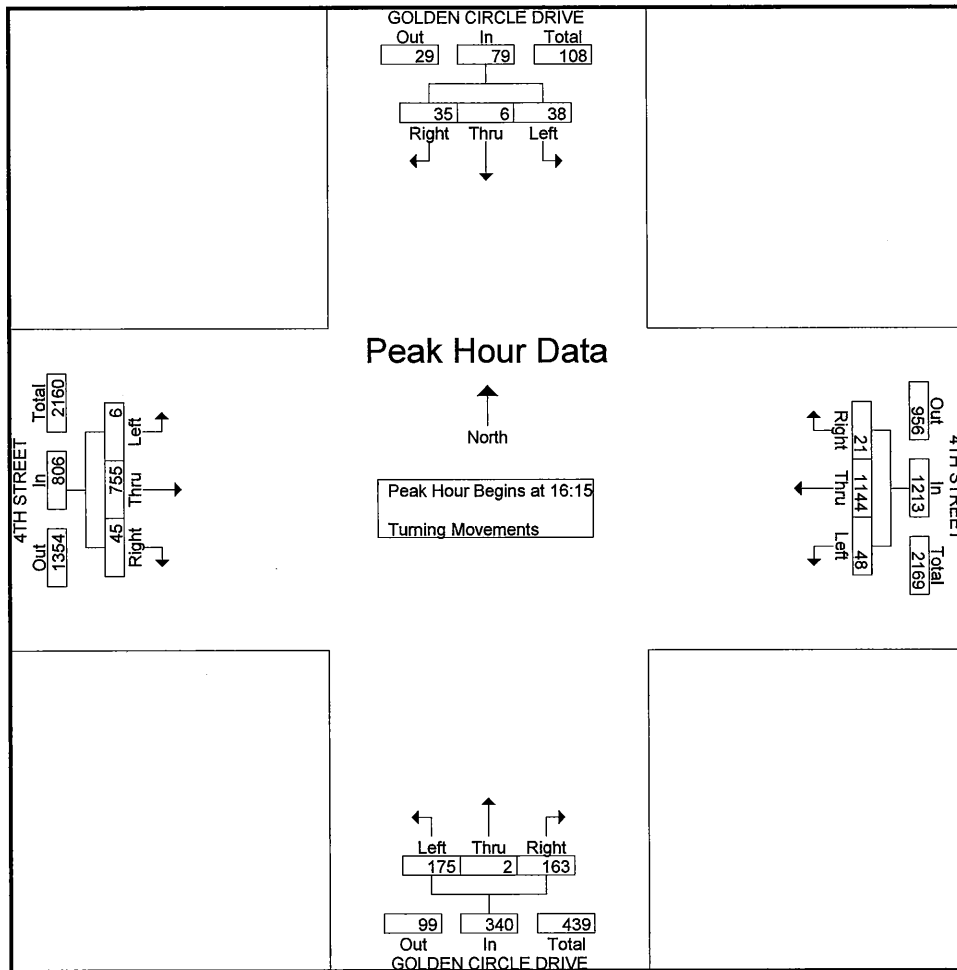

City: SANTA ANA
 N-S Direction: PARK CENTER DRIVE
 E-W Direction: 4TH STREET

File Name : H1610030
 Site Code : 00000000
 Start Date : 10/4/2016
 Page No : 1

Groups Printed- Turning Movements

Start Time	PARK CENTER DRIVE Southbound			4TH STREET Westbound				DEAD END Northbound			4TH STREET Eastbound				Int. Total
	Right	Thru	Left	Right	Thru	Left	U-Turn	Right	Thru	Left	Right	Thru	Left	U-Turn	
07:00	14	0	0	8	119	0	0	0	0	0	0	116	10	0	267
07:15	16	0	0	17	160	0	0	0	0	0	0	185	12	3	393
07:30	35	0	0	27	221	0	0	0	0	0	0	210	13	0	506
07:45	25	0	0	28	242	0	0	0	0	0	0	234	28	3	560
Total	90	0	0	80	742	0	0	0	0	0	0	745	63	6	1726
08:00	19	0	0	23	207	0	0	0	0	0	0	204	23	6	482
08:15	24	0	0	22	217	0	0	0	0	0	0	191	21	8	483
08:30	21	0	0	27	203	0	0	0	0	0	0	151	20	4	426
08:45	11	0	0	25	176	0	0	0	0	0	0	147	17	4	380
Total	75	0	0	97	803	0	0	0	0	0	0	693	81	22	1771
*** BREAK ***															
16:00	31	0	0	12	301	0	0	0	0	0	0	210	15	11	580
16:15	21	0	0	15	270	0	0	0	0	0	0	209	13	9	537
16:30	18	0	0	23	292	0	0	0	0	0	0	218	28	10	589
16:45	26	0	0	22	280	0	0	0	0	0	0	214	17	5	564
Total	96	0	0	72	1143	0	0	0	0	0	0	851	73	35	2270
17:00	35	0	0	13	304	0	0	0	0	0	0	258	20	11	641
17:15	17	0	0	17	233	0	0	0	0	0	0	232	20	9	528
17:30	34	0	0	20	254	0	0	0	0	0	0	202	16	4	530
17:45	33	0	0	9	238	0	0	0	0	0	0	162	18	5	465
Total	119	0	0	59	1029	0	0	0	0	0	0	854	74	29	2164
Grand Total	380	0	0	308	3717	0	0	0	0	0	0	3143	291	92	7931
Apprch %	100	0	0	7.7	92.3	0	0	0	0	0	0	89.1	8.3	2.6	
Total %	4.8	0	0	3.9	46.9	0	0	0	0	0	0	39.6	3.7	1.2	

City: SANTA ANA
 N-S Direction: PARK CENTER DRIVE
 E-W Direction: 4TH STERET

File Name : H1610030
 Site Code : 0000000
 Start Date : 10/4/2016
 Page No : 2

Start Time	PARK CENTER DRIVE Southbound				4TH STREET Westbound					DEAD END Northbound				4TH STREET Eastbound					Int. Total
	Right	Thru	Left	App. Total	Right	Thru	Left	U-Turn	App. Total	Right	Thru	Left	App. Total	Right	Thru	Left	U-Turn	App. Total	
Peak Hour Analysis From 07:00 to 07:45 - Peak 1 of 1																			
Peak Hour for Entire Intersection Begins at 07:00																			
07:00	14	0	0	14	8	119	0	0	127	0	0	0	0	0	116	10	0	126	267
07:15	16	0	0	16	17	160	0	0	177	0	0	0	0	0	185	12	3	200	384
07:30	35	0	0	35	27	221	0	0	248	0	0	0	0	0	210	13	0	223	606
07:45	25	0	0	25	28	242	0	0	270	0	0	0	0	0	234	28	3	265	560
Total Volume	90	0	0	90	80	742	0	0	822	0	0	0	0	0	745	63	6	814	1726
% App. Total	100	0	0		9.7	90.3	0	0		0	0	0		0	91.5	7.7	0.7		
PHF	.643	.000	.000	.643	.714	.767	.000	.000	.761	.000	.000	.000	.000	.000	.796	.563	.500	.768	.771

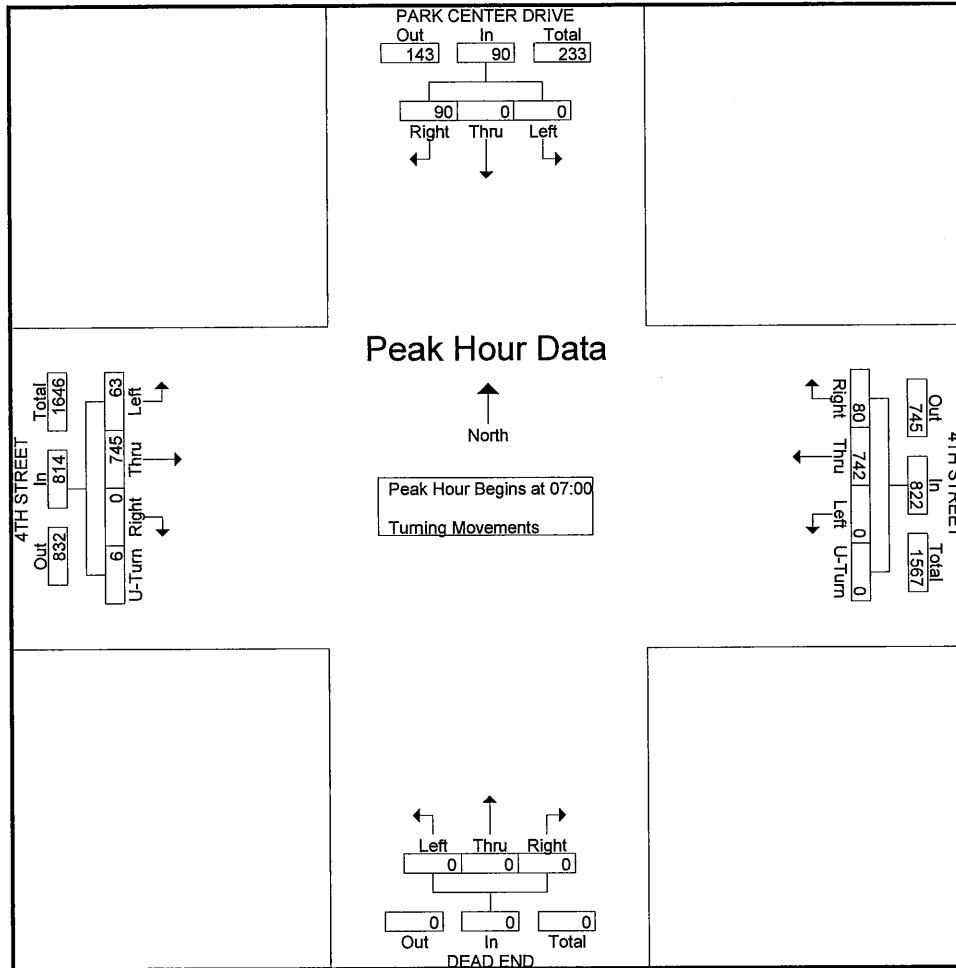

City: SANTA ANA
 N-S Direction: PARK CENTER DRIVE
 E-W Direction: 4TH STERET

File Name : H1610030
 Site Code : 00000000
 Start Date : 10/4/2016
 Page No : 3

Start Time	PARK CENTER DRIVE Southbound				4TH STREET Westbound					DEAD END Northbound				4TH STREET Eastbound					Int. Total
	Right	Thru	Left	App. Total	Right	Thru	Left	U-Turn	App. Total	Right	Thru	Left	App. Total	Right	Thru	Left	U-Turn	App. Total	
Peak Hour Analysis From 16:00 to 17:45 - Peak 1 of 1																			
Peak Hour for Entire Intersection Begins at 16:15																			
16:15	21	0	0	21	15	270	0	0	285	0	0	0	0	0	209	13	9	231	537
16:30	18	0	0	18	22	280	0	0	302	0	0	0	0	0	214	28	5	236	564
16:45	26	0	0	26	13	304	0	0	317	0	0	0	0	0	258	20	11	289	641
17:00	35	0	0	35															
Total Volume	100	0	0	100	73	1146	0	0	1219	0	0	0	0	0	899	78	35	1012	2331
% App. Total	100	0	0		6	94	0	0		0	0	0		0	88.8	7.7	3.5		
PHF	.714	.000	.000	.714	.793	.942	.000	.000	.961	.000	.000	.000	.000	.000	.871	.696	.795	.875	.909

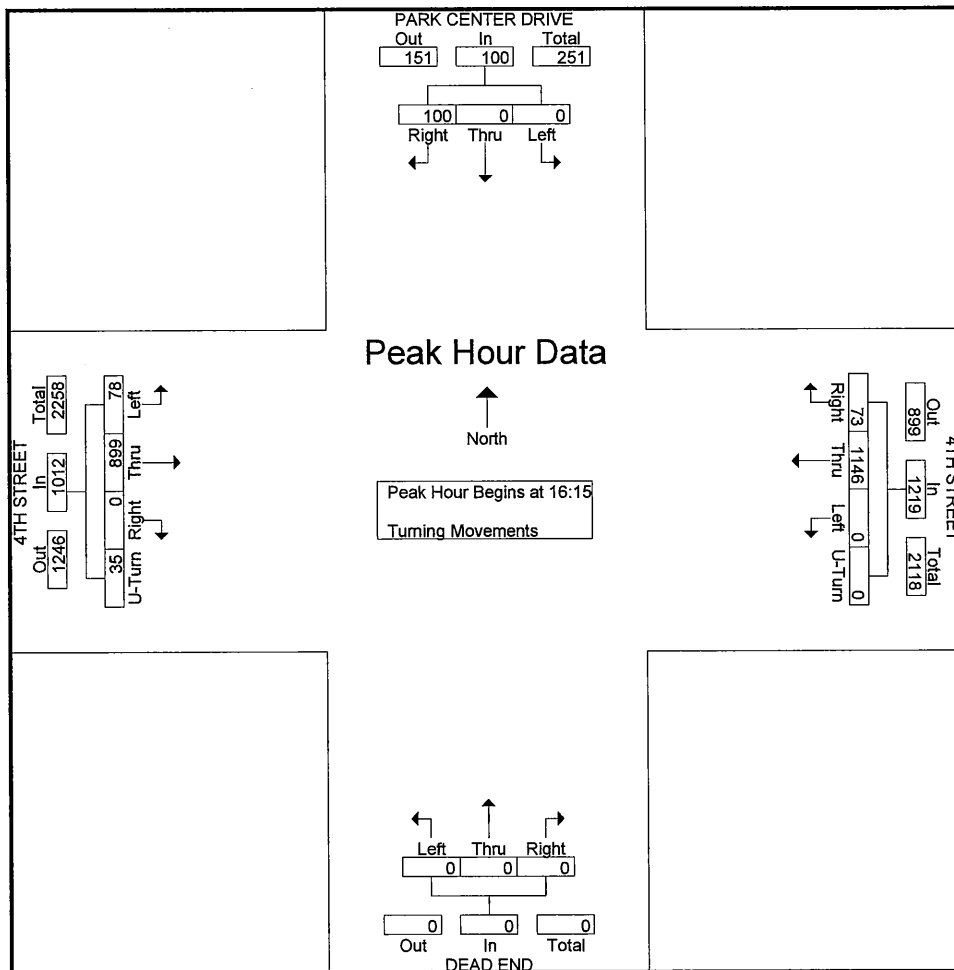

City: SANTA ANA
 N-S Direction: TUSTIN AVENUE
 E-W Direction: 4TH STREET

File Name : H1610031
 Site Code : 00000000
 Start Date : 10/4/2016
 Page No : 1

Groups Printed- Turning Movements

Start Time	TUSTIN AVENUE Southbound			4TH STREET Westbound				TUSTIN AVENUE Northbound			4TH STREET Eastbound				Int. Total
	Right	Thru	Left	Right	Thru	Left	U-Turn	Right	Thru	Left	Right	Thru	Left	U-Turn	
07:00	38	186	190	42	96	9	1	49	52	6	2	106	8	1	786
07:15	53	244	167	49	135	13	4	55	33	8	5	163	19	2	950
07:30	65	286	128	52	181	12	13	54	40	15	2	216	17	1	1082
07:45	77	258	114	85	181	18	10	57	70	20	8	188	35	3	1124
Total	233	974	599	228	593	52	28	215	195	49	17	673	79	7	3942
08:00	71	238	119	85	145	24	14	61	87	15	11	164	23	2	1059
08:15	55	223	125	118	185	25	7	69	68	12	13	124	34	0	1058
08:30	59	206	150	104	161	21	5	41	64	7	6	111	30	1	966
08:45	51	162	145	95	152	19	1	55	70	12	12	81	26	4	885
Total	236	829	539	402	643	89	27	226	289	46	42	480	113	7	3968
*** BREAK ***															
16:00	36	82	90	85	241	35	4	48	142	26	11	159	48	5	1012
16:15	21	71	92	91	240	29	3	43	152	17	10	160	47	7	983
16:30	39	88	111	77	237	23	6	58	170	26	10	174	52	3	1074
16:45	33	79	93	92	237	29	6	46	161	23	13	166	47	7	1032
Total	129	320	386	345	955	116	19	195	625	92	44	659	194	22	4101
17:00	46	106	105	96	210	24	6	55	204	16	13	210	56	3	1150
17:15	37	106	111	86	188	23	10	59	171	25	18	177	54	5	1070
17:30	31	133	129	118	191	16	6	57	186	30	15	167	49	3	1131
17:45	31	92	79	96	189	15	5	46	231	8	10	133	34	1	970
Total	145	437	424	396	778	78	27	217	792	79	56	687	193	12	4321
Grand Total	743	2560	1948	1371	2969	335	101	853	1901	266	159	2499	579	48	16332
Apprch %	14.1	48.8	37.1	28.7	62.2	7	2.1	28.2	62.9	8.8	4.8	76.1	17.6	1.5	
Total %	4.5	15.7	11.9	8.4	18.2	2.1	0.6	5.2	11.6	1.6	1	15.3	3.5	0.3	

City: SANTA ANA
 N-S Direction: TUSTIN AVENUE
 E-W Direction: 4TH STREET

File Name : H1610031
 Site Code : 0000000
 Start Date : 10/4/2016
 Page No : 2

Start Time	TUSTIN AVENUE Southbound				4TH STREET Westbound					TUSTIN AVENUE Northbound				4TH STREET Eastbound					Int. Total
	Right	Thru	Left	App. Total	Right	Thru	Left	U-Turn	App. Total	Right	Thru	Left	App. Total	Right	Thru	Left	U-Turn	App. Total	
Peak Hour Analysis From 07:00 to 07:45 - Peak 1 of 1																			
Peak Hour for Entire Intersection Begins at 07:00																			
07:00	38	186	180																
07:15	53	244	167	464	49	135	13	4	201	55	33	8	96	5	163	19	2	189	950
07:30	65	296	128	479	62	181	12	13	258	54	40	15	109	2	216	17	1	236	
07:45	77	258	114	449	85	181	18	10	294	57	70	20	147	8	188	35	3	234	1124
Total Volume	233	974	599	1806	228	593	52	28	901	215	195	49	459	17	673	79	7	776	3942
% App. Total	12.9	53.9	33.2		25.3	65.8	5.8	3.1		46.8	42.5	10.7		2.2	86.7	10.2	0.9		
PHF	.756	.851	.788	.943	.671	.819	.722	.538	.766	.943	.696	.613	.781	.531	.779	.564	.583	.822	.877

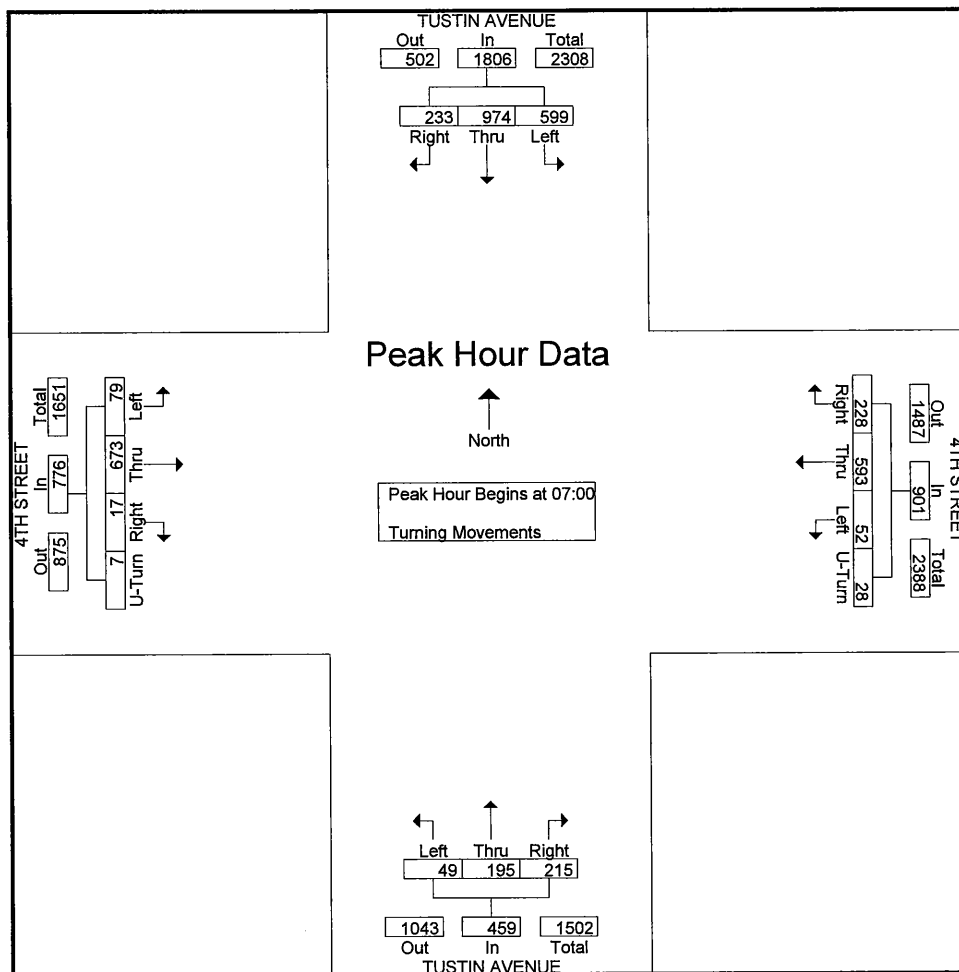

City: SANTA ANA
 N-S Direction: TUSTIN AVENUE
 E-W Direction: 4TH STREET

File Name : H1610031
 Site Code : 00000000
 Start Date : 10/4/2016
 Page No : 3

Start Time	TUSTIN AVENUE Southbound				4TH STREET Westbound					TUSTIN AVENUE Northbound				4TH STREET Eastbound					Int. Total
	Right	Thru	Left	App. Total	Right	Thru	Left	U-Turn	App. Total	Right	Thru	Left	App. Total	Right	Thru	Left	U-Turn	App. Total	
16:45	33	79	93	205	92	237	29	6	364	46	181	23	230	13	166	47	7		
17:00	46	106	105	257	96	210	24	6	336	55	204	16	275	13	210	56	3	282	1150
17:15	37	106	111	254	86	188	23	10	307	59	171	25	255	18	177	54	5	254	1070
17:30	31	133	129	293	118	191	16	6	331	57	186	30	273	15	167	49	3	234	1131
Total Volume	147	424	438	1009	392	826	92	28	1338	217	722	94	1033	59	720	206	18	1003	4383
% App. Total	14.6	42	43.4		29.3	61.7	6.9	2.1		21	69.9	9.1		5.9	71.8	20.5	1.8		
PHF	.799	.797	.849	.861	.831	.871	.793	.700	.919	.919	.885	.783	.939	.819	.857	.920	.643	.889	.953

Peak Hour Analysis From 16:00 to 17:45 - Peak 1 of 1
 Peak Hour for Entire Intersection Begins at 16:45

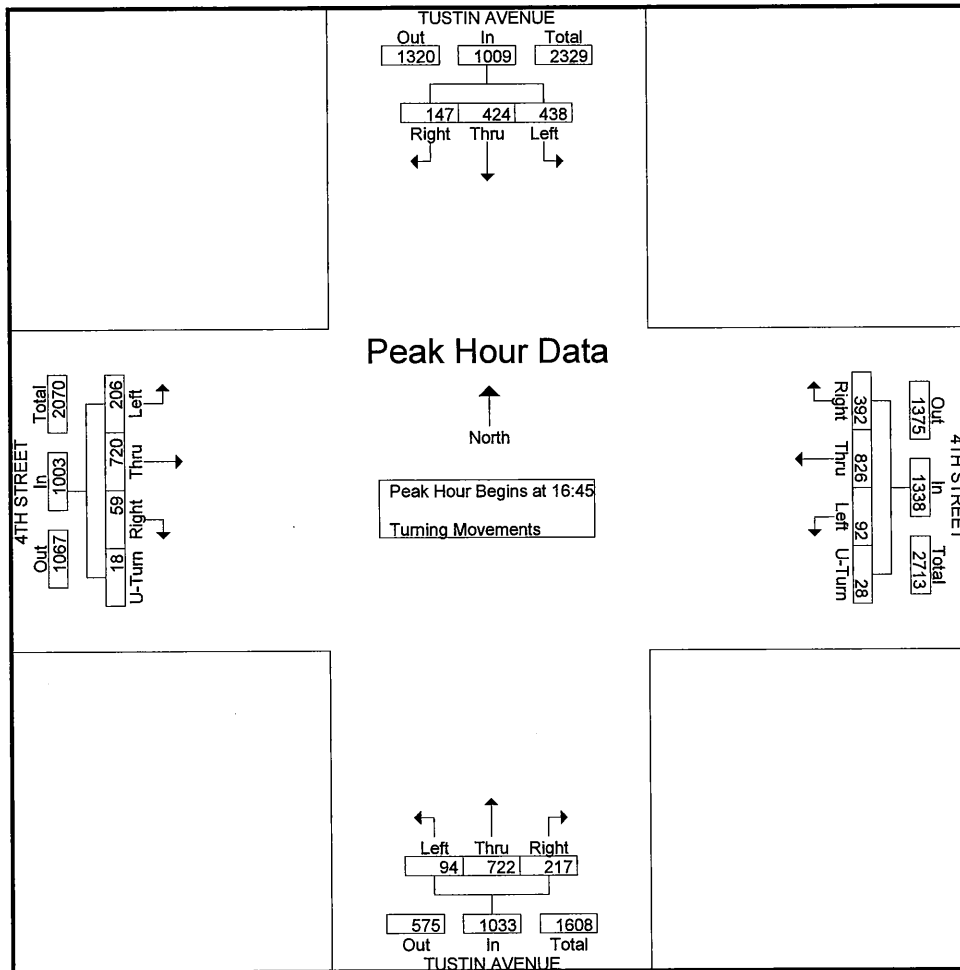

City: SANTA ANA
 N-S Direction: SR-55 SB RAMPS
 E-W Direction: 4TH STREET

File Name : H1610032
 Site Code : 00000000
 Start Date : 10/4/2016
 Page No : 1

Groups Printed- Turning Movements

Start Time	OFF RAMP Southbound			4TH STREET Westbound			ON RAMP Northbound			4TH STREET Eastbound			Int. Total
	Right	Thru	Left	Right	Thru	Left	Right	Thru	Left	Right	Thru	Left	
07:00	17	0	29	0	137	118	0	0	0	239	102	0	642
07:15	15	0	18	0	193	135	0	0	0	253	120	0	734
07:30	13	0	10	0	254	130	0	0	0	255	141	0	803
07:45	18	0	17	0	286	131	0	0	0	235	142	0	829
Total	63	0	74	0	870	514	0	0	0	982	505	0	3008
08:00	17	0	9	0	252	115	0	0	0	241	124	0	758
08:15	33	0	16	0	316	134	0	0	0	217	102	0	818
08:30	27	0	16	0	284	118	0	0	0	177	115	0	737
08:45	27	0	33	0	243	120	0	0	0	180	100	0	703
Total	104	0	74	0	1095	487	0	0	0	815	441	0	3016
*** BREAK ***													
16:00	87	0	75	0	282	93	0	0	0	108	192	0	837
16:15	92	0	117	0	281	71	0	0	0	109	191	0	861
16:30	71	0	112	0	291	81	0	0	0	117	215	0	887
16:45	81	0	138	0	272	70	0	0	0	122	195	0	878
Total	331	0	442	0	1126	315	0	0	0	456	793	0	3463
17:00	56	0	101	0	286	89	0	0	0	157	222	0	911
17:15	62	0	132	0	235	97	0	0	0	153	201	0	880
17:30	45	0	98	0	298	102	0	0	0	158	202	0	903
17:45	52	0	96	0	264	83	0	0	0	101	153	0	749
Total	215	0	427	0	1083	371	0	0	0	569	778	0	3443
Grand Total	713	0	1017	0	4174	1687	0	0	0	2822	2517	0	12930
Approch %	41.2	0	58.8	0	71.2	28.8	0	0	0	52.9	47.1	0	
Total %	5.5	0	7.9	0	32.3	13	0	0	0	21.8	19.5	0	

City: SANTA ANA
 N-S Direction: SR-55 SB RAMPS
 E-W Direction: 4TH STREET

File Name : H1610032
 Site Code : 00000000
 Start Date : 10/4/2016
 Page No : 2

Start Time	OFF RAMP Southbound				4TH STREET Westbound				ON RAMP Northbound				4TH STREET Eastbound				Int. Total
	Right	Thru	Left	App. Total	Right	Thru	Left	App. Total	Right	Thru	Left	App. Total	Right	Thru	Left	App. Total	
Peak Hour Analysis From 07:00 to 08:45 - Peak 1 of 1																	
Peak Hour for Entire Intersection Begins at 07:30																	
07:30	13	0	10	23	0	254	130	384	0	0	0	0	255	141	0	396	803
07:45	18	0	17	35	0	286	131	417	0	0	0	0	235	142	0	377	829
08:00	17	0	9	26	0	252	115	367	0	0	0	0	241	124	0	365	758
08:15	33	0	16	49	0	316	134	450	0	0	0	0	217	102	0	319	818
Total Volume	81	0	52	133	0	1108	510	1618	0	0	0	0	948	509	0	1457	3208
% App. Total	60.9	0	39.1		0	68.5	31.5		0	0	0		65.1	34.9	0		
PHF	.614	.000	.765	.679	.000	.877	.951	.899	.000	.000	.000	.000	.929	.896	.000	.920	.967

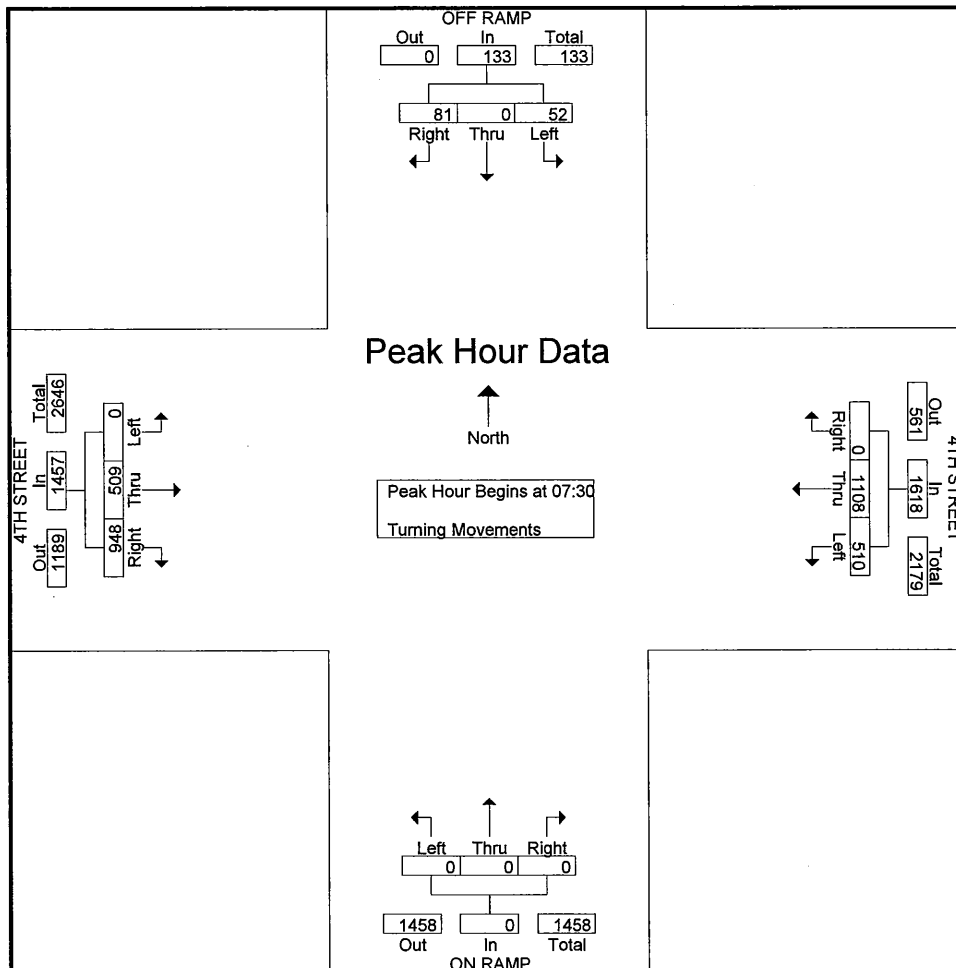

City: SANTA ANA
 N-S Direction: SR-55 SB RAMPS
 E-W Direction: 4TH STREET

File Name : H1610032
 Site Code : 00000000
 Start Date : 10/4/2016
 Page No : 3

Start Time	OFF RAMP Southbound				4TH STREET Westbound				ON RAMP Northbound				4TH STREET Eastbound				Int. Total
	Right	Thru	Left	App. Total	Right	Thru	Left	App. Total	Right	Thru	Left	App. Total	Right	Thru	Left	App. Total	
Peak Hour Analysis From 16:00 to 17:45 - Peak 1 of 1																	
Peak Hour for Entire Intersection Begins at 16:45																	
16:45	81	0	138	219	0	272	70	342	0	0	0	0	122	195	0	317	878
17:00	56	0	101	157	0	286	89	375	0	0	0	0	157	222	0	379	911
17:15	62	0	132	194	0	235	97	332	0	0	0	0	153	201	0	354	880
17:30	45	0	98	143	0	298	102	400	0	0	0	0	158	202	0	360	903
Total Volume	244	0	469	713	0	1091	358	1449	0	0	0	0	590	820	0	1410	3572
% App. Total	34.2	0	65.8		0	75.3	24.7		0	0	0		41.8	58.2	0		
PHF	.753	.000	.850	.814	.000	.915	.877	.906	.000	.000	.000	.000	.934	.923	.000	.930	.980

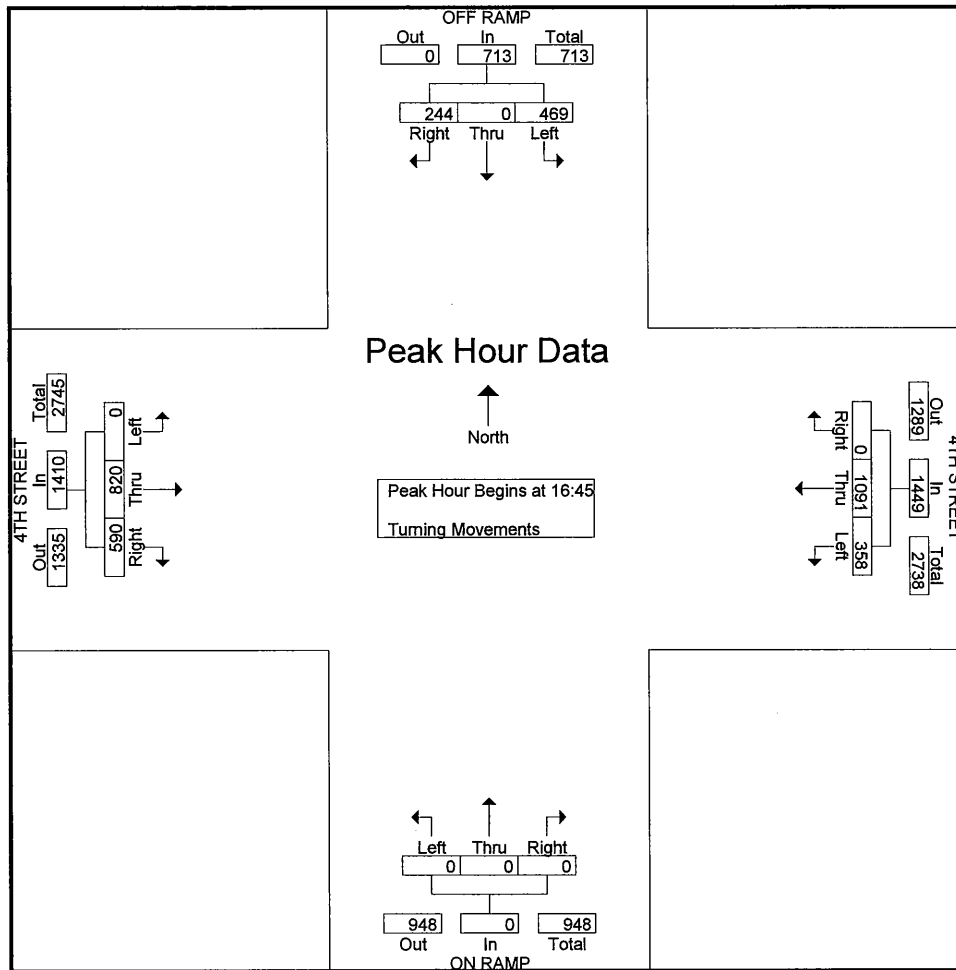

City: SANTA ANA
 N-S Direction: SR-55 NB RAMPS
 E-W Direction: 4TH STREET

File Name : H1610033
 Site Code : 00000000
 Start Date : 10/4/2016
 Page No : 1

Groups Printed- Turning Movements

Start Time	ON RAMP Southbound			4TH STREET Westbound			OFF RAMP Northbound			4TH STREET Eastbound				Int. Total
	Right	Thru	Left	Right	Thru	Left	Right	Thru	Left	Right	Thru	Left	U-Turn	
07:00	0	0	0	162	185	0	59	0	65	0	87	43	0	601
07:15	0	0	0	150	263	0	70	0	66	0	102	27	2	680
07:30	0	0	0	206	318	0	68	0	72	0	104	48	0	816
07:45	0	0	0	208	325	0	83	0	86	0	95	38	1	836
Total	0	0	0	726	1091	0	280	0	289	0	388	156	3	2933
08:00	0	0	0	229	273	0	79	0	109	0	95	35	1	821
08:15	0	0	0	202	318	0	79	0	113	0	79	39	1	831
08:30	0	0	0	163	285	0	74	0	137	0	99	31	1	790
08:45	0	0	0	146	240	0	111	0	107	0	96	37	1	738
Total	0	0	0	740	1116	0	343	0	466	0	369	142	4	3180
*** BREAK ***														
16:00	0	0	0	222	327	0	67	0	42	0	202	69	3	932
16:15	0	0	0	178	285	0	53	0	75	0	230	87	1	909
16:30	0	0	0	199	312	0	50	0	67	0	238	78	2	946
16:45	0	0	0	182	269	0	52	0	73	0	251	72	1	900
Total	0	0	0	781	1193	0	222	0	257	0	921	306	7	3687
17:00	0	0	0	216	295	0	75	0	64	0	249	69	6	974
17:15	0	0	0	186	285	0	74	0	78	0	251	85	2	961
17:30	0	0	0	160	272	0	70	0	116	0	236	64	4	922
17:45	0	0	0	179	268	0	77	0	85	0	197	47	8	861
Total	0	0	0	741	1120	0	296	0	343	0	933	265	20	3718
Grand Total	0	0	0	2988	4520	0	1141	0	1355	0	2611	869	34	13518
Apprch %	0	0	0	39.8	60.2	0	45.7	0	54.3	0	74.3	24.7	1	
Total %	0	0	0	22.1	33.4	0	8.4	0	10	0	19.3	6.4	0.3	

City: SANTA ANA
 N-S Direction: SR-55 NB RAMPS
 E-W Direction: 4TH STREET

File Name : H1610033
 Site Code : 00000000
 Start Date : 10/4/2016
 Page No : 2

Start Time	ON RAMP Southbound				4TH STREET Westbound				OFF RAMP Northbound				4TH STREET Eastbound					
	Right	Thru	Left	App. Total	Right	Thru	Left	App. Total	Right	Thru	Left	App. Total	Right	Thru	Left	U-Turn	App. Total	Int. Total
Peak Hour Analysis From 07:00 to 08:45 - Peak 1 of 1																		
Peak Hour for Entire Intersection Begins at 07:30																		
07:30	0	0	0	0	208	318	0	524	68	0	72	140	0	104	48	0	152	816
07:45	0	0	0	0	208	326	0	533	83	0	86	169	0	95	38	1	134	836
08:00	0	0	0	0	229	273	0	502	79	0	109	188	0	95	35	1	131	821
08:15	0	0	0	0	202	318	0	520	79	0	113	192	0	79	39	1	119	831
Total Volume	0	0	0	0	845	1234	0	2079	309	0	380	689	0	373	160	3	536	3304
% App. Total	0	0	0	0	40.6	59.4	0	44.8	44.8	0	55.2	89.7	0	69.6	29.9	0.6	88.2	98.8
PHF	.000	.000	.000	.000	.922	.949	.000	.975	.931	.000	.841	.897	.000	.897	.833	.750	.882	.988

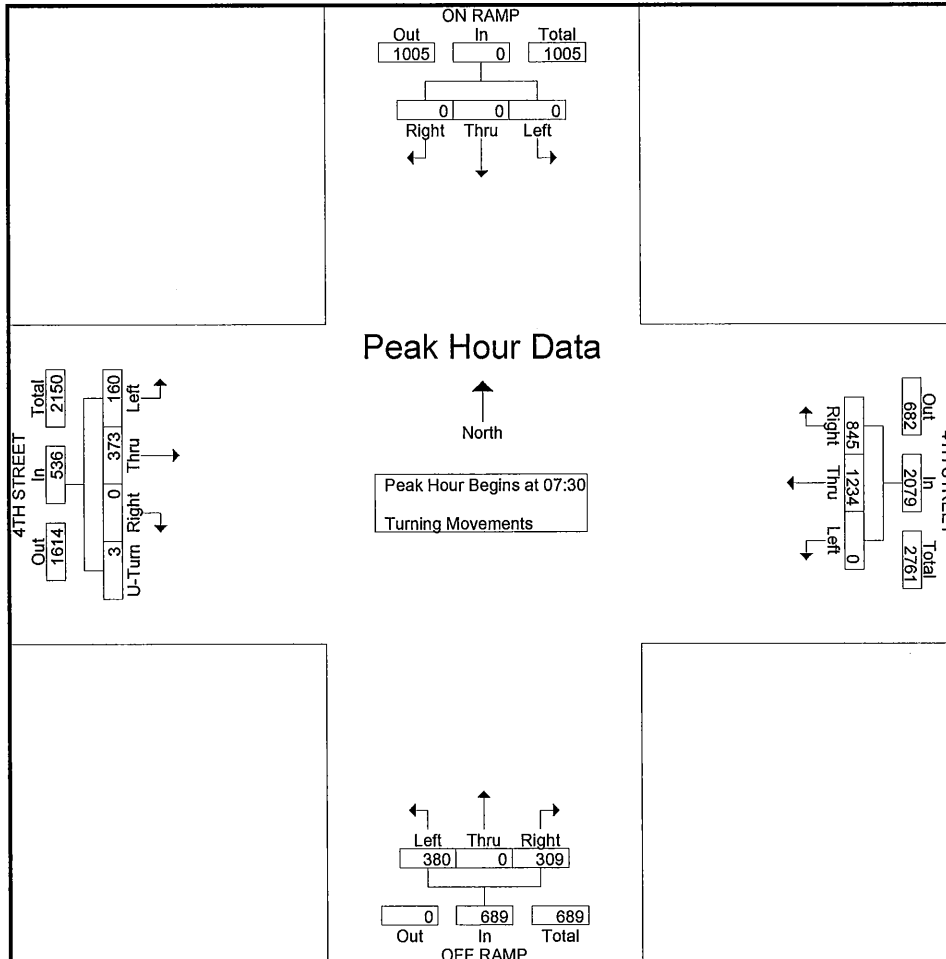

City: SANTA ANA
 N-S Direction: SR-55 NB RAMPS
 E-W Direction: 4TH STREET

File Name : H1610033
 Site Code : 0000000
 Start Date : 10/4/2016
 Page No : 3

Start Time	ON RAMP Southbound				4TH STREET Westbound				OFF RAMP Northbound				4TH STREET Eastbound					Int. Total
	Right	Thru	Left	App. Total	Right	Thru	Left	App. Total	Right	Thru	Left	App. Total	Right	Thru	Left	U-Turn	App. Total	
16:30	0	0	0	0	189	312	0	511	50	0	87	117	0	238	78	2	318	946
16:45	0	0	0	0	182	289	0	461	62	0	73	125	0	261	69	6	324	974
17:00	0	0	0	0	216	295	0	511	75	0	64	139	0	249	69	6	324	974
17:15	0	0	0	0	186	285	0	471	74	0	78	152	0	251	85	2	338	961
Total Volume	0	0	0	0	783	1161	0	1944	251	0	282	533	0	989	304	11	1304	3781
% App. Total	0	0	0	0	40.3	59.7	0	47.1	47.1	0	52.9	0	0	75.8	23.3	0.8		
PHF	.000	.000	.000	.000	.906	.930	.000	.951	.837	.000	.904	.877	.000	.985	.894	.458	.964	.970

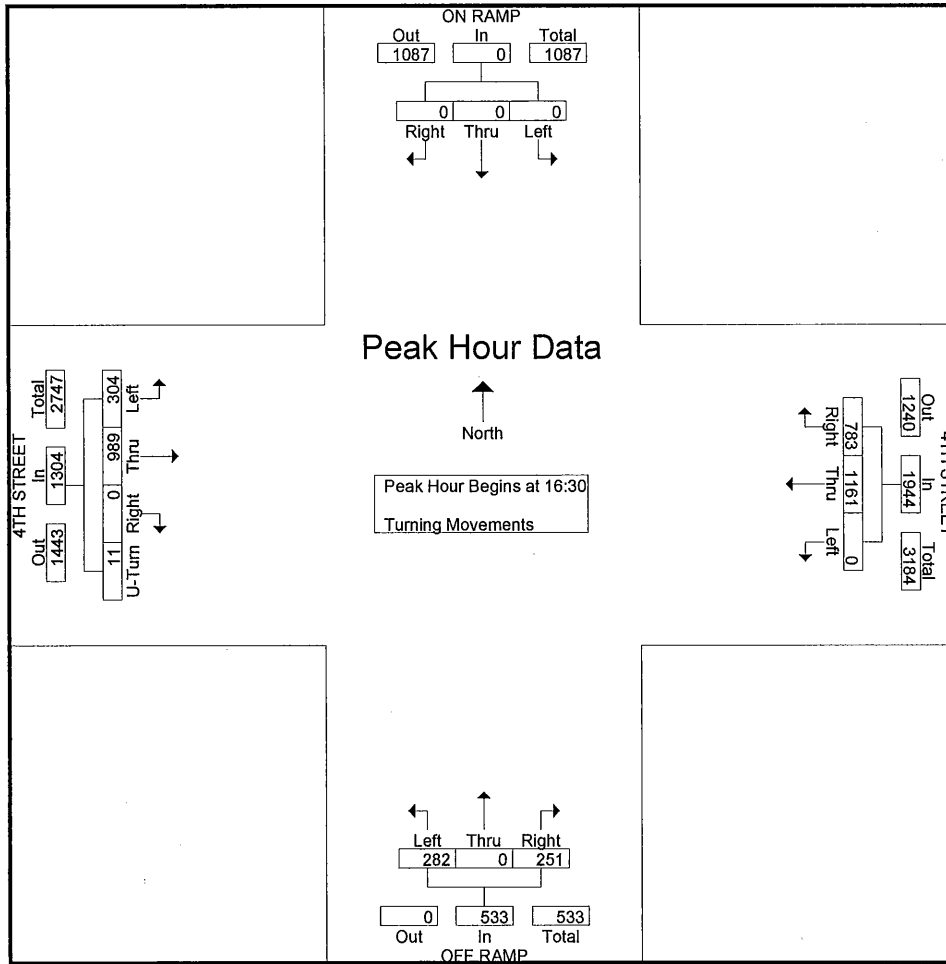

City: SANTA ANA
 N-S Direction: TUSTIN AVENUE
 E-W Direction: 6TH STREET

File Name : H1610034
 Site Code : 00000000
 Start Date : 10/4/2016
 Page No : 1

Groups Printed- Turning Movements

Start Time	TUSTIN AVENUE Southbound			DRIVEWAY Westbound			TUSTIN AVENUE Northbound			6TH STREET Eastbound			Int. Total
	Right	Thru	Left	Right	Thru	Left	Right	Thru	Left	Right	Thru	Left	
07:00	8	406	0	8	0	9	0	108	1	4	0	1	545
07:15	11	501	0	16	0	8	0	94	0	14	0	0	644
07:30	13	476	0	12	0	10	0	107	0	3	0	0	621
07:45	10	444	0	11	0	6	0	194	2	4	0	0	671
Total	42	1827	0	47	0	33	0	503	3	25	0	1	2481
08:00	18	452	0	12	0	10	0	190	0	2	0	1	685
08:15	14	437	0	7	0	4	0	233	2	5	0	0	702
08:30	20	421	0	3	0	4	0	184	5	4	0	1	642
08:45	22	333	0	4	0	7	0	201	4	8	0	4	583
Total	74	1643	0	26	0	25	0	808	11	19	0	6	2612
*** BREAK ***													
16:00	2	174	1	4	0	2	0	269	6	20	0	12	490
16:15	1	172	0	8	0	3	0	283	3	14	0	8	492
16:30	1	203	0	0	0	0	0	303	6	25	0	5	543
16:45	2	189	0	4	0	3	0	309	3	22	0	8	540
Total	6	738	1	16	0	8	0	1164	18	81	0	33	2065
17:00	0	245	0	2	0	2	0	373	8	35	0	16	681
17:15	2	228	0	3	0	0	0	295	8	17	0	9	562
17:30	2	261	0	6	0	5	0	341	3	27	0	13	658
17:45	3	186	0	2	0	2	0	381	11	18	0	7	610
Total	7	920	0	13	0	9	0	1390	30	97	0	45	2511
Grand Total	129	5128	1	102	0	75	0	3865	62	222	0	85	9669
Apprch %	2.5	97.5	0	57.6	0	42.4	0	98.4	1.6	72.3	0	27.7	
Total %	1.3	53	0	1.1	0	0.8	0	40	0.6	2.3	0	0.9	

City: SANTA ANA
 N-S Direction: TUSTIN AVENUE
 E-W Direction: 6TH STREET

File Name : H1610034
 Site Code : 00000000
 Start Date : 10/4/2016
 Page No : 2

Start Time	TUSTIN AVENUE Southbound				DRIVEWAY Westbound				TUSTIN AVENUE Northbound				6TH STREET Eastbound				Int. Total
	Right	Thru	Left	App. Total	Right	Thru	Left	App. Total	Right	Thru	Left	App. Total	Right	Thru	Left	App. Total	
Peak Hour Analysis From 07:00 to 08:45 - Peak 1 of 1																	
Peak Hour for Entire Intersection Begins at 07:45																	
07:45	10	444	0	454	11	0	6	17	0	194	2	196	4	0	0	4	671
08:00	18	452	0	470	12	0	10	22	0	190	0	190	2	0	1	3	685
08:15	14	437	0	451	7	0	4	11	0	233	2	235	5	0	0	5	702
08:30	20	421	0	441	3	0	4	7	0	184	5	189	4	0	1	5	642
Total Volume	62	1754	0	1816	33	0	24	57	0	801	9	810	15	0	2	17	2700
% App. Total	3.4	96.6	0		57.9	0	42.1		0	98.9	1.1		88.2	0	11.8		
PHF	.775	.970	.000	.966	.688	.000	.600	.648	.000	.859	.450	.862	.750	.000	.500	.850	.962

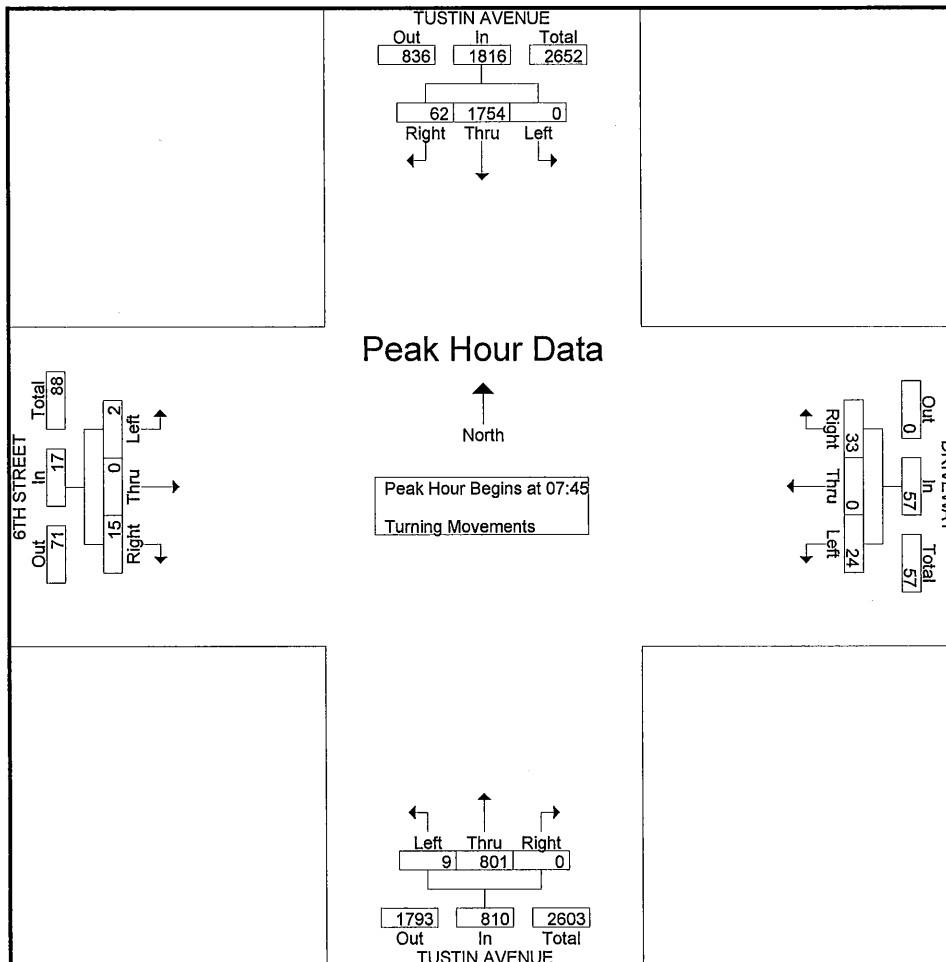

City: SANTA ANA
 N-S Direction: TUSTIN AVENUE
 E-W Direction: 6TH STREET

File Name : H1610034
 Site Code : 0000000
 Start Date : 10/4/2016
 Page No : 3

Start Time	TUSTIN AVENUE Southbound				DRIVEWAY Westbound				TUSTIN AVENUE Northbound				6TH STREET Eastbound				Int. Total
	Right	Thru	Left	App. Total	Right	Thru	Left	App. Total	Right	Thru	Left	App. Total	Right	Thru	Left	App. Total	
Peak Hour Analysis From 16:00 to 17:45 - Peak 1 of 1																	
Peak Hour for Entire Intersection Begins at 17:00																	
17:00	0	245	0	245	2	0	2	4	0	373	8	381	35	0	16	51	681
17:15	2	228	0	230	3	0	0	3	0	295	8	303	17	0	9	26	562
17:30	2	261	0	263	6	0	5	11	0	341	3	344	27	0	13	40	658
17:45	3	186	0	189	2	0	2	4	0	381	11	392	18	0	7	25	610
Total Volume	7	920	0	927	13	0	9	22	0	1390	30	1420	97	0	45	142	2511
% App. Total	0.8	99.2	0		59.1	0	40.9		0	97.9	2.1		68.3	0	31.7		
PHF	.583	.881	.000	.881	.542	.000	.450	.500	.000	.912	.682	.906	.693	.000	.703	.696	.922

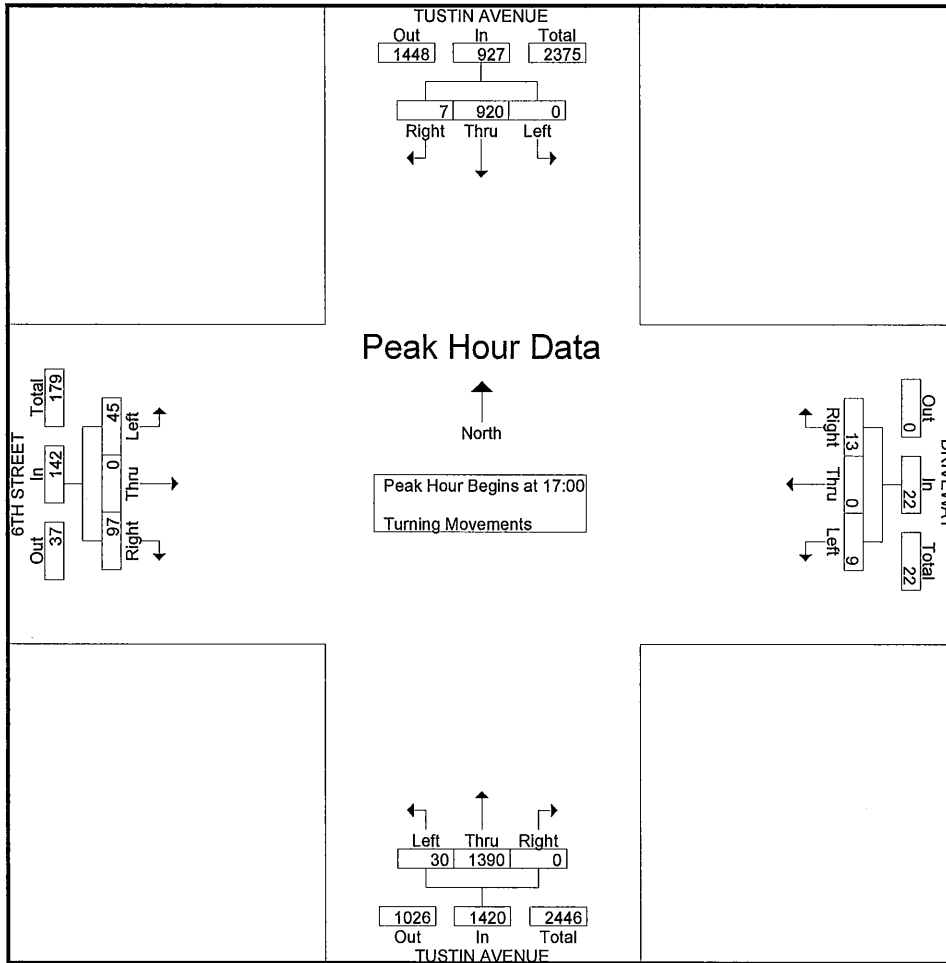

APPENDIX B-II

**EXISTING ROADWAY SEGMENT TRAFFIC
COUNT DATA**

Transportation Studies, Inc.

2640 Walnut Avenue, Suite L
Tustin, CA. 92780

Location : 1ST STREET
Segment : I-5 SB ON RAMP TO CABRILLO PAR
Client : LL&G

Site: SANTA ANA
Date: 10/04/16

Interval	EB				WB				Combined				Day:	Tuesday	
	Begin	AM	PM		AM	PM			AM	PM					
12:00	25	77	212	868	26	78	206	710	51	155	418	1,578			
12:15	16		220		14		186		30		406				
12:30	20		212		22		170		42		382				
12:45	16		224		16		148		32		372				
01:00	17	45	233	1,006	13	39	184	735	30	84	417	1,741			
01:15	10		264		8		188		18		452				
01:30	8		256		14		183		22		439				
01:45	10		253		4		180		14		433				
02:00	12	38	234	1,046	7	28	160	759	19	66	394	1,805			
02:15	10		242		8		180		18		422				
02:30	5		285		7		191		12		476				
02:45	11		285		6		228		17		513				
03:00	16	58	284	1,260	7	23	209	869	23	81	493	2,129			
03:15	17		274		4		216		21		490				
03:30	11		350		7		218		18		568				
03:45	14		352		5		226		19		578				
04:00	22	144	346	1,392	4	80	241	986	26	224	587	2,378			
04:15	40		332		10		253		50		585				
04:30	42		374		36		242		78		616				
04:45	40		340		30		250		70		590				
05:00	48	301	386	1,441	26	160	334	1,178	74	461	720	2,619			
05:15	68		352		31		312		99		664				
05:30	90		354		42		274		132		628				
05:45	95		349		61		258		156		607				
06:00	91	543	341	1,196	54	411	203	717	145	954	544	1,913			
06:15	132		312		70		176		202		488				
06:30	142		310		122		167		264		477				
06:45	178		233		165		171		343		404				
07:00	172	735	227	680	158	1,005	150	560	330	1,740	377	1,240			
07:15	194		184		229		160		423		344				
07:30	179		123		276		128		455		251				
07:45	190		146		342		122		532		268				
08:00	234	917	154	505	279	919	94	323	513	1,836	248	828			
08:15	196		120		246		72		442		192				
08:30	239		142		200		87		439		229				
08:45	248		89		194		70		442		159				
09:00	182	824	86	312	148	586	72	288	330	1,410	158	600			
09:15	186		84		150		62		336		146				
09:30	226		72		130		84		356		156				
09:45	230		70		158		70		388		140				
10:00	202	774	72	242	174	630	92	238	376	1,404	164	480			
10:15	210		54		134		58		344		112				
10:30	176		68		158		48		334		116				
10:45	186		48		164		40		350		88				
11:00	214	895	48	150	176	689	46	123	390	1,584	94	273			
11:15	216		34		172		30		388		64				
11:30	219		45		176		32		395		77				
11:45	246		23		165		15		411		38				
Totals	5,351		10,098		4,648		7,486		9,999		17,584				
Split%	53.5		57.4		46.5		42.6								
Day Totals		15,449				12,134				27,583					
Day Splits		56.0				44.0									
Peak Hour	08:00		04:30		07:30		05:00		07:30		05:00				
Volume	917		1,452		1,143		1,178		1,942		2,619				
Factor	0.92		0.94		0.84		0.88		0.91		0.91				

Transportation Studies, Inc.

2640 Walnut Avenue, Suite L
Tustin, CA. 92780

Location : 1ST STREET
Segment : CABRILLO PARK & GOLDEN CIRCLE
Client : LL&G

Site: SANTA ANA
Date: 10/04/16

Interval	EB			WB			Combined		Day:	Tuesday		
	Begin	AM	PM	AM	PM	AM	PM					
12:00	12	44	164	692	24	60	158	605	36	104	322	1,297
12:15	9		171		13		152		22		323	
12:30	12		178		15		139		27		317	
12:45	11		179		8		156		19		335	
01:00	14	35	178	698	16	39	150	611	30	74	328	1,309
01:15	7		194		7		176		14		370	
01:30	7		160		11		142		18		302	
01:45	7		166		5		143		12		309	
02:00	9	25	177	699	4	19	129	597	13	44	306	1,296
02:15	8		162		7		152		15		314	
02:30	2		178		4		152		6		330	
02:45	6		182		4		164		10		346	
03:00	11	44	181	769	5	18	160	675	16	62	341	1,444
03:15	11		181		5		175		16		356	
03:30	13		205		6		166		19		371	
03:45	9		202		2		174		11		376	
04:00	14	89	246	946	8	57	174	749	22	146	420	1,695
04:15	24		228		9		207		33		435	
04:30	24		238		18		176		42		414	
04:45	27		234		22		192		49		426	
05:00	32	200	244	960	15	122	243	835	47	322	487	1,795
05:15	45		246		30		206		75		452	
05:30	60		234		33		192		93		426	
05:45	63		236		44		194		107		430	
06:00	62	396	238	822	40	311	174	606	102	707	412	1,428
06:15	95		220		54		156		149		376	
06:30	109		194		86		140		195		334	
06:45	130		170		131		136		261		306	
07:00	119	492	156	455	126	792	126	448	245	1,284	282	903
07:15	124		107		165		126		289		233	
07:30	123		86		228		94		351		180	
07:45	126		106		273		102		399		208	
08:00	155	677	113	378	212	798	76	263	367	1,475	189	641
08:15	152		98		216		65		368		163	
08:30	183		101		192		66		375		167	
08:45	187		66		178		56		365		122	
09:00	137	585	59	208	108	455	66	275	245	1,040	125	483
09:15	142		58		113		59		255		117	
09:30	142		47		102		80		244		127	
09:45	164		44		132		70		296		114	
10:00	155	579	45	149	136	528	91	225	291	1,107	136	374
10:15	150		31		127		52		277		83	
10:30	134		46		126		40		260		86	
10:45	140		27		139		42		279		69	
11:00	142	630	35	97	144	548	44	117	286	1,178	79	214
11:15	156		20		135		24		291		44	
11:30	142		33		142		29		284		62	
11:45	190		9		127		20		317		29	
Totals	3,796		6,873		3,747		6,006		7,543		12,879	
Split%	50.3		53.4		49.7		46.6					
Day Totals		10,669				9,753				20,422		
Day Splits		52.2				47.8						
Peak Hour	08:00		04:30		07:30		05:00		07:45		05:00	
Volume	677		962		929		835		1,509		1,795	
Factor	0.91		0.98		0.85		0.86		0.95		0.92	

Transportation Studies, Inc.

2640 Walnut Avenue, Suite L

Tustin, CA. 92780

Location : 1ST STEET
 Segment : GOLDEN CIRCLE DR TO TUSTIN AVE
 Client : LL&G

Site: SANTA ANA
 Date: 10/04/16

Interval	EB				WB				Combined		Day:	Tuesday
	AM	PM	AM	PM	AM	PM	AM	PM				
12:00	16	51	232	980	11	52	184	752	27	103	416	1,732
12:15	14		218		16		178		30		396	
12:30	14		260		19		194		33		454	
12:45	7		270		6		196		13		466	
01:00	18	41	289	987	12	36	188	667	30	77	477	1,654
01:15	6		248		8		155		14		403	
01:30	11		244		12		168		23		412	
01:45	6		206		4		156		10		362	
02:00	8	25	268	1,041	4	23	153	689	12	48	421	1,730
02:15	7		230		10		154		17		384	
02:30	2		246		1		186		3		432	
02:45	8		297		8		196		16		493	
03:00	9	40	276	1,183	4	19	205	770	13	59	481	1,953
03:15	14		257		4		182		18		439	
03:30	8		326		7		190		15		516	
03:45	9		324		4		193		13		517	
04:00	16	112	389	1,443	11	63	204	802	27	175	593	2,245
04:15	37		314		14		201		51		515	
04:30	27		370		14		191		41		561	
04:45	32		370		24		206		56		576	
05:00	46	239	440	1,572	26	112	280	929	72	351	720	2,501
05:15	56		400		26		224		82		624	
05:30	63		344		30		219		93		563	
05:45	74		388		30		206		104		594	
06:00	80	473	338	1,207	38	316	194	699	118	789	532	1,906
06:15	120		297		54		182		174		479	
06:30	134		300		96		155		230		455	
06:45	139		272		128		168		267		440	
07:00	171	665	218	621	142	961	118	463	313	1,626	336	1,084
07:15	171		130		195		138		366		268	
07:30	142		134		279		96		421		230	
07:45	181		139		345		111		526		250	
08:00	208	858	149	488	250	927	98	326	458	1,785	247	814
08:15	210		104		257		92		467		196	
08:30	224		134		218		76		442		210	
08:45	216		101		202		60		418		161	
09:00	186	715	74	299	158	588	54	227	344	1,303	128	526
09:15	156		83		134		46		290		129	
09:30	180		76		120		60		300		136	
09:45	193		66		176		67		369		133	
10:00	209	703	78	216	164	549	68	177	373	1,252	146	393
10:15	186		44		132		48		318		92	
10:30	142		66		135		27		277		93	
10:45	166		28		118		34		284		62	
11:00	197	935	52	130	151	601	46	116	348	1,536	98	246
11:15	220		26		143		22		363		48	
11:30	253		40		158		29		411		69	
11:45	265		12		149		19		414		31	
Totals	4,857		10,167		4,247		6,617		9,104		16,784	
Split%	53.4		60.6		46.6		39.4					
Day Totals		15,024				10,864				25,888		
Day Splits		58.0				42.0						
Peak Hour	11:00		04:30		07:30		04:45		07:45		05:00	
Volume	935		1,580		1,131		929		1,893		2,501	
Factor	0.88		0.90		0.82		0.83		0.90		0.87	

Transportation Studies, Inc.

2640 Walnut Avenue, Suite L
Tustin, CA. 92780

Location : CABRILLO PARK DRIVE
Segment : XEROX CENTRE TO STATE FUND
Client : LL&G

Site: SANTA ANA
Date: 10/04/16

Interval	NB				SB				Combined				Day:	Tuesday
	Begin	AM	PM		AM	PM			AM	PM				
12:00	17	42	104	416	4	20	74	314	21	62	178	730		
12:15	9		111		5		92		14		203			
12:30	12		95		5		70		17		165			
12:45	4		106		6		78		10		184			
01:00	7	18	110	415	3	9	68	314	10	27	178	729		
01:15	4		112		2		88		6		200			
01:30	3		93		4		66		7		159			
01:45	4		100		0		92		4		192			
02:00	3	18	100	433	2	9	68	294	5	27	168	727		
02:15	2		98		2		64		4		162			
02:30	6		123		4		72		10		195			
02:45	7		112		1		90		8		202			
03:00	2	12	110	522	3	9	62	248	5	21	172	770		
03:15	6		136		1		66		7		202			
03:30	1		130		2		58		3		188			
03:45	3		146		3		62		6		208			
04:00	10	58	160	671	3	38	70	286	13	96	230	957		
04:15	14		146		9		76		23		222			
04:30	19		216		13		62		32		278			
04:45	15		149		13		78		28		227			
05:00	15	114	224	805	21	90	100	335	36	204	324	1,140		
05:15	26		204		13		90		39		294			
05:30	40		207		27		73		67		280			
05:45	33		170		29		72		62		242			
06:00	29	159	158	537	29	201	60	202	58	360	218	739		
06:15	36		154		38		50		74		204			
06:30	50		122		47		41		97		163			
06:45	44		103		87		51		131		154			
07:00	56	299	94	313	71	509	40	172	127	808	134	485		
07:15	80		97		140		37		220		134			
07:30	80		58		132		52		212		110			
07:45	83		64		166		43		249		107			
08:00	78	305	70	213	160	551	30	114	238	856	100	327		
08:15	72		46		129		24		201		70			
08:30	74		52		146		28		220		80			
08:45	81		45		116		32		197		77			
09:00	56	271	46	180	88	319	16	76	144	590	62	256		
09:15	71		40		102		23		173		63			
09:30	74		48		65		23		139		71			
09:45	70		46		64		14		134		60			
10:00	60	261	48	135	68	240	24	57	128	501	72	192		
10:15	78		30		48		12		126		42			
10:30	62		30		66		14		128		44			
10:45	61		27		58		7		119		34			
11:00	94	372	26	85	64	288	15	29	158	660	41	114		
11:15	93		21		64		9		157		30			
11:30	101		16		76		4		177		20			
11:45	84		22		84		1		168		23			
Totals	1,929		4,725		2,283		2,441		4,212		7,166			
Split%	45.8		65.9		54.2		34.1							
Day Totals		6,654				4,724				11,378				
Day Splits		58.5				41.5								
Peak Hour	11:00		05:00		07:45		04:45		07:15		05:00			
Volume	372		805		601		341		919		1,140			
Factor	0.92		0.90		0.91		0.85		0.92		0.88			

Transportation Studies, Inc.

2640 Walnut Avenue, Suite L
Tustin, CA. 92780

Location : 4TH STREET
Segment : I-5 NB RAMP TO CABRILLO PARK D
Client : LL&G

Site: SANTA ANA
Date: 10/04/16

Interval	EB				WB				Combined		Day:	Tuesday
	AM		PM		AM		PM		AM	PM		
12:00	17	58	193	738	23	111	210	854	40	169	403	1,592
12:15	13		190		37		214		50		404	
12:30	12		182		28		212		40		394	
12:45	16		173		23		218		39		391	
01:00	11	27	201	748	9	34	203	757	20	61	404	1,505
01:15	4		179		8		178		12		357	
01:30	6		180		9		182		15		362	
01:45	6		188		8		194		14		382	
02:00	10	31	190	755	10	54	187	832	20	85	377	1,587
02:15	8		194		11		188		19		382	
02:30	7		194		8		215		15		409	
02:45	6		177		25		242		31		419	
03:00	4	27	155	697	8	58	309	1,172	12	85	464	1,869
03:15	4		184		14		281		18		465	
03:30	12		186		10		266		22		452	
03:45	7		172		26		316		33		488	
04:00	8	86	180	771	16	104	368	1,355	24	190	548	2,126
04:15	18		186		28		330		46		516	
04:30	26		206		17		328		43		534	
04:45	34		199		43		329		77		528	
05:00	24	196	229	792	38	202	398	1,348	62	398	627	2,140
05:15	40		222		46		330		86		552	
05:30	59		182		60		318		119		500	
05:45	73		159		58		302		131		461	
06:00	70	388	144	553	46	277	268	932	116	665	412	1,485
06:15	71		148		54		219		125		367	
06:30	123		135		89		217		212		352	
06:45	124		126		88		228		212		354	
07:00	142	814	114	350	112	662	170	566	254	1,476	284	916
07:15	212		82		136		130		348		212	
07:30	218		78		190		144		408		222	
07:45	242		76		224		122		466		198	
08:00	232	896	90	283	200	735	96	330	432	1,631	186	613
08:15	246		53		200		86		446		139	
08:30	208		58		197		86		405		144	
08:45	210		82		138		62		348		144	
09:00	186	702	92	258	151	615	70	267	337	1,317	162	525
09:15	156		64		136		70		292		134	
09:30	166		60		167		60		333		120	
09:45	194		42		161		67		355		109	
10:00	180	733	47	144	176	709	64	191	356	1,442	111	335
10:15	185		31		176		45		361		76	
10:30	192		30		165		44		357		74	
10:45	176		36		192		38		368		74	
11:00	179	757	30	90	180	732	38	134	359	1,489	68	224
11:15	192		20		186		37		378		57	
11:30	202		20		178		34		380		54	
11:45	184		20		188		25		372		45	
Totals	4,715		6,179		4,293		8,738		9,008		14,917	
Split%	52.3		41.4		47.7		58.6					
Day Totals		10,894				13,031				23,925		
Day Splits		45.5				54.5						
Peak Hour	07:30		04:30		07:45		04:15		07:30		04:30	
Volume	938		856		821		1,385		1,752		2,241	
Factor	0.95		0.93		0.92		0.87		0.94		0.89	

Transportation Studies, Inc.

2640 Walnut Avenue, Suite L
Tustin, CA. 92780

Location : 4TH STREET
Segment : CABRILLO PARK DR TO GOLDEN CIR
Client : LL&G

Site: SANTA ANA
Date: 10/04/16

Interval	EB				WB				Combined		Day:	Tuesday
	AM	PM	AM	PM	AM	PM	AM	PM				
12:00	22	82	220	805	30	114	205	835	52	196	425	1,640
12:15	30		199		35		214		65		413	
12:30	12		190		26		204		38		394	
12:45	18		196		23		212		41		408	
01:00	10	27	201	818	10	42	210	786	20	69	411	1,604
01:15	6		198		12		202		18		400	
01:30	6		200		12		190		18		390	
01:45	5		219		8		184		13		403	
02:00	14	38	211	837	9	47	195	876	23	85	406	1,713
02:15	7		222		8		219		15		441	
02:30	8		202		10		218		18		420	
02:45	9		202		20		244		29		446	
03:00	8	28	179	703	8	55	310	1,170	16	83	489	1,873
03:15	3		178		17		275		20		453	
03:30	10		174		10		277		20		451	
03:45	7		172		20		308		27		480	
04:00	8	77	180	758	21	125	392	1,405	29	202	572	2,163
04:15	14		199		31		326		45		525	
04:30	25		185		35		352		60		537	
04:45	30		194		38		335		68		529	
05:00	30	206	240	824	45	288	418	1,467	75	494	658	2,291
05:15	40		218		58		398		98		616	
05:30	65		188		101		327		166		515	
05:45	71		178		84		324		155		502	
06:00	76	461	152	658	73	362	302	987	149	823	454	1,645
06:15	83		172		71		237		154		409	
06:30	136		162		106		224		242		386	
06:45	166		172		112		224		278		396	
07:00	156	978	158	509	145	791	202	693	301	1,769	360	1,202
07:15	235		109		182		171		417		280	
07:30	246		120		204		168		450		288	
07:45	341		122		260		152		601		274	
08:00	290	1,082	107	380	221	774	138	472	511	1,856	245	852
08:15	293		76		180		114		473		190	
08:30	260		92		197		122		457		214	
08:45	239		105		176		98		415		203	
09:00	184	745	113	344	136	616	100	373	320	1,361	213	717
09:15	164		91		154		81		318		172	
09:30	180		67		170		92		350		159	
09:45	217		73		156		100		373		173	
10:00	207	805	68	208	155	669	86	257	362	1,474	154	465
10:15	208		51		172		59		380		110	
10:30	194		46		159		60		353		106	
10:45	196		43		183		52		379		95	
11:00	189	805	43	137	182	794	47	165	371	1,599	90	302
11:15	185		41		207		42		392		83	
11:30	190		30		203		40		393		70	
11:45	241		23		202		36		443		59	
Totals	5,334		6,981		4,677		9,486		10,011		16,467	
Split%	53.3		42.4		46.7		57.6					
Day Totals		12,315				14,163				26,478		
Day Splits		46.5				53.5						
Peak Hour	07:45		01:45		07:15		04:30		07:45		04:30	
Volume	1,184		854		867		1,503		2,042		2,340	
Factor	0.87		0.96		0.83		0.90		0.85		0.89	

Transportation Studies, Inc.

2640 Walnut Avenue, Suite L

Tustin, CA. 92780

Location : TUSTIN AVENUE
 Segment : 1ST ST TO 4TH ST
 Client : LL&G

Site: SANTA ANA
 Date: 10/04/16

Interval	NB				SB				Combined		Day:	Tuesday
	AM		PM		AM		PM		AM	PM		
12:00	15	47	120	559	9	32	114	462	24	79	234	1,021
12:15	12		134		10		103		22		237	
12:30	10		152		7		113		17		265	
12:45	10		153		6		132		16		285	
01:00	5	19	152	599	5	15	116	458	10	34	268	1,057
01:15	5		136		5		126		10		262	
01:30	5		154		4		108		9		262	
01:45	4		157		1		108		5		265	
02:00	5	16	145	608	5	14	116	469	10	30	261	1,077
02:15	5		138		5		110		10		248	
02:30	2		142		1		118		3		260	
02:45	4		183		3		125		7		308	
03:00	4	29	172	716	4	16	130	505	8	45	302	1,221
03:15	10		164		2		124		12		288	
03:30	7		190		2		117		9		307	
03:45	8		190		8		134		16		324	
04:00	6	73	212	909	3	37	122	476	9	110	334	1,385
04:15	19		206		4		116		23		322	
04:30	23		253		12		118		35		371	
04:45	25		238		18		120		43		358	
05:00	26	168	277	1,053	18	111	134	559	44	279	411	1,612
05:15	46		222		30		144		76		366	
05:30	51		270		26		155		77		425	
05:45	45		284		37		126		82		410	
06:00	35	251	238	793	36	355	106	413	71	606	344	1,206
06:15	64		179		62		102		126		281	
06:30	72		198		105		109		177		307	
06:45	80		178		152		96		232		274	
07:00	91	414	158	423	163	883	88	294	254	1,297	246	717
07:15	64		89		212		68		276		157	
07:30	117		102		248		55		365		157	
07:45	142		74		260		83		402		157	
08:00	142	494	90	330	217	853	61	214	359	1,347	151	544
08:15	135		86		244		70		379		156	
08:30	101		84		204		51		305		135	
08:45	116		70		188		32		304		102	
09:00	111	390	66	234	129	475	43	152	240	865	109	386
09:15	88		60		116		35		204		95	
09:30	97		50		102		38		199		88	
09:45	94		58		128		36		222		94	
10:00	94	393	41	142	118	408	46	130	212	801	87	272
10:15	102		36		98		40		200		76	
10:30	107		41		97		21		204		62	
10:45	90		24		95		23		185		47	
11:00	126	496	30	86	104	489	29	82	230	985	59	168
11:15	125		21		118		22		243		43	
11:30	107		20		132		17		239		37	
11:45	138		15		135		14		273		29	
Totals	2,790		6,452		3,688		4,214		6,478		10,666	
Split%	43.1		60.5		56.9		39.5					
Day Totals		9,242				7,902				17,144		
Day Splits		53.9				46.1						
Peak Hour	07:30		05:00		07:30		05:00		07:30		05:00	
Volume	536		1,053		969		559		1,505		1,612	
Factor	0.94		0.93		0.93		0.90		0.94		0.95	

Transportation Studies, Inc.

2640 Walnut Avenue, Suite L

Tustin, CA. 92780

Location : TUSTIN AVENUE
 Segment : 4TH ST TO 6TH ST
 Client : LL&G

Site: SANTA ANA
 Date: 10/04/16

Interval	NB				SB				Combined		Day:	Tuesday
	AM		PM		AM		PM		AM	PM		
12:00	10	41	204	801	14	45	191	792	24	86	395	1,593
12:15	10		194		11		205		21		399	
12:30	10		204		10		178		20		382	
12:45	11		199		10		218		21		417	
01:00	3	22	198	782	5	22	184	744	8	44	382	1,526
01:15	8		200		10		196		18		396	
01:30	7		196		5		190		12		386	
01:45	4		188		2		174		6		362	
02:00	8	17	199	856	5	19	190	734	13	36	389	1,590
02:15	4		204		4		194		8		398	
02:30	2		209		3		182		5		391	
02:45	3		244		7		168		10		412	
03:00	4	19	256	1,035	8	24	195	819	12	43	451	1,854
03:15	6		239		3		236		9		475	
03:30	4		252		3		178		7		430	
03:45	5		288		10		210		15		498	
04:00	2	50	287	1,203	6	63	189	813	8	113	476	2,016
04:15	8		284		13		184		21		468	
04:30	18		314		20		222		38		536	
04:45	22		318		24		218		46		536	
05:00	19	128	357	1,410	14	176	244	962	33	304	601	2,372
05:15	22		328		38		233		60		561	
05:30	35		346		61		270		96		616	
05:45	52		379		63		215		115		594	
06:00	35	307	330	1,094	72	758	198	664	107	1,065	528	1,758
06:15	60		254		142		168		202		422	
06:30	78		254		263		146		341		400	
06:45	134		256		281		152		415		408	
07:00	140	604	175	543	301	1,444	134	458	441	2,048	309	1,001
07:15	124		138		349		106		473		244	
07:30	130		124		412		104		542		228	
07:45	210		106		382		114		592		220	
08:00	219	885	91	325	361	1,380	78	309	580	2,265	169	634
08:15	242		82		351		89		593		171	
08:30	216		80		342		72		558		152	
08:45	208		72		326		70		534		142	
09:00	175	667	74	274	270	908	52	203	445	1,575	126	477
09:15	170		84		234		53		404		137	
09:30	152		52		216		50		368		102	
09:45	170		64		188		48		358		112	
10:00	170	653	52	171	186	632	57	167	356	1,285	109	338
10:15	185		43		124		48		309		91	
10:30	140		38		152		38		292		76	
10:45	158		38		170		24		328		62	
11:00	179	764	30	86	174	742	31	92	353	1,506	61	178
11:15	207		26		160		24		367		50	
11:30	184		16		203		24		387		40	
11:45	194		14		205		13		399		27	
Totals	4,157		8,580		6,213		6,757		10,370		15,337	
Split%	40.1		55.9		59.9		44.1					
Day Totals		12,737				12,970				25,707		
Day Splits		49.5				50.5						
Peak Hour	07:45		05:00		07:30		04:45		07:45		05:00	
Volume	887		1,410		1,506		965		2,323		2,372	
Factor	0.92		0.93		0.91		0.89		0.98		0.96	