



## ▼ 4000 Trim Strike

A simple strike plate that can be surface mounted on a wood or metal jamb or mortised flush. Furnished with two #10 flat head machine screws and two #10 flat head wood screws.

### MATERIAL/FINISH:

Made of aluminum. Available in US28 (628) Clear Anodized. Also anodized in 313 and 335. Contact factory for other available finishes.

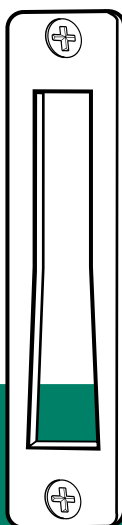

4000-012

## MS® Deadbolt Strikes

### 4000, 4001, MS4002

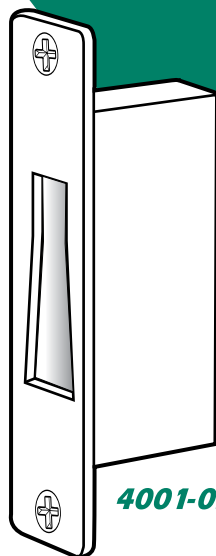

4001-032

## ▼ 4001 Box Strike

Same trim plate as 4000 but with dust box added. Customarily used only for wood construction where the dust box prevents chips, sawdust and other debris from entering strike. Also furnished with both wood and machine screws.

### MATERIAL/FINISH:

Trim plate is aluminum, box is steel plated for corrosion resistance. Available in US28 (628) Clear Anodized. Also anodized in 313 and 335. Contact factory for other available finishes.



MS4002-012

## ▼ MS4002 Armored Strike

Same trim plate as 4000 and 4001, but backed up by a massive steel doubler designed to prevent the method of forced entry known as "jamb peeling." Fits within aluminum or other hollow jamb sections with trim face flush, the steel completely hidden. Available flat or radiused, for pairs of doors\*, and to fit all MS® deadbolts including the hookbolt version in sliding doors. (Hookbolt use dictates door/jamb gap of 1/8" or less.) Unhanded, may be used with RH or LH swinging or sliding doors.

### MATERIAL/FINISH:

Trim plate is aluminum. Reinforcement doubler is steel plated for corrosion resistance. Available in US28 (628) Clear Anodized. Also anodized in 313 and 335. Contact factory for other available finishes.

\*Can be used with two-point and three-point MS® locks.

## ▼ Function

The majority of Adams Rite MS® deadbolts are installed in metal construction where the strike cutout can be simply a slot in the jamb. However, for aesthetic reasons or, in the case of the MS4002, for added security, many who specify the MS® deadbolt add one of these strikes.



# 4000 Series MS® Deadbolt Strikes

## DIMENSIONS & INSTALLATION

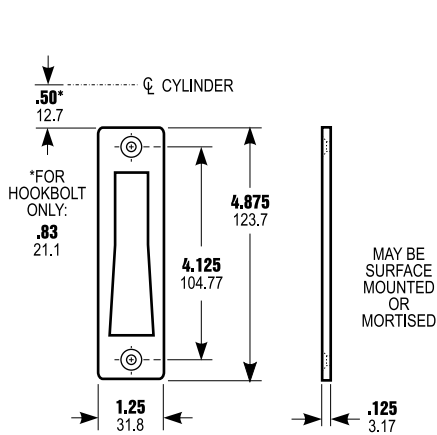

**4000 Trim Strike  
Strike Plate Only**

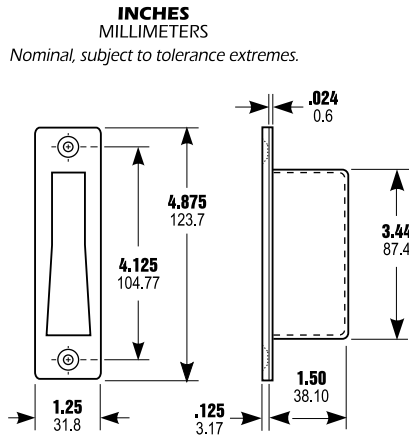

**4001 Box Strike  
Strike Plate with Dust Box**

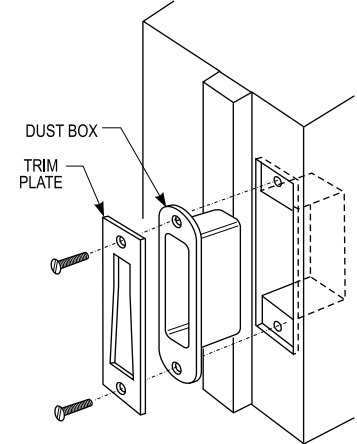

**Mortise Jamb  
Preparation**

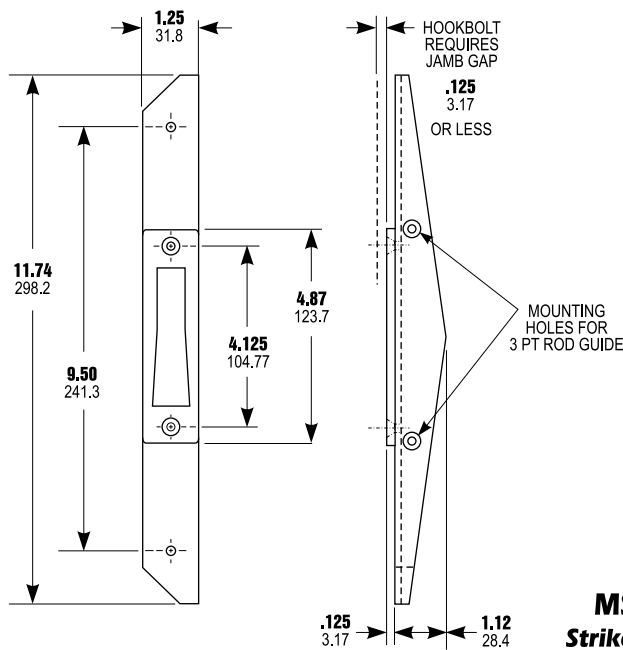

**MS4002 Armored Strike  
Strike Plate with Reinforcement**

### Hollow Channel Jamb Preparation

DRILL AND C'SK FOR  
#10 FLAT HEAD  
MACHINE SCREWS  
(2 PLACES)  
FOUR SCREWS  
FURNISHED

CUTOUT  
TOLERANCE:  
+ .015 +0.38  
- .000 -0.0

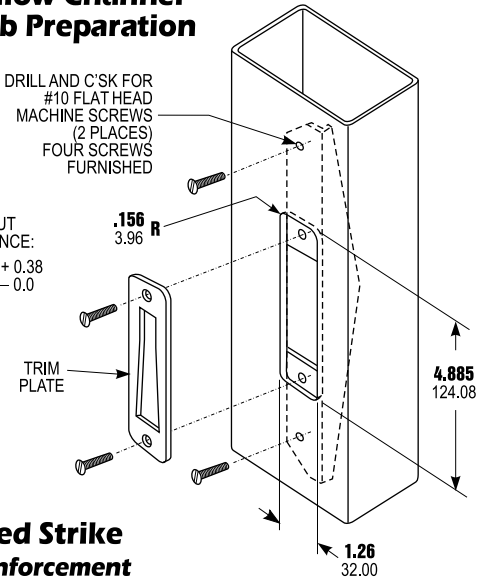

## HOW TO ORDER

Specify quantity and the following information.

Strike Model	Trim Plate Shape	Trim Plate Corners
<b>4000</b> Trim Strike	<b>0</b> Flat	<b>1</b> Square corners
<b>4001</b> Box Strike	<b>1</b> Radius	<b>2</b> Round corners
<b>MS4002</b> Armored Strike		

**4001-011-313**

Compatible Deadlock	Finish
<b>1</b> All standard MS® locks with 1-3/8" bolt throw	<b>628</b> Clear Anodized
<b>2</b> 1850A-020 with 3/4" bolt throw only	<b>313</b> Dark Bronze Anodized
<b>3</b> All MS-050 "Hookbolt" locks	<b>335</b> Black Anodized

## OPTIONS

Specify flat or radius shape of trim plate, round or square corners and lock compatibility when ordering. 4003-01 ANSI-dimensioned lipped strike also available for MS1850SN Deadbolt. (See page SW-3.)

# BURGLAR BAR PACKAGE

ALL ROOF PENETRATIONS 96 SQUARE INCHES OR LARGER ARE REQUIRED TO BE SECURED WITH BURGLAR BARS. CONTACT THE POLICE DEPARTMENT AT 647-5840 FOR SPECIFICATIONS AND ROUGH INSPECTION PRIOR TO MECHANICAL SIGNOFF

## FEATURES:

BURGLAR BAR INSERTS ARE FABRICATED OF GALVANIZED STEEL AND 1/2" STEEL ROD

INSERTS ARE A ONE-PIECE WELDED CONSTRUCTION

ALL WELDS ARE SPRAYED WITH GALVANIZING COMPOUND

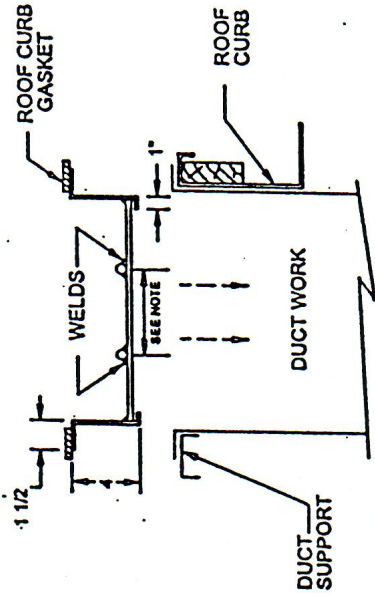
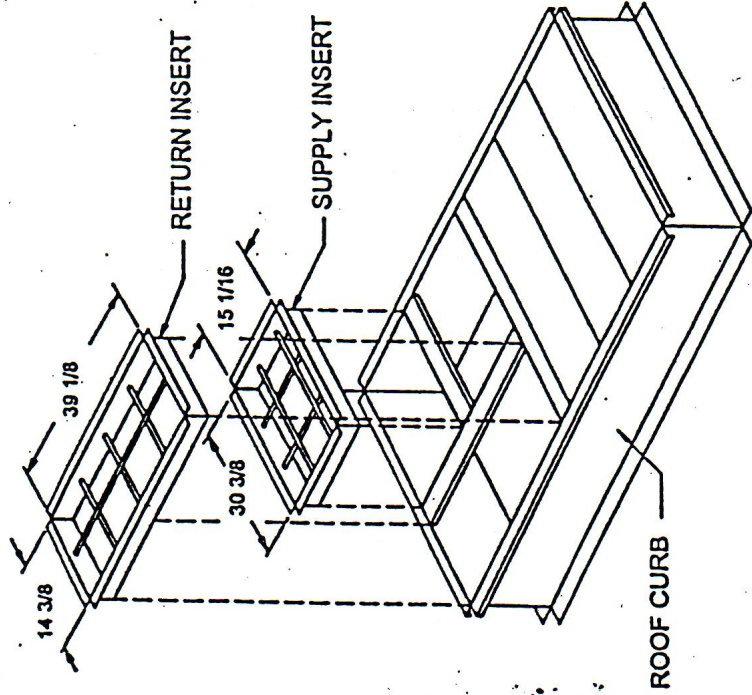

BURGLAR BAR CROSS SECTION

## NOTE:

DISTANCE BETWEEN STEEL RODS IS NOT GREATER THAN 5 INCHES.

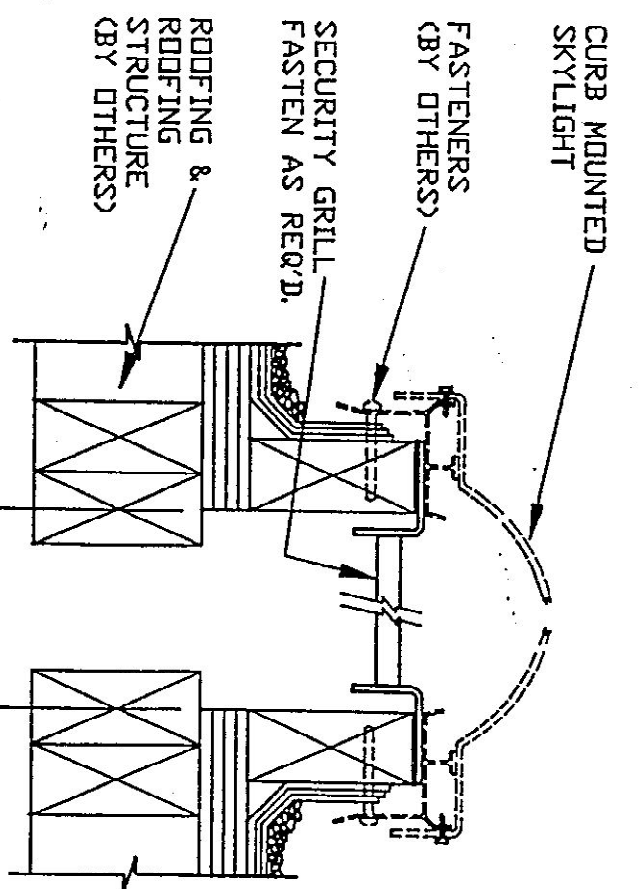
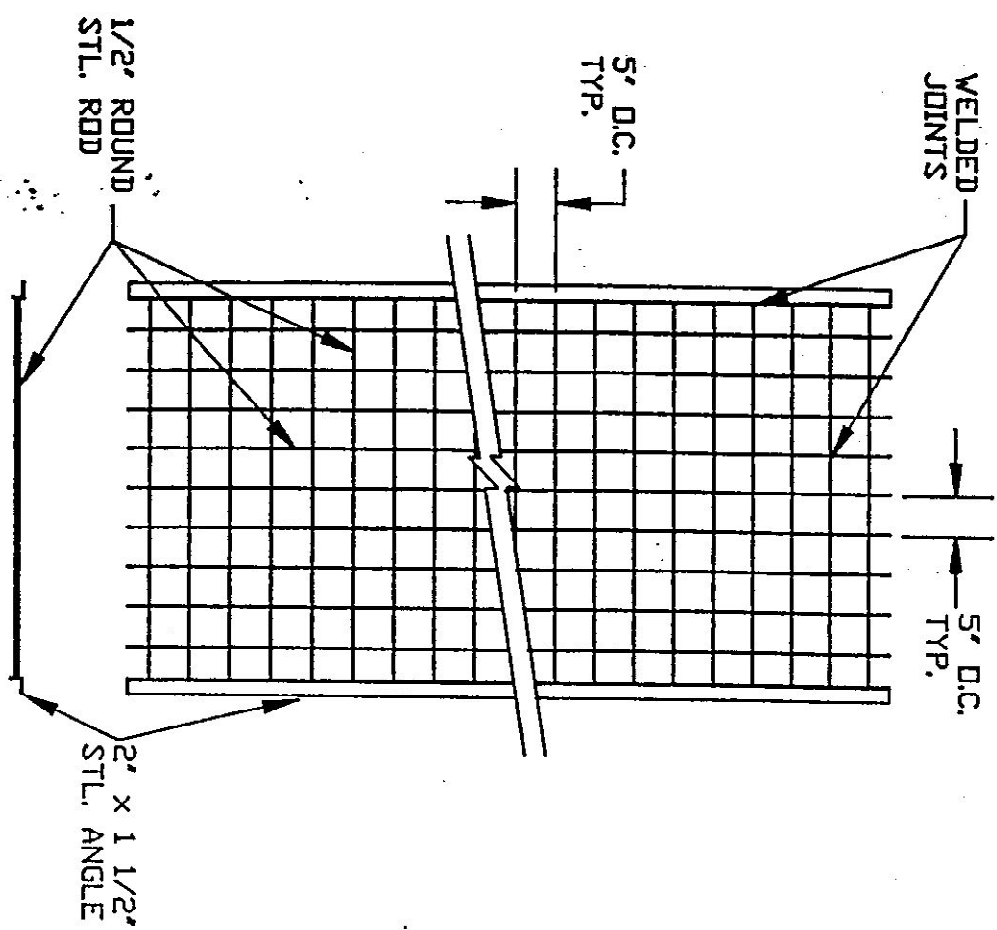

CURB MOUNTED INSTALLATION  
1/4 SCALE

### DIVISION 3. BUILDING SECURITY REGULATIONS

#### Sec. 8-200. Application and scope.

The provisions of this security ordinance shall apply to all activities for which a building permit is required.

Additions, alterations and repairs: Fifty (50) percent more of the building's current valuation. When additions, alterations or repairs within any twelve-month period exceed fifty (50) percent of the value of any existing building or structure, each building or structure shall be made to conform to the requirements for new buildings or structures.

All applicable state and local fire codes must be adhered to. No portion of this division shall supersede any local, state or federal laws, regulations or codes.

(Ord. No. NS-1424, § 1, 6-5-78; Ord. No. NS-1794, § 1, 10-14-85)

#### Sec. 8-201. Definitions of technical terms.

The following terms used in this division shall have the meanings indicated below:

Approved means certified as meeting the requirements of this division by the enforcing authority or his authorized agents, or by other officials designated by the enforcing authority to give approval on a particular matter dealt with by the provisions of this division with regard to a given material, mode of construction, piece of equipment or device.

Auxiliary locking device is a secondary locking system added to the primary locking system to provide additional security.

Bolt is a metal bar which, when actuated, is projected (or "thrown") either horizontally or vertically into a retaining member, such as a strike plate, to prevent a door from moving or opening.

Bolt projection (or bolt throw) is the distance from the edge of the door, at the bolt center line, to the farthest point on the bolt in the projected position, when subjected to end pressure.

Burglary resistant glazing means those materials as defined in Underwriters Laboratories Bulletin 972.

Commercial or industrial building is a building, or portion thereof, used for a purpose other than dwelling.

Component, as distinguished from a part, is a subassembly which combines with other components to make up a total door or window assembly. For example, the primary components of a door assembly include: Door, lock, hinges, jamb/wall, jamb/strike and wall.

Cylinder is the subassembly of a lock containing the cylinder core, tumbler mechanism and the keyway. A double cylinder lock is one which has a key-actuated cylinder on both the exterior and interior of the door.

Cylinder core or cylinder plug is the central part of a cylinder containing the keyway, which is rotated by the key to operate the lock mechanism.

Cylinder guard is a hardened metal ring or plate surrounding the otherwise exposed portion of a cylinder lock to resist cutting, drilling, prying, pulling, or wrenching with common tools.

Deadbolt is a lock bolt which does not have a spring action as opposed to a latch bolt, which does. The bolt must be actuated by a key and/or a knob or thumb turn and when projected becomes locked against return by end pressure.

Dead latch is a spring actuated latch bolt having a beveled end and incorporating a plunger which, when depressed, automatically locks the projected latch bolt against return by end pressure.

Door assembly means a unit composed of a group of parts or components which make up a closure for a passageway through a wall. For the purposes of this division, a door assembly consists of the following parts: Doors, hinges, locking device or devices; operation contracts (such as handles, knobs, push plates); miscellaneous hardware and closures; the frame, including the head, threshold, and jambs plus the anchorage devices to the surrounding wall and a portion of the surrounding wall extending thirty-six (36) inches from each side of the jambs and sixteen (16) inches above the head.

Door stops are the projections along the top and sides of a door jamb which check the door's swinging action.

Double cylinder deadbolt is a deadbolt which can be activated only by a key from either the interior or exterior of the building.

Dwelling is a building or portion thereof designated exclusively for residential occupancy, including single-family and multiple-family dwellings.

Flushbolt is a normal manual, key, turn operated or automatic releasing metal throwbolt, normally used on inactive door(s) that is attached to the top and bottom of the door and engages in the head and threshold of the frame.

Fully tempered glass means those materials meeting or exceeding ANSI Standard 297.1--Safety Glazing.

Inactive leaf or door means either leaf or door of a pair of doors which has no surface mounted hardware and which receives and holds the latch or bolt of the primary locking system.

Jamb is the vertical members of a door frame to which the door is secured.

Jamb/strike means that component of a door assembly which receives and holds secure the extended lock bolt; the strike and jamb used together are considered a unit.

Jamb/wall is that component of a door assembly to which a door is attached and secured; the wall and jamb used together are considered a unit.

Key-in-knob is a lockset having the key cylinder and other lock mechanisms contained in the knob.

Latch or latch bolt is a beveled, spring-actuated bolt, which may or may not have a deadlocking device.

Lock or lockset is a keyed device (complete with cylinder, latch or deadbolt mechanism, and trim such as knobs, levers, thumb turns, escutcheons, etc.) for securing a door in a closed position against forced entry.

Locked indicator is a device indicating whether the lock set (deadbolt, etc.) is locked or open.

Locking device is a part of a window or sliding door assembly which is intended to prevent movement of the movable sash or door.

Minimum maintained means measurable light level at furthest point from lighting source at ground level.

Multiple-family dwelling is a building or portion thereof designed for occupancy by one (1) or more persons living independently of each other, including hotels, motels, apartments, duplexes, town houses, and condominiums.

Panic hardware is a latching device on a door assembly for use when emergency egress is required due to a fire or other threat to life safety. Such devices are designed so that they will facilitate the safe egress of people in case of an emergency when a pressure not to exceed fifteen (15) pounds is applied to the releasing device in the direction of exit travel. Such releasing devices are bars or panels extending not less than two-thirds (2/3) of the width of the door and placed at heights suitable for the service required, not less than thirty (30) nor more than forty-four (44) inches above the floor.

Part, as distinguished from component, is a unit (or subassembly) which combines with other units to make up a component.

Primary locking device is the single locking system on a door or window unit whose function is to prevent unauthorized intrusion.

Private dwelling or single-family dwelling is a building designed exclusively for occupancy by one (1) family.

Rail is the horizontal members of a sash frame. A meeting rail is one which mates with a rail of another sash or framing member of the window frame when the sash is in the closed position.

Sash is an assembly of stiles, rails, and, sometimes, muntins assembled into a single frame which supports the glazing material. A fixed sash is one which is not intended to be opened. A movable sash is intended to be opened.

Sill is the lowest horizontal member of a window frame.

Single cylinder deadbolt is a deadbolt lock which is activated from the exterior by a key and from the interior by a know, thumb-turn, lever or similar mechanism.

Solid core door means a door composed of solid wood or compressed wood equal in strength to solid wood construction.

Stile is a vertical framing member of a window or door. A meeting stile is one which mates with a stile of another sash, or a vertical framing member of a door or window frame when the sash is in the closed position.

Strike is a metal plate attached to or mortised into a door jamb to receive and to hold a projected latch bolt and/or deadbolt in order to secure the door to the jamb.

Swinging door means a door hinged at the stile or at the head and threshold.

U.L listed means tested and listed by Underwriters Laboratories, Inc.

Vandal resistant cover is a protective cover constructed of either acrylic, polycarbonate or wire mesh which totally encloses the light source. The wire mesh must have a maximum 1/4-inch mesh. The polycarbonate and acrylic must have a minimum 1/2-inch thickness. The purpose of the cover is to discourage the willful destruction of the light source.

Visibility corridor is an opening of at least a ten-inch square and shall be located a minimum of thirty-six (36) inches and not to exceed fifty (50) inches above ground level.

Window assembly is a unit composed of a group of parts or components which make up a closure for an opening in a wall or roof (including the anchorage) to control light, air, and other elements.

Window frame is that part of a window which surrounds and supports the sashes and is attached to the surrounding wall. The members include side jambs (vertical), head jamb (upper, horizontal), sill and mullions.

(Ord. No. NS-1424, § 1, 6-5-78; Ord. No. NS-1436, § 1, 8-21-78; Ord. No. 1794, § 2, 10-14-85)

Sec. 8-202. Definition of "enforcing authority".

As used in this division, the term "enforcing authority" shall mean the building official and his authorized representatives.

(Ord. No. NS-1424, § 1, 6-5-78; Ord. No. NS-1794, § 3, 10-14-85; Ord. No. NS-1900, § 6, 6-1-87)

Sec. 8-203. Enforcement.

The enforcing authority is hereby empowered and directed to administer and enforce the provisions of this division relating to physical security requirements for buildings in the City of Santa Ana. Plans and specifications for proposed construction must be approved, by the enforcing authority in accordance with the provisions of this division. No building permit is to be finally approved or utility release given



unless the applicant for said permit or release has satisfied the enforcing authority that applicant has complied with this division.

(Ord. No. NS-1794, § 4, 10-14-85)

Sec. 8-204. Violations and penalties.

It shall be unlawful for any person, firm or corporation to erect, construct, enlarge, move, improve, convert, equip, use, occupy or maintain any building or structure in the City of Santa Ana or cause the same to be done, contrary to or in violation of any of the provisions of this division.

(Ord. No. NS-1424, § 1, 6-5-78)

Sec. 8-205. Alternate materials and methods of construction.

Materials, methods of construction or structural design limitations provided for in this division are to be used unless an exception is granted.

The use of any material or method of construction not specifically prescribed by this division may be allowed, provided any such alternate method or material has been approved by the enforcing authority prior to use.

Further, other sound methods of structural design or analysis not specifically provided for in this division may be allowed provided such alternative has been approved by the enforcing authority prior to use.

The enforcing authority may approve any such alternate provided that they find the proposed design to be satisfactory and the material and method of work offered is for the purpose intended, at least equivalent to that prescribed in this division in quality, strength, effectiveness, crime resistance, durability and safety.

(Ord. No. NS-1424, § 1, 6-5-78)

Sec. 8-206. Appeals.

The Uniform Code appeals board shall have the power and be required to hear appeals regarding determination of the suitability of alternate materials and methods of construction, and to provide for reasonable interpretation of the provisions of this division in the event of a dispute.

(Ord. No. NS-1424, § 1, 6-5-78; Ord. No. NS-1596, § 3, 9-8-81)

Cross reference(s)--Uniform Code appeals board established, § 2-450

Sec. 8-207. Keying requirements.

Upon occupancy by the owner or proprietor, each single unit in a tract or commercial development, constructed under the same general plan, shall have locks using combinations which interchange free from locks used in all other separate dwellings, proprietorships or similar distinct occupancies within

such tract or commercial development. Every applicant shall be required to provide the enforcing authority with written confirmation of compliance with the above requirements.

(Ord. No. NS-1424, § 1, 6-5-78)

Sec. 8-208. Garage-type doors.

(a) Garage-type doors, which are either rolling overhead, solid overhead, swinging, sliding, or accordion style doors shall conform to the following standards:

(1) Wood doors shall have panels a minimum of five-sixteenths (5/16) inch in thickness with the locking hardware being attached to the support framing.

(2) Aluminum doors shall be a minimum thickness of .0215 inches and riveted together a minimum of eighteen (18) inches on center along the outside seams. There shall be a full width horizontal beam attached to the main door structure which shall meet the pilot, or pedestrian access, door framing within three (3) inches of the strike area of the pilot or pedestrian access door.

(3) Fiberglass doors shall have panels a minimum of six (6) ounces per square foot from the bottom of the door to a height of seven (7) feet. Panels above seven (7) feet and panels in residential structures have a density of not less than five (5) ounces per square foot.

(b) Where sliding or accordion doors are utilized, they shall be equipped with guide tracks which shall be designed so that the door cannot be removed from the track when in the closed and locked position.

(c) Doors that exceed sixteen (16) feet in width shall have two (2) lock receiving points, one (1) located on each side of the door. Doors not exceeding sixteen (16) feet shall have one (1) lock receiving point placed on either side of the door. A single bolt may be used in the center of the door with the locking point located either in the floor or door frame header.

(d) All overhead or swinging doors shall be equipped with slidebolts which shall be capable of utilizing padlocks with a minimum nine-thirty-seconds (9/32) inch shackle.

(1) The entire slidebolt assembly shall be constructed of case-hardened steel and shall have a frame a minimum of .120 inches in thickness, and a bolt diameter a minimum of one-half (1/2) inch, and shall protrude at least one and one-half (1 1/2) inches into the receiving guide.

(2) Slide bolt assemblies shall be attached to the door with bolts which are nonremovable from the exterior. Rivets shall not be used to attach such assemblies.

(e) Padlocks used with exterior mounted slide bolts shall have a hardened steel shackle a minimum of nine-thirty-seconds (9/32) inch in diameter with heel and toe locking and a minimum five (5) pin tumbler operation. The key shall be nonremovable when in an unlocked position.

(f) Doors utilizing a cylinder lock shall have a minimum five (5) pin tumbler operation with the bolt or locking bar extending into the receiving guide a minimum of one (1) inch.

(g) Pedestrian access doors contained in garage type doors shall comply to the standards set forth in section 8-211 (b) or (e).

(Ord. No. NS-1424, § 1, 6-5-78; Ord. No. NS-1794, § 5, 10-14-85)

Sec. 8-209. Windows and sliding glass doors.

The following requirements must be met for windows and sliding glass doors:

(a) Except as otherwise specified in section 8-210 (Special residential building provisions) and section 8-211 (Special commercial building provisions), all openable exterior windows and sliding glass doors shall comply with the tests as set forth in section 8-212 (Tests).

(b) Louvered windows shall not be used when any portion of the window is less than twelve (12) feet vertically or six (6) feet horizontally from an accessible surface or any adjoining roof, balcony, landing, stair tread, platform or similar structure.

(Ord. No. NS-1424, § 1, 6-5-78)

Sec. 8-210. Special residential building provisions.

The following special provisions shall apply to all residential dwellings.

(a) All exterior swinging doors shall be of solid core construction with a minimum thickness of one and three-fourths (1 3/4) inches, or with panels not less than nine-sixteenths (9/16) inch thick.

(b) Any swinging door leading from a garage into a residence shall be of solid core construction with a minimum thickness of one and three-eighths (1 3/8) inches.

(c) The above-described doors shall be equipped with a single cylinder deadbolt having a minimum projection of one (1) inch and an embedment of at least three-fourths (3/4) inch into the strike receiving the bolt. The bolt shall be constructed so as to resist cutting tool attacks. The cylinder shall have a cylinder guard, a minimum of five (5) pin tumblers, and shall be connected to the inner portion of the lock by connecting screws of at least one-fourth (1/4) inch diameter.

The provisions of this subsection do not apply where panic hardware is required or an equivalent device is approved by the enforcing authority. Further, a dual locking mechanism, constructed so that both deadbolt and latch can be retracted by a single action of the inside door knob or lever, may be utilized provided it meets all other specifications for locking devices.

(d) Installation and construction of frames and jambs for exterior swinging doors shall be as follows:

(1) Door jambs shall be installed with solid backing in such a manner that no voids exist between the strike side of the jamb and the frame opening for a vertical distance of six (6) inches each side of the strike. Finger joints are prohibited within twelve (12) inches vertically of any locking device.

(2) In wood framing, horizontal blocking shall be placed between studs at door lock height for three (3) stud spaces each side of the door openings. Trimmers shall be full length from the heads to the floor with solid backing against soles plates.

(e) The inactive leaf of double doors shall be equipped with metal flushbolt(s) having a minimum embedment of five-eighths (5/8) inch into the head and threshold of the door frame.

(f) Glazing in exterior doors or within forty (40) inches of a door locking mechanism shall be of fully tempered glass or rated burglary resistance glazing.

(g) Hinges for outswinging exterior doors shall be equipped with nonremovable hinge pins or a mechanical interlock to preclude removal of the door from the exterior by removing the hinge pins.

This requirement shall also apply to exterior hinges on any swinging door which leads from a garage into a residence.

(h) Strikeplates shall be constructed of minimum sixteen (16) U.S. gauge steel, bronze or brass a minimum of three and one-half (3 1/2) inches in length and secured to the jamb with screws a minimum of two and one-half (2 1/2) inches in length.

(i) All front exterior doors shall be equipped with a wide angle one hundred eighty (180) degree door viewer, except where clear vision panels are installed.

(j) When panic hardware is required by the Uniform Building Code or Title 24, California Administrative Code, it shall be equipped and installed as follows:

(1) Panic hardware shall contain a minimum of two (2) locking points on each door, one (1) located at the header, the other at the threshold of the door; or

(2) On single doors, panic hardware may have one (1) locking point which is not to be located at either the top or bottom rails of the door frame. The door shall have an astragal constructed of steel .125 inches thick which shall be attached with nonremovable bolts or welded to the outside of the door. The astragal shall extend a minimum of six (6) inches vertically above and below the latch of the panic hardware. The astragal shall be a minimum of two (2) inches wide and extend a minimum of one (1) inch beyond the edge of the door.

(3) Double doors containing panic hardware shall have a full length steel astragal attached to the doors at their meeting point which will close the opening between them but not interfere with the operation of either door.

(k) The following provisions for address markings shall apply to residential dwellings:

(1) All residential structures shall display a street number in a prominent position so that it shall be easily visible from the street. The numbers shall be four (4) inches in height, of a color contrasting to the background and located so they may be clearly seen and read. If the structure has rear vehicle access, numbers shall be placed there as well.

(2) At each driveway entrance to a multiple-family dwelling complex or a private residential community which has access from a public roadway, there shall be an illuminated diagrammatic representation (plot plan) of the complex which shows the location of the viewer and the building units within the complex.

(3) In multiple-family dwelling complexes, any building having a separate identifying factor other than the street number shall be clearly identified in the manner described in subsection (k), infra. Each individual unit of residence shall have a unit identifying number, letter or combination thereof displayed upon the door.

(4) Buildings shall be numbered with the approval of the enforcing authority.

(5) This section shall not prevent supplementary numbering such as reflective numbers on street curbs or decorative numbering but this shall be considered supplemental only and shall not satisfy the requirements of this section.

(6) Maps of the complex shall be furnished to the police and fire departments upon completion of construction. The maps shall include building identification and unit identification.

(1) All exterior doors shall be equipped with a lighting device which shall provide a minimum maintained one (1) footcandle of light at ground level during hours of darkness. Lighting devices shall be protected by vandal resistant covers.

(m) Aisles, passageways and recesses related to and within multiple-family dwelling complexes shall be equipped with lighting devices which shall provide a minimum maintained one (1) footcandle of light at ground level during hours of darkness. Lighting devices shall be protected by vandal resistant covers.

(n) All parking lots, carports, garages and parking structures of multiple-family dwelling complexes shall be equipped with lighting devices which will provide a minimum maintained one (1) footcandle of light on the parking surface during hours of darkness. Subterranean parking lots shall maintain lighting twenty-four (24) hours a day. Lighting devices shall be protected by vandal resistant covers.

(o) All exterior required lighting devices shall be placed at a height which will fully illuminate an average adult.

(p) In multiple-family dwelling complexes where a common laundry is supplied, the laundry room's access door shall be equipped with a window, self closure device and self locking door lock which can be manually disengaged on the interior. Lighting shall be maintained inside the laundry room during hours of darkness.

(q) When access to or within a multiple-family dwelling complex or private residential community is unduly difficult because of secured openings or where immediate access is necessary for lifesaving or fire fighting purposes, a key override is to be installed in an accessible location. The key override shall be mastered to both fire department and police department keys.

(r) All skylights on the roof of any residential structure shall be provided with rated burglary resistant glazing.

(s) Passenger elevators, the interiors of which are not completely visible when car door(s) is open, shall have mirrors so placed as to make visible the whole of the elevator interior to prospective passengers outside the elevator.

(t) Whenever a mail slot is located within forty (40) inches of the primary locking device on any exterior door, it shall be covered by an interior hood which will discourage manipulation of the primary locking device.

(u) All exterior block wall fencing of multiple-family dwelling complexes shall have intervals providing visibility corridors, which will allow visibility of the interior from outside the wall, and these visibility corridors shall be placed at regular intervals. These will be required on the side facing the street only.

(v) Permanently affixed ladders leading to roofs shall be fully enclosed with sheet metal to a height of ten (10) feet. This covering shall be locked against the ladder with a case hardened hasp, secured with nonremovable screws or bolts and a padlock with a minimum three-eighths (3/8) inch hardened steel shackle, locking at both heel and toe, and a minimum five (5) pin tumbler operation with nonremovable key when in an unlocked position. Hinges on the cover will be provided with nonremovable pins when using pin type hinges.

(Ord. No. NS-1424, § 1, 6-5-78; Ord. No. NS-1436, § 2, 8-21-78; Ord. No. NS-1794, § 6, 10-14-85)

Sec. 8-211. Special commercial building provisions.

(a) Swinging exterior glass doors, wood or metal doors with glass panels, solid wood or metal doors shall be constructed or protected as follows: (electronic sliding doors are prohibited)

(1) Wood doors shall be of solid core construction with a minimum thickness of one and three-fourths (1 3/4) inches. Hollow metal doors shall be constructed of a minimum equivalent to sixteen (16) U.S. gauge steel and have sufficient reinforcement to maintain the designed thickness of the door when any locking device is installed; such reinforcement being able to restrict collapsing of the door around the locking device.

(2) Except when double cylinder deadbolts are utilized or safety glazing is required by Chapter 54 of the Uniform Building Code, any glazing installed within forty (40) inches of any door locking mechanism shall be constructed or protected as follows:

a. Fully tempered glass or rated burglary resistant glazing; or

b. Iron or steel grills of at least one-eighth (1/8) inch mesh secured with nonremovable bolts on the inside of the glazing may be utilized; and framing for iron or steel grills shall be by one (1) inch by one-fourth (1/4) inch flat metal secured by nonremovable bolts; or

c. The glazing shall be covered with iron or steel bars of at least one-half (1/2) inch round or one (1) inch by one-fourth (1 x 1/4) inch flat metal, spaced not more than five (5) inches apart and secured with nonremovable bolts.

d. Items b. and c. above shall not interfere with the operation of opening windows if such windows are required to be openable by the Uniform Building Code.

(b) All swinging exterior doors with the exception of aluminum frame swinging doors shall be equipped as follows:

(1) A single or double door shall be equipped with a double or single cylinder deadbolt. The bolt shall have a minimum projection of one (1) inch and be constructed so as to repeal cutting tool attack. The deadbolt shall have an embedment of at least three-fourths (3/4) inch into the strike receiving the projected bolt. The cylinder shall have a cylinder guard, a minimum of five (5) pin tumblers, and shall be connected to the inner portion of the lock by connecting screws of at least one-fourth (1/4) inch in diameter. All deadbolts will be equipped with a locked indicator. Exposed installation screws on double cylinder deadbolts shall be nonremovable. The provisions of this subsection do not apply where (1) panic hardware is required, or (2) an equivalent device is approved by the enforcing authority. Locking devices shall be mounted at a height of not less than thirty (30) nor more than forty-four (44) inches above the finished floor.

(2) Hinges for outshowing doors shall be equipped with nonremovable hinge pins or a mechanical interlock to preclude removal of the door from the exterior by removing the hinge pins.

(3) Whenever a mail slot is located within forty (40) inches of the primary locking device on any exterior door it shall be covered by an interior hood which will discourage manipulation of the primary locking device.

(4) Strikeplates shall be constructed of minimum sixteen (16) U.S. gauge steel, bronze or brass, a minimum of three and one-half (3 1/2) inches in length and secured to the jamb with screws a minimum of two and one-half (2 1/2) inches in length.

(c) All exterior double doors shall be equipped as follows:

(1) The inactive leaf of double doors shall be equipped with automatic releasing metal flushbolts having a minimum embedment of five-eighths (5/8) inch into the header and threshold of the door frame or by panic hardware which contains a minimum of two (2) locking points, one (1) located at the header the other at the threshold of each door.

(2) Double doors shall have a full length astragal, constructed of steel a minimum of .125 inch thick which will cover the opening between the doors. The astragal shall be a minimum of two (2) inches wide, and extent a minimum of one (1) inch beyond the edge of the door to which it is attached. The astragal shall be attached to the outside of the active door by means of welding or with nonremovable bolts spaced apart on not more than ten (10) inch centers.

(d) Aluminum frame swinging doors shall conform to the following:

(1) The jamb on all aluminum frame swinging doors shall be so constructed or protected to withstand one thousand six hundred (1,600) pounds of pressure in both a vertical distance of three (3) inches and a horizontal distance of one (1) inch each side of the strike, so as to prevent violation of the strike.

(2) Aluminum frame swinging doors shall be equipped with a two-point locking mechanism consisting of deadbolt having a minimum bolt projection of one and one-half (1 1/2) inches, or a hook shaped or similar bolt that engages the strike sufficiently to prevent spreading and a metal automatic releasing threshold bolt having a minimum embedment of five-eighths (5/8) inch into the floor. The deadbolt lock shall have a minimum of five (5) pin tumblers, and a cylinder guard and shall be equipped with a locked indicator.

(e) Panic hardware, whenever required by the Uniform Building Code or Title 24, California Administrative Code, shall be equipped and installed as follows:

(1) Panic hardware shall contain a minimum of two (2) locking points on each door, one (1) located at the header, the other at the threshold of the door; or

(2) On single doors, panic hardware may have one (1) locking point which is not to be located at either the top or bottom rails of the door frame. The door shall have an astragal constructed of steel .125 inch thick which shall be attached with nonremovable bolts to the outside of the door. The astragal shall extend a minimum of six (6) inches vertically above and below the latch of the panic hardware. The astragal shall be a minimum of two (2) inches wide and extend a minimum of one (1) inch beyond the edge of the door to which it is attached.

(3) Double doors containing panic hardware shall have a full length astragal constructed of steel, attached to the doors at their meeting point which will close the opening between them, but not interfere with the operation of either door.

(f) Installation and construction of frames and jambs for exterior swinging doors shall be as follows:

(1) Door jambs shall be installed with solid backing in such a manner that no voids exist between the strike side of the jamb and the frame opening for a vertical distance of six (6) inches each side of the strike. Finger joints are prohibited.

(2) In wood framing, horizontal blocking shall be placed between studs at door lock height for three (3) stud spaces each side of the door openings. Trimmers shall be full length from the heads to the floor with solid backing against sole plates.

(g) In multiple occupancy office buildings all entrance doors to individual office suites shall meet the construction and locking requirements for exterior doors.

(h) In multiple occupancy buildings, interior walls dividing the individual suites shall not end at the false ceiling but shall continue to the real roof.



(i) Exterior transoms or windows shall be deemed accessible if less than twelve (12) feet above ground or adjacent to any pedestrian walkway. Accessible windows and transoms having a pane or opening exceeding ninety-six (96) square inches, with the smallest dimension exceeding six (6) inches, and not visible from a public or private thoroughfare shall be protected in the following manner:

(1) Fully tempered glass or burglary resistant glazing; or

(2) The following window barriers may be used but shall be secured with bolts, which are nonremovable from the exterior:

a. Interior or exterior steel or iron bars of at least one-half (1/2) inch round or one by one-quarter (1 x 1/4) inch flat metal spaced not more than five (5) inches apart and securely fastened; or

b. Interior or exterior iron or steel grills of at least one-eighth (1/8) inch metal with not more than a two (2) inch mesh and securely fastened.

(3) The protective bars or grills shall not interfere with the operation of opening windows if such windows are required to be openable by the Uniform Building Code.

(j) Roof openings shall be equipped as follows:

(1) All skylights on the roof of any building or premises used for business purposes shall be provided with:

a. Rated burglary resistant glazing; or

b. Iron or steel bars of at least one-half (1/2) inch round or one by one-fourth (1 x 1/4) inch flat metal spaced not more than five (5) inches on center to cross the narrowest dimension of the opening being covered. If the narrowest dimension of that opening exceeds eighteen (18) inches, cross members shall be welded into place, not more than eighteen (18) inches apart beginning with a cross member at the center of the opening. Cross members shall be welded to each and every bar it crosses. The entire bar assembly shall be mounted inside the skylight and shall be attached to the building structure by means of machine bolts spaced not more than sixteen (16) inches apart or attached by means of an equivalent method approved by the enforcing authority; or

c. A steel or iron grill of at least one-eighth (1/8) inch metal with a maximum two (2) inch mesh mounted inside the skylight and secured by bolts which are nonremovable from the exterior.

d. These requirements do not apply on any structure with a height of thirty-five (35) feet or more where there is no readily available roof access as determined by the enforcing authority.

(2) All hatchway openings on the roof or any building or premises used for business purposes shall be secured as follows:

a. If the hatchway is of wooden material, it shall be covered on the inside with at least sixteen (16) U.S. gauge sheet steel, or its equivalent, attached with screws.

b. The hatchway shall be secured from the inside with a slide bar or slide bolts which are attached by nonremovable bolts.

c. Outside hinges on all hatchway openings shall be provided with nonremovable pins when using pin-type hinges.

(3) All air duct or air vent openings exceeding ninety-six (96) square inches on the roof or exterior walls of any commercial building shall be secured by covering same with either of the following:

a. Iron or steel bars of at least one-half (1/2) inch round or one by one-fourth (1 x 1/4) inch flat metal spaced no more than five (5) inches apart and securely fastened; or

b. Iron or steel grills of at least one-eighth (1/8) inch metal with a maximum two (2) inch mesh and securely fastened.

c. If the barrier is on the outside, it shall be secured with bolts which are nonremovable from the exterior.

d. The above must not interfere with venting requirements, creating potentially hazardous conditions to health and safety, or conflict with the provisions of the Uniform Building Code or Title 19, California Administrative Code.

(k) Permanently affixed ladders leading to roofs shall be fully enclosed with sheet metal to a height of ten (10) feet. This covering shall be locked against the ladder with a case hardened hasp, secured with nonremovable screws or bolts and a padlock with a minimum three-eighth (3/8) inch hardened steel shackle, locking at both heel and toe, and a minimum five (5) pin tumbler operation with nonremovable key when in an unlocked position. Hinges on the cover will be provided with nonremovable pins when using pin-type hinges.

(l) A building located within eight (8) feet of utility poles, trees or similar structures which allow access to the building's roof, windows or other openings shall have such access area barricaded or fenced with materials to deter human climbing.

(m) The following standards for lighting and address markings shall apply to commercial buildings:

(1) The address number of every commercial building shall be located and displayed so that it shall be easily visible from the street. The numerals in these numbers shall be no less than six (6) inches in height and be of a color contrasting to the background. In addition, any business which affords vehicular access to the rear through any driveway, alleyway or parking lot shall also display the same numbers on the rear of the building.

(2) All exterior doors shall be equipped with a lighting device which shall provide a minimum maintained one (1) footcandle of light at ground level during hours of darkness. Lighting devices shall be protected by vandal resistant covers.

(3) All parking lots, and access thereto, providing more than ten (10) parking spaces and for use by the general public, shall be provided with a minimum maintained one (1) footcandle of light on the parking surface from dusk until the termination of business every operating day. At all other hours of darkness, a minimum maintained .25 footcandles of light shall be provided at ground level.

(4) Exterior lighting shall not shine away from subject property.

(n) Interior night lighting shall be maintained in those areas that are visible from the street (ground floors only).

(o) All exterior block wall fencing shall have intervals providing visibility corridors which will allow visibility of the interior from outside the wall, and these visibility corridors shall be placed at regular intervals. This applies only to block walls visible from the street.

(p) Passenger elevators, the interiors of which are not completely visible when the car door(s) is open, shall have mirrors so placed as to make visible the whole of the elevator interior to prospective passengers outside the elevator.

(q) When access to or within a commercial complex is unduly difficult because of secured openings or where immediate access is necessary for life saving or fire fighting purposes, a key override is to be installed in an accessible location. The key override shall be mastered to both the fire department and police department keys.

(r) Any structure four (4) stories in height or greater will have a repeater installed in its roof.

(s) Establishments having specific type inventories shall be protected by the following alarm service:

(1) Silent alarm system with a central station hook-up and required twenty-four-hour supervised service:

a. Jewelry store--Manufacturing, wholesale or retail.

b. Any establishment manufacturing, storing or selling firearms and ammunition.

c. Establishments selling or storing wholesale liquor, tobacco or drugs.

d. Facilities selling or storing furs.

e. Precious metal storage facilities.

f. Banks, savings and loan institutions and credit unions.

(2) Silent alarm system not requiring a central station hookup or supervised service:

a. Liquor stores.

b. Pawnshops.

c. Establishments manufacturing, storing or selling electronic equipment.

- d. Establishments dealing in coins and stamps.
- e. Establishments manufacturing, storing or selling industrial tool supplies.
- f. Establishments manufacturing, storing or selling cameras.

(3) Local or audible alarm system:

- a. Antique dealers.
- b. Art galleries.
- c. Service stations.
- d. Food markets.

(4) Nothing in this subsection shall preclude the use of an alarm system providing a higher level of security than that which is required.

(Ord. No. NS-1424, § 1, 6-5-78; Ord. No. NS-1502, § 1, 10-1-79; Ord. No. NS-1794, § 7, 10-14-85)

Sec. 8-212. Tests.

(A) Tests, general.

(1) It shall be the responsibility of the owner, or his designated agent, of a building or structure falling within the provisions of this division to provide the enforcing authority with a written specification performance test report indicating that the materials utilized meet the minimum requirements.

(2) Whenever there is insufficient evidence of compliance with the provisions of this division or evidence that any material or any construction does not conform to the requirements of this division, or in order to substantiate claims for alternate materials or methods of construction, the enforcing authority may require tests as proof of compliance to be made at the expense of the owner or his agent by any agency which is approved by the enforcing authority.

(3) Specimens shall be representative, and the construction shall be verified by assembly drawings and bill of materials. Two (2) complete sets of manufacturer or fabricator installation instructions and full-size or accurate scale templates for all items and hardware shall be included.

(B) Sliding glass door tests/procedures.

(1) The construction and size of the test door assemblies, jambs and headers, and all hardware components shall be representative of that for which acceptance is desired. The door assembly and mounting in the support fixture shall simulate the rigidity normally provided to a door assembly in a building by the ceiling, floor and walls.

(2) Sample doors submitted for testing shall be glazed. Panels shall be closed and locked with the primary locking device only.

(3) Tests shall be performed on the samples in the following order:

(a) With the panels in the test position, a concentrated load of eight hundred (800) pounds shall be applied to the vertical pull stile incorporating a locking device, at a point on the stile within six (6) inches of the locking device, in the direction parallel to the plane of the glass that would tend to open the door. With the load removed, determine if the primary locking device can be unlocked by manipulation as described in Test (1), infra.

(b) With panels in the test position, a concentrated load of fifty (50) pounds shall be applied to the vertical pull stile incorporating a locking device, at a point on the stile within six (6) inches of the locking device, in the direction parallel to the plane of the glass that would tend to open the door while, simultaneously, an additional concentrated load of two hundred (200) pounds is applied to the same area of the same stile in a direction perpendicular to the plane of glass toward the interior side of the building. With the load applied, determine if the primary locking device can be unlocked by manipulation as directed in Test (1), infra.

(c) Repeat test (b) substituting eight hundred (800) pounds for the indicated fifty (50) pounds. Perform the manipulation tests with the load removed.

(d) With the panels in the test position, a concentrated load of fifty (50) pounds shall be applied to the vertical pull stile incorporating a locking device, at a point on the stile within six (6) inches of the locking device, in the direction parallel to the plane of the glass that would tend to open the door while simultaneously, an additional concentrated load of two hundred (200) pounds is applied to the same stile in the direction perpendicular to the plane of the glass toward the exterior side of the door. With the load applied, determine if the primary locking device can be unlocked by manipulation as described in Test (1), infra.

(e) Repeat Test (d) substituting eight hundred (800) pounds for the indicated fifty (50) pounds. Perform the manipulation tests with the load removed.

(f) With the movable panel lifted upward to its full limit within the confines of the door frame, a concentrated load of eight hundred (800) pounds shall be applied separately to each vertical pull stile incorporating a locking device, at a point on the stile within six (6) inches of the locking device, in the direction parallel to the plane of the glass that would tend to open the door. With the load removed, determine if the primary locking device can be unlocked by manipulation as described in Test (1), infra.

(g) With the movable panel lifted upward to its full limit within the confines of the door frames, a concentrated load of fifty (50) pounds shall be applied to the vertical pull stile incorporating a locking device, at a point on the stile within six (6) inches of the locking device, in the direction parallel to the plane of the glass that would tend to open the door while, simultaneously, an additional concentrated load of two hundred (200) pounds is applied to the same area of the same stile in the direction perpendicular to the plane of the glass toward the interior side of the door. With load applied, determine if the primary locking device can be unlocked by manipulation as described in Test (1), infra.

(h) Repeat Test (g) substituting eight hundred (800) pounds for the indicated fifty (50) pounds. Perform the manipulation tests with the load removed.

(i) With the movable panel lifted upward to its full limit within the confines of the door panel, a concentrated load of fifty (50) pounds shall be applied to the vertical stile incorporating a locking device, at a point on the stile within six (6) inches of the locking device, in the direction parallel to the plane of glass that would tend to open the door while, simultaneously, and additional concentrated load of two hundred (200) pounds is applied to the same area of the same stile in the direction perpendicular to the plane of the glass toward the exterior side of the door. With the load applied, determine if the primary locking device can be unlocked by manipulation as described in Test (1), infra.

(j) Repeat Test (i) substituting eight hundred (800) pounds for the indicated fifty (50) pounds. Perform the manipulation tests with the load removed.

(k) For inside sliding doors, repeat Test (d) while simultaneously applying a concentrated load of fifty (50) pounds at the end of the movable bottom rail near the meeting stiles inward. For outside sliding doors, repeat Test (d) while simultaneously applying a concentrated load of fifty (50) pounds at the end of the movable bottom rail near the meeting stiles and outward.

(l) Lift, push, pull, or otherwise manipulate by hand the door relative to the clearances within the frame while attempting to open the door. This test shall be conducted continuously for five (5) minutes. Examine the assembly and determine a method and position for inserting a tool through the assembly from the outside so as to contact the primary locking device or the latch. Two (2) different tools shall be used: A knife or spatula with a thin blade approximately one-thirty-second ( $1/32$ ) inch thick, not more than one (1) inch wide and no longer than six (6) inches; and a piece of stiff steel wire with a diameter of approximately one-sixteenth ( $1/16$ ) inch. Determine whether it is possible to insert the wire or manipulate with either of these tools so as to unlock the door within a five-minute time period.

(m) With the following tools:

1. A knife or spatula with a thin blade approximately one-thirty-second ( $1/32$ ) inch thick, not more than one (1) inch wide, and no longer than six (6) inches; and
2. A straight or Phillips screwdriver with a maximum six (6) inch shaft.

Remove from the door assembly all screws, glazing heads, or other mechanical fasteners which can be removed readily from the exterior within a time limit of five (5) minutes. Determine if the primary locking device can be unlocked or entry gained by manipulation as described in Test (1), infra.

(4) Fixed panels. Fixed panels shall be fastened in accordance with the manufacturer's instructions. Tests shall be performed in the following order:

(a) With the panels in the normal position, a concentrated load of three hundred (300) pounds shall be applied at midspan of the fixed jambstile in the direction parallel to the plane of the glass that would

tend to remove the fixed panel from the frame jamb pocket. With the load applied, determine if entry can be gained by manipulation as described in subsection (B)(3)(1), infra.

(b) With the panels in the normal position, a concentrated load of three hundred (300) pounds shall be applied at midspan of the fixed jambstile in the direction parallel to the plane of the glass that would tend to remove the fixed panel from the frame jamb pocket while, simultaneously, an additional concentrated load of one hundred fifty (150) pounds is applied at midspan of the fixed panel interlock stile in the direction perpendicular to the plane of the glass which would tend to disengage the meeting stiles. With this load applied, determine if entry can be gained by manipulation as described in subsection (B)(3)(1), infra.

(c) Repeat Test (a) with the fixed panel lifted upward to its full limit within the confines of the door frame. The lifting force need not exceed one hundred fifty (150) pounds at the bottom of the exterior face of the meeting stile. With this load applied, determine if entry can be gained by manipulation as described in subsection (B)(3)(1), infra.

(5) A sliding door assembly shall fail these tests if at any time during or after the test, the sliding door assembly does not remain engaged, intact, and in the closed and locked position or by manipulating an exposed component; or if one can enter through displaced or damaged portions.

(6) The report shall include the following: Identification of the samples tested; type, size, location, and number of locking devices; type, location, and number of anchors; type and thickness of glazing material and an indication of whether or not the subject passed the test. The report shall also indicate at what point the assembly fails. The report shall be certified to be a true copy by the testing laboratory and shall be forwarded direct from the laboratory to the enforcing authority.

(C) Window classifications.

(1) Type A window assemblies incorporate one (1) or more sashes that open by sliding in the plane of the wall in which the window is installed.

(2) Type B window assemblies incorporate one (1) or more framed sashes which are hinged at or near two (2) corners of the individual sash and open toward the exterior of the wall.

(3) Type C window assemblies incorporate one (1) or more sashes which open toward the interior and are hinged at or near two (2) corners of the sash.

(4) Type D window assemblies incorporate one (1) or more sashes which are hinged or pivot near the center so that part of the sash opens into the interior wall and part opens toward the exterior.

(D) Window tests/procedures.

(1) Window assemblies shall be mounted following the manufacturer's installation instructions. Install the window assembly in a test fixture which simulates the wall construction required by Chapter 25 of

the Uniform Building Code. The unit shall be fully glazed. The sash shall be closed and locked with the primary locking device only.

(2) Tests for Type A window assemblies shall be performed in the following order:

(a) With the sliding sash in the normal position, a concentrated load of two hundred (200) pounds shall be applied separately to each member incorporating a locking device, at a point on the sash member within six (6) inches of the locking device, in the direction parallel to the plane of the glass that would tend to open the window. With the load removed, apply the manipulation test described in subsection (B)(3)(1), supra.

(b) With the sliding sash in the normal position, a concentrated load of two hundred (200) pounds shall be applied separately to each sash member incorporating a locking device, at a point on the sash member within six (6) inches of the locking device in the direction parallel to the plane of the glass that would tend to open the window while, simultaneously, an additional concentrated load of seventy-five (75) pounds is applied in the same area of the same sash member in the direction perpendicular to the plane of the glass toward the interior side of the window. With the load removed, apply the manipulation test described in subsection (B)(3)(1), supra.

(c) With the sliding sash in the normal position, a concentrated load of two hundred (200) pounds shall be applied separately to each sash member incorporating a locking device, at a point on the sash member within six (6) inches of the locking device, in the direction parallel to the plane of the glass that would tend to open the window while, simultaneously, an additional concentrated load of seventy-five (75) pounds is applied to the same area of the same sash member in the direction perpendicular to the plane of the glass toward the exterior side of the window. With the load removed, apply the manipulation test described in subsection (B)(3)(1), supra.

(d) With the sliding sash lifted upward to the full limit within the confines of the window frame, a concentrated load of two hundred (200) pounds shall be applied separately to each sash member incorporating a locking device, at a point on the sash within six (6) inches of the locking device, in the direction parallel to the plane of glass that would tend to open the window. With the load removed, apply the manipulation test described in subsection (B)(3)(1), supra.

(e) With the sliding sash lifted upward to the full limit within the confines of the window frame, a concentrated load of two hundred (200) pounds shall be applied separately to each sash member incorporating a locking device, at a point on the sash within six (6) inches of the locking device, in the direction parallel to the plane of the glass that would tend to open the window while, simultaneously, an additional concentrated load of seventy-five (75) pounds is applied to the same area of the same sash member in the direction perpendicular to the plane of the glass towards the interior side of the window. With the load removed, apply the manipulation test described in subsection (B)(3)(1), supra.

(f) With the sliding sash lifted upward to the full limit within the confines of the window frame, a concentrated load of two hundred (200) pounds shall be applied separately to each sash member incorporating a locking device, at a point on the sash member within six (6) inches of the locking device,



in the direction parallel to the plane of the glass that would tend to open the window while, simultaneously, an additional concentrated load of seventy-five (75) pounds is applied to the same area of the same sash member in the direction perpendicular to the plane of the glass toward the exterior side of the window. With the load removed, apply the manipulation test described in subsection (B)(3)(1), supra.

(g) For inside sliding windows, repeat Test (f) while simultaneously applying a concentrated load of twenty-five (25) pounds inward at the end of the movable bottom rail near the meeting stile opposite the lockstile. For outside sliding windows, repeat Test (f) while simultaneously applying a concentrated load of twenty-five (25) pounds in the same direction as the perpendicular load inward at the end of the movable bottom rail near the meeting stile opposite the lock stile outward.

(h) Perform the disassembly and manipulation test as described in subsection (B)(3)(m), supra.

(3) The tests for Types B and C window assemblies shall be performed in the following order:

(a) With the swinging sash in the normal position, apply a concentrated load of one hundred (100) pounds within three (3) inches of each end of the rail or stile which is opposite the hinged side, in the direction perpendicular to the plane of the glass that would tend to open the window.

(b) Repeat Test (a) and simultaneously apply a concentrated load of one hundred (100) pounds on the outside within one (1) inch of the end of the stile or rail which is opposite the hinged side, in a direction parallel to the plane of the glazing which would tend to disengage the lock.

(c) With the swinging sash in the normal position, apply a concentrated load of two hundred (200) pounds on the rail or stile containing the locking device within six (6) inches of the lock.

(d) Repeat Test (b) while simultaneously applying Test (c). The manipulation test described in subsection (B)(3)(1), supra, shall be applied in Tests (a), (b) and (d) to the sash with the load removed.

(e) Perform the disassembly and manipulation test as described in subsection (B)(3)(m), supra.

(4) Tests for Type D window assemblies shall be performed in the following order:

(a) With the sash in the normal position, simultaneously apply a concentrated load of one hundred (100) pounds within three (3) inches of the ends of each rail or stile which is perpendicular to the pivot sides in the direction that would tend to open the sash.

(b) With the sash in the normal position, apply a concentrated load of one hundred (100) pounds on the rail or stile containing the pivot within one (1) inch of the pivot in a direction parallel to the pivots.

(c) Repeat Test (b), applying the load to the opposite rail or stile.

(d) With the sash in the normal position, apply a concentrated load of two hundred (200) pounds on the rail or stile containing the locking device within six (6) inches of the lock.

(e) Repeat Test (d) while simultaneously applying the load specified in Test (b). Repeat Test (d) while simultaneously applying the load specified in Test (c) above. The manipulation test described in subsection (B)(3)(1), supra, shall be applied in Tests (a), (b), (c) and (d) above to the sash with the load removed.

(f) Perform the disassembly and manipulation test as described in subsection (B)(3)(m), supra.

(5) A window assembly shall fail these tests if at any time during or after the tests, the assembly does not remain engaged, intact, and in the closed and locked position, or by manipulating exposed component; or if one can enter through displaced or damaged portions.

(6) The report shall contain a description of the results of the test performed in accordance with the test methods above. The report shall include the following: Identification of the samples tested; type, location, and number of anchors; type and thickness of glazing material and an indication of whether or not the subject passed the test. The report shall also indicate at what point the assembly fails. The test report shall be certified to be a true copy by the testing laboratory and shall be forwarded direct from the laboratory to the enforcing authority.

(Ord. No. NS-1424, § 1, 6-5-78)