

Chapter 13

Historic Structures Guidelines



The Bowers Museum

13.1 INTRODUCTION

History is an important part of Santa Ana's character. Founded in 1869 by William Spurgeon, and selected as Orange County's seat since the county's creation in 1889, Santa Ana has witnessed over 100 years of Southern California's urban development. The City's rich sense of history and architectural heritage is apparent throughout Santa Ana's neighborhoods and downtown. The purpose of this Chapter is to provide guidelines and illustrations necessary

to maintain the fabric of Santa Ana's historic and architectural resources.

The historic preservation effort in Santa Ana is a key contributing factor in the overall revitalization of the community. By the early 1980s, the City had seen the loss of many invaluable historic structures and the decline of many of its neighborhoods, primarily due to the intrusion of architecturally insensitive buildings and additions. In an effort to protect and revitalize the historic fabric of the City, the city adopted a new chapter in the Santa Ana Municipal Code and the Register of Historical Properties (The Register), which is a local list of individual structures of architectural or historic significance to the community. To oversee the Register, the City formed the Historic Resources Commission (HRC). All exterior modifications, including repairs, rehabilitation, restoration and additions of these structures require review and approval by the HRC, in addition to any building permit requirement.



The Maharajah House

13.2 GENERAL DESIGN OBJECTIVES

Santa Ana contains a wide variety of architectural styles, all of which contribute to the charm and unique character of each neighborhood. The objectives of the design guidelines provided in the section are as follows:

- Preserve structures with notable historic or architectural value.
- Adhere to a high standard of quality when preserving, rehabilitating, and restoring historic structures.
- Preserve the character-defining features of architectural styles.
- Protect the unique character and integrity of historic resources by maintaining existing architectural styles.
- Enhance the visual character of the City by encouraging the preservation of unique and established architectural traditions.
- Continue the existing pattern of development in terms of building massing, setbacks, location of buildings on the site and streetscape.



13.3 APPLICABILITY

The Historic Structures Design Guidelines apply to all structures listed on the Santa Ana Register of Historical Properties.

For reference, the City has two historic districts listed on the National Register of Historic Places: Downtown Santa Ana, composed of two sub-districts, and French Park (Figures 13-1 and 13-2). Santa Ana’s downtown is geographically larger than the Historic Districts and encompasses areas developed with non-historic buildings. Because of its unique architectural and land use characteristics, the design guidelines for downtown are addressed in Chapter 8.

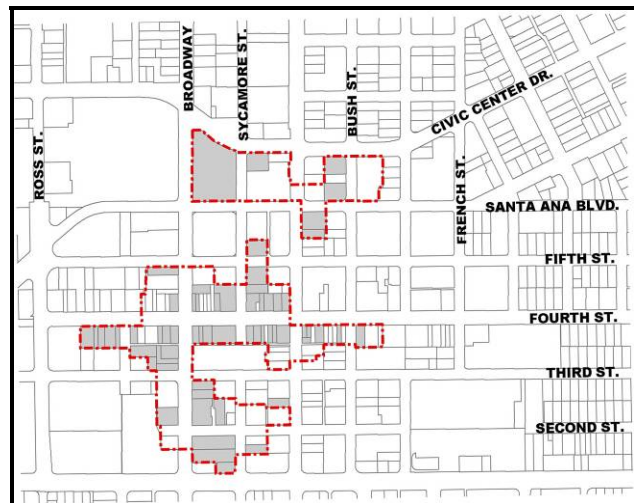

*Figure 13-1: Downtown Historic Districts:
Northern and Southern Districts*

Chapter 8 addresses design guidelines for historically significant buildings, as well as design guidelines for additions and new infill projects. Property owners with non-residential historic structures may benefit from perusing Chapter 8, as guidelines for

storefronts, building entries, security doors, and other architectural amenities common to non-residential buildings are discussed at length.

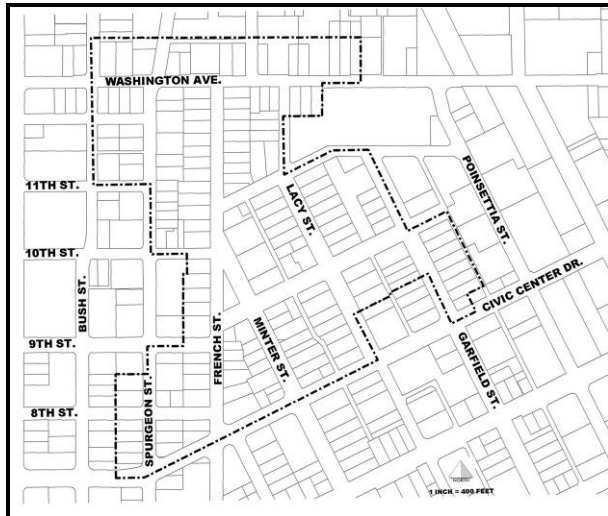

Figure 13-2: French Park Historic District Specific Development 19

Properties in the French Park Historic District generally are also located within a special zoning district known as Historic French Park Specific Development (SD-19). Proposed projects within SD-19 will need to be consistent with the design guidelines adopted as part of the SD-19. Lastly, while the Heninger Park Historic District (Figure 13-3) is not a registered historic district, but a zoning district known as Specific Development 40 (SD-40), it has its own adopted design standards based on the Secretary of the Interior’s Standards. Proposed projects in SD-40 must be consistent with the design standards adopted for this zoning classification.

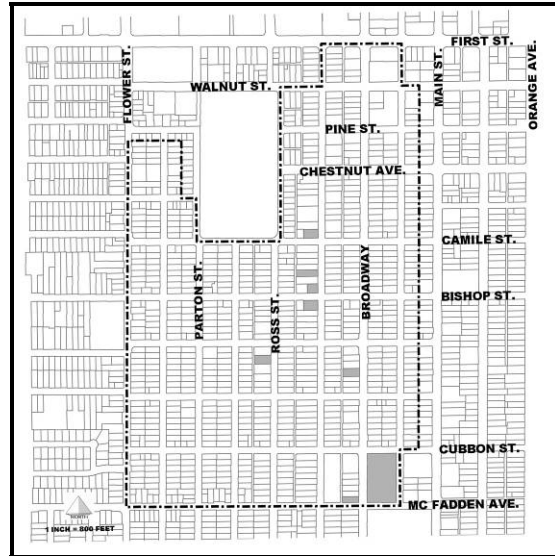

Figure 13-3: Heninger Park Historic District Specific Development 40

13.4 SECRETARY OF THE INTERIOR’S STANDARDS

The following guidelines are based on the *Secretary of the Interior’s Standards for the Treatment of Historic Properties* (The Standards) (Refer to **Appendix C** for a copy of the complete standards). The Standards were originally established by the Secretary of the Interior to determine the appropriateness of work to be done on properties qualifying for the Federal Tax program. Subsequently, many state and local governments have adopted the standards for the review of individually listed properties on a local, state or federal register and for historic preservation projects within locally designated historic districts.



Tibbs Residence photo courtesy Guy Ball

As described in the Technical Bulletin published by the National Park Service, “there are four distinct, but interrelated, approaches to the treatment of historic properties:

As a Certified Local Government (CLG) through the State of California Office of Historic Preservation, the City of Santa Ana is required to use of the Secretary of the Interior’s Standards. The alteration and rehabilitation of structures listed on the City of Santa Ana’s Register of Historical Properties, the California Register, or the National Register must comply with the intent of the Standards.

The Standards provide general information to determine appropriate approach to treatments of historic properties. They are written in broad and general terms to apply to many conditions. They are designed to assist in the understanding of the basic concepts and principles of preservation, rehabilitation, commonly referred as adaptive re-use, restoration and reconstruction.

- **Preservation** – focuses on the maintenance and repair of existing historic materials and retention of a property’s form as it has evolved over time. Protection and Stabilization have now been consolidated under this treatment.
- **Rehabilitation** – acknowledges the need to alter or add to a historic property to meet continuing or changing uses while retaining the property’s historic character.
- **Restoration** – depicts a property at a particular period of time in its history, while removing evidence of other periods.
- **Reconstruction** – re-creates vanished or non-surviving portions of a property for interpretative purposes.”

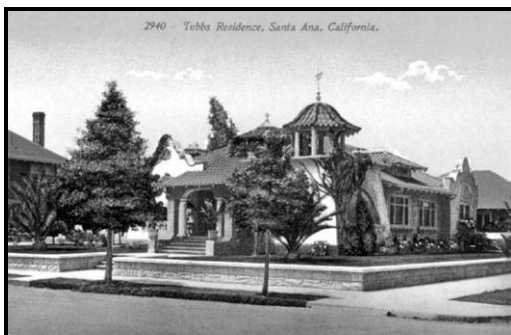

*South Birch Street, Pre 1900
photo courtesy Guy Ball*



*View from the Courthouse tower prior to 1966
photo courtesy Guy Ball*

13.5 PRESERVATION INCENTIVES

As a commitment to the preservation of historic structures, the City, the State and the Federal government have adopted several types of incentives designed to make the investment in these properties more rewarding (Refer to **Appendix E** for a comprehensive listing of programs). If you would like to take advantage of the available incentives, please contact the City of Santa Ana Planning Division. Additionally, please contact the State Historic Preservation Office (SHPO) prior to beginning any proposed work. Removing or altering any exterior or interior features of the structure prior to SHPO consultation could immediately disqualify your project for tax credits.

13.6 HISTORIC BUILDING GUIDELINES

Preservation, and rehabilitation efforts in Santa Ana are aimed at maintaining and protecting the original character defining architectural features of the structure, as these help to identify its style and contribute to the overall historic

character of the area. Rehabilitation and repair not only increases property values, but also serves as an inspiration to other property owners and designers to undertake similar efforts.

The guidelines presented in the following section will focus on **preservation** and **rehabilitation**, (adaptive re-use) of historically significant structures. Property owners looking for guidelines to assist with the restoration of their building are encouraged to explore the websites referenced in **Appendix G**.

These guidelines should be utilized whenever repairs or alterations are contemplated to the exterior facade of a building¹.



*Las Casitas on North Broadway
photo courtesy Guy Ball*

¹ Some specific tips and advice for repair (e.g. repair of foundations and siding, etc.) are found in Appendix C This section is intended for guidance only – project applicants should consult the Planning Division for additional guidance and to determine permit requirements.

13.6.1 General Guidelines

- a. Owners should conduct research before designs for alterations or rehabilitation are prepared. Research should include determining the appearance of the building at the time of original construction and a physical examination to determine if the significant historic fabric has been altered and is recoverable or restorable or can be reconstructed.
- b. **Appendix A** presents a starting point for research of an architectural style. More specific information can be found through research at the History Room in the main Santa Ana Library, which contains old photographs, books about the style that describe typical features, observing similar buildings in the neighborhood and previous owners.
- c. The character-defining features of the style need to be preserved and not removed or altered.
- d. It is always better to repair an original architectural feature than to replace it. However, when an architectural feature cannot be repaired and replacement is necessary, every effort should be made to use an original historic construction material. The substitute material should incorporate the design, pattern, texture, thickness, width, color and form to convey the visual appearance of the original

materials. Simulated replacement materials (e.g. artificial stone or vinyl) are highly discouraged.

- e. When an entire piece of a building is missing (e.g. original porch columns), research can be very helpful in understanding the functional and aesthetic ideas behind the original style and form.
- f. Rehabilitation efforts should not try to create or add a preconceived concept of history, but should reuse the existing or appropriate features.

13.6.2 Foundations

- a. The original foundations should be maintained to the extent feasible. Only the portion of the foundation in need of repair should be repaired or replaced.



Figure 13-4: Foundations should be consistent with the architectural style of the building

- b. Foundations materials should be consistent with the architectural style of the building.



Figure 13-5: Foundation structural elements and mortar should match the original design

- c. The application of mortar or other structural elements or features should match the original design and craftsmanship (Refer to Figure 13-5).
- d. Vents or other openings should preserve the original vent style in size, material and color. When replacement is necessary, vent and hardware styles should be consistent with the original design.

13.6.3 Exterior Wall

- a. When repairing or remodeling exterior wall surfaces, the original exterior building materials should be retained where possible and when applicable should be cleaned with the gentlest means possible – never sandblasted. Replacement material should match the original materials as closely as possible. Do not use mismatched materials of different types, sizes, shapes, textures or finishes.

- b. Buildings with original wood siding should not be stuccoed in an attempt to "modernize" their appearance. Material substitutions such as these will invariably destroy the architectural integrity of the building and decrease its resale value.

13.6.4 Wood Siding and Shingles

A number of Santa Ana’s significant architectural styles are clad in wood siding and shingles, namely Victorian Era homes (Italianate, Stick, Queen Anne), Colonial Shingle Revival, and Craftsman. Throughout the community, the appearance of wood sided buildings helps define the historic character.



Figure 13-6: Example of decorative wood shingles

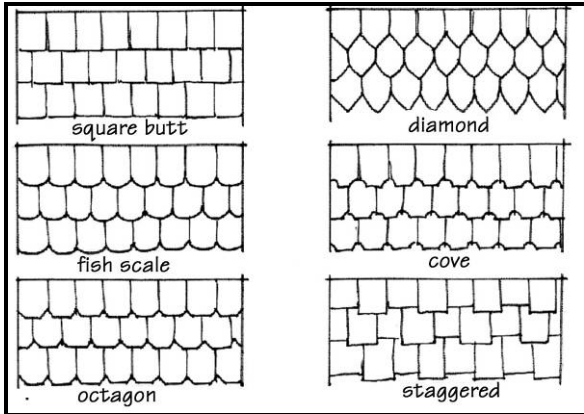

Exhibit 13-7: Examples of Shingle Patterns



Figure 13-8: Example of clapboard

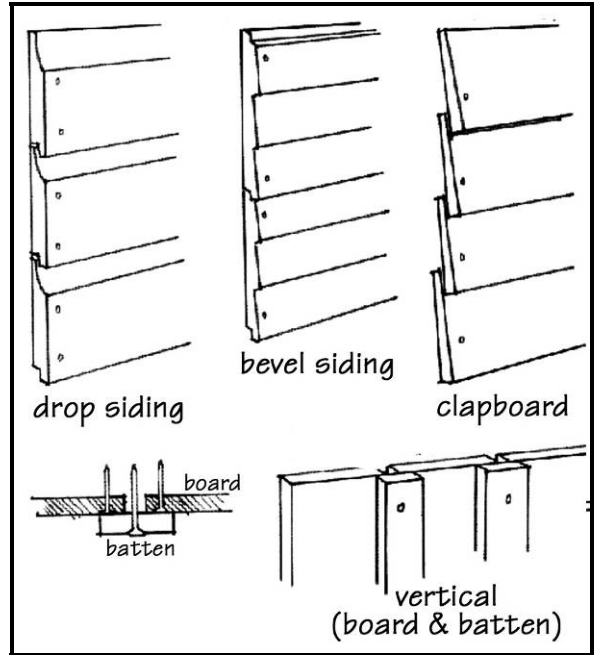

Exhibit 13-9: Examples of horizontal and vertical siding applications

a. Wood siding and shingles should be retained rather than removed and replaced with alternative materials, such as aluminum or vinyl siding, asphalt shingles or masonite, even of the same size and shape as the original siding.

b. Stain or varnish should not be applied over historically painted surfaces nor should heavy spray-on coatings (texture coat) or sealants be applied over wood siding. These applications will decrease the historic value of the house.

c. The following methods are not recommended when repairing wood siding:

- Replacing wood siding with wood of a different size or shape.
- Applying paint without proper surface preparation and priming.
- Sandblasting wood to remove excess paint.

13.6.5 Brick and Masonry

Brick and masonry is often found in foundation walls, chimneys and exterior walls throughout Santa Ana. (e.g. Tudor/Provincial, Prairie, Craftsman). The following guidelines apply to brick and masonry;

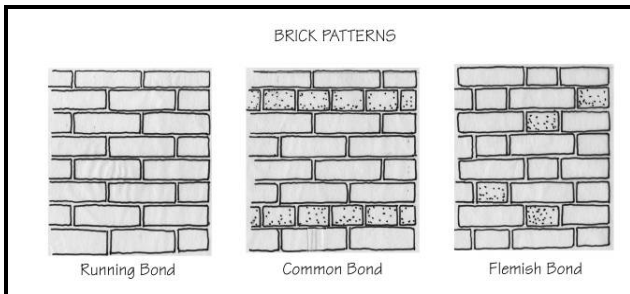

Figure 13-10: Examples of traditional brick patterns

- a. If it is necessary to replace a few bricks within an existing wall, the new bricks need to match the existing size, color, pattern and texture to the greatest extent possible.
- b. Repair of mortar joints (repointing) should be performed by experienced professionals. If the job is improperly done, it can detract from the appearance of the home and cause physical damage.
- c. The following are inappropriate when repairing brick/masonry:
 - Using sandblasting to remove paint or dirt, as it will damage the natural fired surface of the brick and reduce water repellent qualities.

- Using mechanical grinders/sanders to remove mortar that can damage the brick surrounding a joint.

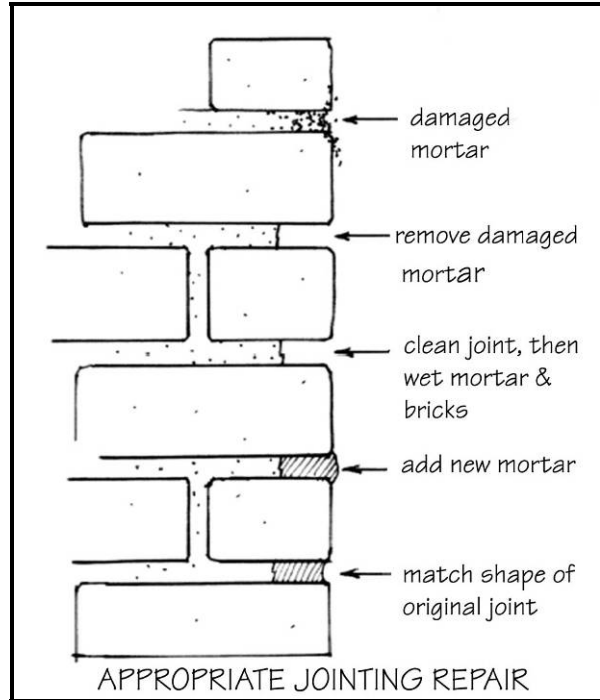

Figure 13-11: Example of appropriate jointing repair

- d. In most cases, brick and masonry walls were installed in the natural appearance and should be kept in that condition when renovating.

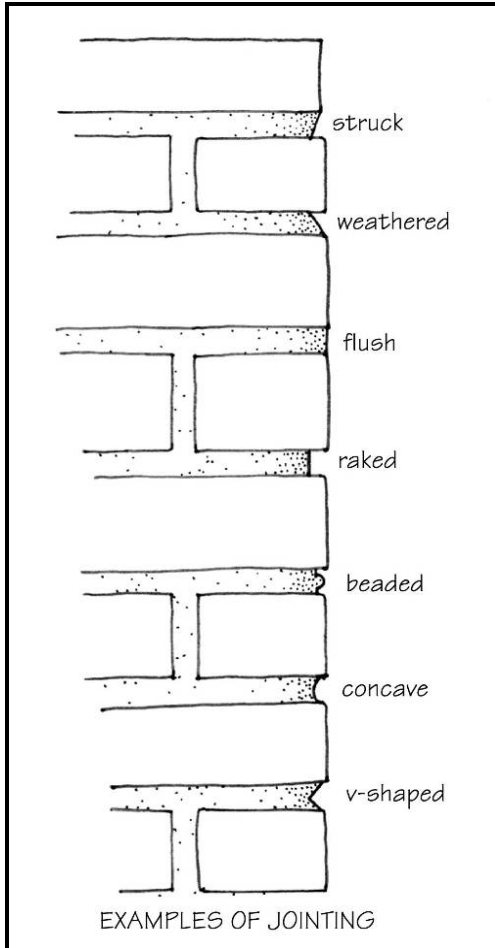

Figure 13-12: Examples of various jointing types

13.6.6 Exterior Plaster

Exterior plaster or stucco is a common surface material of Spanish Colonial/Mission/Monterey style houses and Mediterranean revivals.



Figure 13-13: Example of exterior plaster (stucco)

- a. Stucco should not be applied to structures with original wood siding.
- b. Exterior plaster has a natural tendency to crack and should be repaired promptly after decay is noticed. It is easy to repair following manufacturer's instructions.
- c. Stucco/plaster should be applied with a hand trowel versus a spray application.
- d. Plaster texture and pattern should match the style of the period.
- e. When repairing stucco/plaster the following methods are not recommended:
 - Patching plaster without removing all loose pieces and thoroughly cleaning the patch area.
 - Patching plaster without creating a "locked joint" to form between old and new materials.

13.6.7 Porches and Stairs

For many of Santa Ana house styles the front porch is one of the most important architectural features defining a structure while adding character to a street. The porch adds visual interest to the overall appearance of the house and creates a pleasant, welcoming passage into the house that has

traditionally received the greatest amount of detail work and decoration.



Figure 13-15: Example of typical Victorian-era porch detail

- a. Avoid changes in the structural or decorative elements of the front porch as it will jeopardize the architectural integrity of the house. The design integrity can be compromised by changing the details of the original porch design such as roof overhangs, stairs and rails, support columns, balusters, decorative work, etc.
- b. When a deteriorated porch needs to be rebuilt, the reconstruction should follow the original design of each of the existing elements of the porch (Refer to Figures 13-16 and 13-17).

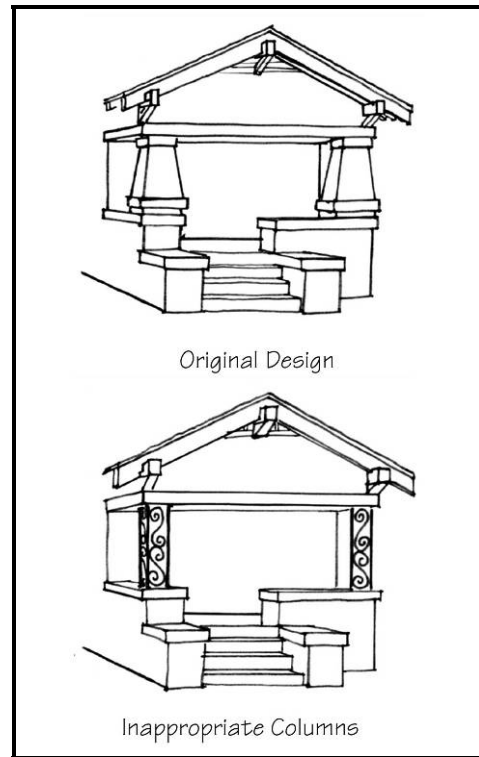

Figure 13-16: Example of Inappropriate column replacement

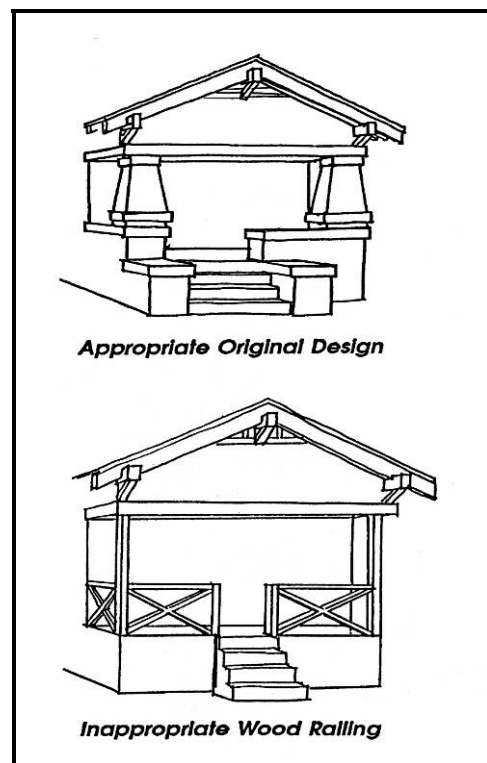

Figure 13-17: Porch railings should match the original design

c. The stairs leading to the porch can be an important part of the overall style of the house. When stairs require rehabilitation they should be rebuilt according to the style of the house. Especially avoid the use of the off-the-shelf, ready-made wrought iron railings and oversimplified construction methods that reduce the visual importance of stairs (Refer to Figure 13-18).

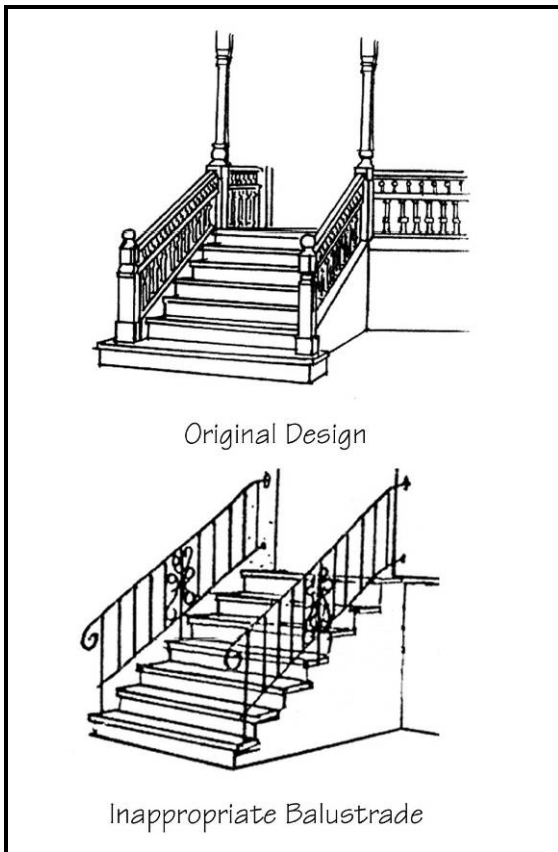

Figure 13-18: Avoid inappropriate replacement of stairways, balustrades and railings.

d. Enclosing the front porch with solid walls, additional columns and windows is an inappropriate means of creating additional

interior space. This practice should be avoided as it is extremely difficult to maintain the architectural integrity of a house that has had its porch altered (Refer to Figure 13-19).



Figure 13-19: Avoid enclosing the front porch.

e. The following methods are not recommended when repairing porches or stairs:

- Using aluminum canopies or incongruous balustrades or handrails.
- Changing the original angle of the porch roof (generally porch roofs have the same angle as the roof of the structure).
- Permanently enclosing porches and railings with darkened glass, solid walls or permanent screens.)

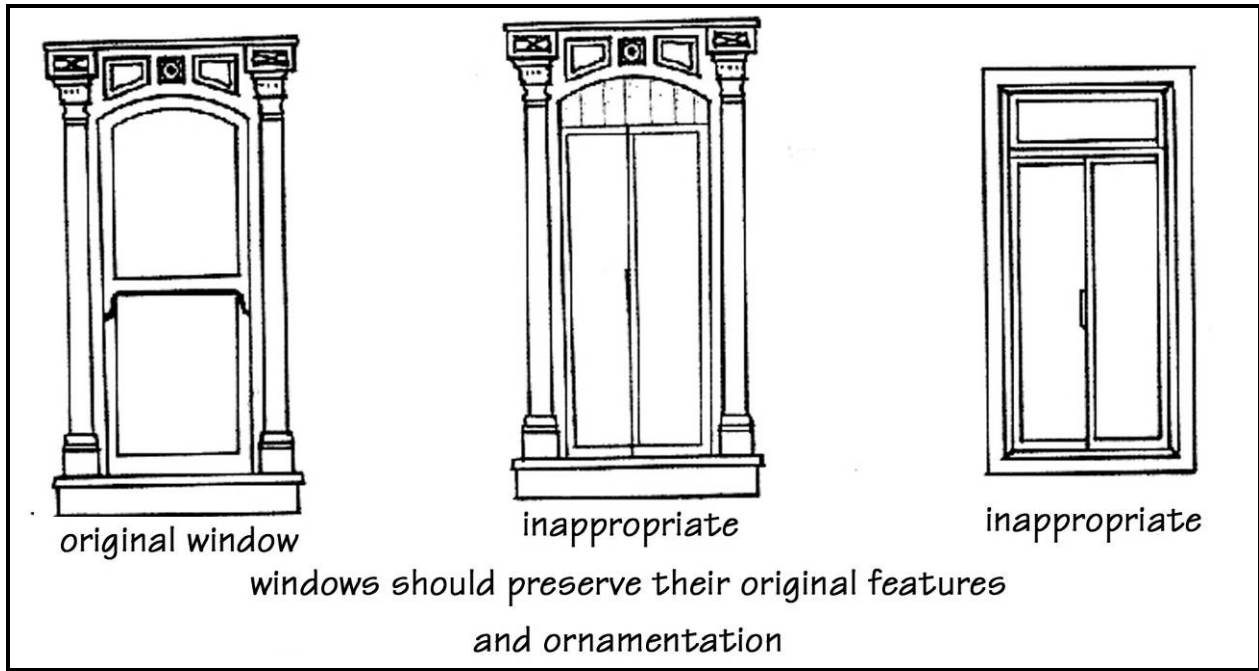

Figure 13-19: A window's original features should be preserved

13.6.8 Windows

The size, shape and style of windows are an important architectural feature of most architectural styles and replacement of original windows with inappropriate material can significantly alter the historic appearance of a structure. Over time, a neighborhood can lose its historic character through insensitive window change outs.

The impact of windows on the facade is determined by the size, shape, and pattern of openings, spacing and placement within the facade. Most historic buildings have wood windows that were either fixed, double hung or casement.

a. The original window should be maintained and repaired

whenever possible, especially on elevations visible from the public right-of-way.

b. When altering or reconstructing windows, consideration of the following elements is crucial to retaining the structure's original architectural balance and integrity.

- Original window openings should be retained.
- Original windows and frames should be saved and restored. Missing, rotting, or broken sashes, frames, mullions, and muntins should be replaced with like materials.
- If the original window openings have been

altered, the openings should be restored to their original configuration and detail. Blocking or filling window openings that contribute to the overall facade design is inappropriate.

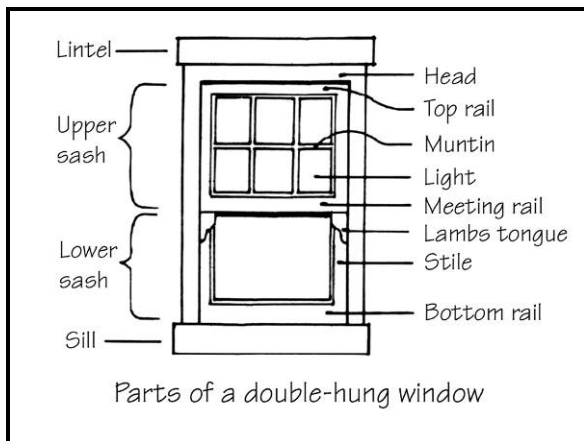

Figure 13-20: Example of double-hung window

- c. When window replacement is necessary, the new window should match the original as closely as possible. This may require custom milling but the extra effort will be worth it in the long run because the original style and character of the building will be maintained (Refer to Figure 13-19).
- d. An "off-the-shelf" standard window that very closely matches the original window may be allowable in some cases as an alternative to custom milling (for instance, it may provide an alternative for areas of the building that are not visible from the public street).

- e. Replacement windows should be of the same operating type, size, light pattern and detailing as the original window.
- f. Aluminum, vinyl or vinyl clad windows and frames are inappropriate replacements for buildings on the Register. These windows are highly distinguishable and the contrast of styles and materials can permanently destroy the architectural integrity of the building.
- g. Windows of historic buildings should not be modified through tinting, or reflective materials. Avoid the use of reflective coatings or other treatments on glass surfaces.
- h. The exterior window trim and surround can be a major character-defining feature on historic buildings. Every effort should be made to repair original trim.
- i. If the trim is too deteriorated to repair, or missing, then it should be replaced with like materials and match as closely as possible to the original.

13.6.9 Doors

Most architecturally significant buildings in Santa Ana have wood doors that are particular to their style. The front door of the building is always the most ornate while secondary doors are usually more utilitarian and

plain. The size, shape and style of doors are an important feature of an architectural style and the original type should be retained.

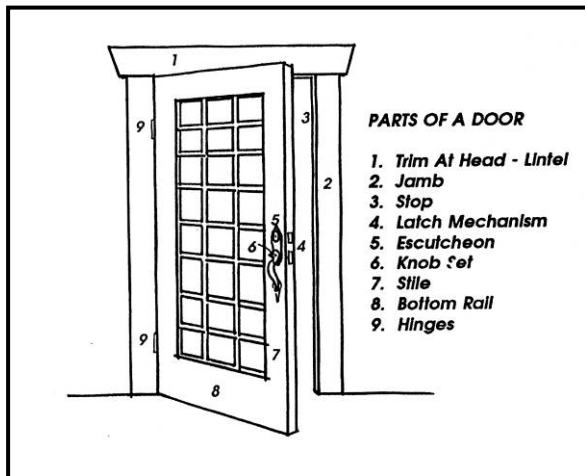

Figure 13-21: Example of door components

- a. Original doors should be repaired in-place when possible, but when replacement is necessary they should be replaced to match the original design, size and materials.
- b. If the original door is missing, select an appropriate design by studying the doors of similar houses or buildings in town or consulting architectural style books. Many types of solid panel doors are available directly from material suppliers and home improvement centers that may match original doors. Specialty milling may be necessary for some types of doors. Salvage retailers are a good resource for authentic materials and styles.
- c. Doors that are not compatible with the original style of the building are inappropriate, especially in

locations that are visible from the street.

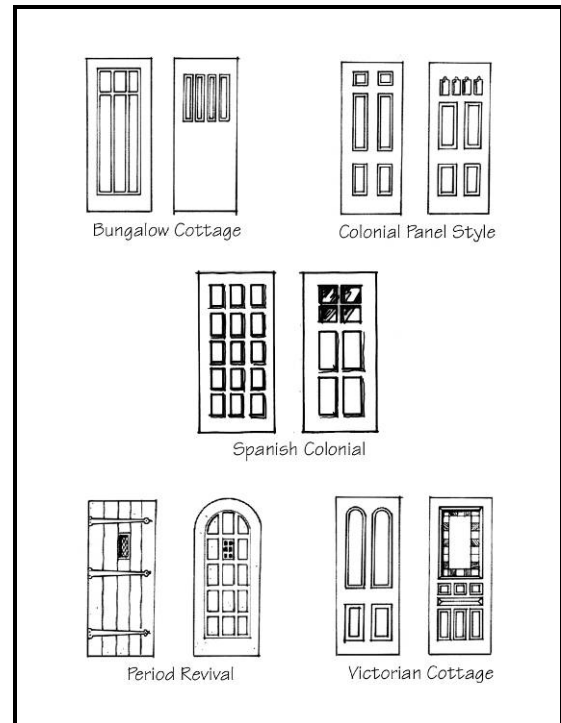

Figure 13-22: Examples of various door types by architectural style.

- d. Do not use hollow core doors for exterior doors.
- e. The use of mismatched hardware or materials inappropriate to the style should be avoided.

13.6.10 Ornamentation/Trim

Often, it is the authentic decoration and trim on a building that lends the character to help identify the architectural style. Great care should be taken in handling trim and decoration during renovation because many times they are the very components that make the building so special. Individuals preparing to engage in any such work

that will affect the appearance of an existing building's exterior should bring plans to the Planning Division prior to beginning. Refer to **Appendix A** for examples of typical ornamentation.

a. All existing exterior historic decoration should be preserved.



Figure 13-23: Historic detailing should be preserved

d. The application of too many coats of paint obscures details and should be avoided.



Victorian Era ornamentation

b. Original trim should not be removed or completely replaced when only minor patching or repair is sufficient.

c. Sandblasting should not be used to remove paint.



Art Moderne ornamentation

13.6.11 Roofs

Roofs are important functionally and aesthetically. As with most other exterior modifications, permits are required for re-roofing.



Figure 13-24: Thatched roofing is typical of the Tudor style.

a. When replacement of a roof is necessary, new roofing materials should be compatible with the original architectural style of the building.



Figure 13-25: Flat wood shingles are typical of the Victorian and Craftsman styles



Figure 13-26: Tile roofs and coping are typical of Spanish styles

b. The selection of roofing materials should take into account the architectural style of the building, and the shape of the roof (how prominent it is).

- The Historic Building Code allows the replacement of wood shingles or shakes. Often, the desire for the most aesthetic material is superseded by the desire to provide maximum fire protection. Many of the newer “architectural” styles of asphalt roofing closely emulates wood shingles or shakes and provides superior fire resistance. However, wood shingles or shakes can be pressure treated to achieve an equivalency of a Class C roofing material, which meets City requirements.

- Many companies still manufacture clay tile roofs, but challenges may arise when trying to match the color and shape of a particular tile. If new tile cannot be found that matches the existing tile, it is possible to obtain salvaged tiles from a home with similar roofing material that is being demolished or use the available tile that most closely matches the existing tile.
- c. The use of roofing materials or colors that are inappropriate to the style is unacceptable (*Refer to Figure 13-27*).
- f. Any roof equipment, such as vents should not be intrusive and placed out of public view.
- g. Eaves, fascias and soffits should be considered an integral part of the roof. Care should be taken to preserve the detailing and other character-defining elements of these features (*Refer to Figure 13-28*).
- h. Eaves and soffits should not be boxed or altered in a manner that affects the original construction.



Figure 13-27: Avoid the use of roofing materials that are inappropriate to the style



Figure 13-28: Eaves, fascias and soffits should preserve their original characteristics such as rafter tails

- d. Patching roofs with materials or color that do not match the rest of the roof is not appropriate.
- e. Patching clay tile roofs by “dumping” mortar on cracked tiles is not allowed.

13.6.12 Gutters, Downspouts, Flashing and Vents

Gutters and downspouts collect water from roofs and carry it to the ground away from the building. If these elements are deteriorated or absent altogether, water may run down the sides of the building and cause the paint to prematurely weather. Gutters and downspouts should be kept in proper working order periodically checking for leaks and clogged areas. Attic vents allow proper

ventilation in the attic and maintain the structural integrity of the building.

- a. Whenever possible, original gutters, downspouts and vents should be repaired and not replaced. Even these very utilitarian elements can contribute to the overall character of the structure, such as copper downspouts.
- b. When new gutters and downspouts are replaced or added, they should relate to the style and lines of the building and should be painted to match the trim or body color of the structure. They should not be painted a contrasting color so they stand out (*Refer to Figure 13-29 and 13-30*).

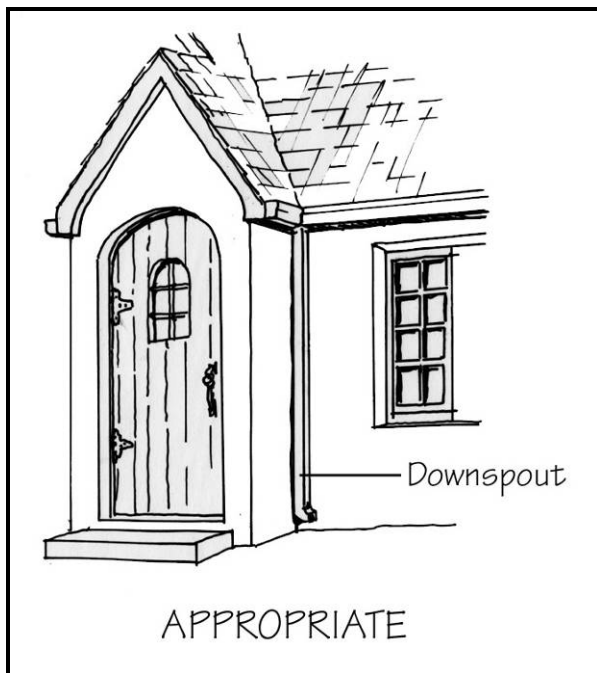

Figure 13-29: Example of appropriate location of downspout

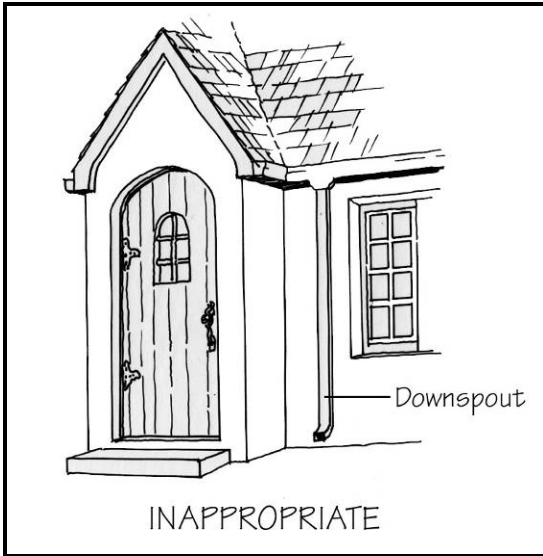

Figure 13-30: Avoid placement of downspouts in conspicuous locations

- c. Generally, new downspouts should be placed in the least conspicuous locations. Use the sides and rear of the building and avoid placing downspouts on the front facade.
- d. Vent pipes, flashing and stacks that protrude through the roof should be painted to match the color of the roof material.
- e. If vents are too deteriorated to repair, then they should be replaced with like materials to match the original design (Refer to Figure 13-31).



Figure 13-31: Vent replacement should match the original design

13.6.13 Paint Colors

The City of Santa Ana does not regulate paint colors. Therefore, this section is included for reference only. Painting can be one of the simplest and most dramatic improvements that can be made to a facade. It gives the facade a well-maintained appearance and is essential to the long life of many traditional elements. Choosing appropriate paint color can also be important to maintaining the historical integrity of a building. If some basic color guidelines are kept in mind, color can add to the richness and variety of Santa Ana, all the while respecting the traditions and heritage of the community.



Figure 13-32a: Example of color that is respectful of the period of the architectural style

Historically, certain color palettes were associated with particular architectural styles. As a result, the architectural style itself may dictate appropriate colors of a structure. The following guidelines should be used in evaluating exterior building colors, bearing in mind that there are always exceptions to the generalizations made above. These guidelines can

also be applied to infill development. For more specific examples of historic precedent for color, Refer to *Appendix F* of this document.



Figure 13-32b: Example of color that is respectful of the period of the architectural style

- c. The colors of all elements of a development including walls, accessory structures, fences, and signs should be compatible.



Figure 13-33: Color schemes should be compatible with exposed materials and detailing of the particular style

- a. Building color in established areas should be compatible and blend with surrounding buildings. The color should not be a “sign” or imply that the building is trying to attract attention. Color should not, because of its intensity, distinctness, chroma, or reflectivity, become the most dominant feature of a building site.
- b. “Compatible colors” does not mean that adjacent color schemes should be duplicated.

- d. Combinations of colors or tones on a single building or site which clash or create a discordant effect should be avoided.
- e. A building should be treated as consistently as possible. Exterior colors should be coordinated on all elevations and compatible with exposed materials, architectural style, and detailing.
- f. Color should not extend beyond the common building line and paint should not be used to obscure the integrity of natural building materials.

13.7 REPAIR AND CLEANING

This section provides a summary of generally accepted methods for the repair and cleaning of historic materials. The Secretary of the Interior’s guidelines should also be

consulted for more thorough discussion of repair and cleaning.

13.7.1 Foundations



The foundation holds the building frame to the ground. A foundation in poor condition threatens the structural integrity of the building. For this reason, the soundness of the building's foundation needs to be seriously investigated prior to considering a major building restoration project.

In cases where buildings were constructed without permanent foundations, (i.e. loose stones were laid down to keep the wooden frame off the ground), advice should be sought from a professional (i.e. architect, structural engineer) before proceeding with other restoration work. If your house has a masonry or concrete foundation check for the following symptoms of deterioration:

Cracks - Cracks can result from settling soil, water undermining or earthquakes. Concrete foundations will likely have minor hairline cracks that are not serious, but any cracking wider than a penny should be watched to determine if the cracking is continuing.

One simple way to check for movement is to draw a horizontal line across the crack with a straightedge and observe it for two to three weeks. If the lines across the crack have split, it means that the movement has occurred and a professional contractor, engineer or architect should be consulted. If cracking is seen and self-testing is not desirable, call a professional for further investigation. If the crack is determined not to be hazardous to the structure, aesthetics should guide the decision whether or not to patch the crack. Concrete can be patched with readily available concrete patch mixtures.

Water Damage - Water seeping through walls and into basements is a sign of poor drainage and/or improper waterproofing of walls. Deteriorated roof drainage systems, such as broken downspouts, can allow water to flow over walls or be drained directly onto the foundation of the building. Improper site drainage can cause surface water to run towards the building. These water-related problems can cause undermining and improper settlement of the footings. Constant dampness can cause deterioration of both brick and mortar. Simple remedies such as repairing downspouts or adjusting the grade to drain water away from the structure can alleviate many of these problems. However, a leaking exterior wall may need to be investigated by a professional to determine the proper remedy.

13.7.2 Exterior Wall Materials



Siding Repair - Cracked, split or missing wood siding can cause severe water problems by allowing water to deteriorate the wood stud wall or interior finish. While small cracks can be filled with caulking, larger cracks or missing pieces should be replaced. To replace a piece of wood siding, gently pry up the piece immediately above the piece to be replaced and cut the nails holding the unwanted wood with a hacksaw blade (removed from the hacksaw and held with a pair of gloves). Using a chisel, remove the unwanted wood and replace with new, matching siding. Re-nail the new area and apply caulk where the new piece touches adjoining pieces.

The most important element of protecting wood siding is the paint that protects the wood from weathering. The key to painting a wood exterior is proper preparation. The best paint job in the world will deteriorate rapidly if the surfaces are not properly prepared prior to the first coat of paint.

First, inspect the entire exterior and determine the general state of the existing paint. All crumbly, flaking, blistering and peeling paint must be removed. Evaluate the amount of work necessary to do the job correctly and decide whether or not to call in a painting contractor to help. Also, try to determine what might have caused the paint to deteriorate (peel, blister). There may be a reoccurring water problem that needs to be fixed first.

Surface Preparation The following steps should be taken prior to starting surface preparation:

- All wood siding should be repaired;
- All doors, windows and trim should be inspected for water tightness and caulked if necessary;
- Proper operation of windows should be checked and repaired;
- Windows should be inspected for damaged or deteriorated putty and repaired; and
- All gutters and downspouts should be inspected and repaired as necessary.

Surface preparation should include the use of a wire brush to remove dirt, plant growth and flaking paint. A scraper should be used to remove areas of blistering paint, followed by sanding to smooth down the transition between the scraped area and the adjacent painted area. Where damaged areas are large, heat paint removers may be the best solution,

but should be used strictly according to supplier recommendations. After the work area has been properly scraped and sanded, all exposed wood must be primed and then the whole area can be painted. A paint dealer will assist in determining the type of paint, brushes and quantities that will be needed.

Brick and Masonry- Brick and masonry is often found in foundation walls and chimneys of historic houses. Wall cracking and deteriorating mortar joints are the most common problems and should be addressed by a professional.

The first step in the process is to remove the old mortar to a depth of 3/4 inch and remove all loose mortar. Avoid the use of mechanical grinders, which can damage the brick surrounding the joint. Before applying the new mortar dampen the joint area. The new mortar must be composed of materials which closely match the original texture, color and strength of mortar used on the original house. When mortar application is completed and layer is thumbprint hard the joint should be tooled to match the historic joint.

Exterior Plaster - Exterior plaster has a natural tendency to crack but is generally easy to repair. Before starting the patching process, inspect the cracks thoroughly to determine if additional water damage occurred to other portions of the wall. Slightly bulging areas adjacent to the crack indicate that one or more coats of plaster have become separated from the previous coat.

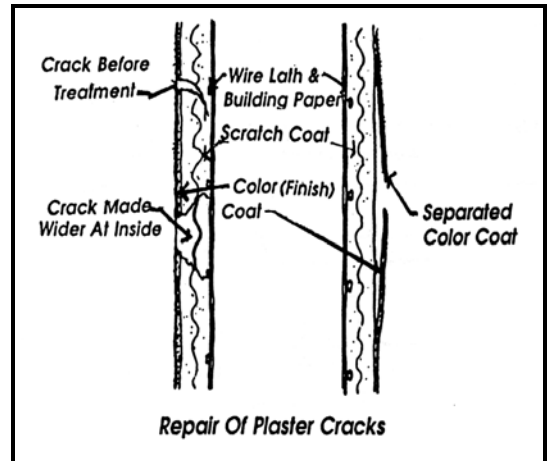

Figure 13-34: Example of appropriate repair of plaster cracks

Lightly tap the bulging areas with a hammer to remove all of the separated plaster and extended the repair area to include these areas. Use a putty knife to open a crack and remove loose debris. Use a hammer and a small cold chisel to make the crack wider at the inside than at the outside; this will allow a "locked" joint to form between the new and old materials. Be careful not to damage the lath below the plaster. Thoroughly clean and then wet the area to receive the patch so that the old material will not rob the new plaster of its moisture. Exterior plaster patch is readily available at most hardware stores and is easily mixed with water. Follow all manufacturers' instructions. Apply the patching material using a trowel to make the patch level with the adjacent surfaces. Consult the manufacturers' suggestions regarding any necessary curing (*Refer to Figure 13-34*).

Large areas of patching or sections which have to be replaced down to the stud wall should be handled by an experienced plasterer as it can be difficult to match some historic plaster textures.

13.7.3 Porches and Stairs



Check with the City's Building plan checker before you start any demolition or repair work. The project may be exempt from the provisions of the California Building Code (CBC), or if regulated, you may request the use of the State Historic Building Code that the City has adopted.

Wood Porch Repairs- There are three steps to the repair process which will return the porch to a safe state and attractive appearance.

1. Remove the ornamentation- Do so with extreme care and patience. Study the part first to see if is attached with a toe-nail or a face-nail. Use a broad surface of a prying instrument, like a crowbar, working it in very gradually to loosen the knobs from the supporting post and beams. When space allows, place a piece of

wood or corrugated cardboard between the tool and the structural wood to avoid denting the surface as you unnailed.

2. Repair or rebuild the porch structure- The structure of a wood porch consists of the posts for support, the joists and decking for the floor, the railings for safety, the columns for support and the porch roof, and the porch roof itself for overhead protection.

3. Repair the ornamentation and install it- Once the structure is repaired or rebuilt, the ornamentation can be replaced.

Posts and Piers- Decayed posts and piers should be rebuilt using a design which is not susceptible to moisture accumulation. If any of the posts show signs of decay, or if the wood is in direct contact with the ground, then new wood posts treated with a preservative should be installed on concrete piers. Wood posts that are exposed to the weather, as on rear porches or front stairs, should be separated from the concrete footing by an air space. Otherwise this is one of the most common places for dry rot to occur. Without the air space, water sits on the wood plate, working its way into the end grain of the post and rotting it. The construction detail for exterior wood posts and piers is more difficult and expensive to construct than its interior counterpart but the extra durability makes it worth the trouble and expense.

Stairs- Outside entry stairs receive constant use and abuse from pedestrians and the weather both. Although more durable materials like concrete and flagstone hold up best, they are often most inappropriate to the architectural style. When repairing steps, don't forget to check with the City's Building Division for the list of code requirements.

Wood Stairs- Deteriorated wood stairs are an extremely common problem on Victorian and colonial revival houses, yet it is imperative for the building's architectural integrity to continue the use of wood and not give in to the temptation of concrete.

The source of wood step problems is poor drainage. Even the smallest accumulation of rain can begin the rotting process. This may result from one or a combination of factors: solid boards installed perfectly flat; worn treads with a depression in the middle; lack of paint and caulk to provide a protective seal; or, adjacent features which pond water on the steps. Look for the symptoms of rot, as described in the section on wood porches.

When repairing wood steps:

- Consider turning worn treads over. A shallow depression switched to the reverse side will have no detrimental effect, and flipping the board will save money and time.
- Install new or recycled boards at a slight angle from front to back, about 1/2 -inch per tread.

- Design the railing so that the balusters are attached to a handrail on top and freestanding shoerail on the bottom. This allows a space for the water to run off the edge after a severe storm.
- Coat the treads with a wood sealer prior to installation.
- Make sure the tread nosing protects 3/4-inch to one 1/4-inch over the riser, to keep the joint water-free, and to afford a shadow that is a definite design asset.
- Do not direct drainage water onto the sill plate underneath the steps.

Brick Stairs- Brick is typically found on Craftsman Bungalows.

One problem encountered with brick stairs is settlement due to shifting soil support. To correct this, concrete must be injected beneath the existing structure and additional bracing may be required. This difficult operation should be executed by a qualified contractor.

Brick stairs are subject to cracked mortar joints. These require immediate attention in order to prevent water penetration which cracks and rots the mortar further.

Concrete Stairs- Concrete stairs are commonly found on prairie schoolhouses and California Bungalows. Shorter ones, often only a step or two are typical of the Period Revival style and Minimalist Traditional style. Occasionally, concrete steps

are embellished with redwood strips, mosaics, or tiles. Mediterranean and provincial houses are known for their shiny, red, painted concrete steps and matching walks. Green and grey are popular paint colors for the bungalow steps. It's valuable to stick with the popular colors because repetition lends visual unity to the neighborhood.

Another design aspect for concrete steps are the grooves. They may be geometric or abstract patterns or parallel line for skid proof purposes. The arrangement of grooves should be perpetuated if the concrete is repaired, or reinstated if the stairs are replaced.

Concrete steps are subject to spalling, the chipping off of small pieces from the nose of the tread. This is repaired by using a high strength mortar to bond new concrete to the old. If the damage is severe, consider adding a steel angle plate with an anti-slip surface.

13.7.4 Windows

Window Glass Repair - Many wood windows can be repaired by simple methods or replacement of wood pieces or glass. A broken pane of glass is replaced by first removing the existing putty from the window. Sometimes a soldering iron or torch is necessary to heat the old putty to make it easier to remove. After removing the old putty, remove the glazing points (small pins). The wood should then be sanded smooth and painted with a primer to seal it.

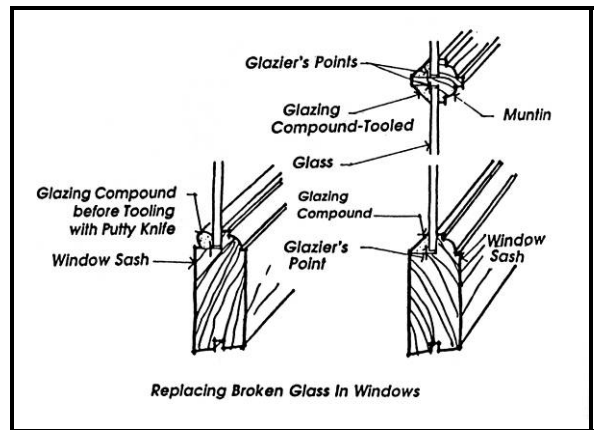

Figure 13-35: Example of broken glass replacement

The new pane of glass should be cut about one-eighth inch smaller than the opening (all sides of the pane should be measured because the opening is usually not shaped or "plumb"). Apply new glazing compound, place the glass firmly and secure with glazing points located about six inches apart.

Use first-quality putty compound, shaped into lengths about three-eighths inch in diameter and press it along the edge of the glass. Use a putty knife to form a smooth, angled finish. Follow the manufacturer's recommendation regarding drying time for the putty before painting. It should be noted that old glass usually has slight irregularities in its thickness (waves) and small air bubbles (seeds). Since the new glass will lack these imperfections, a pane of glass that is replaced adjacent to older panes may be noticeable. If this occurs in a particularly prominent location (e.g. front entry door) consideration might be given to obtaining an old piece of glass from a salvage yard or purchase

new restoration glass available at glass shops (Refer to Figure 13-35).

Repair small holes in wood members by cleaning away all loose debris and filling with a good quality putty. After drying according to the manufacturer's instructions, sand the surface, prime and paint.

Double Hung Window Repair - Double hung windows have two sashes - an outside sash that slides down and a lower, inside sash that slides up. The sliding movement of the window is controlled by weights connected to the window by cords that run over pulleys. Aside from actual broken or rotted sash pieces, the most common problems with these windows are broken sash cords, fouled pulleys and sticking due to warping or over painting.

Sticking can usually be eliminated by gently taping the frame of the window just enough to jar loose paint or debris, then opening the window. Cleaning the jambs, then lubricating with paraffin will often make the window operational. Light sanding may be necessary in order to smooth any rough areas where the window slides.

If severe warping has occurred, the window sashes will have to be removed and planed. An experienced carpenter would best complete this, as well as any problems with the cords or weights, as this work requires the removal of the window from its frame.

13.7.5 Doors

Door Repair - Typical problems with doors include sticking, not closing properly or having gaps around the door when it is closed. The first thing to check is the hardware composed of the hinges and strike plates of the door. These can often become loosened over time and the remedy is as simple as tightening a few screws. If any of these items need replacement, they should be replaced to match the original as closely as possible.

Lock and latch mechanisms may need simple tightening of the screws also, but a qualified contractor or locksmith should conduct more major repairs.

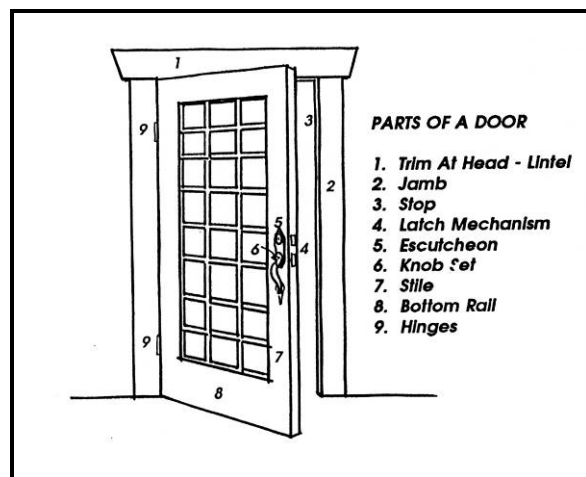

Figure 13-36: Illustration of door components

Replacement door hardware should closely match the original. If new matching hardware is not available, check for salvage hardware. The following information will be necessary to secure properly matching hardware:

- Diameter of the lock
- Size and location of the latch bolt holes
- Dimensions of the latch face plate
- Door thickness
- Back set measurement from the door's edge to lock hole center
- Type of lock being replaced
- Brand name of existing lock

13.7.6 Ornamentation & Trim

When repairing or replacing decorative trim work the following should be considered:

- Loose trim or ornaments should be reattached with galvanized finish nails or brass wood screws. Countersink nail screw heads and conceal nails with putty before painting. If the material must be removed to be repaired or copied, inspect the attachment carefully prior to any work. It is often a good idea to label pieces according to their original locations in order to replace them exactly.
- Wood ornamentation and trim should never be roughly hammered or pried loose. Determine how the piece is attached and carefully plan the work to be sensitive to the material and its weaknesses. Any prying action should be slow and careful, with a minimal amount of force. The prying bar or hammer should rest against a thin piece of wood to alleviate

damage to the adjoining surfaces.

- Many carved and detailed pieces of ornamentation can lose their detail by the continuous application of paint. Careful removal of the paint by heat gun or chemicals will revive the original detail. Never use abrasives on delicate ornamentation and never sandblast ornamentation or trim to remove accumulated paint, as this will destroy subtle details.
- An experienced painting contractor sensitive to historic houses is the most likely to preserve ornamental detail properly.
- If the trim or ornamentation is comprised of several layers of materials, it is helpful to sketch the components as they come apart to ensure proper reassembly. Broken pieces can usually be repaired with a good wood glue and gently securing the pieces together with a clamp or band. If the pieces are beyond repair, a skilled finish carpenter can duplicate the original work.
- When historic construction materials cannot be replaced or matched, care should be taken to match the original pattern, thickness, color, and texture as closely as possible with available materials. In general, simulated

replacement materials (artificial stone) are discouraged.

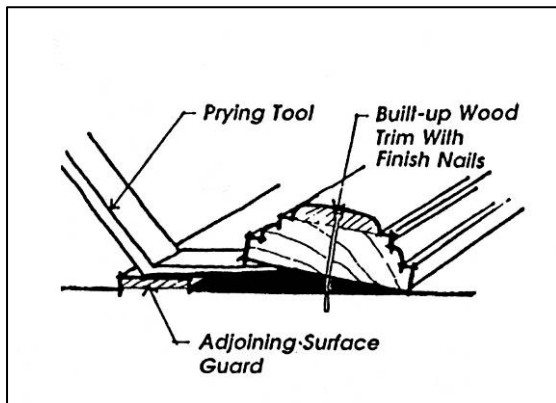

Figure 13-37: Proper repair of wood trim

Replacement of trim and ornamentation should occur just as carefully as the removal. Pieces should be caulked where water infiltration might occur.

13.7.7 Roofs

Roof leaks should be quickly identified and repaired to eliminate the destructive abilities of water at inside surfaces, as well as to structural members. Leaks occur at two general areas: where there are leaks in the roofing material itself; or where the roof intersects with another component, such as a wall or chimney. An active leak may be very frustrating to trace because the water level may travel prior to becoming noticeable. The wet spot in the ceiling is rarely directly below the actual leak

in the roof. The inspection for the leak should take place in the attic of the house, starting at the location of the wet ceiling.

To check for leaks in dry weather, look for telltale signs:

- Light shining through to the inside where there are worn or missing shingles
- Dark stains or discolorations on the underside of rafters or shingles
- Loose, rusting, or deterioration on flashing around joints and chimneys
- Sagging or distressed rafters
- Protruding nails
- Peeling paint on eaves and cornices

To check for leaks in wet weather:

- Find the area of wet ceiling in the attic
- Look to see if the water is coming from the rafters or the sheathing
- If the water drips from a rafter, follow it to the source (usually the ridge)
- Mark the bottom of the leak
- Temporarily caulk the hole with roofing caulk for wet weather use

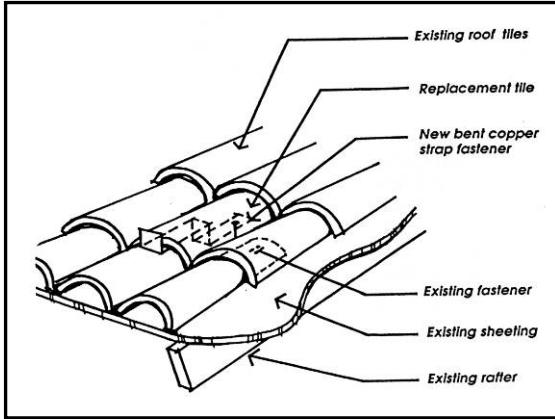

Figure 13-38: Example of roof repair for tile materials

13.8 ADDITIONS AND NEW ACCESSORY BUILDINGS

Opportunities for building expansion and addition exist among properties listed on the Register and within the Historic Districts. Additions to designated buildings may be necessary or desirable to ensure their continued use. Such additions are often the most sensitive and difficult design issues to manage. The following guidelines present some basic guidance to utilize when additions, including second stories, accessory structures (e.g. new entrances, garages, carports) or second dwelling units are contemplated.

13.8.1 General Principles

Additions should be designed so that if the addition were to be removed in the future, the essential form and integrity of the original structure would be unimpaired.

When designing an addition, the following principles should apply:

- a. Preserve significant historic and architectural features, details, and materials of existing building.
- b. Preserve the character and scale of the structure by maintaining existing proportions for the new addition.
- c. Avoid creating a faux historical look.

- d. Design new additions in a manner that makes clear what is historic and what is new.

13.8.2 Site Plan Considerations

- a. Additions should be carefully placed to minimize changes in the historic appearance of the building from the street (*Refer to Figure 13-39a & 13-39b*).
- b. Additions should be placed to the side or rear of the property and should minimize use of the street facing facades.

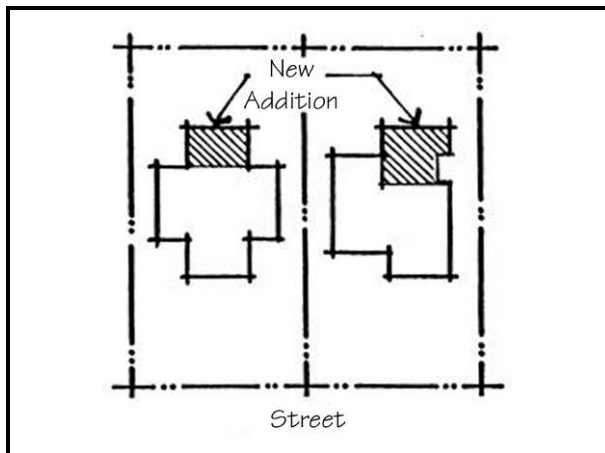

Figure 13-39a: Example of appropriate placement of new addition

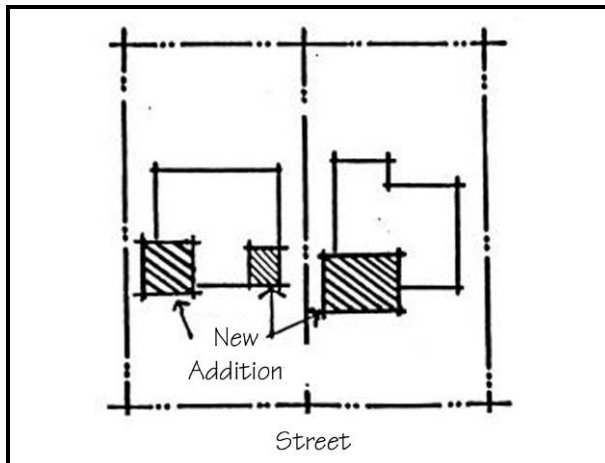

Figure 13-39b: Example of inappropriate placement of additions

13.8.3 Architectural Compatibility



Example of a Craftsman Bungalow home

- a. The design of a proposed addition should complement the overall scale, proportion, massing and detailing of the original structure and should not destroy historically significant features, materials or finishes.
- b. Additions that may alter the facade of the building need to be considered carefully. Additions to architecturally significant buildings need to complement distinctive design features such as:
 - Building scale, massing and proportion;
 - Exterior materials;
 - Roof style, pitch, material;
 - Finished floor height;
 - Color; and,
 - Window rhythm, size, shape and type.
- c. Avoiding a “faux” historical appearance, new additions may also incorporate architectural details compatible with, but not necessarily identical to, the historic structure, including:

- Exterior material pattern
- Window rhythm, size, shape, and type;
- Trim and decoration;
- Foundation wall detailing.

Refer to **Appendix A** for a discussion on the character defining features of specific styles of architecture to ensure compatibility of design.

13.8.4 Scale and Mass

Each building has a characteristic scale and mass that is unique to its particular style. For example, Victorian era homes, such as Italianate, Stick and Queen Anne are usually thought of as being rather tall and slender with steep roofs, asymmetrical shapes, fine details and varied textures. In contrast, the Craftsman Bungalow style emphasizes horizontal lines giving them a low to the ground appearance. Low-pitched roofs with wide and thick porch pillars all add to this appearance.

Each style of architecture in Santa Ana possesses unique qualities that help to establish its own individual mass and scale. It is important to recognize these features and incorporate and continue them in additions and expansions.



Figure 13-40: Additions should match scale and mass of existing building

13.8.5 Roof Pitch Consistency

The roof of a building, especially its style and pitch, is an important architectural element that must be taken into consideration when planning an addition or accessory building.

- a. The roof style, pitch and detailing on the addition should match the original building (*Refer to Figure 13-40*).
- b. Roof materials should also match as close as possible in order to maintain the architectural *style* of the original building.

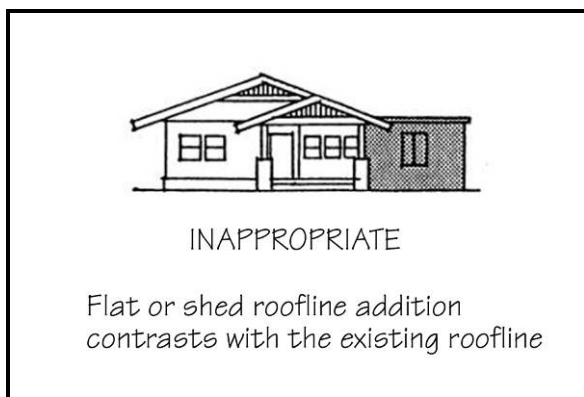

Figure 13-41: Roof additions should match in type and slope

13.8.6 Second Story Additions

- a. Adding a second story to an existing building will change a building's proportions and should be carefully designed to follow similar two story examples of the particular style.
- b. Integrating the new second story addition into the original design of the building is more compatible to the structure and respectful of the streetscape if the addition is setback from the front facade (*Refer to Figure 13-40 and 13-42*).
- c. New additions should be designed to respect and not overpower the significant architectural features such as chimneys, porches, etc.

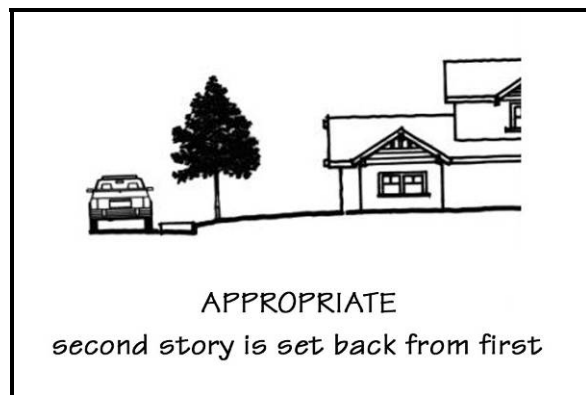

Figure 13-42: Second story additions should be respectful of the existing streetscape

13.8.7 Exterior Materials

- a. The exterior appearance of additions and new accessory buildings should be compatible with the style, quality, dimension, texture, and color of materials on the existing building.
- b. Care should be taken at the intersections of the new and the old to avoid awkward connections of the horizontal lines.
- c. When new additions introduce major architectural features (e.g. chimneys, porches, etc.), they should be compatible with the historic style, quality, dimension, texture, and color of materials on the existing building.

13.8.8 Doors

- a. The exterior doors of a historic building are indicative of its architectural style as previously described. Additions should incorporate doors compatible with the style of the house, especially if they are visible from the street.

13.8.9 Windows

- a. Original window type, style, and material should be integrated when creating an addition. Most often, windows in historic buildings were wood sash.

- b. The general rhythm of window placement (pattern of solid to void) and the size of the windows should complement the style of the house, but need not match exactly.



Figure 13-43: Example of window rhythm

- c. Exterior trim of new windows should be compatible in design and color with windows on existing structure.

13.8.10 Accessory Structures and Detached Second Dwelling Units

- a. A new (or existing) accessory structure, such as a garage or garden shed, or a second dwelling unit can generally attain architectural compatibility by incorporating a few key character-defining elements of the main building. Some of the key elements to consider include:
 - Roof pitch, style and material;
 - Building proportions;
 - Exterior materials;
 - Door and window style and placement pattern;
 - Color

- b. Accessory buildings are generally utilitarian structures and need not attempt to incorporate the level of detail as the house unless they are attached to it, are clearly visible from the street, or are part of a formal historic designation.
- c. Whenever possible, locate accessory buildings and detached second dwelling units out of view from the street.

13.9 LANDSCAPING

Landscaping and yards can be part of the historic context and in some cases, may be part of the historical designation. The guidelines in this section are intended to assist an owner determine what type of landscaping might be most appropriate for an historic building. In addition to site specific information that you will need to consider (i.e. sun exposure, drainage, soil, view, etc.) you will want to consider some factors before you begin.



- What are the visual characteristics of your neighborhood?
- Are there prevailing landscape styles in the neighborhood?

- What is the relation of your house to the street?
- Are many fences used on your street? What kind?
- Is a formal or informal design desired?

13.9.1 General Landscape Guidelines

- a. Strive for some semblance of unity in the landscape, rather than disjointed groupings and scattering of features. No one element should stand out; instead, all the parts – plants, gradients, and structures should work together harmoniously.
- b. Balance the landscape using mass, color, or form to create equal visual weight on either side of a center of interest. An example of balance would be creating mirror images of shrubs on each side of a stairway or balancing a large tree on one side of the house with a grouping of smaller trees on the other side.
- c. Landscaping should be in scale and proportion with adjacent buildings and other landscaping elements and should be of appropriate size at maturity.
- d. Avoid a monotonous landscape by selecting plants in a variety of shapes, shades, and textures.
- e. Existing mature, healthy trees should be preserved and incorporated within the overall landscaping plan of the project.

13.9.2 Landscaping Design Themes

Different architectural styles are generally associated with “formal” or “informal” landscape design theme.

a. *Formal* designs emphasize a uniform balance of landscape features with a mirror-like symmetry. Landscaped areas are plotted out in geometrical shapes; trees and shrubs may be trimmed into stylized forms. This style is often best suited for Victorian styles such as Queen Anne, Stick, Italianate, Spanish Colonial/Mediterranean Colonial Revival, and Art Moderne (Refer to Figure 13-46a & b).



Figure 13-46a: Example of formal landscape



Figure 13-46b: Example of formal landscape

b. The informal landscape theme emphasizes asymmetrical designs, preferring arrangements that appear more natural and free flowing. The informal design approach is most suited for Tudor, Prairie, Craftsman, and California Bungalow, which represent a rejection of formality and promote a return to nature (Refer to Figure 13-47a&b).



Figure 13-47a: Example of informal landscape



Figure 13-47b: Example of informal landscape

13.9.3 Fences

Fences of appropriate materials and design can do much to contribute to the historic flavor neighborhoods. The guidelines below are intended to

supplement the regulations identified in the City of Santa Ana’s Zoning Code. **Appendix B** describes fence types appropriate for many of the architectural styles existing in the City.

a. Fences should be designed to complement the architectural style and character of the main dwelling and the neighborhood. Generally speaking, fences of wood, stone/wood, iron, brick and stucco may be appropriate materials (*Refer to Figure 13-48*).



Figure 13-48: Craftsman-influenced fencing

b. Fences should be kept as low as possible while still performing their intended decorative or screening functions and must meet City code requirements.



Figure 13-49: Example of picket fencing at a Queen Anne

- c. The design of gates should match the fence pattern, design and materials.
- d. Front yard fences in an exaggerated design or with a fortressing look are inappropriate.



Figure 13-50: Example of inappropriate fence

13.9.4 Walkways

a. The main entry walkway to the house contributes to the overall character of the house. The materials listed below are most appropriate for walkways in residential districts, but must be compatible with the materials found on the structure:

- Brick
- Natural gray concrete – textured to expose fine aggregates
- Stone – random or cut patterns
- Cobble – gray granite or river rock
- Decomposed granite
- Poured-in-place or pre-cast natural gray concrete stepping stones
- Glazed non-slip ceramic tiles (accent only)
- Terra cotta tiles and pavers
- Painted concrete

- b. Original walkways, when present, should be preserved. Do not replace the entire walkway, when the repair or limited replacement is appropriate.
- c. When replacement is necessary, the new walkway should match the original in terms of color, texture and material and score pattern.



Figure 13-51: Brick walkway

- b. Considering the positive effect of a well-planned lighting system can add to the overall appearance of the house. Use style of lighting fixtures that complements the architectural style of the house.
- c. Avoid using tall fixtures that do not fit the pedestrian scale of the residential yard.
- d. Exterior lighting fixtures on an historic structure may be character-defining features. Avoid replacing them, when a repairing them would be appropriate.

13.10 RESIDENTIAL LIGHTING

The use of area and accent lighting can add to the aesthetic appeal of any house regardless of its architectural style. Lighting can also fulfill security needs when properly placed.

- a. Use only the amount of light required to effectively illuminate the area – more light is not automatically better. When exterior lighting is introduced, use lighting fixtures that shield the light from spilling over onto adjoining properties. Consult the Santa Ana Police Department for additional regulations.

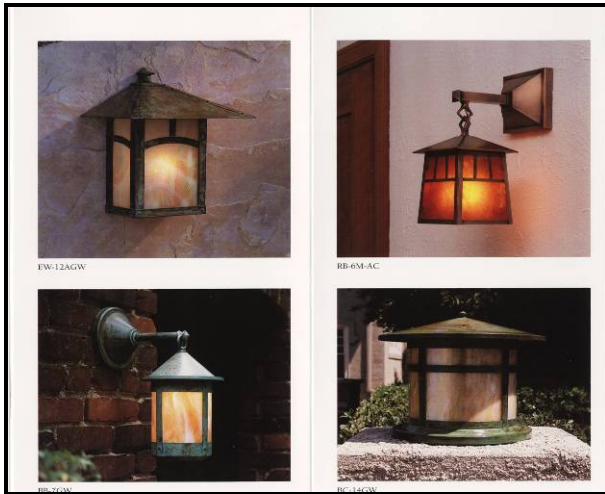

Figure 13-52a: Examples of Craftsman-influenced lighting



Figure 13-52b: Examples of various lighting styles

13.11 ADDITIONAL RESOURCES

To further assist preservation efforts and the development of appropriate infill development, the following Appendices are provided:

Appendix A: Santa Ana Architectural Styles

This Appendix provides an overview of architectural styles predominant in the community

Appendix B: Fence Design

This Appendix provides an overview of fence designs for most of the architectural styles predominant in the community

Appendix C: Secretary of The Interior’s Standards for Rehabilitation

This Appendix contains the full text of the Secretary of Interiors Standards for Rehabilitation of Historic Buildings.

Appendix D: Glossary of Architectural Terms

This Appendix provides a listing of commonly used architectural terms.

Appendix E: Incentives for Historic Properties

This Appendix provides an overview of currently available incentives for the preservation of historic properties.

Appendix F: Historic Precedents for Color

This Appendix provides an overview of the historic precedents for the use of exterior colors for various architectural styles.

Appendix G: Resources for Historic Preservation

This Appendix provides a listing of resources available.

Historic Structures Guidelines..... 1

13.1 Introduction..... 1

13.2 General Design Objectives..... 2

13.3 Applicability 2

13.4 Secretary of the Interior’s
Standards..... 3

13.5 Preservation Incentives..... 6

13.6 Historic Building Guidelines 6

13.7 Repair and Cleaning 22

13.8 Additions and New Accessory
Buildings..... 34

13.9 Landscaping 40

13.10 Residential Lighting 43

13.11 Additional Resources 44