

# Chapter 14

## Signage Guidelines

### 14.1 INTRODUCTION AND PURPOSE

This Chapter addresses signage for all development types within the City of Santa Ana. The signage design guidelines are intended to ensure quality signs that communicate their message in a clear fashion. These guidelines should be used in conjunction with the provision and standards contained within the City of Santa Municipal Code.

Applications for sign permits shall be filed with the City of Santa Ana Planning and Building Agency. This permit is reviewed concurrent with the building permit required for any sign, including window and painted signs.



*Figure 14-1: Signs add to and support the image of a City*

### 14.2 GENERAL DESIGN OBJECTIVES

Sign design for all projects in Santa Ana should:

- Encourage creative, well-designed signs that contribute positively to Santa Ana's visual environment, expression of local character, and development of a distinctive image;
- Recognize that some businesses are small, non-franchise establishments, that depend on their signs as the primary means of advertising and require the use of a variety sign types that are well designed; and,



*Figure 14-2: The use of quality and durable materials is encouraged*

- Be compatible with the building's architectural design and with other signs in the immediate vicinity.

### 14.3 GENERAL SIGN DESIGN GUIDELINES

This section provides general design guidance for all sign types. Project applicants should utilize these general guidelines in addition to the guidelines

for the particular sign type. The following guidelines apply to all signs:



Figure 14-3: Creative and well designed signs should be incorporated into all development types

- a. The location and size of signs on any building should be proportioned to the scale and relate to the architecture of that particular structure.
- b. Oversized and out-of-scale signs are inappropriate (Refer to Figure 14-4).



Figure 14-4: Oversized signs and signs that project above the roof area are strongly discouraged

- c. Sign colors and materials should be selected to contribute to the sign's legibility. Excessive use of colors is discouraged.

- d. Freestanding/Monument signs should be placed within landscaped area(s) perpendicular to approaching traffic and positioned to provide clear lines of sight at intersections and driveway approaches (Refer to Figure 14-5).

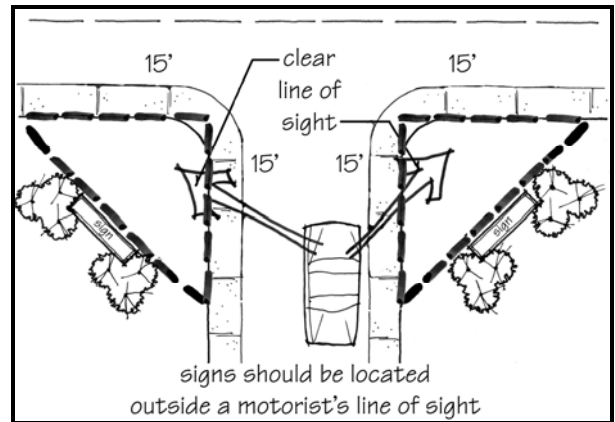


Figure 14-5: Signs should be located outside motorist's lines of sight

### 14.3.1 Placement

- a. Signs should not project above the edge of the rooflines.
- b. Signs used for business identification on the primary business frontage should be placed near the main business entrance in a location that does not cover doors, windows, or architectural details.

### 14.3.2 Materials

- a. Wooden Signs: There are several ways to effectively utilize wooden signs. A wooden wall sign can be routed, carved or sandblasted to get the effect of raised letters (Refer to Figure 14-6).

- b. Metal Signs: Applications of metal include: (1) applying raised letters on a metal band with the paint and lettering applied to the surface; (2) Use of galvanized or baked enamel finish to avoid rusting (*Refer to Figure 14-6*).
- d. The selected materials should contribute to the legibility of the sign. For example, glossy finishes are often difficult to read because of glare and reflections.
- e. Precast letters (e.g. molded plastic or brass) applied to a building surface also can be an effective signing alternative.



*Figure 14-6: Example of a sign that uses wood and metal in the design*

- c. Sign materials should be compatible with the building facade upon which they are placed.



*Figure 14-7: Painted signs are encouraged, but should not be painted over existing architectural elements, as shown in this example*

**14.3.3 Color**

- a. Colors should relate to and complement the materials or paint scheme of the buildings, including accenting highlights and trim colors. The number of colors on any sign should be limited to three. This heightens readability (visibility) especially when one color is a dark hue, the second a medium hue and the third a light accent color.
- b. Contrast is an important influence on the legibility of signs. Light letters on a dark background or dark letters on a light background are most legible
- c. Fluorescent colors should not be used.

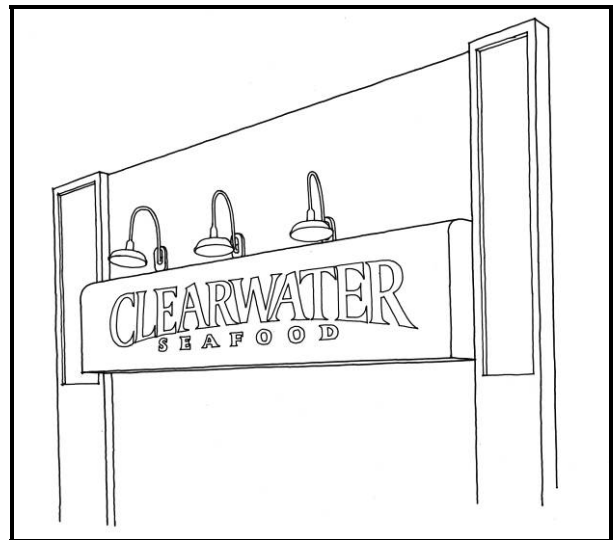
**14.3.4 Sign Legibility**

- a. An effective sign should be legible. The most significant influence on legibility is lettering style.



*Figure 14-8: Easy to read, simple typefaces and symbols are encouraged*

- b. Lettering styles used on signs should be highly legible. It is in the best interest of the business establishment that signage can be read clearly and is attractive to the passer-by (*Refer to Figures 14-8 and 14-9*).



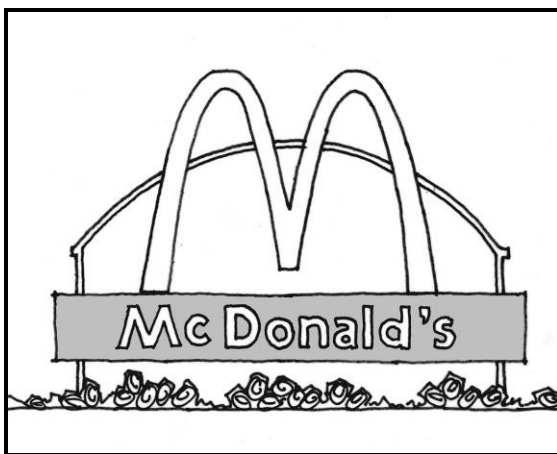
*Figure 14-9: Choose lettering styles that are legible. The use of appropriate lettering styles has the most significant impact on sign legibility.*

- c. Limit the number of lettering styles in order to increase legibility. A general rule to follow is to limit the number of different letter styles to no more than two for small signs and three for larger signs (*Refer to Figure 14-10*).
- d. Avoid spacing letters and words too close together. Crowding of letters, words or lines will make any sign more difficult to read. Conversely, over-spacing these elements causes the viewer to read each item individually, again obscuring the message.



*Figure 14-10: Limiting the number of lettering styles on a sign will ensure legibility.*

- e. Use symbols and logos in the place of words whenever appropriate. These images will usually register more quickly in the viewer's mind than a written message (*Refer to Figure 14-11*).
- f. When utilizing trademarks, applicants should submit proof of trademark registration prior to sign approval.
- g. The design of logos and signs should be complementary to the architecture of the building.



*Figure 14-11: The use of symbols and logos are encouraged*

**14.3.5 Sign Illumination**

- a. Signs should have the capacity of being lit externally for evening visibility.
- b. Individually illuminated letters, either internally illuminated or back lighted solid letters (reverse channel), are a preferred alternative to internally illuminated signs. Avoid illuminating an entire sign (Refer to Figure 14-12).



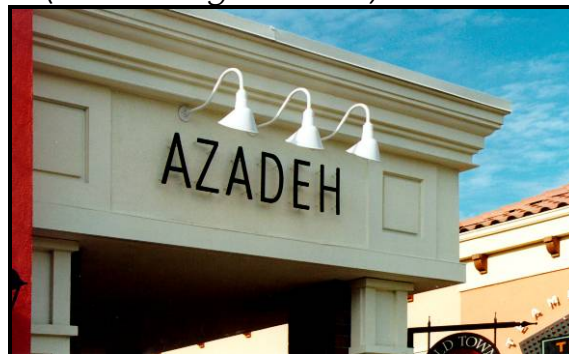
*Figure 14-12: Internally illuminated signs should be avoided. Only the sign copy should be illuminated*



*Figure 14-13: Backlighting of signs is encouraged*

- c. Indirect external lighting of signs is strongly encouraged within historic districts.
- d. Indirect external illumination should be placed so that it complements

the surface the sign is attached to (Refer to Figure 14-14).



*Figure 14-14: Choose light fixtures that are compatible with the facade they are attached to.*

- e. Whenever external lighting fixtures are used, care should be taken to properly shield the light source to prevent glare from spilling over into residential areas and any public right-of-way.

**14.4 GUIDELINES FOR SIGN TYPES**

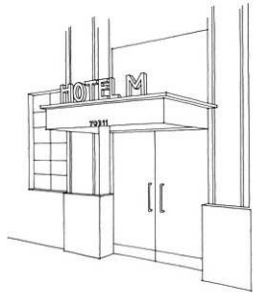
There are a variety of sign types permitted within the City of Santa Ana. Signs may vary in features such as size, location, material and color. When considering signage for a project, applicants should first consult with applicable sections of the Santa Ana Municipal Code. The guidelines contained in this section should be used to supplement Municipal Code requirements. *Figure 14-15: Sign Examples* provides graphic representations of various sign types permitted by the City of Santa Ana.

**14.4.1 Wall Signs**

Wall signs are attached parallel to or painted on a wall surface, including a parapet or canopy fascia of a

building (refer also to Section 14.7 for canopy signs). The following guidelines apply to wall signs:

- a. Wall signs should be applied horizontally directly above the storefront (*Refer to Figure 14-19*).
- b. When a building contains two or more businesses, wall signs should complement one another in color and shape and be located in the same position over the storefronts (*Refer to Figure 14-18*).



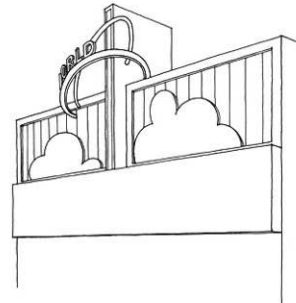
marquee sign



monument sign



projecting sign



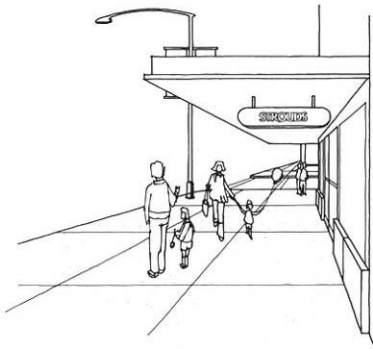
roof sign



special event/display sign



temporary sign

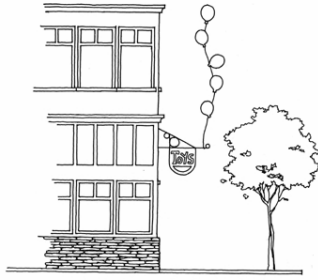


under canopy

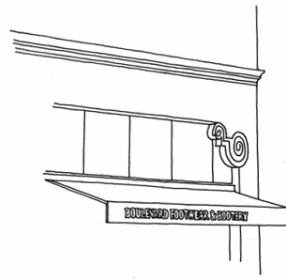


wall sign





aerial sign



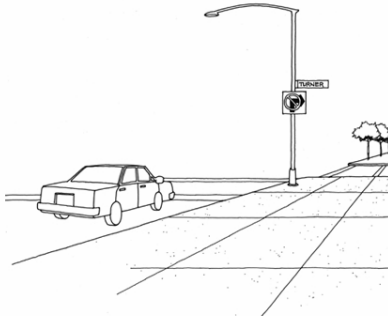
awning sign



canopy sign



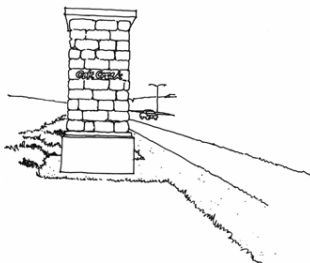
changeable copy sign



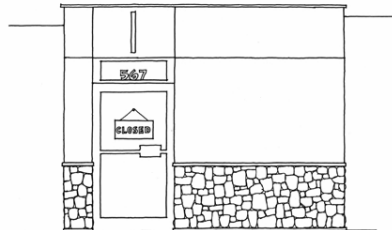
directional sign



flag canopy sign

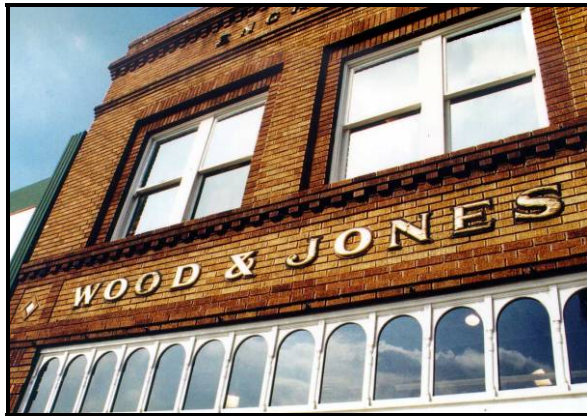


freestanding



incidental sign

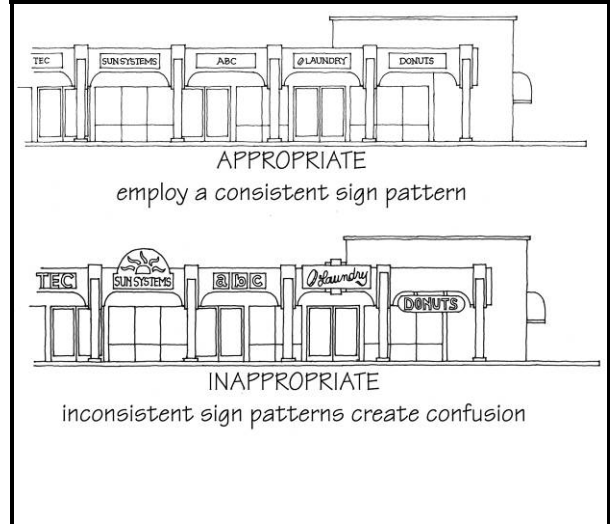
A wall sign should be located where architectural features or details suggest a location, size or shape for the sign. The best location for a wall sign is generally a band or blank area between the first and second floors of a building (Refer to Figure 14-16).



*Example 14-16: Signs should be located where architectural details suggest a location*

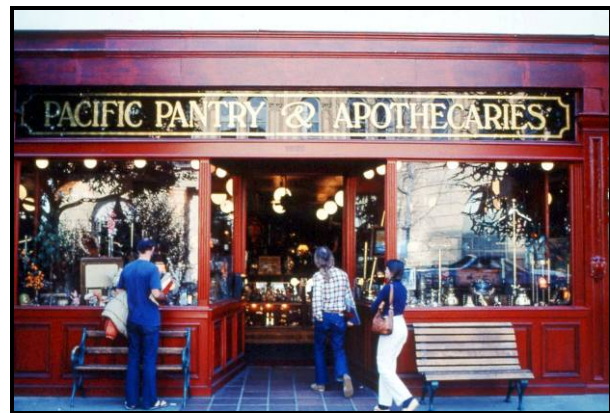


*Figure 14-17: Wall signs in a shopping center should be consistently placed in the same location*



*Figure 14-18: Employ a consistent sign pattern*

- c. Wall signs should be centered above the store or building entrance within an architecturally established area or unbroken area of the building facade.

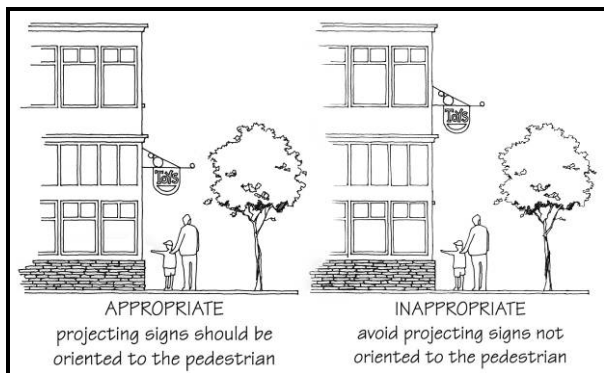


*Figure 14-19: Place wall signs centered above building entrances*

#### 14.4.2 Projecting Signs

Projecting signs are permanently attached to building, perpendicular to the surface of a wall or projection. The following guidelines apply to projecting signs:

- a. Projecting signs of a small scale are typical of pedestrian-oriented commercial areas. These signs are effective if oriented and scaled to the pedestrian (*Refer to Figure 14-21*).
- b. The sign's location should be determined by visibility and should be no higher than the first level of a building.



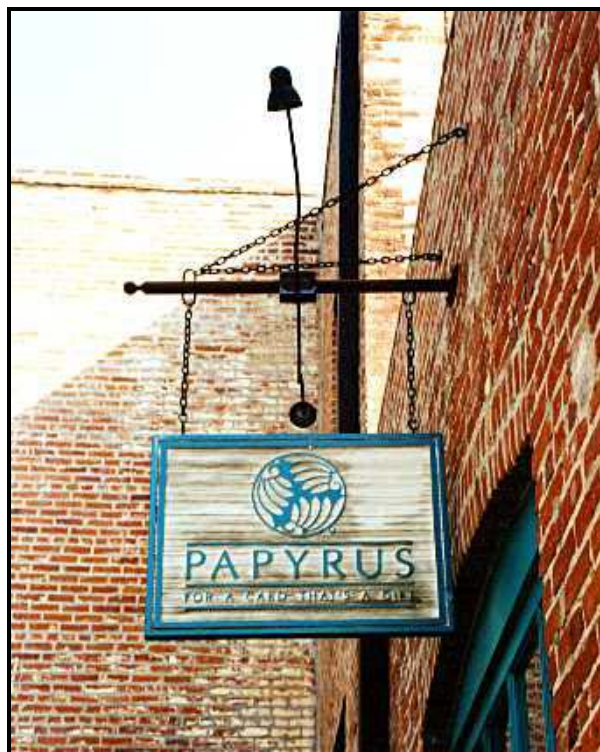
**Figure 14-20: Projecting signs should be placed as low as possible for easy visibility.**

- c. A projecting sign should never be located lower than eight feet above ground level or extend closer than two feet to the nearest curb.
- d. The sign should be hung at a 90-degree angle from the face of the building, except as part of a creative sign.



**Figure 14-21: Projecting signs should be placed at a 90-degree angle from the face of the building.**

- e. Internal illumination of a projecting sign should be avoided. Projecting signs are encouraged to be externally illuminated.



**Figure 14-22: External illumination of projecting signs is encouraged**



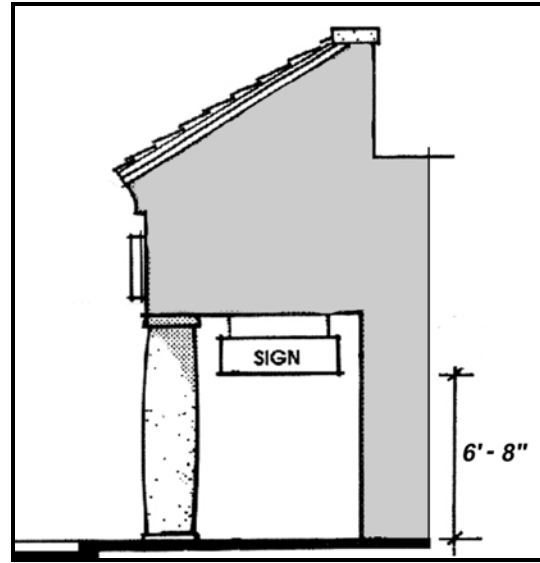
*Figure 14-23: Sign supports and brackets should be compatible with the design and scale of the sign*

- f. Projecting signs should be constructed of metal or wood. Plastic projecting signs are strongly discouraged.
- g. Sign supports and other hardware should complement the design and scale of the projecting sign (Refer to Figure 14-23).

### **14.4.3 Under-Canopy Signs**

Under-canopy signs are suspended below a canopy or marquee, perpendicular to the nearest elevation. The following guidelines apply to under-canopy signs:

- a. Under canopy signs should be constructed largely of wood. Under-canopy signs could also be constructed of tile and metal with an enamel design. The choice of materials should be weather resistant.
- b. Under canopy signs should never hang lower than 6 feet 8 inches from the ground (Refer to Figure 14-24).



*Figure 14-24: Under-canopy signs should not hang lower than 6 feet 8 inches above pedestrian walkways.*



Figure 14-25: Example of an under-canopy sign

#### 14.4.4 Window Signs

Window signs are located within a window area of a business. Window signs may consist of permanent materials affixed to a window, or text and graphics painted directly onto the window surface. The following guidelines apply to window signs:

- a. Window signs should not exceed 25 percent of the window area, and only one window sign per frontage is allowed (Refer to Figure 14-26).

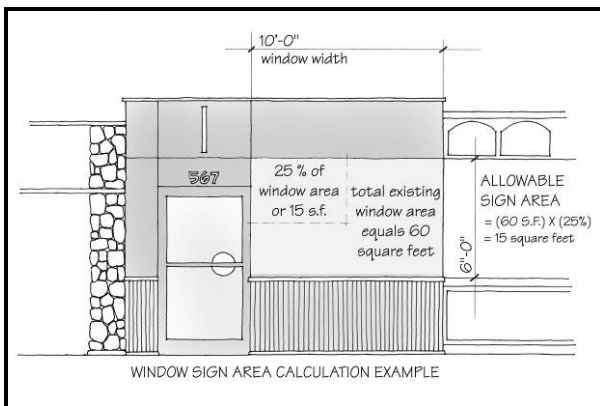


Figure 14-26: Example of calculating window sign area.

- b. Window signs should be applied so that they do not obscure the visibility into a shop for the passerby. Every effort should be made to integrate window signs with store window displays (Refer to Figure 14-27).



Figure 14-27: Avoid window signs that cover entire window area

- c. Lighted signs, flashing signs or any other sign not applied directly to a windowpane are not permitted (Refer to Figure 14-28).



Figure 14-28: Lighted signs placed on a window are not allowed

- d. Window signs should be limited to individual letters placed on the interior surface of the window and

intended to be viewed from outside.

- e. The text or sign copy of a window sign should be limited to the business name and brief messages (Refer to Figure 14-29).



Figure 14-29: Window signs should be limited to the business name and brief messages

**14.4.5 Awning, Canopy, and Marquee Signs**

Awning signs are affixed to or imprinted on a temporary shelter composed of non-rigid material on a supporting framework. Awning signs are affixed to the exterior wall of a building. Canopy signs are affixed to any permanent architectural projection extending over a door, entrance, window, or outdoor serve area. Marquee signs are affixed to a permanent projection extending from the building or beyond the wall of a building.

- a. Only permanent signs that are an integral part of the awning or canopy are allowed.

- b. Lighting directed downwards that does not illuminates awning signs is allowed.

- c. Awning signs should not be internally illuminated.



Figure 14-30: Awnings should be externally illuminated

**14.4.6 Freestanding and Monument Signs**

Freestanding signs are signs that stand directly on the ground and are independent from any building or structure. Monument signs are freestanding low-profile signs where the sign width is greater than the sign height. Monument signs should have a solid background.

- a. Freestanding and Monument signs should be located where they are not obstructed by landscaping and can be easily viewed by pedestrians and motorists.
- b. Freestanding and Monument signs are required to be located in a landscaped planter away from a driveway or other vehicle access point (Refer to Figure 14-31).

- c. Freestanding and monument signs should be placed perpendicular to the street (Refer to Figure 14-33).

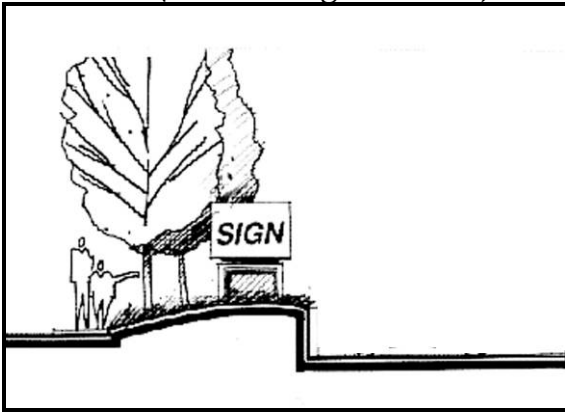


Figure 14-31: Location of any freestanding or monument signs should be setback from the public right-of-way



Figure 14-32: Freestanding/monument signs must be surrounded by landscaping

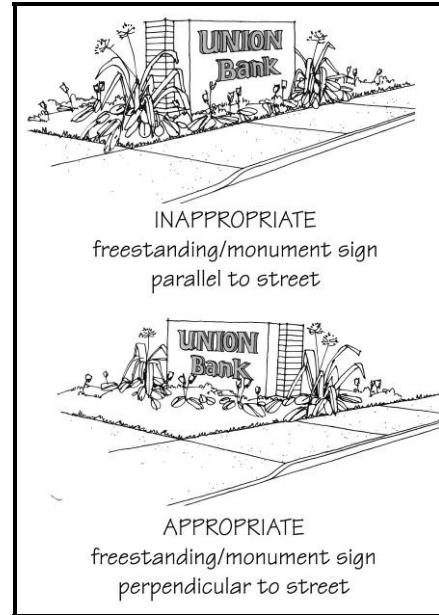


Figure 14-33: Freestanding/monument signs should be placed perpendicular to the street.

- d. Freestanding and monument signs should be on ground (Refer to Figure 14-34).

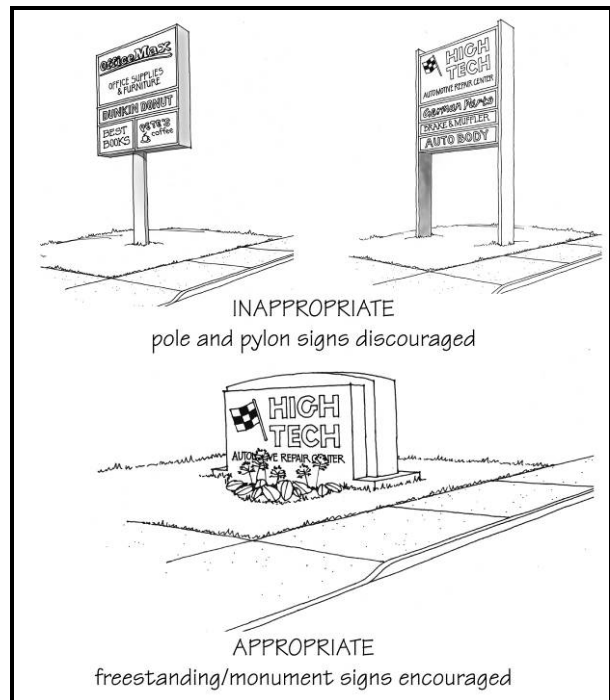


Figure 14-34: Freestanding/monument signs should be used instead of pole or pylon signs.

- e. Signs should provide solid architectural bases and are

encouraged to match the architectural elements of the development it serves (Refer to Figure 14-35).



Figure 14-35: A solid base is encouraged on all freestanding/monument signs



Figure 14-36: Avoid freestanding/monument signs having no more than 8 items.

windows are highly inappropriate and should never be used.



Figure 14-37: Examples of temporary signs at a storefront location

## 14.5 MISCELLANEOUS SIGNS

### 14.5.1 Temporary Signs

Temporary signs are utilized temporarily and are not permanently mounted or attached to a building or structure.

- a. Temporary signs such as hastily hand painted "sale" signs printed on coarse paper and plastered in



**14.5.2 Street Address Numbers**

Number graphics can be effectively designed and used to highlight the store’s address and location. This is especially effective when there is more than one shop per building. Addressing should be consistent from store to store on a multi-tenant building.



*Figure 14-38: Sign that highlights the building’s address*

**14.5.3 Parking Lot and Directional Signs**

Parking area signs, other than those required by law or other ordinances such as a “HANDICAPPED PARKING ONLY” sign, are not permitted.



*Figure 14-39: Example of a directional sign*

**14.5.4 Vehicle Signs**

Vehicle Signs (other than contractor name and number and other similar car or truck door signs), portable A-frame signs, balloons, flags and animate or inanimate representational figures such as animals or statues are strictly prohibited.

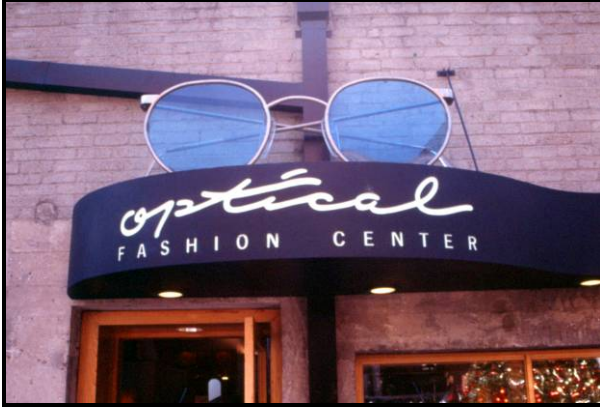


*Figure 14-40: Vehicle Signs are not allowed*

**14.5.5 Mimetic Signs**

Mimetic signs are signs that utilize elements that imitate or represent a product, or service. The following guideline apply to mimetic signs:

- a. Signs that advertise a business through the use of graphic or crafted symbols, such as shoes, keys, sun glasses, books, etc. are strongly encouraged (*Refer to Figure 14-41*).



*Figure 14-41: Example of a mimetic sign*

- b. A mimetic sign that has only the symbol or image should convey very clearly those services that are offered or products that are sold inside the establishment.
- c. The business' name may accompany a mimetic sign.
- d. Letters, colors and design shall be the same as for a wall sign.



*Figure 14-42: Use of crafted symbols is encouraged*