

17 GABLE END AT SPANISH SCALE: 1"=1'-0"

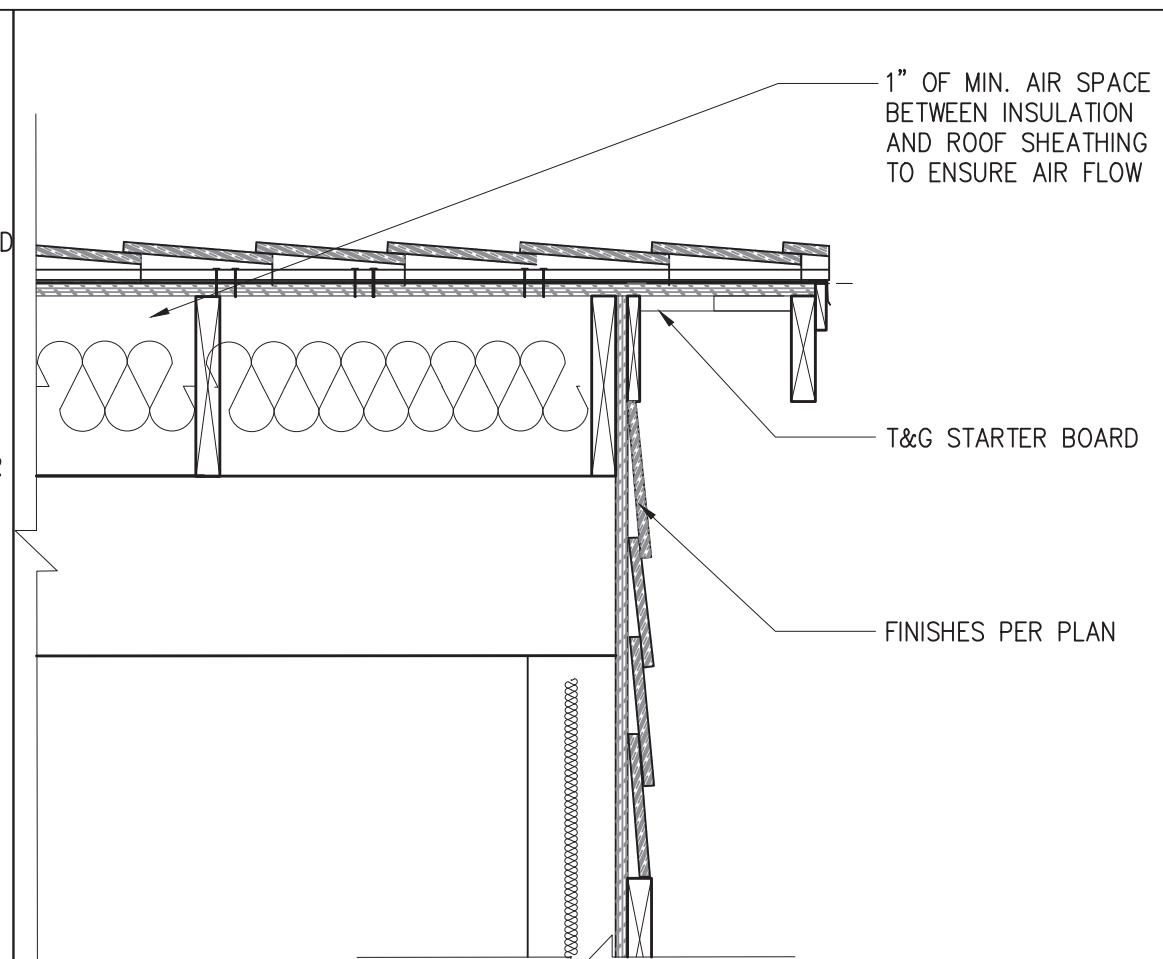

13 GABLE END AT RANCH & TRADITIONAL SCALE: 1"=1'-0"

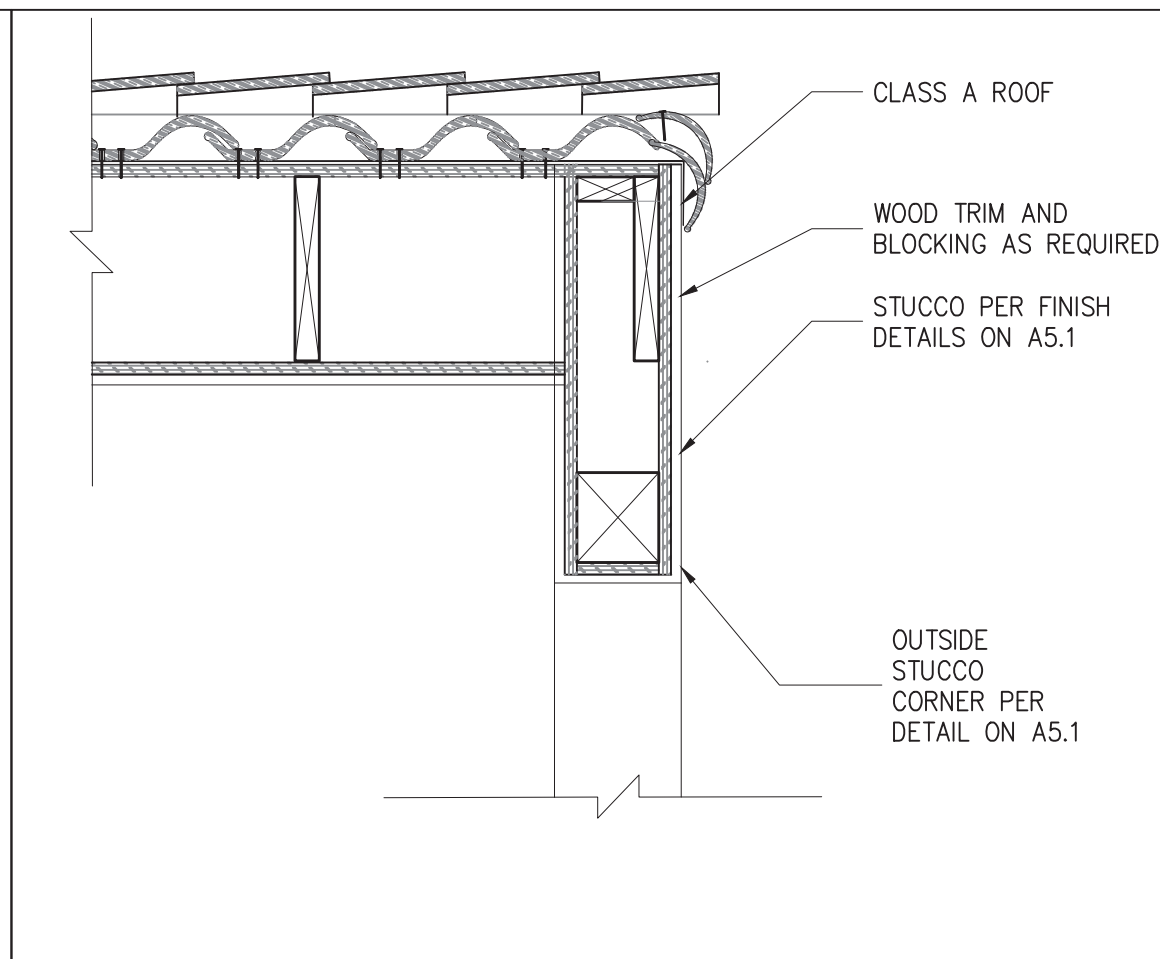

9 GABLE AT SPANISH PORCH SCALE: 1"=1'-0"

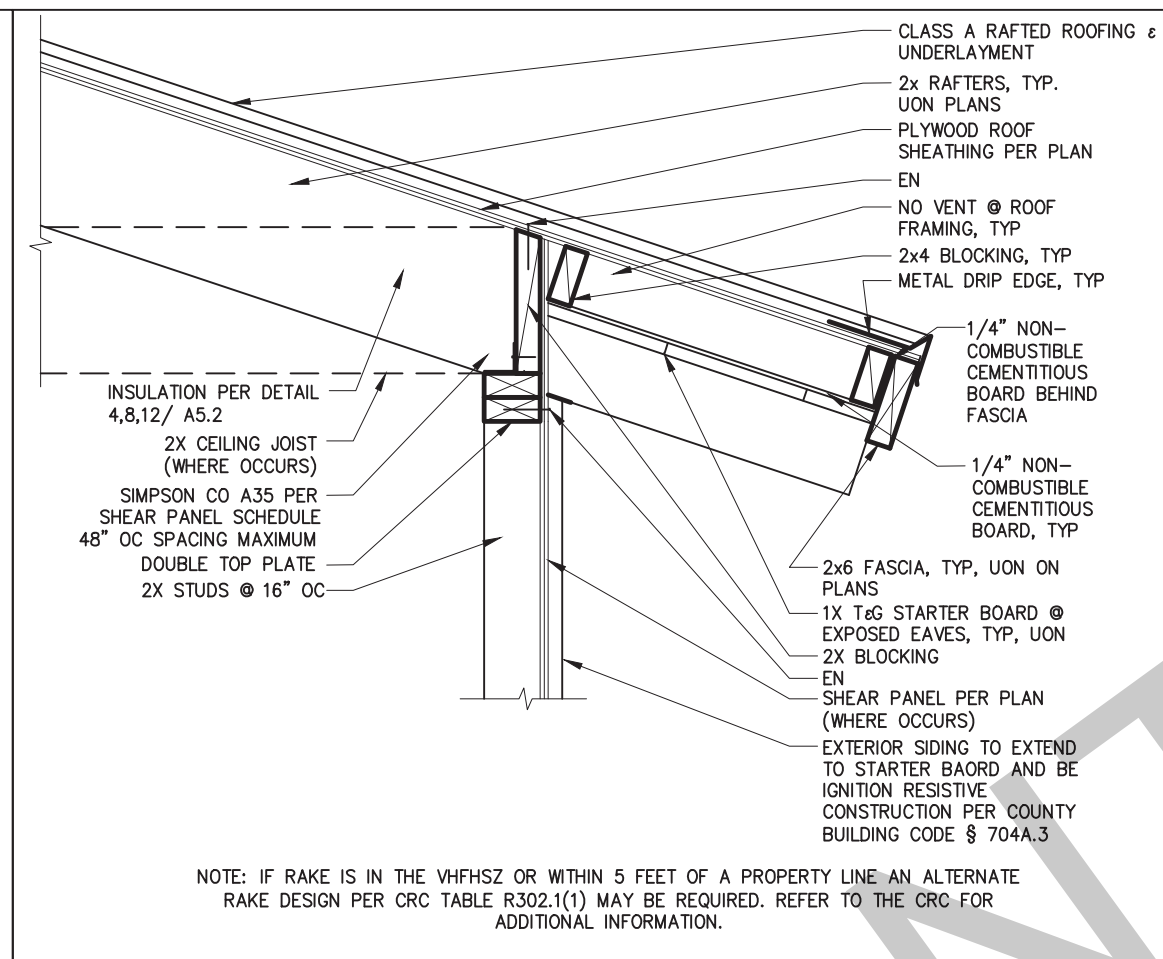

5 IGNITION RESISTIVE EXPOSED RAFTER EAVE SCALE: 1"=1'-0"

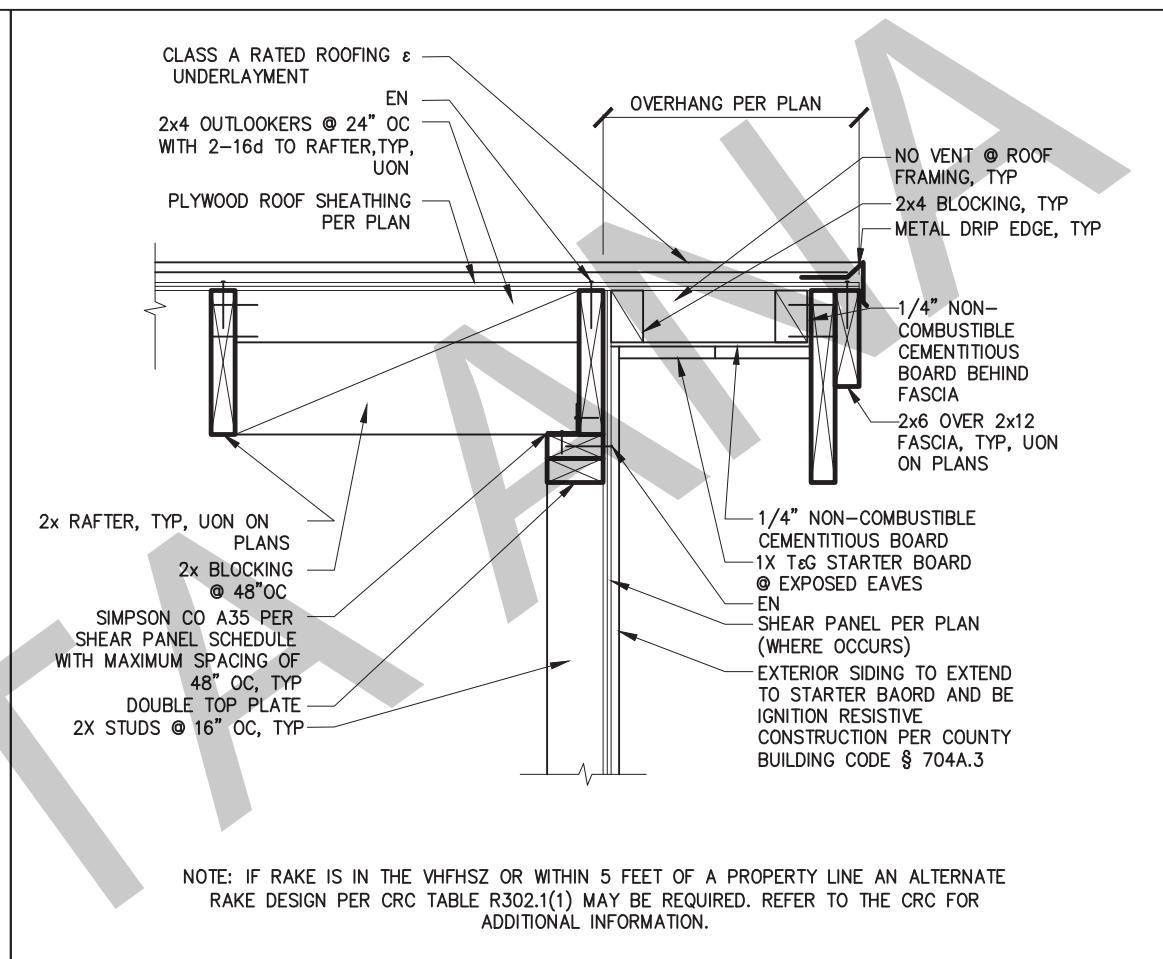

1 IGNITION RESISTIVE GABLE WITH 2x6 & 2x12 FASCIA SCALE: 1"=1'-0"

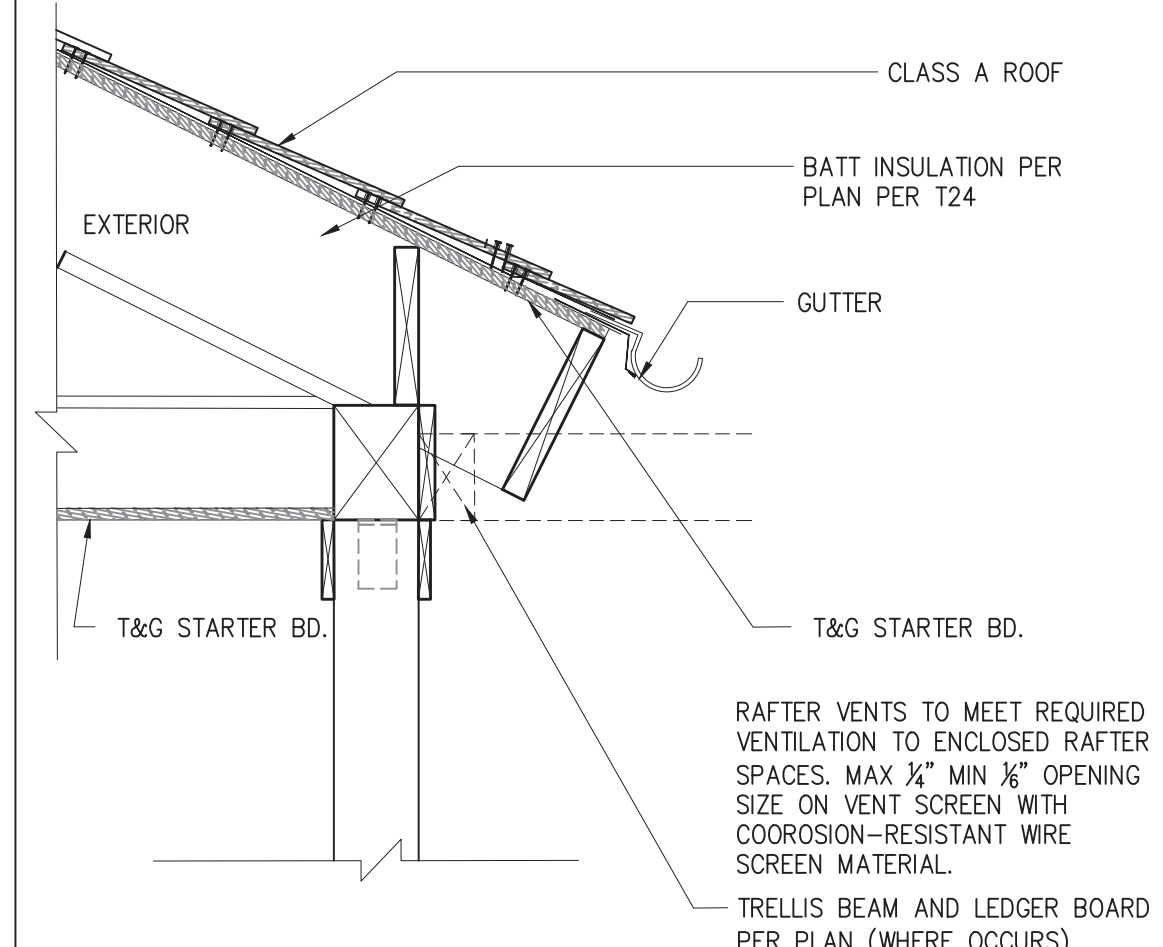

18 EAVE AT TRADITIONAL PORCH SCALE: 1"=1'-0"



10 RAFTER EAVE DETAIL SCALE: 1"=1'-0"

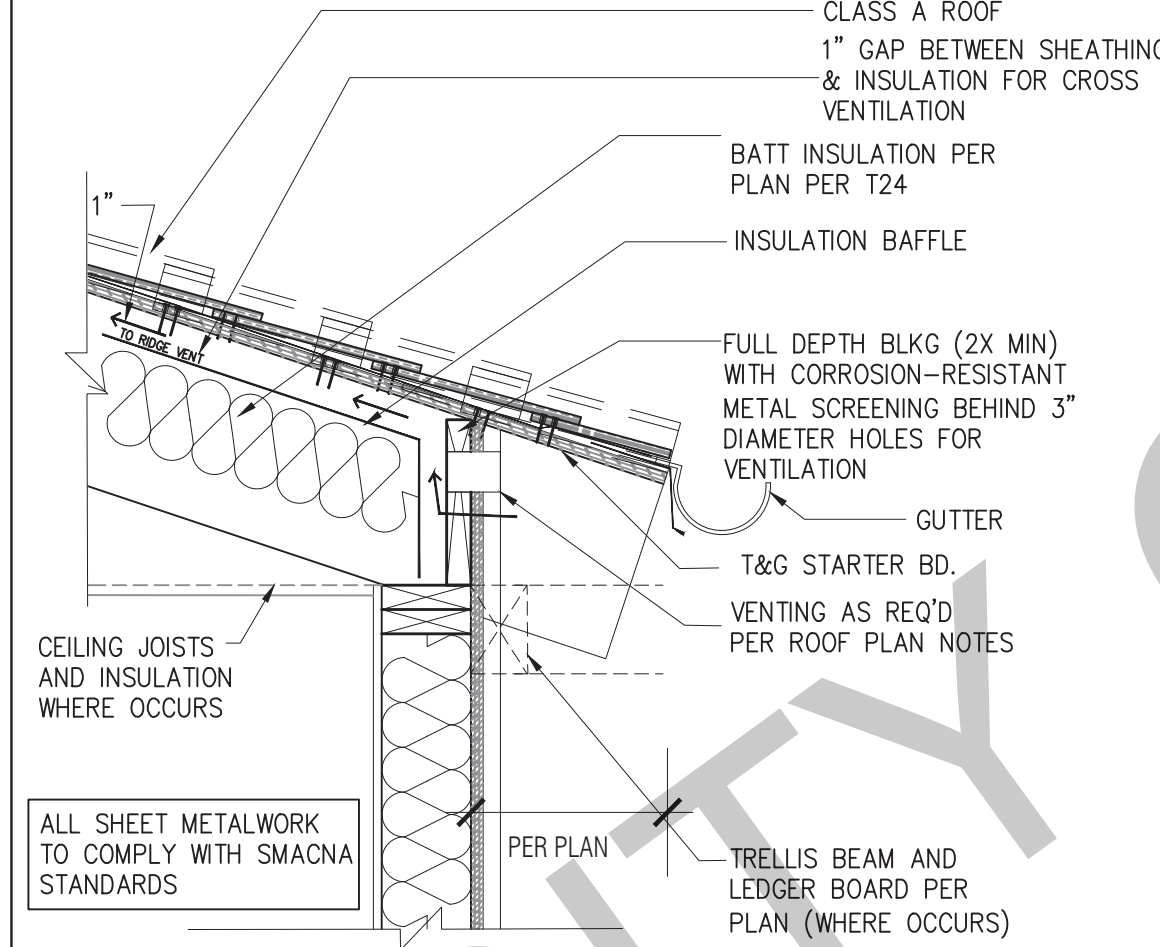

6 IGNITION RESISTIVE RAFTER EAVE HEAVY TIMBER SCALE: 1"=1'-0"

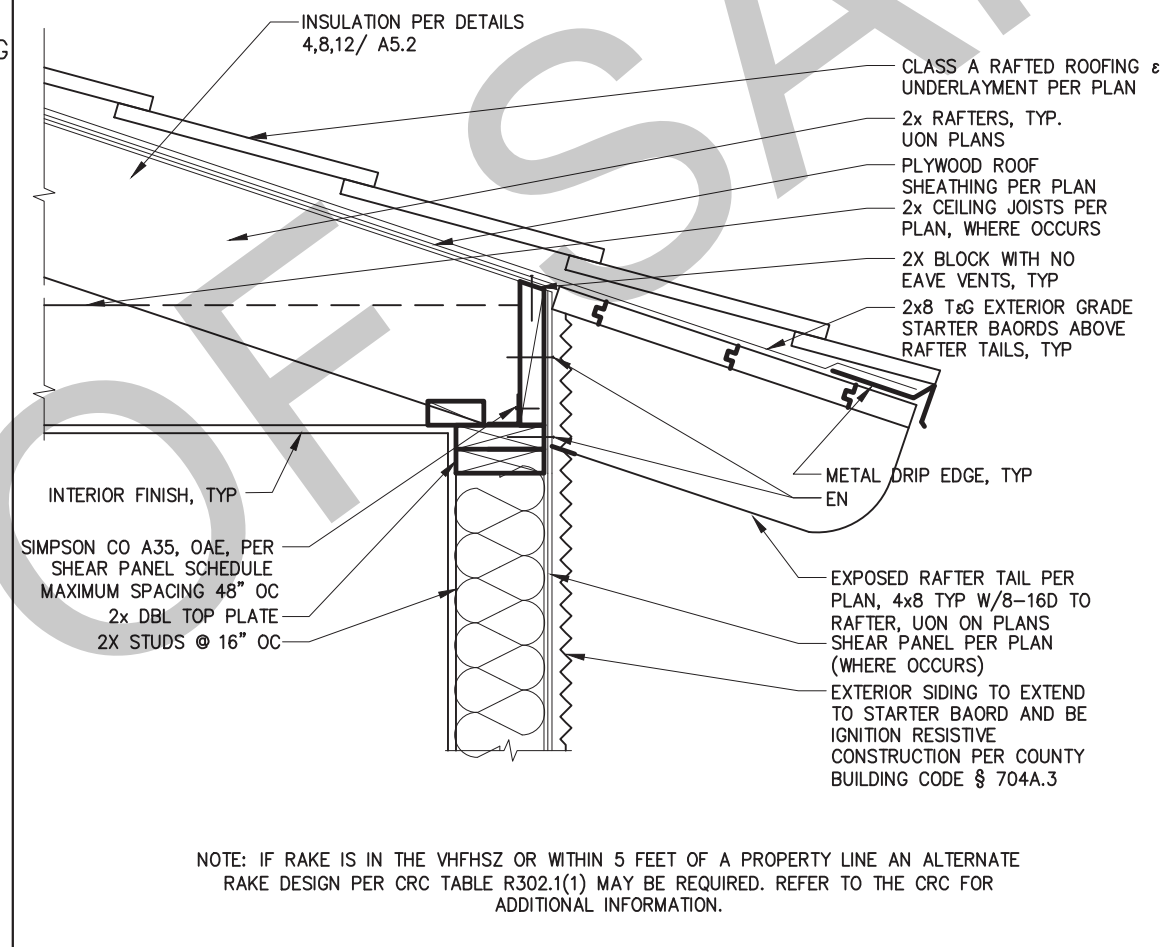

2 IGNITION RESISTIVE GABLE HEAVY TIMBER SCALE: 1"=1'-0"

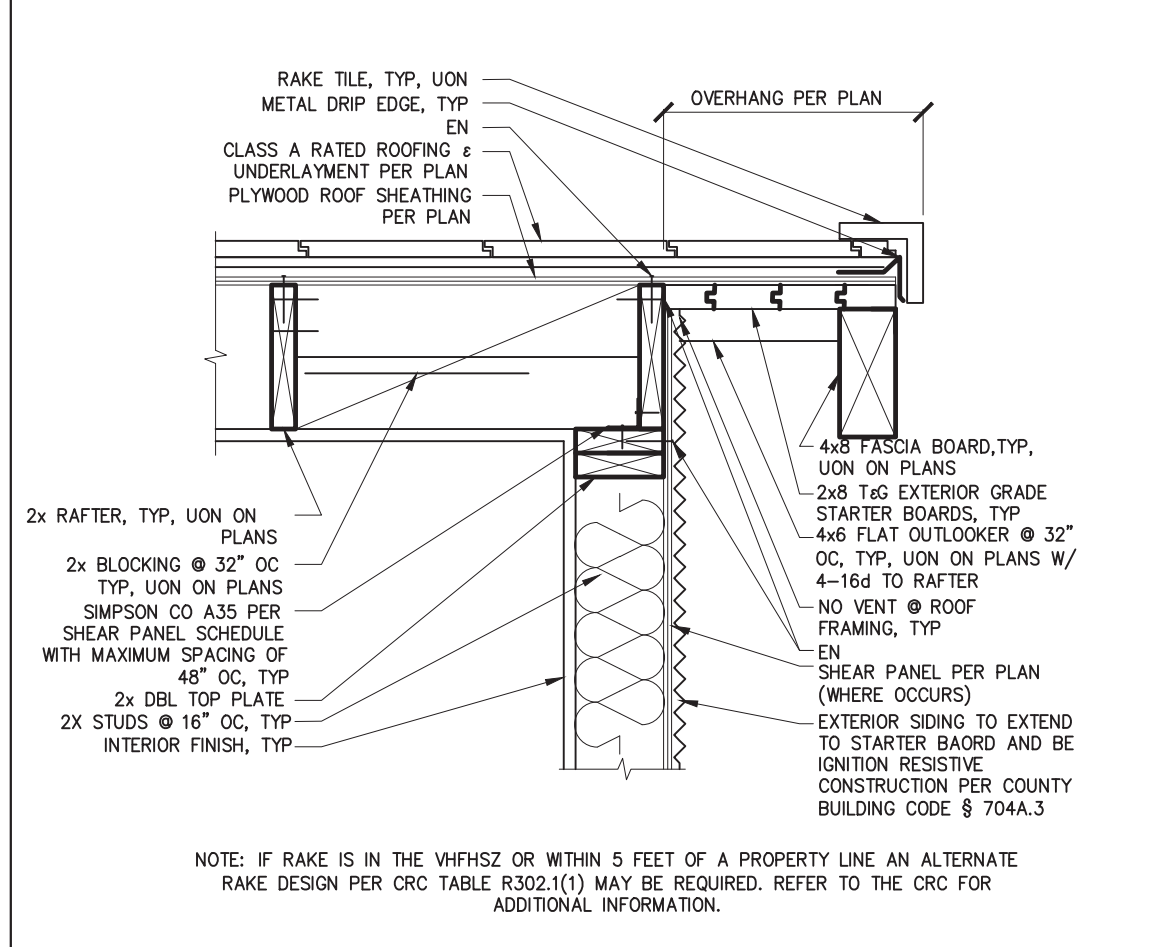

3 IGNITION RESISTIVE GABLE WITH 2x FASCIA SCALE: 1"=1'-0"

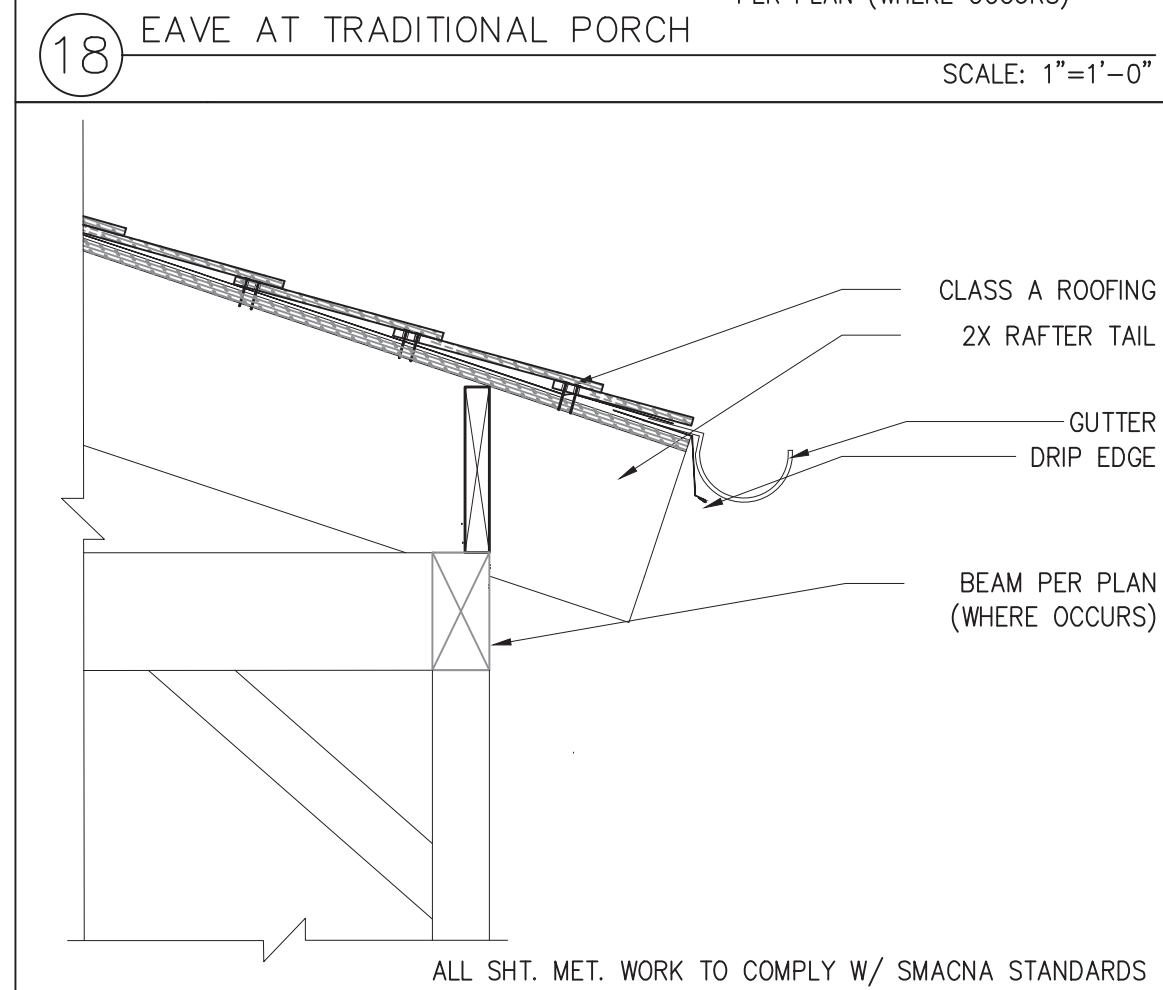

19 EAVE AT RANCH PORCH SCALE: 1"=1'-0"



15 PORCH AWNING TO WALL CONNECTION SCALE: 1"=1'-0"

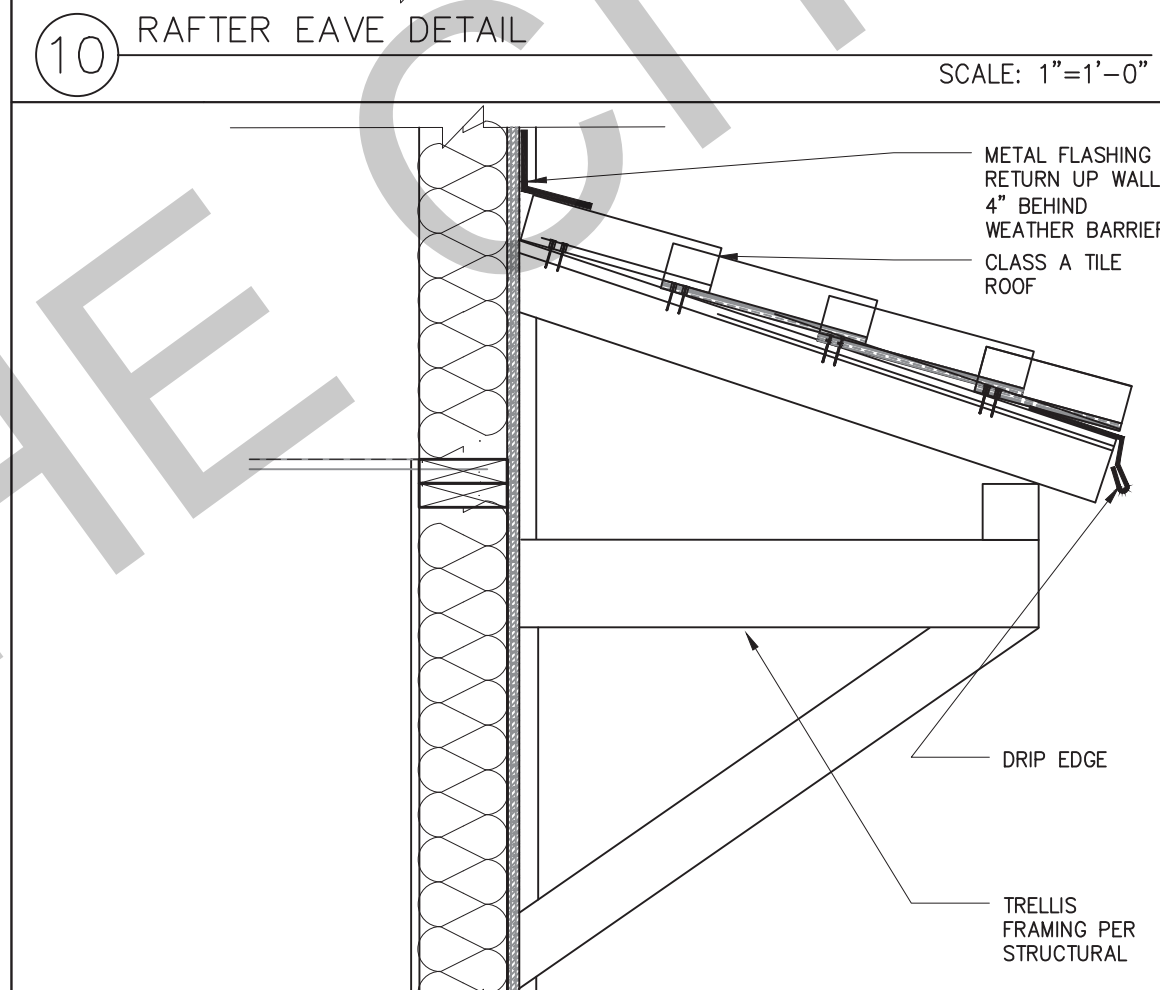

7 IGNITION RESISTIVE RAFTER EAVE WITH 2x FASCIA SCALE: 1"=1'-0"

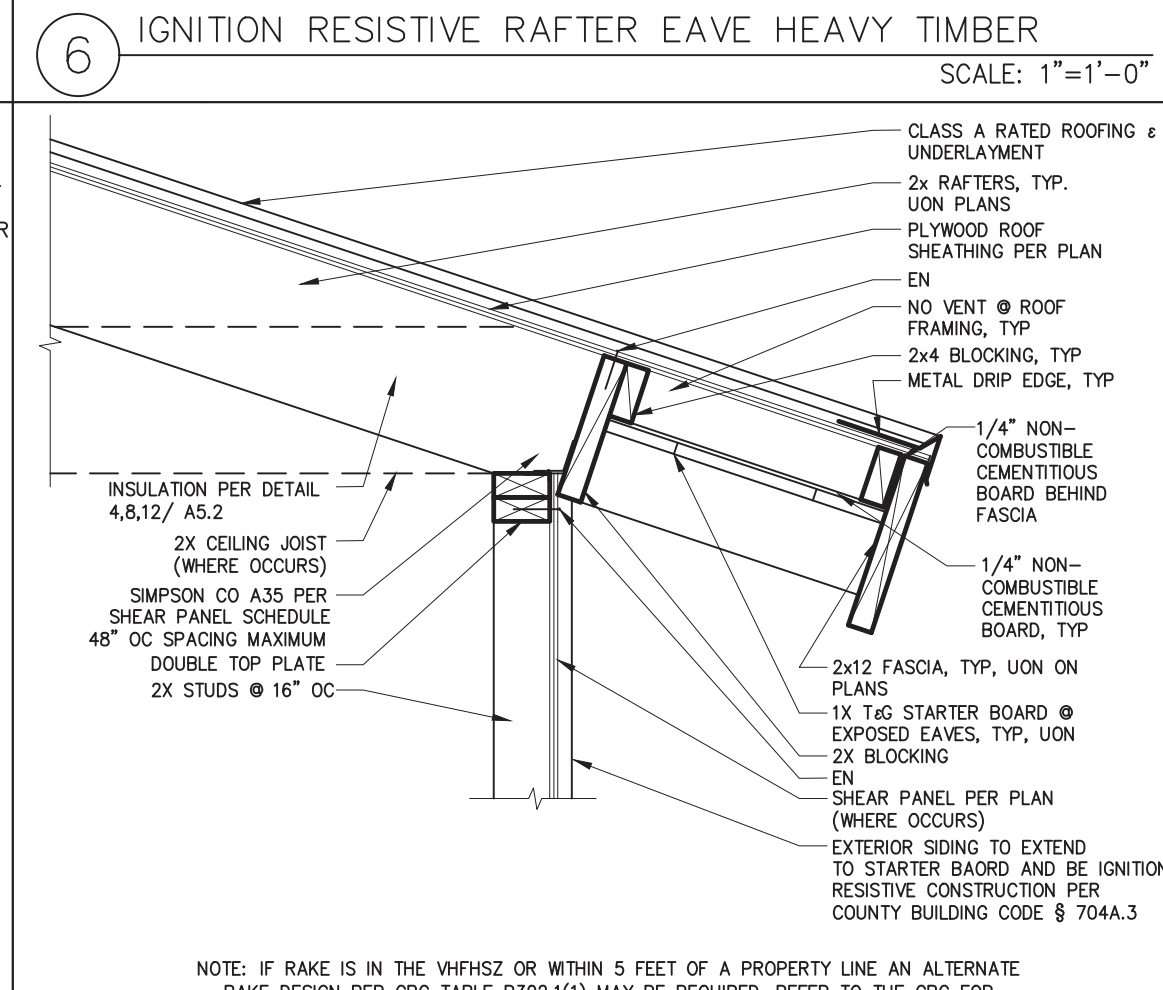

4 INSULATION AT UNVENTED ROOF ASSEMBLY-OVER/UNDER SCALE: 1"=1'-0"

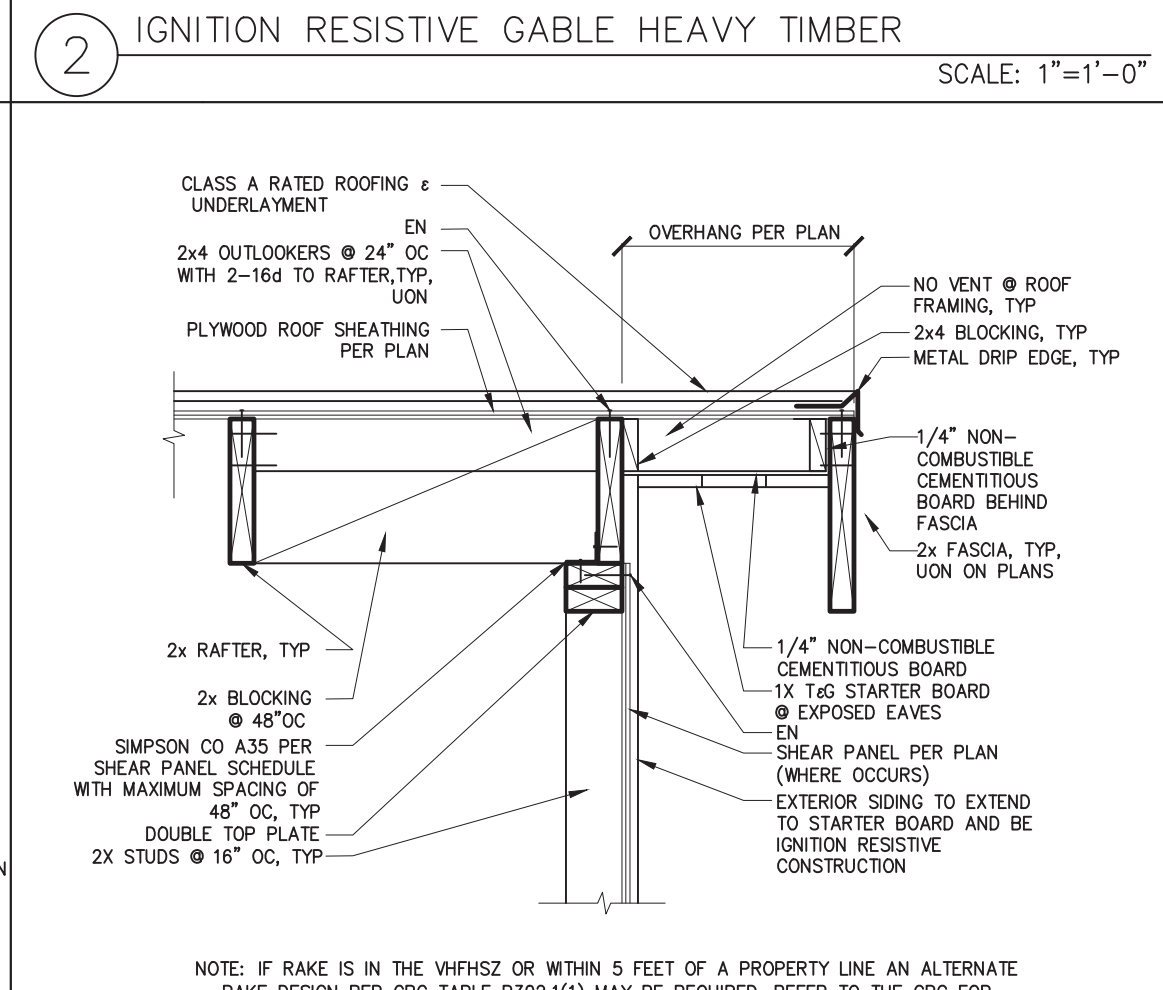

8 INSULATION @ UNVENTED ROOF ASSEMBLY-BOTH TYPES SCALE: 1"=1'-0"

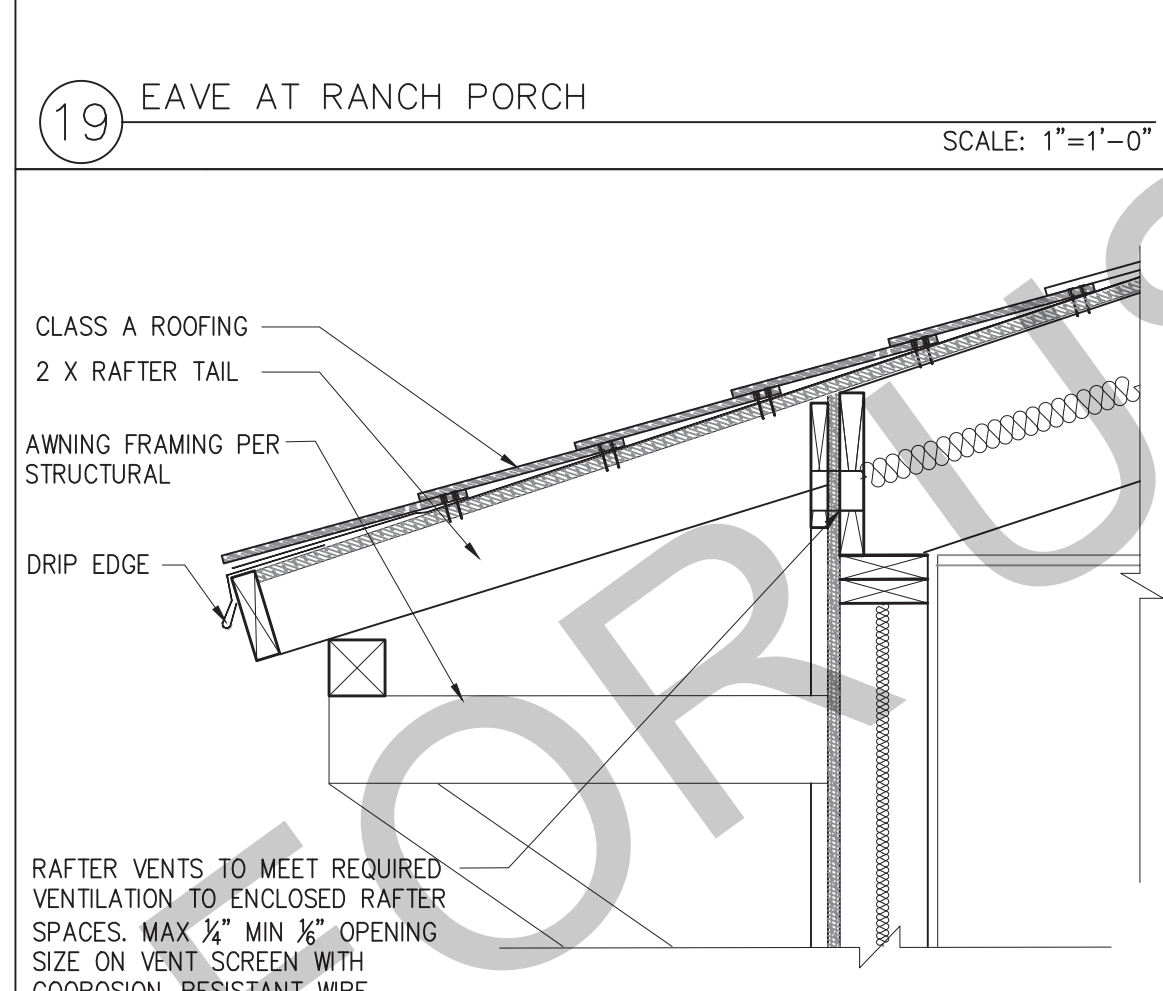

20 PORCH AWNING SCALE: 1"=1'-0"

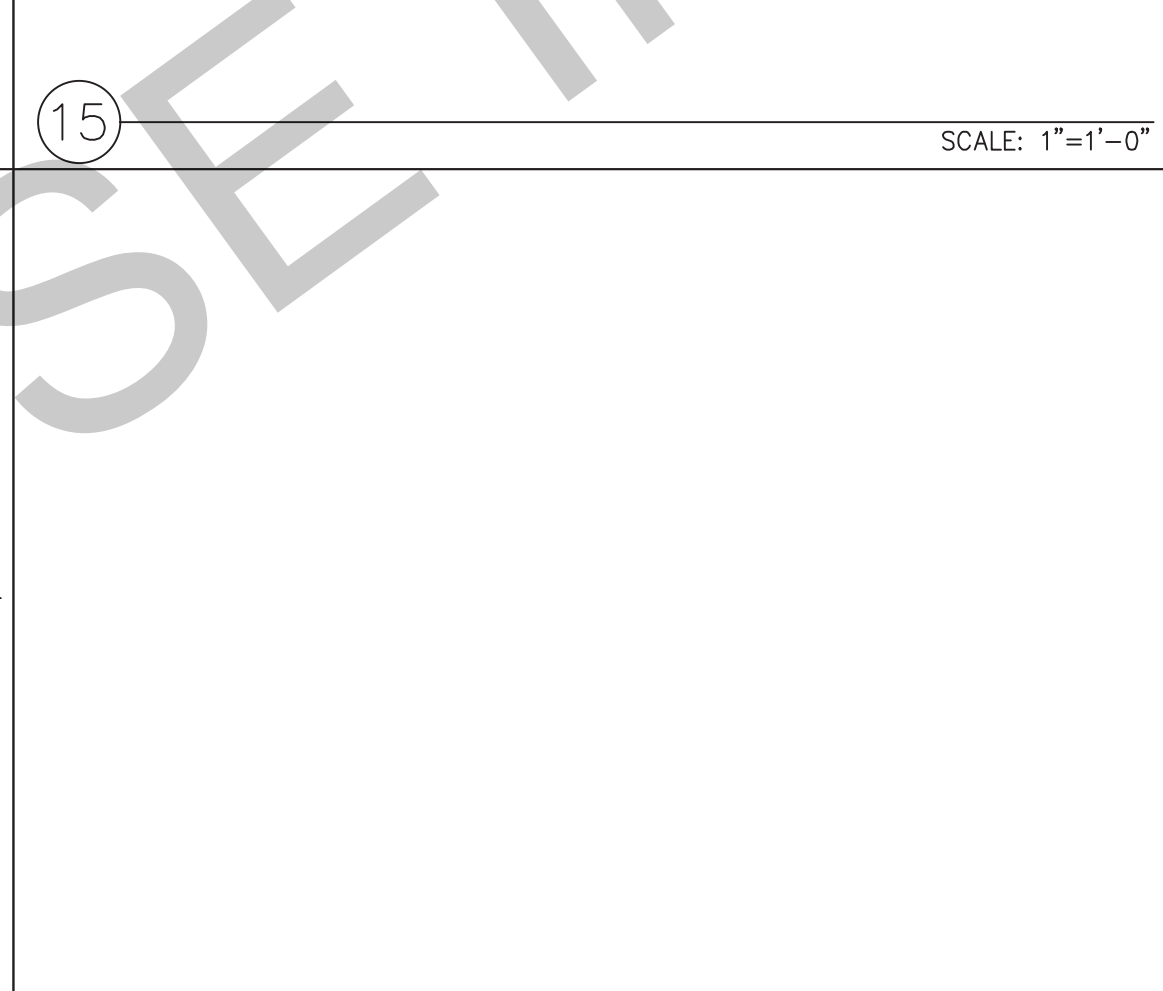

11 INSULATION @ UNVENTED ROOF ASSEMBLY IMPERMEABLE ONLY SCALE: 1"=1'-0"

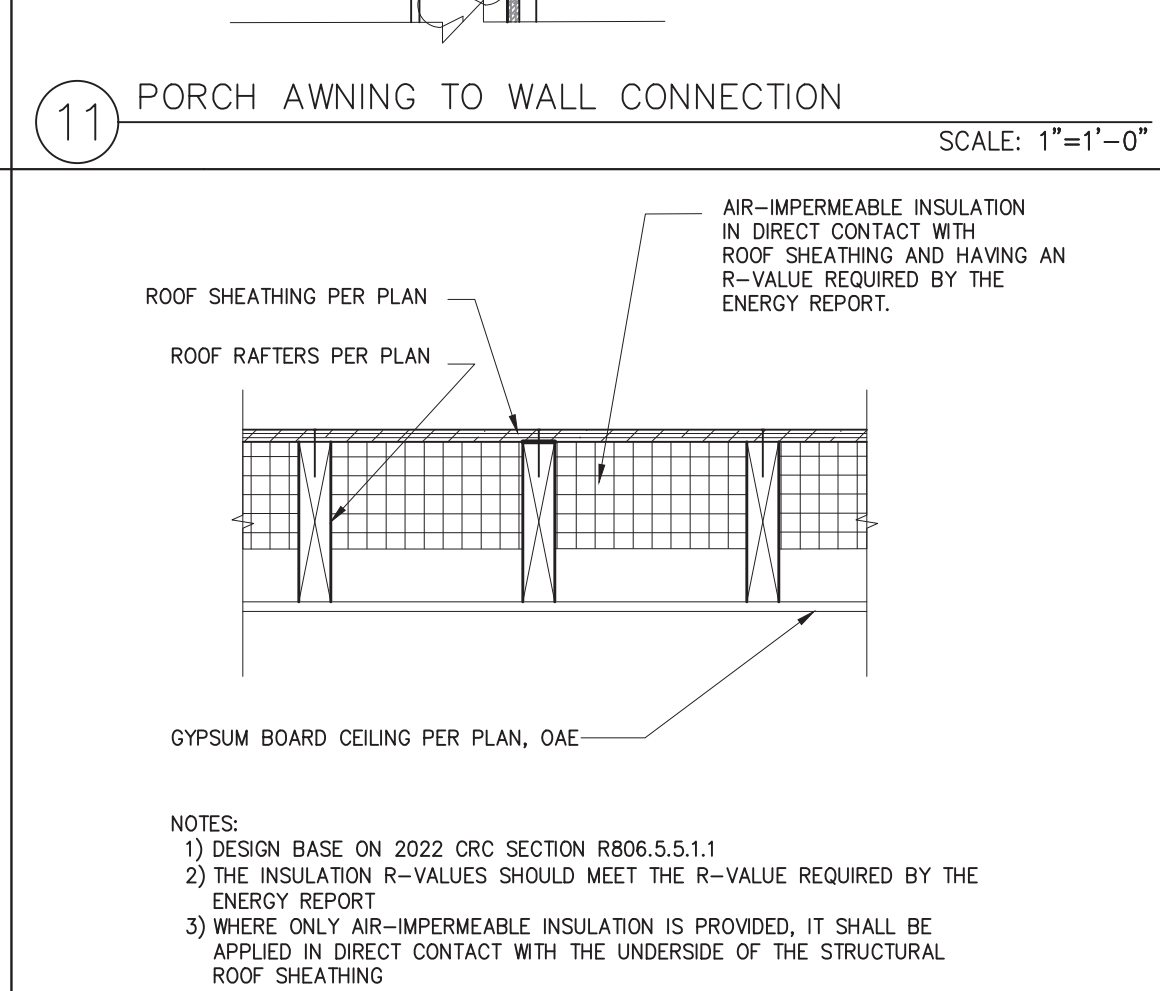

12 INSULATION @ UNVENTED ROOF ASSEMBLY IMPERMEABLE ONLY SCALE: 1"=1'-0"

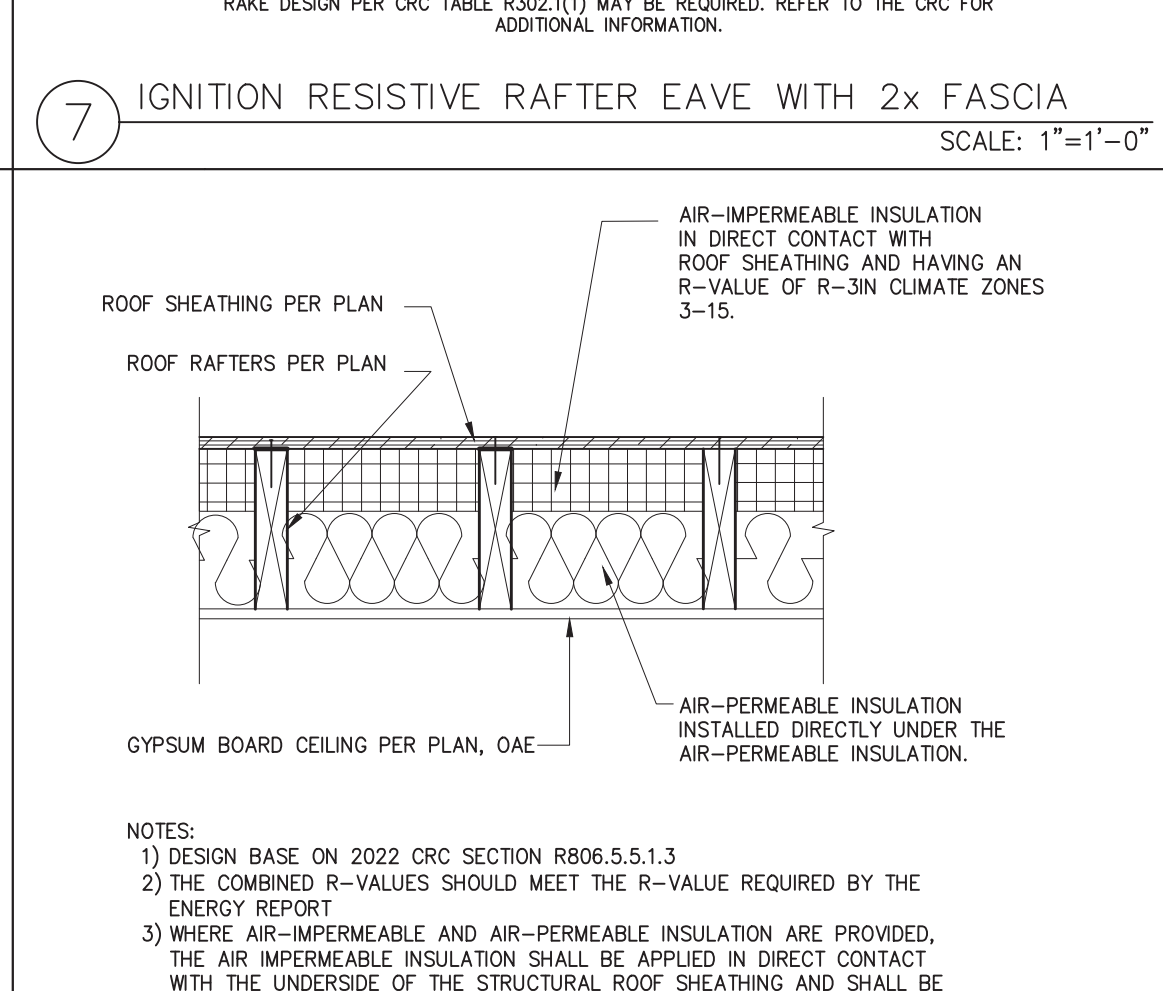

8 INSULATION @ UNVENTED ROOF ASSEMBLY BOTH TYPES SCALE: 1"=1'-0"

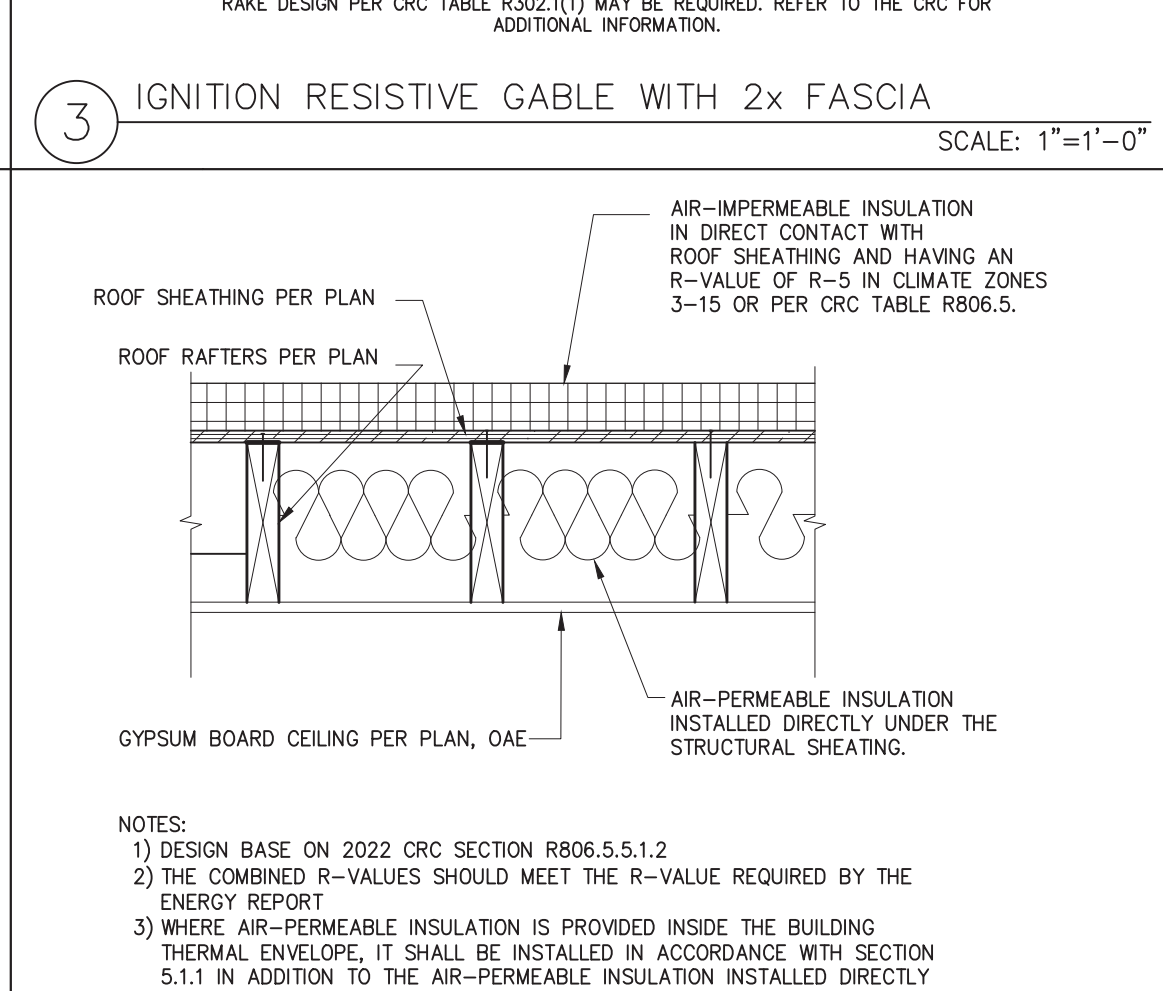

4 INSULATION AT UNVENTED ROOF ASSEMBLY-OVER/UNDER SCALE: 1"=1'-0"

BY USING THESE PERMIT READY CONSTRUCTION DOCUMENTS, THE RECIPIENT ACKNOWLEDGES, ACCEPTS AND VOLUNTARILY AGREES TO THE FOLLOWING CONDITIONS:

1. THE USE OF THIS INFORMATION IS RESTRICTED TO THE ORIGINAL PROJECT FOR WHICH IT WAS PREPARED FOR THE PERMIT READY ACCESSORY DWELLING UNIT (ADU) PROGRAM FOR THE CITY OF SANTA ANA ONLY. THIS IS A LIMITED SET OF STANDARDIZED ADU PLANS AND SPECIFICATIONS APPROVED BY THE CITY OF SANTA ANA BUILDING DEPARTMENT. BUILDING CODES DO CHANGE, OVER TIME AND RECIPIENT SHALL ENSURE FULL COMPLIANCE UNDER ALL CODES THEN IN EFFECT AT THE TIME OF THE SUBJECT PERMIT. THIS DOES NOT ELIMINATE OR REDUCE THE RECIPIENT'S RESPONSIBILITY TO VERIFY ANY AND ALL INFORMATION RELEVANT TO THE RECIPIENT'S WORK AND RESPONSIBILITY ON THIS PROJECT. DESIGN PATH STUDIO SHALL NOT BE RESPONSIBLE FOR TRANSLATION ERRORS. DO NOT USE THESE CONSTRUCTION DOCUMENTS IF THE PERMIT HAS EXPIRED OR IS REVOKED AT ALL.
2. THE RECIPIENT ACKNOWLEDGES AND AGREES THAT THE USE OF THIS INFORMATION WILL BE AT THEIR SOLE RISK AND WITHOUT ANY LIABILITY OR LEGAL EXPOSURE TO DESIGN PATH STUDIO. NO WARRANTIES OF ANY NATURE, WHETHER EXPRESS OR IMPLIED, SHALL ATTACH TO THESE DOCUMENTS AND THE INFORMATION CONTAINED THEREON. ANY USE, REUSE, OR ALTERATION OF THESE DOCUMENTS BY THE RECIPIENT OR BY OTHERS WILL BE AT THE RECIPIENT'S RISK AND FULL LEGAL RESPONSIBILITY. FURTHERMORE, THE RECIPIENT WILL, TO THE FULLEST EXTENT PERMITTED BY LAW, DEFEND, INDEMNIFY AND HOLD DESIGN PATH STUDIO AND ITS ARCHITECTS HARMLESS FROM ANY AND ALL CLAIMS, SUITS, LIABILITY, DEMANDS, JUDGMENTS, OR COSTS ARISING OUT OF OR RESULTING THERE FROM ANY USE OF THESE CONSTRUCTION DOCUMENTS FOR OR ON ACCOUNT OF ANY INJURY, DEATH, DAMAGE OR LOSS TO PERSONS OR PROPERTY, DIRECT OR CONSEQUENTIAL DAMAGES IN ANY AMOUNT. THIS INDEMNITY DOES NOT APPLY TO THE SOLE NEGLIGENCE OR WILLFUL MISCONDUCT OF DESIGN PATH STUDIO OR ITS ARCHITECTS.
3. THE DESIGNS REPRESENTED BY THESE PLANS ARE COPYRIGHTED AND ARE SUBJECT TO COPYRIGHT PROTECTION.
4. IF THE RECIPIENT DOES NOT AGREE WITH THE ABOVE CONDITIONS, DO NOT PROCEED WITH CONSTRUCTION OF AN ADU OR OTHER IMPROVEMENT UNDER THESE PLANS AT ALL.

project  
Santa Ana  
ADU  
address

revisions

description  
Architectural  
Roof Finish  
Details

date MAY 2023

project no. 2022\_SANTA\_ANA\_ADU

drawn by DESIGN PATH STUDIO

sheet no. **A5.2**