



CITY OF SONOMA - TOOLKIT DOCUMENT #1a

Submittal Requirements for Solar Domestic Water Heating Installations 30 kWth or Less for One- and Two-Family Dwellings

This information bulletin is published to guide applicants through a streamlined permitting process for solar domestic water heating (SDWH) projects 30 kWth (462 square foot) in size or smaller. This bulletin provides information about submittal requirements for plan review, required fees and inspections.

1. Approval Requirements

The following permits are required to install a SDWH system with a maximum thermal output of 30 kWth or less:

- a) A completed City of Sonoma Building Permit application (available at Sonoma City Hall or on the City's web site at <http://www.sonomacity.org/Government/Departmental-Offices/Building.aspx> .) is required for all solar system installations.
- b) Planning Department and Fire Department plan review and inspection is not required for solar domestic water heating installations for one- and two-family dwellings of 30 kWth or less.

2. Submittal Requirements

- a) NOTE: All information, forms and checklists described below are available on the City's web page for Expedited Solar Permitting for One- & Two-Family Dwellings located at <http://www.sonomacity.org/Government/Departmental-Offices/Building.aspx> .
- b) A completed building permit application form must be submitted.
- c) Demonstrate compliance with the Eligibility Checklist for Expedited Permitting (Toolkit Document #2a).
- d) A completed Plumbing plan must be provided. A Standard Plan template (Toolkit Documents #3a) may be used for proposed solar domestic water heating installations of 30 kWth in size or smaller.

The standard plan should include, but not be limited to, the following information:

- Total number of collectors and area
 - Make, model and collector certification number
 - System certification number
 - Solar storage tank name, model, insulation and capacity
 - Heat exchanger make and model (if applicable)
 - Specifications of heat transfer fluid (if applicable)
- e) A roof plan showing roof layout and solar collectors with attachment details. e) System schematic, including major components. A satellite image of the roof with solar panels overlaid is not an acceptable roof plan.
 - f) Equipment cut sheets including collectors, controller, storage tank/heat exchanger (if applicable).

- g) A completed Structural Criteria for Expedited Permitting of Residential Rooftop Solar Energy Installations form (Toolkit Document #5) along with required documentation.

For non-qualifying systems, provide structural drawings and calculations stamped and signed by a California-licensed Civil or Structural Engineer, along with the following information.

- The type of roof covering and the number of roof coverings installed.
 - Type of roof framing, size of members and spacing.
 - Weight of collector panels, support locations and method of attachment.
 - Framing plan and details for any work necessary to strengthen the existing roof structure.
 - Site-specific structural calculations.
 - Where an approved racking system is used, provide documentation showing manufacturer of the rack system, maximum allowable weight the system can support, attachment method to the roof or ground and product evaluation information or structural design for the rack system.
- h) A completed Smoke Alarm & Carbon Monoxide Alarm Declaration form available on the City's web site. The California Residential Code requires that smoke and carbon monoxide alarms be provided in all residential buildings where a building permit is issued for additions, alterations or repairs with a valuation exceeding \$1,000.

3. Plan Review

Permit applications can be submitted to the City of Sonoma Building Department in person at City Hall, #1 The Plaza, Sonoma, CA and electronically through e-mail. E-mail addresses are available under the Contact Numbers expandable box at <http://www.sonomacity.org/Government/Departmental-Offices/Building.aspx>.

Permit applications utilizing fully completed standard plan templates are eligible for the expedited permitting process for small residential rooftop solar energy systems.

Permit applications eligible for the expedited permitting process will receive a high review priority and be reviewed as early as practical with a processing goal of one to three business days following receipt of the submittal.

4. Fees

An initial building permit deposit of \$100.00 must accompany all building permit applications at the time of submittal. The deposit will be applied towards the total cost of the building permit and is used to help cover initial processing, plan review and other applicable fees for service. The total cost for building permits for expedited small residential rooftop solar energy systems is dependent on a number of factors but generally cost in in the range of \$250 - \$350.

5. Inspections

Once all permits to construct the solar installation have been issued and the system has been installed, it must be inspected before final approval is granted for the solar system. On-site inspections can be scheduled by contacting the City of Sonoma Building Department by telephone at 707-938-3681. Inspection requests received during City Hall business hours can typically be scheduled for the next business day.

Permit holders must provide the inspector with the Building Department Approved Job Plans, the Building Permit Inspection Record Card and access to the location of the work. The permittee must be prepared to show conformance with all technical requirements in the field at the time of inspection. The inspector will verify that the installation is in conformance with applicable code requirements and the approved plans.

The inspection checklist (Toolkit Document #7a) provides an overview of common points of inspection, and the applicant should be prepared to show compliance with these points.

6. Departmental Contact Information

For additional information regarding this permit process, please consult our departmental website at <http://www.sonomacity.org/Government/Departmental-Offices/Building.aspx> or contact the Building Department at 707-938-3681.



CITY OF SONOMA - TOOLKIT DOCUMENT #2a

Eligibility Checklist for Expedited Solar Domestic Water Heating Permitting for One- and Two-Family (Duplex) Dwellings

PROJECT ADDRESS:

GENERAL REQUIREMENTS

- A. System size is 30 kWth (462 square feet of collector) or less. Y N
- B. The solar array is roof-mounted on one- or two-family dwelling or accessory structure. Y N
- C. The solar collector arrays will not exceed the maximum legal building height. Y N
- D. Solar collectors are certified by an accredited listing agency. Y N
- E. Solar domestic water heating system is certified by an accredited listing agency. Y N
- F. A permit application is completed and attached. Y N
- G. System schematic is included. Y N
- H. List of major components to match system schematic is provided. Y N
- I. Heat transfer fluid is either water or a nontoxic fluid. Y N

PLUMBING REQUIREMENTS

- A. Adequate extreme temperature protection is provided. Y N
- B. Standard one-line plumbing diagram is provided with components showing solar interface with existing plumbing. Y N

STRUCTURAL REQUIREMENTS

- A. A completed Structural Criteria or evaluation and supporting documentation is attached. Y N

FIRE SAFETY REQUIREMENTS

- A. SMOKE and CARBON MONOXIDE ALARMS will be provided in accordance with the requirements of sections R314 and R315 of the California Residential Code. Y N

Note:

These criteria are intended for the expedited solar permitting process. If any items are checked NO, revise the design to fit within Eligibility Checklist, otherwise the permit application will go through the City's standard plan review process.



CITY OF TOOLKIT DOCUMENT #3a

Domestic Solar Water Heating Standard Plan for One- and Two-Family Dwellings

SCOPE: Use this plan ONLY for solar domestic water heating systems not exceeding a thermal output rating of 30 kWth on the roof of a one- or two-family dwelling or accessory structure and used for domestic water heating. Systems must be in compliance with current California Building Standards Code, Title 24 and local amendments of the City of Sonoma. Other articles of the California Plumbing Code (CPC) or California Mechanical Code (CMC) or other California health and safety codes shall apply.

MANUFACTURER'S SPECIFICATION SHEETS MUST BE PROVIDED for proposed collector, controller, pump, storage tank/heat exchanger/ heat transfer fluid (if applicable) and mounting systems. Equipment intended for use with SWH system shall be identified and listed for the application.

Applicant and Site Information

Job Address: _____

Contractor Name: _____ License # / Class _____ / _____

Signature: _____ Date: _____ Phone Number _____

Email: _____

Major Components (for Solar Domestic Water Heating system)

Total # of Collectors Installed _____ Total Area of Collectors _____ s.f.

Collector Certification Number (include certifying agency) _____

System Certification Number (include certifying agency) _____

Installed Max Height Above Roof _____ ft. Installed Height Above Ground _____ ft.

Solar Tank Make/Model _____

Gallons _____ Insulation R- _____ Pressurized? Y N

Heat Exchanger Make/Model _____ Manuf. Cut Sheet submitted? Y N

Heat Exchange Fluid? _____ Manuf. Cut Sheet submitted? Y N

Solar Control Make/Model _____ Manuf. Cut Sheet submitted? Y N

Solar Pump/Circulator Make/Model _____ Manuf. Cut Sheet submitted? Y N

Expansion Tank Make/Model _____ Manuf. Cut Sheet submitted? Y N

Appropriately Sized for Use? Y N

Mounting Hrdw Make/Model or Type _____ Manuf. Cut Sheet submitted? Y N

Do all the above data match substantially the data used for certification? Y N

Solar Domestic Water Heating Standard Plan – Simplified - for One- and Two-Family Dwellings

(Print on 11 x 17" paper)

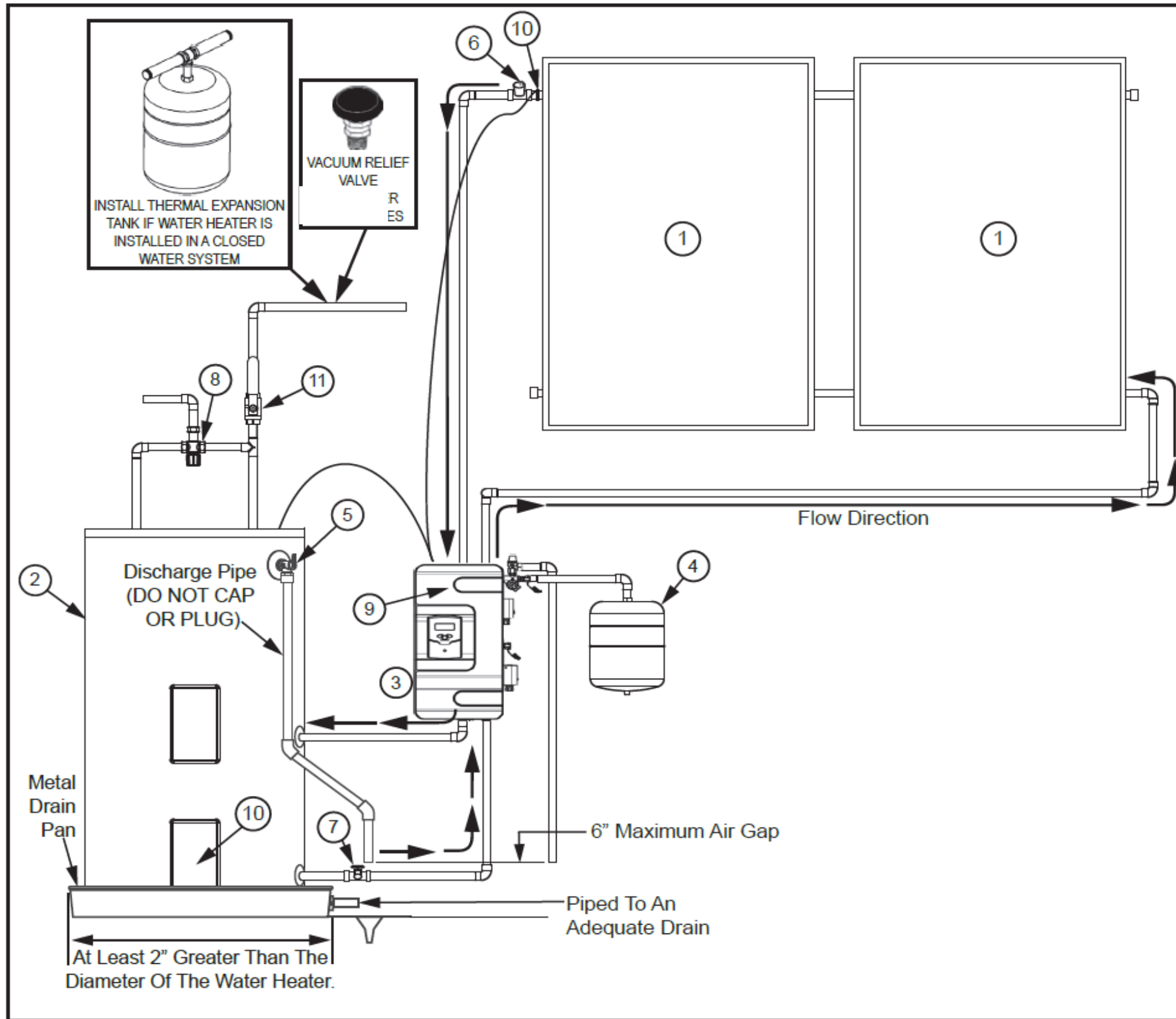

Schedule of Components		
Ref. Tag #	Item	Description, Size, Type, Model, Etc. Indicate if New (N), Existing(E) or Not Applicable (N/A)
1	Solar Collectors	
2	Solar Storage Tank	
3	Double Wall Heat Exchanger (Inside Solar Pump Station)	
4	Solar Loop Expansion Tank	
5	Temp. & Pressure Relief Valve	
6	Air Vent	
7	Drain Valves	
8	Mixing Valve	
9	Solar Pump Station	
10	Temperature Sensor	
11	Cold Water Cut-Off Valve	

PROJECT ADDRESS: _____

Solar Domestic Water Heating Roof Plan

(Print on 11 x 17" paper)

Items required: Illustrate the roof layout (hips, valleys ridges and edges) . Show the layout of all collector panels and approximate locations of equipment and roof access points. Specify the roof slope for each roof plane and dimension the clear access pathways required by the CA Fire Code. Identify the direction of North on the plan. Indicate the drawing scale used.

**Solar Domestic Water Heating
Roof Layout Diagram**

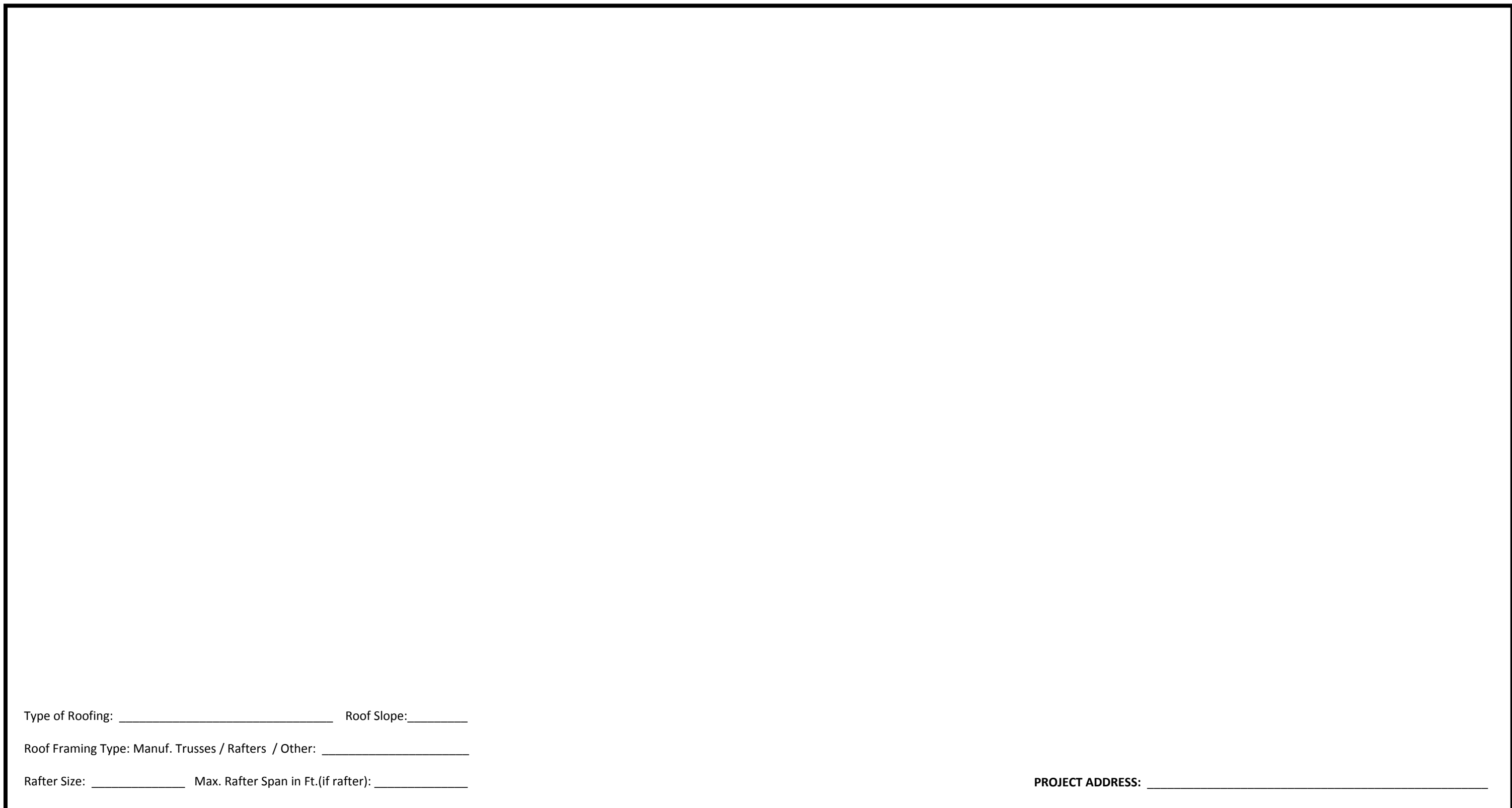

Type of Roofing: _____ Roof Slope: _____

Roof Framing Type: Manuf. Trusses / Rafters / Other: _____

Rafter Size: _____ Max. Rafter Span in Ft.(if rafter): _____

PROJECT ADDRESS: _____



Structural Criteria for Expedited Permitting of Residential Rooftop Solar Energy Installations

Use of this document

Applicants for Expedited Permitting of Residential Rooftop Solar Energy Installations must complete and submit this document in its entirety. This document applies to flush-mounted solar arrays installed on the roofs of wood-framed one- and two-family dwellings. "Flush-mounted" means the collectors are installed parallel to, and relatively close to, the roof surface (see the "Solar Array Check" section of the Structural Criteria for specific qualifying requirements). This list is intended to be a simple pre-installation check to gain reasonable assurance that the design of the solar array complies with the structural provisions of the 2016 California Building Code (CBC) and 2016 California Residential Code (CRC).

Job Address: _____

1. ROOF CHECKS

A. Visual Review/Contractor's Site Audit of Existing Conditions:

- 1) Is the roof a single roof without a reroof overlay? Y N
- 2) Does the roof structure appear structurally sound, without signs of alterations or significant structural deterioration or sagging, as illustrated in Figure 1? Y N

B. Roof Structure Data:

- 1) Measured roof slope (e.g. 6:12): _____:12
- 2) Measured rafter spacing (center-to-center): _____ inches o.c.
- 3) Type of roof framing (rafter or manufactured truss): Rafter Truss
- 4) Smallest measured rafter size (e.g. 2x4): (Not Applicable if Truss N/A) _____"x _____" (inches)
- 5) Longest measured rafter horizontal span (see Figure 4): (if Truss N/A) _____'-_____'' (ft-in)
- 6) Maximum allowed horizontal rafter span per Table 2: (if Truss N/A) _____'-_____'' (ft-in)
- 7) Is the span on line 5) above less than the span on line 6) above? (if Truss N/A) Y N

2. SOLAR ARRAY CHECKS

A. Flush-mounted Solar Array:

- 1) Is the plane of the modules (panels) parallel to the plane of the roof? Y N
- 2) Is there a 2" to 10" gap between underside of collector and the roof surface? Y N
- 3) Collectors do not overhang any roof edges (ridges, hops, gable ends, eaves)? Y N

B. Do the collectors plus support components weigh no more than 4 psf for photovoltaic arrays or 5 psf for solar thermal arrays?

Y N

C. Does the array cover no more than half of the total roof area (all roof planes)?

Y N

D. Are solar support component manufacturer's project-specific completed worksheets, tables with relevant cells circled, or web-based calculator results attached?

Y N

E. Is a roof plan of the collector and anchor layout attached? (see Figure 2)

Y N

F. Downward Load Check (Anchor Layout Check):

- 1) Proposed anchor horizontal spacing (see Figure 2): _____'-_____'' (ft-in)
- 2) Horizontal anchor spacing per Table 1: _____'-_____'' (ft-in)
- 3) Is proposed horizontal anchor spacing equal to or less than Table 1 spacing? Y N

G. Wind Uplift Check (Anchor Fastener Check):

- 1) Anchor fastener data (see Figure 3):
- a. Are 5/16" diameter lag screws with 2.5" embedment into the rafter used, OR does the anchor fastener meet the manufacturer's guidelines? Y N

3. SUMMARY

A. All items above are checked (Y) YES or (N/A). No additional calculations are required. Y N

B. One or more items are checked (N) NO. Attach project-specific drawings and calculations stamped and signed by a California-licensed Civil or Structural Engineer. Y N

Contractor/Installer that performed Structural Audit: _____
(Please print)

Signature: _____ Date: _____

Tables and Figures:

Table 1. Maximum Horizontal Anchor Spacing				
Roof Slope		Rafter Spacing		
		16" o.c.	24" o.c.	32" o.c.
Photovoltaic Arrays (4 psf max)				
Flat to 6:12	0° to 26°	5'-4"	6'-0"	5'-4"
7:12 to 12:12	27° to 45°	1'-4"	2'-0"	2'-8"
13:12 to 24:12	46° to 63°	1'-4"	2'-0"	2'-8"
Solar Thermal Arrays (5 psf max)				
Flat to 6:12	0° to 26°	4'-0"	4'-0"	5'-4"
7:12 to 12:12	27° to 45°	1'-4"	2'-0"	2'-8"
13:12 to 24:12	46° to 63°	Calc. Req'd	Calc. Req'd	Calc. Req'd

Solar support component manufacturer's guidelines may be relied upon to ensure the array above the roof is properly designed, but manufacturer's guidelines typically do NOT check to ensure that the roof itself can support the concentrated loads from the solar array. Table 1 assumes that the roof complied with the building code in effect at the time of construction, and places limits on anchor horizontal spacing to ensure that a roof structure is not overloaded under either downward loads or wind uplift loads. Note 4 below lists the basic assumptions upon which this table is based.

Table 1 Notes:

- Anchors are also known as "stand-offs", "feet", "mounts" or "points of attachment". Horizontal anchor spacing is also known as "cross-slope" or "east-west" anchor spacing (see Figure 2).
- If anchors are staggered from row-to-row going up the roof, the anchor spacing may be twice that shown above, but no greater than 6'-0".
- For manufactured plated wood trusses at slopes of flat to 6:12, the horizontal anchor spacing shall not exceed 4'-0" and anchors in adjacent rows shall be staggered.
- This table is based on the following assumptions:
 - The roof structure conformed to building code requirements at the time it was built.
 - The attached list of criteria are met.
 - Mean roof height is not greater than 40 feet.
 - Roof sheathing is at least 7/16" thick oriented strand board or plywood. 1x skip sheathing is acceptable.
 - If the dwelling is in Wind Exposure B (typical urban, suburban or wooded areas farther than 500 yards from large open fields), no more than one of the following conditions apply:
 - The dwelling is located in a special wind region with design wind speed between 115 and 130 mph per ASCE 7-10, or
 - The dwelling is located on the top half of a tall hill, provided average slope steeper is less than 15%.
 - If the dwelling is In Wind Exposure C (within 500 yards of large open fields or grasslands), all of the following conditions apply:
 - Design wind speed is 110 mph or less (not in a Special Wind Region), and
 - The dwelling is not located on the top half of a tall hill.
 - The solar array displaces roof live loads (temporary construction loads) that the roof was originally designed to carry.

Table 2. Roof Rafter Maximum Horizontal Span (feet - inches) 1								
Assumed Vintage	Nominal Size	Actual Size	Non-Tile Roof ²			Tile Roof ³		
			Rafter Spacing					
			16" o.c.	24" o.c.	32" o.c.	16" o.c.	24" o.c.	32" o.c.
Post-1960	2x4	1½"x3½"	9'-10"	8'-0"	6'-6"	8'-6"	6'-11"	5'-6"
	2x6	1½"x5½"	14'-4"	11'-9"	9'-6"	12'-5"	10'-2"	8'-0"
	2x8	1½"x7¼"	18'-2"	14'-10"	12'-0"	15'-9"	12'-10"	10'-3"
Pre-1960	2x4	1¾"x3¾"	11'-3"	9'-9"	7'-9"	10'-3"	8'-6"	6'-9"
	2x6	1¾"x5¾"	17'-0"	14'-0"	11'-3"	14'-9"	12'-0"	9'-9"
	2x8	1¾"x7¾"	22'-3"	18'-0"	14'-6"	19'-0"	15'-6"	12'-6"

Beyond a visual review by the Contractor checking for unusual sagging or deterioration, some CBOs may want additional assurance that the roof structure complies with structural building code requirements. Table 2 is an optional table some CBOs may elect to use to provide additional assurance by requiring a check of existing roof rafter spans, and supports optional criteria 1.B.5 and 1.B.6. For post-1960 construction, these span tables match the rafter span tables found in the 2016 California Building and Residential codes. For pre-1960 construction, the rafter span tables are based on structural calculations with lumber sizes and wood species & grade appropriate for older construction. Note 5 below lists the basic assumptions upon which this table is based.

Table 2 Notes:

1. See Figure 4 for definition of roof rafter maximum horizontal span.
2. "Non-tile Roof" = asphalt shingle, wood shingle & wood shake, with an assumed roof assembly weight of 10 psf.
3. "Tile Roof" = clay tile or cement tile, with an assumed roof assembly weight of 20psf
4. Unaltered manufactured plated-wood trusses may be assumed to be code compliant and meet intent of Table 2.
5. This table is based on the following assumptions:
 - Span/deflection ratio is equal to or greater than 180.
 - For post-1960 construction, wood species and grade is Douglas Fir-Larch No. 2.
 - For pre-1960 construction, wood species and grade is Douglas Fir-Larch No. 1.
 - Other wood species and/or grade are also acceptable if allowable bending stress is equal or greater to that listed above.

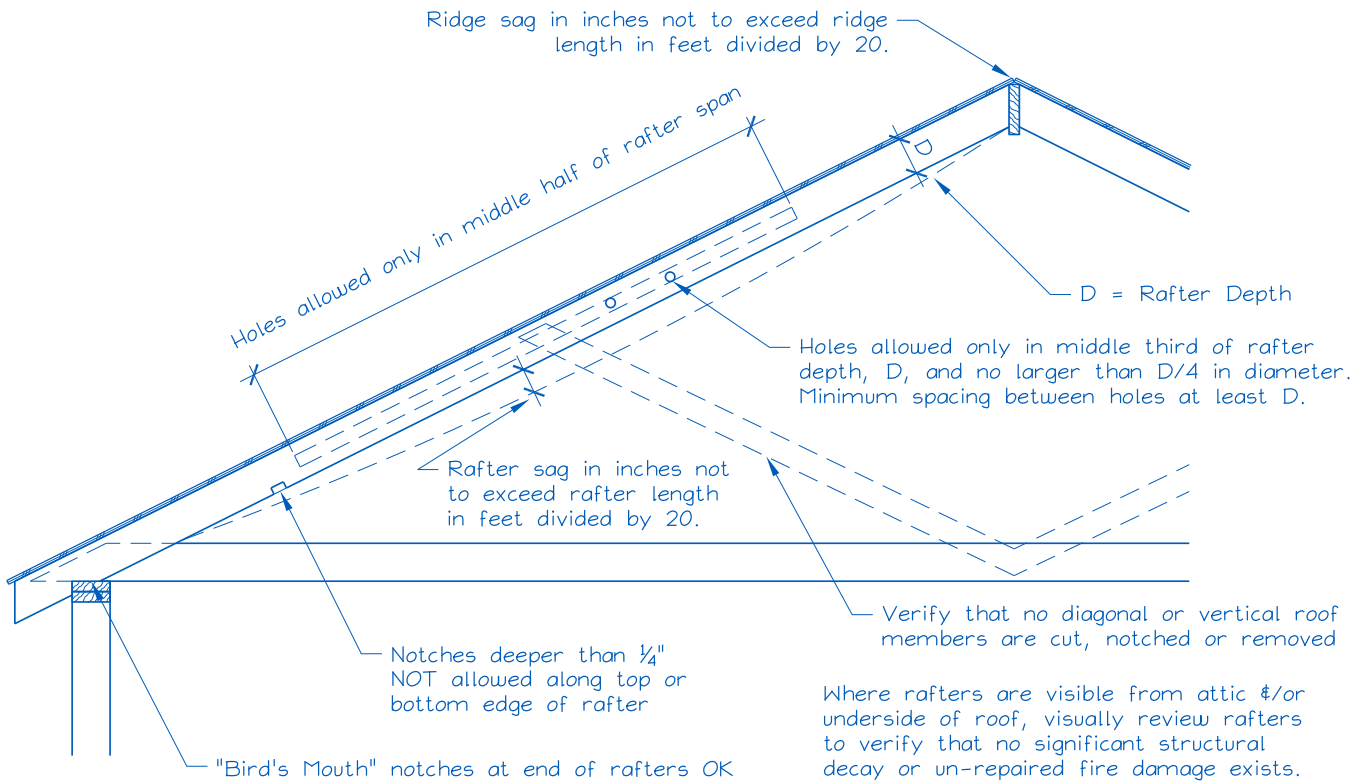

Figure 1. Roof Visual Structural Review (Contractor's Site Audit) of Existing Conditions.

The site auditor should verify the following:

6. No visually apparent disallowed rafter holes, notches and truss modifications as shown above.
7. No visually apparent structural decay or un-repaired fire damage.
8. Roof sag, measured in inches, is not more than the rafter or ridge beam length in feet divided by 20.

Rafters that fail the above criteria should not be used to support solar arrays unless they are first strengthened.

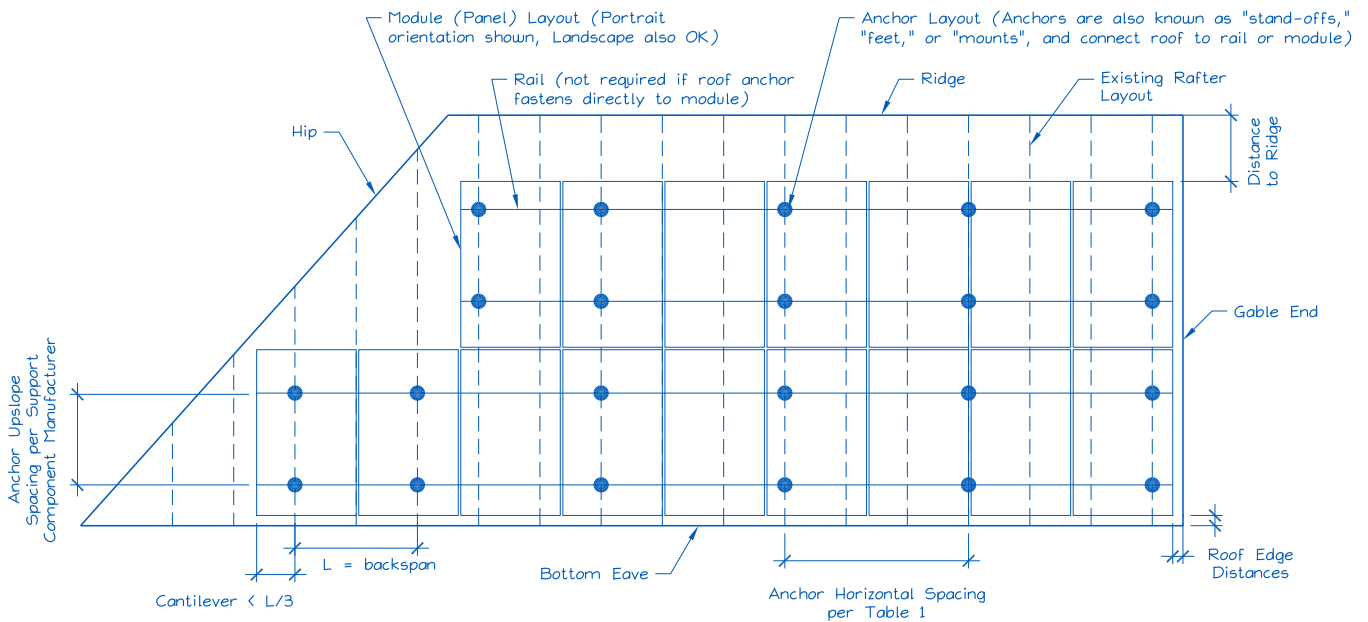

Figure 2. Sample Solar Panel Array and Anchor Layout Diagram (Roof Plan).

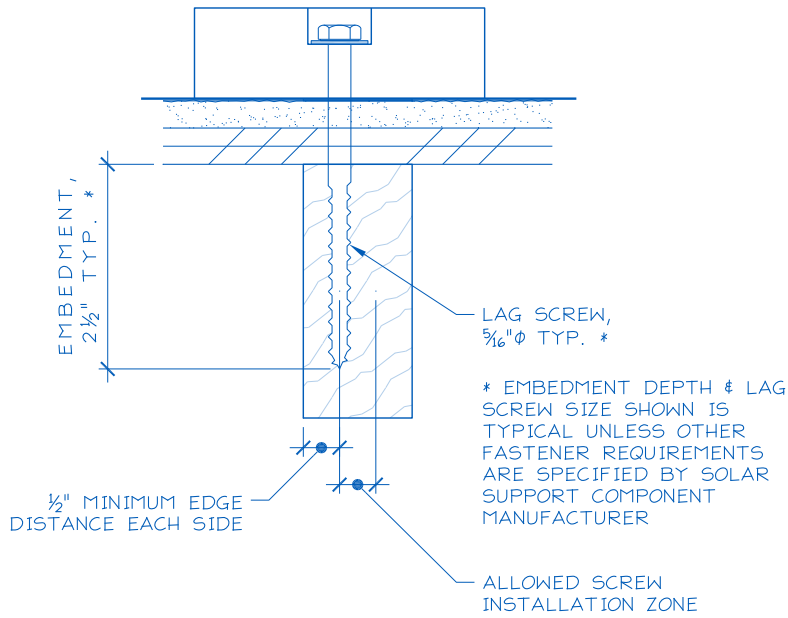
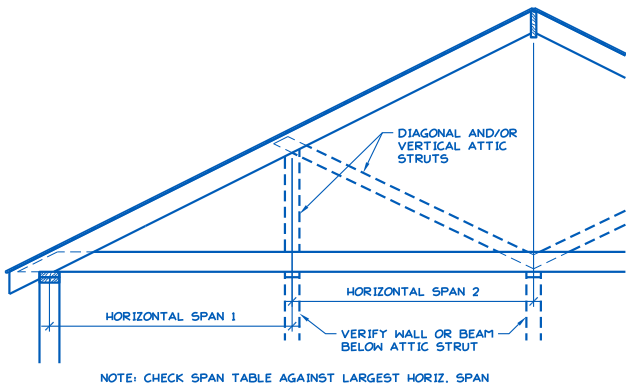
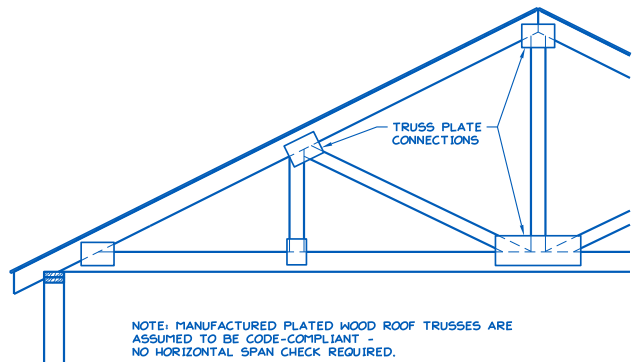

Figure 3. Typical Anchor with Lag Screw Attachment.



C STRUTS TO WALLS BELOW



D MANUFACTURED PLATED WOOD ROOF TRUSS

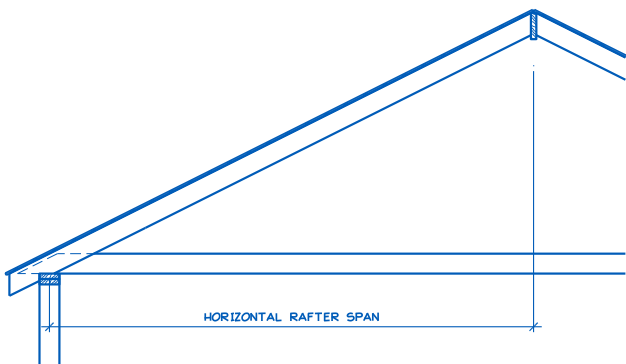

A SIMPLE ATTIC

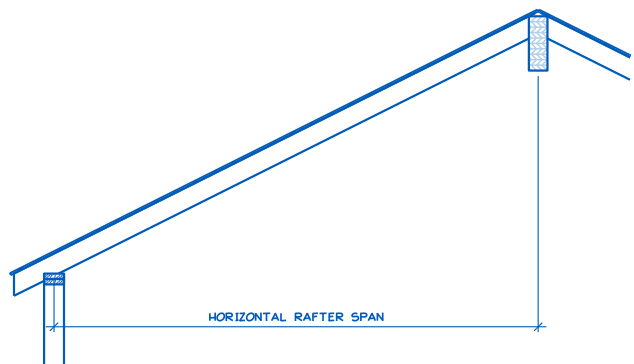

B CATHEDRAL CEILING

Figure 4. Definition of Rafter Horizontal Span.



CITY OF SONOMA - TOOLKIT DOCUMENT #7a

Inspection Guide for Solar Domestic Water Heating Systems in One- and Two-Family Dwellings

This document is a field inspection guide for Solar Domestic Water Heating systems. These inspection references detail most of the issues that relate to Solar Domestic Water Heating systems during the inspection process.

All California Electrical Code (CEC), California Residential Code (CRC), California Building Code (CBC), California Mechanical Code (CMC) and California Plumbing Code (CPC) references are to the 2016 versions unless otherwise noted.

SOLAR DOMESTIC WATER HEATING SYSTEM ELIGIBILITY			
SYSTEM	Criteria		Yes
		1. Major components installed match those of certified system?	
SOLAR DOMESTIC WATER HEATING INSPECTION GUIDE			
	Guideline	Source of Guideline	Yes
ROOF	I. Roof penetrations/attachments are properly flashed	CBC Chap. 15, CRC Chap. 9	
SOLAR LOOP PIPING	I. Piping must be properly supported, hung and anchored per code	CPC 313.1	
	II. Solar piping properly insulated	CPC 609.11	
	III. Dissimilar materials isolated, as required	CPC 310.6	
	IV. Penetrations through structural members as per code	CPC 312.2	
	V. Penetrations through fire-resistant assemblies installed per code	CPC 1405.2	
	VI. System has adequate freeze protection	CPC 312.6	
	VII. System overheat protection	CPC 505.2	
	VIII. Expansion tank sized correctly (indirect system) according to need for operation or overheat protection?	CPC 608.3, CMC 1005.3, 1005.4	
	IX. Pressure relief/temperature relief valve(s) installed per design (if applicable)	CPC 608.3 & 608.4	
	X. Piping labels show type of fluid and direction of flow	CPC 601.3	
	XI. Drain and fill valves capped and labeled	CPC 601.3	

SOLAR DOMESTIC WATER HEATING INSPECTION GUIDE

	Guideline	Source of Guideline	Yes
STORAGE TANK	I. Tank labeled with pressure rating for pressurized storage	CPC 505.4	
	II. Relief drain installed properly for pressurized storage	CPC 504.6, CMC 1006.1	
	III. Heat exchanger must protect potable water system from being contaminated by the heat transfer medium	CPC 603.4.5	
	IV. Tank installed in garage meets code requirements	CPC 507.13	
	V. Pan installed under tank (as required)	CPC 507.5	
	VI. Tank installed on level surface	CPC 508.4	
	VII. Tank supported for seismic loads	CPC 507.2	
	VIII. All valves, fittings and solders are rated for potable systems and meeting CA lead law requirements	CPC 604.1	
	IX. Unions installed within 12" of tank connections for all piping to and from tank and heat exchangers	CPC 609.5	
POTABLE PIPING	I. All valves, fittings and solders are rated for potable systems and meeting CA lead law requirements	CPC 604.1	
	II. Potable water piping properly labeled	CPC 601.2	
	III. Any connection to PEX is more than 18" from tank fittings	CPC 604.13	
	IV. Hot water service piping insulated properly	CPC 609.11	
	V. Vacuum relief valve properly installed (if required)	CPC 603.5. and 608.7	
CONTROLS	I. Control and pump disconnect(s) properly installed	CEC 430 (IX)	
	II. Conductors between control and power source properly installed	CEC 430 (II)	
	III. Conductors between control and pump properly installed	CEC 430 (II)	
	IV. Solar collector sensors protected from sun and weather	CEC 310.10D	
	V. Control relay rated higher than load for each output	CEC 430.83	
OTHER	I. Smoke & Carbon Monoxide Alarms are provided in the residence in accordance with Sections of the California Residential Code.	CRC R314 and R315	
	II. Rafters are sized and able to support the imposed loads. The supporting roof framing must comply with the requirements set forth in the Structural Criteria for Expedited Solar Permits (Toolkit #5) and in accordance with any site specific approved structural design.	CRC R802	