



June 14, 2018

Wendy Atkins
City of Sonoma, Planning Dept.
No. 1 the Plaza
Sonoma, CA

RE: Verizon Wireless Small Cell "Sonoma 012" on a new replacement Utility Pole in front of 574 1st St W.
(Northeast Corner of 1st ST W. & McDonnell)

Dear Wendy:

On behalf of Verizon Wireless, this letter provides information and an enhanced description to support the application's request to receive Design Review Approval to install a wireless telecommunications small cell node in the public right-of-way near the referenced location.

The following is a detailed **Project Description** of the facility design, the project's purpose, and justifications to find support of the application.

Project Purpose:

The purpose of this project is to provide improved wireless voice and data coverage to the surrounding area. These wireless services include mobile telephone, wireless broadband, emergency 911, data transfers, electronic mail, Internet, web browsing, wireless applications, wireless mapping, and video streaming. Further radio frequency details are set forth in the attached Radio Frequency Statement, including propagation maps depicting existing and proposed coverage in the vicinity.

Small Cell network consists of a radio access node connected to small telecommunications antenna(s), typically mounted on existing wooden utility poles within the public rights-of-way, to distribute wireless telecommunications signals. Small cells provide telecommunications transmission infrastructure for use by wireless services providers.

Our proposal application will greatly benefit the area by improving wireless telecommunications service as further detailed below.

Location:

Verizon Wireless is proposing to install a small cell network in Sonoma on 246 E. Napa St. A small cell network is a set of radio access nodes that deliver wireless signals throughout a given area. Small antennas and remote radio units are located at each node site, and the nodes are linked by fiber optic cable to a central equipment hub. The proposed small cell network consists of several nodes spaced evenly about the service area described above.

All the proposed nodes would be located on existing wooden utility poles in City of Sonoma. Verizon Wireless is the applicant and owner of the proposed small cell network and has rights, as CPUC member, to locate on existing utility poles.

The proposed location for this site currently consists of an approximately 43-foot-tall wooden utility pole located in the public right-of-way on the northeast corner of 1st Street and McDonnell at 574 1st St W., in Sonoma. Verizon would be adding equipment on the pole.

Scope of Work:

JUN 14 2018

- Install (1)(N) canister antenna mounted on (N) replacement utility pole.
- Install (3)(N) RRU-units on (N) replacement pole.
- Install (N) FFC signage on (N) replacement pole.
- Install (N) ground rods and buss bar.
- Install (2)(N) utility disconnect switches on (N) replacement pole.
- Install (1) electrical meter on (N) replacement pole
- Install (3)(N) conduits for power, telco, and coax

Antenna:

The antennas are cylindrical in shape and of the canister type, measuring 48 inches high and 14.6 inches in diameter. The antenna would be situated on top of the new pole, extending the overall structure height to 47.4 feet. The antennas would be painted dark brown to match the pole. The drawings and photographic simulations included with this application depict the design and its appearance on the pole.

Radio Units:

The radio units will be situated on the pole no higher than 14.1 feet at their tip, and painted dark brown to match the pole. The radio units are approximately 19.7 inches tall, 17.0 inches wide, and 7.2 inches deep and 27.2 inches tall, 12.1 inches wide and 7.0 inches deep. These units serve to run the equipment that interfaces with the Verizon Wireless communications network.

Additional Comments:

Verizon is siting in your city as this is an area where the demand and concentration are highest. We evaluated many locations before deciding on this one. This site was carefully selected based on this network's maturity, unique coverage and capacity needs. Verizon's placement of cellular facilities also depends on often limited availability of property where the facilities can be built and operated. Moving the site even a few hundred feet could affect coverage, creating the need for one or more additional sites. An alternative Site Analysis is included in the resubmittal application to show the alternatives considered and to help demonstrate support for the selected proposed node location. Note below is further information to support improvements in residential neighbors.

Justification:

As the community's demands for data area are increasing exponentially, we are required to go more closely into the areas where people use their phones, such as neighborhoods, urban areas, and commercial complexes. Centrally located sites provide the best capacity for the most people in a given community. Alternate candidates were assessed to find the best possible option that met the coverage objective and aesthetics. See Alternative Siting Analysis for these alternate considerations. In turn, Verizon Wireless will be siting additional facilities because it is determined, based on demand, usage, and service reports, that there is a need for increased capacity to meet the growing demand.

This site will increase the bandwidth needed to access data-rich applications like video and internet streaming, uploading and downloading photos and video, applications in the area to serve existing customers, and future wireless needs. Please note that as a part of the application, Verizon Wireless has provided Coverage Maps to support this need even though California Public Utilities Code section 7901 grants wireless providers the right to place wireless facilities along public rights-of-way without a lease or license.

Reservation of Rights:

Verizon has sited their equipment in the city's Public Right of Way, which makes space available for utilities to install their equipment, be it in residential, commercial, or industrial areas. To assist Planning to better lend project support

and recommendation for approval, please find attached a copy of a brief description of utilities' rights. Italicized below is an excerpt:

California Public Utilities Code § 7901 grants a statewide franchise to telephone corporations such as Verizon Wireless to place telephone equipment in the public rights-of-way, and the use of the rights-of-way by telephone corporations is a matter of statewide concern that is not subject to local regulation except where such use incommodes the public use of a road or highway.

Site Selection:

We evaluated many sites before choosing this one. This site was carefully selected based on this network's maturity, unique coverage, and capacity needs. Verizon's placement of cellular facilities also depends on often limited availability of property where the facilities can be built and operated. Moving the site even a few hundred feet could affect coverage, creating the need for one or more additional sites. An alternative Site Analysis was included in the application to show the alternatives considered and to help demonstrate support for the selected proposed node location.

Construction:

Once all required permits are received, the licensed General Contractor will pick up the permit(s) and ensure that the City's Municipal Code requirements for construction in the Public Right of Way are met. Construction will take about a week with minimal disruption to the area.

Maintenance and Monitoring:

After the site construction is complete and the installation is operational, the installation will be an unmanned facility that requires occasional maintenance, about once a month or less, unless the equipment needs repair. All repair and installation work will comply with Department of Public Works City Requirements for conducting work in the public right of way. Also, all non-emergency work may be done during non-peak traffic hours to alleviate traffic congestion.

Safety Standards:

Please note that the Federal Communications Commission (FCC) sets safety guidelines for wireless facilities and due to the small size of this type of installation and it being low wattage, the emissions from small cells are a small fraction of FCC permitted levels in any publicly-accessible area. See FCC website for additional information at: <http://www.fcc.gov/oet/rfsafety/rf-faqs.html>. Included with our submittal is documentation from a 3rd party engineer stating how the proposed facility will comply with the FCC safety standards.

In conclusion, based on review of the above information and supporting documents included with our application, it is our hope we have provided substantial information to respectfully request Sonoma Planning support of the Project thereby recommend application approval. Sonoma Planning approval will enhance Verizon Wireless service in the area that will better serve Sonoma residences, visitors, and the emergency service providers who rely on the Verizon Wireless network.

If you have questions please feel free to contact me at 415-806-2323 or Christy@TheCBRGroup.com.

Sincerely,
The CBR Group, Inc.

Christy Beltran
(Authorized Agent for Verizon Wireless)

COMMUNITY BENEFITS

How Mobile Devices are Used Today

(Mobile Device: Cellular Phones, Tablets, etc..)

- 90% of American households use wireless service with approximately 52% being *wireless only* for telephone service. The average number of connected devices per home is 13.*
 - Homes are becoming increasingly reliant on their wireless networks for internet usage, voice, data, text, and media streaming,
- Cellular service and home technology capabilities is of major importance to homebuyers. Ranking higher than schools, 76% versus 60%.*
- Global mobile data traffic will increase sevenfold between 2016 and 2021, growing at a compound annual growth rate (CAGR) of 47% from 2016 to 2021. Reaching 49.0 Exabyte's per month by 2021.*

Small Cells help networks deliver best in class speeds, coverage, capacity and reliability.

*Source: Cisco Visual Networking Index: Global Mobile Data Traffic Forecast Update, 2016–2021 White Paper (2-17-17)

PUBLIC SAFETY AND THE COMMUNITY

82% of 911 Calls Originate from a Cell Phone

- ✓ Enhanced network improvements to enable streaming and quick internet access to receive reliable information quickly regarding:
 - Fires, floods, earthquakes, mudslides, etc....
 - Be quickly and reliably informed about neighborhoods where loved ones and family are located.
- ✓ Enhanced capacity for **Reverse 911** allows emergency officials to notify residents and businesses of an emergency and actions they may need to take.
- ✓ Many First Responders rely on wireless services to conduct emergency and non-emergency communications.

Small Cell facilities support network advances and make communities safer.

SMART CITIES AND THE COMMUNITY

- Enhanced network serves as foundation **support** for smart cities infrastructure to:
 - ✓ Improve internal efficiency and reduce costs of public administration
 - ✓ Extend City services to citizens and improve public safety
 - ✓ IoT Devices (Internet of Things: smart meters, vital infrastructure, connected devices)
 - ✓ Support for autonomous cars
 - ✓ Ensure digital inclusion and spur economic development
- Small cell networks add capacity in a small specific areas to improve in-building coverage, voice quality, reliability, and data speeds for local residents, businesses, first responders, and visitors using the Verizon Wireless network.

Small Cell facilities proposed today are the roadmap for 5G and Smart City deployments

SMART CITIES AND THE COMMUNITY

Cisco Report on Wireless Data Usage

<https://www.cisco.com/c/en/us/solutions/collateral/service-provider/visual-networking-index-vni/mobile-white-paper-cl-520862.html>

PROPOSED SITE LOCATION



SITE COORDINATES

LATITUDE: 38.2906928
LONGITUDE: -122.4591328

Sonoma 012

574 1st Street West (Northeast corner of
1st Street West and McDonnell)
Sonoma, CA 95476
Location Code: 425102

SONOMA 012
Verizon Location Code: 425102



The CBR Group
841 Arnold Dr., Suite A
Martinez, CA 94553
info@thecbrgroup.com

JUN 14 2018

EXISTING



PROPOSED



PROPOSED WIRELESS ANTENNA

PROPOSED SUPPORT EQUIPMENT

Sonoma 012
 574 1st Street West (Northeast corner of
 1st Street West and McDonnell)
 Sonoma, CA 95476
 Location Code: 425102

**VIEW 1: LOOKING NORTHEAST ACROSS
 1ST STREET WEST**
 PHOTOSIMS PRODUCED 6/13/2018



The CBR Group
 841 Arnold Dr., Suite A
 Martinez, CA 94553
 info@thecbrgroup.com

EXISTING



PROPOSED



Sonoma 012
574 1st Street West (Northeast corner of
1st Street West and McDonnell)
Sonoma, CA 95476
Location Code: 425102

**VIEW 2: LOOKING EAST ACROSS
1ST STREET WEST**
PHOTOSIMS PRODUCED 6/13/2018



The CBR Group
841 Arnold Dr., Suite A
Martinez, CA 94553
info@thecbrgroup.com

EXISTING

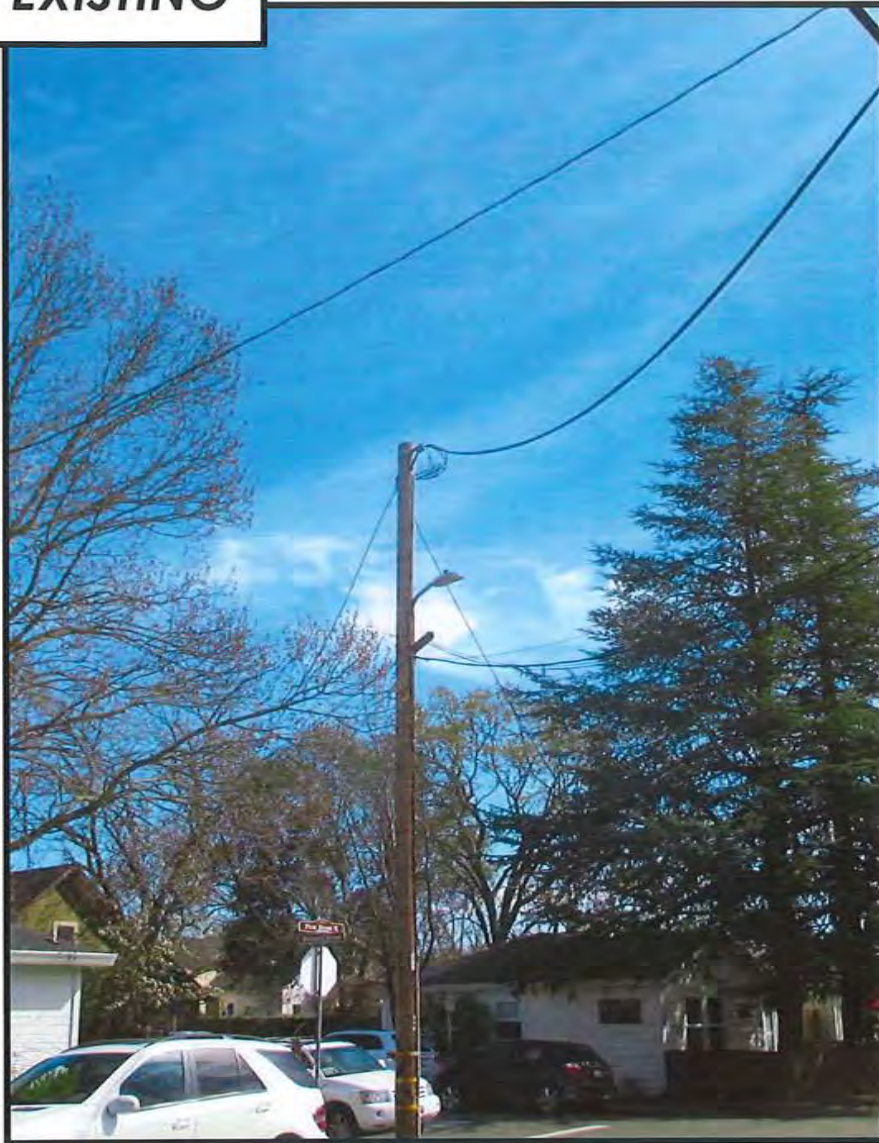

PROPOSED

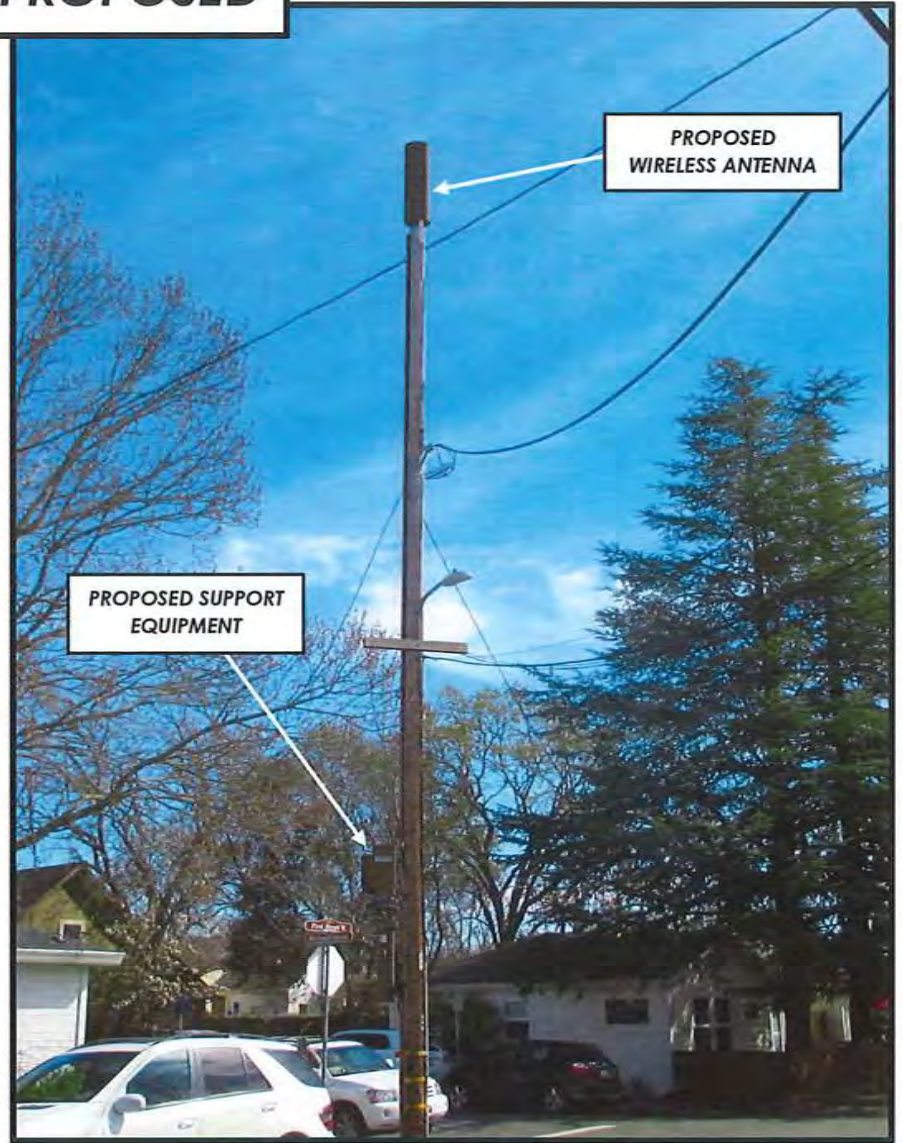

Sonoma 012
574 1st Street West (Northeast corner of
1st Street West and McDonnell)
Sonoma, CA 95476
Location Code: 425102

**VIEW 3: LOOKING SOUTHEAST ACROSS
1ST STREET WEST**
PHOTOSIMS PRODUCED 6/13/2018



The CBR Group
841 Arnold Dr., Suite A
Martinez, CA 94553
info@thecbrgroup.com

EXISTING



PROPOSED



Sonoma 012

574 1st Street West (Northeast corner of
1st Street West and McDonnel)
Sonoma, CA 95476
Location Code: 425102

**VIEW 4: LOOKING SOUTH ALONG
1ST STREET WEST**

PHOTOSIMS PRODUCED 6/13/2018



The CBR Group
841 Arnold Dr., Suite A
Martinez, CA 94553
info@thecbrgroup.com

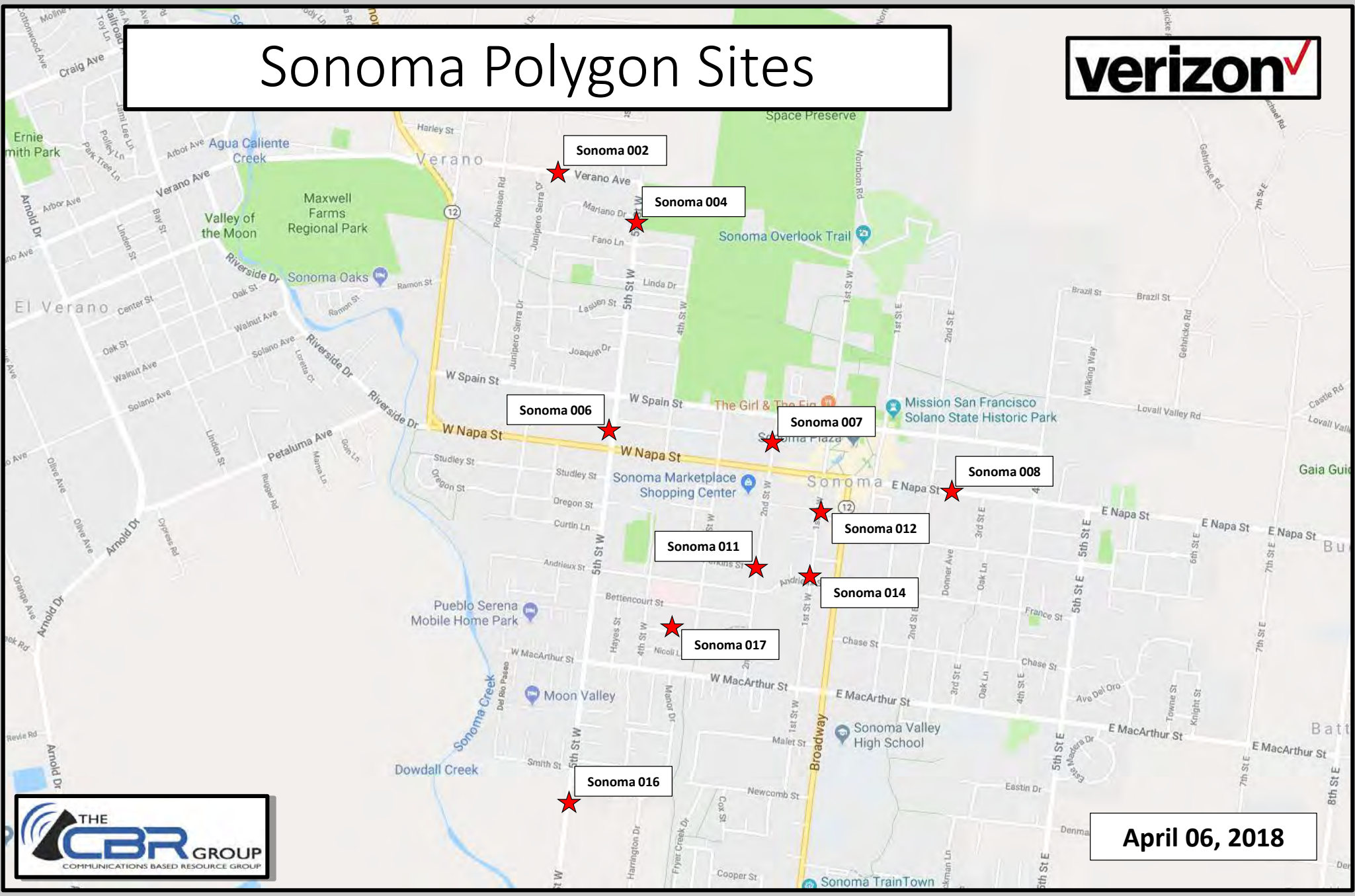

Sonoma Polygon Sites

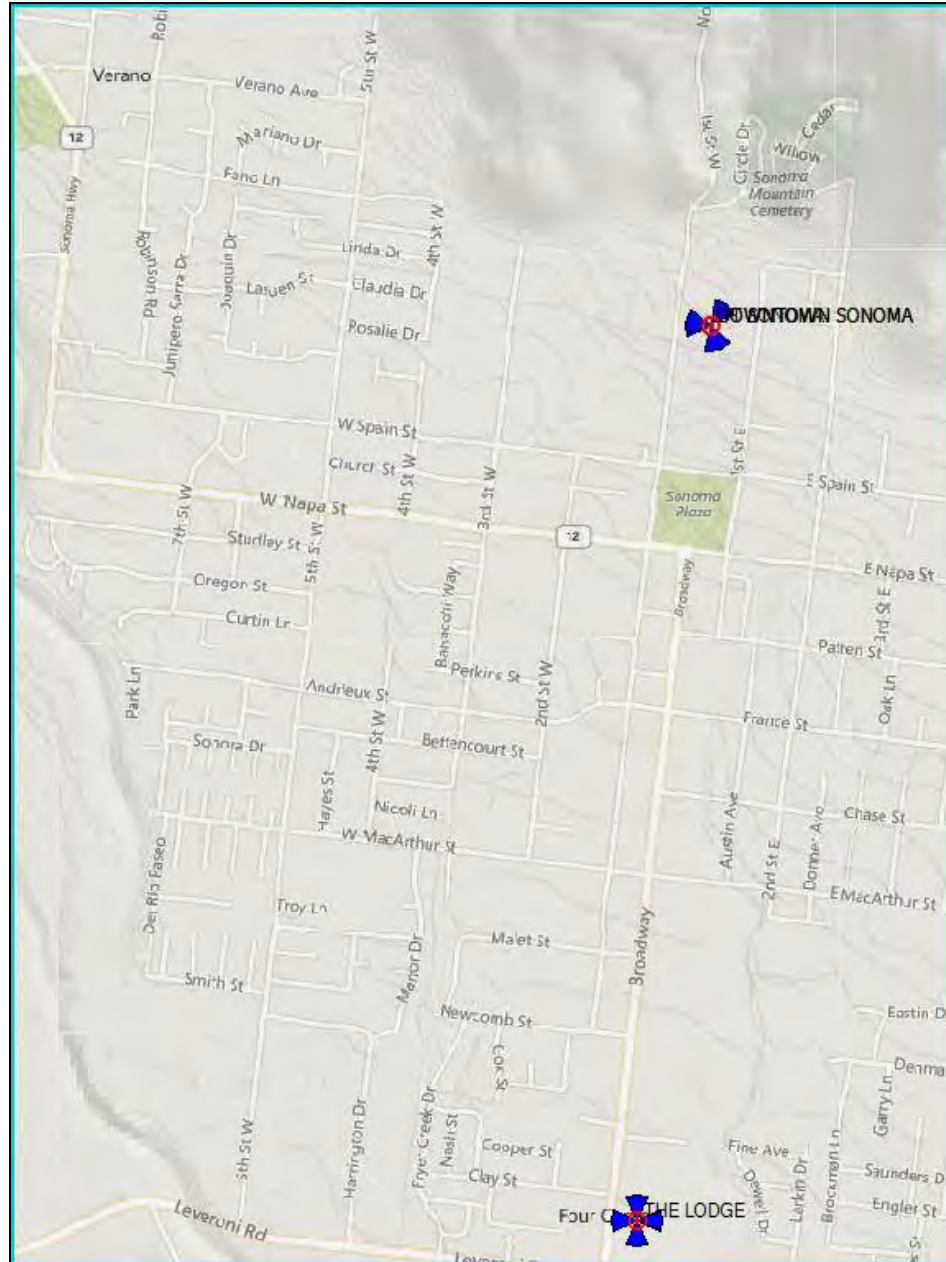

April 06, 2018

Coverage Area



	Current On Air
	Solutions in works

Without Small cell_ AWS Coverage

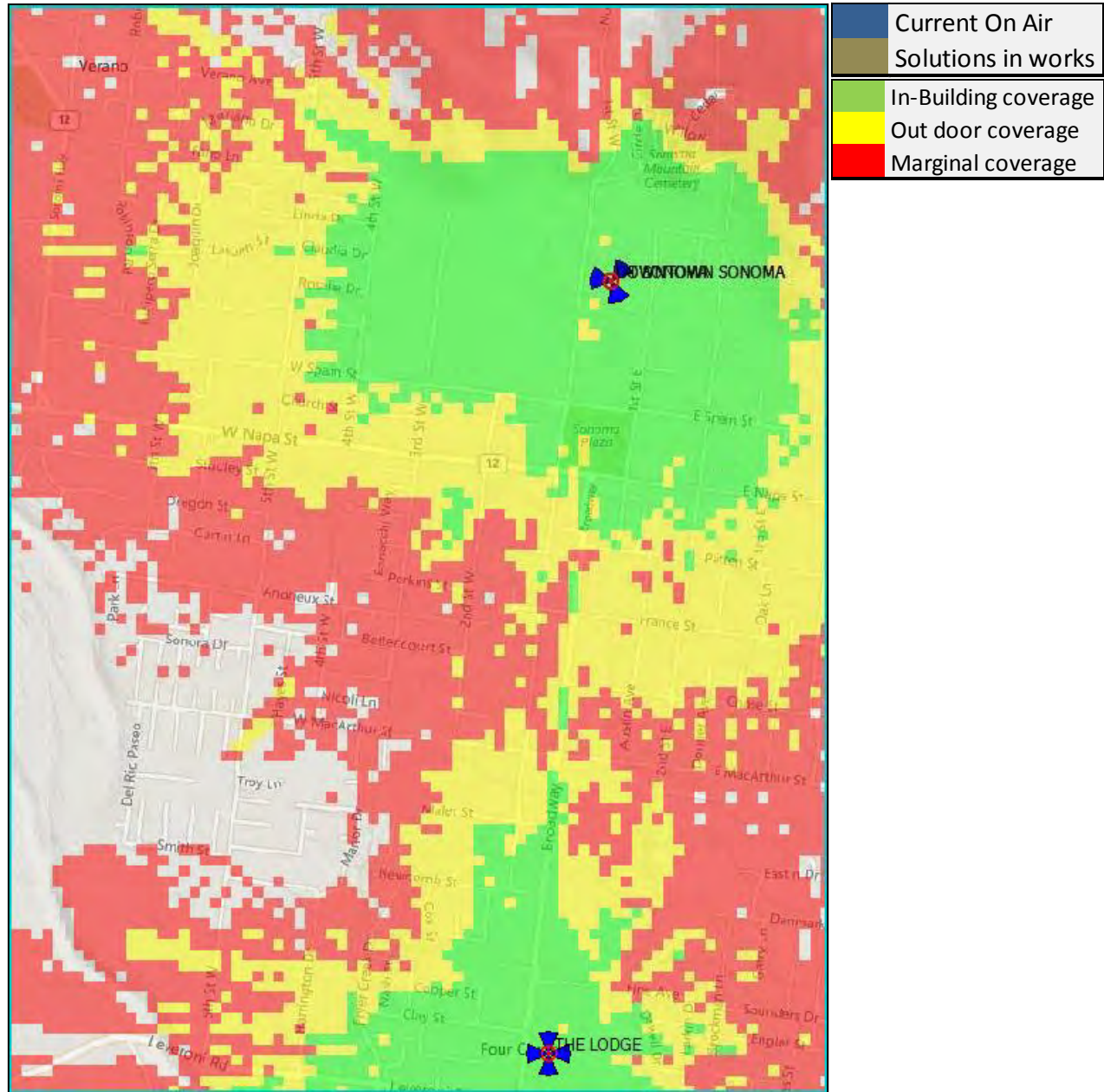

With Small cell_AWS_Coverage

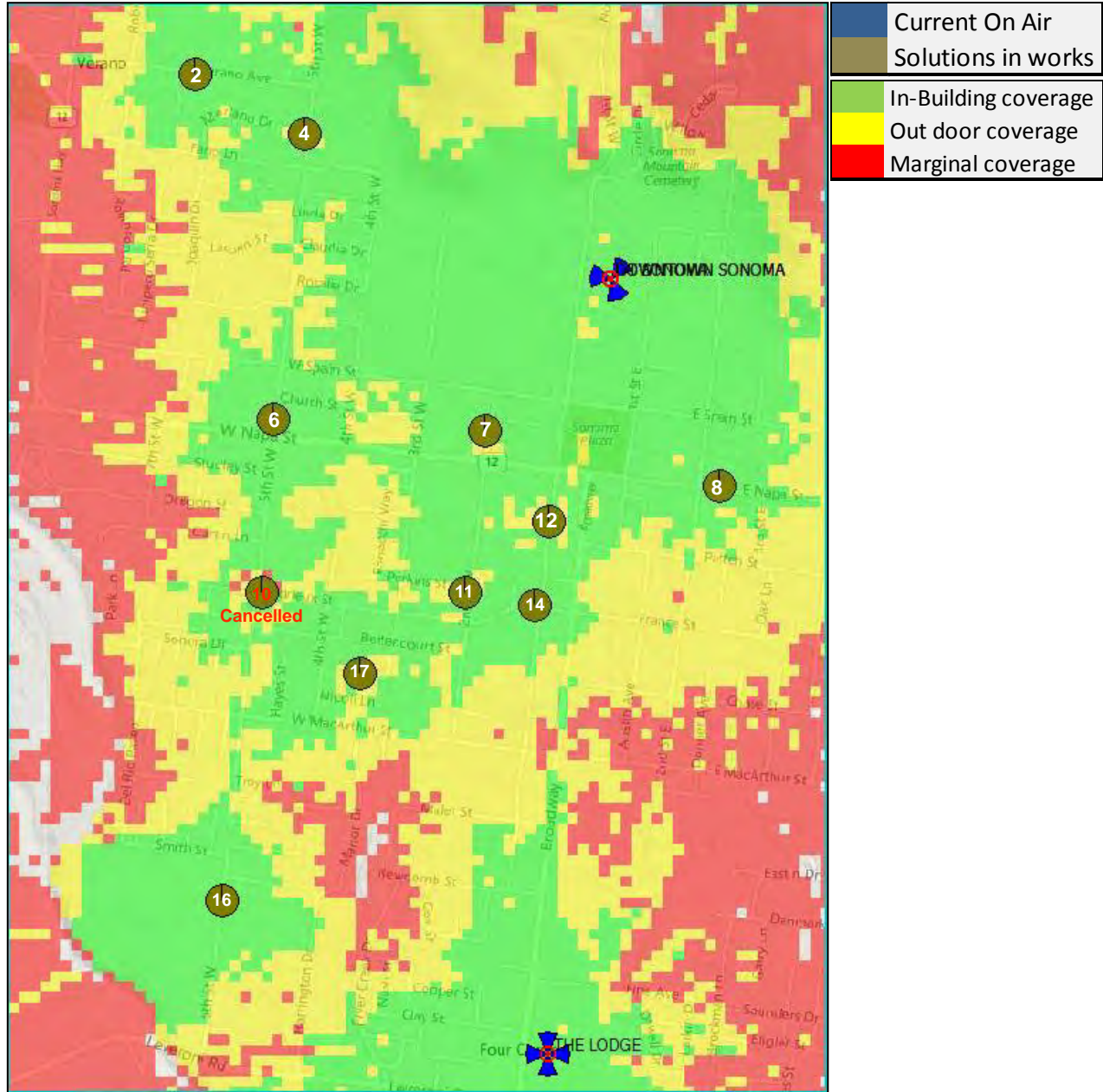



SONOMA 012

574 1st STREET WEST
(NORTHEAST CORNER OF
1ST STREET WEST AND MCDONNELL)
SONOMA, CA 95476
STRUCTURE TYPE: PG&E POLE TOP
LOCATION CODE: 425102
POLE #: 86

Prepared For:
verizon
2785 MITCHELL DRIVE, SUITE 9
WALNUT CREEK, CA 94598

Prepared For:

Site Number:
425102
Site Name:
SONOMA 012
Site Address:
574 1st STREET WEST
SONOMA CA 95476
County:
SONOMA COUNTY

Engineer:
THE CBR GROUP
841 ARNOLD DRIVE, SUITE A
MARTINEZ, CA 94553
www.TheCBRGroup.com



IT IS A VIOLATION OF LAW FOR ANY PERSON, UNLESS THEY ARE ACTING UNDER THE DIRECTION OF A LICENSED PROFESSIONAL ENGINEER, TO ALTER THIS DOCUMENT.

Issued For:
CONSTRUCTION

REV	DATE	DESCRIPTION	BY
D	06/12/18	REMOVE BBU	WM
C	03/13/18	PLANNING COMMENTS	JG
B	08/28/17	100% CD'S FOR REVIEW	GC
A	08/02/17	90% CD'S FOR REVIEW	WM

Sheet Title:
TITLE SHEET

Sheet Number:
T-1

JUN 14 2018

PROJECT DESCRIPTION

THIS IS AN UNMANNED WIRELESS TELECOMMUNICATION FACILITY FOR VERIZON WIRELESS SYSTEMS CONSISTING OF THE INSTALLATION AND OPERATION OF AN ANTENNA AND ASSOCIATED EQUIPMENT. SCOPE OF WORK CONSISTS OF THE FOLLOWING:

1. INSTALL (1) (N) CANISTER ANTENNA MOUNTED ON (N) 50' REPLACEMENT POLE (43'-0" ABOVE GROUND LEVEL, 7'-0" UNDERGROUND EMBEDMENT).
2. INSTALL (3) (N) RRU UNIT ON (N) UTILITY POLE.
3. INSTALL (2) (N) DISCONNECT SWITCHES ON (N) UTILITY POLE.
4. INSTALL (1) (N) ELECTRICAL METER ON (N) UTILITY POLE.
5. INSTALL (N) FCC SIGNAGE ON (N) UTILITY POLE.
6. INSTALL (N) GROUND RODS AND BUSS BAR.
7. INSTALL (3) (N) CONDUITS FOR POWER, TELCO AND COAX.

SITE COMPLETION CHECKLIST

- ANTENNAS, MOUNTING BRACKETS, POLE EXTENSIONS, PVC CONDUIT, CABLING, METER AND RADIO RELAY UNITS TO BE PAINTED USING A DURABLE PAINT (E.G. KELLY MOORE OR EQUIVALENT)
- CABLING TO BE INSTALLED IN A TIDY MANNER WITHOUT EXCESS CABLE LOOPS.
- SPACING OF SUPPORT ELEMENTS—SUPPORT EQUIPMENT (E.G. METER, LOAD CENTER AND RRU'S) TO BE CLUSTERED (VERTICALLY) AS CLOSE AS IS TECHNICALLY FEASIBLE ON POLE.
- FCC MANDATED RF WARNING SIGNAGE SHALL FACE OUT TO STREET WHEN PLACED IN FRONT OF, OR NEAR A WINDOW. SIGNAGE SHALL FACE TOWARD BUILDING IF THERE IS NO WINDOW.
- PROPOSED UTILITY ROUTES TO BE DETERMINED BY UTILITY PROVIDER.

- ### CODE COMPLIANCE
- ALL WORK AND MATERIALS SHALL BE PERFORMED AND INSTALLED IN ACCORDANCE WITH THE CURRENT EDITIONS OF THE FOLLOWING CODES AS ADOPTED BY THE LOCAL GOVERNING AUTHORITIES. NOTHING IN THESE PLANS IS TO BE CONSTRUED TO PERMIT WORK NOT CONFORMING TO THESE CODES.
- 1) 2016 CALIFORNIA BUILDING CODE (CBC) WITH CALIFORNIA AMENDMENTS, BASED ON THE 2009 IBC
 - 2) 2016 CALIFORNIA RESIDENTIAL CODE (CRC) WITH APPENDIX H, PATIO COVERS, BASED ON THE 2009 IRC
 - 3) 2016 CALIFORNIA HISTORICAL BUILDING CODE (CHBC)
 - 4) 2016 CALIFORNIA EXISTING BUILDING CODE (CEBC), BASED ON THE 2009 IEBC
 - 5) 2016 CALIFORNIA GREEN BUILDINGS STANDARDS CODE (CGBSC)
 - 6) 2016 CALIFORNIA FIRE CODE (CFC), BASED ON THE 2009 IFC, WITH CALIFORNIA AMENDMENTS
 - 7) 2016 CALIFORNIA MECHANICAL CODE (CMC), BASED ON THE 2009 UMC
 - 8) 2016 CALIFORNIA PLUMBING CODE (CPC), BASED ON THE 2009 UPC
 - 9) 2016 CALIFORNIA ELECTRICAL CODE (CEC) WITH CALIFORNIA AMENDMENTS, BASED ON THE 2008 NEC
 - 10) 2016 CALIFORNIA ENERGY CODE (CEC)
 - 11) ANSI / EIA-TIA-222-G
 - 12) 2015 NFPA 101, LIFE SAFETY CODE
 - 13) 2015 NFPA 72, NATIONAL FIRE ALARM CODE
 - 14) 2015 NFPA 13, FIRE SPRINKLER CODE
 - 15) G.O. 95

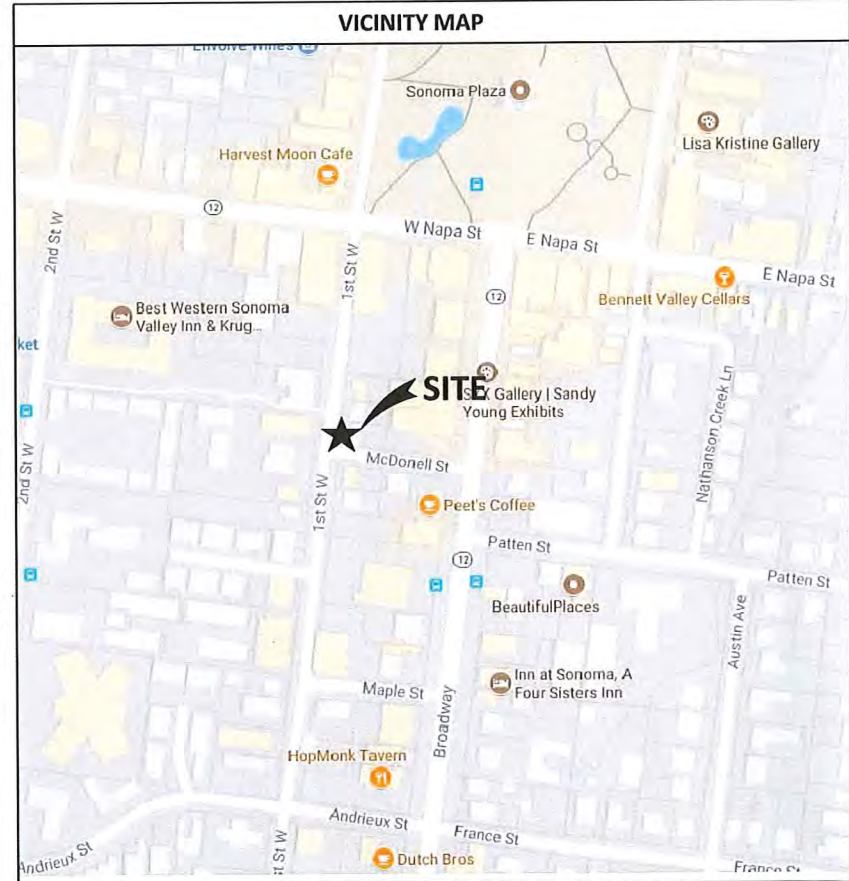

RADIO FREQUENCY DATA PLAN

REVISION LEVEL	DATE
-	xx/xx/xxxx

GENERAL CONTRACTOR NOTES

DO NOT SCALE DRAWINGS

THESE DRAWINGS ARE FORMATTED TO BE FULL SIZE AT 24" x 36". CONTRACTOR SHALL VERIFY ALL PLANS AND EXISTING DIMENSIONS AND CONDITIONS ON THE JOBSITE AND SHALL IMMEDIATELY NOTIFY THE ARCHITECT/ENGINEER IN WRITING OF ANY DISCREPANCIES BEFORE PROCEEDING WITH THE WORK OR MATERIAL ORDERS OR BE RESPONSIBLE FOR THE SAME.

PROJECT TEAM

APPLICANT/LESSEE:
VERIZON WIRELESS
2785 MITCHELL DRIVE, BLDG 9
WALNUT CREEK, CA 94598
CONTACT: SHARON MYL
PH: (914) 582-8356
EMAIL: sharon.myl@verizonwireless.com

SITE ACQUISITION MANAGER:
(APPLICANT / AGENT FOR VERIZON)
THE CBR GROUP
841 ARNOLD DRIVE, SUITE A
MARTINEZ, CA 94553
CONTACT: CHRISTY BELTRAN
PH: (415) 805-2323
EMAIL: christy@thebrgroup.com

CONSTRUCTION:
VERIZON WIRELESS
2785 MITCHELL DRIVE, BLDG 9
WALNUT CREEK, CA 94598
CONTACT: DENNIS RAINES
PH: (707) 514-5700
EMAIL: dennis@siteservicesllc.net

ENGINEER:
THE CBR GROUP
841 ARNOLD DRIVE, SUITE A
MARTINEZ, CA 94553
CONTACT: MATT FREEDMAN
PH: (925) 798-2100
EMAIL: matt@thebrgroup.com

RF ENGINEER:
VERIZON WIRELESS
2785 MITCHELL DRIVE, BLDG 9
WALNUT CREEK, CA 94598
CONTACT: BENJAMIN SANTA MARIA
PH: (925) 239-9186
EMAIL: benjamin.santamaria@verizonwireless.com

PROJECT INFORMATION

SITE INFORMATION:	POLE OWNER:
SITE NUMBER: 425102	PG&E
SITE NAME: SONOMA 012	POWER AGENCY:
SITE ADDRESS: 574 1ST ST. WEST SONOMA, CA 95476	PG&E 77 BEALE STREET SAN FRANCISCO, CA 94109 PH: (800) 743-5000
A.P.N. NUMBER: R.O.W	
CURRENT USE: UTILITY POLE AND CITY LIGHT	
PROPOSED USE: TELECOMMUNICATIONS FACILITY AND WOOD UTILITY POLE WITH CITY LIGHT	
JURISDICTION: CITY OF SONOMA	
LATITUDE: 38.2906928	
LONGITUDE: -122.4591328	
GROUND ELEVATION: 78.7± AMSL	

SHEET INDEX

T-1	TITLE SHEET	REV
1	SITE SURVEY (UTILITY POLE EXHIBIT)	D
A-1	OVERALL SITE PLAN	D
A-2	EXISTING AND PROPOSED EQUIPMENT AND ANTENNA PLANS	D
A-3	EXISTING AND PROPOSED SOUTH ELEVATION	D
A-4	EXISTING AND PROPOSED WEST ELEVATION	D
A-5	EQUIPMENT AND CONSTRUCTION DETAILS	D
A-6	EQUIPMENT AND CONSTRUCTION DETAILS	D
E-1	ELECTRICAL GROUND DIAGRAMS, SINGLE LINE DIAGRAM	D
E-2	ELECTRICAL DETAILS	D
TCP	TRAFFIC CONTROL PLAN	D

OCCUPANCY AND CONSTRUCTION TYPE

OCCUPANCY : S-2 (UNMANNED)
CONSTRUCTION TYPE: IIB

HANDICAP REQUIREMENTS
FACILITY IS UNMANNED AND NOT FOR HUMAN HABITATION, ACCESSIBILITY ACCESS AND REQUIREMENTS ARE NOT REQUIRED, IN ACCORDANCE WITH CALIFORNIA STATE ADMINISTRATIVE CODE, PART 2, TITLE 24, SECTION 1103B.1, EXCEPTION 1 & SECTION 1134B.2.1, EXCEPTION 4.

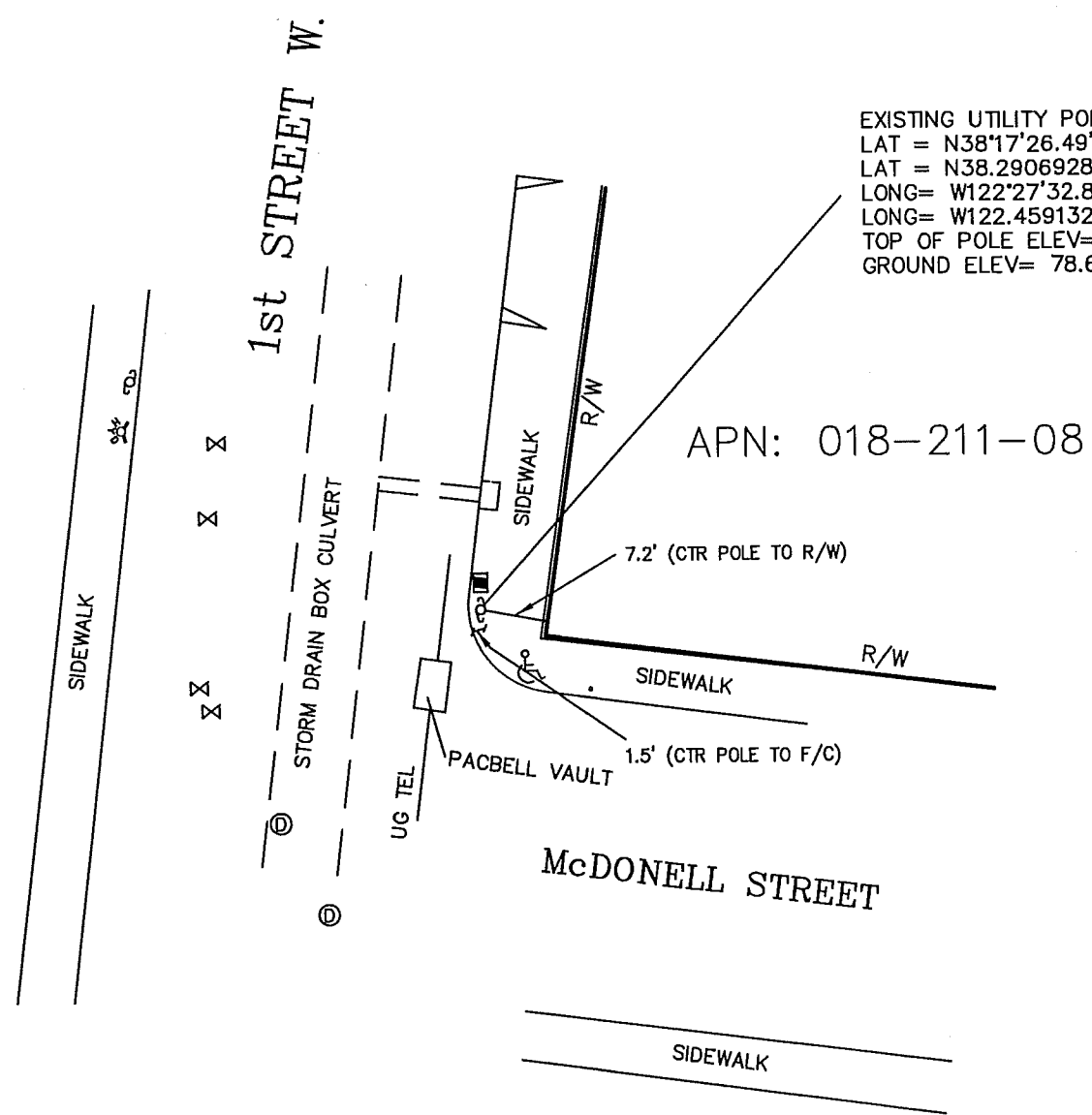

EXISTING UTILITY POLE
 LAT = N38°17'26.49" NAD83
 LAT = N38.2906928 NAD83
 LONG = W122°27'32.88" NAD83
 LONG = W122.4591328 NAD83
 TOP OF POLE ELEV = 111.87' NAVD88
 GROUND ELEV = 78.69' NAVD88

APN: 018-211-08

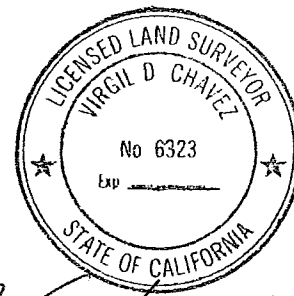
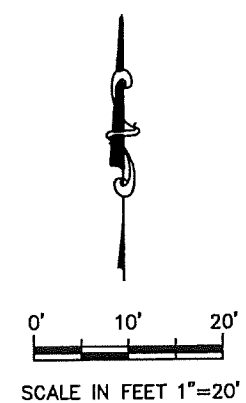

Virgil D. Chavez

LEGEND

- ⊕ - JPOLE
- ⊗ - WATER VALVE
- ⊙ - SANITARY SEWER MANHOLE
- ⊛ - FIRE HYDRANT
- ♿ - HANDICAP RAMP
- - WATER METER

DATE:	JULY, 2017		
DRAWN BY:	G.ESQ		
SCALE:	1" = 20'		
CHECKED:	VC		
PROJ. MGR:	VC	DC FILE:	365900
PROJ. NO.	365900	CAD FILE:	365900

UTILITY POLE EXHIBIT
 SITE (012)
 LOCATION CODE: 425102
 SONOMA, CA

VIRGIL CHAVEZ LAND SURVEYING
 721 TUOLUMNE STREET, VALLEJO, CA. 94590
 PHONE: (707) 553-2476

SHEET NO.
 1
 OF
 1 SHEETS

- 2 GRID REFERENCE
- 1 DETAIL REFERENCE
- A-2 ELEVATION REFERENCE
- SECTION REFERENCE
- CENTERLINE
- PROPERTY/LEASE LINE
- MATCH LINE
- WORK POINT
- GROUND CONDUCTOR
- TELEPHONE CONDUIT
- ELECTRICAL CONDUIT
- COAXIAL CABLE
- OVERHEAD SERVICE CONDUCTORS
- GROUT OR PLASTER
- (E) BRICK
- (E) MASONRY
- CONCRETE
- EARTH
- GRAVEL
- PLYWOOD
- SAND
- WOOD CONTINUOUS
- WOOD BLOCKING
- STEEL
- (N) NEW
- (E) EXISTING
- NEW ANTENNA
- EXISTING ANTENNA
- GROUND ROD
- GROUND BUS BAR
- MECHANICAL GRND. CONN.
- CADWELD
- GROUND ACCESS WELL
- ELECTRIC BOX
- TELEPHONE BOX
- LIGHT POLE
- FND. MONUMENT
- SPOT ELEVATION
- SET POINT
- REVISION

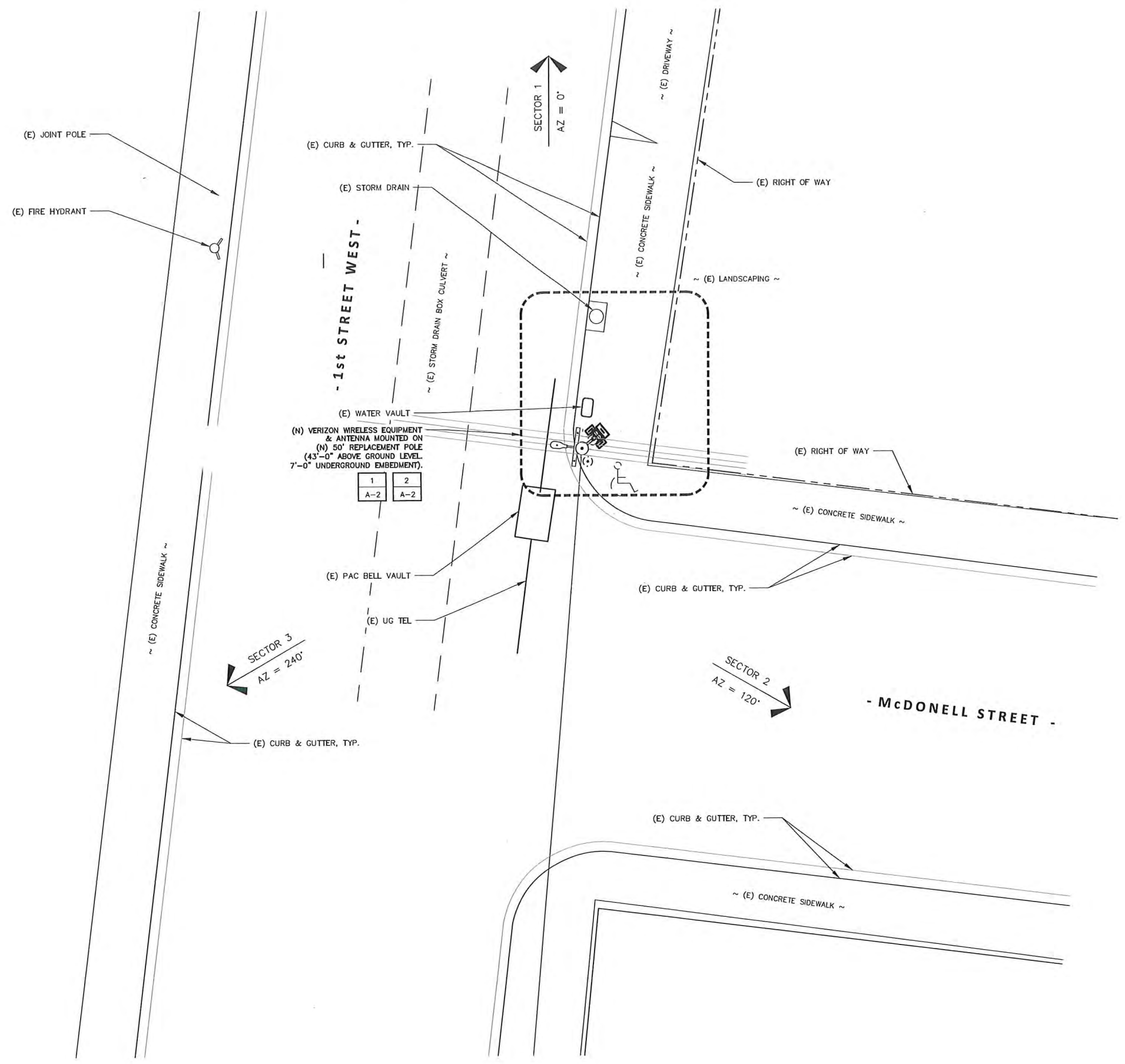
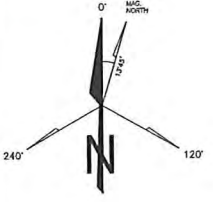

(N) VERIZON WIRELESS EQUIPMENT & ANTENNA MOUNTED ON (N) 50' REPLACEMENT POLE (43'-0" ABOVE GROUND LEVEL, 7'-0" UNDERGROUND EMBEDMENT).

1
A-2 2
A-2

2 SYMBOLS
N.T.S.

1 OVERALL SITE PLAN

SCALE: 3/16" = 1'-0"
0' 2' 4' 6' 12' 16'

Prepared For:
verizon
2785 MITCHELL DRIVE, SUITE 9
WALNUT CREEK, CA 94598

Prepared For:

Site Number:
425102
Site Name:
SONOMA 012
Site Address:
574 1st STREET WEST
SONOMA CA 95476
County:
SONOMA COUNTY

Engineer:
THE CBR GROUP
841 ARNOLD DRIVE, SUITE A
MARTINEZ, CA 94553
www.TheCBRGroup.com



IT IS A VIOLATION OF LAW FOR ANY PERSON, UNLESS THEY ARE ACTING UNDER THE DIRECTION OF A LICENSED PROFESSIONAL ENGINEER, TO ALTER THIS DOCUMENT.

Issued For:
CONSTRUCTION

REV	DATE	DESCRIPTION	BY
D	06/12/18	REMOVE BBU	WM
C	03/13/18	PLANNING COMMENTS	JG
B	08/28/17	100% CD'S FOR REVIEW	GC
A	08/02/17	90% CD'S FOR REVIEW	WM

Sheet Title:
OVERALL SITE PLAN

Sheet Number:
A-1

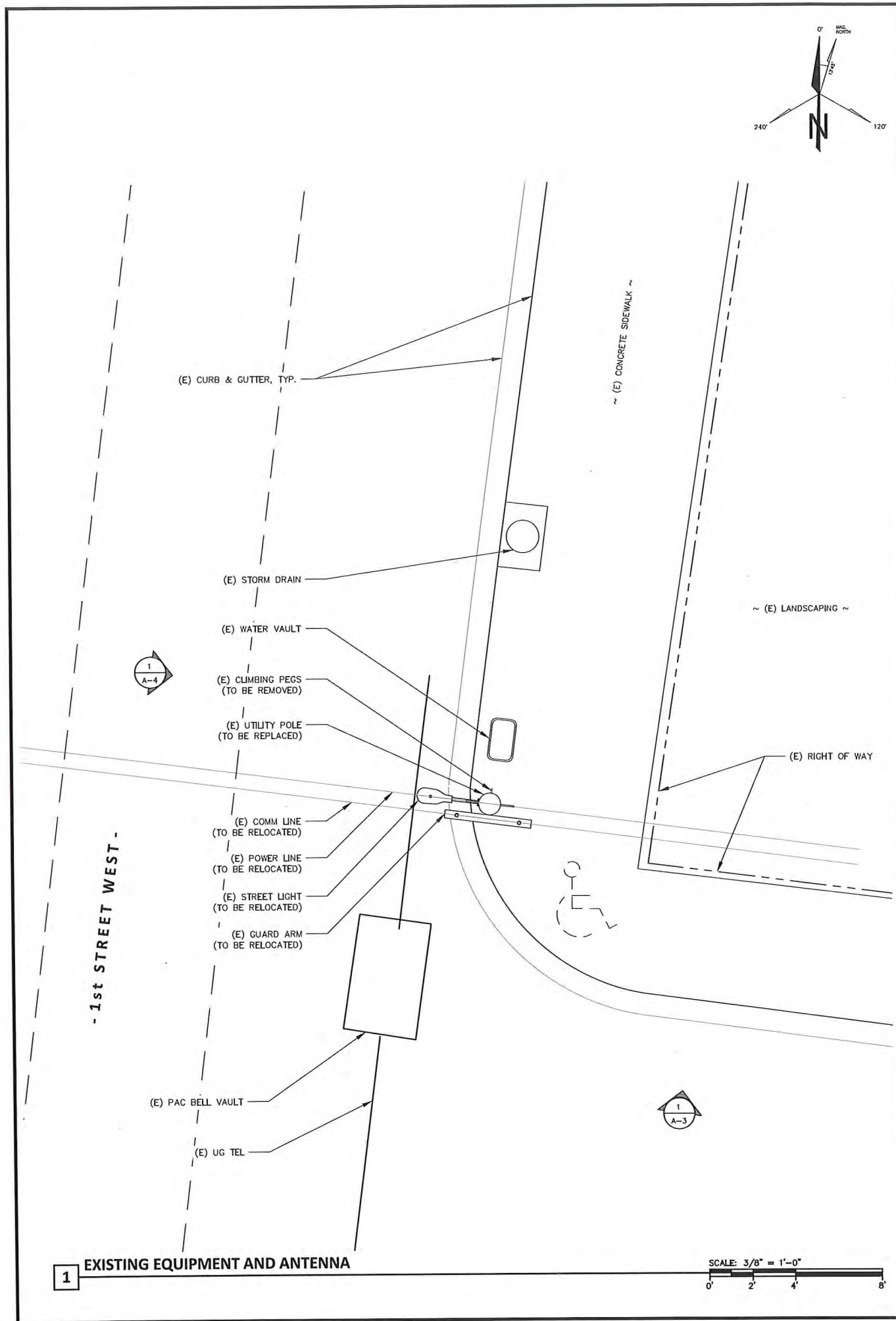

1 EXISTING EQUIPMENT AND ANTENNA

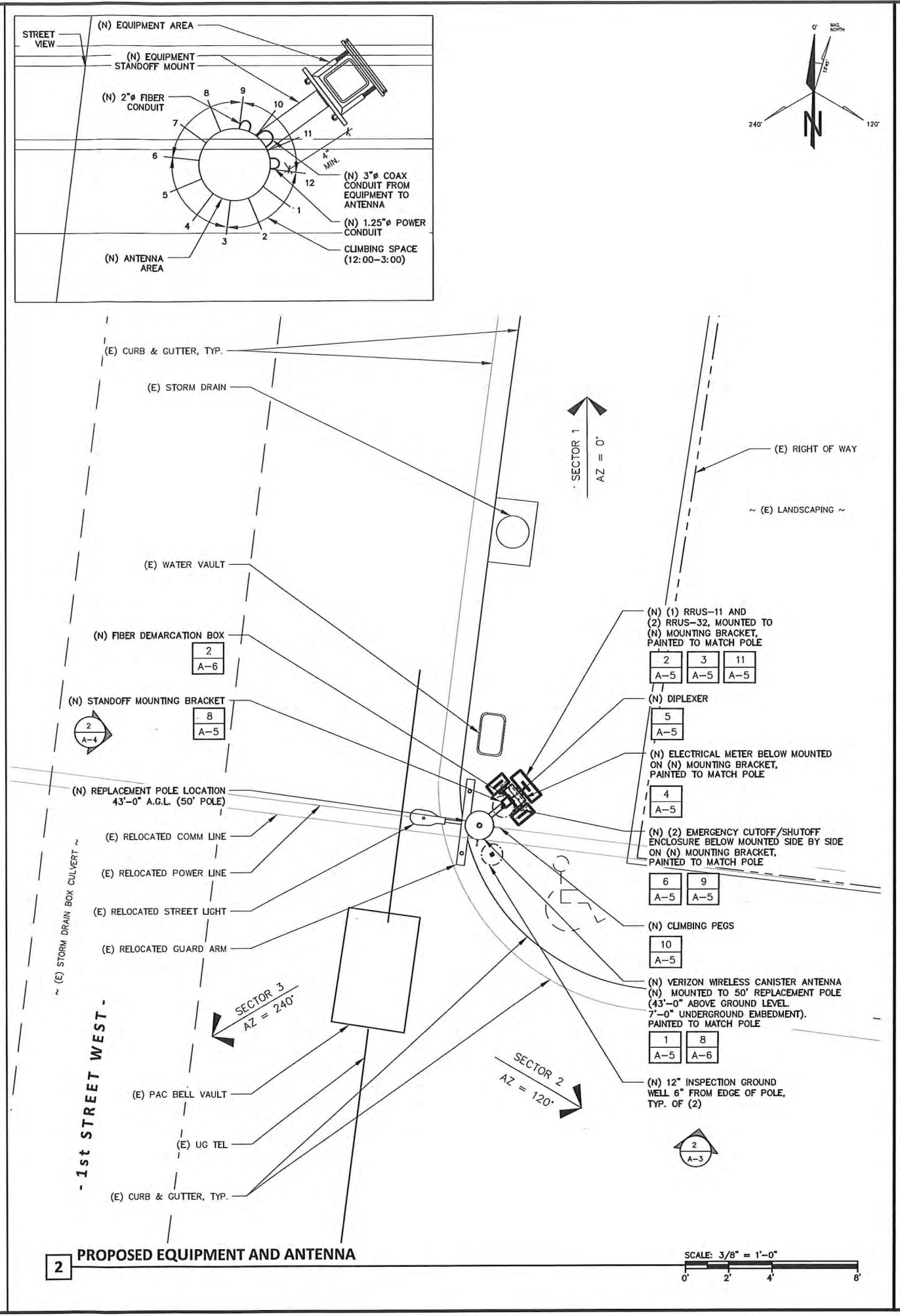
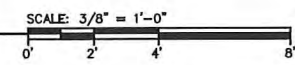

2 PROPOSED EQUIPMENT AND ANTENNA

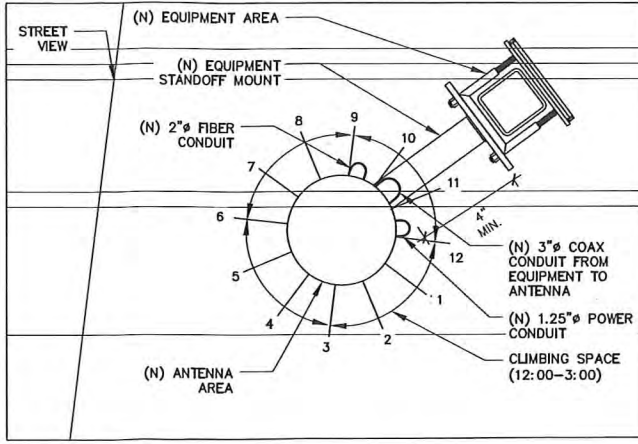
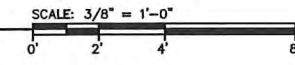

Prepared For:
verizon
 2785 MITCHELL DRIVE, SUITE 9
 WALNUT CREEK, CA 94598

Prepared For:

Site Number:
425102
 Site Name:
SONOMA 012
 Site Address:
574 1st STREET WEST
SONOMA CA 95476
 County:
SONOMA COUNTY

Engineer:
THE CBR GROUP
 841 ARNOLD DRIVE, SUITE A
 MARTINEZ, CA 94553
 www.TheCBRGroup.com

Licensor:

 REGISTERED PROFESSIONAL ENGINEER
 No C-86844
 Exp. 3/31/19
 CIVIL
 STATE OF CALIFORNIA

IT IS A VIOLATION OF LAW FOR ANY PERSON, UNLESS THEY ARE ACTING UNDER THE DIRECTION OF A LICENSED PROFESSIONAL ENGINEER, TO ALTER THIS DOCUMENT.

Issued For:
CONSTRUCTION

REV	DATE	DESCRIPTION	BY
D	06/12/18	REMOVE BBU	WM
C	03/13/18	PLANNING COMMENTS	JG
B	08/28/17	100% CD'S FOR REVIEW	GC
A	08/02/17	90% CD'S FOR REVIEW	WM

Sheet Title:
EXISTING AND PROPOSED EQUIPMENT AND ANTENNA PLANS

Sheet Number:
A-2

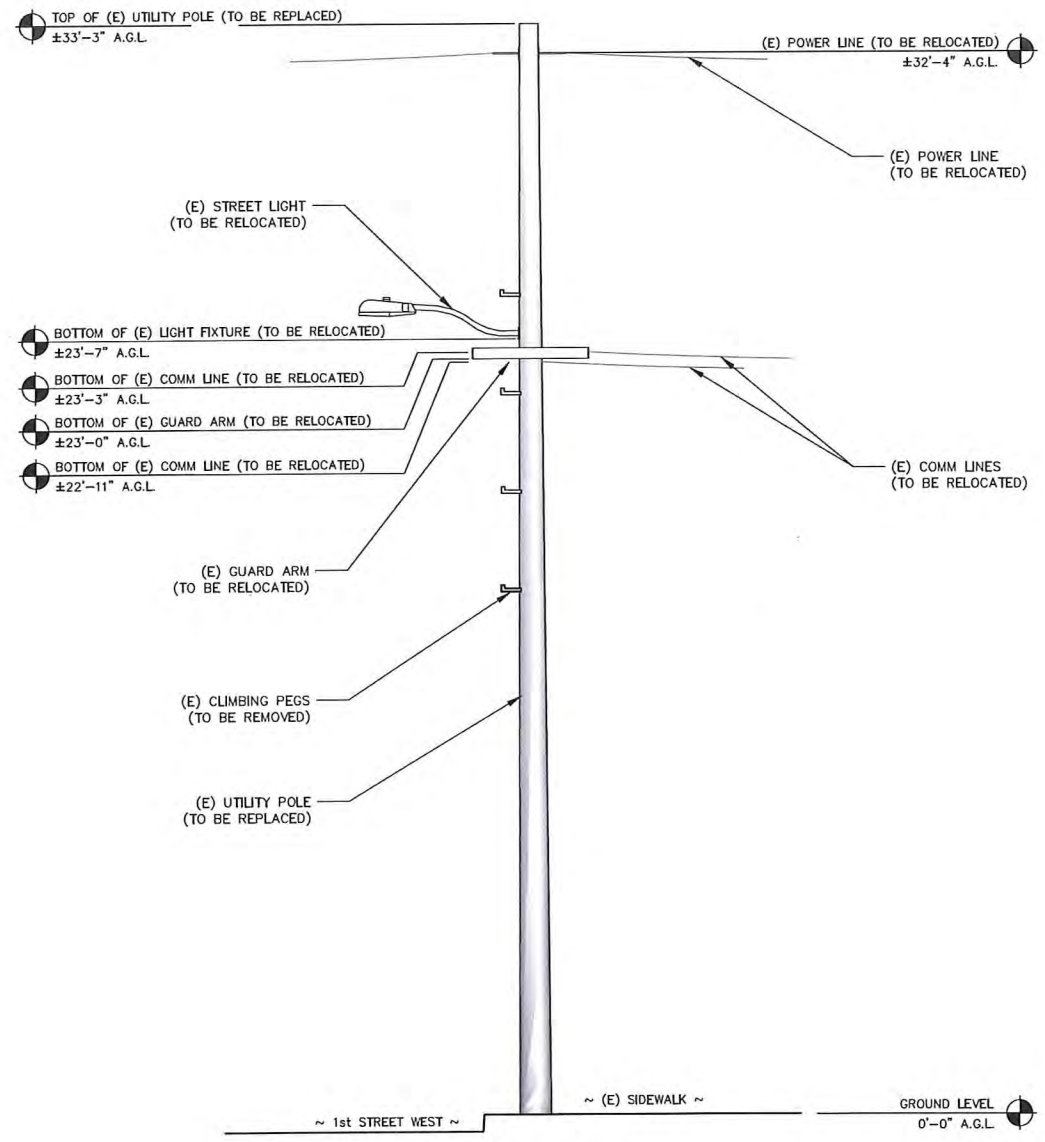

1 EXISTING SOUTH ELEVATION

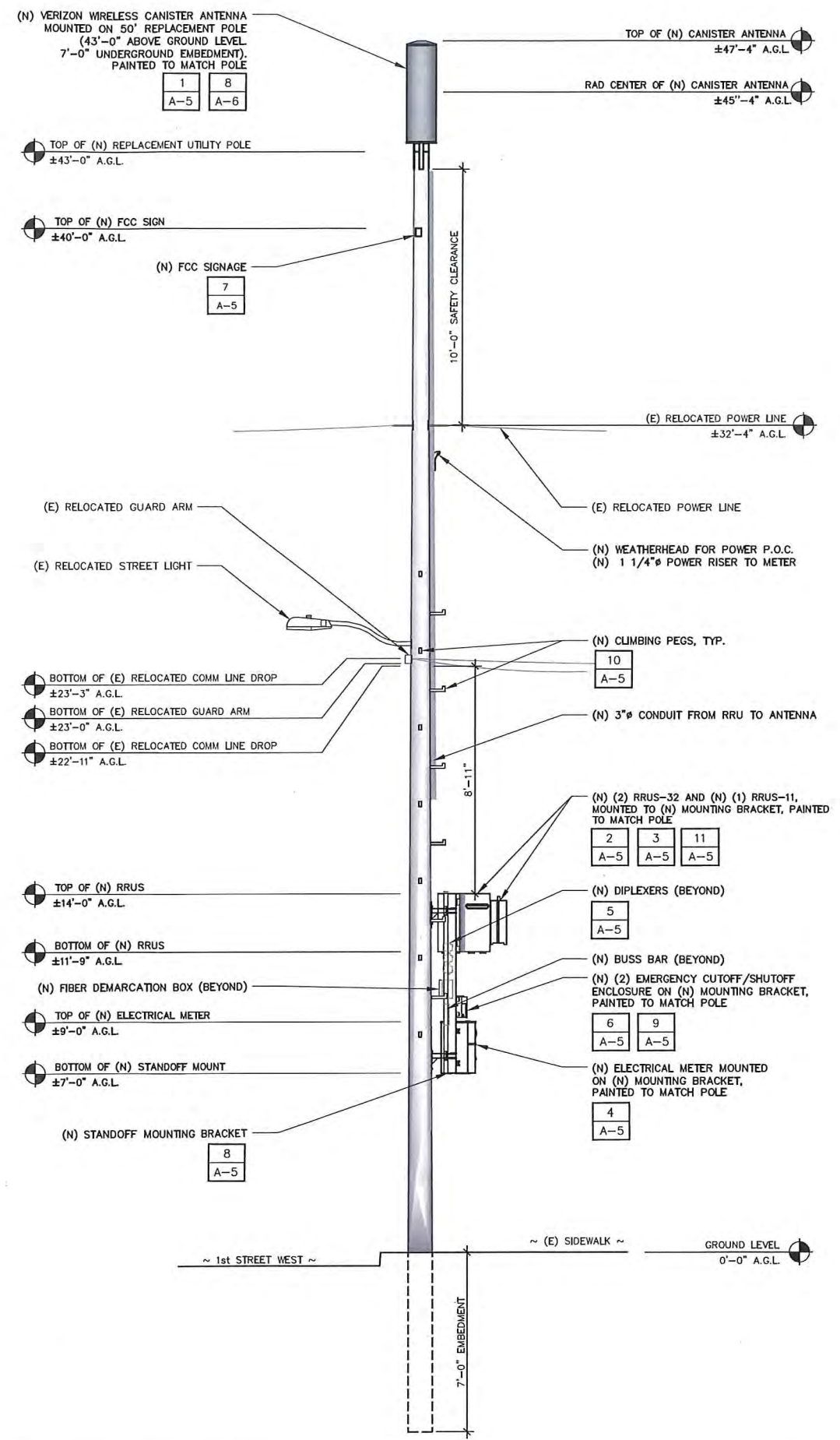
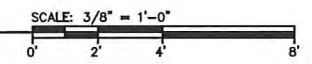

2 PROPOSED SOUTH ELEVATION

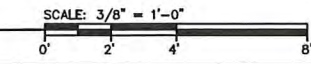

Prepared For:
verizon
 2785 MITCHELL DRIVE, SUITE 9
 WALNUT CREEK, CA 94598

Prepared For:

Site Number:
 425102
 Site Name:
 SONOMA 012
 Site Address:
 574 1st STREET WEST
 SONOMA CA 95476
 County:
 SONOMA COUNTY

Engineer:

 841 ARNOLD DRIVE, SUITE A
 MARTINEZ, CA 94553
 www.TheCBRGroup.com

Licenser:

IT IS A VIOLATION OF LAW FOR ANY PERSON, UNLESS THEY ARE ACTING UNDER THE DIRECTION OF A LICENSED PROFESSIONAL ENGINEER, TO ALTER THIS DOCUMENT.

Issued For:
 CONSTRUCTION

REV	DATE	DESCRIPTION	BY
D	06/12/18	REMOVE BBU	WM
C	03/13/18	PLANNING COMMENTS	JG
B	08/28/17	100% CD'S FOR REVIEW	GC
A	08/02/17	90% CD'S FOR REVIEW	WM

Sheet Title:
 EXISTING AND PROPOSED
 SOUTH ELEVATIONS

Sheet Number:
A-3

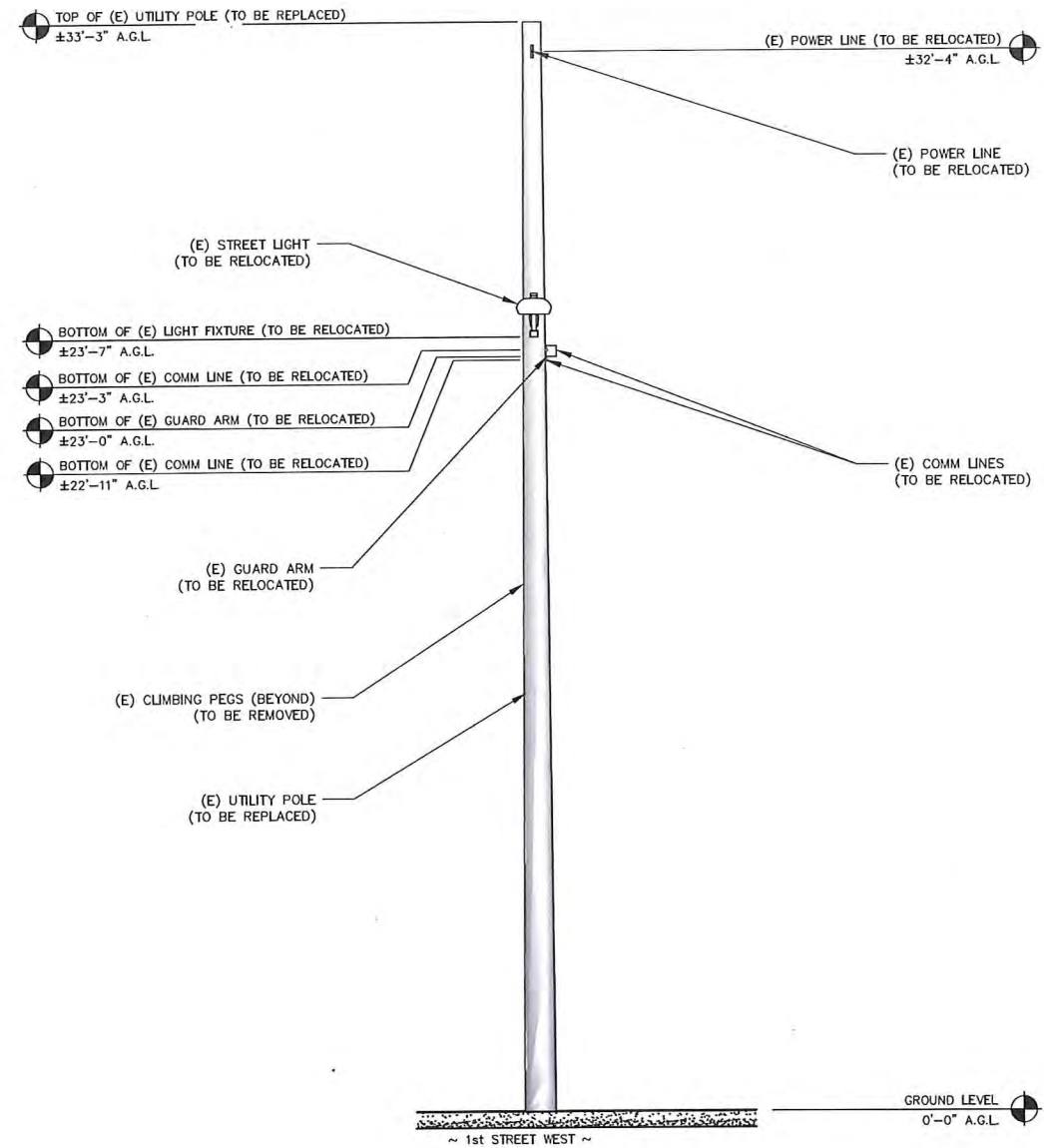

1 EXISTING WEST ELEVATION

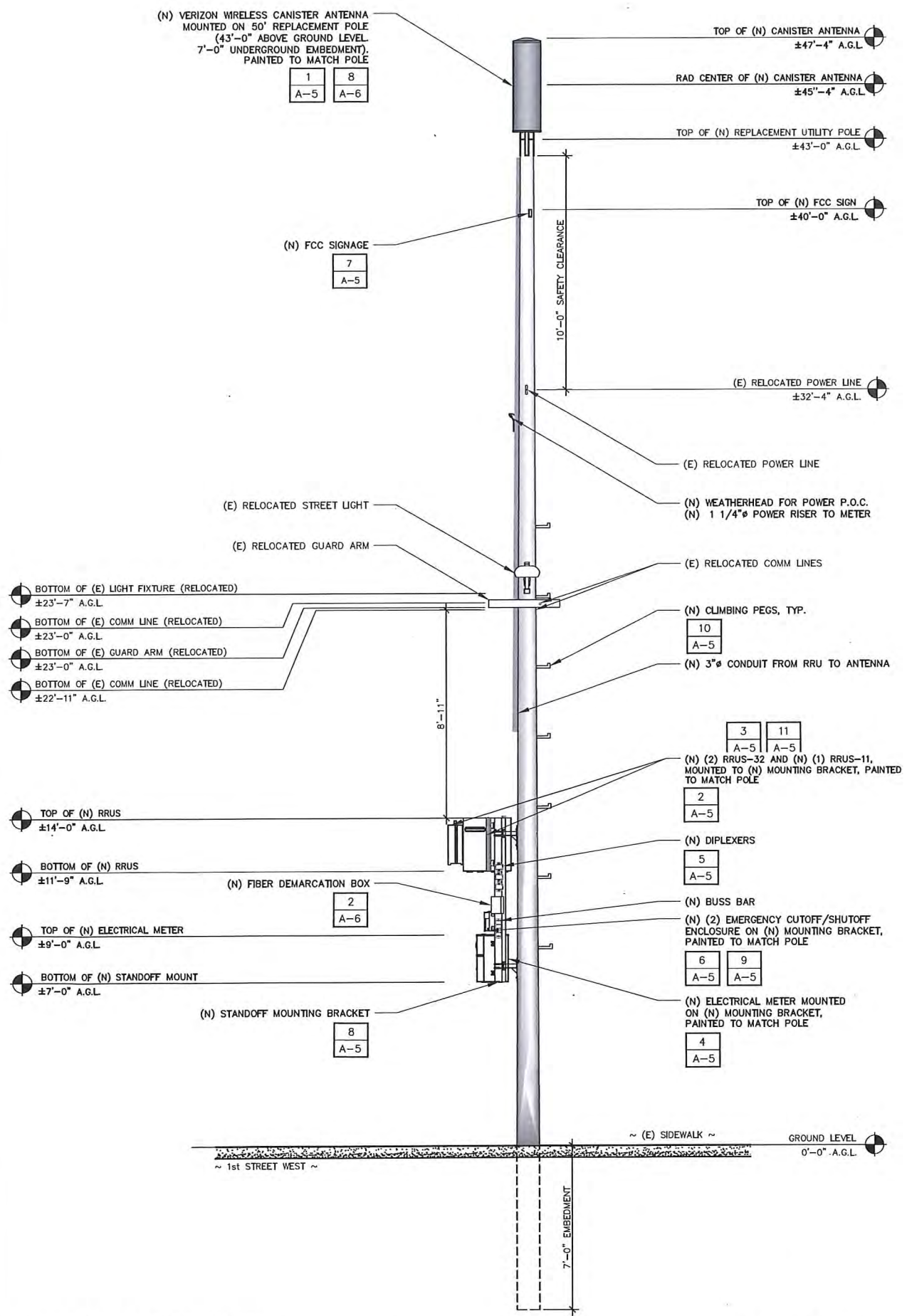
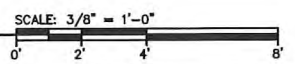

2 PROPOSED WEST ELEVATION

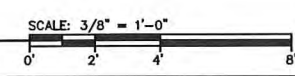

Prepared For:
verizon
 2785 MITCHELL DRIVE, SUITE 9
 WALNUT CREEK, CA 94598

Prepared For:

Site Number:
 425102
 Site Name:
 SONOMA 012
 Site Address:
 574 1st STREET WEST
 SONOMA CA 95476
 County:
 SONOMA COUNTY

Engineer:

 841 ARNOLD DRIVE, SUITE A
 MARTINEZ, CA 94553
 www.TheCBRGroup.com

Licenser:

IT IS A VIOLATION OF LAW FOR ANY PERSON, UNLESS THEY ARE ACTING UNDER THE DIRECTION OF A LICENSED PROFESSIONAL ENGINEER, TO ALTER THIS DOCUMENT.

Issued For:
 CONSTRUCTION

REV	DATE	DESCRIPTION	BY
D	06/12/18	REMOVE BBU	WM
C	03/13/18	PLANNING COMMENTS	JG
B	08/28/17	100% CD'S FOR REVIEW	GC
A	08/02/17	90% CD'S FOR REVIEW	WM

Sheet Title:
 EXISTING AND PROPOSED
 WEST ELEVATIONS

Sheet Number:
A-4

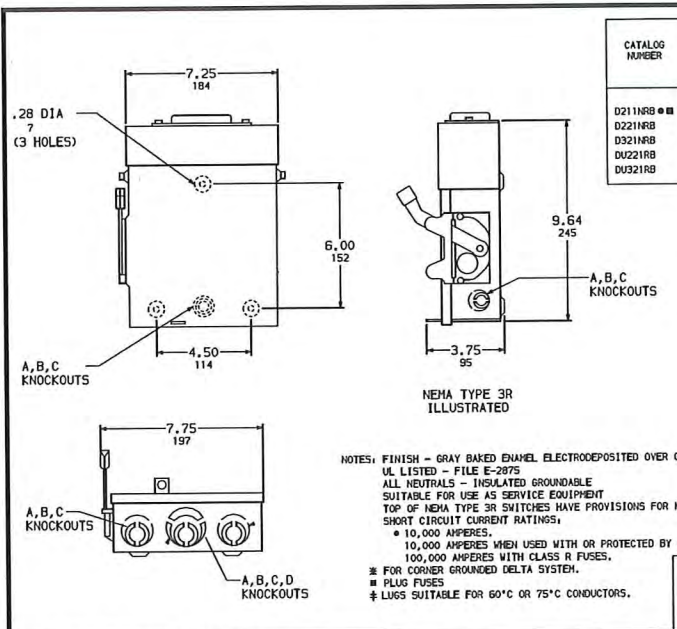

CATALOG NUMBER	VOLTAGE RATINGS	WIRING DIAG.	HORSEPOWER RATINGS					
			120VAC			240VAC		
			STD.	HAX.	STD.	HAX.	STD.	HAX.
D211HRB	240VAC	A	1/2	2	1 1/2	-	3	-
D221HRB	240VAC	A	-	-	1 1/2	3	3	7 1/2
D321HRB	240VAC	B	-	-	1 1/2	3	3	7 1/2
D421HRB	240VAC	C	-	-	-	-	3	-
D521HRB	240VAC	D	-	-	-	-	3	7 1/2

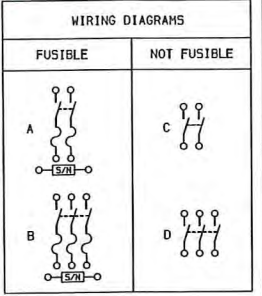

DUAL DIMENSIONS, INCHES / MILLIMETERS

TERMINAL LUGS*			
AMPERES	MAX. WIRE	MIN. WIRE	TYPE
30	# 6 AWG	# 12 AWG	AL
	# 6 AWG	# 14 AWG	CU

KNOCKOUTS				
SYMBOL	A	B	C	D
CONDUIT SIZE	.50	.75	1	1.25

NOTES: FINISH - GRAY BAKED ENAMEL ELECTRODEPOSITED OVER CLEANED PHOSPHATIZED STEEL.
UL LISTED - FILE E-2875
ALL NEUTRALS - INSULATED GROUNDABLE
SUITABLE FOR USE AS SERVICE EQUIPMENT
TOP OF NEHA TYPE 3R SWITCHES HAVE PROVISIONS FOR MAXIMUM 1 1/2" BOLT-ON HUB.
SHORT CIRCUIT CURRENT RATINGS:
* 10,000 AMPERES.
* 10,000 AMPERES WHEN USED WITH OR PROTECTED BY CLASS H OR K FUSES.
* 100,000 AMPERES WITH CLASS R FUSES.
* FOR CORNER GROUND DELTA SYSTEM.
* PLUG FUSES
* LUGS SUITABLE FOR 60°C OR 75°C CONDUCTORS.

GENERAL DUTY SAFETY SWITCHES
VISIBLE BLADE TYPE
30 AMPERE
ENCLOSURE - NEHA TYPE 3R RAINPROOF

SQUARE D COMPANY
ENG. NO. 1852

Normal Shut-Down Protocols:
1. Call 800-264-6620 24HRS prior to schedule a shut-down day and time.
2. Give NOC the Node number _____
3. On scheduled day of shut-down, Pull the disconnect handle to "OFF" position.
4. Call NOC when work is completed.

Emergency Shut-Down Protocols:
1. Call (800) 264-6620 NOC.
2. Give NOC the Node number _____
3. Pull the disconnect handle to the "OFF" position.
4. Call NOC when work is completed.

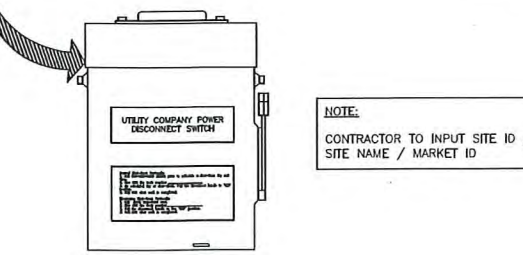

MANUFACTURER: ERICSSON
MODEL: RRUS-11
DEPTH: 182 mm / 7.2 in.
LENGTH: 500 mm / 19.7 in.
WIDTH: 431 mm / 17.0 in.
WEIGHT: 23 kg / 60.0 lb.
FREQUENCY: REFER TO RF DATA SHEET

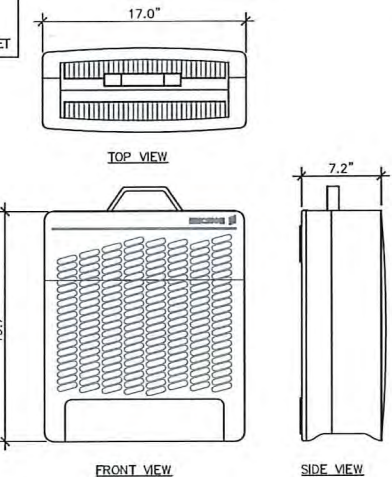

Prepared For:
verizon
2785 MITCHELL DRIVE, SUITE 9
WALNUT CREEK, CA 94598

Prepared For:

Site Number:
425102

Site Name:
SONOMA 012

Site Address:
574 1st STREET WEST
SONOMA CA 95476

County:
SONOMA COUNTY

Engineer:
THE CBR GROUP
841 ARNOLD DRIVE, SUITE A
MARTINEZ, CA 94553
www.TheCBRGroup.com

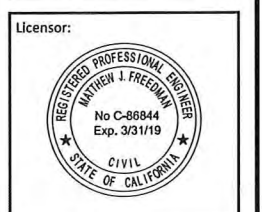

IT IS A VIOLATION OF LAW FOR ANY PERSON, UNLESS THEY ARE ACTING UNDER THE DIRECTION OF A LICENSED PROFESSIONAL ENGINEER, TO ALTER THIS DOCUMENT.

Issued For:
CONSTRUCTION

REV	DATE	DESCRIPTION	BY
D	06/12/18	REMOVE BBU	WM
C	03/13/18	PLANNING COMMENTS	JG
B	08/28/17	100% CD'S FOR REVIEW	GC
A	08/02/17	90% CD'S FOR REVIEW	WM

Sheet Title:
EQUIPMENT AND CONSTRUCTION DETAILS

Sheet Number:
A-5

SHUTDOWN DISCONNECT SWITCH

SCALE: N.T.S. 9

SHUTDOWN DISCONNECT BOX

SCALE: N.T.S. 6

RRUS-11 DETAIL

SCALE: N.T.S. 3

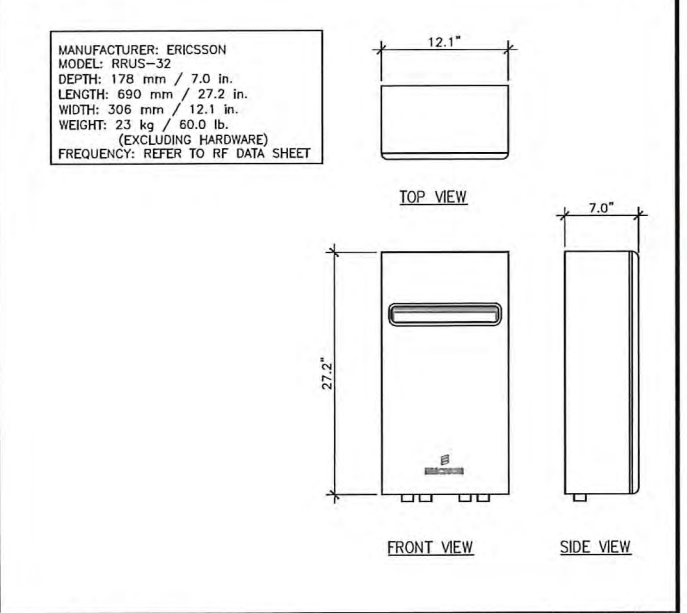
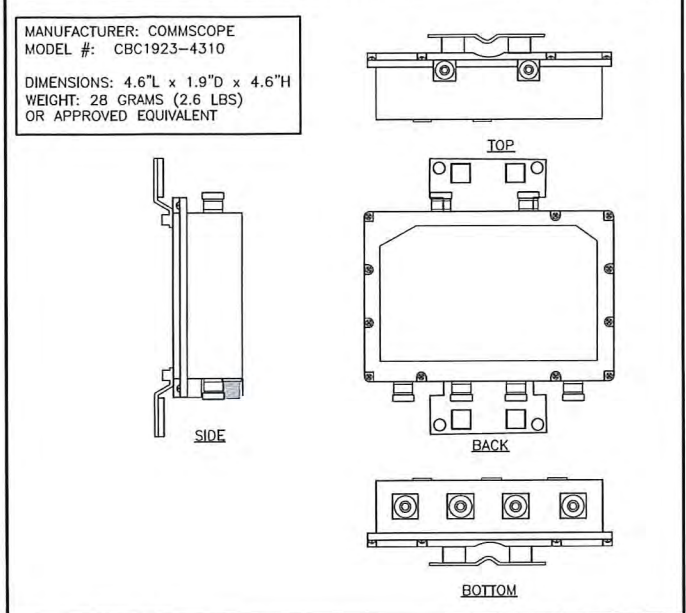
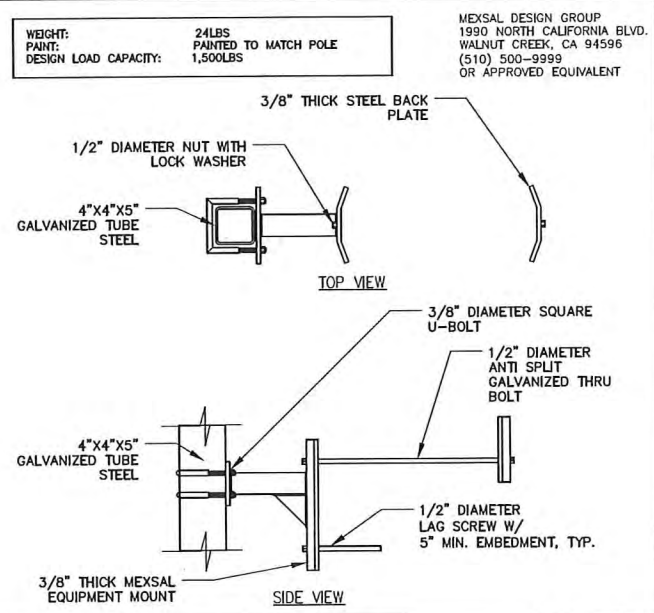

RRU SUPPORT

SCALE: N.T.S. 11

EQUIPMENT MOUNT DETAIL

SCALE: N.T.S. 8

DIPLEXER DETAIL

SCALE: N.T.S. 5

RRUS-32 DETAIL

SCALE: N.T.S. 2

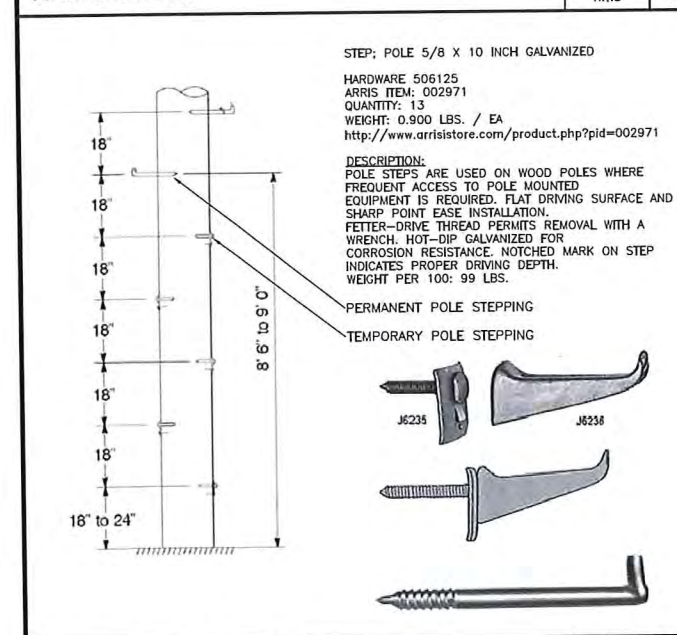

CAUTION

Transmitting Antenna(s)

Radio frequency fields beyond this point MAY EXCEED the FCC Occupational exposure limit. Obey all posted signs and site guidelines.
Call Verizon Wireless at 1-800-264-6620 prior working beyond this point.

STATE: _____ SWITCH: _____
SITE ID: _____
SECTOR/NODE: _____

RSI 6404.5D

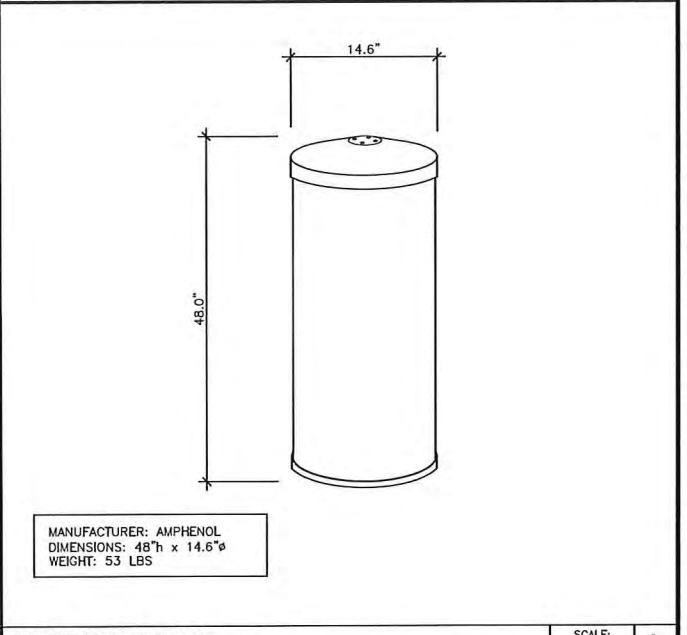
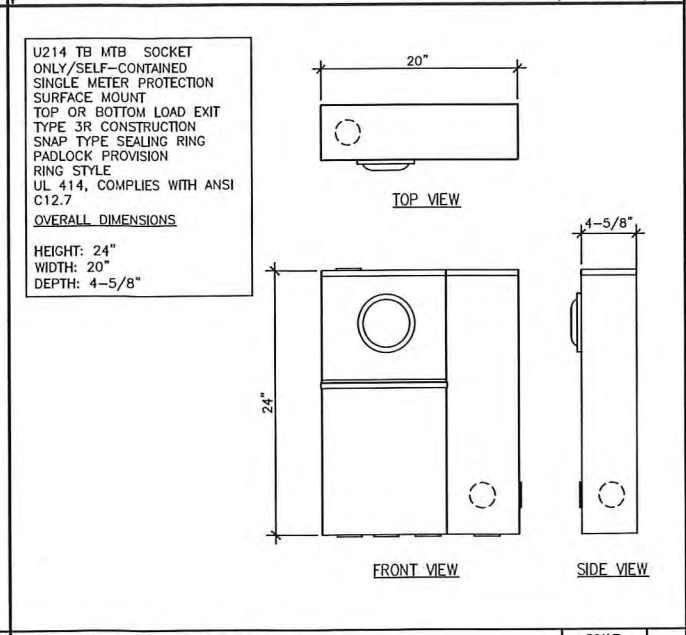

POLE STEPPING DETAILS

SCALE: N.T.S. 10

CAUTION SIGN

SCALE: N.T.S. 7

U214TB METER DETAILS

SCALE: N.T.S. 4

ANTENNA DETAIL

SCALE: N.T.S. 1

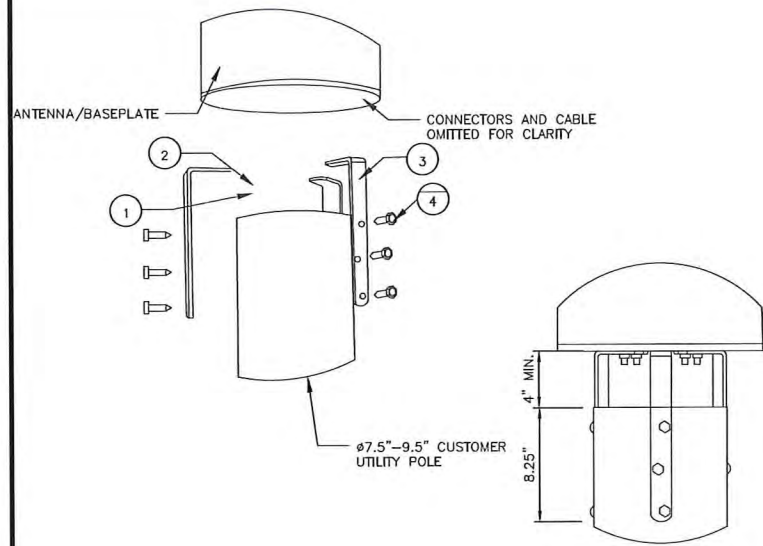

WB3X-MKS-01
UTILITY POLE MOUNTING KIT FOR CYLINDRICAL ANTENNAS

- STEP 1 ATTACH POLE MOUNT BRACKETS (ITEMS 3) TO ANTENNA/BASE PLATE USING FASTENERS (ITEMS 1 AND 2). TIGHTEN TO 15 N(11 FT-LBS)
- STEP 2 ATTACH POLE MOUNT BRACKETS (ITEM 3) ANTENNA ASSEMBLY TO CUSTOMER UTILITY POLE USING LAG SCREWS (ITEMS 4)
- STEP 3 MAKE ALL ELECTRICAL CONNECTIONS WEATHERPROOF WITH SELF-AMALGAMATING TAPE

PARTS LIST	DESCRIPTION	QUANTITY
ITEM - 1	NUT HEX, 3/8- 16 HDG	6
ITEM - 2	LOCK WASHER 3/8 HDG	6
ITEM - 3	POLE MOUNT BRACKET	3
ITEM - 4	GALVANIZED HEX LAG SCREW (1/2x2" LONG	9
MECHANICAL CHARACTERISTICS		
WEIGHT	2.7 KG (6LBS)	

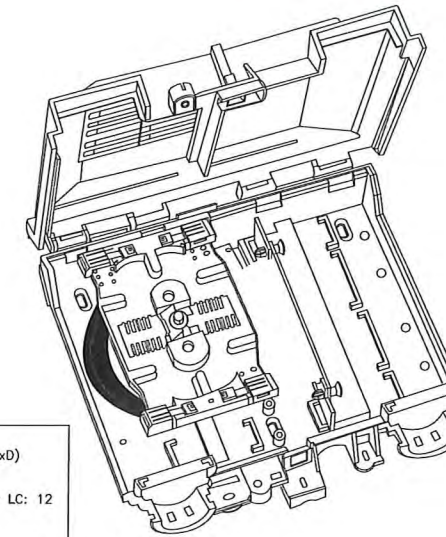

Dimensions:
8.54"x10"x2.88" (HxWxD)

Capacity:
6-Pack duplex SC or LC; 12 fibers

Special Features:
Available as single or dual door enclosure

Prepared For:
verizon
2785 MITCHELL DRIVE, SUITE 9
WALNUT CREEK, CA 94598

Prepared For:

Site Number:
425102

Site Name:
SONOMA 012

Site Address:
574 1st STREET WEST
SONOMA CA 95476

County:
SONOMA COUNTY

Engineer:
THE CBR GROUP
841 ARNOLD DRIVE, SUITE A
MARTINEZ, CA 94553
www.TheCBRGroup.com



IT IS A VIOLATION OF LAW FOR ANY PERSON, UNLESS THEY ARE ACTING UNDER THE DIRECTION OF A LICENSED PROFESSIONAL ENGINEER, TO ALTER THIS DOCUMENT.

Issued For:
CONSTRUCTION

REV	DATE	DESCRIPTION	BY
D	06/12/18	REMOVE BBU	WM
C	03/13/18	PLANNING COMMENTS	JG
B	08/28/17	100% CD'S FOR REVIEW	GC
A	08/02/17	90% CD'S FOR REVIEW	WM

Sheet Title:
EQUIPMENT AND
CONSTRUCTION
DETAILS

Sheet Number:
A-6

WB3X-MKS-01 ANTENNA MOUNT DETAIL

SCALE: 8 NOT USED

SCALE: 3 FIBER DEMARCATION BOX DETAIL

SCALE: 2

NOT USED

SCALE: 7 NOT USED

SCALE: 5

NOT USED

SCALE: 6 NOT USED

SCALE: 4 NOT USED

SCALE: 1

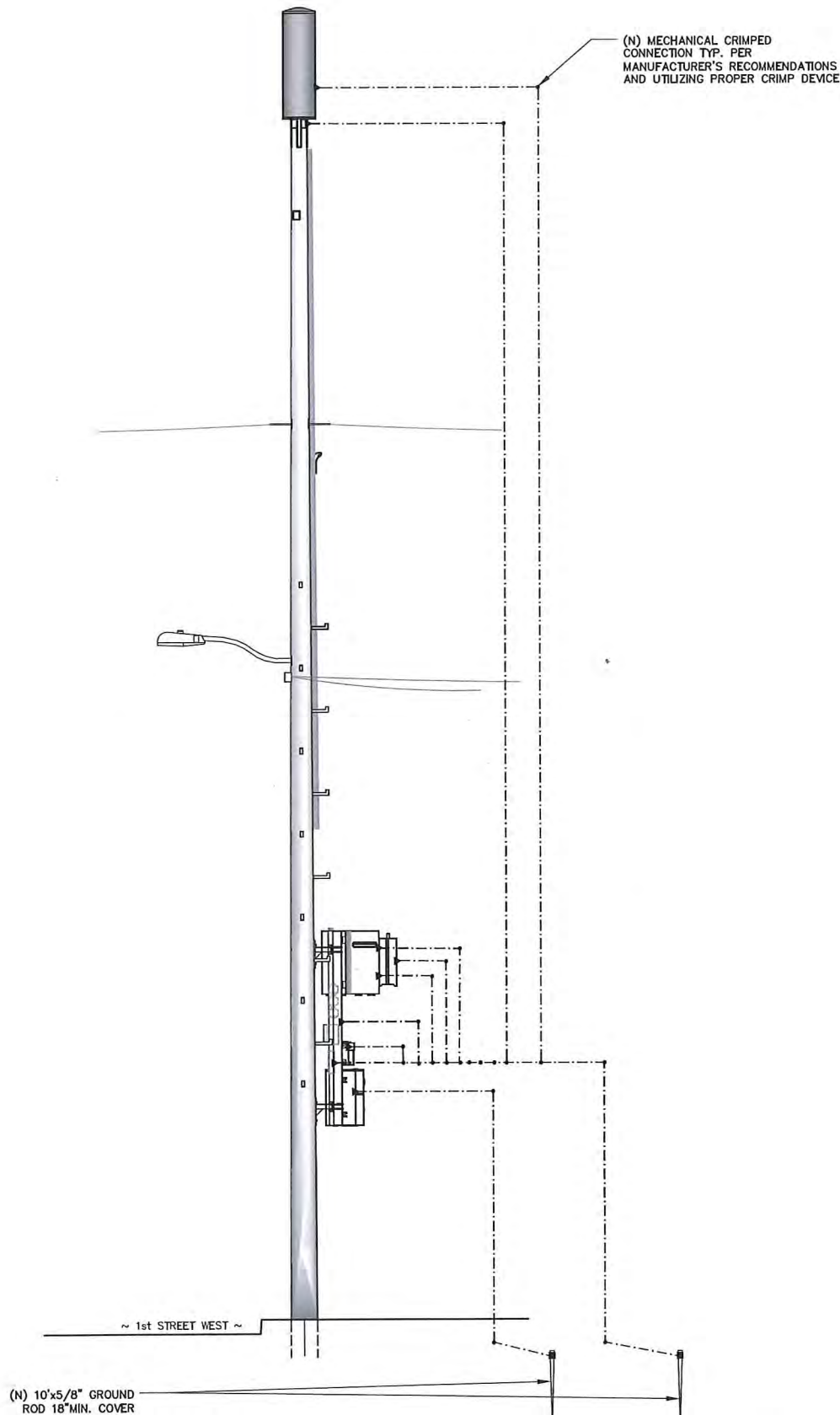

1 POLE GROUNDING DIAGRAM

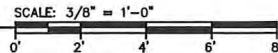

POWER AND TELCO CONNECTIONS:

1. POWER AND TELCO POINT OF CONNECTION AND ROUTE ARE PRELIMINARY AND SUBJECT TO CHANGE TO CONFIRMATION BY THE UTILITY COMPANIES RESPECTIVELY. CONTRACTOR SHALL COORDINATE WITH UTILITY COMPANY FOR FINAL AND EXACT WORK/MATERIALS REQUIREMENTS AND CONSTRUCT TO UTILITY ENGINEERING PLAN AND SPECIFICATIONS ONLY WHERE APPLICABLE PRE PROJECT SCOPE OF WORK.
2. CONTRACTOR SHALL FURNISH AND INSTALL CONDUIT, PULL WIRES, CABLE PULL BOXES, CONCRETE ENCASEMENT OF CONDUIT, TRANSFORMER PAD, BARRIERS, RISER TRENCHING, BACK FILL AND UTILITY FEES, AND INCLUDE REQUIREMENTS IN THE SCOPE.
3. CONTRACTOR SHALL LABEL ALL MAIN DISCONNECT SWITCHES AS REQUIRED BY CODE.

POWER AND TELCO CONNECTIONS:

1. SUBCONTRACTOR SHALL PROVIDE METER WITH DIST. PANEL AND BREAKERS FOR POWER TO THE BTS UNITS AND THE BTS/UTILITY CABINET.
2. ALL SERVICE EQUIPMENT AND INSTALLATIONS SHALL COMPLY WITH THE N.E.C. AND UTILITY COMPANY AND LOCAL CODE REQUIREMENTS.
3. SUBCONTRACTOR SHALL PROVIDE ELECTRICAL SERVICE ENTRANCE EQUIPMENT WITH FAULT CURRENT RATINGS GREATER THAN THE AVAILABLE FAULT CURRENT FROM THE POWER UTILITY.
4. FIELD ROUTE CONDUIT TO CABINETS AS REQUIRED.
5. MAXIMUM ONE WAY CIRCUIT RUN NOT TO EXCEED 75 FEET.

GENERAL ELECTRICAL NOTES:

1. PROVIDE ALL ELECTRICAL WORK & MATERIALS AS SHOWN ON THE DWGS, AS CALLED FOR HEREIN, & AS IS NECESSARY TO FURNISH A COMPLETE INSTALLATION.
2. THE INSTALLATION SHALL CONFORM TO THE REQUIREMENTS OF THE CURRENT ADOPTED CALIFORNIA ELECTRICAL CODE, STATE OF CALIFORNIA TITLE24, ALL OTHER APPLICABLE CODES AND ORDINANCES & THE REQUIREMENTS OF THE FIRE MARSHALL. ALL EQUIPMENT & WIRING SHALL BEAR THE APPROVAL STAMP OF UNDERWRITERS LABORATORY (UL) OR AN APPROVED TESTING LABORATORY, PAYMENT FOR ALL INSPECTION FEES AND PERMITS ARE PART OF THIS CONTRACT.
3. THE CONTRACTOR SHALL BE RESPONSIBLE FOR THE SAFETY AND GOOD CONDITION OF ALL MATERIALS & EQUIPMENT FOR THE ENTIRE INSTALLATION & UNIT COMPLETION OF WORK, ERECT & MAINTAIN APPROVED & SUITABLE BARRIERS, PROTECTIVE DEVICES & WARNING SIGNS, BE FULLY RESPONSIBLE FOR ANY LOSS OR INJURY TO PERSONS OR PROPERTY RESULTING FROM NEGLIGENCE AND/OR ENFORCEMENT OF ALL SAFETY PRECAUTIONS & WARNINGS.
4. COORDINATE THE ELECTRICAL INSTALLATION WITH ALL OTHER TRADES.
5. ALL SAW CUTTING, TRENCHING, BACK FILLING & PATCHING SHALL BE PART OF THIS CONTRACT.
6. FINALIZE ALL ELECTRICAL SERVICE ARRANGEMENTS, INCLUDING VERIFICATION OF LOCATIONS, DETAILS, COORDINATION OF THE INSTALLATION & PAYMENT OF ACCRUED CHARGES WITH LOCAL POWER COMPANY, VERIFY LOCATION FOR FACILITIES & DETAILS WITH POWER UTILITY, IN ADDITION TO THE REQUIREMENTS SHOWN IN THE CONTRACT DOCUMENTS, WORK SHALL COMPLY WITH CONSTRUCTION STANDARDS & SERVICE REQUIREMENTS OF THE RESPECTIVE UTILITIES, INCLUDING ANY SUPPLEMENTAL DWGS ISSUED & SHALL BE SUBJECT TO APPROVAL OF THESE UTILITIES.
7. ALL WIRING SHALL BE COPPER. INSULATION FOR BRANCH CIRCUIT CONDUCTORS SHALL BE TYPE "THWN" CONDUCTORS LARGER AND #6 AWG MAY BE TYPE "THWN" OR "TWN".
8. PROVIDE CONDUIT SEALS FOR ALL CONDUITS PENETRATING WEATHERPROOFING OR WEATHERPROOF ENCLOSURE ENVELOPE. MASTIC SEAL ALL CONDUIT OPENING PENETRATIONS COMPLETELY WATERTIGHT.
9. UNLESS SHOWN OTHERWISE, FUSED DISCONNECT SWITCHES SHALL BE PROVIDED WITH LOW-PEAK, S/DUAL ELEMENT FUSES SIZED TO EQUIPMENT NAMEPLATE FUSE CURRENT RATING. MOTOR STARTERS SHALL BE PROVIDED WITH SIMILARLY SIZED FUSIBLE ELEMENTS, SWITCHES AND OTHER OUTDOOR EQUIPMENT SHALL BE RATED NEMA 3R AND/OR UL LISTED FOR WET ENVIRONMENT.
10. THE CONTRACTOR SHALL BE RESPONSIBLE FOR TESTING THE GROUNDING SYSTEM AND ENSURING A 5 OHM OR LESS GROUNDING PATH, ADDITIONAL GROUND RODS AND/OR CHEMICAL ROD SYSTEM SHALL BE USED TO ACHIEVE THIS REQUIREMENT IF THE GIVEN DESIGN CANNOT BE

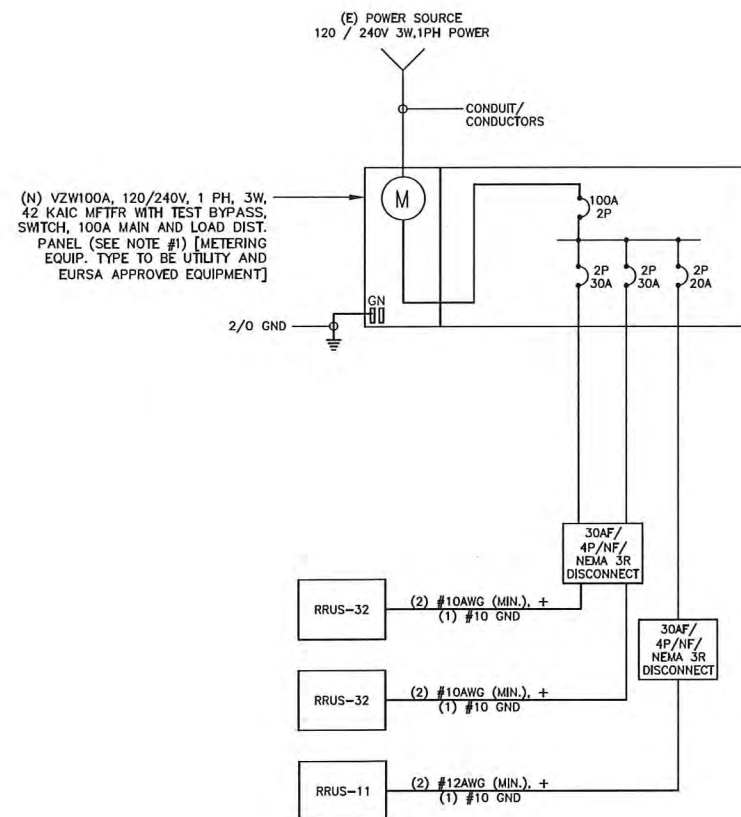

LOAD CALCULATIONS--VERIZON WIRELESS

EXISTING LOAD: 0 AMPS
 NEW LOAD: 10.0 AMPS MAX
 NEW TOTAL LOAD: 10.0 AMPS MAX

POWER AND TELCO DESIGN IS BASED ON INITIAL SITE VISIT.

CONTRACTOR SHALL OBTAIN CURRENT UTILITY COORDINATOR PLANS PRIOR TO START OF CONSTRUCTION.

AVAILABLE FAULT CURRENT PER UTILITY.

NOTE: CONTRACTOR TO CHECK WITH UTILITY TO ENSURE ELEC. METER IS BRACED FOR ACTUAL FAULT CURRENT.

Prepared For:



Prepared For:

Site Number:

425102

Site Name:

SONOMA 012

Site Address:

574 1st STREET WEST
 SONOMA CA 95476

County:

SONOMA COUNTY

Engineer:



841 ARNOLD DRIVE, SUITE A
 MARTINEZ, CA 94553
 www.TheCBRGroup.com

Licenser:



IT IS A VIOLATION OF LAW FOR ANY PERSON, UNLESS THEY ARE ACTING UNDER THE DIRECTION OF A LICENSED PROFESSIONAL ENGINEER, TO ALTER THIS DOCUMENT.

Issued For:

CONSTRUCTION

REV	DATE	DESCRIPTION	BY
D	06/12/18	REMOVE BBU	WM
C	03/13/18	PLANNING COMMENTS	JG
B	08/28/17	100% CD'S FOR REVIEW	GC
A	08/02/17	90% CD'S FOR REVIEW	WM

Sheet Title:

ELECTRICAL GROUND DIAGRAMS, SINGLE LINE DIAGRAM

Sheet Number:

E-1

2 SINGLE LINE DIAGRAM

N.T.S.

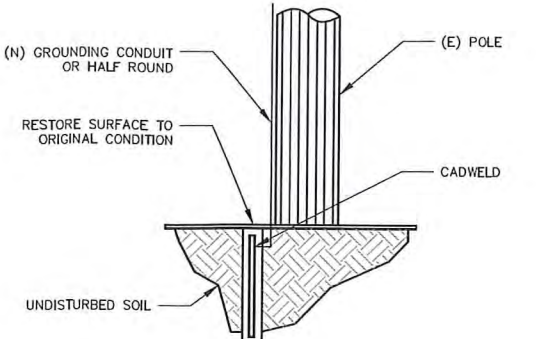

NOTES:
 1. IF GROUND ROD IS INSTALLED IN SIDEWALK AREA, CORE DRILL SIDEWALK PRIOR TO INSTALLING INSPECTION WELL.
 2. EXPOSED CONCRETE TO HAVE BROOM FINISH.

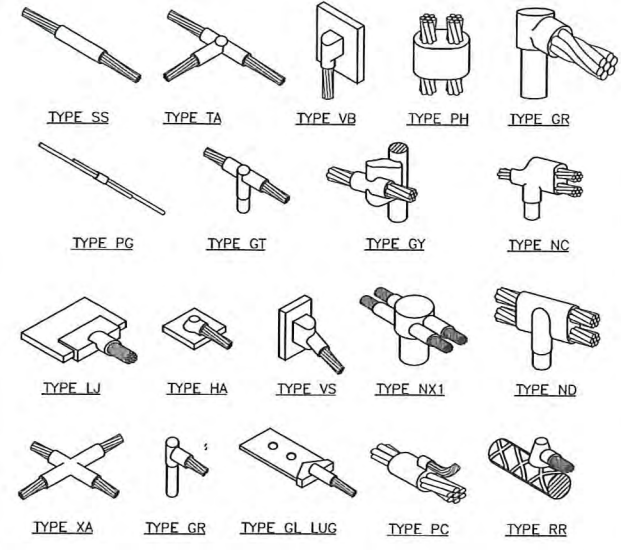
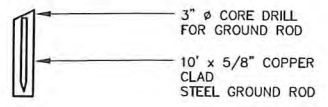

NOT USED SCALE: N.T.S. 10

NOT USED SCALE: N.T.S. 7

POLE GROUNDING ROD SCALE: N.T.S. 4

EXOTHERMIC WELD CONNECTION SCALE: N.T.S. 3

NOTES:
 • ETCHED POLYPROPYLENE FACE
 • FACE ANCHORED IN CONCRETE
 • ULTRA-VIOLET INHIBITOR
 • EXCEEDS ASTM-D1693 STANDARDS
 • FOR ENVIRONMENTAL STRESS CRACKING RESISTANCE

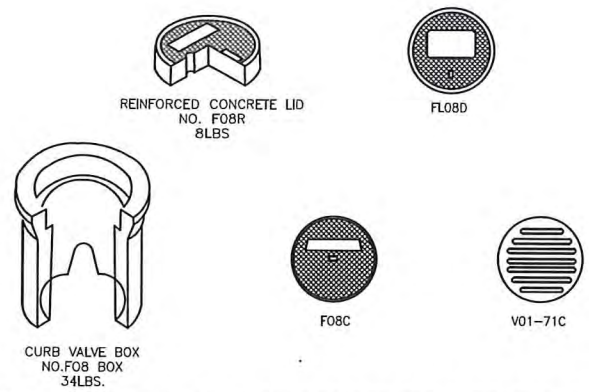

FOBBOX	BOX	34LBS	F08 CURB VALVE BOX (8" I.D. X 12" HIGH) - 48 PER PALLET
FORBR	LID	8LBS	REINFORCED CONCRETE LID WITH PLASTIC RING
FORBC	LID	8LBS	CAST IRON LID
FLOBD	LID	2LBS	FIBRELYTE LID, NON-CONCRETE
V01-71C	LID	12LBS	COST IRON GRATE ADA COMPLIANT

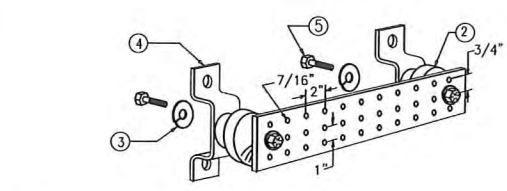

NOTES:
 1. GALVANIZED STEEL GROUND BAR, "X 1/4" X 20", NEWTON INSTRUMENT CO. CAT. NO. B-6142 OR EQUAL. HOLE CENTERS TO MATCH NEMA DOUBLE LUG CONFIGURATION. (ACTUAL GROUND BAR SIZE WILL VARY BASED ON NUMBER OF GROUND CONNECTIONS)
 2. INSULATORS, NEWTON INSTRUMENT CAT. NO. 3061-4 OR EQUAL
 3. 5/8" LOCKWASHER, NEWTON INSTRUMENT CO. CAT. NO. 3015-8 OR EQUAL
 4. WALL MOUNTING BRACKET, NEWTON INSTRUMENT CO. CAT NO. A-6056 OR EQUAL
 5. 5/8-11 X 1" HHCS BOLTS, NEWTON INSTRUMENT CO. CAT NO. 3012-1 OR EQUAL
 6. INSULATORS SHALL BE ELIMINATED WHEN BONDING DIRECTLY TO TOWER/MONOPOLE STRUCTURE. CONNECTION TO TOWER/MONOPOLE STRUCTURE SHALL BE PER MANUFACTURERS RECOMMENDATIONS.

NOTE: ALL HARDWARE SHALL BE STAINLESS STEEL

NOT USED SCALE: N.T.S. 11

NOT USED SCALE: N.T.S. 8

F08 BOX GROUND WELL DETAIL SCALE: N.T.S. 5

BUSS BAR SCALE: N.T.S. 2

NOTES:
 1. DO NOT INSTALL CABLE GROUND KIT AT A BEND AND ALWAYS DIRECT GROUND WIRE DOWN TO GROUND BAR.
 2. GROUNDING KIT SHALL BE TYPE AND PART NUMBER AS SUPPLIED OR RECOMMENDED BY CABLE MANUFACTURER.
 3. WEATHER PROOFING SHALL BE (TYPE AND PART NUMBER AS SUPPLIED OR RECOMMENDED BY CABLE MANUFACTURER.)

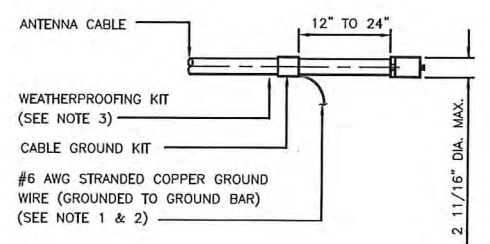

NOT USED SCALE: N.T.S. 12

NOT USED SCALE: N.T.S. 9

NOT USED SCALE: N.T.S. 6

CONNECTION OF CABLE GND. KIT TO ANTENNA SCALE: N.T.S. 1

Prepared For:
verizon
 2785 MITCHELL DRIVE, SUITE 9
 WALNUT CREEK, CA 94598

Prepared For:

Site Number:
425102
 Site Name:
SONOMA 012

Site Address:
574 1st STREET WEST
SONOMA CA 95476

County:
SONOMA COUNTY

Engineer:

 841 ARNOLD DRIVE, SUITE A
 MARTINEZ, CA 94553
 www.TheCBRGroup.com

Licenser:

IT IS A VIOLATION OF LAW FOR ANY PERSON, UNLESS THEY ARE ACTING UNDER THE DIRECTION OF A LICENSED PROFESSIONAL ENGINEER, TO ALTER THIS DOCUMENT.

Issued For:
CONSTRUCTION

REV	DATE	DESCRIPTION	BY
D	06/12/18	REMOVE BBU	WM
C	03/13/18	PLANNING COMMENTS	JG
B	08/28/17	100% CD'S FOR REVIEW	GC
A	08/02/17	90% CD'S FOR REVIEW	WM

Sheet Title:
ELECTRICAL DETAILS

Sheet Number:
E-2

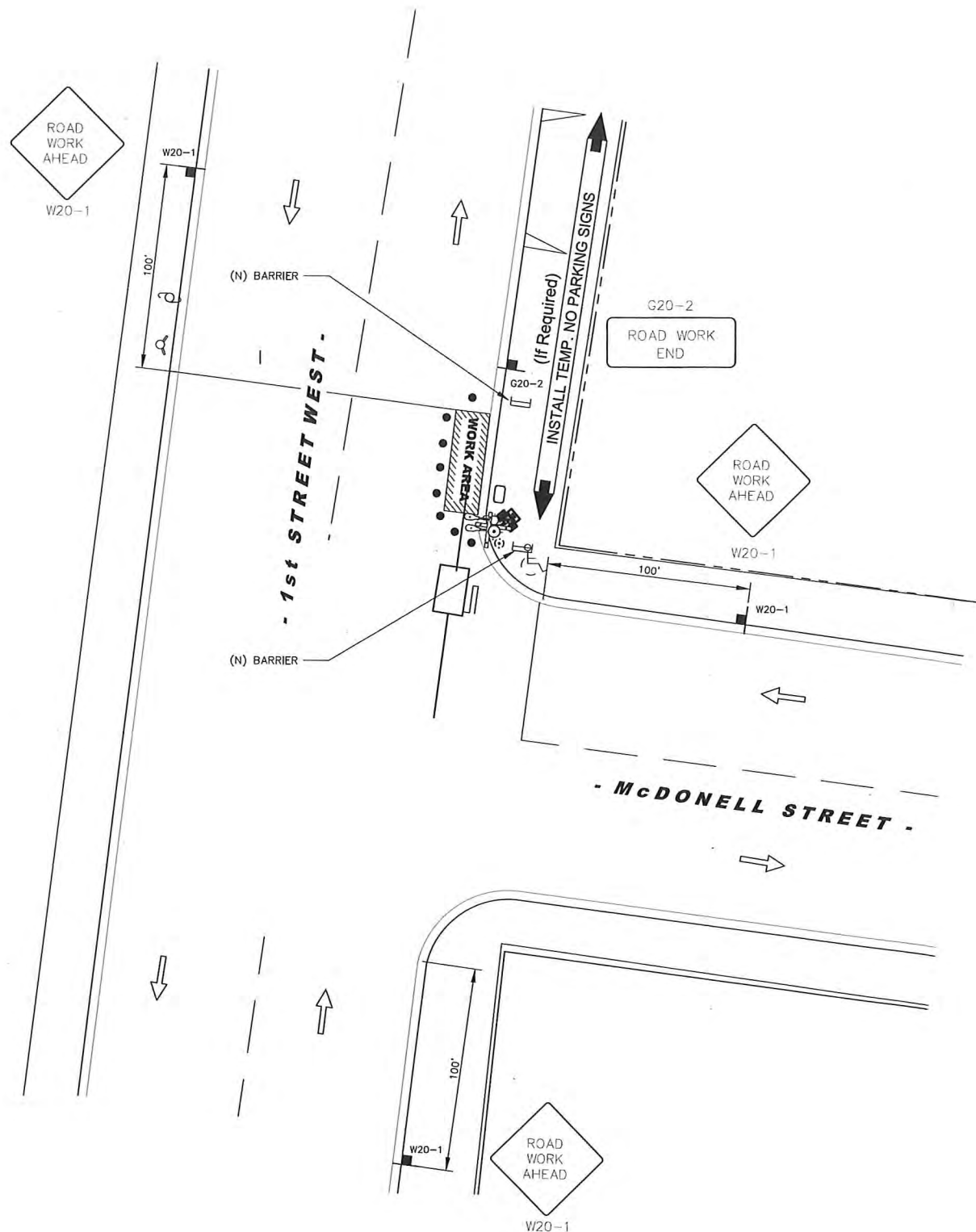
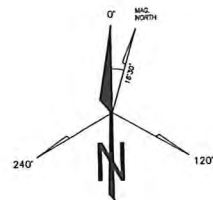

GENERAL TRAFFIC CONTROL NOTES	
TRAFFIC SHALL CONFORM TO THE 2014 CALIFORNIA MANUAL ON UNIFORM TRAFFIC CONTROL DEVICES (MUTCD) AND THE 2012 WATCH HANDBOOK.	
ACCESS TO DRIVEWAYS SHALL BE MAINTAINED AT ALL TIMES.	
ONE LANE OF TRAFFIC IN EACH DIRECTION AND ALL HIGH VOLUME TURNING LANES SHALL BE MAINTAINED AT ALL TIMES ON ALL STREETS AT A MINIMUM LANE WIDTH OF 10 FEET.	
ANY CONFLICTING SIGNS, STRIPING AND PAVEMENT MARKINGS SHALL BE REMOVED OR COVERED BEFORE TRAFFIC CONTROL IS IN PLACE. ANY SIGN, STRIPING OR PAVEMENT MARKING REMOVED OR COVERED SHALL BE REPLACED WHEN TRAFFIC CONTROL IS NO LONGER NECESSARY.	
SAFE PEDESTRIAN ACCESS SHALL BE MAINTAINED AT ALL TIMES.	

NOTES:

- FACILITY IS UNMANNED AND NOT FOR HUMAN HABITATION, ACCESSIBILITY ACCESS AND REQUIREMENTS ARE NOT REQUIRED, IN ACCORDANCE WITH CALIFORNIA STATE ADMINISTRATIVE CODE, PART 2, TITLE 24, SECTION 1103B.1, EXCEPTION 1 & SECTION 1134B.2.1, EXCEPTION 4.
- STREET SIDE PARKING AVAILABLE ON THE BOTH SIDES OF THE STREET.

TABLE 6H-3 & 6H-4 - FROM THE 2014 CALIFORNIA MUTCD				
POSTED SPEED LIMIT - MPH	MERGING TAPER LENGTH 'L' - FEET	SHIFTING TAPER LENGTH 'L/2' - FEET	SHOULDER TAPER LENGTH 'L/2' - FEET	SIGN SPACING ADVANCE OF TAPER & BETWEEN SIGNS - FEET
20	80	40	27	100
25	125	63	42	100
30	180	90	60	250
35	245	123	82	250
40	320	160	107	250
45	540	270	180	350
50	600	300	200	350
55	660	330	220	350

MAINTAIN DRIVEWAY ACCESS AT ALL TIME

LEGEND

- TYPE III BARRICADE W/ SIGN
- TYPE II BARRICADE W/ SIGN
- CHANNELIZING DEVICE
- TRAFFIC CONE WITH CLIP ON SIGN
- SIGN
- SIGNALIZED INTERSECTION
- ARROW PANEL (FLASHING ARROW) (WHERE REQUIRED)
- HIGH LEVEL WARNING DEVICE (FLAGTREE) (OPTIONAL)
- FLAGGER
- TANS TOW AWAY NO STOPPING ___ TO ___ (SHOW HOURS)
- TANSAT TOW AWAY NO STOPPING ANY TIME
- WORK ZONE (ACTIVITY AREA) LIMITS
- DIRECTION OF TRAFFIC (NOT PAVEMENT MARKING)
- ROADWAY DESIGNATION (A THROUGH D)
- SITE

Prepared For:

verizon
2785 MITCHELL DRIVE, SUITE 9
WALNUT CREEK, CA 94598

Prepared For:

Site Number:
425102

Site Name:
SONOMA 012

Site Address:
574 1st STREET WEST
SONOMA CA 95476

County:
SONOMA COUNTY

Engineer:

THE CBR GROUP
841 ARNOLD DRIVE, SUITE A
MARTINEZ, CA 94553
www.TheCBRGroup.com

Licenser:



IT IS A VIOLATION OF LAW FOR ANY PERSON, UNLESS THEY ARE ACTING UNDER THE DIRECTION OF A LICENSED PROFESSIONAL ENGINEER, TO ALTER THIS DOCUMENT.

Issued For:
CONSTRUCTION

REV	DATE	DESCRIPTION	BY
D	06/12/18	REMOVE BBU	WM
C	03/13/18	PLANNING COMMENTS	JG
B	08/28/17	100% CD'S FOR REVIEW	GC
A	08/02/17	90% CD'S FOR REVIEW	WM

Sheet Title:
TRAFFIC CONTROL PLAN

Sheet Number:

TCP



VERIZON SMALL CELL FOR SONOMA POLYGON ALTERNATIVE SITE ANALYSIS

Verizon Small Cell Node "Sonoma 012" (near 574 1st St W.)

Prepared August 17, 2017



SHOT MAP OF PROPOSED SITE LOCATION AND ALTERNATIVES CONSIDERED



ALTERNATE SITE #1 (561 1ST ST W)



Node - Alternative Site #1

This alternative location is a wood utility pole located in the Public ROW. The nearest address is 561 1st St W.

Pole Elimination Justification:

This pole is not feasible for Verizon to locate on as it will not comply with G095 JPA Pole Standards as it will cause the climbing space to be blocked on the pole.

Additionally this pole location would not provide optimal spacing between the nodes in the polygon.

ALTERNATE SITE #2 (561-553 1ST ST W)

Node - Alternative Site #2

This alternative location is a wood utility pole located in the Public ROW. This pole is located on 561-553 1st St W.

Pole Elimination Justification:

This pole is not feasible for Verizon to locate on as it will not comply with G095 JPA Pole Standards as it will cause the climbing space to be blocked on the pole.

Additionally this pole location would not provide optimal spacing between the nodes in the polygon.



ALTERNATE SITE #3 (553 1ST ST W)



Node - Alternative Site #3

This alternative location is a wood utility pole located in the Public ROW. The nearest address is 553 1st St W.

Pole Elimination Justification:

This pole is not feasible for Verizon to locate on as it will not comply with G095 JPA Pole Standards as it will cause the climbing space to be blocked on the pole.

Additionally this pole location would not provide optimal spacing between the nodes in the polygon.

**ALTERNATE SITE #4
(589 Ist ST W)**



Node - Alternative Site #4

This alternative location is a wood utility pole located in the Public ROW. This pole is located on 589 Ist St W.

Pole Elimination Justification:

This pole is not feasible for Verizon to locate on as it will not comply with G095 JPA Pole Standards as it will cause the climbing space to be blocked on the pole.

Additionally this pole location would not provide optimal spacing between the nodes in the polygon.

THANK YOU

The CBR Group, Inc.

Christy Beltran

415.806.2323

Christy@thecbrgroup.com

Radio Frequency - Electromagnetic Energy (RF-EME) Jurisdictional Report

Site No. 425102
Sonoma 012
574 1st Street West
Sonoma, California 95476
Sonoma County
38° 17' 26.49" N, -122° 27' 32.88" W NAD83

EBI Project No. 6217003694
August 30, 2017



Prepared for:

Verizon Wireless
c/o The CBR Group Inc.
841 Arnold Drive Suite A & B
Martinez, CA 94553

Prepared by:



TABLE OF CONTENTS

EXECUTIVE SUMMARY	1
1.0 INTRODUCTION	2
2.0 SITE DESCRIPTION	2
3.0 FEDERAL COMMUNICATIONS COMMISSION (FCC) REQUIREMENTS	3
4.0 WORST-CASE PREDICTIVE MODELING	5
5.0 MITIGATION/SITE CONTROL OPTIONS	6
6.0 SUMMARY AND CONCLUSIONS	6
7.0 LIMITATIONS	6

APPENDICES

APPENDIX A	CERTIFICATIONS
APPENDIX B	RADIO FREQUENCY ELECTROMAGNETIC ENERGY SAFETY / SIGNAGE PLANS
APPENDIX C	ROOFVIEW® EXPORT FILES

EXECUTIVE SUMMARY

Purpose of Report

EnviroBusiness Inc. (dba EBI Consulting) has been contracted by Verizon Wireless to conduct radio frequency electromagnetic (RF-EME) modeling for Verizon Site 425102 located at 574 1st Street West in Sonoma, California to determine RF-EME exposure levels from proposed Verizon wireless communications equipment at this site. As described in greater detail in Section 2.0 of this report, the Federal Communications Commission (FCC) has developed Maximum Permissible Exposure (MPE) Limits for general public exposures and occupational exposures. This report summarizes the results of RF-EME modeling in relation to relevant FCC RF-EME compliance standards for limiting human exposure to RF-EME fields.

Statement of Compliance

A site is considered out of compliance with FCC regulations if there are areas that exceed the FCC exposure limits and there are no RF hazard mitigation measures in place. Any carrier which has an installation that contributes more than 5% of the applicable MPE must participate in mitigating these RF hazards.

As presented in the sections below, based on worst-case predictive modeling, there are no modeled areas on any accessible ground-level walking/working surface related to the proposed antennas that exceed the FCC's occupational or general public exposure limits at this site. Additionally, there are areas where workers who may be elevated above the ground may be exposed to power densities greater than the occupational limits. Therefore, workers should be informed about the presence and locations of antennas and their associated fields.

At the nearest walking/working surfaces to the Verizon antennas, the maximum power density generated by the Verizon antennas is approximately **6.50** percent of the FCC's general public limit (**1.30** percent of the FCC's occupational limit).

Recommended control measures are outlined in Section 5.0 and within a Site Safety Plan (attached); this plan includes instructions to shut down and lockout/tagout this wireless equipment in accordance with Verizon's standard operating protocol.

1.0 INTRODUCTION

Radio frequency waves are electromagnetic waves from the portion of the electromagnetic spectrum at frequencies lower than visible light and microwaves. The wavelengths of radio waves range from thousands of meters to around 30 centimeters. These wavelengths correspond to frequencies as low as 3 cycles per seconds (or hertz [Hz]) to as high as one gigahertz (one billion cycles per second).

Personal Communication (PCS) facilities used by Verizon in this area operate within a frequency range of 700-2100 MHz. Facilities typically consist of: 1) electronic transceivers (the radios or cabinets) connected to wired telephone lines; and 2) antennas that send the wireless signals created by the transceivers to be received by individual subscriber units (PCS telephones). Transceivers are typically connected to antennas by coaxial cables.

Because of the short wavelength of PCS services, the antennas require line-of-site paths for good propagation, and are typically installed a distance above ground level. Antennas are constructed to concentrate energy towards the horizon, with as little energy as possible scattered towards the ground or the sky. This design, combined with the low power of PCS facilities, generally results in no possibility for exposure to approach Maximum Permissible Exposure (MPE) levels, with the exception of in areas in the immediate vicinity of the antennas.

MPE limits do not represent levels where a health risk exists, since they are designed to provide a substantial margin of safety. These limits apply for continuous exposures and are intended to provide a prudent margin of safety for all persons, regardless of age, gender, size or health.

2.0 SITE DESCRIPTION

This project site includes one (1) tri-sector wireless telecommunication antenna on a utility pole located at 574 1st Street West in Sonoma, California.

Verizon Antenna Information (proposed Configuration)									
Antenna# and Model	Frequency (MHz)	# of Transmitters	Transmit Power (Watts)	Azimuth	Gain (dBd)	Feet above Ground (CL)	X	Y	Z
A1 Amphenol CUUT070X12Fxyz0	700	1	40	0°/120°/240°	9.85	45.33 ft AGL	50	50	43.33
	1900	1	40		14.35				
	2100	1	40		14.85				

The FCC guidelines incorporate two separate tiers of exposure limits that are based upon occupational/controlled exposure limits (for workers) and general population/uncontrolled exposure limits for members of the general public that may be exposed to antenna fields. While access to this site is considered uncontrolled, the analysis has considered exposures with respect to both controlled and uncontrolled limits as an untrained worker may access adjacent rooftop locations. Additional information regarding controlled/uncontrolled exposure limits is provided in Section 3.0. Appendix B presents a site safety plan that provides a plan view of the utility pole with antenna locations.

3.0 FEDERAL COMMUNICATIONS COMMISSION (FCC) REQUIREMENTS

The FCC has established Maximum Permissible Exposure (MPE) limits for human exposure to Radiofrequency Electromagnetic (RF-EME) energy fields, based on exposure limits recommended by the National Council on Radiation Protection and Measurements (NCRP) and, over a wide range of frequencies, the exposure limits developed by the Institute of Electrical and Electronics Engineers, Inc. (IEEE) and adopted by the American National Standards Institute (ANSI) to replace the 1982 ANSI guidelines. Limits for localized absorption are based on recommendations of both ANSI/IEEE and NCRP.

The FCC guidelines incorporate two separate tiers of exposure limits that are based upon occupational/controlled exposure limits (for workers) and general public/uncontrolled exposure limits for members of the general public.

Occupational/controlled exposure limits apply to situations in which persons are exposed as a consequence of their employment and in which those persons who are exposed have been made fully aware of the potential for exposure and can exercise control over their exposure. Occupational/controlled exposure limits also apply where exposure is of a transient nature as a result of incidental passage through a location where exposure levels may be above general public/uncontrolled limits (see below), as long as the exposed person has been made fully aware of the potential for exposure and can exercise control over his or her exposure by leaving the area or by some other appropriate means.

General public/uncontrolled exposure limits apply to situations in which the general public may be exposed or in which persons who are exposed as a consequence of their employment may not be made fully aware of the potential for exposure or cannot exercise control over their exposure. Therefore, members of the general public would always be considered under this category when exposure is not employment-related, for example, in the case of a telecommunications tower that exposes persons in a nearby residential area.

Table I and Figure I (below), which are included within the FCC’s OET Bulletin 65, summarize the MPE limits for RF emissions. These limits are designed to provide a substantial margin of safety. They vary by frequency to take into account the different types of equipment that may be in operation at a particular facility and are “time-averaged” limits to reflect different durations resulting from controlled and uncontrolled exposures.

The FCC’s MPEs are measured in terms of power (mW) over a unit surface area (cm²). Known as the power density, the FCC has established an occupational MPE of 5 milliwatts per square centimeter (mW/cm²) and an uncontrolled MPE of 1 mW/cm² for equipment operating in the 1900 MHz frequency range. For the Verizon equipment operating at 700 MHz or 850 MHz, the FCC’s occupational MPE is 2.83 mW/cm² and an uncontrolled MPE of 0.57 mW/cm². These limits are considered protective of these populations.

Table I: Limits for Maximum Permissible Exposure (MPE)				
(A) Limits for Occupational/Controlled Exposure				
Frequency Range (MHz)	Electric Field Strength (E) (V/m)	Magnetic Field Strength (H) (A/m)	Power Density (S) (mW/cm ²)	Averaging Time [E] ² , [H] ² , or S (minutes)
0.3-3.0	614	1.63	(100)*	6
3.0-30	1842/f	4.89/f	(900/f ²)*	6
30-300	61.4	0.163	1.0	6

Table 1: Limits for Maximum Permissible Exposure (MPE)				
(A) Limits for Occupational/Controlled Exposure				
Frequency Range (MHz)	Electric Field Strength (E) (V/m)	Magnetic Field Strength (H) (A/m)	Power Density (S) (mW/cm ²)	Averaging Time [E] ² , [H] ² , or S (minutes)
300-1,500	--	--	f/300	6
1,500-100,000	--	--	5	6
(B) Limits for General Public/Uncontrolled Exposure				
Frequency Range (MHz)	Electric Field Strength (E) (V/m)	Magnetic Field Strength (H) (A/m)	Power Density (S) (mW/cm ²)	Averaging Time [E] ² , [H] ² , or S (minutes)
0.3-1.34	614	1.63	(100)*	30
1.34-30	824/f	2.19/f	(180/f ²)*	30
30-300	27.5	0.073	0.2	30
300-1,500	--	--	f/1,500	30
1,500-100,000	--	--	1.0	30

f = Frequency in (MHz)

* Plane-wave equivalent power density

Figure 1. FCC Limits for Maximum Permissible Exposure (MPE)
 Plane-wave Equivalent Power Density

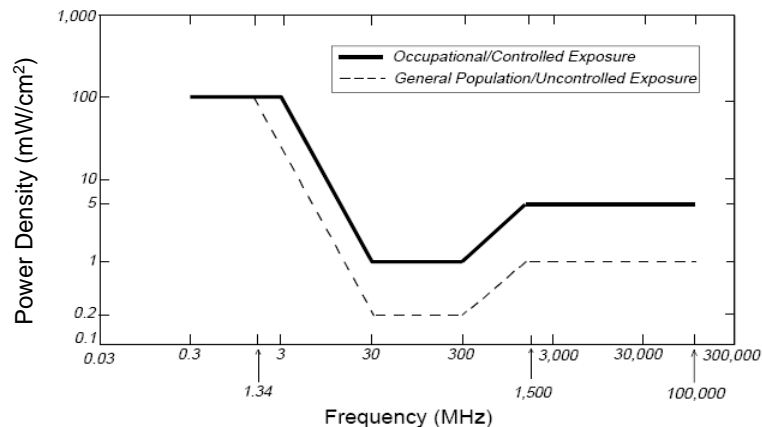

Based on the above, the most restrictive thresholds for exposures of unlimited duration to RF energy for several personal wireless services are summarized below:

Personal Wireless Service	Approximate Frequency	Occupational MPE	Public MPE
Personal Communication (PCS)	1,950 MHz	5.00 mW/cm ²	1.00 mW/cm ²
Cellular Telephone	870 MHz	2.90 mW/cm ²	0.58 mW/cm ²
Specialized Mobile Radio	855 MHz	2.85 mW/cm ²	0.57 mW/cm ²
Most Restrictive Freq. Range	30-300 MHz	1.00 mW/cm ²	0.20 mW/cm ²

MPE limits are designed to provide a substantial margin of safety. These limits apply for continuous exposures and are intended to provide a prudent margin of safety for all persons, regardless of age, gender, size, or health.

Personal Communication (PCS) facilities used by Verizon in this area operate within a frequency range of 700-2100 MHz. Facilities typically consist of: 1) electronic transceivers (the radios or cabinets) connected to wired telephone lines; and 2) antennas that send the wireless signals created by the transceivers to be received by individual subscriber units (PCS telephones). Transceivers are typically connected to antennas by coaxial cables.

Because of the short wavelength of PCS services, the antennas require line-of-site paths for good propagation, and are typically installed above ground level. Antennas are constructed to concentrate energy towards the horizon, with as little energy as possible scattered towards the ground or the sky. This design, combined with the low power of PCS facilities, generally results in no possibility for exposure to approach Maximum Permissible Exposure (MPE) levels, with the exception of areas directly in front of the antennas.

4.0 WORST-CASE PREDICTIVE MODELING

EBI has performed theoretical modeling using RoofView® software to estimate the worst-case power density at the site ground-level and nearby roof-tops resulting from operation of the antennas. RoofView® is a widely-used predictive modeling program that has been developed by Richard Tell Associates to predict both near field and far field RF power density values for roof-top and tower telecommunications sites produced by vertical collinear antennas that are typically used in the cellular, PCS, paging and other communications services. The models utilize several operational specifications for different types of antennas to produce a plot of spatially-averaged power densities that can be expressed as a percentage of the applicable exposure limit.

The modeling is based on worst-case assumptions for the number of antennas and transmitter power. The modeling assumes a maximum 3-radio configuration for the antenna with a power level of 40 watts per transmitter for the 700, 1900, and 2100 MHz frequencies, in order to provide a worst-case evaluation of predicted MPE levels. The assumptions used in the modeling are based upon information provided by Verizon, and information gathered from other sources. The parameters used for the modeling are summarized in the RoofView® export files presented in Appendix C.

There are no other wireless carriers with equipment installed at this site.

Based on worst-case predictive modeling, there are no modeled areas on any accessible ground-level walking/working surface related to the proposed Verizon antennas that exceed the FCC's occupational or general public exposure limits at this site. At the nearest walking/working surfaces to the Verizon antennas, the maximum power density generated by the Verizon antennas is approximately 6.50 percent of the FCC's general public limit (1.30 percent of the FCC's occupational limit).

The Site Safety Plan also presents areas where Verizon Wireless antennas contribute greater than 5% of the applicable MPE limit for a site. A site is considered out of compliance with FCC regulations if there are areas that exceed the FCC exposure limits and there are no RF hazard mitigation measures in place. Any carrier which has an installation that contributes more than 5% of the applicable MPE must participate in mitigating these RF hazards.

The inputs used in the modeling are summarized in the RoofView® export file presented in Appendix C. A graphical representation of the RoofView® modeling results is presented in Appendix B. It should be noted that RoofView is not suitable for modeling microwave dish antennas; however, these units are designed for point-to-point operations at the elevations of the installed equipment rather than ground level coverage.

5.0 MITIGATION/SITE CONTROL OPTIONS

EBI's modeling indicates that there are no areas in front of the Verizon antennas that exceed the FCC standards for occupational or general public exposure at ground level. All exposures above the FCC's safe limits require that individuals be elevated above the ground. In order to alert people accessing the pole, CAUTION signs are recommended for installation on opposite sides of the pole, 11' below the bottom of the antenna.

These protocols and recommended control measures have been summarized and included with a graphic representation of the antennas and associated signage and control areas in a RF-EME Site Safety Plan, which is included as Appendix B. Individuals and workers accessing the roof should be provided with a copy of the attached Site Safety Plan, made aware of the posted signage, and signify their understanding of the Site Safety Plan.

Implementation of the signage recommended in the Site Safety Plan and in this report will bring this site into compliance with the FCC's rules and regulations.

6.0 SUMMARY AND CONCLUSIONS

EBI has prepared a Radiofrequency – Electromagnetic Energy (RF-EME) Compliance Report for telecommunications equipment installed by Verizon Site Number 425102 located at 574 1st Street West in Sonoma, California to determine worst-case predicted RF-EME exposure levels from wireless communications equipment installed at this site. This report summarizes the results of RF-EME modeling in relation to relevant Federal Communications Commission (FCC) RF-EME compliance standards for limiting human exposure to RF-EME fields.

As presented in the sections above, based on the FCC criteria, there are no modeled areas on any accessible ground-level walking/working surface related to the proposed antennas that exceed the FCC's occupational or general public exposure limits at this site. Workers should be informed about the presence and locations of antennas and their associated fields. Recommended control measures are outlined in Section 5.0 and within a Site Safety Plan (attached); this plan includes procedures to shut down and lockout/tagout this wireless equipment in accordance with Verizon's standard operating protocol.

7.0 LIMITATIONS

This report was prepared for the use of Verizon Wireless. It was performed in accordance with generally accepted practices of other consultants undertaking similar studies at the same time and in the same locale under like circumstances. The conclusions provided by EBI are based solely on the information provided by the client. The observations in this report are valid on the date of the investigation. Any additional information that becomes available concerning the site should be provided to EBI so that our conclusions may be revised and modified, if necessary. This report has been prepared in accordance with Standard Conditions for Engagement and authorized proposal, both of which are integral parts of this report. No other warranty, expressed or implied, is made.

Appendix A

Certifications

Reviewed and Approved by:



sealed 31aug2017

Michael McGuire
Electrical Engineer

Note that EBI's scope of work is limited to an evaluation of the Radio Frequency – Electromagnetic Energy (RF-EME) field generated by the antennas and broadcast equipment noted in this report. The engineering and design of the building and related structures, as well as the impact of the antennas and broadcast equipment on the structural integrity of the building, are specifically excluded from EBI's scope of work.

Preparer Certification

I, Christopher Ilgenfritz, state that:

- I am an employee of EnviroBusiness Inc. (d/b/a EBI Consulting), which provides RF-EME safety and compliance services to the wireless communications industry.
- I have successfully completed RF-EME safety training, and I am aware of the potential hazards from RF-EME and would be classified “occupational” under the FCC regulations.
- I am familiar with the FCC rules and regulations as well as OSHA regulations both in general and as they apply to RF-EME exposure.
- I have reviewed the data provided by the client and incorporated it into this Site Compliance Report such that the information contained in this report is true and accurate to the best of my knowledge.







Appendix B

Radio Frequency Electromagnetic Energy

Safety / Signage Plans

% FCC Public Exposure Limit

	Exposure Level \geq 5,000
	$500 <$ Exposure Level \leq 5,000
	$100 <$ Exposure Level \leq 500
	Exposure Level \leq 100

Ground Level



 **Verizon Antennas**

Down Pole

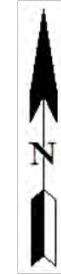
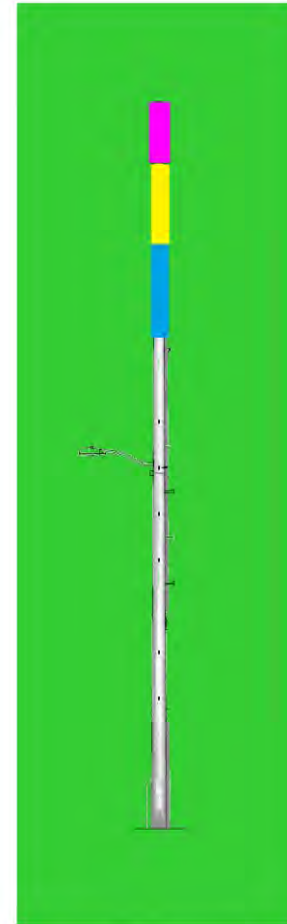

Roofview: Composite Exposure Levels

Facility Operator: Verizon Wireless

Site Name: Sonoma 012

Verizon Site Number: 425102

Report Date: 08-30-17

% FCC Public Exposure Limit

-  Exposure Level > 5
-  Exposure Level ≤ 5



 Verizon Antennas



Roofview: Verizon Exposure Levels

Facility Operator: Verizon Wireless

Site Name: Sonoma 012

Verizon Site Number: 425102

Report Date: 08-30-17

Verizon Signage Plan

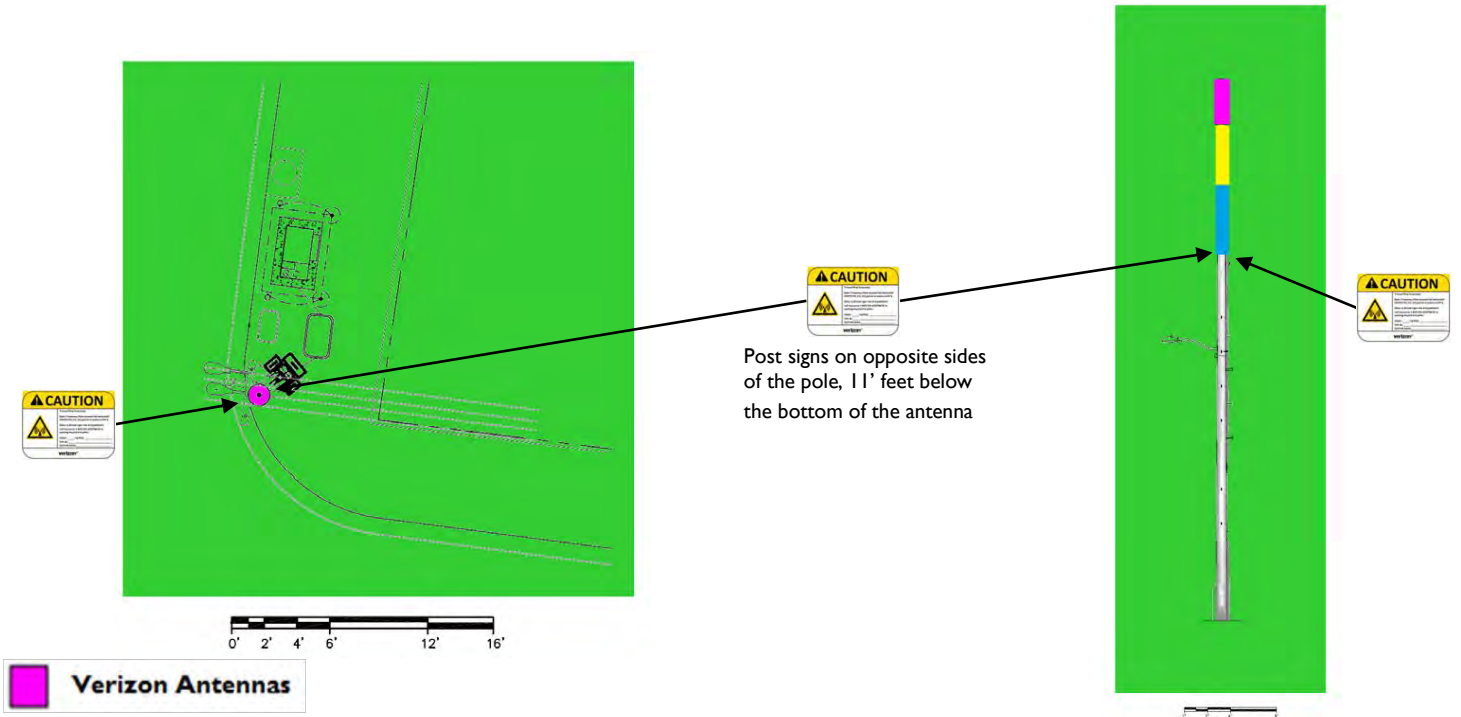

Sign Image	Description	Posting Instructions	Required Signage
	<p>Yellow Caution Sign Used to alert individuals that they are entering an area where the power density emitted from transmitting antennas may exceed the FCC's maximum permissible exposure limit for the general public and the occupational exposure limit.</p>	<p>Securely post in a manner conspicuous to all individuals entering thereon as indicated in the signage plan.</p>	<p>Post two (2) signs on opposite sides of the pole, 11' feet below the bottom of the antenna</p>

Appendix C

Roofview® Export File

StartMapDefinition

Roof Max \Roof Max > Map Max \Map Max > Y Offset X Offset Number of envelope
 120 120 140 140 20 20 1 \$AE\$81:\$E \$AE\$81:\$ETS\$200

List Of Areas
 \$AE\$81:\$ETS\$200

StartSettingsData

Standard Method Uptime Scale Fact Low Thr Low Color Mid Thr Mid Color Hi Thr Hi Color Over Color Ap Ht Mult Ap Ht Method
 4 2 1 1 100 1 500 4 5000 2 3 1.5 1

StartAntennaData It is advisable to provide an ID (ant 1) for all antennas

ID	Name	Freq	Trans Power	Trans Count	Coax Len	Coax Type	Other Loss	Input Power	Calc Power	Mfg	Model	(ft) X	(ft) Y	(ft) Z	Type	(ft) Aper	dBd Gain	BWdth Pt Dir	Uptime Profile	ON flag
VNZ A1	LTE	700	13.33333	1	0	0	1			Amphenol	CUUT070X12Fxyz0	50	50	43.33		4	9.85 70;0		ON•	
VNZ A1	LTE	1900	13.33333	1	0	0	1			Amphenol	CUUT070X12Fxyz0	50	50	43.33		4	14.35 68;0		ON•	
VNZ A1	LTE	2100	13.33333	1	0	0	1			Amphenol	CUUT070X12Fxyz0	50	50	43.33		4	14.85 65;0		ON•	
VNZ A1	LTE	700	13.33333	1	0	0	1			Amphenol	CUUT070X12Fxyz0	50	50	43.33		4	9.85 70;120		ON•	
VNZ A1	LTE	1900	13.33333	1	0	0	1			Amphenol	CUUT070X12Fxyz0	50	50	43.33		4	14.35 68;120		ON•	
VNZ A1	LTE	2100	13.33333	1	0	0	1			Amphenol	CUUT070X12Fxyz0	50	50	43.33		4	14.85 65;120		ON•	
VNZ A1	LTE	700	13.33333	1	0	0	1			Amphenol	CUUT070X12Fxyz0	50	50	43.33		4	9.85 70;240		ON•	
VNZ A1	LTE	1900	13.33333	1	0	0	1			Amphenol	CUUT070X12Fxyz0	50	50	43.33		4	14.35 68;240		ON•	
VNZ A1	LTE	2100	13.33333	1	0	0	1			Amphenol	CUUT070X12Fxyz0	50	50	43.33		4	14.85 65;240		ON•	

StartSymbolData

Sym	Map Mark	Roof X	Roof Y	Map Label	Description (notes for this table only)
Sym		5	35	AC Unit	Sample symbols
Sym		14	5	Roof Access	
Sym		45	5	AC Unit	
Sym		45	20	Ladder	



City of Sonoma

Planning Department
Revised 04/25/17

RECEIVED

SEP 01 2017

Uniform Application CITY OF SONOMA

Before submitting your application, have you checked with:

Planning Department? Building Department? Public Works Department? Fire Department?

Applicant Information

Name Verizon Wireless c/o The CBR Group

Address 841 Arnold Drive, Suite A

Phone 415.806.2323 christy@thecbrgroup.com

Owner Information

Name Northern California Joint Pole Association

Address 1800 Sutter Street, Suite 830, Concord, CA 94520

Phone 925.681.0378

Type of Application

- | | | |
|---|--|---|
| <input type="checkbox"/> Environmental Review | <input type="checkbox"/> Rezoning/Annexation | <input checked="" type="checkbox"/> Design Review |
| <input type="checkbox"/> Conditional Use Permit | <input type="checkbox"/> Rezoning:
from _____ to _____ | <input type="checkbox"/> Demolition Permit |
| <input type="checkbox"/> Conditional Use Permit (Minor) | <input type="checkbox"/> General Plan
Amendment: from _____
to _____ | <input type="checkbox"/> Certificate of Compliance |
| <input type="checkbox"/> Tentative Subdivision Map (5+ lots) | <input type="checkbox"/> Variance | <input type="checkbox"/> Lot Line Adjustment/Merger |
| <input type="checkbox"/> Tentative Parcel Map (4 or fewer lots) | <input type="checkbox"/> Exception | <input type="checkbox"/> Public Notice |
| <input type="checkbox"/> Planned Unit Development | | <input type="checkbox"/> Other: _____ |

Notice of special fees: The following special fees may also apply to your application:

- Public Notice Fee:** To cover costs associated with required newspaper and mailed public notices.
- County Processing Fee:** Applies to environmental review. Collected at application submittal.
- Fish and Game Fee:** Negative Declaration and EIR. Collected at application submittal. May be waived if project meets specific criteria.

Project Location (by address or nearest cross-street) Utility Pole Near 574 1st (Northeast corner or 1st and McDonnel), Sonoma, 95476

Assessor's Parcel Number (s) ROW

General Plan Land Use Designation ROW Zoning _____

Brief Project Description Replace existing pole and install antenna, RRUS, cables and associated equipment on new pole, cabinet to be installed at ground level within ROW adjacent to pole.

Submittal Requirements: SEE ATTACHED SHEET

I, the undersigned ("Applicant"), hereby state that I am the owner of record of the affected property or a duly authorized agent of the Property owner(s) (An agent must submit a letter of authorization signed by the property owner) and that all information submitted as part of this application is true and accurate.

I agree to the terms, conditions and obligations set forth in this Application.

I agree that I will provide written notice to the Planning Department in the event that there is a change in Applicant's interest in the property, the project, or the billing address or contact person for said project. Said Notice shall be mailed first class, postage paid, certified mail to: Planning Department, No. 1 The Plaza, Sonoma, CA 95476. Applicant shall remain responsible for all outstanding costs incurred by City.

I agree to indemnify and hold City harmless for all costs and expenses, including attorney's fees, incurred by City or held to be the liability of the City in connection with City's defense of its actions in any proceeding brought in any State or Federal court challenging the City's actions with respect to the Applicant's project.

Signature 

Date 8/31/17

**DATE STAMP WITH
APPLICATION AND
RETURN COPY TO:**

Verizon Wireless
2785 Mitchell Drive, Bldg 9
Walnut Creek, CA 94598

Attn: Small Cell Real Estate
Manager

**PLEASE DATE STAMP TOGETHER WITH
VERIZON WIRELESS APPLICATION**

**Verizon Wireless
Reservation of Rights**

We have attached Verizon Wireless's use permit application to install a wireless facility in the public right-of-way as more particularly described in the application. Please be advised that Verizon Wireless reserves all of its rights under California Public Utilities Code § 7901, the federal Telecommunications Act, Section 6409 of *the Spectrum Act* (codified at 47 U.S.C. § 1455(a)), the Federal Communications Commission ("FCC") ruling *In Re: Petition for Declaratory Ruling to Clarify Provisions of Section 332(c)(7)(B) to Ensure Timely Siting Review, Etc.*, the FCC order *In Re: Acceleration of Broadband Deployment by Improving Wireless Facilities Siting Policies, Etc.*, FCC 14-153 (FCC October 17, 2014) and associated rules codified at 47 C.F.R. § 1.40001, the licenses granted to it by the FCC, and all of its other rights that arise under any federal or state statute, regulation, or other legal authority (collectively, "Federal and State Rights"). Among other Federal and State Rights, California Public Utilities Code § 7901 grants a statewide franchise to telephone corporations such as Verizon Wireless to place telephone equipment in the public rights-of-way, and the use of the rights-of-way by telephone corporations is a matter of statewide concern that is not subject to local regulation except where such use incommodes the public use of a road or highway. In addition, the Telecommunications Act limits the authority of local jurisdictions by, among other restrictions, requiring final action within a reasonable period of time. In submitting this application, Verizon Wireless expressly reserves all of its Federal and State Rights, including, without limitation, its rights under federal and state law to challenge the requirement for a use permit for its proposed installation in the public right-of-way. Neither the act of submitting the application nor anything contained therein shall be construed as a waiver of any such rights.