

## John Abaci

---

**From:** David Storer <dstorer@sonomacity.org>  
**Sent:** Monday, April 01, 2019 12:12 PM  
**To:** Christy Beltran  
**Cc:** John Abaci; pa@mallp.com  
**Subject:** Verizon three commercial Use Permit sites in the City of Sonoma, CA  
**Attachments:** SYNDÉO smart vault details Sonoma.pdf; SYNDÉO Smart Vault Sonoma Pricing.pdf

Hi there Christy:

Hope all is well...

The City has been approached by Syndeo, a vendor offering a "Smart Vault" option for providers placing small cell facilities within the rights-of-way of municipalities like Sonoma. The information that the City has been provided (and we have confirmed can be shared with Verizon and CBR) is attached to this email. We would like CBR and Verizon to review the material and consider whether it presents a desirable option for placement of radios and associated equipment within the base of street light poles or on utility poles. This option would seem to be more cost-effective than the vault that was included in the vault analysis accompanying the 3 pending applications and would seem to address some of the concerns that have been voiced by the community as to the aesthetics of small cell facilities and even some concerns voiced by your team regarding vault installations. Notwithstanding the Syndeo design as attached, the City encourages the placement of the power/utility meter and disconnect/shut-off switch also underground with the radios - which is not currently shown in the preliminary Syndeo design.

We recognize that these are only preliminary materials and would encourage you to approach Syndeo directly regarding the "Smart Vault" option with questions that you may have. As the information is only preliminary at this time, City staff also cannot comment on any technical or design details on this option from an engineering perspective. Naturally, the Public Works Department remains interested that any equipment placed within the right-of-way (whether it be in the form of a vault, mounted on poles, or be in the form of streetlights) be the sole maintenance, cost, and legal responsibility of the provider, which would be a condition of approval that may be given for any of these facilities.

It would be our suggestion that we arrange a call for your and our team to discuss this option, as well as others which may be identified by you at this time, after you have had the opportunity to review and evaluate the attached materials. Please let me know your thoughts as to whether we may go forward in this manner. If so, perhaps we can schedule a call approximately 2 weeks out in order to get your initial impressions on this option while remaining consistent with the new processing agreement timeline.

regards,

David

916.502-7341 mobile

David A. Storer, AICP  
Planning and Community Services Director  
City of Sonoma, CA 95476



March 18, 2019

Lee Afflerbach  
Columbia Telecommunications Corp  
Royal Oak, MD

RE: Sonoma Small Cell Installation Pricing

Dear Lee,

Enclosed is the budget pricing for this project. However, real costs could fluxuate depending on finalize site analysis design, as well as, the geothermal boring depth and the related required pipe and fluid network. The intent of this pricing is to simply provide a scale of the costs.

**Materials Included:**

- Geothermal heat exchanger
- Geothermal piping loop
- Smart Vault enclosure
- Slip resistant tactilce surface panel
- H2O load rated weight bearing panel (per AASHTO M306)
- (4) Conduit entry penetrations
- 70A electrical distribution panel with (2) quad receptacles
- Wireless gateway for environmental monitoring
- Water puddle sensor
- Unistrut racking assembly

**Excluded:**

- Small cell radio brackets/attachments
- Shipping
- Taxes
- Conduit material and placement to existing infrastructure connection points (fiber or power handholes and utility pole) as well as tapping into these items
- Permits

**Pricing:** 49"x49"30" Smart Vault Assembly = \$13,010

**Budget Construction Costs:** \$10,000 - \$16,000

\*This is a wide range, but since costs can very greatly depending on local labor rates and more site specific installation details, we've given a range accordingly.

**Construction Duration:** 5-7 working days



March 18, 2019

Lee Afflerbach  
Columbia Telecommunications Corp  
Royal Oak, MD

RE: Sonoma Small Cell Installation

Dear Lee,

SYNDÉO welcomes the opportunity to further advance and illustrate how our deployment solution can assist municipalities such as the City of Sonoma in the deployment of small cells, and other 'Smart City' infrastructure assets and doing so in a more aesthetically pleasing manner. Below is a project description of the Smart Vault and justifications to support the deployment application.

**Location:**

Smart Vaults have been designed to accommodate four distinct installation locations: grass terraces, bituminous pavement, concrete sidewalks and Americans with Disabilities Act (ADA) sidewalk curb ramps. These four installation applications enable Smart Vaults to be strategically located for 'Smart City' technologies in close proximity to the users of technologies such as; IoT, small cells, traffic signal equipment, UPS and battery backup, electric vehicle charging stations, citizens broadband radio service (CBRS) and public WiFi to name a few. For this specific project the installation application illustrated is in a concrete sidewalk.

**Project Purpose:**

The purpose of this project is to provide supporting validation that the deployment of small cells is viable utilizing underground vaults, if they are designed and specified as SYNDÉO's patented Smart Vaults.

**Scope of Work:**

- Install (1) canister antenna on existing utility pole
- Install (1) 49"x49"x30" Smart Vault
- Install (2) Ericsson RRU-units inside the Smart Vault
- Install electrical distribution panel inside the Smart Vault
- Install (1) geothermal heat exchanger inside the Smart Vault connected to geothermal piping loop that will be drilled and grouted to a depth suitable to cool the RRU-units
- Install (1) utility disconnect switch mounted on the existing pole
- Install (1) electrical meter mounted on the existing pole
- Install (1) conduit from the Smart Vault to the existing pole for connection to the power equipment and canister antenna mounted on the pole
- Install sunshields on the existing pole to conceal electrical wiring
- Install, as further determined, conduits to connect into existing power and fiber handhole locations

**Antenna:**

The antenna design/type would be as per selected by the participating wireless carrier.

**Radio Units:**

The deployment illustrations contained herein have been modeled as RRU's to identically match those requested by Verizon per the "Sonoma 006" node installation.

**The Problem:**

As the growth of wireless usage has been expanding at exponential rates, and with 5G networks on the horizon, the wireless carriers need to significantly enhance their networks. Based off of the 2017 Small Cell Forum carrier study published in 2018, it is anticipated that between 250 and 875 small cells will be need, FOR EACH CARRIER, by 2020. This begs the question of where is all of this equipment going to go?

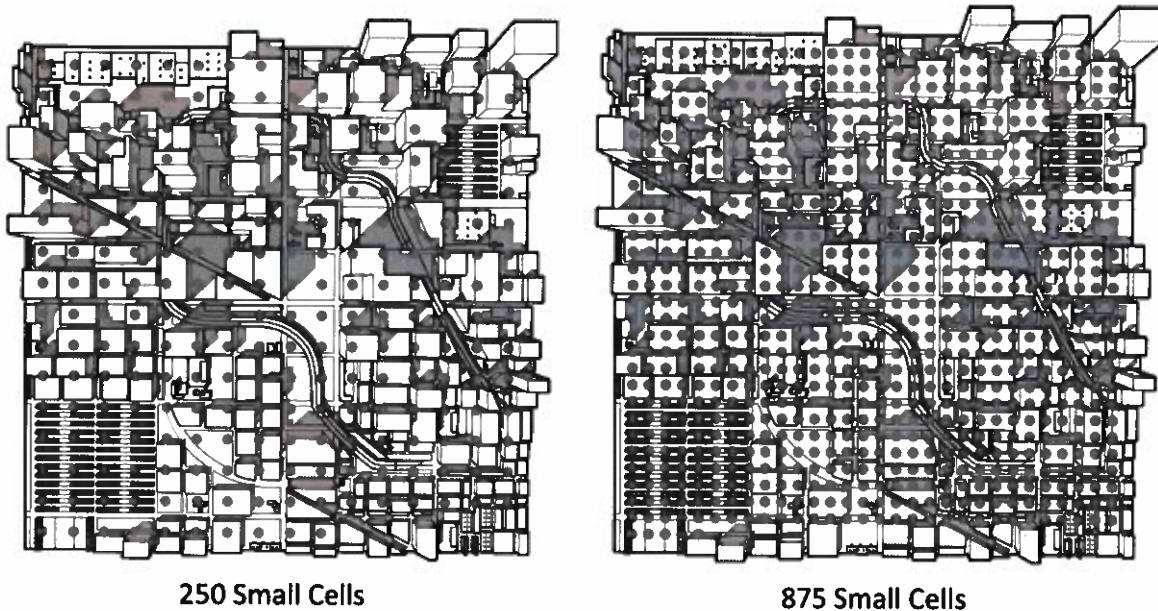

If it were strictly up to the carriers, this equipment would undoubtedly be direct mounted to existing infrastructure. While that sounds great for them, and economical, the result is a very unsightly urban landscape that is quickly overwhelmed with clutter on poles. See below for a small sampling;

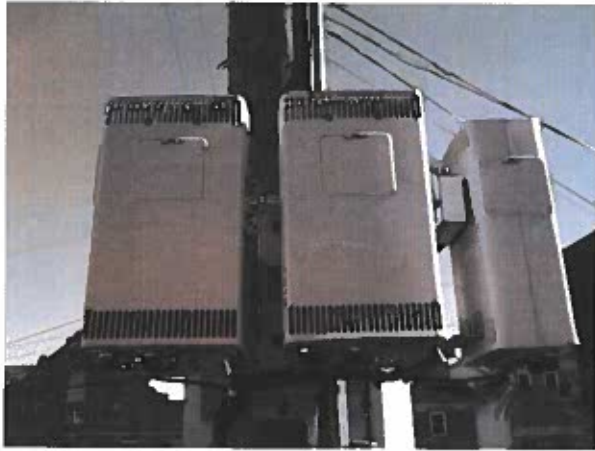

### The Solution – Small Cells:

At SYNDÉO we saw an opportunity for a cleaner deployment strategy, one that still accomplishes the wireless carrier's goal of small cell deployments while not compromising communal aesthetics. From our experience, communities aren't as bothered with the visual appearance of canister antennas on poles, rather, it's the unsightly appearance of power and fiber lines and bulky radios affixed to poles. Smart Vaults are the answer. Smart Vaults facilitate the placement of small cell radios out of sight and out of mind in underground vaults which are waterproof and environmentally controlled. Further, with the radios being in a climate-controlled environment, they should perform more reliably as they will not experience the vast night time to day time temperature swings as they would being mounted on a pole in the open environment. In addition, the Smart Vault provides the opportunity for a wireless carrier to install battery backup in the same vault as the small cell radios. This cannot be accomplished in most

situations where the small cell is placed on an existing pole. Below in the following pages are a few installation illustrations specific to the "Sonoma 006" deployment.

#### The Solution – Smart City Technologies:

SYDNÉO's Smart Vault provides a city a complete smart city technology neutral host solution. This is more than just about small cells. A few examples of other smart city solutions that can be housed in the Smart Vault include - the Smart Vault can be used to make existing decorative light poles smart by placing the Smart Vault at the base of the pole to house electronic equipment, the Smart Vault can be a home for recharging equipment connecting cars and scooters with power and data right at curbside, the Smart Vault can be the home for intelligent traffic systems equipment including traffic controllers and the Smart Vault can provide edge computing very close to urban users.

#### Construction:

Once the permitting process is complete, a licensed local utility contractor would project manage the excavation, geothermal boring and the related pipe loop, Smart Vault installation, conduit installation, backfilling and concrete work necessary for the solutions installation in strict accordance with SYDNÉO's installation instructions and city specifications. Additionally, SYDNÉO would be able to provide on-site oversight of the installation. Start to finish the installation process takes around 5-7 full working days.

\*Note – Without performing geothermal soil analysis specific to the determined site it is impossible to conclusively determine the soil type, and the related depth in which the geothermal cooling loop would need to be. However, for discussion purposes ONLY, one can figure the depth to be in the 180' depth range for the proposed heat dissipation load of 1.3kW for this project.

#### Maintenance and Monitoring:

Smart Vaults are virtually maintenance free once construction and equipment installations are completed. However, one of the key benefits of using Smart Vaults vs. pole mounted equipment is that in the event that maintenance is required, it does not necessitate the need of bucket trucks and the related vehicular traffic control measures. Rather, all equipment housed within the Smart Vault can easily be accessed off of the roadway on sidewalks with no heavy equipment needed to gain access.

SYDNÉO provides a waterproof warranty such that in the unlikely event, outside of an act of God, a Smart Vault leaks and equipment contained therein is damaged, SYDNÉO will replace said damaged equipment at no cost to the customer. Additionally, a wireless transmitting gateway, along with a water puddle sensor, is a standard component of Smart Vaults. Accordingly, should a water infiltration trip an alarm, SYDNÉO personnel will be notified and able to quickly dispatch local maintenance personnel to the site to diagnose the problem and take remedial actions if necessary. Additional monitoring equipment available are:

- Humidity & Temperature Sensor
- Photoelectric Smoke & Heat Sensor
- Motion Sensor
- Carbon Monoxide & Hydrogen Sensor

**SYNDÉO Management Experience:**

The father and son co-founding team at SYNDÉO has an extensive background in construction. Gary Henshue owned and operated an underground construction company whom employed in excess of 250 personnel installing water, sewer, gas and telecom infrastructure. Gary's company installed thousands of telecom handholes and thousands of miles of underground infrastructure.

Chris Henshue is a 2004 graduate of the University of Wisconsin-Madison obtaining a degree in Civil Engineering with a certificate in Construction Management. With his engineering and construction background Chris was a project manager working for large general contractors building hospitals, clinics and surgery centers across the U.S.

The Henshue's have authored and have been issued over a dozen patents in the U.S., and internationally, for detectable warning panels to assist the visually impaired in safe wayfinding, and the 'Smart City' enabling product that has come to be known as the Smart Vault.

**Smart Vault Illustrations:**

See below for detailed installation, and project specific illustrations for the "Sonoma 006" application. Additionally, a three dimensional model can be found by selecting here: <https://skfb.ly/6IDqy>

## Deployment Components

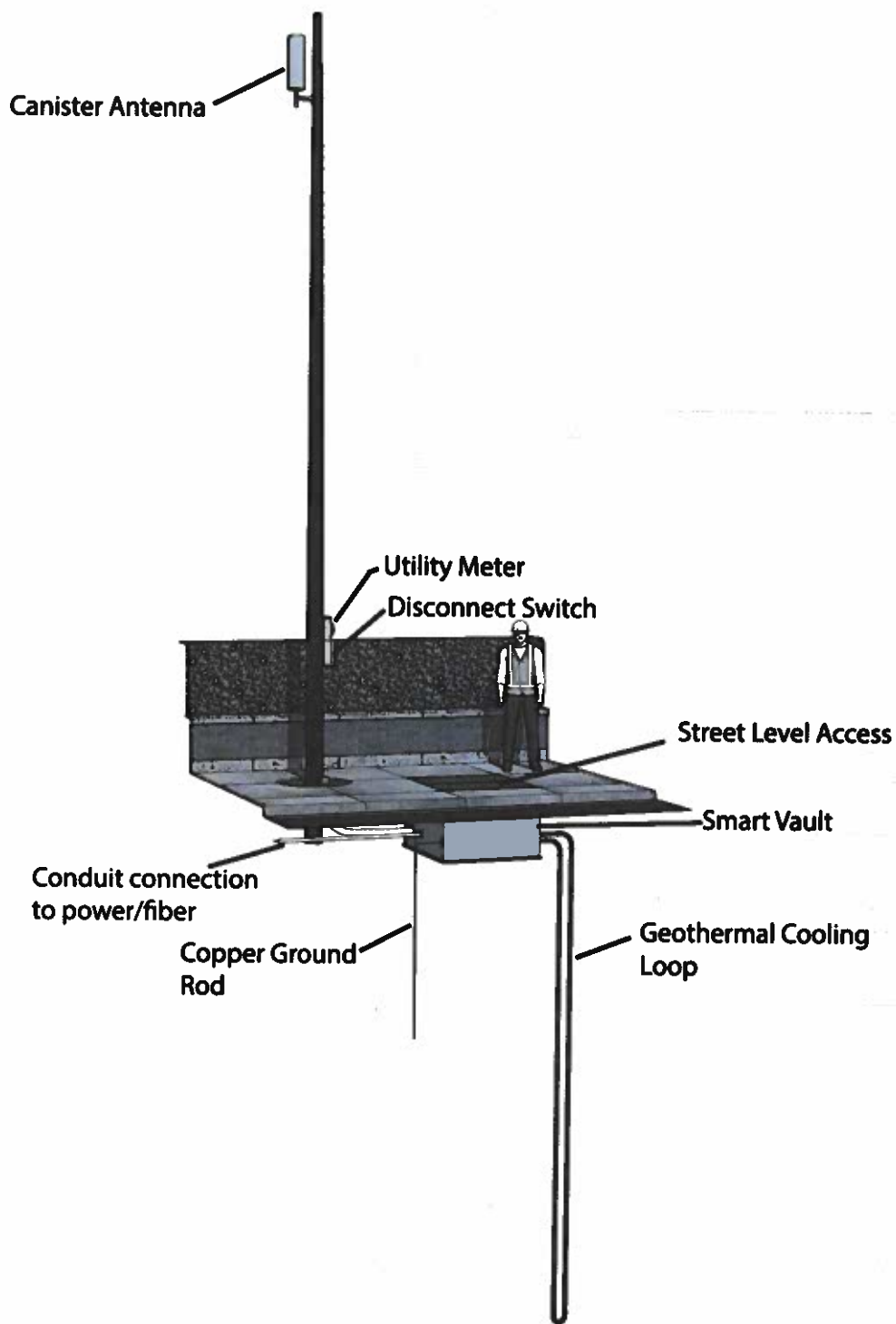



Street Level View

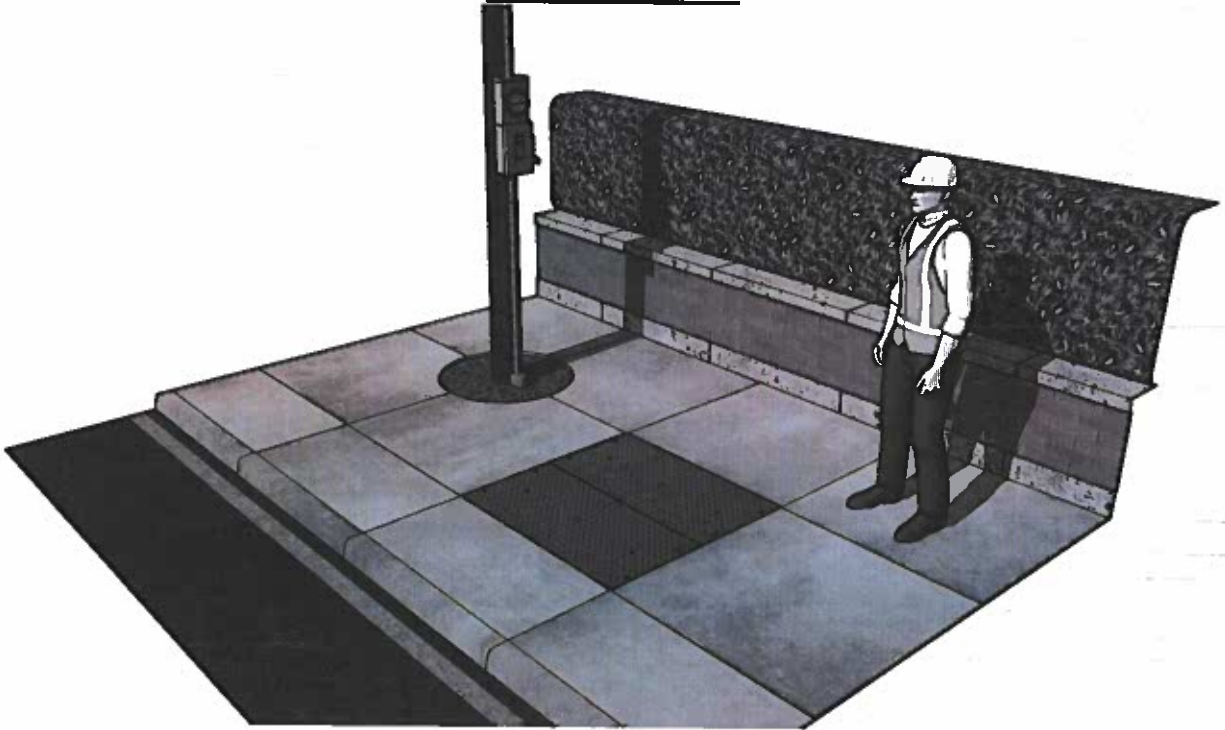

Street Level Access

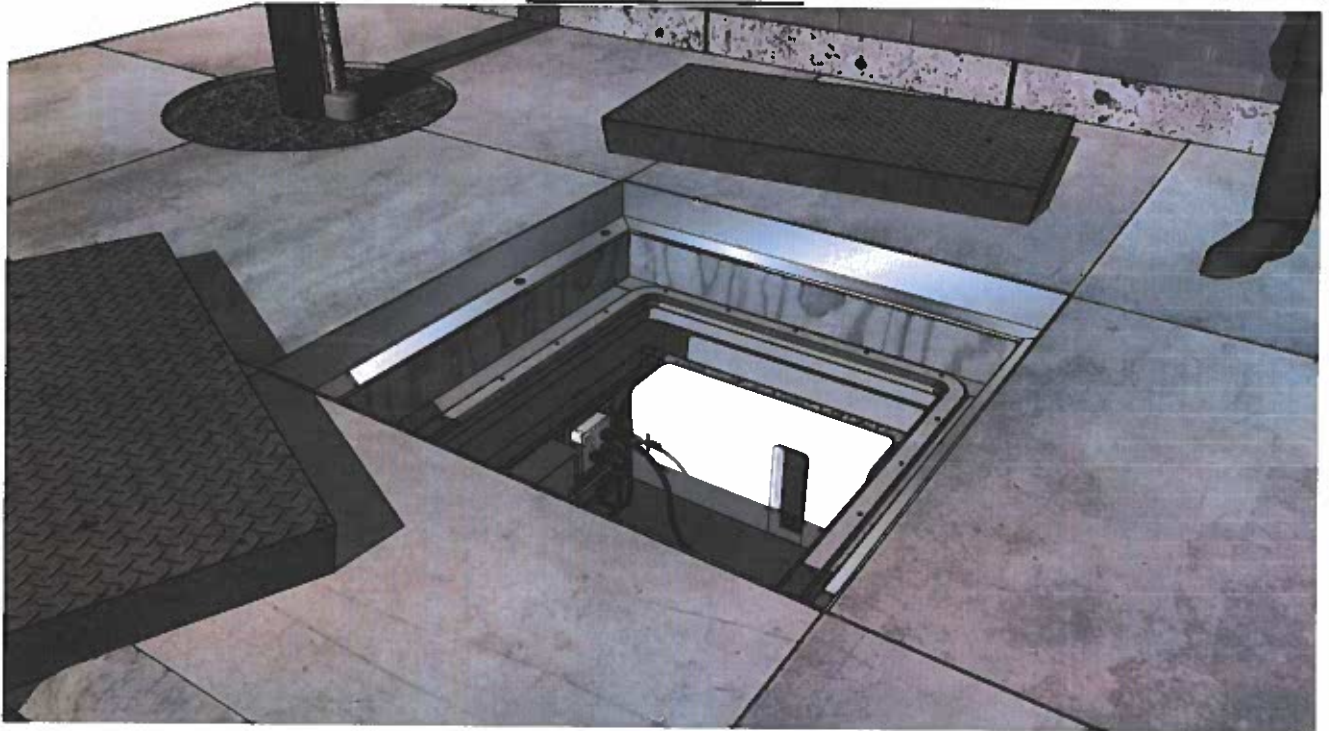

### Smart Vault Section View

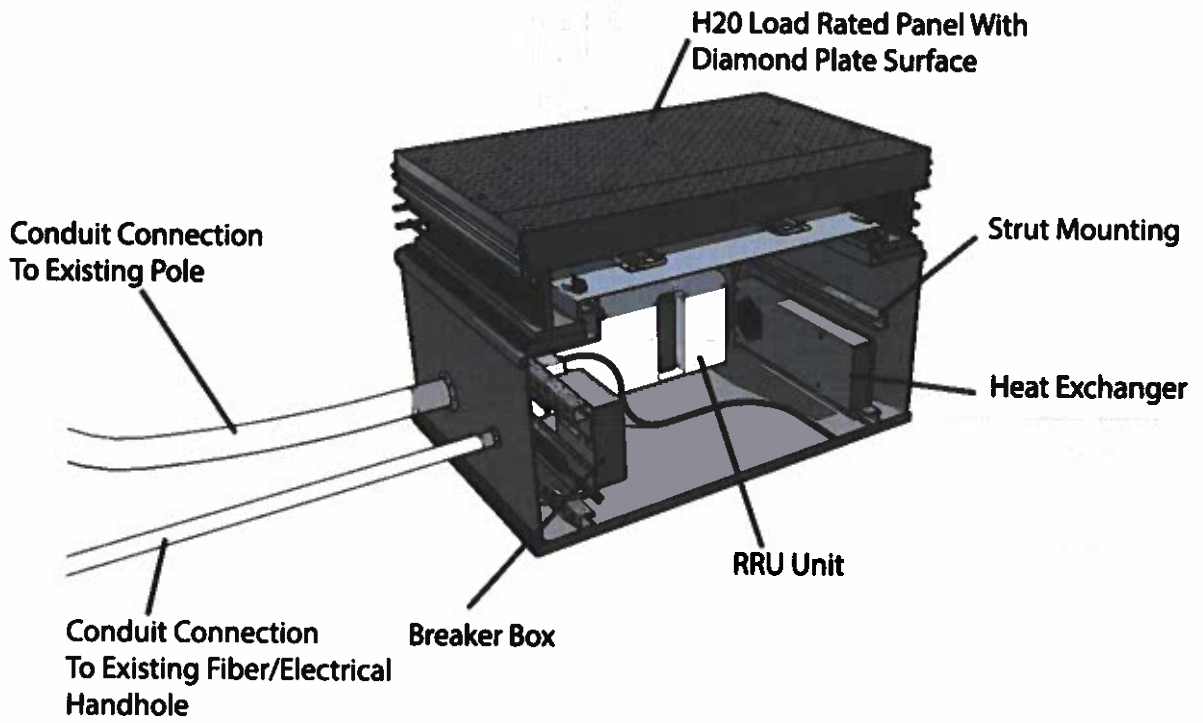

### Smart Vault Unistrut Racking Detail 1

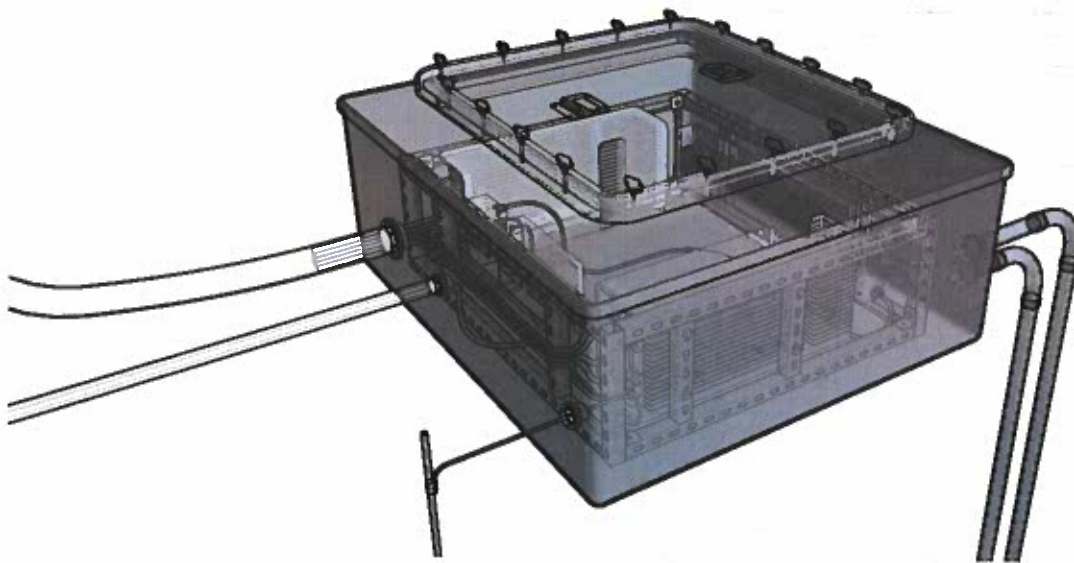

Smart Vault Unistrut Racking Detail 2

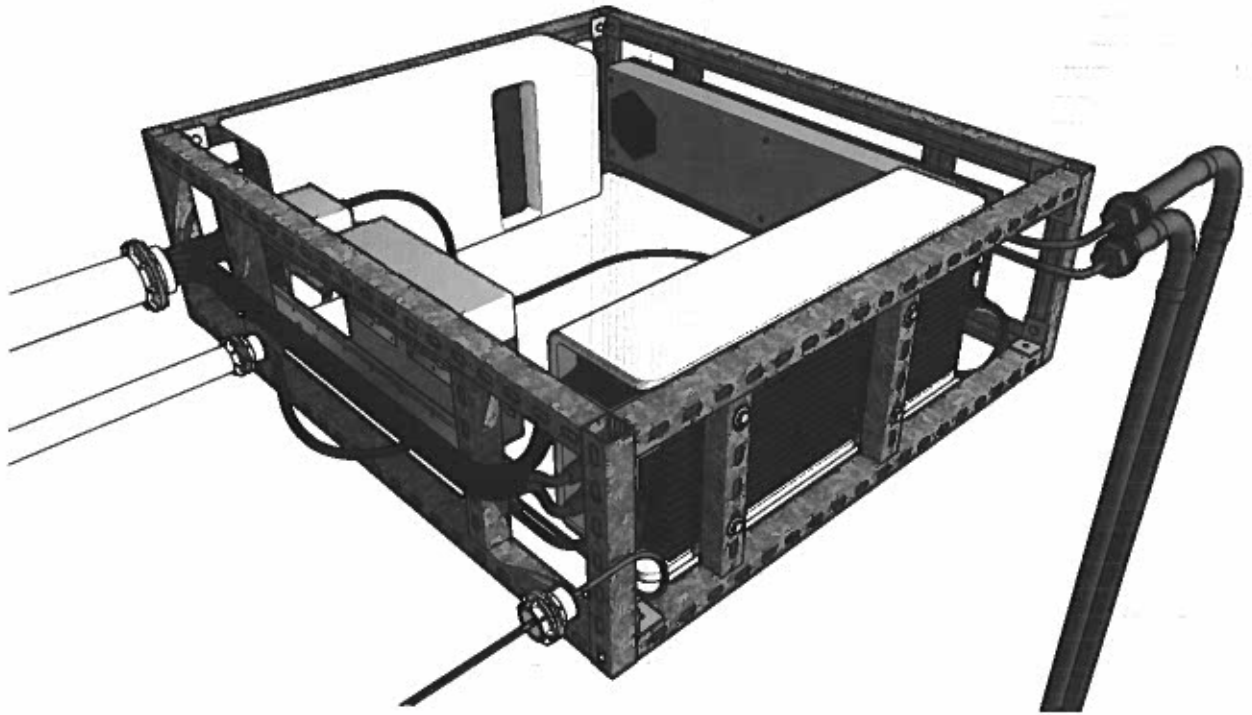

# Equipment Layout Plan View

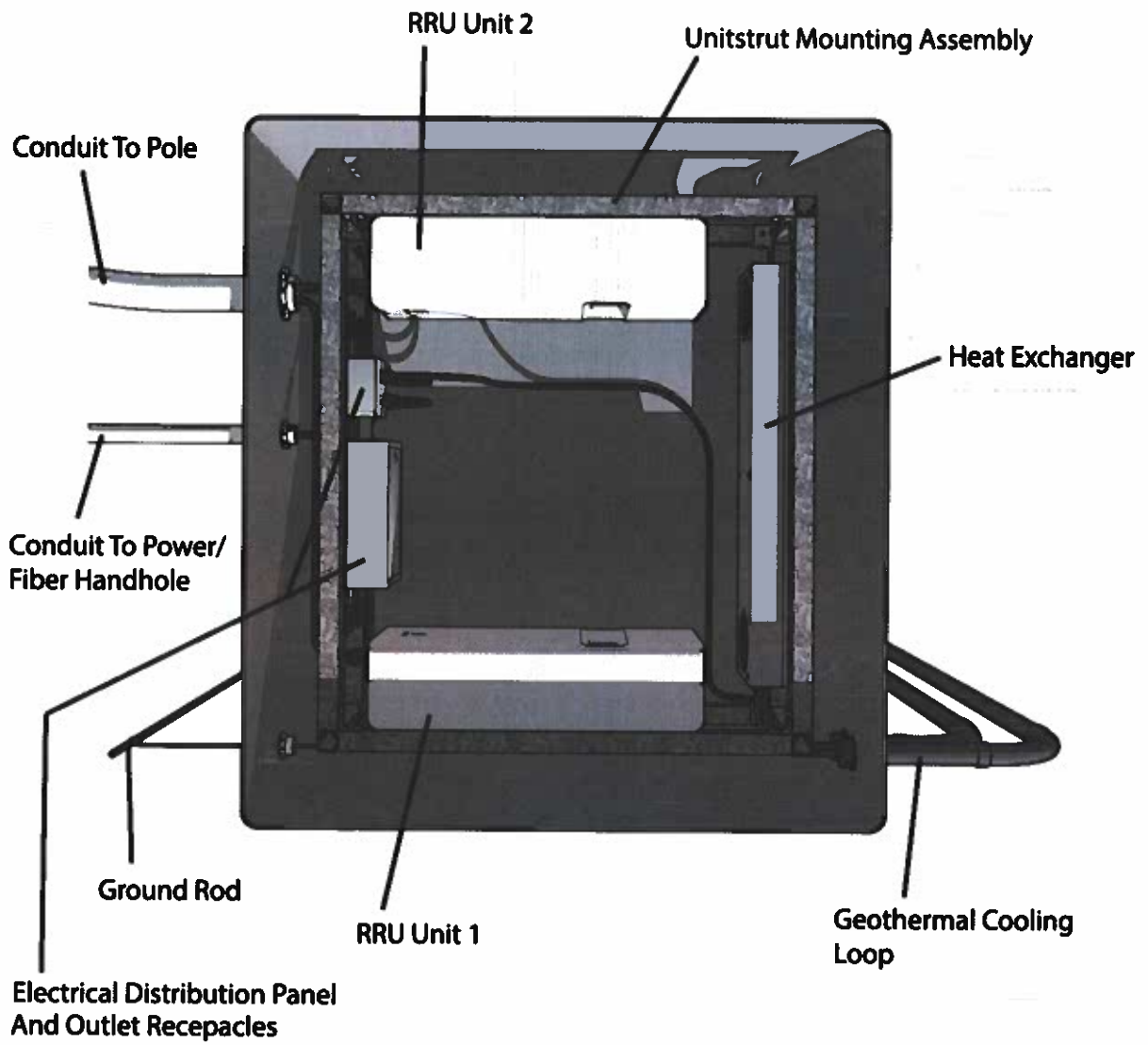

May 1, 2019

Paul Albritton  
Mackenzie & Albritton LLP  
155 Sansome Street, Suite 800  
San Francisco, CA 94104  
BY EMAIL TO [pa@mallp.com](mailto:pa@mallp.com) AND REGULAR MAIL

Re: Verizon small cell applications in City of Sonoma

Dear Paul:

Following our meeting with your team last Friday the City group discussed the next proceedings in the 3 applications made by the CBR Group firm/Verizon Wireless in the commercial districts in more detail. At that time it was agreed that the July 11 date agreed upon by your group as being the date at which CBR/Verizon would be bringing various potential designs before the Planning Commission should be a workshop proceeding, rather than a public hearing. The public hearing on the final designs which would be submitted following the workshop by CBR/Verizon would be scheduled for the second week of September. If a second meeting of the Planning Commission is required for a determination to be made, then it would be completed by November 15. If an appeal is made to the Planning Commission's determination, then it would be within 90 days of the date that the Planning Commission makes its determination. Thereafter, upon the final determination being made, Verizon shall have 30 days to notify the City whether it intends to go forward with the 7 small cell applications in residential districts. If notice is not provided within that timeframe, then the applications shall be deemed withdrawn.

I believe that this substantially reflects our understanding at the end of the meeting with your team last Friday, in that CBR/Verizon would still have the opportunity to place the designs it is considering before the Planning Commission for the members' individual comments prior to submitting its final designs for these applications. Although we did not specifically address the period for a determination to be made on an appeal to the Planning Commission, the time period of 90 days from the date of the Planning Commission's final determination (which could be as early as the second week of September and no later than November 15) is being incorporated. Since the ensuing dates could not be given with much specificity, instead of trying to establish a specific date for residential applications to be considered, the timeframe of 60 days is being applied to both the Planning Commission and appeal hearing dates. These would be less than the 90-day periods applicable to the first 3 applications, as we are currently developing a process with these first 3 applications that would likely be utilized with the balance of the applications as well and therefore we would anticipate less time being needed. As these additions do not seem to alter the intent or spirit of our agreement last Friday, I don't believe that they should affect your client's willingness to enter into an agreement to modify the Third Amendment accordingly.

In anticipation of your acceptance of these provisions, I have gone ahead and drafted another amendment to the processing timeline as I stated I would during our meeting except that I have included the terms outlined above within the amendment.

670 W. NAPA STREET, SUITE F, SONOMA, CALIFORNIA 95476  
TELEPHONE: 707-996-9690 FAX: 707-996-9603



**FILE COPY**

As a second matter, following our meeting last Friday the technical consultant, CTC, did contact Syndeo, the manufacturer of the smart vault design that was previously shared with Verizon. CTC was told that the company had not been contacted by CBR or Verizon regarding the smart vault. On the other hand, CBR had stated at our meeting that they had reached out to Syndeo but did not get a response. In order to facilitate communications between CBR and Syndeo, we've obtained the following name and contact information for an individual at Syndeo who can discuss the smart vault with CBR/Verizon directly and will be expecting to hear from CBR and/or Verizon: Chris Henshue 608-575-8818 [chrish@syndeocities.com](mailto:chrish@syndeocities.com) . Please forward this information to CBR/Verizon.

Attached is the Fourth Amendment to August 6 Processing Agreement. Please indicate your client's acceptance by executing the agreement and returning it to me at your earliest convenience. Otherwise, if you have any questions or wish to discuss these terms, please contact me at the below telephone number or my email address.

Sincerely,



John Abaci  
Assistant City Attorney