



### Kitchen Remodel Submittal Requirements

Handout No: 22  
Revised 9/25/21

#### **REQUIREMENTS FOR PERMIT SUBMITTAL:**

***Before approval and issuance of a building permit for a kitchen remodel, the applicant must submit three (3) sets of plans (preferred size - 36" x 24"; minimum size - 17" x 11"), which are drawn to scale (1/4" per ft. min.) using architectural drafting techniques and are fully dimensioned with easily readable notations, text and symbols. The sheets should be numbered and readable in landscape orientation. See the Helpful Information handout "[Drafting Technique and Plan Symbols](#)" on the City's web site for more information.***

***The plans should include the following information:***

- 1) **Cover Sheet** including the following: (a) project address; (b) owner's name, address, phone number; (c) name, address and phone number of the person preparing the plans, (d) scope of work statement; (e) sheet index indicating each sheet title and number, (f) legend for symbols, abbreviations and notations used in the drawings.
- 2) **Site Plan** for any new exterior additions please specify lot dimensions and clearly indicate the distances from the building to property lines. (Note: if all work will be performed within the existing building, no site plan is typically necessary.)
- 3) **Existing Floor Plan** of the home to show where the remodeled kitchen is located and its existing layout. Specify the existing use of all rooms and areas. (Note: The existing floor plan is needed for reference purposes only).
- 4) **Proposed Kitchen Floor Plan** showing type and location of proposed cabinetry, countertops, appliances, plumbing fixtures, etc. Indicate (N) for new items and (E) for existing items of work. Include a construction legend identifying and describing new work and clearly showing all existing and proposed conditions.
- 5) **Exterior Windows or Glass Exterior Doors Added and/or Replaced** as part of the remodeling project shall be clearly identified on the plans, including the type of window operation, the fenestration U-Factor and Solar Heat Gain Coefficient (SHGC) and must be accompanied by a 2019 CF1R-Alt-01-E or 2019-CF1R-ALT-05-E energy form. [California Energy Efficiency Code (ENERGY) Sec.110.6]
- 6) **Water-Conserving Plumbing Fixtures** must be provided for homes built and available for use or occupancy on or before January 1, 1994. This applies to all noncompliant plumbing fixtures within the home regardless of the area being remodeled. [California Civil Code Sections 1101.1-1101.8]
  - If existing **toilets** use more than 1.6 gallons of water per flush, they must be replaced with toilets having not more than 1.28 gallons per flush.
  - If existing **showerheads** use more than 2.5 gallons of water per minute, they must be replaced with showerheads having not more than 1.8 gallons per minute maximum flow.
  - If existing **lavatory faucets** use more than 2.2 gallons of water per minute, they must be replaced with lavatory faucets having not more than 1.2 gallons per minute maximum flow.
  - If existing **kitchen faucets** use more than 2.2 gallons of water per minute, they must be replaced with kitchen faucets having not more than 1.8 gallons per minute maximum flow.

- 7) **Construction details** for any new/reframed interior walls, interior/exterior openings, etc.
- 8) **Interior Elevations** of the kitchen cabinets are helpful but not usually required.
- 9) **Electrical Plan** (may be combined with the floor plan) showing compliance with the following requirements. Show all electrical fixtures, switching, receptacles, appliances, fans, smoke and carbon monoxide detectors, services and electrical equipment. Specify required GFCI and AFCI circuits. Provide light fixture and lighting control legend and schedule and show all light fixture switching configurations, occupant sensors, dimmers and other lighting control devices and specify fixtures that conform to the mandatory energy requirements and energy documentation. Specify size of electrical service.:
  - A. Show and specify receptacle outlets at each kitchen counter space wider than 12", located so that no point along the counter wall is more than 24" from a receptacle per California Electrical Code (CEC) Art.210-52 (C) 1;
  - B. Show and specify at least one receptacle outlet at each island or peninsular counter space with a long dimension of 24" or greater and a short dimension of 12" or greater per CEC Art.210-52(C)(2) & (3);
  - C. Show and specify that all new electrical outlets within 6 feet of a sink or that supply dishwashers or that serve countertop surfaces in kitchens shall be GFCI protected (CEC Arc.210-8).
  - D. Specify at least two separate 20-amp circuits for small kitchen appliances. Note: kitchen appliance circuits are limited to supplying wall and counter space outlets only. [CEC Art.210-52(B)].
  - E. Specify that all new receptacles on 120- volt 15- and 20-amp circuits shall be listed tamper-resistant except when located more than 76 inches above the floor or within casework, or when part of a luminaire or appliance [CEC 406.12].
  - F. Lighting and Lighting Controls must be shown and must comply with the following CA Energy Code requirements:
    - Show and specify that all installed luminaires shall be high-efficacy in accordance with CA Energy Code Table 150.0-A. If screw based luminaires will be installed, specify that the lamps shall be marked "JA8-2016" or "JA8-2016-E". All screw based luminaires shall be controlled by dimmers or manual-on vacancy sensors. [Energy 150.0(k)1.G & 150.0(k)2.K]. Low efficacy lighting (i.e. halogen, incandescent, etc.) is not allowed. [Energy 150.0(k)1.A.]
    - Specify that newly installed recessed downlight luminaires shall not contain screw based sockets. [Energy 150.0(k)1.C]
- 10) **Smoke Alarms:** Show location of all smoke alarms throughout the home. Building permits for alterations with a permit valuation exceeding \$1,000 require installation of smoke alarms in the following locations:
  - (a) in each sleeping room, and
  - (b) at a point centrally located in the corridor or area giving access to each separate sleeping area, and
  - (c) on each additional story and in the basement (if any).Smoke alarms shall receive their primary power from the building wiring, shall have a 10-year battery backup and shall be interconnected with all other smoke alarms to be clearly audible in all bedrooms except in existing areas of buildings undergoing alterations or repairs that can't be installed without the removal of interior finishes. Physical interconnection is not required where listed wireless alarms are installed.  
[CBC 907.2.11 and CRC R314]

- 11) **Carbon Monoxide Alarms:** Show location of all carbon monoxide alarms throughout the home. Building permits for alterations with a permit valuation exceeding \$1,000 require installation of carbon monoxide alarms when the existing dwelling or sleeping unit has an attached garage or a fuel-burning appliance. Carbon monoxide alarms are required in the following locations:
- (a) outside of each separate dwelling unit sleeping area in the immediate vicinity of the bedroom(s), and
  - (b) on each level of a dwelling unit including basements.
  - (c) In any bedroom where a fuel burning appliance is located within the bedroom or its attached bathroom.

Carbon monoxide alarms shall receive their primary power from the building wiring, shall have a 10 year battery backup and shall be interconnected, except in existing areas of buildings undergoing alterations or repairs that can't be installed without the removal of interior finishes. (for exceptions see code). Specify the location of all carbon monoxide alarms on the plans. [CBC 907.2.11 and CRC R315]

- 12) **CALGreen.** If the remodel includes an addition of floor area, size or volume to the existing home, CALGreen checklist documentation must be submitted. The applicable checklist can be downloaded on from the City's web site.
- 13) **Required Public Improvements:** When the cumulative valuation of work for all permits for a property is \$50,000 or more within any 24-month period of time, Chapter 12.14 of the Sonoma Municipal Code (SMC) requires the construction of curb, gutter, sidewalk, storm drains and other necessary drainage facilities or any other public improvements required for the street frontage of your property, along with any needed right-of-way and/or easement dedications to the public. The construction of vehicle parking lots and any other improvement to buildings or real estate shall constitute an improvement for which a building permit shall be required. If some public improvements already exist but do not meet existing city standards and are considered by the city engineer to be a hazard to health and safety of the general public, these improvements shall be reconstructed to existing city standards. Engineered plans prepared by a registered civil engineer showing the required improvements may be required if determined necessary by the city engineer. No occupancy permit for any building shall be approved or issued unless the required public improvements have been installed and accepted by the city engineer. Projects consisting solely of reroofing, ADA upgrades, thermal solar water heaters, solar photovoltaic electrical systems, energy storage systems, electric vehicle charging stations, or emergency standby generator installations, or permits with a total permit valuation of \$50,000 or less within any two-year period are exempt from triggering the requirement of public improvements. For a determination of necessary public improvements, please contact the Public Works Inspector at (707) 938-3681.
- 14) **Fire Sprinklers Required:** An automatic fire sprinkler system is required for existing residential buildings upon a remodel or addition when any of the following conditions occur (CFC 903.2 as amended):
- a. The addition of floor area to a building results in a total floor area for the building of 4,000 square feet or more; or
  - b. The addition of floor area to a building results in a total floor area for the building of ten percent (10%) or more of the existing floor area of the building; or
  - c. The cumulative total building permit valuation for all building permits issued for the subject building within any 36-month period, as determined by the Building Official, is more than \$100,000.

Exception: Accessory Dwelling Units and Junior Accessory Dwelling Units, as defined in SMC Section 19 .92.020, that meet the requirements of SMC Section 19.50.090 and the

existing primary residence does not have installed and is not required to install an automatic residential sprinkler system.

When required, fire sprinkler plans and calculations may be submitted under a separate permit application. Three (3) sets of fire sprinkler plans, two sets of calculations, and two sets of cut sheets for the fire sprinkler heads should be submitted with your application for a fire sprinkler permit.

**ELECTRICAL LEGEND**

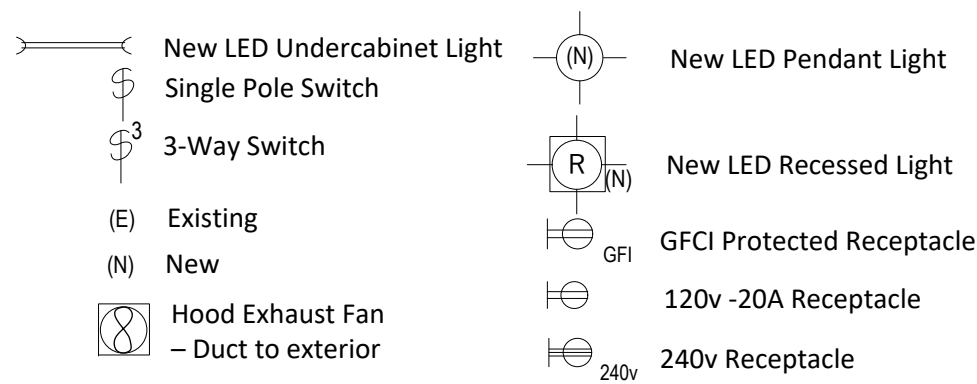

**ELECTRICAL NOTES**

1. All new screw based luminaires shall be JA8 certified.
2. New recessed luminaires shall not have screw based lamp holders.
3. All newly installed luminaires shall be high efficacy.
4. All new 120v 15- and 20-ampere kitchen circuits shall have Arc-Fault Circuit Interruption (AFCI) protection.

**SCOPE OF WORK:**

Remodel kitchen as shown and indicated. All casework, fixtures and appliances are located in the same location as existing unless otherwise noted.

**ALL NONCOMPLIANT EXISTING PLUMBING FIXTURES** in the existing home (including bathrooms) must comply or be upgraded to water conserving fixtures in accordance with CA Civil Code Sections 1101.1-1101.8. (exceptions may apply)

**FLOOR PLAN KEY NOTES:**

- 1 Remove and replace kitchen flooring with new wood laminate flooring.
- 2 Remove and replace 5/8" drywall ceiling as needed to install electrical.
- 3 Existing wall framing to remain. Remove and replace 1/2" drywall as needed for electrical
- 4 Add new double oven.
- 5 Remove and replace existing range with new cooktop. Provide new hood and exhaust fan.
- 6 Remove and replace existing sink with new sink, garbage disposal, and 1.8 max. GPM faucet.
- 7 Add new dishwasher with electrical disconnect under sink and airgap at sink.
- 8 Remove and replace existing upper cabinets with new upper cabinets.
- 9 Remove and replace existing lower cabinets and counter tops with new lower cabinets and counter tops.
- 10 Remove and replace existing refrigerator with new refrigerator.
- 11 Existing window to remain.
- 12 Add new island cabinet and counter.
- 13 Remove existing non-bearing wall.

**SMOKE ALARMS** shall be installed in the following locations in accordance with CRC Section R314:

- In each sleeping room.
- Outside each separate sleeping area in the immediate vicinity of the bedrooms.
- On each additional story of the dwelling, including basements and habitable attics, but not including crawl spaces and uninhabitable attics. In dwellings or dwelling units with split levels and without an intervening door between the adjacent levels, a smoke alarm installed on the upper level shall suffice for the adjacent lower level, provided that the lower level is less than one full story below the upper level

**CARBON MONOXIDE ALARMS** shall be installed where fuel-burning appliances are installed and in dwelling units that have attached garages. Carbon monoxide alarms shall be installed in the following locations (R315):

- Outside of each separate dwelling unit sleeping area in the immediate vicinity of the bedroom(s).
- On every level of a dwelling unit including basements.
- In every bedroom where a fuel burning appliance is installed in the bedroom or its attached bathroom.

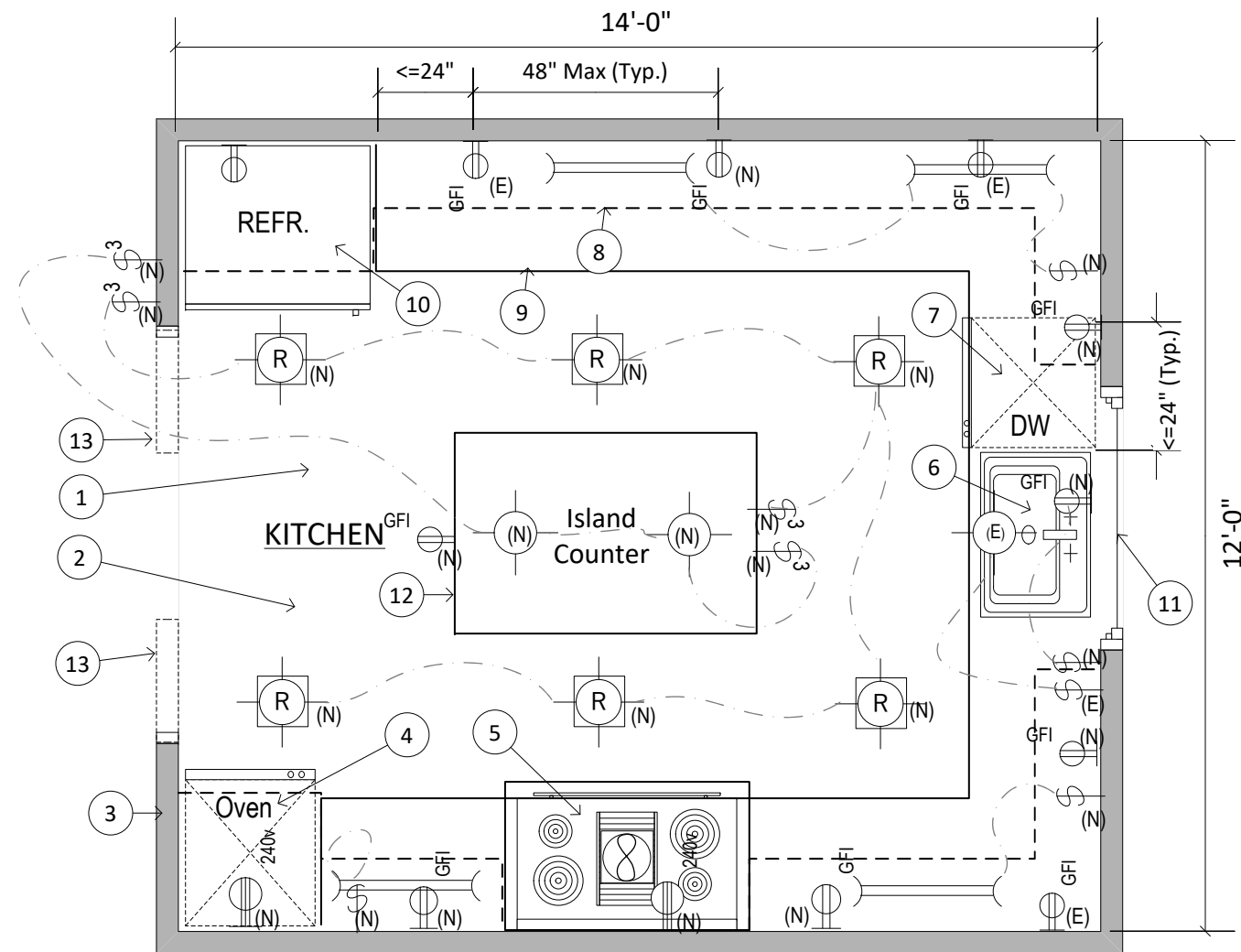

**SAMPLE - KITCHEN REMODEL FLOOR PLAN**

Scale: 3/8" = 1'-0"

**Project Address: 123 Main Street**

All new work must comply with the:

- 2019 CA Residential Code (CRC)
- 2019 CA Electrical Code (CEC)
- 2019 CA Plumbing Code (CPC)
- 2019 CA Mechanical Code (CMC)
- 2019 CA Energy Code &
- 2019 CA CALGreen Code as applicable and amended by the Sonoma Municipal Code.

Owner Name: Joe Remodeler  
 Address: 123 Main Street,  
 Sonoma, CA 95476  
 Phone: (999) 999-9999  
 E-mail: Joe@email.com

**Project Address  
 123 Main Street**

Plan Date : 1/28/20  
 Revision Date:

(Space for "APPROVED" stamp)