



CITY OF SONOMA

TEMPORARY PARKLETS & SIDEWALK EXTENSION GUIDE

Contacts:

Wendy Atkins

WAtkins@Sonomacity.org

PH: 707.933.2204



Sonoma has always valued its small-town character which is supported by small unique businesses, many of which have been home grown in the Sonoma Valley. Unfortunately, in March of this year, the coronavirus dramatically affected how we live, our public health and the economy. For Sonoma County, State guidance has closed restaurants for indoor dining, increasing the need for outside dining space. While this may change over time, the current guidelines limit restaurant capacity to no more than 50% even when at the least restrictive State public health tier. As we enter the winter months, there is a need to provide greater space, easily accessible and off the Plaza lawn. The overall goal of this Guide is to provide a clear process and pre-approved plans for the use of parklets and pedestrian pathways to provide additional outdoor spaces for business operation and physical distancing.

In response to this public health emergency, the City Council directed City staff to work collaboratively and creatively with our local businesses in addition to the Sonoma Valley Chamber of Commerce, the Sonoma Valley Visitors Bureau and the Sonoma Valley Vintners & Growers Alliance. On May 18, 2020, Sonoma City Council authorized the City Manager to create and implement new re-opening and recovery measures through the issuance of Temporary Use Permits, Encroachment Permits, and/or Licensing Procedures to allow the City's businesses to expand their operating space utilizing public sidewalks, the Plaza, Grinstead amphitheater, public rights-of-way (including parking areas and roadways), their own property or neighboring properties with neighbor agreement, while respecting social distancing requirements. The City Council also waived fees associated with these actions.

The City started these expansion opportunities by approving the use of sidewalks, alleys and private property. Several downtown restaurants have received City approval to set up tables and provide food and beverage service in areas on public sidewalks. The Plaza was also opened for use by restaurants and tasting rooms. Pedestrians have provided valuable input regarding the need to provide room for people to feel safe when walking in these areas.

Sonoma businesses can now apply for a temporary parklet to make use of parking spaces on the City street adjacent to the business. The following guidelines will allow the utilization of traditional parking spaces to allow for business expansion opportunities for restaurants and tasting rooms that have severe restrictions on indoor seating and/or limited outdoor expansion on their own site. The investment in renting or constructing these amenities is significant and will require review and approval of the City of Sonoma to ensure safety, aesthetics and other public issues. These guidelines will be updated overtime, the most up to date version of the guidelines are found on the City of Sonoma website <https://www.sonomacity.org/sonoma-al-fresco/>. It is important to note the City of Sonoma is granting approval for the parklets, but the Public Health Department and the State of California continue to have oversight over outdoor dining.

Cathy Capriola
City Manager, City of Sonoma

ALLOWABLE CONFIGURATIONS

ALLOWABLE CONFIGURATIONS

The following configurations are allowed for Sonoma (*Each parklet would require various safety and design items. These are considered a sidewalk extension per State codes*).

City will determine the number of spaces designated per business and the configuration. Each location is unique and requires individual review.

- Parallel Parklet -- Utilizing Parallel Parking Spaces – These spaces are limited to East Spain Street, East Napa Street (excluding the CalTrans right-a-way), and 1st Street West at this time. The approximate depth of usable space from the curb is 7’.
- Diagonal Parklet -- Utilizing Diagonal Parking Spaces – These diagonal spaces are directly around the Plaza. In order to support restaurants efficiency and effectiveness, these new parklets need to be adjacent to the restaurants as much as possible and can range in size between 2-6 parking spaces. The approximate depth of usable space from the curb 14’.
- Sidewalk Extensions Utilizing Parallel Parking Spaces -- These spaces are limited to East Spain Street, East Napa Street, West Spain Street, and 1st Street West at this time. The Sidewalk Extension (Pedestrian Pathway), allows for the potential to add seating to the sidewalk while creating a safe route for pedestrians to travel out and around the service area of the sidewalk. Sidewalk extensions must accommodate accessibility requirements, in the form of a raised platform.

Cal Trans has authority over Highway 12 abutting the Plaza and downtown and no use of the parking areas is allowed at this time. The City has advocated with Cal Trans and the Governor’s Office to create more flexibility on these spaces.

EXPIRATION OF PARKLETS

The City has received approval from City Council to extend the use of a temporary parklet through November 2021 with the possibility of an extension. Even if the pandemic is completed earlier, the City would provide the restaurants a choice to continue to have extra outdoor space in the form of a parklet, to try to serve more people and “catch-up” on past revenue losses.

GENERAL SAFETY REQUIREMENTS

- Parklets should not be located in front of red painted curbs, fire hydrants, fire department connections, catch basins or within 20 feet of a street corner.
- Parklets must be designed for ADA (Americans with Disabilities Act) compliance.
- Parklets are not required to have a platform, but equal ADA access will need to be provided if parklet is not ADA accessible.
- The parklet platform frame should be a freestanding structural foundation that rests on the street surface or curb. If features or structural components need to be attached to the street, curb, or adjacent planting strip then they can go no deeper than 6" with City Public Works approval .
- In no case shall any portion of the parklet, or any furniture placed upon it, obstruct the view of a traffic control device.
- Businesses must maintain the quiet, safety, and cleanliness of the parking lane space and its adjacent area.



SAFETY REQUIREMENTS

City staff working closely with the City Engineer and the City Traffic Engineer will devise a plan to address the specific needs of each location.

City of Sonoma will install traffic safety devices

- Wheel stops one foot from the curb line.
- Safety elements are required.
- Reflective channelizers at the outside corners of the parklet and along the travel lane.
- Water wall barriers on both ends of the parklet and in some cases along the traffic lane as determined by Public Works and the City's Traffic Engineer.

Business Owner will need to ensure:

- Parklet shall not block gutter storm water drainage, fire hydrants, driveways, manholes, or public utility valves/covers.
- Solid perimeter railing
- Parklets must be designed for ADA (Americans with Disabilities Act) compliance.
 - At least 5% and not less than one dining seating space shall be made accessible to disabled individuals (e.g. 30"x48" min. clear and level ground space, 28"-34" table height with knee and toe clearance.
 - City of Sonoma will provide the traffic safety devices that will designate your space per CA Vehicle Code, changing the use from a roadway to an extension of the sidewalk.

Per California Vehicle Code, the combination of traffic safety devices installed by the City and parklet exterior treatments installed by the business owner will delineate the parklet for pedestrian travel and set it apart from the roadway.



Fig.1 - EXAMPLE OF WHEEL STOP



Fig. 2 - EXAMPLE OF WATERWALL

SIGHT LINE ELEMENTS AND REQUIREMENTS

- The parklet design must ensure visibility to passing traffic and pedestrians and not create a visual barrier.
- The parklet shall maintain a visual connection to the street.
- A minimum overhead clearance of 96 inches must be provided for any parklet that includes a canopy (or similar element) in order to avoid creating a visual barrier and to provide adequate clearance for people.
- The parklet should have a notable, defined edge along the side of the parklet facing the roadway and adjacent parking stalls. This can be accomplished via a continuous railing, planter, fence, or similar structure.
- The height of the outside wall is dependent on the context but should be between 30 inches minimum on the street side to a maximum of 42 inches. You are allowed to include columns and other vertical elements.
- A raised platform may be installed. It must be accessible at several locations by pedestrians.
- Below are the measurement requirements for parklets located in parallel and diagonal spaces.
 - Parallel Parklets can not exceed 7 feet depth from the curb.
 - Diagonal Parklets range between 13-14 feet in depth from the curb
 - Sidewalk Extension needs to be a minimum of 48 inches in depth from the curb and needs to be a raised platform in order to be ADA compliant.



EXTERIOR PERIMETER TREATMENTS

- If you are using the parking lane for seating, retail, or other business activity, you must install barricades between the parking area and the traffic lane or any active parking. It is important to note intersections and corners have specific site line restrictions and will need to be evaluated by City staff.
- Your street side barricades must be:
 - ❑ 30 inches to 42 inches high (with openings of no more than 6 inches high) to protect, the purpose is to keep children from entering the roadway. Railings must have a solid bottom and top rail consisting of hog wire, or wood, and a minimum of 1 inch thick, cable or flexible rail in between. Due to the brittle nature of lattice it can not be used in the construction of the perimeter railing.
 - ❑ Not easily moved, altered or stolen.
 - ❑ If you are not using a platform than you are required to have stable and sturdy items placed no more than 6-8 feet apart along the roadside perimeter. Each stabilization item needs to weigh a minimum of 250 lbs, enough not to fall over or be pushed over (when leaned against). Viable options when weighted with gravel or sand galvanized planter boxes, wine barrels, galvanized stock ponds, and wood planter boxes.
 - ❑ Must be tied or connected together.
 - ❑ Do not include any lighting that is blinding to passing traffic.
 - ❑ Avoid providing a ledge for people to sit on.



BUILDING STANDARDS

To assist businesses the following standard plans have been created. The purpose of the standard plans is to provide a pre-approved standard design for construction.

Plan SP-01 – City of Sonoma Standard Plan for Temporary Raised Sidewalk Extension – Parallel Parking Space

Plan SP-02 – City of Sonoma Standard Plan for Temporary Raised Sidewalk Extension / Parklet - Diagonal Parking Space

Plan SP-03 – City of Sonoma Standard Plan for Temporary Raised Sidewalk Extensions – Section & Detail

Plan SP-04 – City of Sonoma Standard Plan for Street Parklet (no platform) - Diagonal Parking Space

Plan SP-05 – City of Sonoma Standard Plan for Temporary Raised Parklet - Diagonal Parking Space

Plan SP-06 - City of Sonoma Standard Plan for Temporary Raised Parklets with String Lights

Plan SP-08 - City of Sonoma Standard Plan for Temporary Raised Parklets – Elevation & Detail

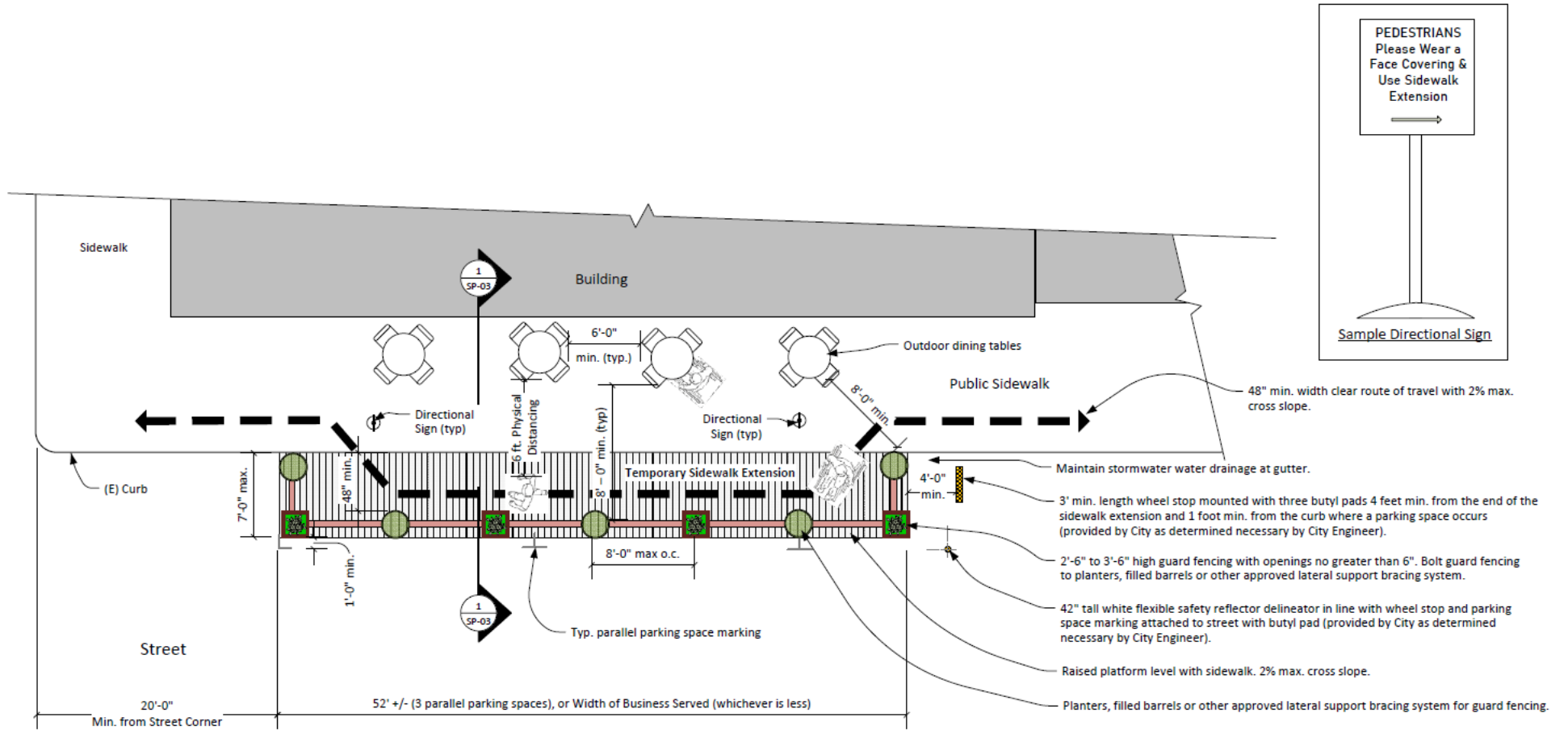

Print on 17" x 11" sized paper

City of Sonoma Standard Plan for Temporary Sidewalk Extensions at Parallel Parking Spaces

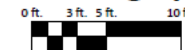

SP-01

REV 9/30/20

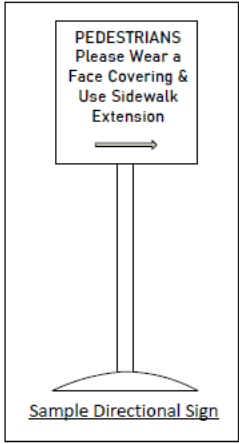
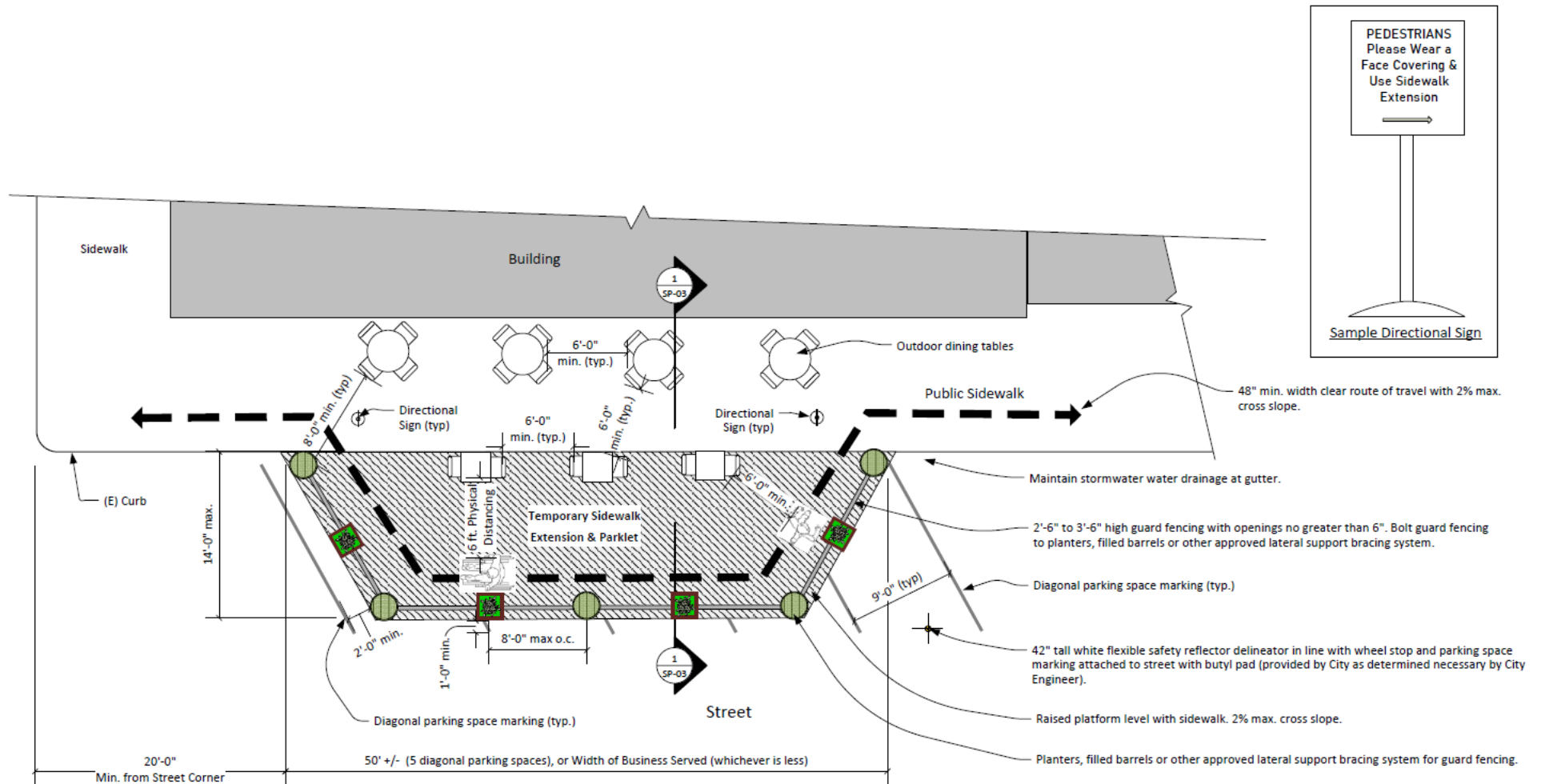

Notes:	
•	Sidewalk extensions shall not be located in front of red painted curbs, fire hydrants, fire department connections or within 20 feet of a street corner.
•	At least 5% and not less than one dining seating space shall be made accessible to disabled individuals (e.g. 30" x 48" min. clear and level ground space, 28" – 34" table height with knee and toe clearance, etc.)
•	Any modifications from the standards herein must be approved by the City Engineer and the Community Development Director.

City of Sonoma Standard Plan for Temporary Sidewalk Extension/Parklet at Diagonal Parking Spaces

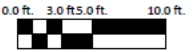

SP-02
REV 9/30/20

Print on 17" x 11" sized paper

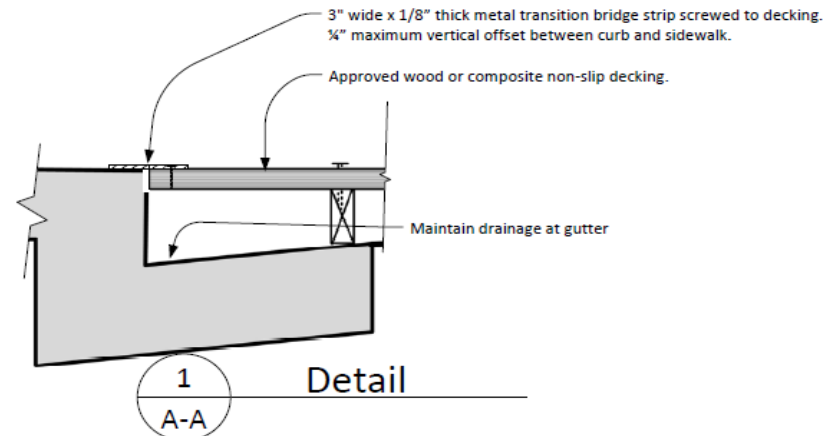
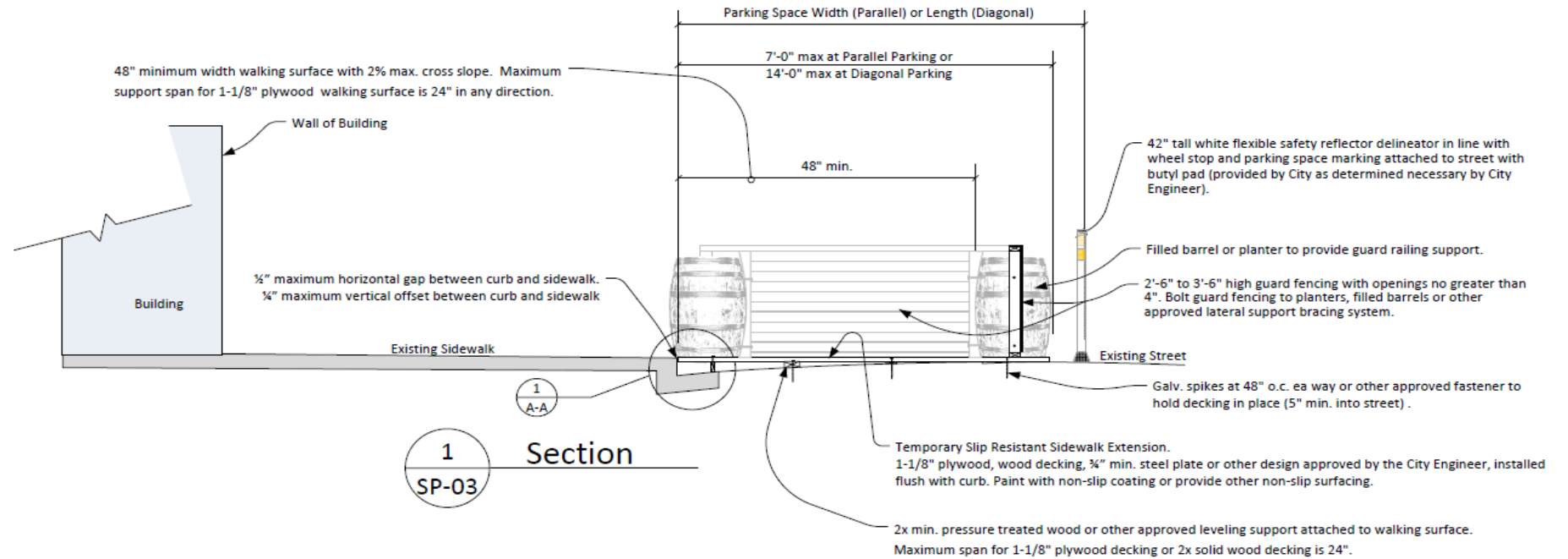

Print on 17" x 11" sized paper

City of Sonoma
Standard Plan for
**Temporary Sidewalk
Extensions**

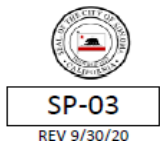

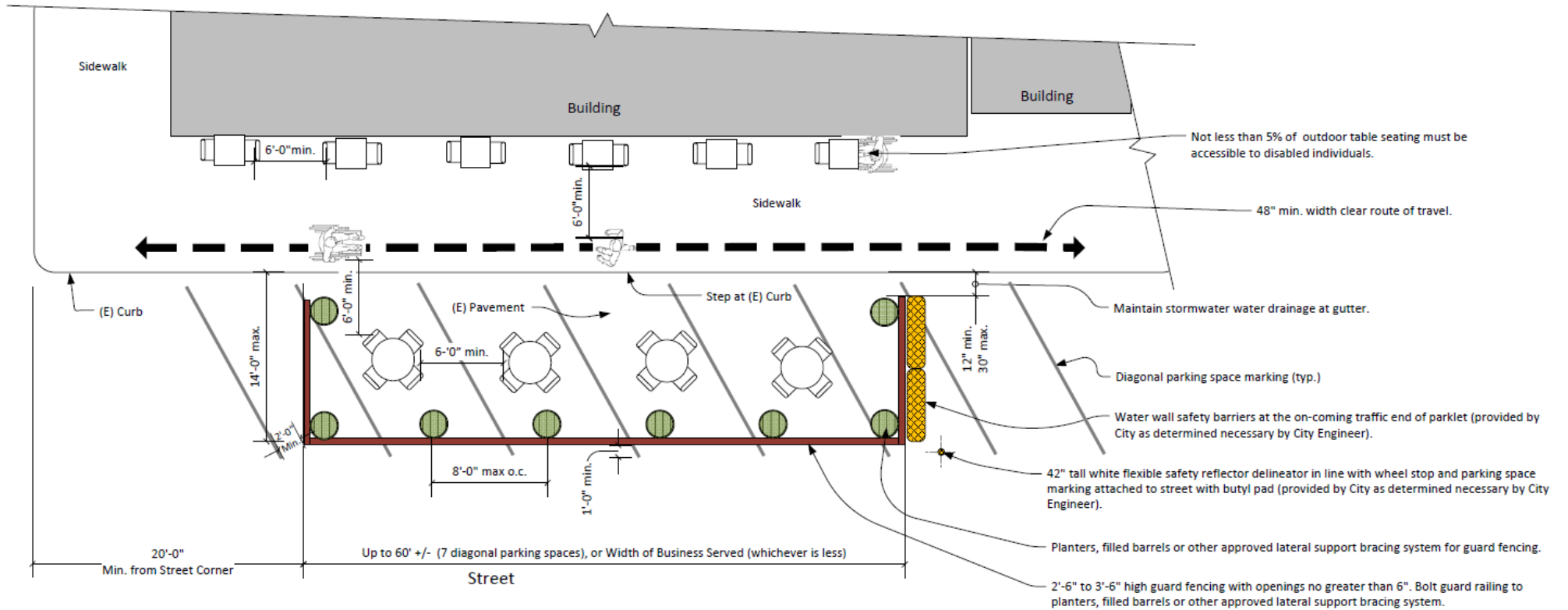

- Notes:**
- Parklets shall not be located in front of red painted curbs, fire hydrants, fire department connections or within 20 feet of a street corner.
 - At least 5% and not less than one dining seating space shall be made accessible to disabled individuals (e.g. 30" x 48" min. clear and level ground space, 28" – 34" table height with knee and toe clearance, etc.)
 - Any modifications from the standards herein must be approved by the City Engineer and the City Planning & Community Development Director.

Print on 17" x 11" sized paper

City of Sonoma Standard Plan for Street Parklet (no platform) at Diagonal Parking

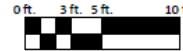

SP-04

REV 9/30/20

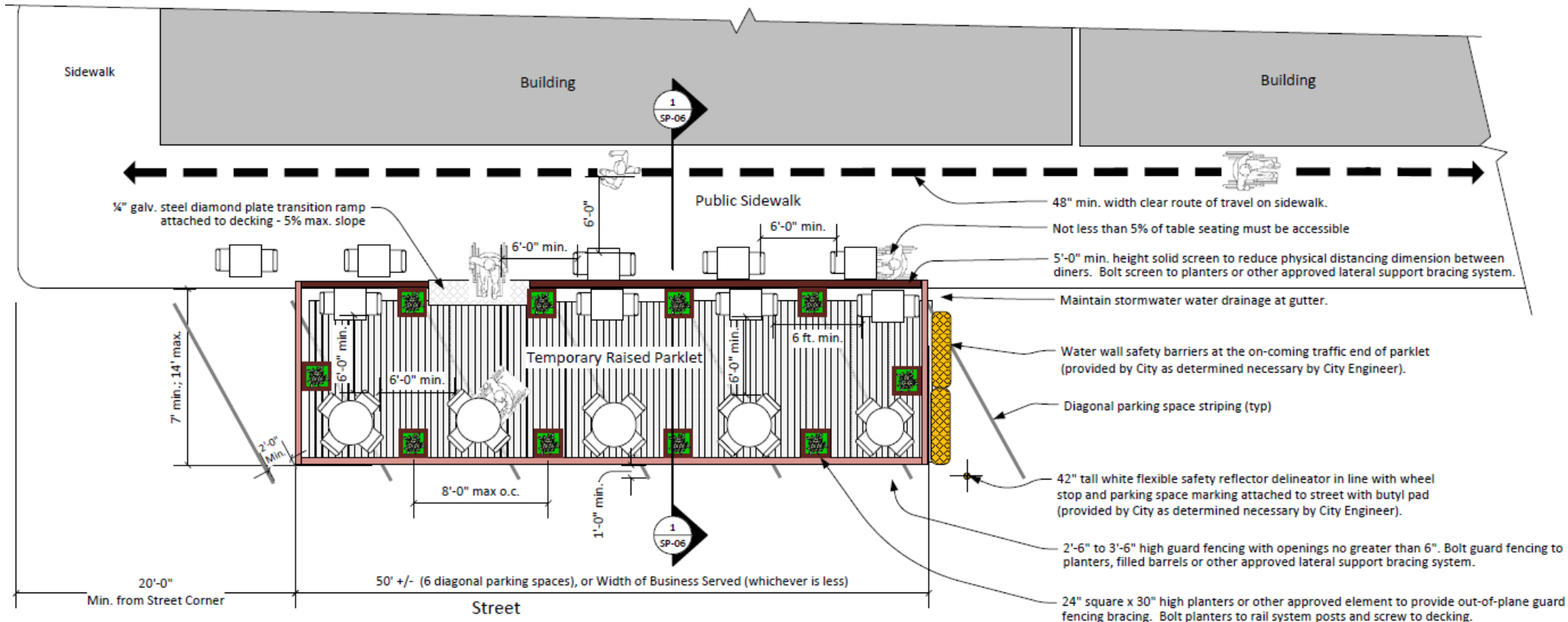

¼" galv. steel diamond plate transition ramp attached to decking - 5% max. slope

Public Sidewalk

48" min. width clear route of travel on sidewalk.

Not less than 5% of table seating must be accessible

5'-0" min. height solid screen to reduce physical distancing dimension between diners. Bolt screen to planters or other approved lateral support bracing system.

Maintain stormwater water drainage at gutter.

Water wall safety barriers at the on-coming traffic end of parklet (provided by City as determined necessary by City Engineer).

Diagonal parking space striping (typ)

42" tall white flexible safety reflector delineator in line with wheel stop and parking space marking attached to street with butyl pad (provided by City as determined necessary by City Engineer).

2'-6" to 3'-6" high guard fencing with openings no greater than 6". Bolt guard fencing to planters, filled barrels or other approved lateral support bracing system.

24" square x 30" high planters or other approved element to provide out-of-plane guard fencing bracing. Bolt planters to rail system posts and screw to decking.

Notes:

- Parklets shall not be located in front of red painted curbs, fire hydrants, fire department connections or within 20 feet of a street corner.
- At least 5% and not less than one dining seating space shall be made accessible to disabled individuals (e.g. 30" x 48" min. clear and level ground space, 28" – 34" table height with knee and toe clearance, etc.)
- Any modifications from the standards herein must be approved by the City Engineer and the City Planning & Community Development Director.

City of Sonoma Standard Plan for Temporary Raised Parklet at Diagonal Parking Spaces

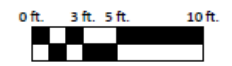

SP-05
REV 9/3020

Print on 17" x 11" sized paper

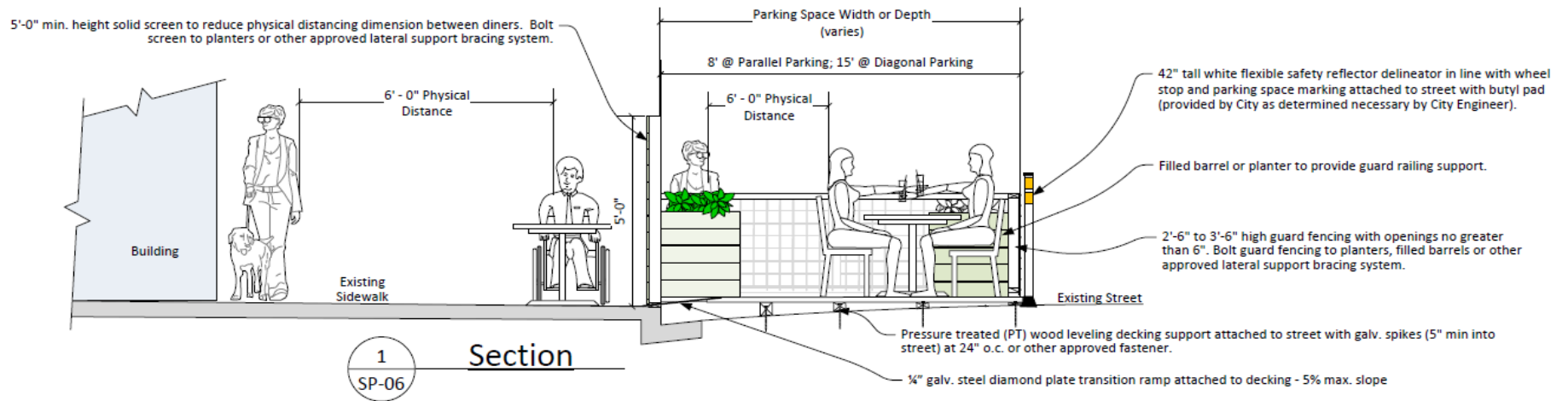

1 Section
SP-06

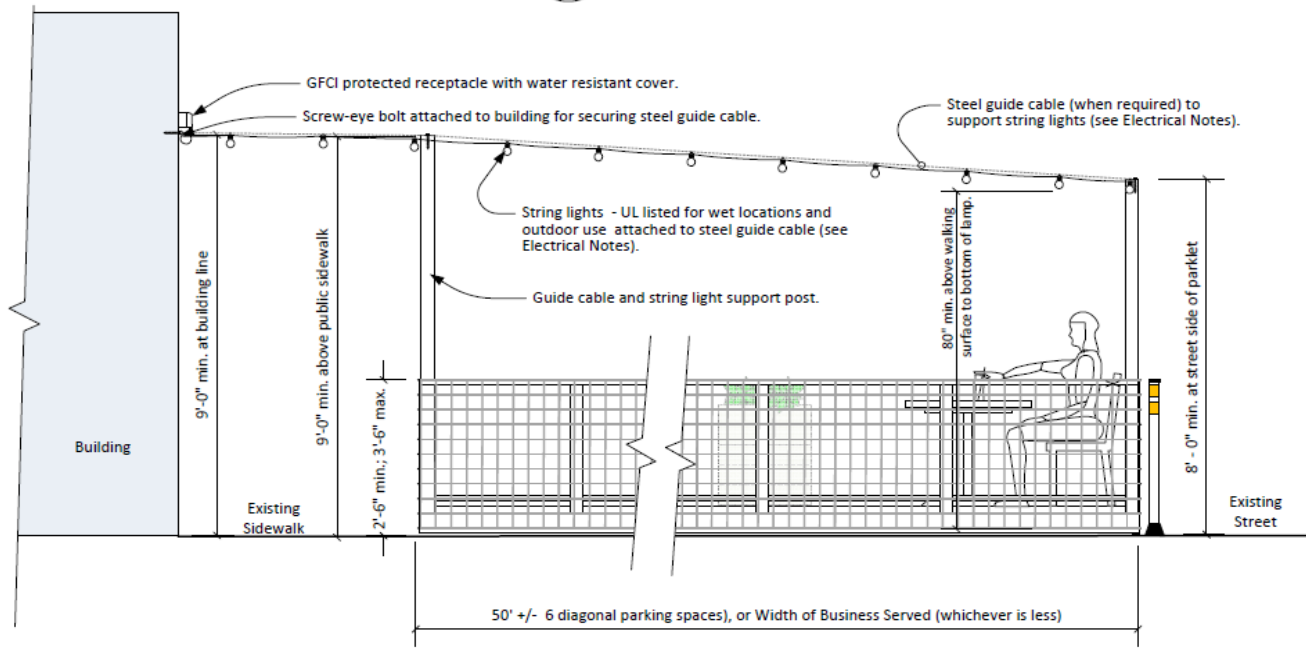

2 Street Elevation – Raised Parklet with String Lights
SP-06

Electrical Notes	
•	String lights may be installed for a period not to exceed of 90 days. Remove and inspect wire and lamp sockets for degradation due to weather, UV light or other damage prior every 90 days and prior to any re-installation.
•	Ground Fault Circuit Interrupter protection (GFCI) is required on the circuits or outlets serving the string lights. A receptacle cover must be in place to prevent the entry of water.
•	String lights must comply with UL Standard 588 and be listed for use in outdoor and wet locations.
•	String lights must be LED luminaires and controlled by an astronomical time clock <u>or</u> by a photo cell and a time clock.
•	String lights must be capable of being turned off by a readily accessible switch or remote control.
•	String lights must be installed in accordance with the owner installation manual, and the current California Electric Code.
•	String lights must be supported by steel guide cables, with zip ties and eyebolts, or other suitable supporting hardware whenever span distances exceed 10 feet unless longer spans are specified in the manufacturer's installation instructions.
•	If an extension cord is used, it must be rated for outdoor use. Use only three wire outdoor extension cords that have three-prong grounding plugs and grounding receptacles that accept the three prong plug.
•	Keep combustible material clear of bulbs. Do NOT allow lamps or sockets to come into contact with walls, fabrics, canopies, umbrellas or other combustible materials.
•	String lights and extension cords shall not be secured with staples and shall not run through windows, door openings or other openings through walls.

City of Sonoma
Standard Plan for Temporary
Raised Parklets with String Lights



SP-06

REV 9/30/20

Print on 17" x 11" sized paper

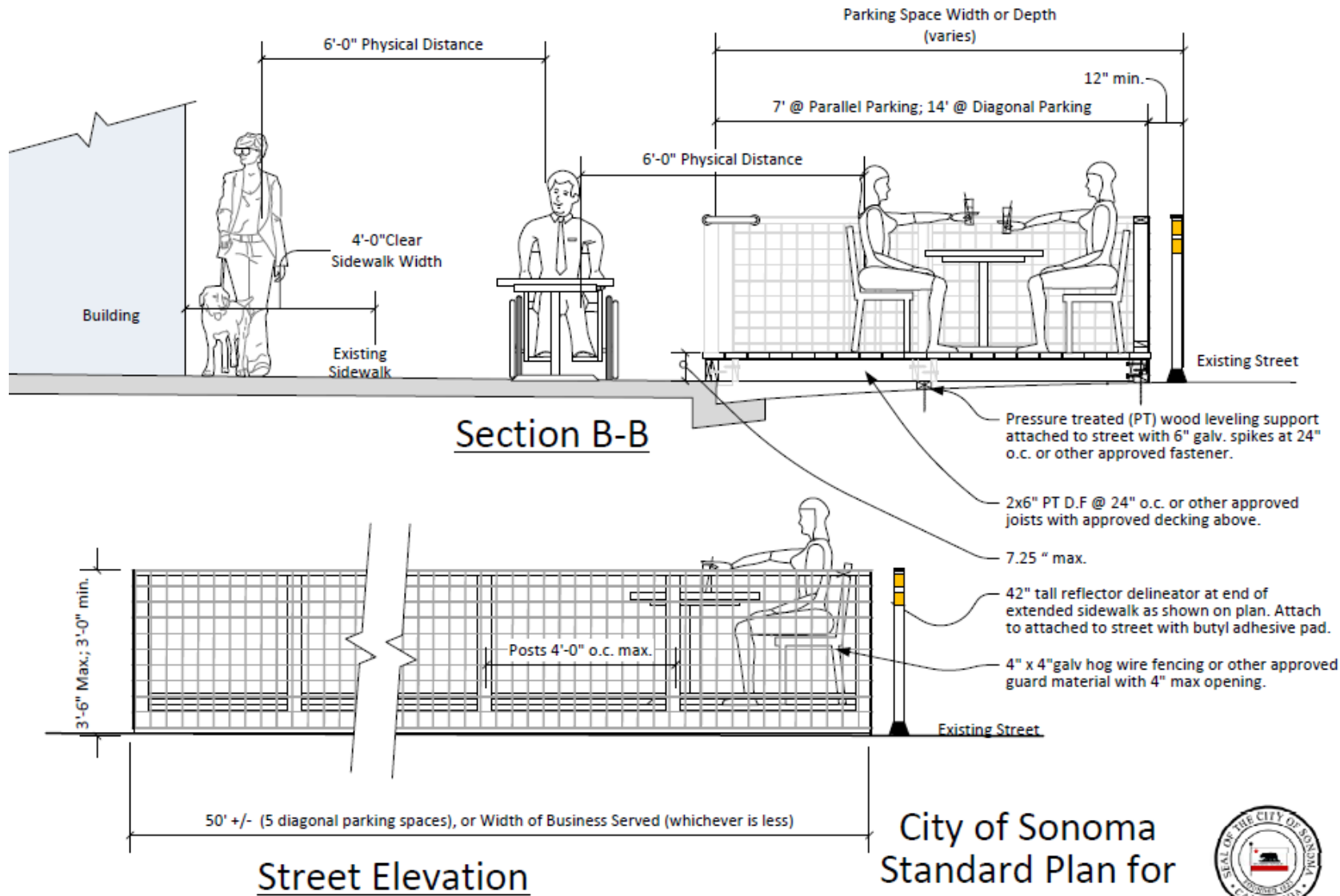

City of Sonoma
Standard Plan for
Temporary Raised
Parklet



SP-08
REV 9/21/20

REV 9/21/20

AMENITIES GENERAL

Seating -- All parklets must incorporate seating, which can be integrated in a variety of creative ways. These seats can be a part of the structure, planters, or creative features within the parklet. Seating and tables can also be movable as well. This seating can be removed and stored at the end of the day or locked with cables to the parklet structure.

Landscaping -- Parklets are highly encouraged to have some type of landscaping. Landscape plantings help soften the space and can serve as a pleasant buffer along the street-facing edge. Landscape elements may be incorporated as planter boxes, hanging planters, green walls, raised beds, or similar features. Drought-tolerant and native plants are good choices for ease of maintenance. Edible plants and plants with fragrance, texture, and seasonal interest are also recommended.

Signs -- Additional signage to clarify the affinity of the space with the adjacent business will be allowed. Any temporary signage will be reviewed and approved by Planning staff.

Canopy -- The City considers a canopy an overhead roof with no more than one side. A canopy may be made of tent like materials or may be more hardened out of wood or metal. Currently, the Public Health Orders appear to allow a canopy and not a tent (4 sides). Additional requirements on canopies may be developed by Sonoma County or the State. A canopy may require a separate review from the Fire Department.

Barriers Between Tables -- The County currently allows businesses to install solid material screens/barriers (plexi or wood) between tables eliminating the requirement of 6' of physical distance between diners. These screens need to extend up to 5 feet high.

Heating -- Portable outdoor gas-fired heating appliances can help to make the parklet more comfortable throughout the year. They are allowed in open air parklets with location restrictions and will need to comply with CA State Fire Codes – Fire Department Rules and Regulations <https://svfra.org/reopening-post-covid-19.html> ** Parklet that require a tent permit from the fire department or a building permit from the City Building Department will not be allowed to use portable outdoor gas-fired heating appliances.

Lighting -- Lighting is allowed. Self-contained low-voltage systems, such as solar or battery-powered lights, are a good choice. See Standard Plan sheet SP-06 for string light installations. Business owner will be responsible for cabling of guide wires to mitigate tripping hazards.



SEATING DIAGRAMS

All parklets must incorporate seating, which can be integrated in a variety of creative ways, below are a few examples of ways to integrate seating into a 14' x 50' space and a 7' x 50' space. It is important to ensure all seating has a 6 feet of distance between patrons or a 5 feet high screens/ barrier separating the tables for public safety.

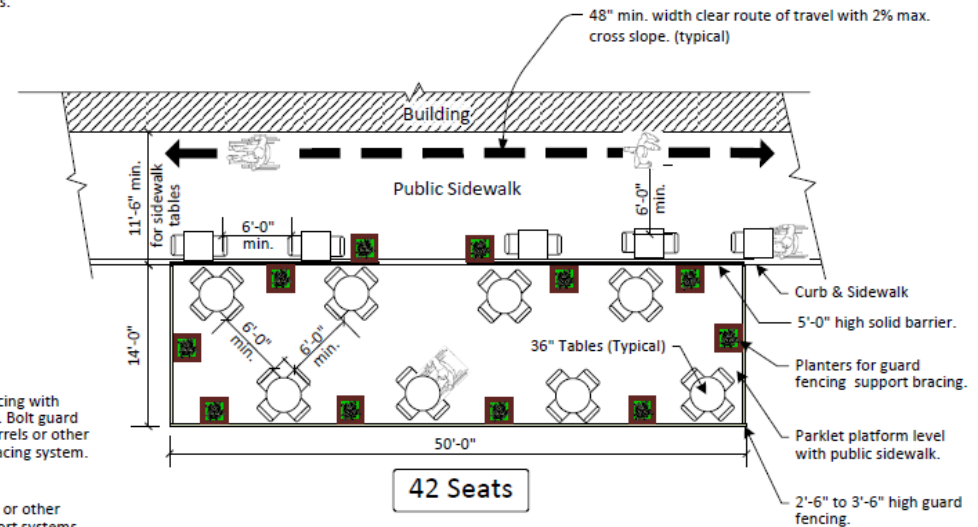
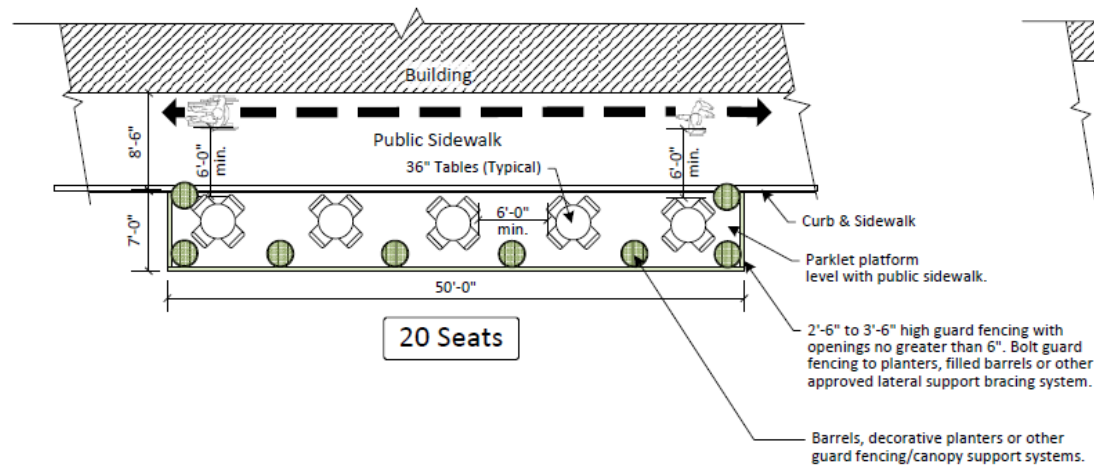
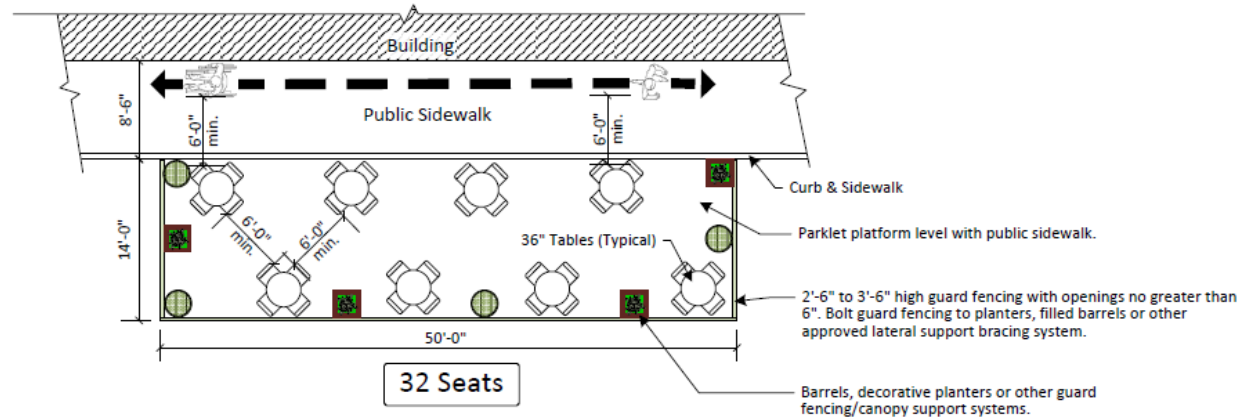

CANOPIES

Public Health Order appears to allow for a canopy with one wall to be utilized for outdoor seating. Additional Public Health requirements on canopies may be communicated by Sonoma County or the State. However per the Fire Marshal outdoor heaters potentially can only be used near a canopy if they do not require a permit and the heater manufactures installation instructions are followed (clearance from combustibles) coverings must also meet flame resistance requirements of CA Title 19.

- For canopies less than 700 sq. ft., the Fire Department doesn't require a tent permit.
- The semi-permanent canopy structures should be designed to resist the wind loads of Chapter 16 of the CA Building Code.
- Canopies can be secured to free standing concrete bases or water filled bases. Avoid installations that require drilling into the street/sidewalk this would entail additional conditions and a longer approval process.
- Canopies should be white or cream in color, if you prefer a different color, the Planning Department will need to approve.

Fire Department Rules:

Please note you cannot erect a tent with sides, so it automatically pushes you to a canopy which falls under the exceptions highlighted below.

APPROVAL / PERMIT REQUIRED

3103.2 Approval required. Tents (with walls) and membrane structures having an area in excess of 400 square feet (37 m²) shall not be erected, operated or maintained for any purpose without first obtaining a permit and approval from the fire code official.

Exceptions:

1. Tents used exclusively for recreational camping purposes.
2. **Tents open on all sides (canopy) that comply with all of the following:**
 - 2.1. Individual tents having a maximum size of 700 square feet (65 m²).
 - 2.2. The aggregate area of multiple canopies placed side by side without a fire break clearance of 12 feet (3658 mm), not exceeding 700 square feet (65 m²) total.
 - 2.3. A minimum clearance of 12 feet (3658 mm) to all structures and other tents/canopies.

If the temporary membrane structure does not meet the above exceptions than it is regulated by Chapter 31 of the Fire Code.



CANOPIES – LARGER THAN 700 SF OR WALL

For Canopies larger than 700 sq. ft. or those that are smaller but have one wall.

Will need to comply with California Building Code Chapter 31 regulations (see below)

3103.8.2 Location [California Code of Regulations, Title 19, Division 1, §312] Parking of Vehicles.

Vehicles necessary to the operation of the establishment, shall be parked at least 20 feet from any tent. No other vehicle shall be parked less than 100 feet from any tent except vehicles parked on a public street shall park at least 20 feet from any tent.

3103.12.6 Exit Signs

3103.12.6.1 Exit Sign Illumination



HEATING

If the parklet is not regulated and meets the exceptions listed on page 16 highlighted in red, heaters can be used that were listed and labeled and clearance from combustibles was in accordance with the manufacturer's recommendations.

In parklets not regulated as a tent propane container location would have to comply with 2019 CFC Table 6104.3 (please see chart to side)

Avoid utilizing a canopy that has any walls, even one side wall will ensure adherence to Chapter 3 Fire Rules and Regulations and could prohibit your ability to utilize heaters.

For specific questions regarding the use of heaters please contact the Sonoma Valley Fire District:

Trevor Smith, Fire Marshal
TrevorS@Ssvfra.org
 707-933-2305 (office)

6104.3 Container Location

LP-gas containers shall be located with respect to buildings and lot lines of adjoining property that can be built upon, in accordance with Table 6104.3.

TABLE 6104.3

LOCATION OF LP-GAS CONTAINERS			
LP-GAS CONTAINER CAPACITY (water gallons)	MINIMUM SEPARATION BETWEEN LP-GAS CONTAINERS AND BUILDINGS, PUBLIC WAYS ^b OR LOT LINES OF ADJOINING PROPERTY THAT CAN BE BUILT UPON		MINIMUM SEPARATION BETWEEN LP-GAS CONTAINERS ^{b, c} (feet)
	Mounded or underground LP-gas containers ^a (feet)	Above-ground LP-gas containers ^b (feet)	
Less than 125 ^{c, d}	10	5 ^e	None

LIGHTING

Lights can be a wonderful way to create ambiance within the parklet. Lights can be installed within the parklet and over the sidewalk by incorporating a post element into your parklet design railing treatment.

Due to Sonoma's historic downtown buildings, some sites will require more creative solutions to not damage historic structures.

Please include a lighting plan with your parklet paperwork. It needs to include specific locations of anchor points, type of wall anchors proposed for install, size of lateral cabling, and where the electricity is being drawn from (interior of building or exterior of building).

Additional detailing would be needed for the proposed construction of the overhead lighting support system to show how lateral bracing is provided.

All lighting must meet electrical code and energy code requirements. All lighting types, lighting controls and the routing of the electrical needs to be clearly indicated on an electrical plan.

Running electrical cords along or on the public sidewalk is prohibited.

See Standard Plan SP-06 for basic requirements for string lights. String light installations meeting the requirements of Standard Plan SP-06 will not require a building permit for installation.



IN APPRECIATION

The City would like to thank the following vendors listed on this page. These organizations have helped the City to identify costs, designs concepts, and provided subject matter expertise to develop many of the parameters included in these City guidelines.

Sonoma Vendors

GMH Builders

901 Broadway
Sonoma, CA 95476
www.gmhbuild.com
[\(707\) 757-5050](tel:(707)757-5050)

Ron Wellander, Landscape Architect

294 W Napa St
Sonoma, CA 95476
[\(707\) 480-2748](tel:(707)480-2748)

Vendors From Outside the Area

TOP PRODUCTION

Sausalito, CA
PO Box 1112
Sausalito, CA 94966
<https://www.top-productions.com/>
415.332.3005

VCG GLOBAL

Rocklin, CA
5961 W. Oaks Blvd, Suite A
Rocklin, CA 95765
<https://www.vcgglobal.com/>
(888) 327-7700

How to Proceed:

Email or call Associate Planner, Wendy Atkins WAtkins@Sonomacity.org or 707.933,2204. She is available to assist with providing clarification of the guidelines, the process and development of the site plan. Once you have a site plan, you'll be assigned a designated project manager who will work with you on the submission of the following documentation for the encroachment permit and guide you through the process.

Required Documentation – Plan Submission

Submit a site plan (this can be hand drawn), the site plan should include:

- Specific dimensions of the parklet in relation to your business (width of sidewalk in front of building);
- Indicate if your plan is to build a platform or if it is a step down to the street level;
- Location of Fire Suppression connections on the building or on the sidewalk.
- Detailed construction drawings of any proposed structure for a parklet or sidewalk extension that does not meet the requirements of the City's Standard Plans (e.g. SP-01 through SP-06).
- If you meet the ADA accessibility requirements and plan to have a step down parklet the plans need to include the perimeter railings with weighted structures.
- Indicate if you are planning on utilizing both the parklet dining and the sidewalk for dining and if so how you plan to accommodate pedestrian traffic.
- Placement of the railings with a description of type of materials used to make the railings, heights of railings and placement within the parklet.
- Location of canopies (include dimensions, location of tie downs, and proximity to building and roadway).
- Detailed electrical plan (if electrical work is proposed).
- Seating plan demonstrating public health safety requirements of 6' of physical distance between diners and 6' of physical distance between persons for pedestrian pathways.
- Description of the ADA accessibility. If your plan is to have a step down parklet than you must have an ADA accessible option on the sidewalk.

Complete the Parklet Encroachment permit, sign the Terms and Conditions for a Temporary Parklet and submit the required insurance documentations as outlined on page 26 of this document. If you are working with a contractor to build your parklet or a portion of your parklet, they will also need to complete an encroachment permit and submit insurance covering the construction period of the parklet. The City of Sonoma has received authorization to waive all encroachment permit fees and inspection fees as they pertain to Business Reopening plans.

Your insurance documentation will need to include the specific description of use. i.e. Outdoor facility expansion to encroach into the public right-of-way in front of (insert your address) for outdoor dining service. Please forward the attached insurance document to your insurance provider so the language on the endorsements is correct and the minimum coverages are met.

PARKLET PROCESS



Meet with City to determine size, scope and parameters	Create site plan (City staff can assist)	If raised platform	Required Documentation Site Plan
Each site is unique and may require special treatments.	Review ADA access	Determine if building to the City of Sonoma building standards	Outline ADA plan
Identify Fire Safety suppression hook ups (on building or hydrants)	Decide if you are moving forward with a raised platform or step down to curb level	If taking a different approach submit architectural building plans include elevations, curb/drainage treatments	Complete Encroachment Permit
Identify location of parklet	Identify all amenities within the parklet (canopies, heaters, lighting etc.)	Building Permit becomes a requirement for all platform builds.	Sign the Terms and Conditions
Review the seating charts to gauge occupancy maximums			Meet the Insurance Minimums

Contact List

Wendy Atkins, Associate Planner, City of Sonoma

WAtkins@Sonomacity.org

Phone 707-933-2204

Mark Bodenhamer, CEO, Sonoma Valley Chamber of Commerce

Mark@sonomachamber.org

Phone 707-996-1033

Wayne Wirick, Development Services Director/Building Official, City of Sonoma

WWirick@sonomacity.org

Phone 707-933-2211

Lisa Janson, Special Events/Projects, City of Sonoma

Ljanson@sonomacity.org

Phone 415-259-9458

Trevor Smith, Fire Marshal, Sonoma Valley Fire District

TrevorS@svfra.org

Phone 707-933-2305