

# FUELING STATION IMPROVEMENT PROJECT

| SHEET INDEX            |   |
|------------------------|---|
| Sheet Number           | SHEET TITLE                               |
| GENERAL                |   |
| G0.01                  | COVER SHEET                               |
| G0.02                  | ABBREVIATIONS AND LEGEND                  |
| G0.03                  | NOTES                                     |
| EXISTING CONDITIONS    |   |
| C1.10                  | EXISTING CONDITIONS                       |
| C1.11                  | DEMO PLAN                                 |
| C1.20                  | PROPOSED CONDITIONS                       |
| PAVING AND STORM SEWER |   |
| C6.01                  | PAVING AND STORM DETAILS                  |
| ME0.01                 | COVER SHEET                               |
| MED1.10                | MECHANICAL AND ELECTRICAL DEMOLITION PLAN |
| ME1.20                 | MECHANICAL AND ELECTRICAL PLAN            |
| ME2.10                 | MECHANICAL AND ELECTRICAL DETAILS         |
| ME3.10                 | MECHANICAL AND ELECTRICAL SCHEDULES       |
| E2.20                  | CANOPY LIGHTING PLAN                      |

| Rev                         | Description          | Date                     |
|-----------------------------|----------------------|--------------------------|
| 2/4/2025                    | Project Number 24132 | 2/4/2025                 |
| 2/4/2025 8:16 AM ANGE MAREK | Project Manager LNR  | Issued For Construction: |

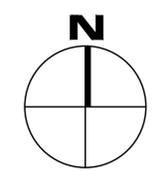

PROJECT LOCATION

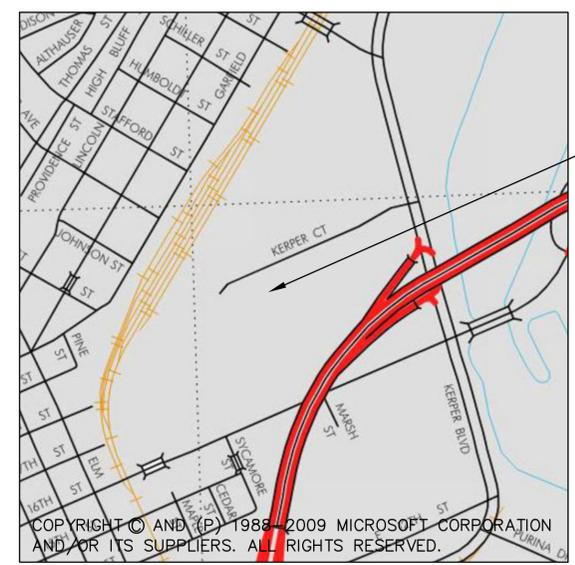

PROJECT SITE

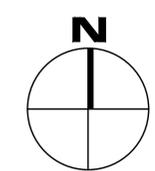

PROJECT SITE

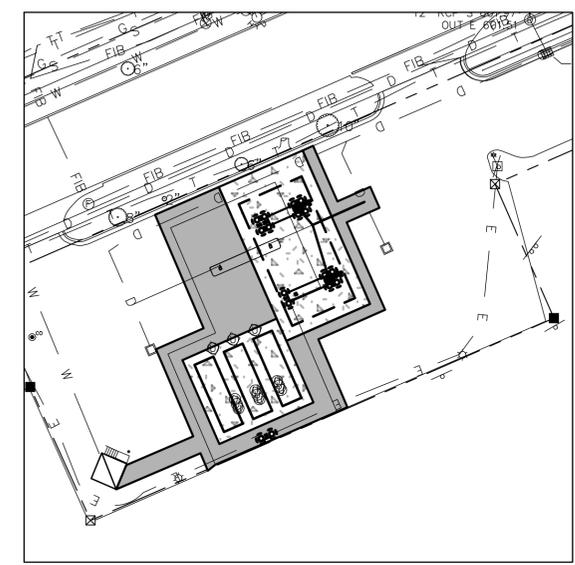

## PROJECT INFORMATION

|  |  |
|--|--|
| <b>LEGAL DESCRIPTION:</b><br>LOT 2-2 KERPER INDUSTRIAL PARK                  | <b>UTILITY NOTE:</b><br>THE LOCATIONS OF THE EXISTING UTILITIES SHOWN ARE APPROXIMATE ONLY. THE UTILITIES PRESENT MAY NOT EXIST AS SHOWN. ADDITIONAL FACILITIES OTHER THAN THOSE SHOWN MAY BE PRESENT. IT SHALL BE THE RESPONSIBILITY OF ANYONE USING THIS DOCUMENT TO ASCERTAIN THE EXACT LOCATION, SIZE, TYPE, MATERIAL, AND ELEVATION OF ALL UTILITIES THAT MAY BE PRESENT. |
| <b>PROPERTY ADDRESS:</b><br>925 KERPER CT                                    |  |
| <b>PROPERTY OWNER:</b><br>CITY OF DUBUQUE<br>50 W 13TH ST. DUBUQUE, IA 52001 |  |
| <b>BUILDING HEIGHT:</b><br>N/A   |  |
| <b>IMPERVIOUS AREA:</b><br>1.09  |  |
| <b>TOTAL AREA:</b><br>1.48   |  |
| <b>ZONING CLASSIFICATION:</b><br>MHI   |  |
| <b>GOVERNING AUTHORITY:</b><br>CITY OF DUBUQUE                               |  |
| <b>UTILITY PROVIDERS:</b>  |  |
| <b>SEWER:</b>  | CITY OF DUBUQUE<br>GUS PSIHUYOS<br>(563) 589-4270<br>gpsihoyo@cityofdubuque.org  |
| <b>GAS:</b>  | BLACK HILLS ENERGY DUBUQUE<br>JUSTIN LEHMAN<br>(563) 585-4011<br>justin.lehman@blackhillscorp.com  |
| <b>ELECTRICAL POWER:</b>   | ALLIANT ENERGY<br>(800) 255-4268<br>locate_PL@alliantenergy.com  |
| <b>TELECOMMUNICATIONS:</b>   | CENTURYLINK<br>SADIE HULL<br>(918) 547-0147<br>sadie.hull@lumen.com  |
|  | MEDIACOM<br>CHRIS MINARD<br>(815) 597-5103<br>cminard@mediacomcc.com   |
|  | IMON COMMUNICATIONS, LLC<br>ENGINEERING GROUP<br>(319) 200-7740<br>imonengineering@imon.net  |
| <b>WATER:</b>  | CITY OF DUBUQUE WATER DIVISION<br>CHRISTOPHER LESTER<br>(563) 589-4291<br>clester@cityofdubuque.org  |

## PROFESSIONAL SEALS

I hereby certify that this engineering document was prepared by me or under my direct personal supervision and that I am a duly licensed Professional Engineer under the laws of the State of Iowa. My license renewal date is December 31, 2026.

 *Michael J. Brocka* 2/4/2025 Date  
Michael J. Brocka Date

Pages or sheets covered by this seal:  
Specification Div.: 26  
Drawings: ALL "ME" AND "E" SHEETS IN INDEX

## CONTACT

**PROJECT MANAGER**  
MIKE BROCKA  
MBROCKA@MODUS-ENG.COM

**MECHANICAL ENGINEER**  
ANDREW NEWLON  
ANEWLON@MODUS-ENG.COM

**ELECTRICAL ENGINEER**  
DAVID JORDAN  
DJORDAN@MODUS-ENG.COM

CODY T. AUSTIN, PE, LEED AP  
ORIGIN DESIGN CO.  
137 MAIN ST, SUITE 100  
DUBUQUE, IA 52001  
V. (563)556-2464  
F. (563)556-7811  
E. cody.austin@origindesign.com



I HEREBY CERTIFY THAT THIS ENGINEERING DOCUMENT WAS PREPARED BY ME OR UNDER MY DIRECT PERSONAL SUPERVISION AND THAT I AM A DULY LICENSED PROFESSIONAL ENGINEER UNDER THE LAWS OF THE STATE OF IOWA

FOR ORIGIN DESIGN CO.  
*Cody T. Austin* 2/4/2025 DATE  
CODY T. AUSTIN DATE

PE 19027 12/31/2025 RENEWAL DATE  
LICENSE #  
ALL SHEETS IN SHEET SET  
PAGES OR SHEETS COVERED BY THIS CERTIFICATION:  
ALL "G" AND "C" SHEETS IN INDEX



ALL CONSTRUCTION SHALL BE PER APPLICABLE SECTIONS OF THE 2023 EDITION OF SUDAS STANDARD SPECIFICATIONS, 2023 EDITION OF CITY OF DUBUQUE SUPPLEMENTAL SPECIFICATIONS, AND STANDARD PLANS FOR PRODUCTS AND EXECUTION EXCEPT AS MODIFIED OR SUPERCEDED BY THESE PLANS. REMOVE SECTIONS 1.08 FROM EACH DIVISION AND FOLLOW PAYMENT INFORMATION WITHIN SECTION 00401.

## SITE RELATED QUANTITIES

| THE CITY OF<br><b>DUBUQUE</b><br><i>Masterpiece on the Mississippi</i> |                  | City of Dubuque, Iowa<br>Special Provisions  |               |      | Addendum No.:                      | N/A |
|--|------------------|--|---------------|------|------------------------------------|-----|
| Project Title:   |                  | City of Dubuque Fueling Station Improvement Project  |               |      |                                    |     |
| LINE NO.   | REFERENCE NUMBER | BID ITEM DESCRIPTION   | PLAN QUANTITY | UNIT | REFERENCED SPECIFICATION           |     |
| <b>Division 2010 - Earthwork, Subgrade, and Subbase</b>                |                  |  |               |      |                                    |     |
| 1  | 2010-108-E-0     | Excavation, Class 10<br>See Site Plan sheets C1.20 for excavation locations.   | 1632.00       | CY   | Dubuque Supplemental Specification |     |
| 2  | 2010-108-G-0     | Subgrade Preparation<br>Subgrade preparation includes scarification and recompaction of subgrade to a minimum 6 inches below top of subgrade. Contractor is responsible for compaction testing per SUDAS Specifications. | 1011.00       | SY   | SUDAS Standard Specification       |     |
| 3  | 2010-108-J-0     | Subbase, Granular Subbase - Gr 12a (Granular Subbase Pile)   | 2212.00       | TON  | Dubuque Supplemental Specification |     |
| 4  | 2010-108-J-0     | 4" Subbase & Backfill for Fuel Tank Removal and Installation<br>Subbase, Modified Subbase - Gr 14 (Modified Subbase Pile)  | 205.00        | TON  | Dubuque Supplemental Specification |     |
| 5  | 2010-108-J-0     | PCC 4" Subbase (See Detail 2 C6.01) & HMA 4" Subbase (See Detail 3 C6.01)<br>Subbase, 3" Breaker Run, (Modified Macadam Pile)<br>PCC 6" Subbase (See Detail 2 C6.01) & HMA 8" Subbase (See Detail 3 C6.01)               | 345.00        | TON  | Dubuque Supplemental Specification |     |
| <b>Division 3010 - Trench Excavation and Backfill</b>                  |                  |  |               |      |                                    |     |
| 6  | 3010-108-K-0     | Trenching, 48 Inch Depth   | 36.00         | LF   | Dubuque Supplemental Specification |     |
| <b>Division 4020 - Storm Sewers</b>                                    |                  |  |               |      |                                    |     |
| 7  | 4020-108-D-0     | Removal of Storm Sewer   | 34.00         | LF   | Dubuque Supplemental Specification |     |
| 8  | 4020-108-E-2     | Concrete Collar Pipe Connection - Type PC-2  | 2.00          | EA   | Dubuque Supplemental Specification |     |
| <b>Division 7010 - Portland Cement Concrete Pavement</b>               |                  |  |               |      |                                    |     |
| 9  | 7010-108-A-0     | Pavement, PCC, 7" (Thickness)  | 526.00        | SY   | SUDAS Standard Specification       |     |
| <b>Division 7020 - Hot Mix Asphalt Pavement</b>                        |                  |  |               |      |                                    |     |
| 10   | 7020-108-A-0     | HMA Surface Layer Pavement by Ton<br>Bid item includes, but not limited to binder course.  | 54.00         | TON  | SUDAS Standard Specification       |     |
| 11   | 7020-108-A-0     | HMA Intermediate Layer Pavement by Ton   | 81.00         | TON  | SUDAS Standard Specification       |     |
| <b>Division 7040 - Pavement Rehabilitation</b>                         |                  |  |               |      |                                    |     |
| 12   | 7040-108-H-0     | Pavement - Removal   | 1011.00       | SY   | SUDAS Standard Specification       |     |
| <b>Division 9040 - Erosion and Sediment Control</b>                    |                  |  |               |      |                                    |     |
| 13   | 9040-108-T-1     | Inlet Protection Device, Installation<br>Bid item includes, but not limited to, removal of device upon completion of the project   | 3.00          | EA   | SUDAS Standard Specification       |     |
| 14   | 9040-108-T-2     | Inlet Protection Device, Maintenance   | 3.00          | EA   | SUDAS Standard Specification       |     |
| <b>Division 10,010 - Demolition of Building Structures</b>             |                  |  |               |      |                                    |     |
| 15   | 10010-108-A-0    | Demolition Work<br>Bid item includes, but not limited to, removal of fuel pump canopy, fuel pumps, underground fuel tanks.   | 1.00          | LS   | Dubuque Supplemental Specification |     |
| <b>Division 11,020 - Mobilization</b>                                  |                  |  |               |      |                                    |     |
| 16   | 11020-108-A-0    | Mobilization   | 1.00          | LS   | SUDAS Standard Specification       |     |
| <b>Division 11,050 - Concrete Washout</b>                              |                  |  |               |      |                                    |     |
| 17   | 11050-108-A-0    | Concrete Washout   | 1.00          | LS   | SUDAS Standard Specification       |     |
| <b>Special Provisions - Non-Standard Project Items</b>                 |                  |  |               |      |                                    |     |
| 18   | SP               | Bollard  | 16.00         | EA   | Non-Standard Project Specification |     |
| 19   | SP               | Pavement, PCC, 13" (Thickness)<br>Fuel Pump Islands  | 27.00         | SY   | Non-Standard Project Specification |     |



origindesign.com  
800 556-4491  
© Origin Design Co.

Client Name  
CITY OF DUBUQUE

Project Name  
FUELING STATION  
IMPROVEMENT  
PROJECT

Location / Description  
925 KERPER CT.  
DUBUQUE, IA

| Rev   | Description     | Date                        |
|-------|-----------------|-----------------------------|
| 24132 | Project Number  | 2/4/2025                    |
| LN    | Project Manager | Issued For Bidding:         |
| LN    | Project Manager | Issued For Construction:    |
| LN    | Project Manager | 2/4/2025 8:16 AM ANGE MAREK |

Sheet Title

NOTES

# G0.03

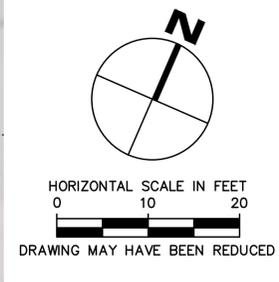

KERPER COURT

EX UTIL MH 60503  
RIM 610.11  
24" RCP N 601.90  
36" RCP W 601.89  
12" RCP S 601.97  
OUT E 601.51

EX G @ CB 60546  
RIM 608.89  
12" RCP W 602.04  
12" RCP N 602.19

EX COR GRATE LB 60583  
RIM 608.10  
12" RCP N 603.60

EX COR GRATE LB 60568  
RIM 608.20  
12" RCP S 603.02  
12" RCP N 602.93

- EXISTING KEYED NOTES**
- A. 3 BELOW GRADE FUEL TANKS
  - B. CANOPY FOOTING ISLAND AND PUMPS
  - C. PUMP CANOPY
  - D. WATER HOUSE
  - E. PCC PAVEMENT
  - F. STORM SEWER
  - G. WATER MAIN
  - H. SANITARY SEWER
  - I. GAS LINE
  - J. ELECTRIC
  - K. ELECTRICAL BOX
  - L. LIGHT POLE
  - M. FIBER OPTIC
  - N. UTILITY MANHOLES
  - O. TELECOMMUNICATION LINE
  - P. SIGN
  - Q. MANUAL COMPOST LOADING PILE

| Rev | Description          | Date   |
|-----|----------------------|--|
|     | Project Number 24132 | Issued For Bidding: 2/4/2025                         |
|     | Project Manager: LNR | Issued For Construction: 2/4/2025 8:16 AM ANGE MAREK |

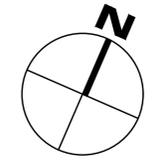
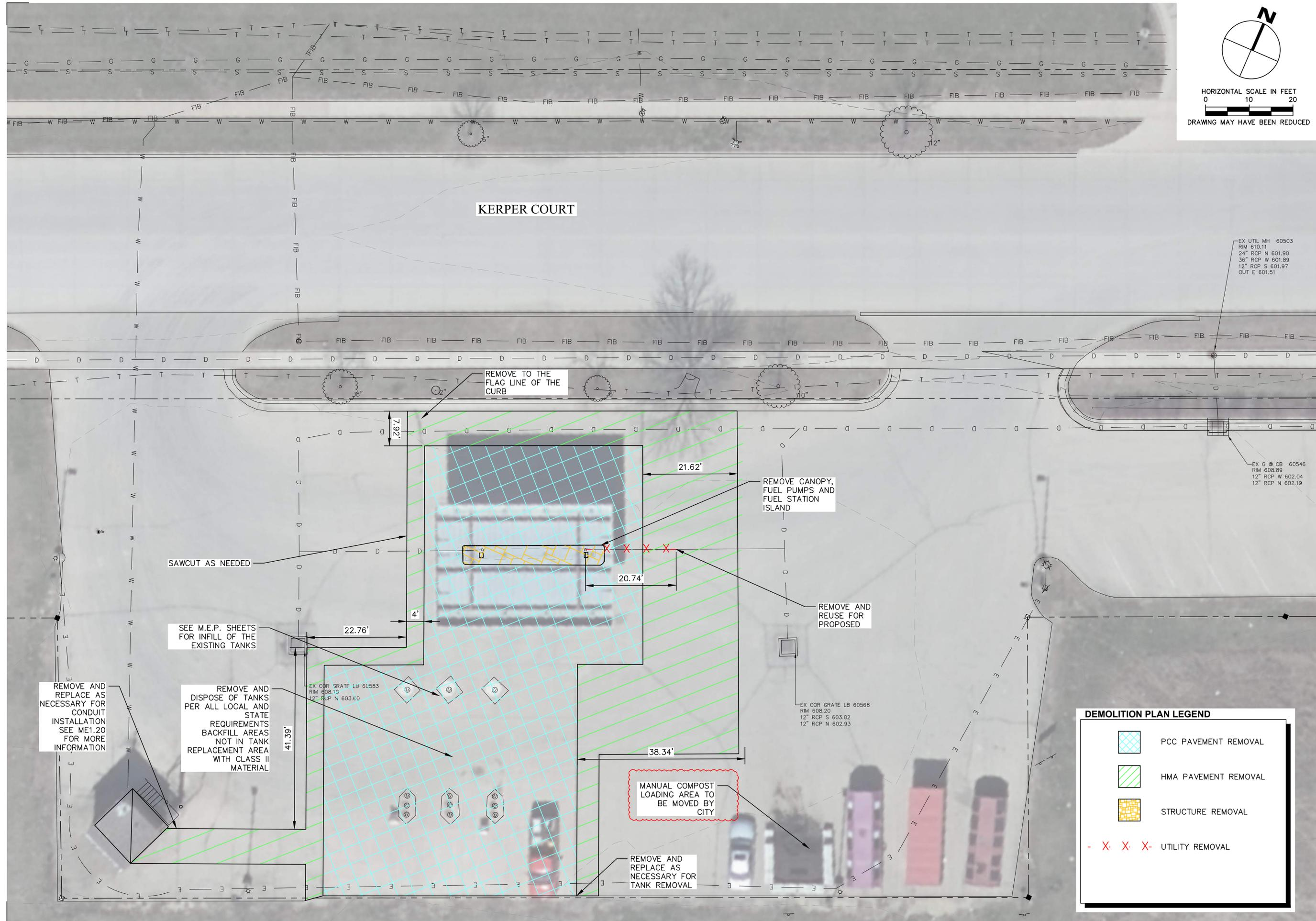

HORIZONTAL SCALE IN FEET  
 0 10 20  
 DRAWING MAY HAVE BEEN REDUCED

KERPER COURT

REMOVE TO THE  
 FLAG LINE OF THE  
 CURB

REMOVE CANOPY,  
 FUEL PUMPS AND  
 FUEL STATION  
 ISLAND

REMOVE AND  
 REUSE FOR  
 PROPOSED

MANUAL COMPOST  
 LOADING AREA TO  
 BE MOVED BY  
 CITY

REMOVE AND  
 REPLACE AS  
 NECESSARY FOR  
 TANK REMOVAL

EX UTIL MH 60503  
 RIM 610.11  
 24" RCP N 601.90  
 36" RCP W 601.89  
 12" RCP S 601.97  
 OUT E 601.51

EX C @ CB 60546  
 RIM 608.89  
 12" RCP W 602.04  
 12" RCP N 602.19

EX COR GRATE LB 60583  
 RIM 608.10  
 12" RCP N 603.80

EX COR GRATE LB 60568  
 RIM 608.20  
 12" RCP S 603.02  
 12" RCP N 602.93

**DEMOLITION PLAN LEGEND**

- PCC PAVEMENT REMOVAL
- HMA PAVEMENT REMOVAL
- STRUCTURE REMOVAL
- X X X - UTILITY REMOVAL

| Rev                         | Description         | Date                     |
|-----------------------------|---------------------|--------------------------|
| 2/4/2025                    | Issued For Bidding: | 2/4/2025                 |
| 2/4/2025 8:16 AM ANGE MAREK | Project Manager/LN  | Issued For Construction: |

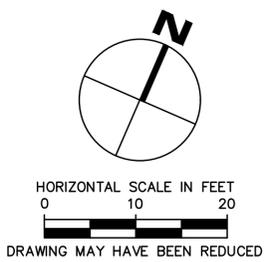
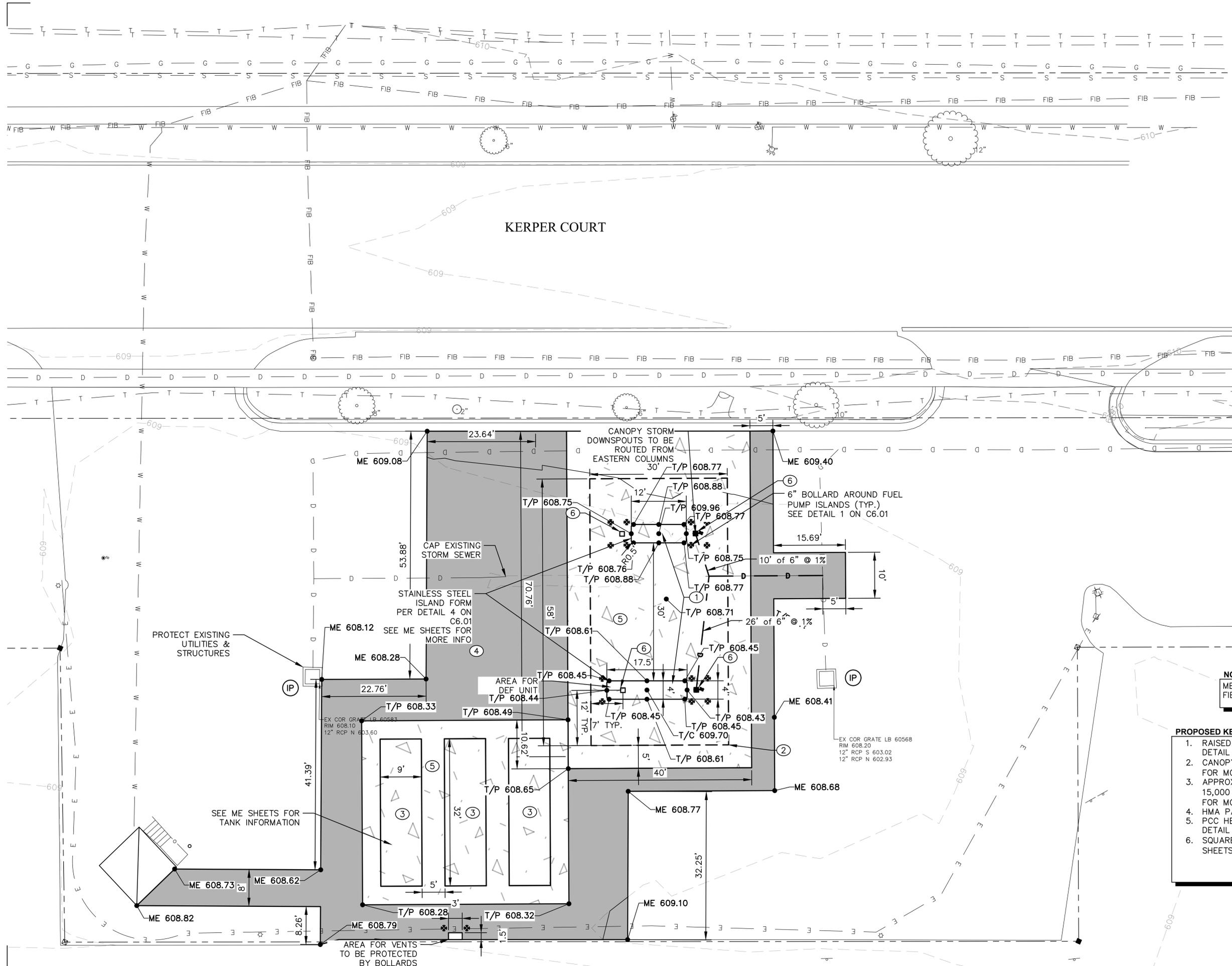

**NOTE**  
ME = MATCH EXISTING  
FIELD VERIFY ALL ME POINTS

- PROPOSED KEYED NOTES**
1. RAISED FUEL PUMP ISLAND PER DETAIL 1 SHEET C6.01
  2. CANOPY (30'x58') (SEE ME SHEETS FOR MORE INFO)
  3. APPROXIMATE UNDER GROUND 15,000 GAL. TANK (SEE ME SHEETS FOR MORE INFO)
  4. HMA PAVEMENT PATCH
  5. PCC HEAVY DUTY PAVEMENT PER DETAIL 2 SHEET C6.01
  6. SQUARE CANOPY COLUMN (SEE ME SHEETS FOR MORE INFO)

| Revisions | Rev | Description                 | Date                     |
|-----------|-----|-----------------------------|--------------------------|
|           |     | Project Number 24132        | 2/4/2025                 |
|           |     | Project Manager/LNR         | Issued For Bidding:      |
|           |     | 2/4/2025 8:16 AM ANGE MAREK | Issued For Construction: |

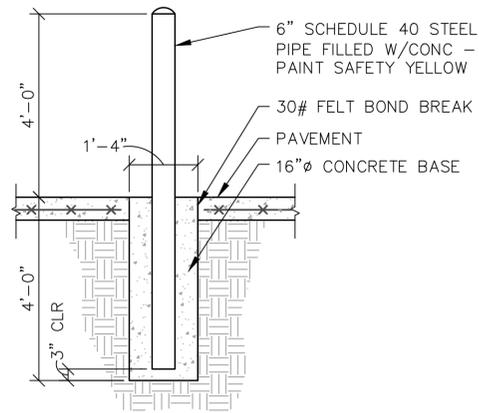

**1 BOLLARD**  
C6.01 NOT TO SCALE

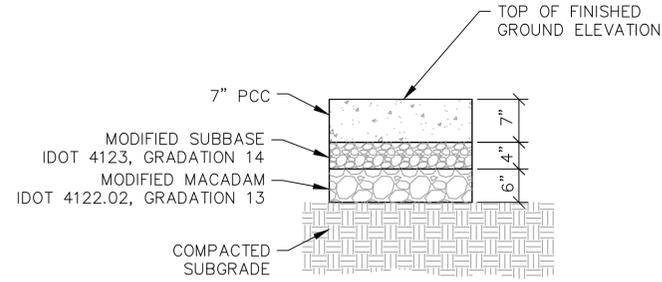

**2 PCC HEAVY DUTY PAVEMENT**  
C6.01 NOT TO SCALE

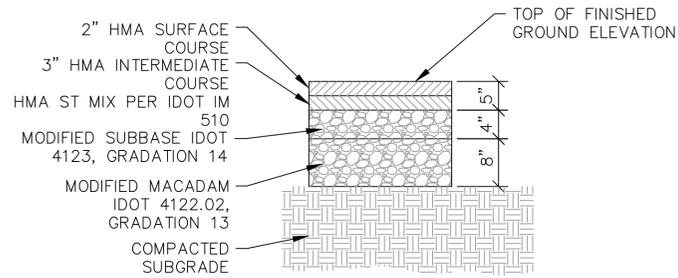

**3 HMA HEAVY DUTY PAVEMENT**  
C6.01 NOT TO SCALE

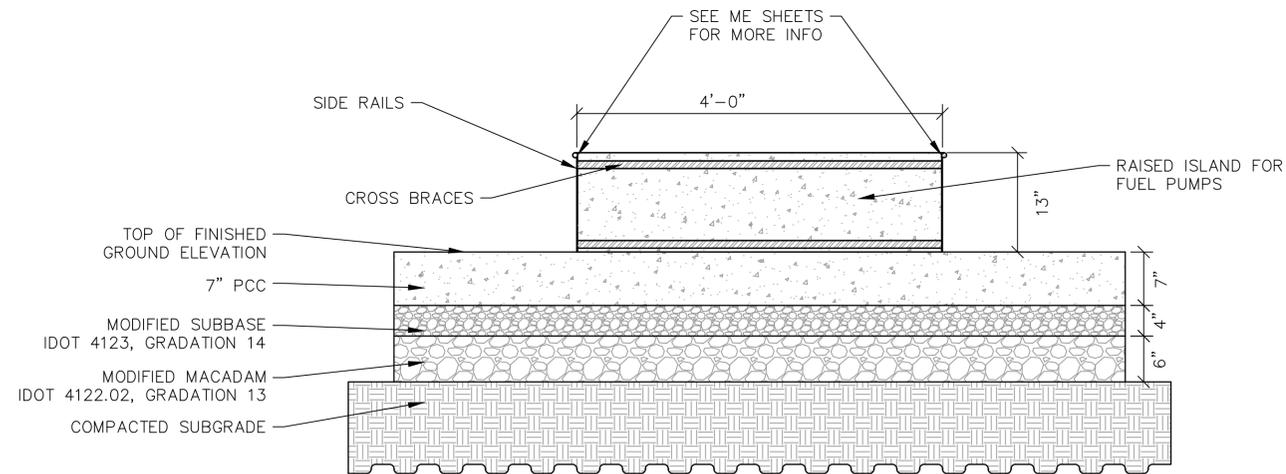

**4 STAINLESS STEEL FULL RADIUS ISLAND FORM**  
C6.01 RAISED FUEL PUMP ISLAND NOT TO SCALE

| Revisions | Rev | Description                           | Date                        |
|-----------|-----|---------------------------------------|-----------------------------|
|           |     | Project Number 24132                  | 2/4/2025                    |
|           |     | Project Manager LNR                   | Issued For Construction:    |
|           |     | P:\YAN\320\PRM\ISS\04\24132_ZZ-06.DWG | 2/4/2025 8:17 AM ANGE MAREK |

# FUELING STATION IMPROVEMENT PROJECT

925 KERPER CT. DUBUQUE, IA



WORKING ON TOMORROW.

800 556-4491  
origindesign.com

origindesign.com  
800 556-4491  
© Origin Design Co.



PROJECT LOCATION

## ELECTRICAL SYMBOLS LIST

NOTE: NOT ALL SYMBOLS SHOWN MAY BE REQUIRED FOR THIS PROJECT

### WIRING DEVICES

- DUPLEX WALL RECEPTACLE
- EMERGENCY PUSH BUTTON (FUEL SYSTEM)

### EQUIPMENT WIRING

- DISCONNECTING MEANS
- WEATHERPROOF DISCONNECTING MEANS
- FUSED DISCONNECTING MEANS
- MOTOR RATED SWITCH
- VARIABLE FREQUENCY DRIVE W/INTEGRAL DISCONNECT

### SWITCHES - LOW VOLTAGE (DIGITAL)

- EXTERIOR PHOTOCELL

### LUMINAIRES

- 2x2 SURFACE MOUNT TROFFER FIXTURE W/TYPE NUMBER
- SURFACE MOUNT LINEAR FIXTURE W/TYPE NUMBER
- WALL MOUNT LINEAR FIXTURE W/TYPE NUMBER
- SURFACE/CEILING MOUNT STRIP FIXTURE W/TYPE NUMBER
- SURFACE MOUNT FIXTURE W/TYPE NUMBER
- RECESSED DOWNLIGHT FIXTURE W/TYPE NUMBER
- PENDANT MOUNT FIXTURE W/TYPE NUMBER
- WALL MOUNT FIXTURE W/TYPE NUMBER
- POLE MOUNT FIXTURE W/TYPE NUMBER

### DISTRIBUTION

- SURFACE-MOUNT PANEL
- FLUSH-MOUNT PANEL
- TRANSFORMER
- CIT CABINET
- METER

### MISCELLANEOUS

- EXISTING - TO REMAIN
- EXISTING - TO BE RELOCATED
- EXISTING - TO BE REMOVED
- CONDUIT
- POINT OF NEW CONNECTION
- WEATHERPROOF



CITY OF DUBUQUE

FUELING STATION IMPROVEMENT PROJECT

Location / Description  
925 KERPER CT.  
DUBUQUE, IA

| Revisions | Rev | Description | Project Number | Project Manager | Issued For Bidding: | Issued For Construction: | Date |
|-----------|-----|-------------|----------------|-----------------|---------------------|--------------------------|------|
|           |     |             |                |                 |                     |                          |      |

COVER SHEET

ME0.01

**DEMOLITION GENERAL NOTES:**

- A. DEMOLITION DRAWINGS ARE BASED ON EXISTING AVAILABLE DRAWINGS AND CASUAL FIELD OBSERVATION. ELECTRICAL CONTRACTORS SHALL FIELD VERIFY THE SITE AND INCLUDE ALL REQUIRED DEMOLITION IN THE BID.
- B. ALL REQUIRED DEMOLITION IS NOT INDICATED. IT IS THE INTENT OF THESE DOCUMENTS THAT ALL MECHANICAL AND ELECTRICAL SYSTEMS (NOT TO BE REUSED OR EXTENDED) BE REMOVED. COORDINATE WITH ARCHITECTURAL DRAWINGS.
- C. REFER TO SPECIFICATIONS AND OTHER SHEETS FOR ADDITIONAL DEMOLITION REQUIREMENTS.
- D. REMOVE ALL ELECTRICAL CONNECTIONS, WIRING, CONDUIT, CONTROLS SERVING ALL FUEL SYSTEM EQUIPMENT AND CANOPY LIGHTING.
- E. REFER TO CIVIL DRAWINGS FOR DETAILS ON FLOOR CUTTING. CONTRACTOR SHALL COORDINATE WORK TO BE CONSISTENT WITH SCOPE OF GENERAL CONTRACTOR'S DEMOLITION.

**DEMOLITION REFERENCED NOTES:** (7)

- (NOT ALL NOTES MAY BE APPLICABLE TO THIS SHEET)
- 1. ELECTRICAL CONTRACTOR SHALL REMOVE ALL ELECTRICAL DEVICES SERVING FUEL DISPENSER AND ASSOCIATED CONDUCTORS. REMOVE ALL CONDUIT BELOW GRADE AND ABOVE GRADE. CONDUIT MAY BE ABANDONED AND CAPPED AT THE WATER HOUSE WHEN NECESSARY.
  - 2. CONTRACTOR TO REMOVE AND DISPOSE OF FUEL DISPENSER AND ASSOCIATED EQUIPMENT/ PIPING.
  - 3. ELECTRICAL CONTRACTOR SHALL REMOVE ALL ELECTRICAL DEVICES AND ASSOCIATED CONDUCTORS SERVING FUEL TANK PUMPS COMPLETELY. REMOVE ALL BELOW GRADE CONDUIT EXPOSED FROM EXCAVATION AND ABOVE GRADE CONDUIT. COORDINATE REMOVAL WITH GENERAL CONTRACTOR. CAP ABANDONED CONDUIT AT WATER HOUSE.
  - 4. REFER TO CIVIL DRAWINGS FOR DEMOLITION OF UNDERGROUND FUEL TANKS.
  - 5. ELECTRICAL CONTRACTOR SHALL FURNISH AND INSTALL NEW BREAKERS IN PANEL F12 TO SERVE BOTH EXISTING AND NEW LOADS. FIELD VERIFY ALL EXISTING BREAKER SIZES PRIOR TO CONSTRUCTION.
  - 6. REMOVE WATER DISPENSING CONTROLS AND SIGNAGE. PREPARE LOCATION FOR NEW EQUIPMENT AND SIGNAGE.
  - 7. REMOVE FUEL TANK MONITOR CONTROL PANEL AND ALL ASSOCIATED CONDUIT AND WIRING. PATCH TO MATCH EXISTING.
  - 8. REMOVE WATER DISPENSING CONTROLLER AND ALL ASSOCIATED WIRING. PREPARE LOCATION FOR NEW EQUIPMENT.

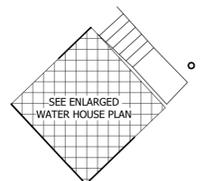
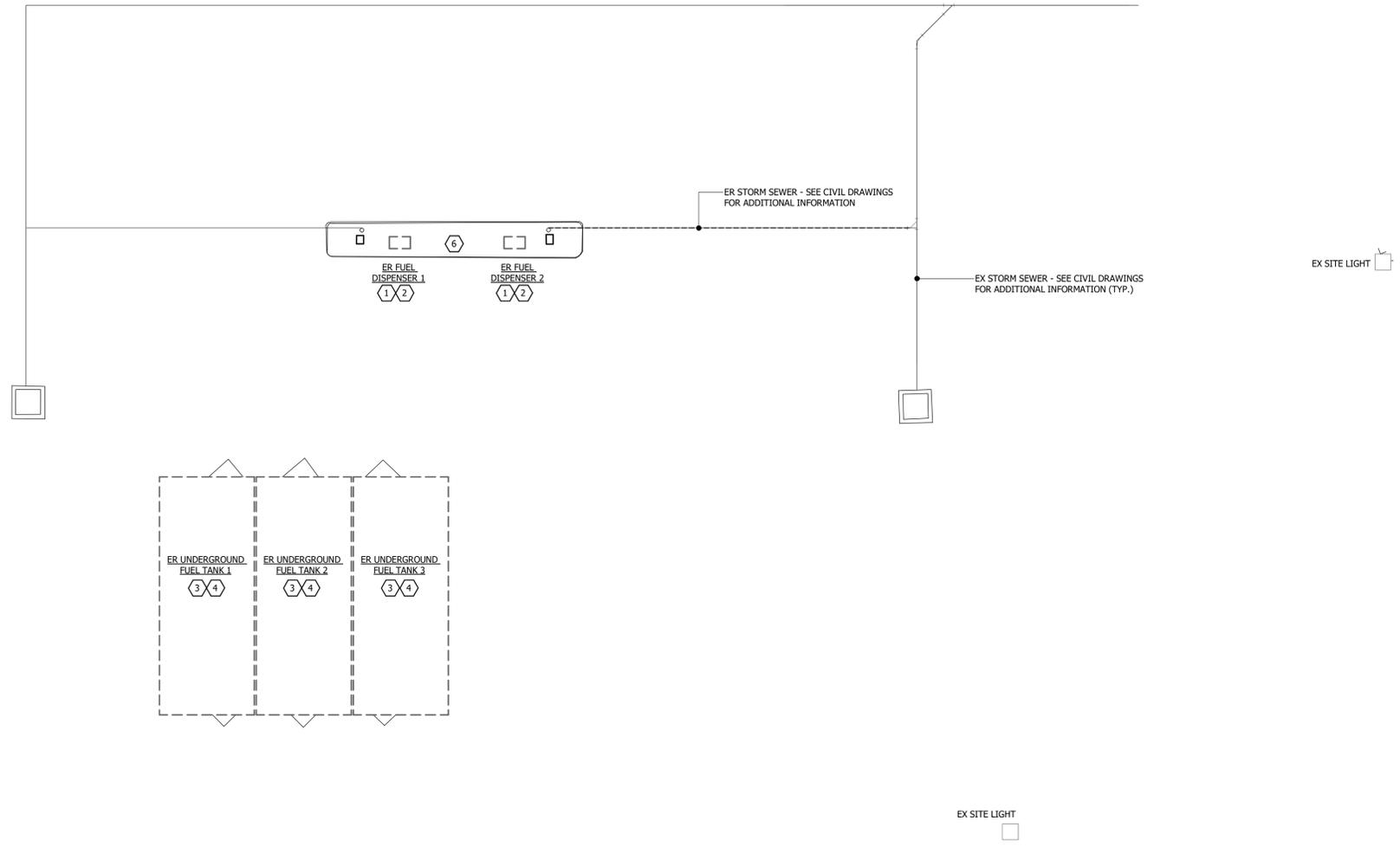

**1 MECHANICAL AND ELECTRICAL DEMOLITION PLAN**  
1" = 10'-0"

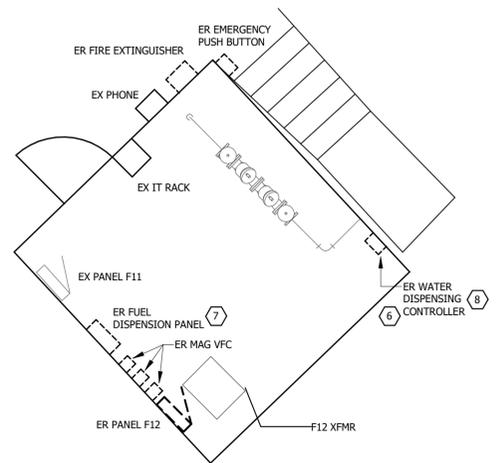

**3 WATER HOUSE MECHANICAL AND ELECTRICAL DEMOLITION PLAN**  
1/4" = 1'-0"



ER FUEL DISPENSION PANEL AND ASSOCIATED POWER SUPPLY IN PUMP HOUSE



EX WATER SERVICE ENTRANCE IN PUMP HOUSE



ER WATER DISPENSION CONTROLS AND ASSOCIATED SIGNAGE

| Revisions | Rev | Description | Project Number | Project Manager | Issued For Bidding | Issued For Construction | Date |
|-----------|-----|-------------|----------------|-----------------|--------------------|-------------------------|------|
|           |     |             |                |                 |                    |                         |      |

**GENERAL NOTES:**

- A. ALL DISCONNECTS ON MECHANICAL EQUIPMENT SHALL BE MOUNTED ON STRUCTURE TO ALLOW REMOVAL OF THE EQUIPMENT FOR MAINTENANCE WITH A MINIMUM OF WIRING WORK. VERIFY NEC CLEARANCE REQUIREMENTS ARE MET PRIOR TO ROUGH-IN.
- B. MAINTAIN SERVICE CLEARANCE AROUND ALL MECHANICAL & ELECTRICAL EQUIPMENT. DO NOT ROUTE PIPING OR CONDUIT IN CLEARANCE SPACE.
- C. ALL RECEPTACLE CIRCUITS SHALL HAVE DEDICATED NEUTRALS.
- D. PROVIDE PVC SCH 40 CONDUIT WITH RIGID TURN UP WITHIN EQUIPMENT UNLESS OTHERWISE NOTED.
- E. INSTALL ALL FUEL EQUIPMENT PER MANUFACTURER'S RECOMMENDATIONS AND REQUIREMENTS.
- F. CONDUIT LAYOUT IS SCHEMATIC IN NATURE, NOT ALL OFFSETS OR SPACING MAY BE SHOWN. CONTRACTOR SHALL SITE VERIFY.
- G. LOCATE LIGHTING TO BE IN-LINE WITH CANOPY PANELS. CONFIRM WITH DESIGN TEAM.
- H. PROVIDE ALL LOCAL AND STATE PERMITS AND INSPECTIONS, INCLUDING ALL APPROPRIATE FEES.
- I. INSTALL UNDERGROUND TANKS WITH A MINIMUM OF 4' COVER.

**REFERENCED NOTES:**

- (NOT ALL NOTES MAY BE APPLICABLE TO THIS SHEET)
- 1. PROVIDE FIRE EXTINGUISHER AND EXTERIOR RATED CABINET IN ACCORDANCE TO THE STATE FIRE MARSHAL REQUIREMENTS.
- 2. COORDINATE PANEL LOCATIONS WITH DESIGN TEAM.
- 3. 4" PVC SCH 40 ROOF DRAIN WITHIN COLUMN. CONNECT TO UNDER GRADE STORM SEWER. SEE CIVIL PLANS FOR CONTINUATION.
- 4. ELECTRICAL CONTRACTOR SHALL FURNISH AND INSTALL STEM SWIVEL MOUNT PHOTOCELL EQUAL TO #EK42365 TO CONTROL EXTERIOR LIGHTING. COORDINATE FOR NORTH FACING INSTALLATION.
- 5. DC POWER SHALL BE 18 GAUGE 2 CONDUCTOR TWISTED AND SHIELDED WITH DRAIN AND TEFLON COATING. ELECTRICAL CONTRACTOR SHALL FURNISH AND INSTALL ALL DC WIRING SERVING FLOAT SENSORS, SLUMP SENSORS, AND PROBES AS REQUIRED FOR A COMPLETE AND WORKING SYSTEM.
- 6. ELECTRICAL CONTRACTOR SHALL FURNISH AND INSTALL BREAKAWAY T-BASE TO SERVE TYPE SA FIXTURE. PROVIDE LIGHT POLE BASE PLATE ADAPTOR TO UTILIZE THE CANOPY COLUMN FOUNDATION FOR LIGHT FIXTURE POLE BASE.
- 7. EMERGENCY PUSH BUTTON SHALL DISCONNECT POWER TO ALL DISPENSING DEVICES; TO ALL REMOTE PUMPS SERVING THE DISPENSING DEVICES; TO ALL ASSOCIATED POWER, CONTROL, AND SIGNAL CIRCUITS; AND TO ALL OTHER ELECTRICAL EQUIPMENT IN THE HAZARDOUS (CLASSIFIED) LOCATIONS SURROUNDING THE FUEL DISPENSING DEVICES. INSTALLATION SHALL BE COMPLIANT WITH NEC SECTION 514.
- 8. ELECTRICAL CONTRACTOR SHALL ROUGH-IN FOR FUEL PUMP EMERGENCY STOP REUSE EXISTING RACEWAY AS NEEDED. REFER TO EMERGENCY FUELING STATION SHUTOFF WITH COVER ON SHEET ME2.10 FOR MORE INFORMATION
- 9. ELECTRICAL CONTRACTOR SHALL PROVIDE ALL CONDUITS WITH EXPLOSION PROOF SEAL OFFS AS PER NEC REQUIREMENTS. SEE DETAILS ON SHEET ME2.10 FOR MORE INFORMATION REGARDING SEAL OFF INSTALLATION AND STUB UP SPACING.
- 10. CANOPY STORM DOWNSPOUTS SHALL BE ROUTED FROM THE EASTERN COLUMNS TO THE UNDERGROUND STORM SEWER. REFER TO CIVIL PLANS FOR ADDITIONAL INFORMATION INCLUDING PIPE SIZES AND MATERIAL.
- 11. COORDINATE VARIABLE FREQUENCY CONTROLLERS (VFC) LOCATIONS WITH DESIGN TEAM.
- 12. PROVIDE 72" PEDESTAL (POWDER COATED WHITE) AND INSTALL THE TANK OVERFLOW SHUTOFF/ALARM. PROVIDE PEDESTAL WITH CONCRETE BASE EXTENDING 48" BELOW GRADE AND LOCATE BETWEEN BOLLARDS.
- 13. PROVIDE SINGLE-POINT POWER CONNECTION BETWEEN INDOOR UNIT AND OUTDOOR UNIT. COORDINATE INSTALLATION WITH MECHANICAL CONTRACTOR.

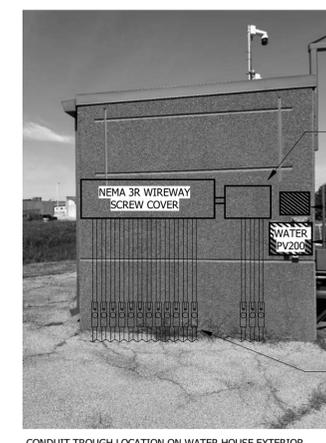
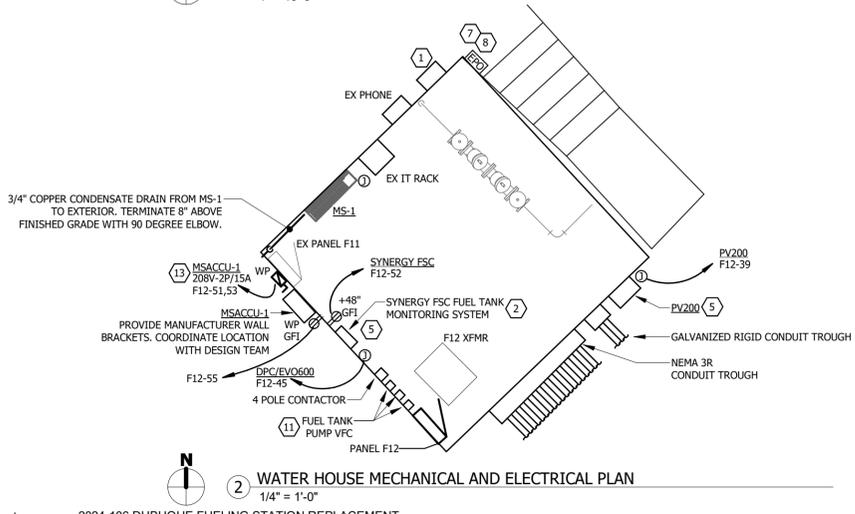
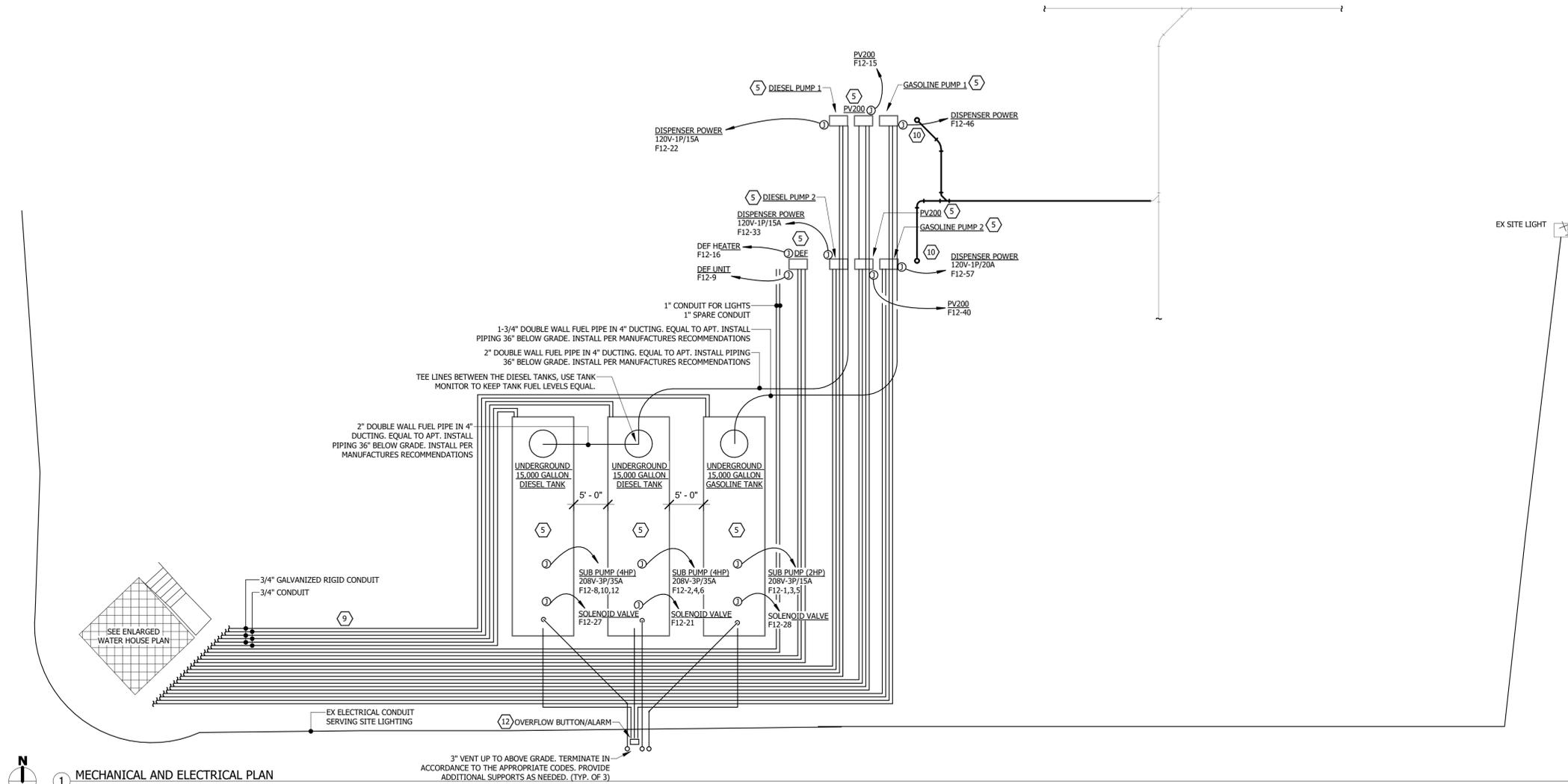

- CONDUITS SERVING TANK SUBMERSIBLE PUMPS IN SEPARATE ENCLOSURE
- REPLACE EXISTING SIGNAGE WITH NEW
- REPLACE EXISTING BULK WATER USAGE START/STOP CONTROLS
- EXACT QUANTITY OF BURIED CONDUITS NOT SHOWN. CONDUITS AND CONDUCTORS SHALL ROUTE TO SITE EQUIPMENT SUCH AS FUEL DISPENSERS, AND CANOPY LIGHTS.



WORKING ON TOMORROW.

800 556-4491  
origindesign.com

origindesign.com  
800 556-4491  
© Origin Design Co.



CITY OF DUBUQUE

FUELING STATION IMPROVEMENT PROJECT

Location / Description  
925 KERPER CT.  
DUBUQUE, IA

| Revisions | Rev | Description     | Date                     |
|-----------|-----|-----------------|--------------------------|
|           |     | Project Number  | Issued For Bidding:      |
|           |     | Project Manager | Issued For Construction: |

COVER SHEET

ME1.20

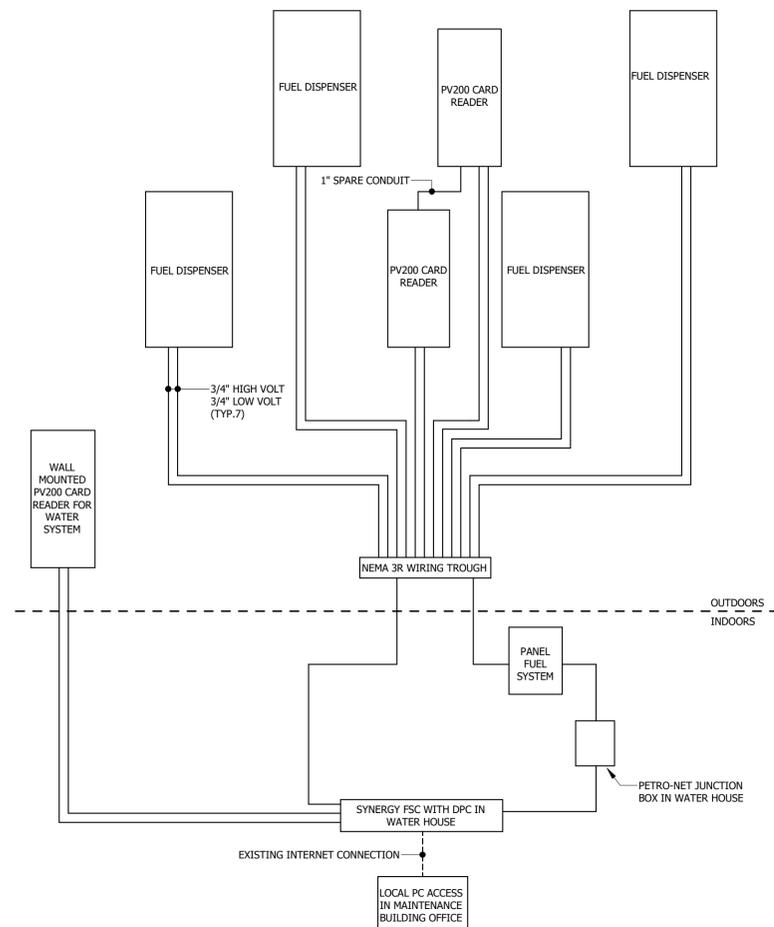

1 GENERAL SYSTEM WIRING SCHEMATICS  
No Scale

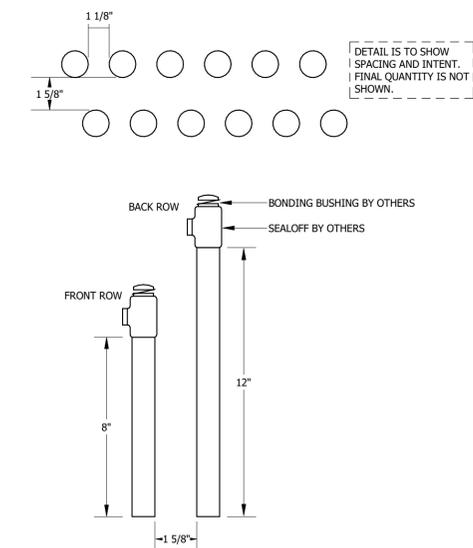

2 FUEL CONDUITS STUB UP AND SPACING  
No Scale

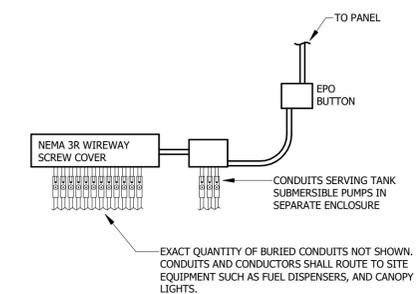

4 EXTERIOR ROUTING ELEVATIONS SCHEMATIC  
No Scale

3 EMERGENCY SHUTOFF WITH COVER  
No Scale

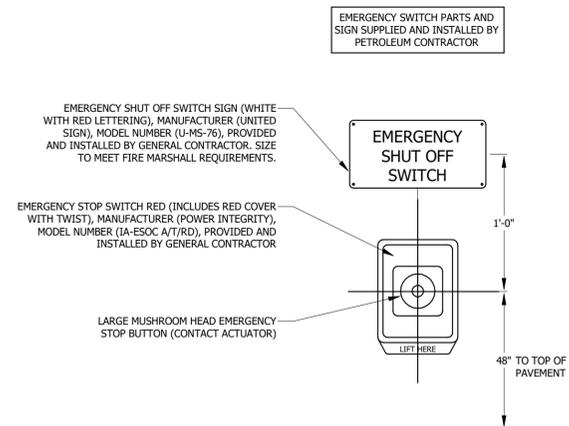

5 SEAL FITTING INSTALLATION  
No Scale

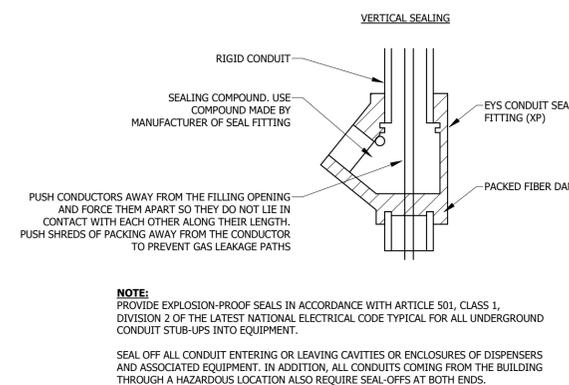

6 CANOPY FOOTER DETAIL  
No Scale

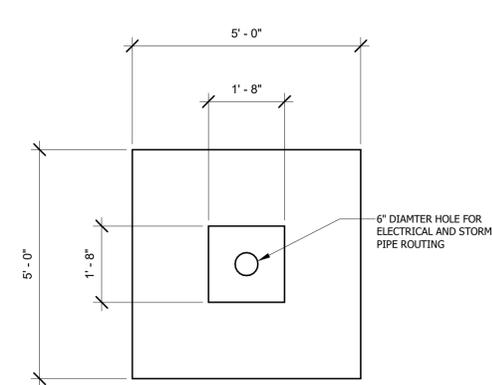

GENERAL NOTES:

- MAINTAIN ALL SERVICE CLEARANCES REQUIRED BY THE UTILITY.
- UTILITY CONTACT: ALLIANT ENERGY
- INSTALL ALL CONDUCTORS PER MANUFACTURER'S RECOMMENDATIONS.
- CONTRACTOR SHALL ACCOUNT FOR VOLTAGE DROPS FOR PATHS GREATER THEN 75 FEET.

REFERENCED NOTES:

- REFER TO SCHEDULE FOR ADDITIONAL BREAKERS AND PANEL INFORMATION.
- ELECTRICAL CONTRACTOR SHALL REFEED NEW PANEL F12 AND ASSOCIATED 4 POLE CONTACTOR FROM PANEL FEED PREVIOUSLY SERVING REMOVED PANEL F12.

COPPER CONDUCTOR AND CONDUIT SIZING CHART

|       | CONDUCTORS (THWN-2) |         |         | CONDUIT |        | PARALLEL RUNS |
|-------|---------------------|---------|---------|---------|--------|---------------|
|       | PHASE               | NEUTRAL | GROUND  | EMT     | SCH 40 |               |
| 15/4  | (3) #12 AWG         | #12 AWG | #12 AWG | 3/4"    | 3/4"   | 1             |
| 20/4  | (3) #12 AWG         | #12 AWG | #12 AWG | 3/4"    | 3/4"   | 1             |
| 25/4  | (3) #10 AWG         | #10 AWG | #10 AWG | 3/4"    | 3/4"   | 1             |
| 30/4  | (3) #10 AWG         | #10 AWG | #10 AWG | 3/4"    | 3/4"   | 1             |
| 35/4  | (3) #8 AWG          | #8 AWG  | #10 AWG | 3/4"    | 3/4"   | 1             |
| 40/4  | (3) #8 AWG          | #8 AWG  | #10 AWG | 3/4"    | 3/4"   | 1             |
| 45/4  | (3) #8 AWG          | #8 AWG  | #10 AWG | 3/4"    | 3/4"   | 1             |
| 50/4  | (3) #8 AWG          | #8 AWG  | #10 AWG | 3/4"    | 3/4"   | 1             |
| 60/4  | (3) #6 AWG          | #6 AWG  | #10 AWG | 1"      | 1"     | 1             |
| 70/4  | (3) #4 AWG          | #4 AWG  | #8 AWG  | 1-1/4"  | 1-1/4" | 1             |
| 80/4  | (3) #4 AWG          | #4 AWG  | #8 AWG  | 1-1/4"  | 1-1/4" | 1             |
| 90/4  | (3) #3 AWG          | #3 AWG  | #8 AWG  | 1-1/4"  | 1-1/4" | 1             |
| 100/4 | (3) #3 AWG          | #3 AWG  | #8 AWG  | 1-1/4"  | 1-1/4" | 1             |

7 ELECTRICAL ONE LINE DIAGRAM DBQ  
No Scale

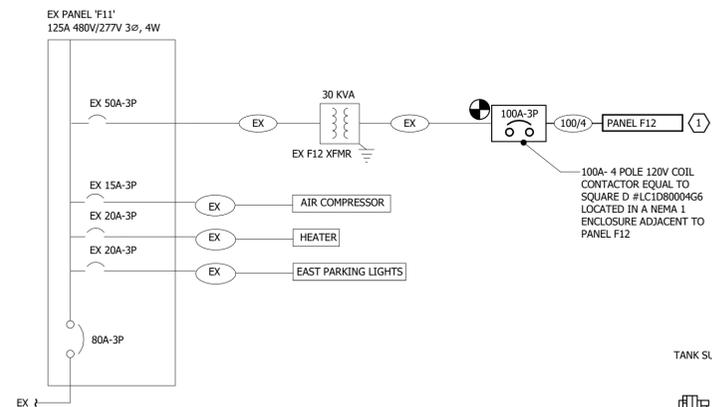

TANK SUMP PIPEWORK DETAIL

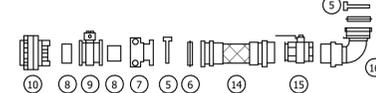

TRANSITION SUMP PIPEWORK DETAIL

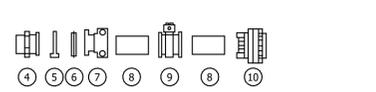

- 1 UNIVERSAL LIQUID SUMP SENSOR
- 2 SENSOR CAP INSTALLATION KIT
- 3 ELECTRICAL CONDUIT ENTRY BOOT (3/4")
- 4 EZ FIT FLANGE X HEX MALE ADAPTER (1-1/2")
- 5 EZ FIT CLAMP
- 6 EZ FIT GASKET
- 7 QUICK RELEASE FITTING (1-1/2")
- 8 XP FLEXIBLE DOUBLE WALL PIPE (1-1/2")
- 9 SPLIT TEST BOOT (1-1/2")
- 10 ENTRY BOOT

8 15,000 GALLON GLASS STEEL II FUEL TANK DETAIL  
No Scale

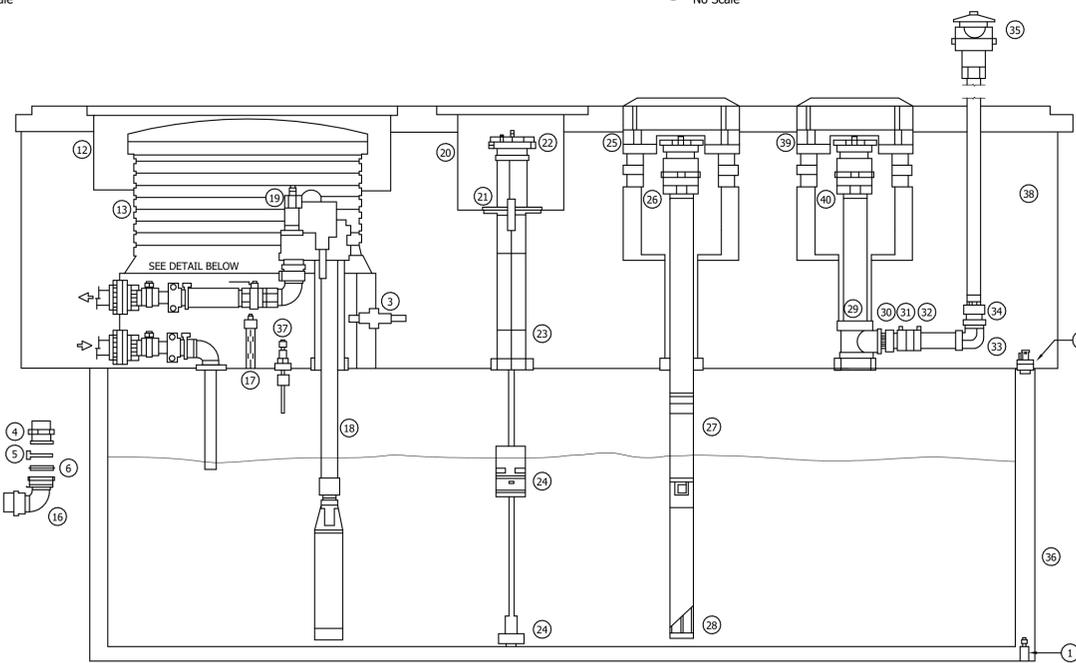

- 11 BLACK STEEL REDUCING ELBOW (1-1/2" TO 1")
- 12 BOLT-DOWN MANWAY (24")
- 13 WATER RESISTANT TANK SUMP
- 14 FLEXIBLE CONNECTOR (EZ FLANGE X MALE)
- 15 BALL VALVE (2")
- 16 EZ FIT 90° ELBOW FLANGE X MALE ADAPTER
- 17 DISCRIMINATING SUMP SENSOR
- 18 SUBMERSIBLE PUMP (3/4 HP)
- 19 ELECTRONIC LINE LEAK DETECTION
- 20 PROBE ACCESS MANHOLE
- 21 ENTRY BOOT (4")
- 22 PROBE CAP AND ADAPTER (FOR 4" RISERS)
- 23 INVENTORY CONTROL PROBE
- 24 DIESEL DENSITY FLOAT KIT (4")
- 25 DOUBLE WALL SPILL CONTAINER
- 26 SWIVEL ADAPTER KIT
- 27 OVERFILL PREVENTION VALVE (5' TOP 8' BOTTOM)
- 28 TANK BOTTOM PROTECTOR
- 29 EXTRACTOR VENT VALVE (4" x 4" x 2")
- 30 MALE TERMINATION FITTING (2")
- 31 ELECTROFUSION COUPLER (2")
- 32 UPP 2" SEMI-RIGID PIPE (19' STICK)
- 33 ELECTROFUSION 90° ELBOW
- 34 FEMALE TERMINATION FITTING (2")
- 35 P/V VENT WITH IN-LINE VAULT WITH US P/V AND RAIN CAP
- 36 MAIN TANK (DOUBLE WALL)
- 37 HIGH LEVEL SENSOR
- 38 3/8" CHIP OR 3/8" PEA GRAVEL BACKFILL
- 39 DOUBLE WALL VAPOR SPILL CONTAINER
- 40 VAPOR SWIVEL ADAPTER KIT

| Revisions | Rev | Description | Project Number | Project Manager | Date |
|-----------|-----|-------------|----------------|-----------------|------|
|           |     |             |                |                 |      |

| FUEL STATION EQUIPMENT SCHEDULE      |  |    |   |
|--------------------------------------|--|----|---|
| #                                    | DESCRIPTION  | #  | DESCRIPTION   |
| <b>UNDERGROUND TANKS DOUBLE WALL</b> |  |    |   |
| 1                                    | (3) 15,000 GLASS STEEL II UNDERGROUND TANKS WITH FIBERGLASS WRAP. (32' LONG x 108" DIAMETER)           | 28 | <b>PUMP ACCESSORIES</b>   |
| 1A                                   | TANK HOLD-DOWN STAPS AND CONCRETE DEADMAN ANCHORS FOR EACH TANK.                                       | 28 | (1) 2HP VARIABLE SPEED SUBMERSIBLE PUMP FOR GAS MODEL STPMVS2-YL2-12    |
|                                      |  | 29 | (2) 4HP VARIABLE SPEED SUBMERSIBLE PUMP FOR DIESEL MODEL STPMVS4-VL2-12 |
|                                      |  | 30 | MAG VFC CONTROLLER FOR EACH PUMP  |
| <b>FUEL CONTROL SYSTEM</b>           |  |    |   |
| 2                                    | DX FLEET/PETRO VEND SYNERGY FUEL SITE CONTROLLER WEB BASED PLATFORM                                    |    |   |
| 3                                    | DPC REMOTE MOUNT INTERFACE MODULE AND SOFTWARE   |    |   |
| 4                                    | PETRO VEND AVI   |    |   |
| 5                                    | (700) VEHICLE MONITORING SYSTEM DRIVER IDENTIFICATION CARDS  |    |   |
| 5A                                   | (500) MILEAGE PACKAGE, (200) ENGINE HOURS PACKAGE, (50) PASSIVE TAGS. (3) DAYS OF AVI ON-SITE TRAINING |    |   |
| <b>TANK AND SUMP MONITORING</b>      |  |    |   |
| 6                                    | INVENTORY ONLY PROBE, LEAK DETECTION PROBE, ELECTRIC LINE LEAK, AND ACCESSORIES                        |    |   |
| 7                                    | FRANKLIN EVO600 WITH DISPLAY, HARDWIRED PRINTER, AND NECESSARY MODULES                                 |    |   |
| 8                                    | UNIVERSAL LIQUID SUMP SENSOR AT TANKS, PIPING TANK SUMP, AND EACH DISPENSER SUMP                       |    |   |
| <b>SUMPS AND MANHOLES</b>            |  |    |   |
| 9                                    | SINGLE WALL FIBERGLASS TANK SUMP   |    |   |
| 10                                   | SINGLE WALL FIBERGLASS DISPENSER SUMP  |    |   |
| 11                                   | DISPENSER SUMP COMPATIBLE FOR WAYNE SELECT DISPENSER   |    |   |
| <b>WAYNE DISPENSERS</b>              |  |    |   |
| 12                                   | 50 GPM, 3/G7232D SHC DIESEL, 1 PRODUCT, 2 HOSES, 4 METERS  |    |   |
| 13                                   | 22 GPM, E3/G72021 PRODUCT, 2 HOSES, 2 METERS   |    |   |
| 14                                   | HOSE MAST AND SPRING LOAD 3/4" EXPLOSION PROOF FLEX (NO SPRING REQUIRED)                               |    |   |
| <b>ISLAND FORMS AND ACCESSORIES</b>  |  |    |   |
| 15                                   | 15' X 48" X 13" X 6" RADIUS STAINLESS STEEL  |    |   |
| 16                                   | SHEAR VALVES   |    |   |
| <b>TESTING</b>                       |  |    |   |
| 17                                   | DIESEL SYSTEM TESTING  |    |   |
| 18                                   | GAS SYSTEM TESTING   |    |   |
| 19                                   | SUMP HYDRO TESTING- TRANSITION AND DISPENSER SUMPS   |    |   |
| <b>DISPENSING ACCESSORIES</b>        |  |    |   |
| 20                                   | (3) 1" DIESEL NOZZLE HIGH SPEED HUSKEY 1 + 8 (DIESEL COMMERCIAL NOZZLE)                                |    |   |
| 21                                   | (1) 3/4" DIESEL HIGH PRESSURE NOZZEL   |    |   |
| 22                                   | MAGNETIC BREAKAWAY NOZZLES   |    |   |
| 22                                   | 1" BREAKAWAY HOSE  |    |   |
| 23                                   | 1" X 14' CURB HOSE   |    |   |
| 24                                   | 3/4" NOLEAD NOZZLE   |    |   |
| 25                                   | 3/4" SWIVEL  |    |   |
| 26                                   | 3/4" BREAKAWAY HOSE  |    |   |
| 27                                   | 3/4" X 14' CURB HOSE   |    |   |

| DUCTLESS MINI-SPLIT SYSTEM SCHEDULE |              |            |                        |              |            |                        |   |                   |     |      |                |
|-------------------------------------|--------------|------------|------------------------|--------------|------------|------------------------|---|-------------------|-----|------|----------------|
| INDOOR UNIT                         |              |            |                        | OUTDOOR UNIT |            |                        |   | ELECTRICAL        |     |      |                |
| UNIT TAG                            | MANUFACTURER | MODEL      | COOLING CAPACITY (MBH) | UNIT TAG     | MODEL      | COOLING CAPACITY (BTH) | OUTDOOR AMBIENT TEMPERATURE RANGE (°F-°F) | EFFICIENCY (SEER) | MCA | MOCP | VOLTAGE/ PHASE |
| MS-1                                | mitsubishi   | MSZ-HM12NA | 12,000                 | MSACCU-1     | MSZ-HM12NA | 12,000                 | 105                                       | 19                | 15  | 20   | 208/1          |

- NOTES:
- PROVIDE WITH INTEGRAL THERMOSTAT.
  - UNIT SHALL HAVE SINGLE POINT POWER CONNECTION.
  - SIZE REFRIGERANT LINES PER MANUFACTURER RECOMMENDATIONS.
  - APPROVED MANUFACTURERS: MITSUBISHI, FUJITSU, FRIEDRICH, LG, DAIKIN, PANASONIC, ENGINEER APPROVED EQUAL.

| BRANCH PANEL F12  |                     |               |                  |                            |             |         |          |                         |      |      |       |      |      |                     |        |
|---|---------------------|---------------|------------------|----------------------------|-------------|---------|----------|-------------------------|------|------|-------|------|------|---------------------|--------|
| Location: F12 XFMR  |                     |               |                  | Volts: 120/208 Wye         |             |         |          | S.C.C.R. Rating: 10,000 |      |      |       |      |      |                     |        |
| Supply From: F12 XFMR   |                     |               |                  | Phases: 3                  |             |         |          | Mains Type: MCB         |      |      |       |      |      |                     |        |
| Mounting: Surface   |                     |               |                  | Wires: 4                   |             |         |          | Mains Rating: 100A      |      |      |       |      |      |                     |        |
| Enclosure: Type 1   |                     |               |                  |                            |             |         |          | MCB Rating: 100A        |      |      |       |      |      |                     |        |
|   |                     |               |                  |                            |             |         |          | SPD: NONE               |      |      |       |      |      |                     |        |
| Notes: ELECTRICAL CONTRACTOR SHALL FURNISH AND INSTALL BREAKERS FOR ALL NEW AND EXISTING LOADS BEING REFINED IN ADDITION TO NEW BREAKERS... |                     |               |                  |                            |             |         |          |                         |      |      |       |      |      |                     |        |
| CKT   | Circuit Description | Type          | Trip             | Poles                      | A           |         | B        |                         | C    |      | Poles | Trip | Type | Circuit Description | CKT    |
| F12-1   | SUB PUMP (2HP)      | N             | 15 A             | 3                          | 936         | 2100    |          |                         |      |      | 3     | 35 A | N    | SUB PUMP (4HP)      | F12-2  |
| F12-3   | --                  |               | --               | --                         |             |         | 936      | 2100                    |      |      | --    | --   | --   |                     | F12-4  |
| F12-5   | --                  |               | --               | --                         |             |         |          |                         | 936  | 2100 | --    | --   | --   |                     | F12-6  |
| F12-7   | SPACE               |               | --               | 1                          | --          | 2100    |          |                         |      |      | 3     | 35 A | N    | SUB PUMP (4HP)      | F12-8  |
| F12-9   | DEF UNIT            | N             | 20 A             | 1                          |             |         | 1920     | 2100                    |      |      | --    | --   | --   |                     | F12-10 |
| F12-11  | SWITCHED NEUTRAL    |               | --               | 1                          |             |         |          |                         | --   | 2100 | --    | --   | --   |                     | F12-12 |
| F12-13  | SPACE               |               | --               | 1                          | --          | --      |          |                         |      |      | 1     | --   |      | SPACE               | F12-14 |
| F12-15  | PV200               | N             | 20 A             | 1                          |             |         | 1920     | 1920                    |      |      | 1     | 20 A | N    | DEF HEATER          | F12-16 |
| F12-17  | SWITCHED NEUTRAL    |               | --               | 1                          |             |         |          |                         | --   | --   | 1     | --   |      | SWITCHED NEUTRAL    | F12-18 |
| F12-19  | SPACE               |               | --               | 1                          | --          | --      |          |                         |      |      | 1     | --   |      | SPACE               | F12-20 |
| F12-21  | SOLENOID VALVE      | N             | 20 A             | 1                          |             |         | 500      | 192                     |      |      | 1     | 15 A | N    | DISPENSER POWER     | F12-22 |
| F12-23  | SWITCHED NEUTRAL    |               | --               | 1                          |             |         |          |                         | --   | --   | 1     | --   |      | SWITCHED NEUTRAL    | F12-24 |
| F12-25  | SPACE               |               | --               | 1                          | --          | --      |          |                         |      |      | 1     | --   |      | SPACE               | F12-26 |
| F12-27  | SOLENOID VALVE      | N             | 20 A             | 1                          |             |         | 500      | 500                     |      |      | 1     | 20 A | N    | SOLENOID VALVE      | F12-28 |
| F12-29  | SWITCHED NEUTRAL    |               | --               | 1                          |             |         |          |                         | --   | --   | 1     | --   |      | SWITCHED NEUTRAL    | F12-30 |
| F12-31  | SPACE               |               | --               | 1                          | --          | --      |          |                         |      |      | 1     | --   |      | SPACE               | F12-32 |
| F12-33  | DISPENSER POWER     | N             | 15 A             | 1                          |             |         | 192      | 153                     |      |      | 1     | 20 A | N    | Lighting            | F12-34 |
| F12-35  | SWITCHED NEUTRAL    |               | --               | 1                          |             |         |          |                         | --   | --   | 1     | --   |      | SWITCHED NEUTRAL    | F12-36 |
| F12-37  | SPACE               |               | --               | 1                          | --          | --      |          |                         |      |      | 1     | --   |      | SPACE               | F12-38 |
| F12-39  | PV200               | N             | 20 A             | 1                          |             |         | 500      | 1920                    |      |      | 1     | 20 A | N    | PV200               | F12-40 |
| F12-41  | SWITCHED NEUTRAL    |               | --               | 1                          |             |         |          |                         | --   | --   | 1     | --   |      | SWITCHED NEUTRAL    | F12-42 |
| F12-43  | SPACE               |               | --               | 1                          | --          | --      |          |                         |      |      | 1     | --   |      | SPACE               | F12-44 |
| F12-45  | DPC/EVO600          | N             | 20 A             | 1                          |             |         | 1920     | 192                     |      |      | 1     | 15 A | N    | DISPENSER POWER     | F12-46 |
| F12-47  | SWITCHED NEUTRAL    |               | --               | 1                          |             |         |          |                         | --   | --   | 1     | --   |      | SWITCHED NEUTRAL    | F12-48 |
| F12-49  | SPACE               |               | --               | 1                          | --          | --      |          |                         |      |      | 1     | --   |      | SPACE               | F12-50 |
| F12-51  | MSACCU-1            | N             | 15 A             | 2                          |             |         | 1248     | 180                     |      |      | 1     | 20 A | N    | SYNERGY FSC         | F12-52 |
| F12-53  | --                  |               | --               | --                         |             |         |          |                         | 1248 | 0    | 1     | 20 A | N    | SPARE               | F12-54 |
| F12-55  | Power               | N             | 20 A             | 1                          | 180         | 0       |          |                         |      |      | 1     | 20 A | N    | SPARE               | F12-56 |
| F12-57  | DISPENSER POWER     |               | 20 A             | 1                          |             |         | 192      | 0                       |      |      | 1     | 20 A | N    | SPARE               | F12-58 |
| F12-59  | SWITCHED NEUTRAL    | N             | --               | 1                          |             |         |          |                         | --   | 0    | 1     | 20 A | N    | SPARE               | F12-60 |
| F12-61  | SPACE               |               | --               | 1                          | --          | 0       |          |                         |      |      | 1     | 20 A | N    | SPARE               | F12-62 |
| F12-63  |                     |               |                  |                            |             |         |          |                         |      |      |       |      |      |                     | F12-64 |
| F12-65  |                     |               |                  |                            |             |         |          |                         |      |      |       |      |      |                     | F12-66 |
| F12-67  |                     |               |                  |                            |             |         |          |                         |      |      |       |      |      |                     | F12-68 |
| F12-69  |                     |               |                  |                            |             |         |          |                         |      |      |       |      |      |                     | F12-70 |
| F12-71  |                     |               |                  |                            |             |         |          |                         |      |      |       |      |      |                     | F12-72 |
|   |                     |               |                  |                            | Total Load: | 5316 VA | 19085 VA | 6384 VA                 |      |      |       |      |      |                     |        |
|   |                     |               |                  |                            | Total Amps: | 44 A    | 160 A    | 55 A                    |      |      |       |      |      |                     |        |
| Type Legend:<br>N=NORMAL G=GFI M=MOTORIZED E=EXISTING ST=SHUNT TRIP A=ARC FAULT H=HANDLE LOCK   |                     |               |                  |                            |             |         |          |                         |      |      |       |      |      |                     |        |
| Load Classification   | Connected Load      | Demand Factor | Estimated Demand | Panel Totals               |             |         |          |                         |      |      |       |      |      |                     |        |
| HVAC  | 2496 VA             | 100.00%       | 2496 VA          | Total Conn. Load:          | 30.8 kVA    |         |          |                         |      |      |       |      |      |                     |        |
| Power   | 25328 VA            | 100.00%       | 25328 VA         | Total Est. Demand:         | 30.8 kVA    |         |          |                         |      |      |       |      |      |                     |        |
| Equipment   | 2808 VA             | 100.00%       | 2808 VA          | Total Conn. Current:       | 85 A        |         |          |                         |      |      |       |      |      |                     |        |
| Lighting  | 153 VA              | 125.00%       | 191 VA           | Total Est. Demand Current: | 86 A        |         |          |                         |      |      |       |      |      |                     |        |
| Notes:  |                     |               |                  |                            |             |         |          |                         |      |      |       |      |      |                     |        |



WORKING ON TOMORROW.

800 556-4491  
origindesign.com

origindesign.com  
800 556-4491  
© Origin Design Co.



CITY OF DUBUQUE

FUELING STATION  
IMPROVEMENT PROJECT

Location / Description  
925 KERPER CT.  
DUBUQUE, IA

|           |                |                          |                 |
|-----------|----------------|--------------------------|-----------------|
| Revisions | Rev            | Description              | Date            |
|           | Project Number | Issued For Bidding:      | Project Manager |
|           |                | Issued For Construction: |                 |

MECHANICAL AND  
ELECTRICAL SCHEDULES

ME3.10

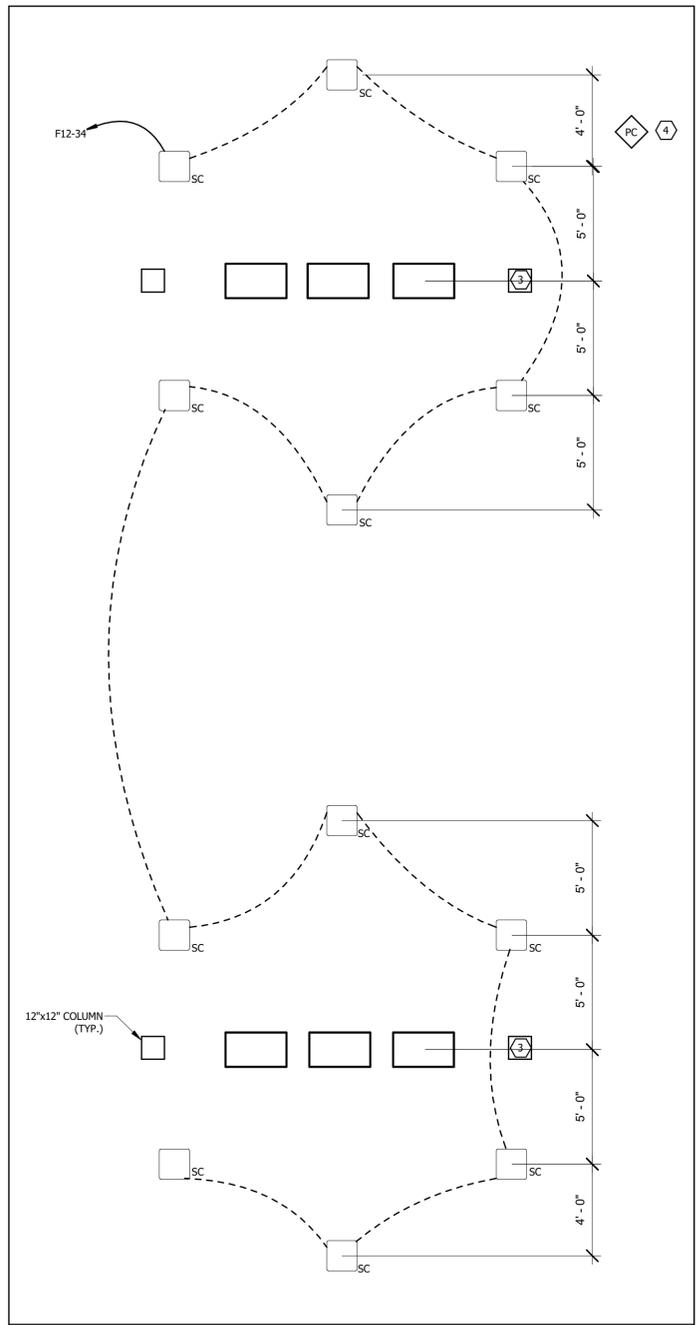

**1** CANOPY LIGHTING PLAN  
1/4" = 1'-0"

**LIGHTING FIXTURE SCHEDULE**

| TYPE | BOD MANUFACTURER | MODEL NUMBER                         | DESCRIPTION  | LAMP/CCT/CRI  | CONTROL | DELIVERED LUMENS | WATTS | VOLTS | EQUALS                   |
|------|------------------|--------------------------------------|--|---------------|---------|------------------|-------|-------|--------------------------|
| SC   | LSI INDUSTRIES   | SCV LED 10L SC UNV DIM 50 XX IMSBT1L | LED PETROLEUM CANOPY LED LUMINAIRE. DIE CAST ALUMINUM CONSTRUCTION WITH FLAT GLASS LENS. WET LOCATION RATED. INTEGRAL 0-10V DIMMABLE DRIVER. ARCHITECT TO SELECT FINISH DURING SUBMITTALS. INTEGRAL WIRELESS MOTION AND PHOTOSENSOR CONTROL. ELECTRICAL CONTRACTOR SHALL ACCOUNT FOR FIXTURE WITH CUSTOM LUMEN PACKAGE FOR PRICING PURPOSES. | LED/5000K/70+ | 0-10V   | 10,317           | 67    | UNV   | ENGINEER APPROVED EQUALS |

LIGHTING FIXTURE SCHEDULE NOTES:  
 1. PROVIDE ALL PARTS AND PIECES FOR A COMPLETE AND FULLY FUNCTIONAL LIGHTING SYSTEM.  
 2. CONTRACTOR SHALL INSTALL ALL FIXTURES PER MANUFACTURER RECOMMENDATIONS IN LOCATIONS SHOWN ON DRAWING AND NOTIFY DESIGN TEAM IF THIS IS NOT POSSIBLE FOR ROUGH IN.  
 3. ARCHITECT SHALL SELECT ALL FINISHES/COLORS AT THE TIME OF SUBMITTAL.  
 4. COORDINATE ALL DRIVERS WITH CONTROLS TO INSURE FULL COMPATIBILITY.  
 LIGHTING FIXTURE SCHEDULE BY: DAVID JORDAN 319-433-1478

**GENERAL NOTES:**

- ALL DISCONNECTS ON MECHANICAL EQUIPMENT SHALL BE MOUNTED ON STRUCTURE TO ALLOW REMOVAL OF THE EQUIPMENT FOR MAINTENANCE WITH A MINIMUM OF WIRING WORK. VERIFY NEC CLEARANCE REQUIREMENTS ARE MET PRIOR TO ROUGH-IN.
- MAINTAIN SERVICE CLEARANCE AROUND ALL MECHANICAL & ELECTRICAL EQUIPMENT. DO NOT ROUTE PIPING OR CONDUIT IN CLEARANCE SPACE.
- ALL RECEPTACLE CIRCUITS SHALL HAVE DEDICATED NEUTRALS.
- PROVIDE PVC SCH 40 CONDUIT WITH RIGID TURN UP WITHIN EQUIPMENT UNLESS OTHERWISE NOTED.
- INSTALL ALL FUEL EQUIPMENT PER MANUFACTURER'S RECOMMENDATIONS AND REQUIREMENTS.
- CONDUIT LAYOUT IS SCHEMATIC IN NATURE, NOT ALL OFFSETS OR SPACING MAY BE SHOWN. CONTRACTOR SHALL SITE VERIFY.
- LOCATE LIGHTING TO BE IN-LINE WITH CANOPY PANELS. CONFIRM WITH DESIGN TEAM.
- PROVIDE ALL LOCAL AND STATE PERMITS AND INSPECTIONS, INCLUDING ALL APPROPRIATE FEES.
- INSTALL UNDERGROUND TANKS WITH A MINIMUM OF 4' COVER.

**REFERENCED NOTES:**

- PROVIDE FIRE EXTINGUISHER AND EXTERIOR RATED CABINET IN ACCORDANCE TO THE STATE FIRE MARSHAL REQUIREMENTS.
- COORDINATE PANEL LOCATIONS WITH DESIGN TEAM.
- 4" PVC SCH 40 ROOF DRAIN WITHIN COLUMN. CONNECT TO UNDER GRADE STORM SEWER. SEE CIVIL PLANS FOR CONTINUATION.
- ELECTRICAL CONTRACTOR SHALL FURNISH AND INSTALL STEM SWIVEL MOUNT PHOTOCELL EQUAL TO #EK4236S TO CONTROL EXTERIOR LIGHTING. COORDINATE FOR NORTH FACING INSTALLATION.
- DC POWER SHALL BE 18 GAUGE 2 CONDUCTOR TWISTED AND SHIELDED WITH DRAIN AND TEFLON COATING. ELECTRICAL CONTRACTOR SHALL FURNISH AND INSTALL ALL DC WIRING SERVING FLOAT SENSORS, SUMP SENSORS, AND PROBES AS REQUIRED FOR A COMPLETE AND WORKING SYSTEM.
- ELECTRICAL CONTRACTOR SHALL FURNISH AND INSTALL BREAKAWAY T-BASE TO SERVE TYPE SA FIXTURE. PROVIDE LIGHT POLE BASE PLATE ADAPTOR TO UTILIZE THE CANOPY COLUMN FOUNDATION FOR LIGHT FIXTURE POLE BASE.
- EMERGENCY PUSH BUTTON SHALL DISCONNECT POWER TO ALL DISPENSING DEVICES; TO ALL REMOTE PUMPS SERVING THE DISPENSING DEVICES; TO ALL ASSOCIATED POWER, CONTROL, AND SIGNAL CIRCUITS; AND TO ALL OTHER ELECTRICAL EQUIPMENT IN THE HAZARDOUS (CLASSIFIED) LOCATIONS SURROUNDING THE FUEL DISPENSING DEVICES. INSTALLATION SHALL BE COMPLIANT WITH NEC SECTION 514.
- ELECTRICAL CONTRACTOR SHALL ROUGH-IN FOR FUEL PUMP EMERGENCY STOP REUSE EXISTING RACEWAY AS NEEDED. REFER TO EMERGENCY FUELING STATION SHUTOFF WITH COVER ON SHEET MEZ.10 FOR MORE INFORMATION
- ELECTRICAL CONTRACTOR SHALL PROVIDE ALL CONDUITS WITH EXPLOSION PROOF SEAL OFFS AS PER NEC REQUIREMENTS. SEE DETAILS ON SHEET MEZ.10 FOR MORE INFORMATION REGARDING SEAL OFF INSTALLATION AND STUB UP SPACING.
- CANOPY STORM DOWNSPOUTS SHALL BE ROUTED FROM THE EASTERN COLUMNS TO THE UNDERGROUND STORM SEWER. REFER TO CIVIL PLANS FOR ADDITIONAL INFORMATION INCLUDING PIPE SIZES AND MATERIAL.
- COORDINATE VARIABLE FREQUENCY CONTROLLERS (VFC) LOCATIONS WITH DESIGN TEAM.
- PROVIDE 72" PEDESTAL (POWDER COATED WHITE) AND INSTALL THE TANK OVERFLOW SHUTOFF/ALARM. PROVIDE PEDESTAL WITH CONCRETE BASE EXTENDING 48" BELOW GRADE AND LOCATE BETWEEN BOLLARDS.
- PROVIDE SINGLE-POINT POWER CONNECTION BETWEEN INDOOR UNIT AND OUTDOOR UNIT. COORDINATE INSTALLATION WITH MECHANICAL CONTRACTOR.



WORKING ON TOMORROW.

800 556-4491  
origindesign.com

origindesign.com  
800 556-4491  
© Origin Design Co.



CITY OF DUBUQUE

FUELING STATION IMPROVEMENT PROJECT

Location / Description  
925 KERPER CT.  
DUBUQUE, IA

| Revisions | Rev | Description     | Date                     |
|-----------|-----|-----------------|--------------------------|
|           |     | Project Number  | Issued For Bidding:      |
|           |     | Project Manager | Issued For Construction: |

CANOPY LIGHTING PLAN