



Version 4.0.1 November 26, 2019

Sigfox RF & Protocol Test Plan for RC2-UDL-ENC-MONARCH

Public Use

Note: Only the last version of this document available on the Sigfox web sites is official and applicable. This document is the property of Sigfox. It shall not be copied and / or disclosed to third parties, in any form without Sigfox written permission.

Contents

| | | |
|----------|--|-----------|
| 1 | Introduction | 2 |
| 1.1 | Acronyms and abbreviations | 2 |
| 2 | Test Setups | 3 |
| 2.1 | TX Test Setup - DBPSK Modulation Quality | 3 |
| 2.2 | TX Test Setup - Demodulated Information | 4 |
| 2.3 | RX Test Setup DOWNLINK | 5 |
| 2.4 | TX/RX Test Setup DOWNLINK | 6 |
| 2.5 | Monarch Test Setup MONARCH | 6 |
| 3 | Tests vs. Specifications | 7 |
| 3.1 | Operational Frequencies | 7 |
| 3.2 | TX RF modulation | 9 |
| 3.3 | TX Baudrate | 11 |
| 3.4 | Output Spectrum | 11 |
| 3.5 | Carrier frequency stability | 12 |
| 3.6 | RX Demodulation | 13 |
| 3.7 | Monarch RC determination | 13 |
| 3.8 | Sigfox Link Budget | 15 |
| 3.9 | Protocol | 15 |
| 3.10 | Timings | 20 |
| 4 | Additional Measurements | 22 |
| 4.1 | Modulated Conducted TX Output power | 22 |
| 4.2 | Validation of the information contained in the OOB Frame | 22 |
| 4.3 | I/Q Wave record | 23 |

1 Introduction

This document describes all the scenarios executed to test a Sigfox *Device* or *Modular Design*.

1.1 Acronyms and abbreviations

- **2GFSK**: 2-Level Gaussian Frequency Shift Keying
- **ACK**: Acknowledgement
- **AES**: Advanced Encryption Standard
- **Att**: Attenuator
- **CAB**: Client Application Board
- **CBC**: Cipher Block Chaining
- **CS**: Carrier Sense
- **Cold Test**: Test executed in initial condition (wait till the DUT come back to the initial system between two tests)
- **DBPSK**: Differential Binary Phase-Shift Keying
- **DUT**: Device Under Test
- **Duty Cycle**: part of a period in which a signal is active (high state/Period)
- **ENC**: Encrypted
- **Fd**: DUT Frequency
- **Fe**: Equipment Frequency
- **Legacy Uplink**: initial payload format of Sigfox Uplink without encryption
- **LBT**: Listen Before Talk
- **NVM**: Non Volatile Memory
- **OOB**: Out Of Band
- **PAC**: Porting Authorization Code
- **PER**: Packet Error Rate
- **PMR**: Private Mobile Radio
- **RC**: Radio Configuration
- **RF**: Radio Frequency
- **RSA**: Radio_Signal_Analyzer
- **RSSI_dut**: DUT RSSI
- **RSSI_eq**: Equipment RSSI
- **SMIQ**: Vector Signal Generator
- **SOC**: System On Chip
- **Sigfox Message**: Three frames with payload 303132333435363738393A3B
- **UNBT**: Ultra Narrow Band Transceiver

2 Test Setups

2.1 TX Test Setup - DBPSK Modulation Quality

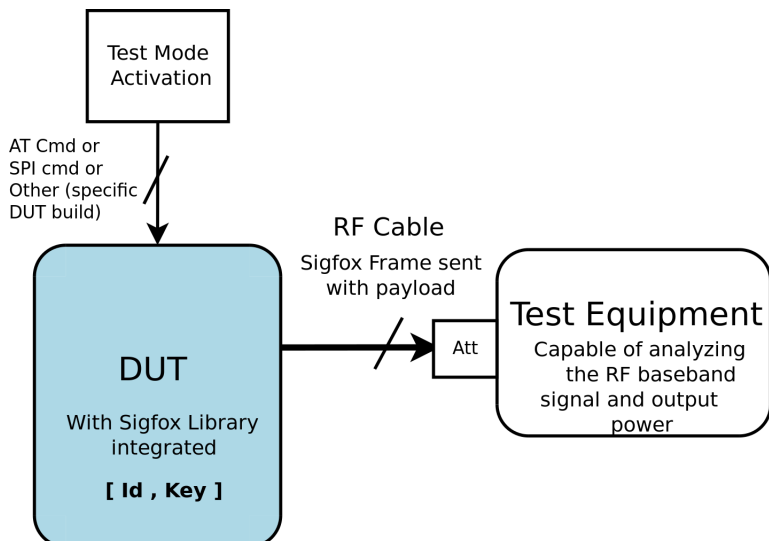

Test Procedure:

- Configure the Test Equipment at 902.2000 MHz
- Calibrate the Test Equipment (considering cable loss)
- Configure DUT to execute the test as explained in the Test Execution part
- Finalize the test verdict depending on the Test Execution

2.2 TX Test Setup - Demodulated Information

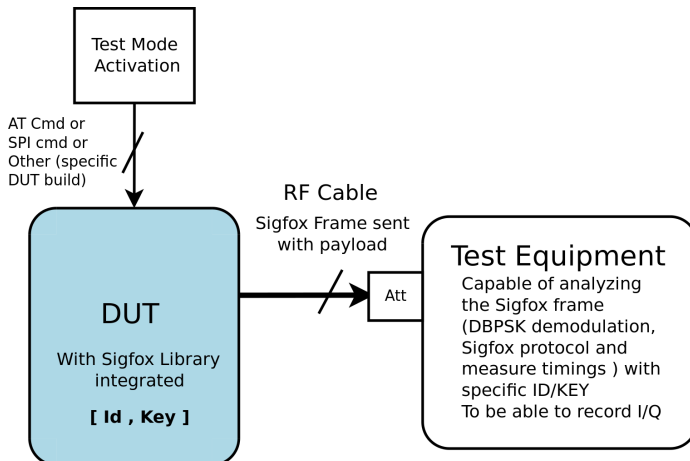

Test Procedure:

- Configure the Test Equipment at 902.2000 MHz with specific ID/KEY (depending on Test Execution)
- Calibrate the Test Equipment (considering cable loss)
- Configure DUT to execute test as explained in the Test Execution part
- Finalize the test verdict depending on the Test Execution

2.3 RX Test Setup **DOWNLINK**

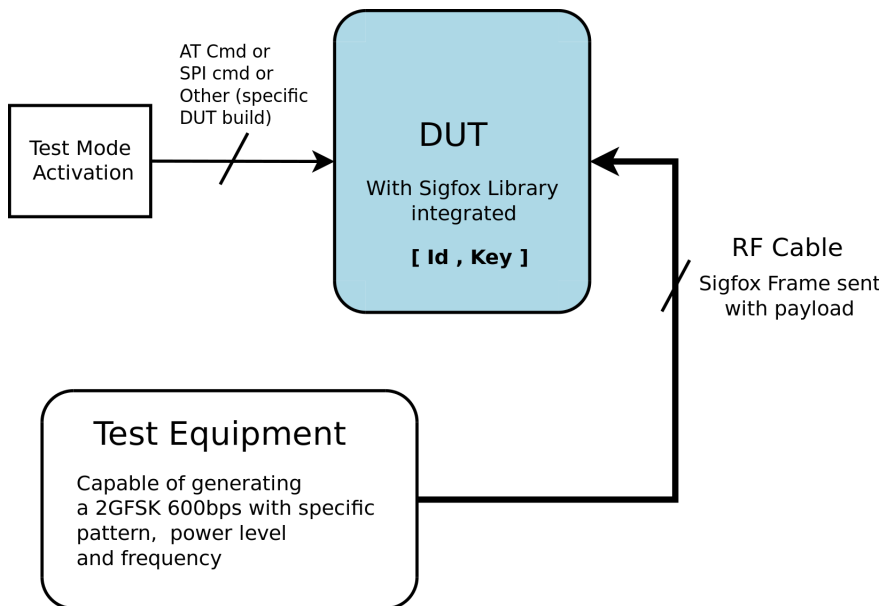

Test Procedure:

- Calibrate the Test Equipment in Power level and Frequency (considering the Cable loss).
- Configure the DUT in RX-GFSK at 905.2000 MHz.
- Choose the level according to the Test Execution
- Send a specific number of 600bps 2GFSK Sigfox pre built frames at a specific power with the pattern (AA AA B2 27 1F 20 41 84 32 68 C5 BA 53 AE 79 E7 F6 DD 9B) at 905.2000 MHz. (Details are described in each Test description)

2.4 TX/RX Test Setup DOWNLINK

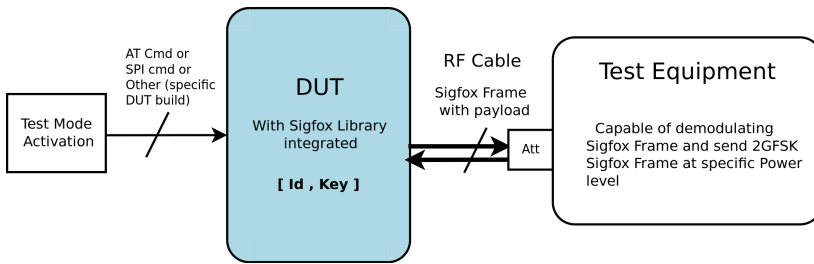

Test Procedure:

- Calibrate the Test equipment in Power level (considering the Cable loss)
- Configure the DUT according to the Test Execution
- Configure the Test Equipment at Frequency 902.2000 MHz
- Demodulate the received data, check the payload and the downlink initiate request. (A)
- Store the timestamp (T1)
- Prepare the 2GFSK frame response (Id, Key, Seq Number)
- Configure the Test Equipment at Frequency 905.2000 MHz to send the response at T1 + Time seconds (Time is specified in the Test Description)
- Check that the DUT received the response and store the timestamp (T2)
- Wait for the Acknowledge response from the DUT (B) and store the timestamp (T3)
- Finalize the test verdict depending on the test execution

2.5 Monarch Test Setup MONARCH

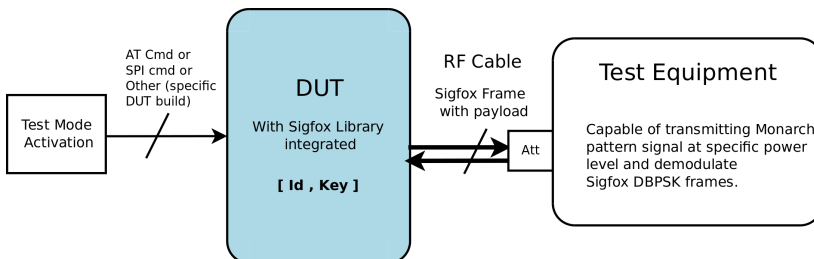

Test Procedure:

- Calibrate the Test equipment in Power level (considering the Cable loss) and Frequency
- Configure the DUT according to the Test Execution
- Configure the Test Equipment at Frequency 905.1800 MHz
- Transmit Monarch Signal as defined in the test execution
- Finalize the test verdict depending on the test execution

3 Tests vs. Specifications

Cold tests have to be done to validate all RF requirements, the goal is to validate the device in worst condition (before established system) . Cold tests will be done only on the Sigfox RF part.

3.1 Operational Frequencies

[PRS-RF-PROTOCOL-10] Frequency Steps

Specification Description: Device or Modular Design synthesized frequency error between two expected frequencies (spaced with a specific delta D) has to be, in absolute value, less than D + 300 Hz.

Test Execution:

- Configure TX Test Setup - DBPSK Modulation Quality - see section 2.1
- Execute the Test Procedure
- Loop on 9 repetitions of the following : Send a Sigfox **Test** Frame of 4 bytes containing the Frequency at which the Test frame is sent. Initial Frequency is the Central Uplink Frequency. Each frame has to be send within a window of 9s and at previous frequency + 100 Hz from the previous frame.
- Get all frequency carriers used and check the delta between channels.
- **Test PASSED if the delta < 300 Hz** Otherwise test is FAILED.

Frequency Step :

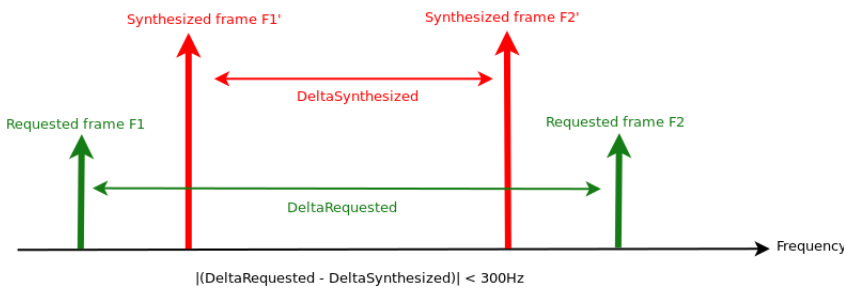

[PRS-RF-PROTOCOL-11] Operational Frequencies Range

Specification Description: Range of frequencies used during transmission has to be between 136800 Hz and 192 kHz.

Test Execution:

- Configure TX Test Setup - Demodulated Information - see section 2.2
 - Execute the Test Procedure
 - Loop on 14 repetitions of the following : Send all types of Sigfox messages with all possible sizes. Each message has to be send following the below procedure :
 - Start a 18s timer.
 - Within the 12s after the start of the timer, send the message.
 - Wait for the end of this 18s before sending a new message.
- Sigfox messages should be in the right order :
- Send bit (0)
 - Send bit (1)
 - OOB frame
 - Send Frame (12 different payload), payload has to be set to 0x40 + byte index.
- Take the minimum and the maximum frequencies
 - Delta is $F_{max} - F_{min}$
 - Test is PASSED if $\Delta \geq 136800$ Hz and $\Delta \leq 192$ kHz . Otherwise test is FAILED.

[PRS-RF-PROTOCOL-12] Operational Frequencies Distribution

Specification Description: The distribution of all frequencies used during transmission has to be uniform.

Test Execution:

- Configure TX Test Setup - Demodulated Information - see section 2.2
 - Execute the Test Procedure
 - Loop on 14 repetitions of the following : Send all types of Sigfox messages with all possible sizes. Each message has to be send following the below procedure :
 - Start a 18s timer.
 - Within the 12s after the start of the timer, send the message.
 - Wait for the end of this 18s before sending a new message.
- Sigfox messages should be in the right order :
- Send bit (0)
 - Send bit (1)
 - OOB frame
 - Send Frame (12 different payload), payload has to be set to 0x40 + byte index.
- Take the minimum (F_{min}) and the maximum (F_{max}) frequencies
 - Divide in ($F_{max} - F_{min} / 6$) part
 - Should have (300 / 6) for each part
 - Apply Pearson's formula, (Khi2 5%)
 - Test is PASSED if the distribution is uniform (Pearson' sum < khi2 5% value). Otherwise test is FAILED.

[PRS-RF-PROTOCOL-13] Static Frequency Tolerance

Specification Description: *Device or Modular Design* carrier frequency (absolute value) must be at +/- 20 ppm for operational bands.

These 20 ppm are managed by the Sigfox system (network + Firmware library) .

One solution is to use a crystal or TCXO with these characteristics:

- Static Frequency Tolerance: precision is not so important if this parameter is calibrated at factory in order to cancel this static imprecision.
- Temperature Frequency tolerance added to Aging frequency tolerance must be less or equal to +/- 20 ppm during all the product life.

All other system can be used if the global imprecision is +/- 20 ppm for operational bands all over the product life.

Test Execution:

- Configure TX Test Setup - DBPSK Modulation Quality - see section 2.1
- Send 3 Sigfox **Test** frames (Uplink request only) with 1s interframe at the Central Uplink Frequency of the RC. The payload is 12 bytes set to 0xAA.
- Get Frequency
- Identify the Static Frequency accuracy.
- Based on this value and the datasheet, compute the global frequency accuracy taking care of aging (on 5 years) and temperature.
- **Test PASSED if $|(Static\ Freq\ accuracy + aging\ (on\ 5\ years) + max\ temperature\ tolerance)| \leq 20\ ppm\ (18044\ Hz)$.** Otherwise test is FAILED.

3.2 TX RF modulation

[PRS-RF-PROTOCOL-20] DBPSK Modulation envelope

Specification Description: *Device or Modular Design* must use DBPSK modulation. Modulation mapping (0: modulate 1: do not modulate)

Test Execution:

- Configure TX Test Setup - DBPSK Modulation Quality - see section 2.1
- Execute the Test Procedure
- Send 3 Sigfox **Test** frames (Uplink request only) with 1s interframe at the Central Uplink Frequency of the RC. The payload is 12 bytes set to 0xAA.
- Display the envelope
- **Test PASSED if the signal is modulated with phase and amplitude level when a 0 occurs.** Otherwise test is FAILED.

[PRS-RF-PROTOCOL-21] Phase Measurement

Specification Description: *Device or Modular Design* DBPSK modulation must be compliant with following performances : Maximum modulation RMS phase error : 10 degree from one symbol to another.
Maximum modulation peak phase error : 30 degree from one symbol to another.

Test Execution: The measurement takes care of the frequency drift.

- Configure TX Test Setup - DBPSK Modulation Quality - see section 2.1
- Execute the Test Procedure
- Send 3 Sigfox **Test** frames (Uplink request only) with 1s interframe at the Central Uplink Frequency of the RC. The payload is 12 bytes set to 0xAA.
- Measure the phase shifting for all block of symbols.
- **Test is PASSED if phase shifting is 10 degree RMS and 30 degree Peak** Otherwise test is FAILED.

[PRS-RF-PROTOCOL-22] Extra symbols before the first Sigfox bit of the frame

Specification Description: Transmission must include an extra symbol timing from 0 to 2 symbols time before the first Sigfox bit. No phase shifting is allowed during this phase except at the symbol time.

- Extra symbols timing before the first Sigfox bit of the frame

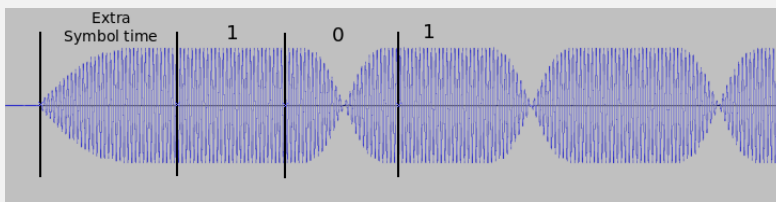

Test Execution:

- Configure TX Test Setup - DBPSK Modulation Quality - see section 2.1
- Execute the Test Procedure
- Send 3 Sigfox **Test** frames (Uplink request only) with 1s interframe at the Central Uplink Frequency of the RC. The payload is 12 bytes set to 0xAA.
- Check the extra symbols timing of all frames
- **Test is PASSED if $0 \text{ symbol time} \leq \text{Extra Symbol Timing in ms} \leq 2 \text{ symbol time}$** . Otherwise test is FAILED.

[PRS-RF-PROTOCOL-23] Extra symbols after the last Sigfox bit of the frame

Specification Description: Transmission must include an extra symbol timing from 0 to 2 symbols time after the transmission of the last Sigfox bit. No phase shifting is allowed during this phase except at the symbol time.

- Extra symbols timing after the last Sigfox bit of the frame

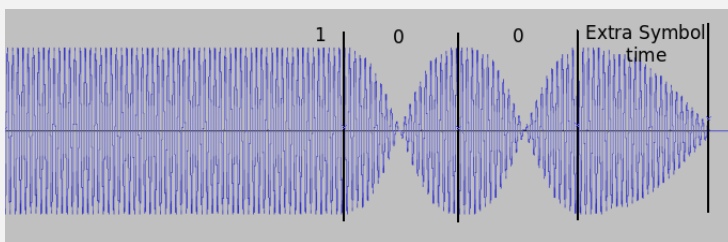

Test Execution:

- Configure TX Test Setup - DBPSK Modulation Quality - see section 2.1
- Execute the Test Procedure
- Send 3 Sigfox **Test** frames (Uplink request only) with 1s interframe at the Central Uplink Frequency of the RC. The payload is 12 bytes set to 0xAA.
- Check the extra symbols timing of all frames
- **Test is PASSED if $0 \text{ symbol time} \leq \text{Extra Symbol Timing in ms} \leq 2 \text{ symbol time}$.** Otherwise test is FAILED.

3.3 TX Baudrate

[PRS-RF-PROTOCOL-30] TX Max Symbol duration

Specification Description: Device or Modular Design must be able to transmit at a baudrate of 600 bps with DBPSK modulation with following tolerances on the symbol duration of +/- 1 %

Test Execution:

- Configure TX Test Setup - DBPSK Modulation Quality - see section 2.1
- Execute the Test Procedure
- Send 3 Sigfox **Test** frames (Uplink request only) with 1s interframe at the Central Uplink Frequency of the RC. The payload is 12 bytes set to 0xAA.
- Compute time between 2 symbols on all frames, and compute the Cumulated Error.
- **Test is PASSED if symbol rate is 600 +/-1 %.** Otherwise test is FAILED.

[PRS-RF-PROTOCOL-31] Max TX Baudrate Cumulated Error

Specification Description: Device or Modular Design must have a maximum baudrate cumulated error of 0.1 % of the whole ideal transmission time. (i.e : for a 26 bytes frame (0.35 s duration), tolerance of 0.35 ms)

Test Execution:

- Configure TX Test Setup - DBPSK Modulation Quality - see section 2.1
- Execute the Test Procedure
- Send 3 Sigfox **Test** frames (Uplink request only) with 1s interframe at the Central Uplink Frequency of the RC. The payload is 12 bytes set to 0xAA.
- Compute time between 2 symbols on all frames, and compute the Cumulated Error.
- **Test is PASSED if Cumulated Error rate is 600 +/-0.1 % .** Otherwise test is FAILED.

3.4 Output Spectrum

[PRS-RF-PROTOCOL-40] Power Spectral Density

Specification Description: *Device or Modular Design* shall respect the following spectrum occupation (averaged power spectral density on associated frequency interval) :

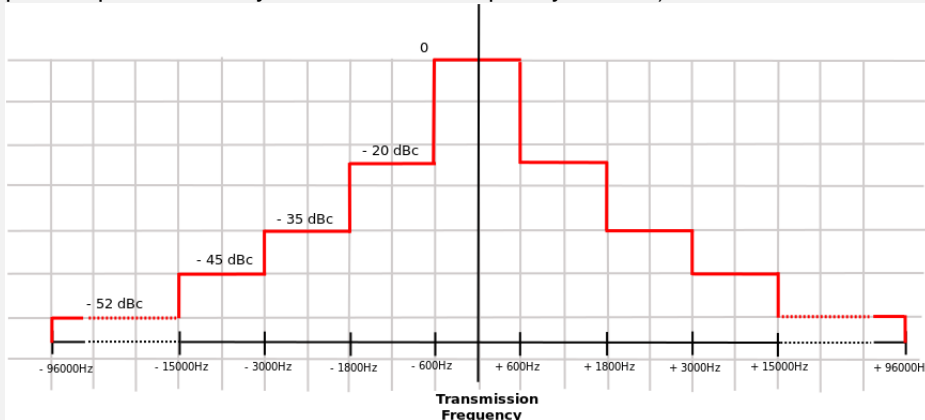

Test Execution:

- Configure TX Test Setup - DBPSK Modulation Quality - see section 2.1
- Execute the test procedure
- Configure the Test Equipment
- Send 3 Sigfox **Test** frames (Uplink request only) with 1s interframe at the Central Uplink Frequency of the RC. The payload is 12 bytes set to 0xAA.
- Export all values
- Calculate the power for each part to compute power spectral density
- Normalize the first part to 0 and all others part according to the first to have dBc values
- **Test is PASSED if the DUT respect the Sigfox spectrum occupation .** Otherwise test is FAILED.

3.5 Carrier frequency stability

[PRS-RF-PROTOCOL-50] Transitional Frequency Dynamic Drift

Specification Description: *Device or Modular Design* carrier frequency must respect a max absolute frequency shifting peak of 100 Hz/s from the first quarter of the synchro bits to the end of the synchro bits.

Test Execution:

- Configure TX Test Setup - DBPSK Modulation Quality - see section 2.1
- Execute the Test Procedure
- Send 3 Sigfox **Test** frames (Uplink request only) with 1s interframe at the Central Uplink Frequency of the RC. The payload is 12 bytes set to 0xAA.
- Check the transitional frequency Drift measurement
- **Test is PASSED if the transitional frequency drift has a max absolute frequency shifting peak of 100 Hz/s .** Otherwise test is FAILED.

[PRS-RF-PROTOCOL-51] Established Frequency Dynamic Drift

Specification Description: *Device or Modular Design* carrier frequency must respect a max absolute frequency shifting of 50 Hz/s from end of synchro bits to the end of a transmission of the maximum Sigfox frame. Method of the least squares will be used for the measurement.



Test Execution:

- Configure TX Test Setup - DBPSK Modulation Quality - see section 2.1
- Execute the Test Procedure
- Send 3 Sigfox **Test** frames (Uplink request only) with 1s interframe at the Central Uplink Frequency of the RC. The payload is 12 bytes set to 0xAA.
- Check the established frequency Drift measurement
- **Test is PASSED if the establish frequency drift has a max absolute frequency shifting of 50 Hz/s .** Otherwise test is FAILED.

3.6 RX Demodulation

[PRS-RF-PROTOCOL-60] 2GFSK 600bps **DOWNLINK**

Specification Description: *Device or Modular Design* must be able to demodulate 2GFSK at 600bps (BT = 1.0, $\Delta f = \pm 800\text{Hz}$).

Test Execution:

- Configure RX Test Setup - see section 2.3
- Execute the Test Procedure (level -100dBm)
- Request for a receive Test Frame at the Downlink Central Frequency with AUTHENTICATION OFF with RX-GFSK static buffer pattern value and 30s listening window duration.
- Check the packet received by the device
- **Test is PASSED if the device receives the frame with specific RX-GFSK Sigfox pattern.** Otherwise test is FAILED.

3.7 Monarch RC determination

[PRS-RF-PROTOCOL-70] Radio Configuration determination from Monarch signal at high power level **MONARCH**

Specification Description: *Device or Modular Design* must be able to identify the RC2 based on Monarch signal when only an RC2 beacon is transmitted at -27dBm (power level of the whole beacon).

Test Execution:

- Configure Monarch Test Setup - see section 2.5
- Execute the Test Procedure
- Loop on 10 repetitions of the following : Send a Sigfox **Test** Frame without downlink request. Execute monarch RC scan with a 4s listening window. Wait for 6 seconds before running the next loop.
- The equipment driven by the device (through a Sigfox frames) sends the beacon RC2 , with a signal at -27 dBm (power level of the whole beacon). The loop is executed 10 times.
- Compute the error rate of the RC2 beacon
- **Test is PASSED if the error rate $\leq 0\%$.** Otherwise test is FAILED.

[PRS-RF-PROTOCOL-71] Link Budget on Monarch signal **MONARCH**

Specification Description: *Device or Modular Design* Monarch Sensitivity should be ≤ -126 dBm with a PER at 10% within a confidence interval greater or equal to 95% when the Modulated Output Power is 22 dBm ERP, to keep the link budget balanced.

If the Modulated Output Power is less than 22 dBm, so all dB lost in Tx will be added at -126 to keep the link budget balanced ± 2 dBm.

At the balanced link budget, the Monarch Rx sensitivity should be : $\text{MonarchRxSensiAtBalancedLinkBudget} = -126 + 22 - \text{TxPower}$

Test Execution:

- Configure Monarch Test Setup - see section 2.5
- Execute the Test Procedure at $\text{MonarchRxSensiAtBalancedLinkBudget}$ (as described above)
- Send a Sigfox **Test** Frame without downlink request. Execute monarch RC scan with a 4s listening window. Wait for 6 seconds before running the next loop.
- The equipment driven by the device (through a Sigfox frames) sends the beacon RC2 , with a signal at $-126 + 22 - \text{TxPower}$ dBm (power level of the whole beacon).
- After each sent frame, count the number of frames received by the DUT and calculate the estimated PER interval for 95% confidence.
- If less than 300 frames were sent and 10% PER is within the estimated PER interval, repeat the procedure, Otherwise check the final verdict condition.
- Test is FAILED if less than 300 frames were sent and 10% PER is below the estimated PER interval for 95% confidence or if other RC has been identified. **Otherwise Test is PASSED**

With the above rules, the verdict can be identified much before the 300 frames sent.

[PRS-RF-PROTOCOL-72] Robustness to High Power Level interferer for Monarch signal **MONARCH**

Specification Description: *Device or Modular Design* must not detect RC2 when only First pattern of RC2 (or Second Pattern of RC2) is sent during 400 ms at -27dBm (power level of the whole beacon).

Test Execution:

- Configure Monarch Test Setup - see section 2.5
- Execute the Test Procedure
- Loop on 10 repetitions of the following : Send a Sigfox **Test** Frame without downlink request. Execute monarch RC scan with a 4s listening window. Wait for 6 seconds before running the next loop.
- The equipment driven by the device (through a Sigfox frames) execute following sequence 5 times:
 - Send First Pattern of RC2 during 400 ms once at -27dBm (power level of the whole beacon).
 - The device must not detect any RC.
 - Send Second Pattern of RC2 during 400 ms once at -27dBm (power level of the whole beacon).
 - The device must not detect any RC, compute the error rate.

Test is PASSED if error rate $\leq 0\%$. (if NO RC has been detected) Otherwise test is FAILED.

[PRS-RF-PROTOCOL-73] Robustness to Low Power Level interferer for Monarch signal **MONARCH**

Specification Description: *Device or Modular Design* must not detect RC2 when only First Pattern of RC2 (or Second Pattern of RC2) is sent during 400 ms at -120dBm.

Test Execution:

- Configure Monarch Test Setup - see section 2.5
- Execute the Test Procedure
- Loop on 10 repetitions of the following : Send a Sigfox **Test** Frame without downlink request. Execute monarch RC scan with a 4s listening window. Wait for 6 seconds before running the next loop.
- The equipment driven by the device (through a Sigfox frames) execute following sequence 5 times:
 - Send First Pattern of RC2 during 400 ms once at -120dBm.
 - The device must not detect any RC
 - Send Second Pattern of RC2 during 400 ms once at -120dBm.
 - The device must not detect any RC, compute the error rate.

Test is PASSED if error rate $\leq 0\%$. (if NO RC has been detected) Otherwise test is FAILED.

3.8 Sigfox Link Budget

[PRS-RF-PROTOCOL-80] Sigfox Link Budget **DOWNLINK**

Specification Description: *Device or Modular Design* link budget should be ≤ -126 dBm with a PER at 10% within a confidence interval greater or equal to 95% when the Modulated Output Power is 22 dBm ERP, to keep the link budget balanced.

If the Modulated Output Power is less than 22 dBm, so all dB lost in Tx will be added at -126 to keep the link budget balanced.

At the balanced link budget, the Rx level should be : $RxLevelAtBalancedLinkBudget = -126 + 22 - TxPower$

Test Execution:

- Configure TX/RX Test Setup - see section 2.4
- Execute the Test Procedure at $RxSensiAtBalancedLinkBudget$ (as described above)
- Send a Sigfox **Test** frame and Request for a Receive **Test** frame on a listening window of 4s. Payload of the Send frame contains counters on Timeout and Successful receptions. Wait for 6s before starting the next loop item.
- After each sent frame, count the number of frames received by the DUT and calculate the estimated PER interval for 95% confidence.
- If less than 300 frames were sent and 10% PER is within the estimated PER interval, repeat the procedure, Otherwise check the final verdict condition.
- Test is FAILED if less than 300 frames were sent and 10% PER is below the estimated PER interval for 95% confidence. **Otherwise Test is PASSED**

With the above rules, the verdict can be identified much before the 300 frames sent.

3.9 Protocol

[PRS-RF-PROTOCOL-90] AES

Specification Description: *Device or Modular Design* must include an AES module with CBC mode with a 16 bytes key (Hardware or Software) for authentication on network. The Init Vector (IV) is set to 0.

Test Execution:

- Configure TX Test Setup - Demodulated Information - see section 2.2
- Execute the Test Procedure
- Send all types of Sigfox messages with all possible sizes. Each message has to be send following the below procedure :
 - Start a 18s timer.
 - Within the 12s after the start of the timer, send the message.
 - Wait for the end of this 18s before sending a new message.
- Sigfox messages should be in the right order :
 - Send bit (0)
 - Send bit (1)
 - OOB frame
 - Send Frame (12 different payload), payload has to be set to 0x40 + byte index.
- Check on the Test Equipment that the same payload is received.
- Test is PASSED if HMAC is OKAY for all frames. Otherwise test is FAILED

[PRS-RF-PROTOCOL-91] NVM Frequency Storage

Specification Description: Device or Modular Design must include a non volatile memory for frequency carrier storage (at least 2 bytes).

Test Execution:

- Configure TX Test Setup - Demodulated Information - see section 2.2
- Execute the Test Procedure
- Send a 2 bytes payload message containing the PN value of the NVM.
- Check on the Test Equipment, the frequency that has been demodulated: Freq1
- Power Down the DUT and execute the test again. Capture the frequency in Freq2
- Test is PASSED if Freq2 different of Freq1 . Otherwise test is FAILED

[PRS-RF-PROTOCOL-92] NVM Sequence Number Storage

Specification Description: Device or Modular Design must include a non volatile memory for a protocol sequence number storage (at least 2 bytes), not readable by application.

Test Execution:

- Configure TX Test Setup - Demodulated Information - see section 2.2
- Execute the Test Procedure
- Send a 2 bytes payload message containing the PN value of the NVM.
- Check on the Test Equipment, the Sequence Number that has been demodulated: Seq1
- Power Down the DUT and execute the test again. Capture the Sequence Number in Seq2
- Test is PASSED if Seq2 = Seq1 + 1 . Otherwise test is FAILED

[PRS-RF-PROTOCOL-93] Public Key switch

Specification Description: Device or Modular Design must allow a way to switch from private to public key. This requirement is not mandatory for Device and DUT containing a Secure Element (SE), but mandatory for Modular Design and development solution.

- KEY = 00112233445566778899AABBCCDDEEFF (KEY[0]=00, KEY[15]=FF)

Test Execution:

- Configure TX Test Setup - Demodulated Information - see section 2.2
- Execute the Test Procedure
- Switch the DUT to Public Key
- Configure the test equipment in public Key
- Switch the device in public key and send a 1 byte Sigfox message with payload 0xAB. Switch the device back to private key.
- Test is PASSED if the device is able to switch to public key and HMAC is OKAY. Otherwise test is FAILED.

[PRS-RF-PROTOCOL-94] Number of frames per message in Uplink mode

Specification Description: In normal operational mode, *Device* or *Modular Design* must send 3 Sigfox RF frames per customer message.

Test Execution:

- Configure TX Test Setup - Demodulated Information - see section 2.2
 - Execute the Test Procedure
 - Send all types of Sigfox messages with all possible sizes. Each message has to be send following the below procedure :
 - Start a 18s timer.
 - Within the 12s after the start of the timer, send the message.
 - Wait for the end of this 18s before sending a new message.
- Sigfox messages should be in the right order :
- Send bit (0)
 - Send bit (1)
 - OOB frame
 - Send Frame (12 different payload), payload has to be set to 0x40 + byte index.
- Get the demodulated data
 - Count the number of frames that have been received for the device (check the ID)
 - Test is PASSED if the number of frames is equal to 3. Otherwise test is FAILED

[PRS-RF-PROTOCOL-95] Legacy Uplink

Specification Description: *Device* or *Modular Design* has to be able to send Sigfox Frame through the Sigfox Test Mode function.

Test Execution:

- Configure TX Test Setup - Demodulated Information - see section 2.2
 - Execute the Test Procedure
 - Send all types of Sigfox messages with all possible sizes. Each message has to be send following the below procedure :
 - Start a 18s timer.
 - Within the 12s after the start of the timer, send the message.
 - Wait for the end of this 18s before sending a new message.
- Sigfox messages should be in the right order :
- Send bit (0)
 - Send bit (1)
 - OOB frame
 - Send Frame (12 different payload), payload has to be set to 0x40 + byte index.
- Check on the Test Equipment all demodulated data
 - Test is PASSED if all payload sizes have been received. Otherwise test is FAILED

[PRS-RF-PROTOCOL-96] Uplink Encrypted payload

Specification Description: *Device or Modular Design* has to be able to send Sigfox encrypted Frames through the Sigfox Test Mode function.

Test Execution:

- Configure TX Test Setup - Demodulated Information - see section 2.2
 - Execute the Test Procedure
 - Use the device in encrypted payload mode
 - Send all types of Sigfox messages with all possible sizes. Each message has to be send following the below procedure :
 - Start a 18s timer.
 - Within the 12s after the start of the timer, send the message.
 - Wait for the end of this 18s before sending a new message.
- Sigfox messages should be in the right order :
- Send bit (0)
 - Send bit (1)
 - OOB frame
 - Send Frame (12 different payload), payload has to be set to 0x40 + byte index.
- Check on the Test Equipment all demodulated data
 - Test is PASSED if all payload encrypted sizes have been received . Otherwise test is FAILED

[PRS-RF-PROTOCOL-97] Downlink Legacy **DOWNLINK**

Specification Description: *Device or Modular Design* has to be able to receive Sigfox Frames through the Sigfox Test Mode function and to report if a frame has been received properly or not.

Test Execution:

- Configure TX/RX Test Setup - see section 2.4
- Execute the Test Procedure
- Send a Sigfox message of 12 bytes length with payload set to 0x40 + byte index, and downlink request. Check the response payload (has to be all bytes set with 0x30 + byte index). Send a 1 byte **Test** frame without downlink, with 0x01 if the downlink response was correct and 0x00 otherwise.
- **Test is PASSED if the device receives frame with specific Sigfox GFSK pattern.** Otherwise test is FAILED

[PRS-RF-PROTOCOL-98] Downlink Encrypted Payload **DOWNLINK**

Specification Description: *Device or Modular Design* has to be able to receive Sigfox encrypted Frames.

Test Execution:

- Configure TX/RX Test Setup - see section 2.4
- Execute the Test Procedure
- Use the device in encrypted payload mode
- Send a Sigfox message of 12 bytes length with payload set to 0x40 + byte index, and downlink request. Check the response payload (has to be all bytes set with 0x30 + byte index). Send a 1 byte **Test** frame without downlink, with 0x01 if the downlink response was correct and 0x00 otherwise.
- **Test is PASSED if the device received encrypted frame** Otherwise test is FAILED

[PRS-RF-PROTOCOL-99] RSSI level **DOWNLINK**

Specification Description: At a specific Downlink Frame level, the OOB shall return the same level of RSSI of the received GFSK (+/-2dB).

Test Execution:

- Configure TX/RX Test Setup - see section 2.4
- Send a Sigfox message of 12 bytes length with payload set to 0x40 + byte index, and downlink request. Check the response payload (has to be all bytes set with 0x30 + byte index). Send a 1 byte **Test** frame without downlink, with 0x01 if the downlink response was correct and 0x00 otherwise.
- Execute the Test Procedure with RSSI level set at -80 and store RSSI level from the Device.
- Run again the test Procedure with RSSI level set at -100 and store RSSI level from the Device.
- **Test is PASSED if DUT RSSI (returned through the OOB frame) is +/-2dB GFSK RSSI level sent** otherwise test is failed

[PRS-RF-PROTOCOL-100] Number of Uplink frame in bi-directional mode **DOWNLINK**

Specification Description: *Device or Modular Design* must send 3 Sigfox RF frames per customer message for a message requesting a downlink response.

Test Execution:

- Configure TX/RX Test Setup - see section 2.4
- Execute the Test Procedure
- Send a Sigfox message of 12 bytes length with payload set to 0x40 + byte index, and downlink request. Check the response payload (has to be all bytes set with 0x30 + byte index). Send a 1 byte **Test** frame without downlink, with 0x01 if the downlink response was correct and 0x00 otherwise.
- Count the number of frames that have been received for the device (check the ID)
- **Test is PASSED if the number of frames is equal 3 .** Otherwise test is FAILED

3.10 Timings

[PRS-RF-PROTOCOL-110] TX Interframe Timing in Uplink mode

Specification Description: In normal operational mode, the TX interframe duration in Uplink mode has to be between 500 ms and 525 ms.

Test Execution:

- Configure TX Test Setup - Demodulated Information - see section 2.2
 - Execute the Test Procedure
 - Send all types of Sigfox messages with all possible sizes. Each message has to be send following the below procedure :
 - Start a 18s timer.
 - Within the 12s after the start of the timer, send the message.
 - Wait for the end of this 18s before sending a new message.
- Sigfox messages should be in the right order :
- Send bit (0)
 - Send bit (1)
 - OOB frame
 - Send Frame (12 different payload), payload has to be set to 0x40 + byte index.
- Store the timestamp of each frame (There should be 3 frames per message)
 - Compute delay with frame duration
 - **Test is PASSED if $500\text{ ms} \leq \text{delay} \leq 525\text{ ms}$.** Otherwise test is FAILED

[PRS-RF-PROTOCOL-111] TX Interframe Timing in Bi-directional mode **DOWNLINK**

Specification Description: In normal operational mode, the TX interframe duration in Uplink/Downlink mode has to be between 500 ms and 525 ms, in case of frame repetition (tx_repeat parameter greather than 0). .

Test Execution:

- Configure TX/RX Test Setup - see section 2.4
- Send a Sigfox message of 12 bytes length with payload set to 0x40 + byte index, and downlink request. Check the response payload (has to be all bytes set with 0x30 + byte index). Send a 1 byte **Test** frame without downlink, with 0x01 if the downlink response was correct and 0x00 otherwise.
- Store the timestamp of each frame (There should be 3 frames per message)
- Compute delay with frame duration
- **Test is PASSED if $500\text{ ms} \leq \text{delay} \leq 525\text{ ms}$.** Otherwise test is FAILED

[PRS-RF-PROTOCOL-112] RX Start Of Listening **DOWNLINK**

Specification Description: Device or Modular Design must be able to receive a Downlink frame sent 20.1 s after the first frame (This timing take into account the extra symbol time and the downlink frame duration), following the implementation described in the graph:

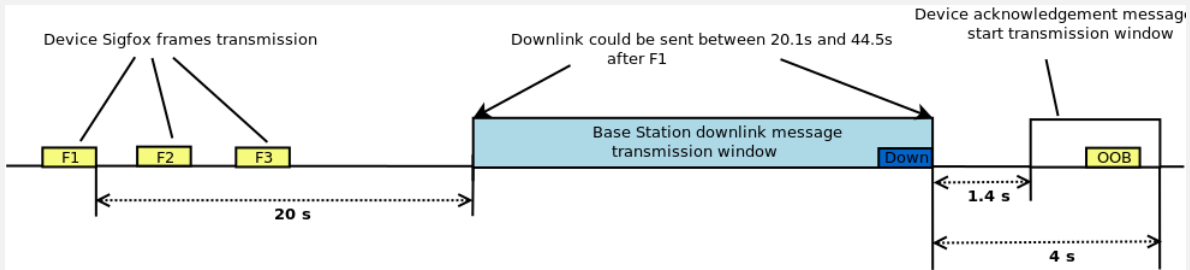

Figure 1: Downlink Timings

Test Execution:

- Configure TX/RX Test Setup - see section 2.4
- Send a Sigfox message of 12 bytes length with payload set to 0x40 + byte index, and downlink request. Check the response payload (has to be all bytes set with 0x30 + byte index). Send a 1 byte **Test** frame without downlink, with 0x01 if the downlink response was correct and 0x00 otherwise.
- **Test is PASSED if the OOB has been received with the right payload and the test frame with 0x01.** Otherwise test is FAILED

[PRS-RF-PROTOCOL-113] RX End Of Listening **DOWNLINK**

Specification Description: The Device or Modular Design must be able to receive a Downlink frame sent 44.5s after the first frame (This timing take into account the extra symbol time and the downlink frame duration), following the implementation described in the graph:

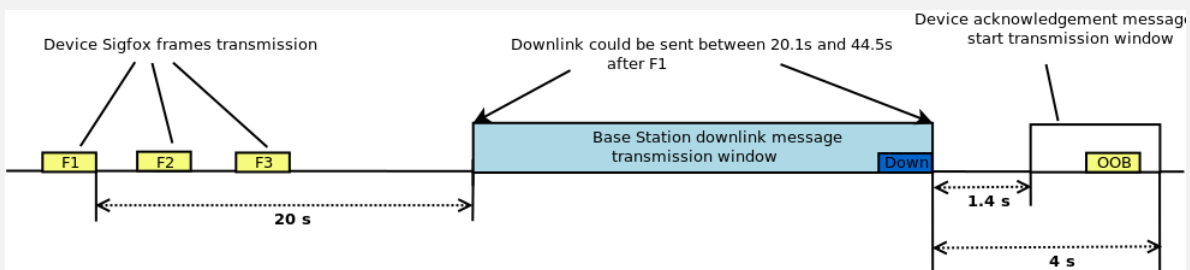

Figure 2: Downlink Timings (last chance to receive downlink frame case)

Test Execution:

- Configure TX/RX Test Setup - see section 2.4
- Execute the test procedure with Time = 44.5 s,
- Send a Sigfox message of 12 bytes length with payload set to 0x40 + byte index, and downlink request. Check the response payload (has to be all bytes set with 0x30 + byte index). Send a 1 byte **Test** frame without downlink, with 0x01 if the downlink response was correct and 0x00 otherwise.
- **Test is PASSED if the OOB has been received with the right payload and the test frame with 0x01.** Otherwise test is FAILED

[PRS-RF-PROTOCOL-114] RX to OOB(ack) Timing DOWNLINK

Specification Description: After receiving the downlink frame, *Device* or *Modular Design* has to wait 1.4 s and no later than 4 s before sending the acknowledgement frame (OOB), following the implementation described in the figure 2.

Test Execution:

- Configure TX/RX Test Setup - see section 2.4
- Execute the Test Procedure with Time = 20.1 s + 17s,
- Send a Sigfox message of 12 bytes length with payload set to 0x40 + byte index, and downlink request. Check the response payload (has to be all bytes set with 0x30 + byte index). Send a 1 byte **Test** frame without downlink, with 0x01 if the downlink response was correct and 0x00 otherwise.
- Compute delay = T3-T2
- **Test is PASSED if $1.4\text{ s} \leq \text{delay} \leq 4\text{ s}$.** Otherwise test is FAILED

4 Additional Measurements

4.1 Modulated Conducted TX Output power

[PRS-RF-PROTOCOL-120] Modulated Conducted Output Power

Measurement: To be able to benefit from optimal Quality of Service with a balanced link budget, Sigfox recommends to respect the following maximum output radiated power : 22dBm ERP(or 24dBm EIRP).

Test Execution:

- Configure TX Test Setup - DBPSK Modulation Quality - see section 2.1
- Send 3 Sigfox **Test** frames (Uplink request only) with 1s interframe at the Central Uplink Frequency of the RC. The payload is 12 bytes set to 0xAA.
- **Give the value of the Modulated Conducted Output Power measured**

4.2 Validation of the information contained in the OOB Frame

[PRS-RF-PROTOCOL-130] DUT Temperature level

Measurement: The OOB shall return the level of Temperature at which the test is executed or 0 is the device is not able to return it.

Test Execution:

- Configure TX Test Setup - Demodulated Information - see section 2.2
- Send all types of Sigfox messages with all possible sizes. Each message has to be send following the below procedure :
 - Start a 18s timer.
 - Within the 12s after the start of the timer, send the message.
 - Wait for the end of this 18s before sending a new message.

Sigfox messages should be in the right order :

- Send bit (0)
 - Send bit (1)
 - OOB frame
 - Send Frame (12 different payload), payload has to be set to 0x40 + byte index.
- Demodulate all frames
 - Give the temperature value (returned through OOB frame)

[PRS-RF-PROTOCOL-131] DUT Voltage level

Measurement: The OOB shall return the level of Voltage at which the test is executed or 0 is the device is not able to return it.

Test Execution:

- Configure TX Test Setup - Demodulated Information - see section 2.2
- Send all types of Sigfox messages with all possible sizes. Each message has to be send following the below procedure :
 - Start a 18s timer.
 - Within the 12s after the start of the timer, send the message.
 - Wait for the end of this 18s before sending a new message.

Sigfox messages should be in the right order :

- Send bit (0)
 - Send bit (1)
 - OOB frame
 - Send Frame (12 different payload), payload has to be set to 0x40 + byte index.
- Demodulate all frames
 - Give the voltage value (returned through OOB frame)

4.3 I/Q Wave record

[PRS-RF-PROTOCOL-140] I/Q Wave record

Measurement: Test Mode TX-BPSK shall be recorded with a 20dB minimum SNR in .raw format.

Test Execution:

- Configure TX Test Setup - DBPSK Modulation Quality - see section 2.1
- Execute the Test Procedure
- Send 3 Sigfox **Test** frames (Uplink request only) with 1s interframe at the Central Uplink Frequency of the RC. The payload is 12 bytes set to 0xAA.
- Record the wave with specific SNR (expected minimum 20dB)