

allocortech inc.

Comet FTS Physical ICD

601-0049-000

Revision C

November 2020

PRELIMINARY



5391 Three Notch'd Rd.
Crozet, VA 22903



<https://allocor.tech>



Table of Contents

| | |
|---|-----------|
| Table of Contents | 2 |
| Version History | 3 |
| Introduction | 4 |
| Scope of this Document | 4 |
| List of Abbreviations | 4 |
| References | 4 |
| Electrical Interface | 5 |
| Connector Pinouts | 5 |
| J1 - Primary Connector | 5 |
| J2 - RF Coax | 6 |
| Chassis Bonding | 6 |
| JTAG Interface | 6 |
| “Harness Eliminator” Debug Interface | 7 |
| Functional Interface | 7 |
| Power Topology | 7 |
| Bootloader | 7 |
| Ethernet | 8 |
| Electrical Ratings | 8 |
| Antenna and Radio Module Information | 9 |
| Overview and Safety | 9 |
| FTS-AIR Antenna | 9 |
| FTS-GND Antenna | 9 |
| Alternative Radio Modules / Frequencies | 10 |
| Mechanical Interface | 11 |
| FTS-AIR Dimensions | 11 |
| FTS-GND Dimensions | 12 |



Version History

| Revision | Changes |
|----------|--|
| A | Initial Draft |
| B | Clarified low end operating voltage, added information about connector mate, and added information about alternative radios. |
| C | Added final unit weights. |



Introduction

The allocortech inc. Comet is a Flight Termination System which is composed of an airborne unit, and up to two Ground units. The system is designed to prevent single faults from causing an uncommanded termination, but is not designed to guarantee a commanded termination in the face of a single fault.

The Comet Air unit can be factory configured with any combination of voted or non voted voltage or current termination outputs. In current mode, the Comet is able to fire up to a 5A pyrotechnic charge.

Optional communication with either ground or air equipment for telemetry and redundant termination commands can happen either through CAN or 10/100 ethernet.

Scope of this Document

This document covers the mechanical and electrical specifications of the allocortech inc. Comet Flight Termination System. As the Flight Termination System is composed of an airborne-unit and a ground-unit which are connected via RF link, both are discussed in this document, with distinctions being made where appropriate.

List of Abbreviations

| | |
|---------|---|
| FTS | Flight Termination System |
| FTS-AIR | Flight Termination System - Airborne Unit |
| FTS-GND | Flight Termination System - Ground Unit |

References

DO-160G: Environmental Conditions and Test Procedures for Airborne Equipment

STMicroelectronics AN3155 USART protocol used in the STM32 bootloader



Theory of Operation

Comet consists internally of a common PCB shared between the Air and Ground units, and an additional indicator PCB for the Ground unit. The common PCB hosts two independent termination lanes (consisting of a microprocessor, arm, terminate, and safety switches) with power regulation and holdup being shared between the two lanes.

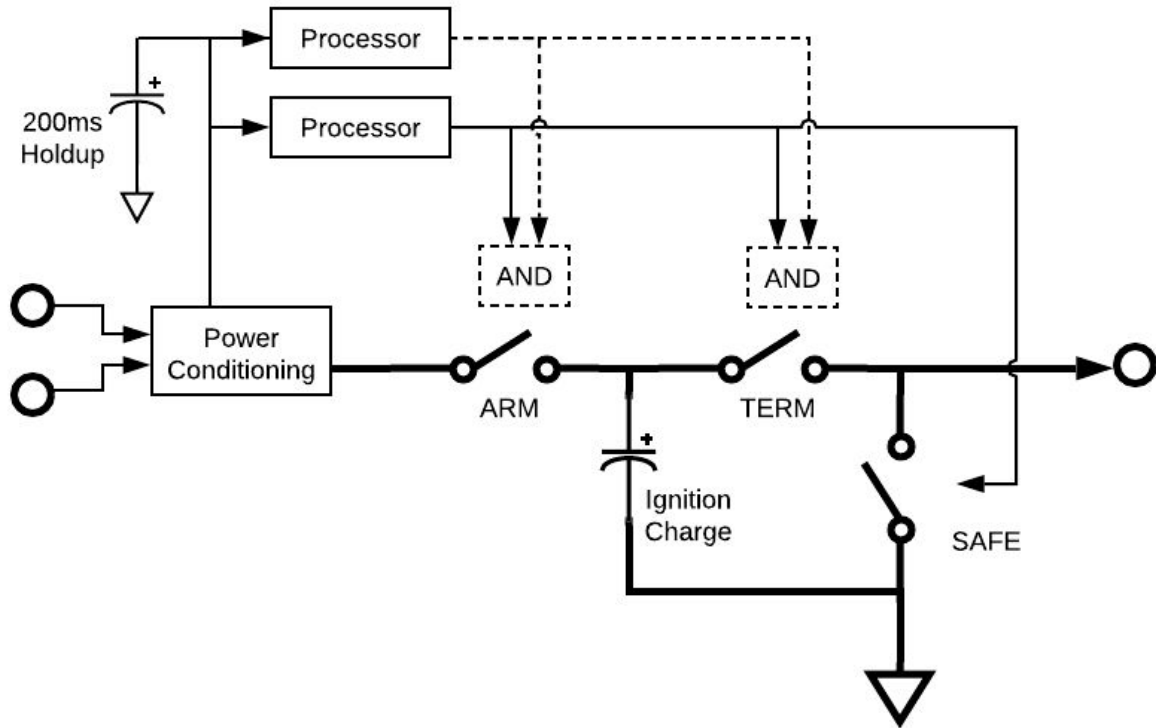

Normally a single processor controls a single termination output, however, as a factory option a logical AND can be added such that each termination output is voted upon by both processors.

Once the Air unit has received a valid termination command from the Ground unit, it will open the SAFE switch, close the ARM switch, allow the ignition charge capacitor to charge, and then close the TERM switch.



Electrical Interface

Connector Pinouts



J1 - Primary Connector

| | |
|--|---|
| | <p>Face view of receptacle TE/DEUTSCH 732-8254-22. This connector is present on both the FTS-AIR and FTS-GND enclosures.</p> <p>20x size 22 male pins, 5A each.</p> <p>Recommended mate: Shell: EN4165M61AN Insert: EN4165A20-222NF</p> |
|--|---|

| Pin | Name | FTS AIR | FTS GND | Notes |
|-----|--------------|----------------|--------------------|---|
| 1 | FTSA+ | Terminate A(+) | <unused> | |
| 2 | FTSB+ | Terminate B(+) | <unused> | |
| 3 | MCU Recovery | | | See Bootloader section |
| 4 | Vin0 + | Power Bus A(+) | Battery Charger(+) | |
| 5 | Vin1 + | Power Bus B(+) | Shore Power(+) | |
| 6 | FTSA- | Terminate A(-) | <unused> | Ground return for Terminate A(+) output |
| 7 | FTSB- | Terminate B(-) | <unused> | Ground return for Terminate B(+) output |
| 8 | MCU Select | | | See Bootloader section |
| 9 | Vin0 - | Power Bus A(-) | Battery Charger(-) | Ground return for Vin0 + |
| 10 | Vin1 - | Power Bus B(-) | Shore Power (-) | Ground return for Vin1+ |
| 11 | EthA TX- | | | |
| 12 | EthA TX+ | | | |
| 13 | Serial RX | | | See Bootloader section |
| 14 | EthB RX- | | | |
| 15 | EthB RX+ | | | |
| 16 | EthA RX+ | | | |
| 17 | EthA RX- | | | |
| 18 | Serial TX | | | See Bootloader section |
| 19 | EthB TX+ | | | |
| 20 | EthB TX- | | | |



J2 - RF Coax

| FTS-AIR | FTS-GND |
|---|--|
|  |  |
| BNC | RP-SMA |

The FTS-AIR and FTS-GND units have a radio module inside. The radio module operates at a nominal frequency of 900Mhz with a transmit power of 1 Watt.

Chassis Bonding

An M3 bonding stud is provided for the FTS-AIR enclosure, to bring the enclosure potential to that of the airframe. Electrical ground inside the enclosure (referenced to power input ground) is connected to chassis with a 4.7M Ω resistor in parallel with a 3,300pF capacitor. The FTS-AIR electronics are designed to withstand 500V of chassis potential relative to power input ground.

The FTS-GND enclosure is connected to input power ground, which is normally the internal battery. External shore power input ground is tied to battery ground internally.

JTAG Interface

Each MCU has a 14-pin JTAG interface accessible inside the enclosure, which matches the ST-Link v3 14-pin debugger interface. P2 connects to MCU A, and P3 connects to MCU B.

| Pin | Name | Pin | Name |
|-----|--------------------|-----|--------------------|
| 1 | N/C | 2 | N/C |
| 3 | +3.3V | 4 | JTMS |
| 5 | GND | 6 | JTCK |
| 7 | GND | 8 | JTDO |
| 9 | N/C | 10 | JTDI |
| 11 | GND | 12 | nRST |
| 13 | 3.3V TTL USART3 RX | 14 | 3.3V TTL USART3 TX |



“Harness Eliminator” Debug Interface

An additional debug connector P4 is provided on the PCB, with the following pinout:

| Pin | Name | Pin | Name |
|-----|-----------------|-----|-----------------|
| 1 | Vin (*) | 2 | Vin (*) |
| 3 | GND | 4 | GND |
| 5 | MCU B nRST (**) | 6 | MCU A nRST (**) |
| 7 | MCU Recovery & | 8 | GND |
| 9 | MCU Select & | 10 | GND |

(*) Vin is tied directly into the Comet power supply circuitry, bypassing fusing and overvoltage protection. Voltage supplied at this port must be limited to 30V maximum or else damage may result. It is recommended to externally limit current to 500mA.

(**) MCU [A/B] nRST lines provide direct connection to CPU nRESET lines. Connect either pin to GND to reset the corresponding MCU.

& MCU Recovery and MCU Select lines operate as described in the Bootloader section of this document.

Functional Interface

Power Topology

FTS-AIR: Both power inputs (Vin0 and Vin1) are OR'd together to power the system. Either power input may fail and the FTS-AIR will remain powered and functional.

FTS-GND: The FTS-GND unit is powered by an internal, rechargeable LiPo battery. Vin0 is the connection to charge the battery via a dedicated battery-charger adapter. Vin1 is for optional Shore-Power. Note that the internal battery and Shore Power are OR'd together to power the system, meaning that Shore Power input voltage must be higher than that of the battery for FTS-GND to operate using Shore Power vs using energy from the battery.

Bootloader

Both FTS-AIR and FTS-GND provide external bootloader capability. The serial lines (RX and TX) accept RS232 level signals (approximately -5V to +5V). To initiate the bootloader sequence, perform the following steps:

- 1) With the unit powered off, hold the “MCU Recovery” line to power input ground
- 2) Ground the “MCU Select” line to power input ground to enter the bootloader for Lane A. Leave “MCU Select” floating to select Lane B.
- 3) Power the unit on, and begin the bootloader sequence defined in AN3155.



Ethernet

Each MCU lane provides an IEEE 802.3u 10/100 Auto MDI-X Ethernet port.

Electrical Ratings

| | Spec | Min | Nom | Max | Units |
|---|----------------------------|--|-------------|------------|-------------|
| Voltage Input FTS-AIR: Vin0, Vin1 FTS-GND: Vin1 | DO160G 16.6.1.1 (Cat B) | 18.0 (*) | 28.0 | 30.3 (**) | V |
| FTS-GND Vin0 | Use Supplied Charger | | | | |
| Power Draw Vin0, Vin1 | | | 5 | 10 | W |
| Terminate (A/B) | | Terminate outputs follow MAX(Vin0, Vin1) 100mA max per output | | | V |
| Serial TX High Level Low Level | RS232 | 5.0 | 5.4 -5.4 | -5.0 | V V |
| Serial RX High threshold Low threshold Operating limit | RS232 | 0.8 -25 | 1.8 1.5 | 2.4 +25 | V V V |
| Ethernet (A/B) | IEEE 803.2u | | | | |
| MCU Recovery | 3.3V TTL | 0 | | 3.3 | V |
| MCU Select | 3.3V TTL | 0 | | 3.3 | V |
| RF Output | | | | 1 | W |

(*) Error free operation down to 16V anticipated by component specification, holdup time of 50ms only guaranteed when starting from 28V

(**) Surge to 60V per DO160G 16.6.2.4



Antenna and Radio Module Information

Overview and Safety

The radio module used in this product complies with Part 15 of the FCC rules. Operation is subject to the following two conditions: (1) this device may not cause harmful interference, and (2) this device must accept any interference received including interference that may cause undesired operation.

FCC ID: NS913P900

Industry Canada ID: 3143A-13P900

To satisfy FCC RF exposure requirements for mobile transmitting devices, a separation distance of 23cm or more should be maintained between the antenna of this device and persons during device operation. To ensure compliance, operation at closer than this distance is not recommended.

The FTS-AIR and FTS-GND antennas should be kept as far as practical from any other antenna (including another FTS unit antenna), with a minimum of 2 feet of separation.

FCC Regulations allow up to 36dBm Effective Isotropic Radiated Power (EIRP). Therefore, the sum of the transmitted power (in dBm), the cabling loss and the antenna gain cannot exceed 36dBm. The transmit power of the FTS is set to 30dBm by default but is software customizable.

FTS-AIR Antenna

The following antennas are suggested for application for the FTS-AIR application in the aircraft:

- 1) Dayton-Granger L10-793
- 2) Haigh-Farr 6108

The FTS-AIR antenna requires a $\frac{1}{4}$ wavelength ground-plane (at 900MHz) that is electrically isolated from the airframe. This is a 8cm radius circle minimum.

FTS-GND Antenna

For handheld use of the FTS-GND unit, a 900MHz monopole RP-SMA antenna (eg “rubber duck”) is recommended. Alternatively, for stationary use, connecting a low-loss coax feed-line to a fixed antenna may be desirable, as long as all precautions and limitations outlined in this section are observed.



Alternative Radio Modules / Frequencies

Comet utilizes a socketed Microhard Systems Pico series radio. With no hardware effort, any Pico series radio is compatible with the power delivery and connector system used inside the Comet. Additional frequency bands available are:

| Band | Operating Mode | Maximum Power | Approvals |
|---------------------|--------------------------------------|----------------------|-------------------------------------|
| 400MHz | Fixed Frequency | 2W | License Required |
| 840 - 845 MHz | Fixed Frequency | 2W | License Required |
| | Frequency Hopping | 1W | No data |
| 865 - 867 MHz | Frequency Hopping | 1W | Pending |
| 869.25 - 869.75 MHz | Frequency Hopping or Fixed Frequency | 500mW | CE Approval Pending |
| 902-928 MHz | Frequency Hopping | 1W | FCC, Industry Canada, Anatel |
| 2.400 to 2.4835 GHz | Frequency Hopping | 2W | FCC, Industry Canada, CE, Japan Mic |

On request, allocortech will consider making adapter boards for alternative radios and frequencies.



Mechanical Interface

FTS-AIR Dimensions

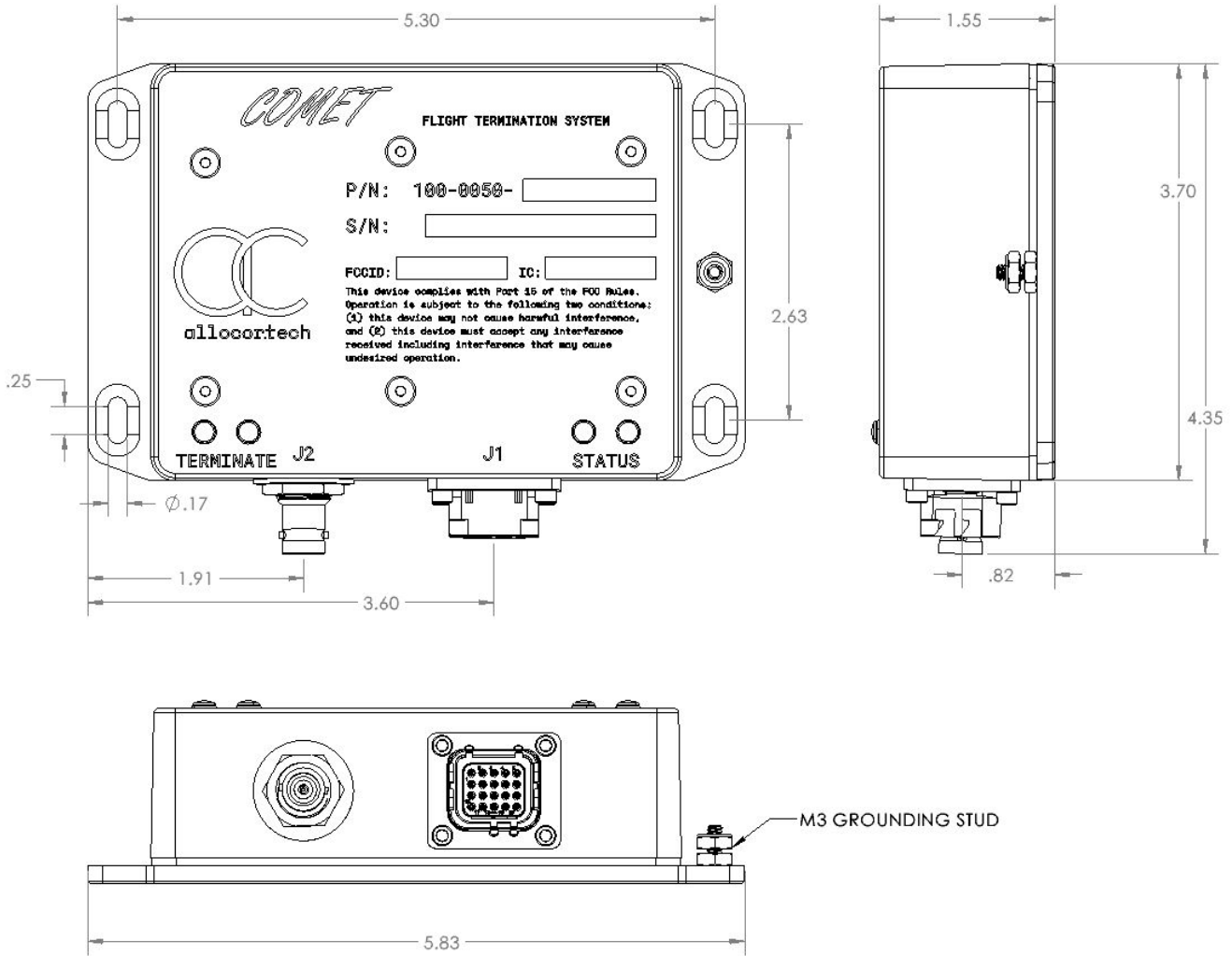

Measurements given in inches.

Attachment: 6-32 x 0.5-in screws on 2.63" x 5.30" square pattern.

Materials: Aluminum Alloy

Finish, Base: Unfinished cast aluminum (chromate conversion on request)

Finish, Enclosure: Powder Coat, Blue Purple (Flip Flop), Powder Buy the Pound SK19811

Weight: 375g (box only no antenna)



FTS-GND Dimensions

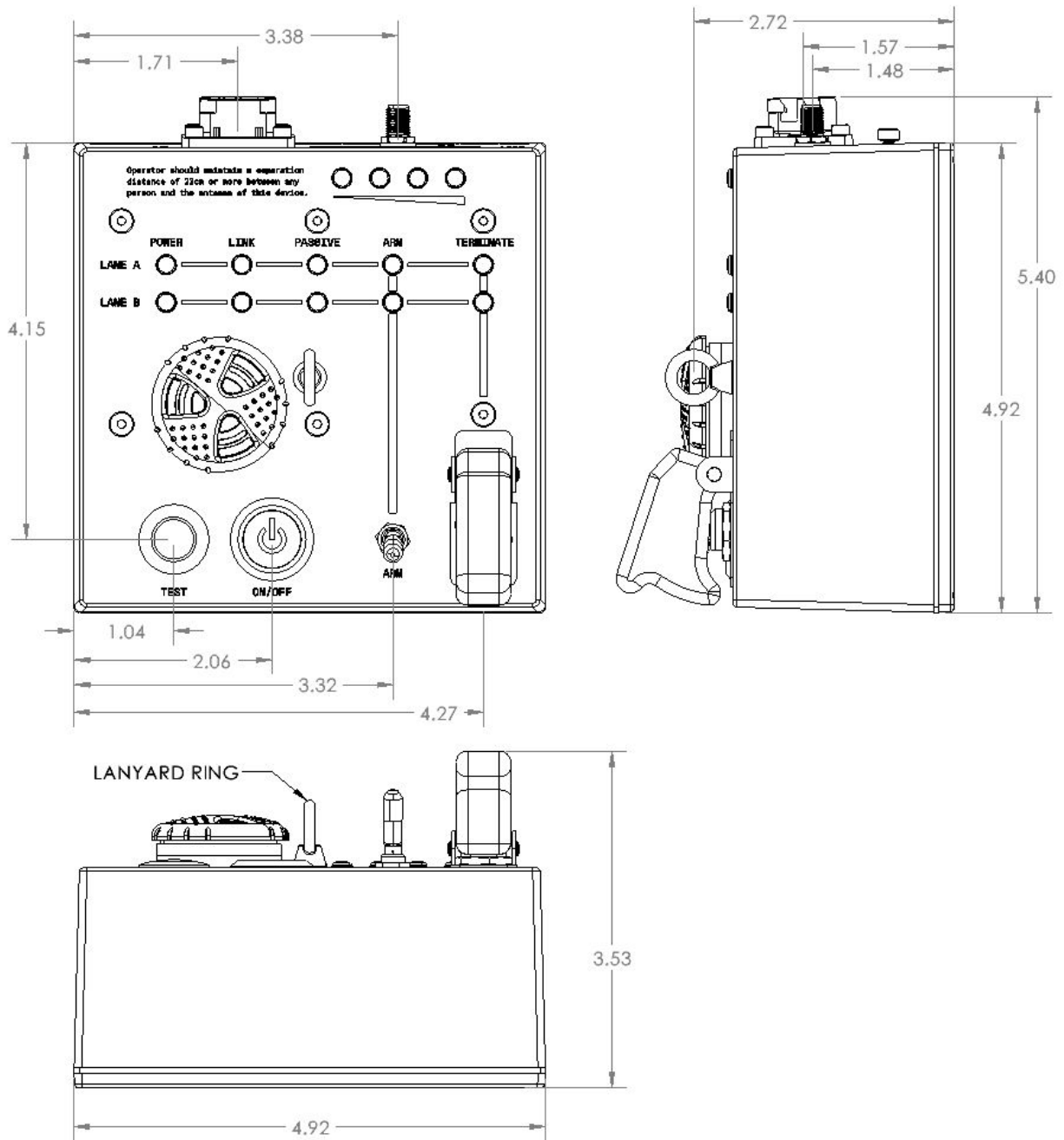

Measurements given in inches.

Attachment: N/A (handheld, lanyard optional)

Materials: Aluminum Alloy

Finish: Base: Unfinished cast aluminum

Finish, Enclosure: Powder Coat, Safety Orange, Powder Buy the Pound SK7801

Weight: 1kg (box only no antenna)