

allocortech inc.

Comet E-Stop and FTS Physical ICD

601-0049-000

Revision F

June 2024



440 N Commerce Ave
Waynesboro, VA 22980



<https://allocor.tech>



Table of Contents

Table of Contents	2	Communications Protocol	12
Version History	3	Internal Devices	13
Introduction	4	GPS	13
Scope of this Document	4	IMU	13
List of Abbreviations	5	Radio	13
References	5	Interlane UART	13
Theory of Operation	6	Non-Volatile Storage	13
As an E-Stop	6	Electrical Ratings	14
As a Flight Termination System	7	Antenna and Radio Information	15
Electrical Interface	8	902~928 MHz Option (License Free ISM Band)	15
External Connector Pinouts	8	Overview and Safety	15
J1 - Primary Connector	8	Vehicle Unit Antenna	15
J2 - RF Coax	9	Operator Unit Antenna	15
Chassis Bonding	9	Alternative Radio Modules / Frequencies	16
Internal Connectors	10	Mechanical Interface	17
JTAG Interface	10	Vehicle Unit Dimensions	17
“Harness Eliminator” Interface	10	Vehicle Unit IMU	18
Functional Interfaces	11	Operator Unit Dimensions	19
Power Topology	11	Part Number Generation	20
External Communications	12		
RS-232 and Serial Bootloading	12		
Ethernet and CAN-FD	12		
1-Wire Serial EEPROMs	12		



Version History

Revision	Changes
A	Initial Draft
B	Clarified low end operating voltage, added information about connector mate, and added information about alternative radios.
C	Added final unit weights.
D	AIR RF connector is now TNC (from BNC) Added part number creation guide.
E	Updated allocortech's physical address Renaming from AIR and GND to Vehicle and Operator Added discussion on use of Comet as an E-Stop Updated socket compatible radio list Clarified terms and wording throughout the document Added discussion of Mark II features (GPS, IMUs, EEPROMs)
F	Documented the EN-4165 pins used for the CAN alternative mode



Introduction

The allocortech inc. Comet is a remote safety system capable of operating as a vehicles emergency stop (E-Stop) or flight termination system (FTS) which is composed of a vehicle unit¹ and a small number² of operator units³. The system is designed to prevent single faults from causing an uncommanded positive voltage on the output pins, but is not designed to guarantee a positive output in the face of a single fault. When operated as an E-Stop, the software will emit a positive output as a 'run' signal, and short the output as 'stop'. When operated as a FTS, a positive output should be interpreted as 'terminate'.

The Comet vehicle unit can be factory configured with any combination of voted or non voted voltage or current outputs. In current mode, the Comet is able to fire up to a 5A pyrotechnic charge.

Each Comet unit provides auxiliary CAN or 10/100 Ethernet communication channels for telemetry and redundant termination commands. Additionally a single RS-232 port is available, which is normally used for console access but could be repurposed to communicate with something like a GPS or IMU.

Mark II versions of the Comet introduce an onboard GPS and dual IMU which can be used for autonomous actions such as geofencing, leashing operation to a radius around the operator unit, detection of impacts, and limited reversionary control.

Scope of this Document

This document covers the mechanical and electrical specifications of the allocortech inc. Comet E-Stop and Flight Termination System. As the Comet is composed of a vehicle and at least one operator unit connected via RF link, both are discussed in this document, with distinctions being made where appropriate.

¹ The vehicle unit is sometimes referred to as the Air unit for historical reasons.

² Currently up to two operator units are supported, which is primarily a software limitation. Additional operator units can be supported with changes to the reporting rates and RF link latency.

³ The operator unit is sometimes referred to as the Ground or Remote unit for historical reasons.



List of Abbreviations

ADC	Analog to Digital Converter
BRS	Ballistic Recovery System
CAN	Controller Area Network (an arbitrated 2 wire network protocol)
E-Stop	Emergency Stop
FTS	Flight Termination System
FTS-AIR	Flight Termination System - Airborne Unit (now known as the vehicle unit)
FTS-GND	Flight Termination System - Ground Unit (now known as the operator unit)
GPS	Global Positioning System
ICD	Interface Control Document
IMU	Inertial Measurement Unit (rate of turn gyroscopes and accelerometers)
MCU	Microcontroller
ms	Milli-seconds
PCB(A)	Printed circuit board (assembly)
QSPI	Quad Serial Peripheral Interface (a variant of SPI with 4 simplex data lines for faster data transfers)
RF	Radio frequency
RP-SMA	Reverse polarity sub-miniature connector A
RS-232	A 2 wire point to point communications protocol utilizing -5 to +5V signaling
TNC	Threaded Neill-Concelman radio frequency connector
TTL	Transistor/transistor logic, a low voltage electrical standard
UART	Universal asynchronous receiver and transmitter

References

allocortech 600-0049-000	Comet E-Stop and FTS Operators Manual
RTCA DO-160G	Environmental Conditions and Test Procedures for Airborne Equipment
STMicroelectronics AN3155	USART protocol used in the STM32 bootloader



Theory of Operation

Comet consists internally of a common PCB shared between vehicle and operator units with an additional indicator PCB for the operator unit. The common PCB hosts two independent output lanes (consisting of a microprocessor, arm, terminate, and safety switches) with power regulation and holdup being shared between the two lanes.

Normally a single processor controls a single output, however, as a factory option a logical AND can be added such that each output is voted upon by both processors.

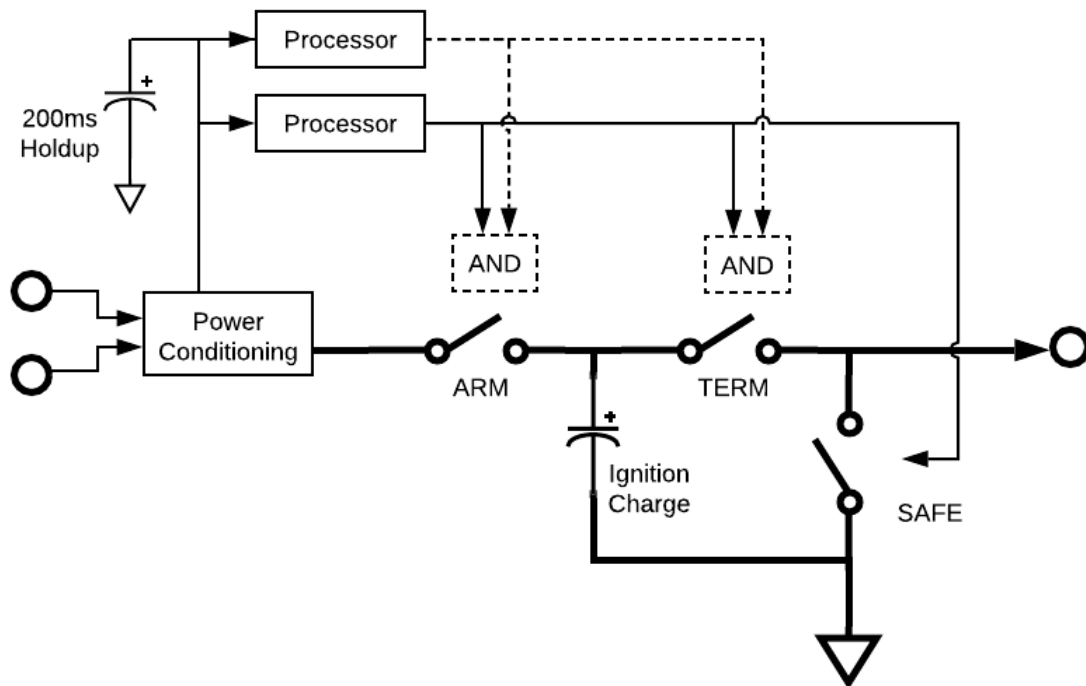

Power flow and voting schematic of a single output (one of two.) The dashed line indicates an optional voting signal from the companion lane available as a hardware defined option.

As an E-Stop

The vehicle unit starts with the output disabled and shorted to ground. Once a connection to the operator unit is established, and if all operator units are commanding 'run', the vehicle unit will open the SAFE switch and close the ARM and TERM switches to provide a positive 'run' signal. The vehicle unit will continuously evaluate if it is safe to continue operating and if it is not, it will open the ARM and TERM switches and close the SAFE switch to provide a 'stop' signal.

Standard integrations as an E-Stop include using the output to...

- Close a power contactor in the 'run' state, where removal of power would cause the contactor to open.
- Keep a motor or wheel brake open allowing motion while power is provided.



-
- Provide a digital signal to downstream motor controllers where a high voltage or a small current loop indicates 'run', and the absence of voltage or current indicates 'stop'.

As a Flight Termination System

The vehicle unit starts with the output disabled and shorted to ground. It will continuously evaluate if it has a valid termination condition, and if it does it will open the SAFE switch, close the ARM switch, allow the ignition charge capacitor to charge (if installed), and then close the TERM switch.

Standard integrations as a flight termination system include using the output to...

- Pyrotechnically fire a cable cutter to remove power from the motors.
- Pyrotechnically fire a ballistic recovery parachute.
- Provide a digital signal to downstream motor controllers where a high voltage or a small current loop indicates 'stop' and where that signal can latch.



Electrical Interface

External Connector Pinouts

J1 - Primary Connector

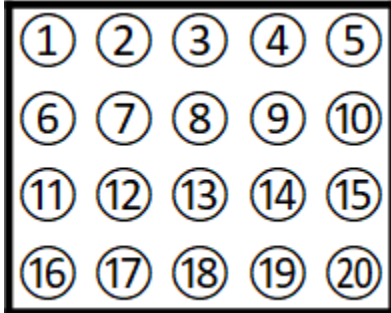

Face view of receptacle TE/DEUTSCH 732-8254-22. This connector is present on both the vehicle and operator units.

20x size 22 male pins, 5A each.

Mating Part Numbers:

Shell: EN4165M61AN

DMC-MD 20 N

Insert: EN4165A20-222NF

DMC-M20-22SNE

Pin	Name	Alt. Func.	Vehicle Unit	Operator Unit	Notes
1	FTSA +		Terminate A(+)	<unused>	
2	FTSB +		Terminate B(+)	<unused>	
3	MCU Recovery				1-Wire EEPROM Bus ⁴
4	Vin0 +		Power Bus A(+)	Battery Charger(+)	
5	Vin1 +		Power Bus B(+)	Shore Power(+)	
6	FTSA -		Terminate A(-)	<unused>	Return for Terminate A(+)
7	FTSB -		Terminate B(-)	<unused>	Return for Terminate B(+)
8	MCU Select				Bootloader ⁴
9	Vin0 -		Power Bus A(-)	Battery Charger(-)	Ground return for Vin0(+)
10	Vin1 -		Power Bus B(-)	Shore Power(-)	Ground return for Vin1(+)
11	EthA TX -				
12	EthA TX +				
13	Serial RX				Bootloader ⁴
14	EthB RX -	CAN A (High)			
15	EthB RX +	CAN A (Low)			
16	EthA RX +				
17	EthA RX -				
18	Serial TX				Bootloader ⁴
19	EthB TX +	CAN B (Low)			
20	EthB TX -	CAN B (High)			

The shell of this connector is connected to the chassis ground on both unit types.

⁴ See the section on “RS-232 and Serial Bootloading”

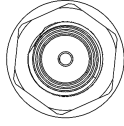

J2 - RF Coax

Vehicle Unit	Operator Unit
	
50 Ohm TNC	50 Ohm RP-SMA

Both the vehicle and operator units include a radio module inside. See the Antenna and Radio Module Information section for more details.

Lightning protection, if required, must be provided by the end user outside of the enclosure.

Care must be taken on the vehicle unit to isolate the radio ground from the chassis in order to avoid potential ground loops.

Chassis Bonding

On both units, the EN-4165 connector is connected to the chassis for shield termination. On the operator unit, so is the RF connector; but the vehicle unit's RF connector is isolated.

Vehicle Unit

A hole sized for an M3 bonding stud is provided on the vehicle enclosure if the metallic base plate is insufficient or if an independent bonding network is desired.

Electrical ground inside the enclosure (referenced to power input ground) is connected to the chassis with a $4.7M\Omega$ resistor in parallel with a $3,300pF$ capacitor. The vehicle unit electronics are designed to withstand 500V of chassis potential relative to power input ground.

Operator Unit

The operator unit enclosure is tied to the input power ground, which is normally the internal battery. External shore power input ground is tied to battery ground internally.



Internal Connectors

JTAG Interface

Each MCU has a 14-pin JTAG interface accessible inside the enclosure, which matches the ST-Link v3 14-pin debugger interface. P2 connects to MCU A, and P3 connects to MCU B.

Pin	Name	Pin	Name
1	N/C	2	N/C
3	+3.3V	4	JTMS
5	GND	6	JTCK
7	GND	8	JTDO
9	N/C	10	JTDI
11	GND	12	nRST
13	3.3V TTL USART3 RX	14	3.3V TTL USART3 TX

“Harness Eliminator” Interface

An additional debug connector P4 is provided on the PCB, with the following pinout:

Pin	Name	Pin	Name
1	Vin (*)	2	Vin (*)
3	GND	4	GND
5	MCU B nRST (†)	6	MCU A nRST (†)
7	MCU Recovery (‡)	8	GND
9	MCU Select (‡)	10	GND

(*) Vin is tied directly into the Comet power supply circuitry, bypassing fusing and overvoltage protection. Voltage supplied at this port must be limited to 30V maximum or else damage may result. It is recommended to externally limit current to 500mA.

(†) MCU [A/B] nRST lines provide direct connection to CPU nRESET lines. Connect either pin to GND to reset the corresponding MCU.

(‡) MCU Recovery and MCU Select lines operate as described in the Bootloader section of this document.



Functional Interfaces

Power Topology

Vehicle Unit

Both power inputs (Vin0 and Vin1) are diode OR'd together to power the system. Either power input may fail and the vehicle unit will remain powered and functional. If both inputs fail, the vehicle unit has a 50ms holdup capacitor for logic power.

Hardware options allow the termination outputs to be powered from either the OR'd inputs or the holdup supply. Additional capacitors can be installed between the ARM and TERM switches to provide a pyrotechnic surge, or additional holdup for the termination outputs.

Operator Unit

The operator unit is powered either by an internal, rechargeable LiPo battery or directly from a 28V nominal external supply. The internal battery and external power are diode OR'd inside the unit, meaning that the external power input voltage must be higher than that of the battery for the operator unit to operate from the external source versus drawing energy from the battery.

Vin0 is the connection to charge the battery via a dedicated battery-charger adapter. Vin1 is for the optional external power. The unit does not need to be on in order to charge.

There are charging differences between Mark I and Mark II units detailed below.

Mark I Units

The Vin0 input must be powered with an external 6S CC/CV charger limited to no more than 25.2V and 2.5A.

Mark I operator units include a BatterySpace CU-N105R pack, which is a 6 cell 2.6Ah Lithium-ion battery with included over and under discharge protection. The specific battery cells are LG ICR18650B4 B4 rated for discharge between -20 and 60 °C; and for charge between 0 and 45 °C.

Mark II Units

The Vin0 input is connected to a 8~60V absolute maximum (28V nominal) 40W buck/boost converter to charge the battery.

Mark II operator units include a BatterySpace PR-CU-R972 pack, which is a 6 cell 2.6Ah Lithium-ion battery with included over and under discharge protection. The specific battery cells are Molicel INR-18650-P28A rated for discharge between -40 and 60 °C; and for charge between 0 and 60 °C.



External Communications

RS-232 and Serial Bootloading

Both vehicle and operator units have a single RS-232 port with a lane selection input to determine which MCU will receive and transmit. This port is normally used for the configuration console and for bootloading using either the STM32 bootloader protocol (in conjunction with the boot input pin) or with the allocortech bootloader.

For console and allocortech bootloader, the default baud rate is 500 kbaud. For additional information about the bootloader and console capabilities, please consult the operators manual (allocortech P/N 600-0049-000.)

To initiate the STM32 bootloader sequence, perform the following steps:

- 1) With the unit powered off, hold the “MCU Recovery” line to power input ground
- 2) Ground the “MCU Select” line to power input ground to enter the bootloader for Lane A. Leave “MCU Select” floating to select Lane B.
- 3) Power the unit on, and begin the bootloader sequence defined in AN3155.

Ethernet and CAN-FD

Each MCU lane can provide an IEEE 802.3u 10/100 Auto MDI-X Ethernet port available on the EN-4165 connector. As a hardware option, Lane B's ethernet pins can instead expose lane A and B CAN-FD.

Each MCU lane is connected to an independent 5V CAN-FD transceiver, which can optionally be exposed on the EN-4165 connector instead of lane B ethernet. These transceivers are not electrically isolated.

1-Wire Serial EEPROMs

Connected to the MCU Recovery pin is an internal 1-Wire serial EEPROM used for storing the unit part number, serial number, and other manufacturing information. As this bus is exposed externally, an additional 1-Wire EEPROM may be connected in the harness in order to store configuration information such as vehicle ID and lane keys in order to ease the transition of an operator unit from vehicle to vehicle.

Communications Protocol

For more information on the default message format used on the Ethernet and CAN buses, please consult the operators manual. This protocol can also be customized as needed by the end user's software; contact allocortech for more information if interested.



Internal Devices

Details on internal devices are provided in case the integrator identifies a need for custom capabilities beyond the basic “operator provides a command, vehicle takes an action.” For more information on custom software, including allocotech’s software development kit and contract software development, please send an email to info@allocor.tech.

GPS

Comet Mark II introduced a U-Blox Max-M10S module onto the common PCB. Lane A can transmit to the GPS for configuration, both lanes can receive from the GPS. For active antennas, up to 100mA of 3.3V or 5.0V can be injected into the RF receive path.

allocortech does not have a recommended GPS antenna at this time.

IMU

Comet Mark II introduced two IMUs for crash (jerk) detection or for possible reversionary control of the vehicle. Each lane controls its own IMU and can share data across the interlane UART if needed. For specifications of the IMUs, please refer to the Bosch BMI-088 (lane A) and the TDK Invensense IIM-42652 (lane B) datasheets.

Orientation information for the two IMUs can be found in the Vehicle Unit IMU Axes section of this document.

Radio

The Microhard radios have two TTL UARTs connected to the MCUs, one for data and one for diagnostics. Both lanes can always receive on the data link, but lane A controls a multiplexor for the data transmit which is connected to hardware flow control on the two MCUs. Only lane A can communicate on the diagnostics link. Notionally the radio emits a synchronization pulse at every N hopping intervals to coordinate clocks between the two lanes.

Interlane UART

There is an internal TTL UART that connects the two lane MCUs together for the purpose of sharing ADC data and for forwarding externally and internally generated messages onto and from the Ethernet link when the single Ethernet and dual CAN hardware option is selected. This link can also be customized by the end user’s software as needed.

Non-Volatile Storage

Comet Mark I had pads for a 128 MB NOR flash connected over QSPI, but the parts were never populated.

Comet Mark II added 1 GB SLC NAND flash devices connected over QSPI to each lane for use in data logging if the end user’s application desires.



Electrical Ratings

	Spec	Min	Nom	Max	Units
Voltage Input <i>Vehicle Unit: Vin0, Vin1</i> <i>Operator Unit: Vin1</i>	DO160G 16.6.1.1 (Cat B)	18.0 (*)	28.0	30.3 (‡)	V
<i>Operator Unit: Vin0</i>					
Mark I	Use Supplied Charger				
Mark II		8.0	28.0	60.0	V
Power Draw <i>Vehicle Unit</i>			5	10	W
<i>Operator Unit</i>			5	40	W
Terminate (A/B)		Terminate outputs follow MAX(Vin0, Vin1)			V
Terminate Current (Digital Configuration)			50	100	mA
Terminate Energy (Squib Configuration)				0.26	J
Serial TX High Level Low Level	RS232	5.0	5.4 -5.4	-5.0	V V
Serial RX High threshold Low threshold Operating limit	RS232	0.8 -25	1.8 1.5	2.4 +25	V V V
Ethernet (A/B)	IEEE 803.2u				
MCU Recovery	3.3V TTL	0		3.3	V
MCU Select	3.3V TTL	0		3.3	V
RF Output (900MHz)				1 (‡)	W

(*) Error free operation down to 16V anticipated by component specification, holdup time of 50ms only guaranteed when starting from 28V

(‡) Surge to 60V per DO160G 16.6.2.4

(‡) Limited by Microhard P900 radio, different bands have different power limits



Antenna and Radio Information

902~928 MHz Option (License Free ISM Band)

The default radio option for Comet is a 1W 900 MHz channel hopping radio. The hopping key is derived from the vehicle lane key and vehicle ID to minimize interference with other Comet units and any other equipment operating in the 900MHz ISM band. If needed, band limiting can be implemented in software to further prevent interference with other systems.

Operation in countries other than the United States or Canada is possible, but will need to be discussed with allocortech and Microhard Corp to ensure a compliant solution.

Overview and Safety

The radio module used in this product complies with Part 15 of the FCC rules. Operation is subject to the following two conditions: (1) this device may not cause harmful interference, and (2) this device must accept any interference received including interference that may cause undesired operation.

FCC ID: NS913P900
Industry Canada ID: 3143A-13P900

To satisfy FCC RF exposure requirements for mobile transmitting devices, a separation distance of 23cm or more should be maintained between the antenna of these devices and all persons during device operation. To ensure compliance, operation at closer than this distance is not recommended.

The Comet Vehicle and Operator antennas should be kept as far as practical from any other antenna (including another FTS unit antenna), with a minimum of 2 feet of separation.

FCC Regulations allow up to 36dBm Effective Isotropic Radiated Power (EIRP). Therefore, the sum of the transmitted power (in dBm), the cabling loss and the antenna gain cannot exceed 36dBm. The transmit power of each unit is set to 30dBm by default but can be set as low as 23dBm via custom software.

Vehicle Unit Antenna

The following antennas are suggested for application for the vehicle unit when installed on the skin of an aircraft:

- 1) Dayton-Granger L10-793
- 2) Haigh-Farr 6108

The vehicle unit antenna requires a $\frac{1}{4}$ wavelength ground-plane (at 900MHz) that is electrically isolated from the airframe. This is a 8cm radius circle minimum.

Operator Unit Antenna

For handheld use of the operator unit, a 900MHz monopole RP-SMA antenna (eg “rubber duck”) is recommended⁵. Alternatively, for stationary use, connecting a low-loss coax feed-line

⁵ When purchasing operator units, allocortech typically provides a Nearson S1551AH-915S.



to a fixed antenna may be desirable, as long as all precautions and limitations outlined in this section are observed.

Alternative Radio Modules / Frequencies

Comet utilizes a socketed Microhard Systems Pico series radio. With no hardware effort, any Pico series radio is compatible with the power delivery and connector system used inside the Comet. See Microhard Corporations website for more details, but as of February 2023, the additional frequency bands available are:

Band	Operating Mode	Maximum Power	Approvals
400MHz	Fixed Frequency	2W	License Required
840 - 845 MHz	Fixed Frequency	2W	License Required
	Frequency Hopping	1W	No data
865 - 867 MHz	Frequency Hopping	1W	Pending
869.25 - 869.75 MHz	Frequency Hopping or Fixed Frequency	500mW	CE Approval Pending
902-928 MHz	Frequency Hopping	1W	FCC, Industry Canada, Anatel
2.200 to 2.300 GHz	Frequency Hopping	1W	No data
2.400 to 2.4835 GHz	Frequency Hopping	2W	FCC, Industry Canada, CE, Japan Mic

On request, allocortech will consider making adapter boards for alternative radios and frequencies.



Mechanical Interface

Vehicle Unit Dimensions

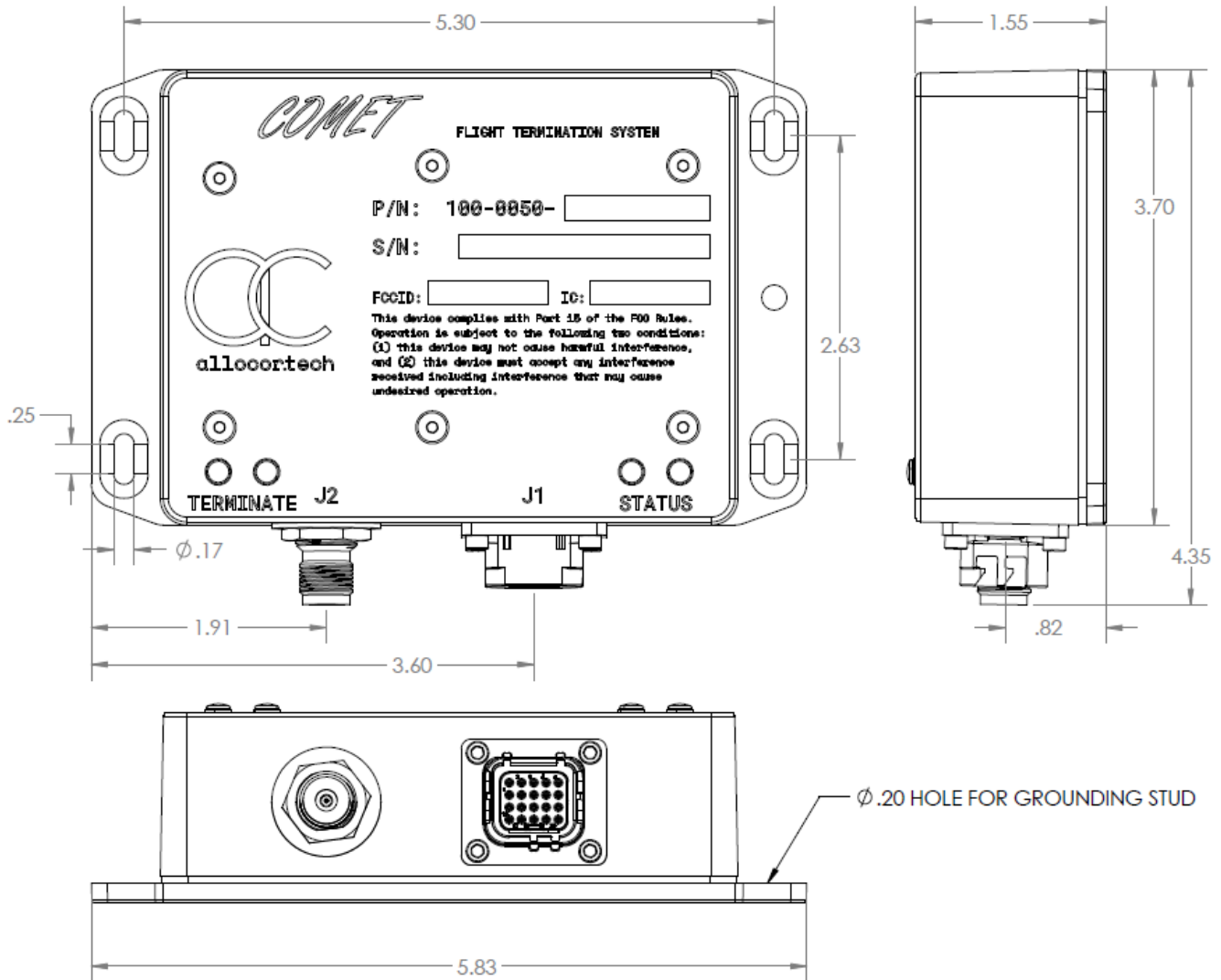

Measurements given in inches.

- Attachment: 6-32 x 0.5-in screws on 2.63" x 5.30" square pattern.
- Materials: Aluminum Alloy
- Finish, Base: Mark I: Unfinished cast aluminum
Mark II: Chromate converted billet aluminum
- Finish, Enclosure: Powder Coat, Blue Purple (Flip Flop), Powder Buy the Pound SK19811
- Weight: 375g (box only no antenna)



Vehicle Unit IMU

Both IMUs are installed on the bottom side of the PCBA. Lane A controls the Bosch BMI-088, Lane B controls the Invensense IIM-42652. When viewed as shown below, both devices positive Z points into the page. As a general statement, positive rates follow the right hand rules.

Comet does not embed a magnetometer, if one is needed the integrator needs to connect it via CAN, Ethernet, or RS-232.

Consult the manufacturer's data sheets for more information on the range, bias, and noise figures of the two embedded IMUs.

Offsets and Rotations:

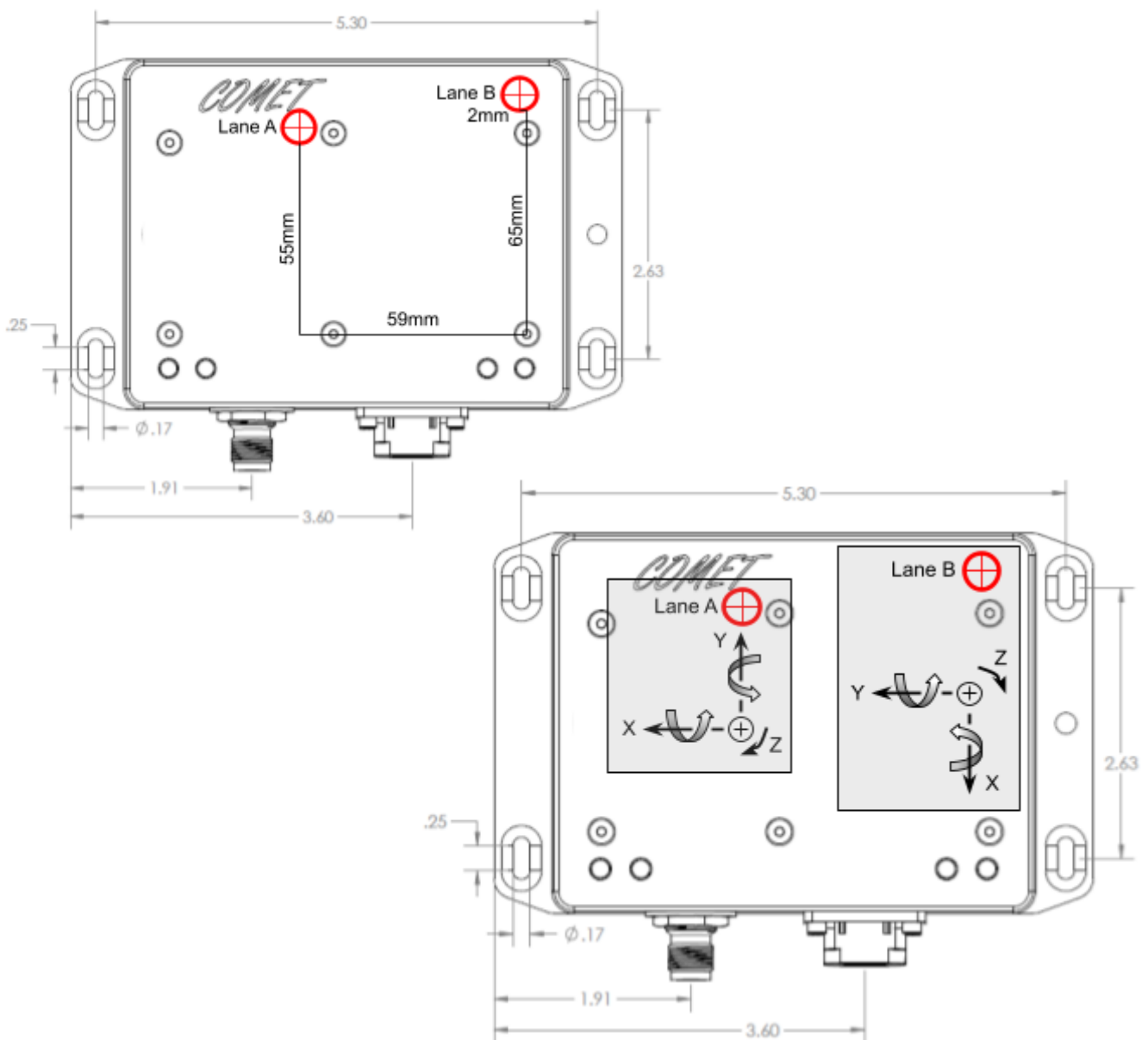



Operator Unit Dimensions

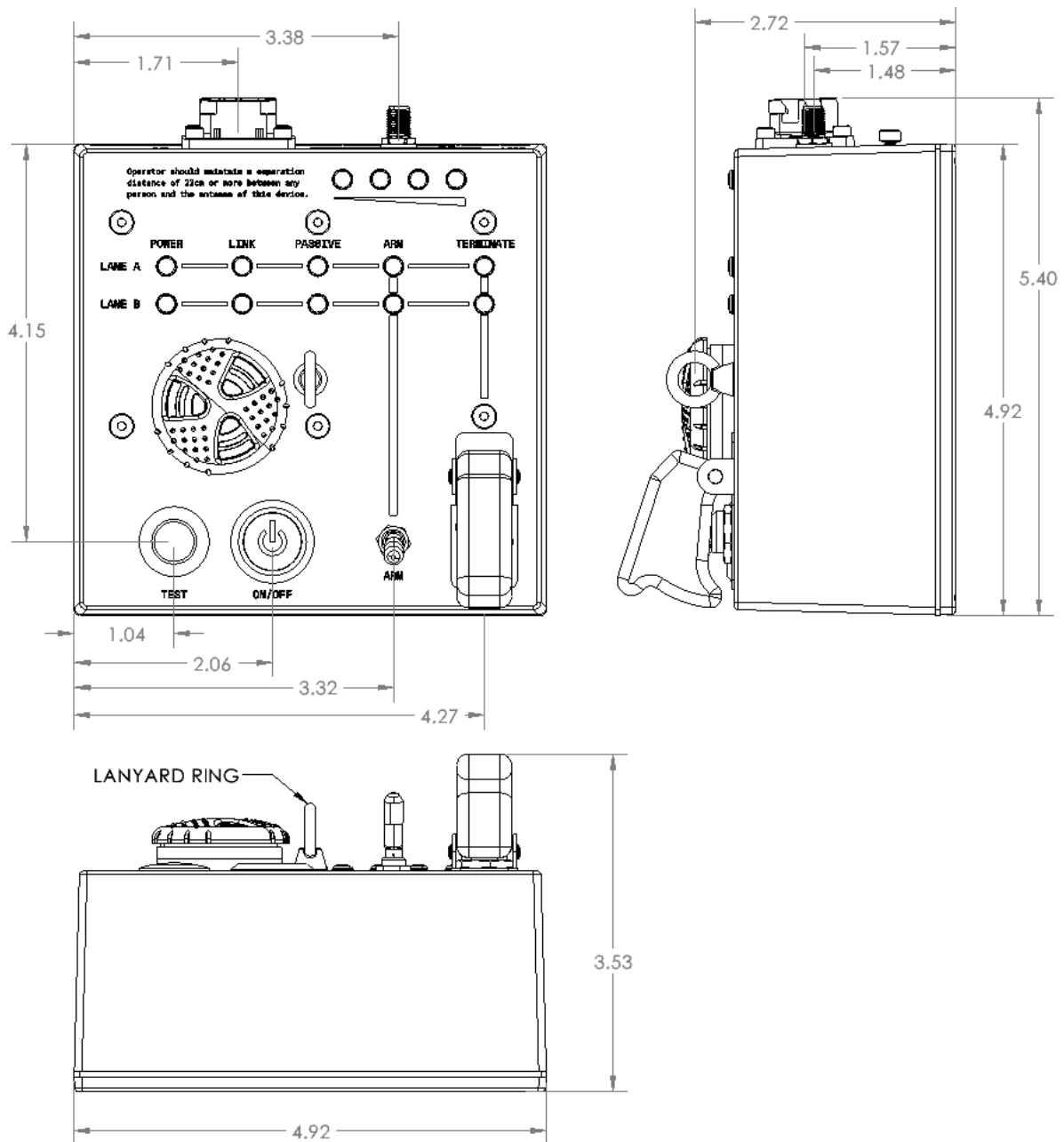

Measurements given in inches.

Attachment:	N/A (handheld, lanyard optional)
Materials:	Aluminum Alloy
Finish: Base:	Cast aluminum with clear iridite
Finish, Enclosure:	Powder Coat, Safety Orange, Powder Buy the Pound SK7801
Weight:	1kg (box only no antenna)



Part Number Generation

To generate a part number suffix for a Comet:

- Write the option letter in the Option Code column.
- The part number suffix is read down the Option Code column.

100-0050-		Option Code
Communication	Choose: E (Dual Ethernet) or C (Dual CAN, Lane A Ethernet)	
Lane Coordination	Choose: Interlane UART P(resent) or R(emoved)	
Termination Power Lane A Lane B	Choose: I (Input line power) or H (Tied to internal hold up rail, limited to 33V)	
Termination Voting Lane A Lane B	Choose: S (Lane has complete control) or V (Lanes must vote to terminate)	
Termination Latching Lane A Lane B	Choose: L (Once terminated, signal is latched in hardware) or T (Signal is controlled completely in software) NOTE: Latching only available with "S" Voting option.	
Termination Type Lane A Lane B	Choose: D (100mA limited logic signal) or X (Explosive squib trigger)	
Radio Link	Choose: 900 (Microhard P900) TBD (Other Microhard radios available upon request)	
GPS Antenna Power	Choose: 3 (3.3V) 5 (5.0V)	

Note: Differentiation between Mark I and Mark II units

When the three digit variant code is created, they will be XNN where

- X = 0 indicates Mark I
- X = 1 indicates Mark II

Unfortunately the Mark I Comet is not currently available for purchase due to supply chain shortages of critical parts. Where changes to the Mark II Comet were made to accommodate, allocortech attempted to keep the form, fit, function, and failure modes identical.