

SportBench Assembly

P/N: 620 - 00153 - 00 REV 2.1

Thank you for purchasing the PowerBlock SportBench. If you have any questions concerning this product, please call customer service at 507-451-7397

STEP ONE:

The image to the right shows the Wheel Base in position to fasten to the Bench Frame.

Place the Wheel Base tight against the Bench Frame. Align holes of Wheel Base and Bench Frame.

Insert provided M10 - 1.5mm x 80mm bolts, washers, and nuts. Tighten bolts/nuts with 17mm or 11/16in wrenches.

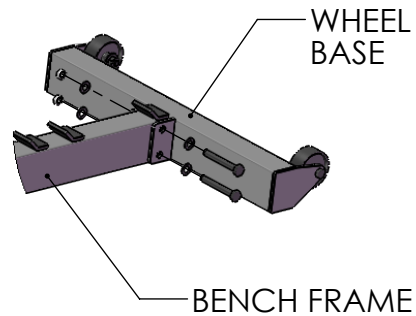

STEP TWO:

The image to the right shows an exploded view of the Front Foot assembly.

Place the Front Foot tight against Bench Frame. Align holes of the Front Foot and Bench Frame

Insert provided M10 - 1.5mm x 95mm bolts, washers, and nuts. Tighten bolts/nuts with 17mm or 11/16in wrenches.

Tighten all bench pad bolts before use.

IF BACK PAD WIGGLES OR FEELS LOOSE, TIGHTEN BACK PAD BOLT.

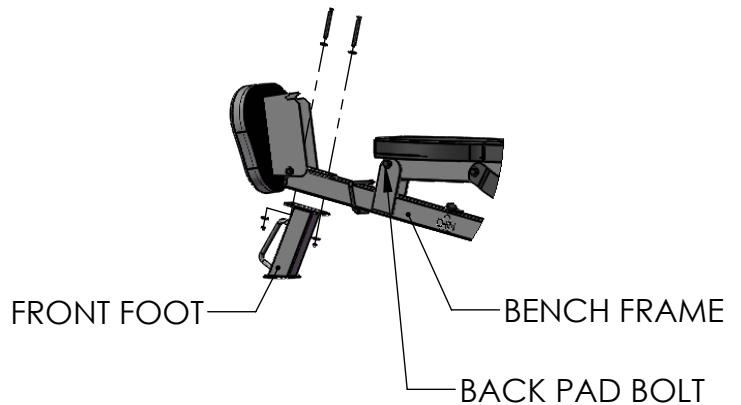

NOTE: Wheels should be just above floor when Sport Bench assembly is finished. If wheels are touching floor flip the Wheel Base over.

NOTE: 550 lb. Max Load.

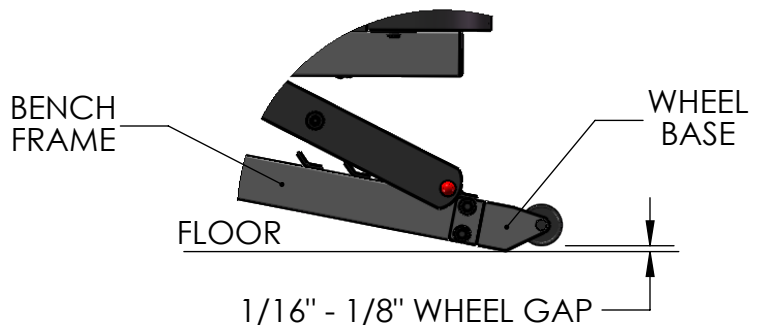

PLEASE READ THE FOLLOWING BEFORE USING YOUR BENCH

This bench was designed and manufactured to allow your workouts to flow as smoothly as possible and minimize adjustment/set-up time. The SEAT PAD ASSEMBLY was designed to lower your hips and elevate the knee when doing incline bench work. This allows you to sit more comfortably and keep your feet on the floor. The amount of space between both cushions has also been minimized for user comfort and there are no hinges or metal parts to straddle. The bench also allows you to change from the flat to incline position with two simple adjustments.

Whenever changing the bench to the incline position always set the SEAT PAD PIVOT ARM to the position shown in the figure at right. Set the SEAT PAD ASSEMBLY as shown before adjusting to the desired angle of the BACK PAD. When changing from an incline position to flat, remember to lower the BACK PAD first, then raise the SEAT PAD ASSEMBLY to the flat position.

