

## **High Backed Height Adjustable Chair**



## **Usage and Maintenance Instructions**

**DO NOT EXCEED THE WEIGHT LIMIT- Doing so could put the user at risk.**

N.B. It is recommended that this equipment is installed by a competent person and a risk assessment is undertaken as to the suitability for the user. **Do not use on uneven surfaces.**

### PARTS LIST

Ensure all parts are present before assembly. Contact your supplier if any parts are missing.

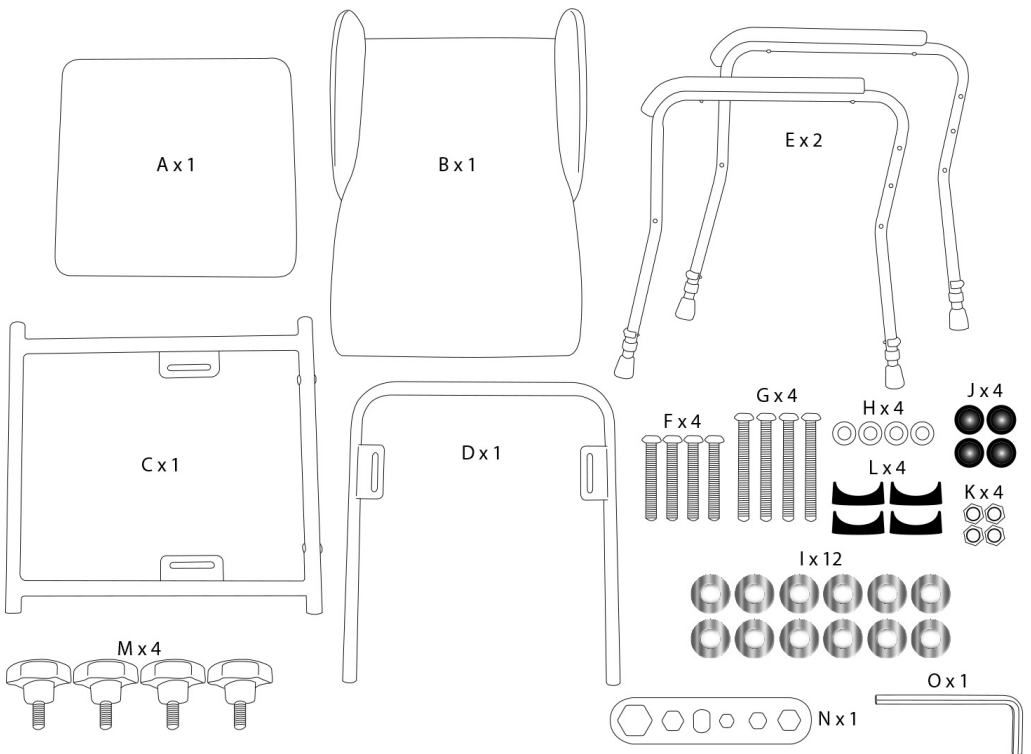

- |                     |                   |
|---------------------|-------------------|
| A: Padded Seat      | H: Washer         |
| B: Padded Back Rest | I: Curved Washer  |
| C: Seat Frame       | J: Bolt Cover Cap |
| D: Rear Seat Frame  | K: Nut            |
| E: Chair Sides      | L: Plastic Spacer |
| F: Bolt (Short)     | M: Thumb Wheels   |
| G: Bolt (Long)      | N: Spanner        |
|                     | O: Allen Key      |

**ASSEMBLY:**

**Requires at least 2 people for assembly.**

Assemble the chair as per the assembly instructions below.

**DIRECTIONS:**

1) Attach seat frame (C) to chair sides (E), using short bolt (F), a plastic spacer (L) and 1 curved washer (I).

- **Ensure seat brackets are facing up, and ensure Aidapt label is at the back. (fig. 1)**
- **Foam handles facing forwards.**
- **Label at back.**
- **Brackets facing up.**

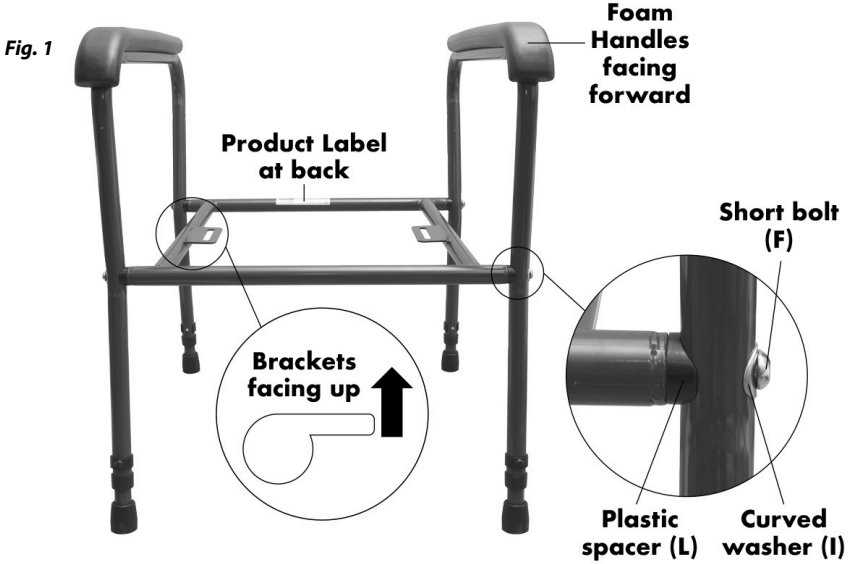

2) Use an allen key (O) to attach rear seat frame (D) to chair sides (E), ensuring rear seat frame brackets (fig. 2) are on the inside, using long bolt (G), 3 washers (H) and 1 nut (K). (fig. 3)

Repeat this step to ensure there are 2 bolts (G) fastened on both sides.

Ensure bolts (G) are tightened for use, then cover end of bolt using bolt cover caps (J). (fig. 4) Use spanner (N) to put on nut (K).

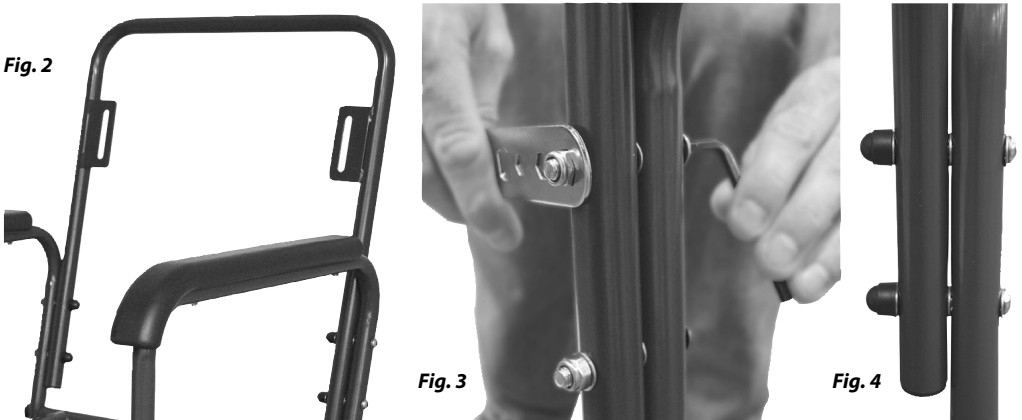

3) Attach padded seat (A) to seat frame (C) using 2x thumb wheels (M), ensuring they are attached tightly. (fig. 5)

**Please Note:** Padded seat can be moved forward or backward.



**Fig. 5**

4) Attach padded back rest (B) to rear seat frame (D), using 2x thumb wheels (M), ensuring they are attached tightly. (fig. 6)

**Please Note:** Padded back can be moved upwards or downwards.



**Fig. 6**

### ADJUSTING SEAT & BACK POSITION

The back and seat can be adjusted to suit the user's requirements. Simply unscrew the 2x thumb wheels (M) (fig. 5 or fig. 6), reposition the back of seat as required, then tighten both thumb wheels.

### CLEANING

A useful guide to decontamination is MHRA leaflet DB2003(06).

**Do not** use abrasive cleaners as this could damage the surface of the equipment. For cleaning, wipe with a clean cloth soaked in detergent solution and wring out. Depending on the detergent manufacturer's instructions, the solution may be heated.

- Wipe all surfaces of the equipment and the cloth should be re-immersed periodically and the detergent changed frequently. The detergent should be rinsed or wiped off using a clean cloth immersed in clean water and wrung out.
- To disinfect, make sure the equipment has been cleaned and dried and then wipe over with a clean cloth and a compatible liquid disinfectant. After disinfecting, clean with clean water and dry.
- When using detergent or disinfectants, please refer to manufacturers' instructions, and if unsure, please consult your local Infection Control Specialist for advice.
- This product is not suitable for cleaning with moist heat or autoclaving.

### REISSUE

If you reissue or are about to reissue this product then please check all components for safety and in particular tighten all the nuts and bolts, that the chair is steady, no rips or splits in the upholstery, and that the 'E' clips are fitted correctly.

## SPECIFICATIONS

Height to top of backrest .....	1050- 1285mm
Footprint of Chair .....	540 x620mm
Width of seat to inside of arm rest .....	460mm
Width of seat to outside of arm rest .....	570mm
Height to top of seat cushion .....	440mm
Net weight .....	15.4kg

## HEIGHT ADJUSTMENT

Remove the 'E' clip from the extension leg and extend all legs evenly to the desired height, ensuring you do not exceed the last punched hole of the extension leg. (fig. 7)

Once you have achieved the desired height, reinstall the 'E' clip, ensuring that it has passed through the extension leg and is fitting neatly and snug around the outside leg. (fig. 8 and fig. 9)

Make sure same holes are used on each leg. If the legs are fitted unevenly or slanted, then this could compromise the safety of the user.

