

Smart lift SL580

Produktinformasjon og spesifikasjoner

Smart lift SL580

STANDARDUTSTYR

- 24-volts motor med 1000 watt
- Pålitelig 2-krets vakuumsystem
- Sideforskyver 100 mm til hver side
- 24-volts aktuatorer som gjør installasjonen mer presis
- Funksjonell akselerator
- Nyttig og kompakt
- Multifunksjonell
- 2-krets vakuumsystem
- Sparer bemanning
- Forbedrer arbeidsmiljøet
- 4 store sugekopper (Ø 400 mm) som hver tar 580 kg
- Fleksibelt hode som kan snus 180 grader
- Selvgående
- Attraktiv pris

SPESIFIKASJONER

	Vidde (minimum)	780 mm
	Lengde (minimum)	1700 mm
	Forlengelse av arm	500 mm
	Sideforskyver	100 mm
	Høyde	1420 mm
	Spissen fra horisontalen	30° baklengs / 100° forlengs
	Fremdriftsmotor	1000 Watt
	Batteri (2 x 12 V) 24 Volt	2 x 90 A
	Brukertid	Omtrent 30 timer
	Integrert lader	Cetek XT 14000
	Ladetid	Omtrent 8 timer
	Lader med spenningstilførelse	230 volt
	Vakuumsystem	2-krets
	Sugerkopper	4 x Ø400 mm
	Automatisk sugning	Ja
	Vekt	697 kg

LASTING DIAGRAM

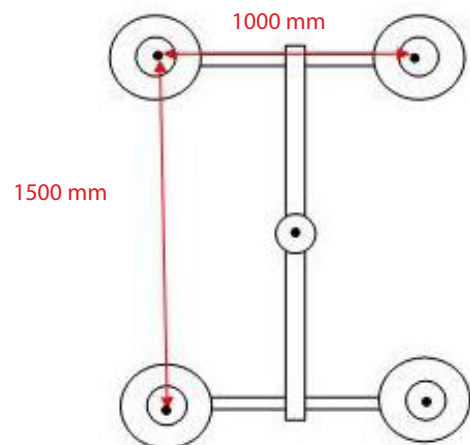
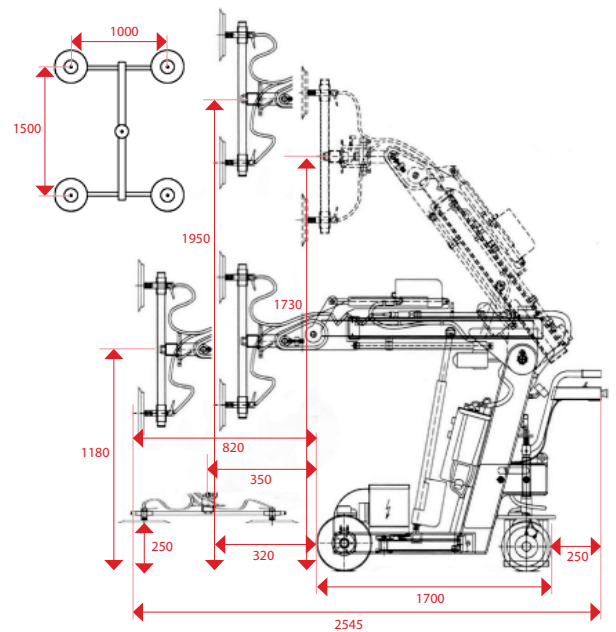

www.instant.no

INSTANT

Norway

Tel.: +47 23 19 11 00
info@instant.no

Lithuania

Tel.: +370 5 233 1096
info@instant.lt

Latvia

Tel.: +371 263 58 152
info@instantlatvija.lv

Estonia

Tel.: +372 680 76 33
info@instant.ee