

The Shops at Sterling Ponds

33345 Van Dye Ave., Sterling Heights, MI 48312



Located at the heavily traveled intersection of Van Dyke Road and 14 Mile Road in Sterling Heights, Michigan. A corner pond with fountains, inviting landscape areas, benches and other features encourage shoppers to linger and explore the shops. Strong tenant mix includes: Super Walmart, Value City Furniture, Sally Beauty Supply, Xfinity by Comcast and great restaurants including: Hibachi Buffet, Leo's Coney Island and Alie's Lebanese Grill.

Details:

Floor: 1st
SF Available: 2,733ft²

Service Type: Triple Net
Full-Build Out
Ideal for Retail or Restaurant Industry

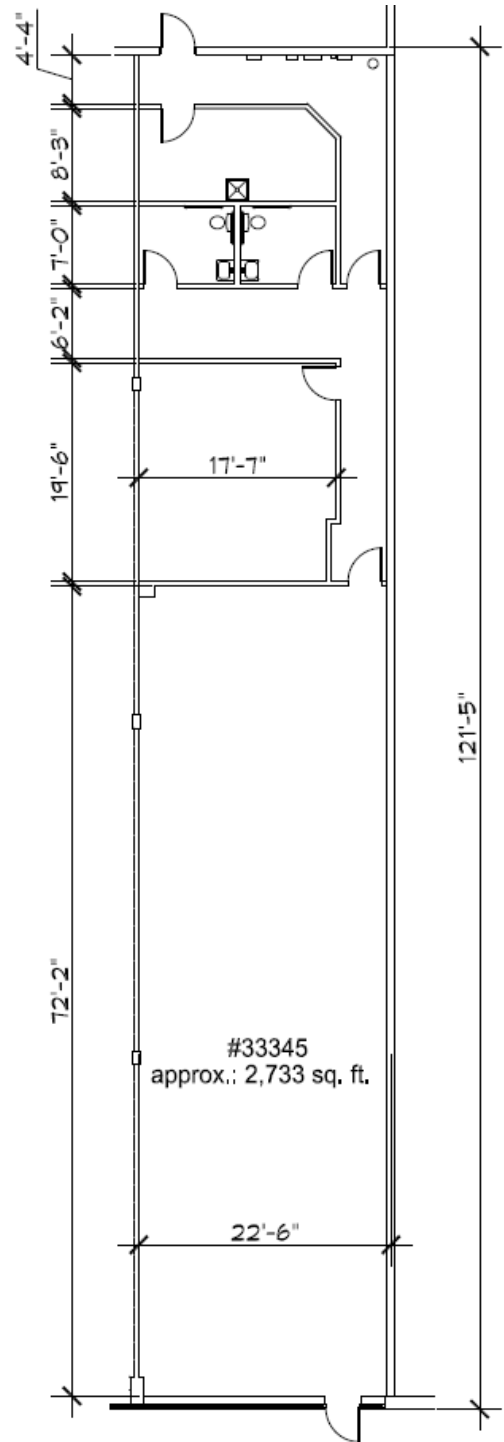

Leasing Information Contact
586.786.7600 | info@gallogroups.com
6303 26 Mile Rd. 2nd Floor
Washington Twp., MI 48094