

Clark County, IN

Summary

Parcel Number 10-24-04-500-494.000-013
Alt Parcel Number 24-00070-008-1
Property Address 122 Bowling Lane
Class Code 420
Property Class Small Detached Retail of Less Than 10,000 Square Feet
Nbhd Code 10044051
Neighborhood JTCTGCOFW13 COM AREA 37
Legal Description GT 45.459 AC
Township JEFFERSONVILLE TOWNSHIP
Corporation GREATER CLARK COUNTY
Taxing District 013 - CLARKSVILLE TOWN-GCS-OFW



Owners

[Red Stag Holdings LLC](#)
 24726 Crowe Road
 Borden, IN 47106

Land

Land Type	Acres	Dimensions
11 - PRIMARY	0.46	

Transfer of Ownership

Date	Name	Document	Deed Type	Sale Price
10/5/2021	Red Stag Holdings LLC	202125586	QC	\$0
6/6/2019	Crane Carl & Nicole Rachelle	201910134	WR	\$125,000
2/4/2009	B & T EQUITY VENTURES LLC		WD	\$0
11/7/1997	RENFRO GARY W. & RHONDA D.		WD	\$0

Valuation Record

Assessed Year	2025	2024	2023	2022	2021
Assessment Date	2025-04-17	2024-04-18	2023-04-06	2022-04-14	2021-03-31
Reason for Change	ANNUAL ADJUSTMENT	ANNUAL ADJUSTMENT	ANNUAL ADJUSTMENT	ANNUAL ADJUSTMENT	ANNUAL ADJUSTMENT
Land	\$45,400.00	\$45,400.00	\$45,400.00	\$45,400.00	\$45,400.00
Improvements	\$105,000.00	\$79,600.00	\$81,300.00	\$88,200.00	\$79,600.00
Total Valuation	\$150,400.00	\$125,000.00	\$126,700.00	\$133,600.00	\$125,000.00

Sales

Sale Date	Sale Price	Buyer Name	Seller Name
5/31/2019 8:45:52 AM	\$125,000	Crane Carl & Nicole Rachelle	B & T EQUITY VENTURES LLC
1/26/2009 12:00:00 AM	\$71,000	MATTHEW TOOLE	GARY W RENFRO

Public Utilities

Water N
Sewer N
Gas N
Electricity N
All N

Exterior Features

Exterior Feature	Size/Area
Stoop, Masonry	35
Canopy, Roof Extension	35

Summary of Improvements

Buildings	Grade	Condition	Construction Year	Effective Year	Area
C/I BUILDING	C-1	A	2013	2013	1,482
Paving, Asphalt 1	C	A	1996	1996	2,000

Commercial Buildings

Building	C/I BUILDING	Area	1,482	Area AC	Area Heat
Floor	Usage	Area in Use			
1	General Office	1,482		1,482	1,482

Tax History

Tax Year	2024 Pay 2025	2023 Pay 2024	2022 Pay 2023	2021 Pay 2022	2020 Pay 2021
+ Spring Tax	\$1,875.00	\$1,900.50	\$2,004.00	\$1,875.00	\$1,875.00
+ Spring Penalty	\$0.00	\$0.00	\$0.00	\$0.00	\$0.00
+ Spring Annual	\$0.00	\$0.00	\$0.00	\$0.00	\$0.00
+ Fall Tax	\$1,875.00	\$1,900.50	\$2,004.00	\$1,875.00	\$1,875.00
+ Fall Penalty	\$0.00	\$0.00	\$0.00	\$0.00	\$0.00
+ Fall Annual	\$0.00	\$0.00	\$0.00	\$0.00	\$0.00
+ Delq NTS Tax	\$0.00	\$0.00	\$0.00	\$0.00	\$0.00
+ Delq NTS Pen	\$0.00	\$0.00	\$0.00	\$0.00	\$0.00
+ Delq TS Tax	\$0.00	\$0.00	\$0.00	\$0.00	\$0.00
+ Delq TS Pen	\$0.00	\$0.00	\$0.00	\$0.00	\$0.00
+ Other Assess	\$0.00	\$0.00	\$0.00	\$0.00	\$0.00
+ Fees	\$0.00	\$0.00	\$0.00	\$0.00	\$0.00
PTRC	\$0.00	\$0.00	\$0.00	\$0.00	\$0.00
HMST Credit	\$0.00	\$0.00	\$0.00	\$0.00	\$0.00
Circuit Breaker	\$775.21	\$650.66	\$605.76	\$648.68	\$1,083.92
Over 65 CB	\$0.00	\$0.00	\$0.00	\$0.00	\$0.00
= Charges	\$3,750.00	\$3,801.00	\$4,008.00	\$3,750.00	\$3,750.00
- Surplus Transfer	\$0.00	\$0.00	\$0.00	\$0.00	\$0.00
- Credits	(\$3,750.00)	(\$3,801.00)	(\$4,008.00)	(\$3,750.00)	(\$3,750.00)
= Total Due	\$0.00				

Sketches

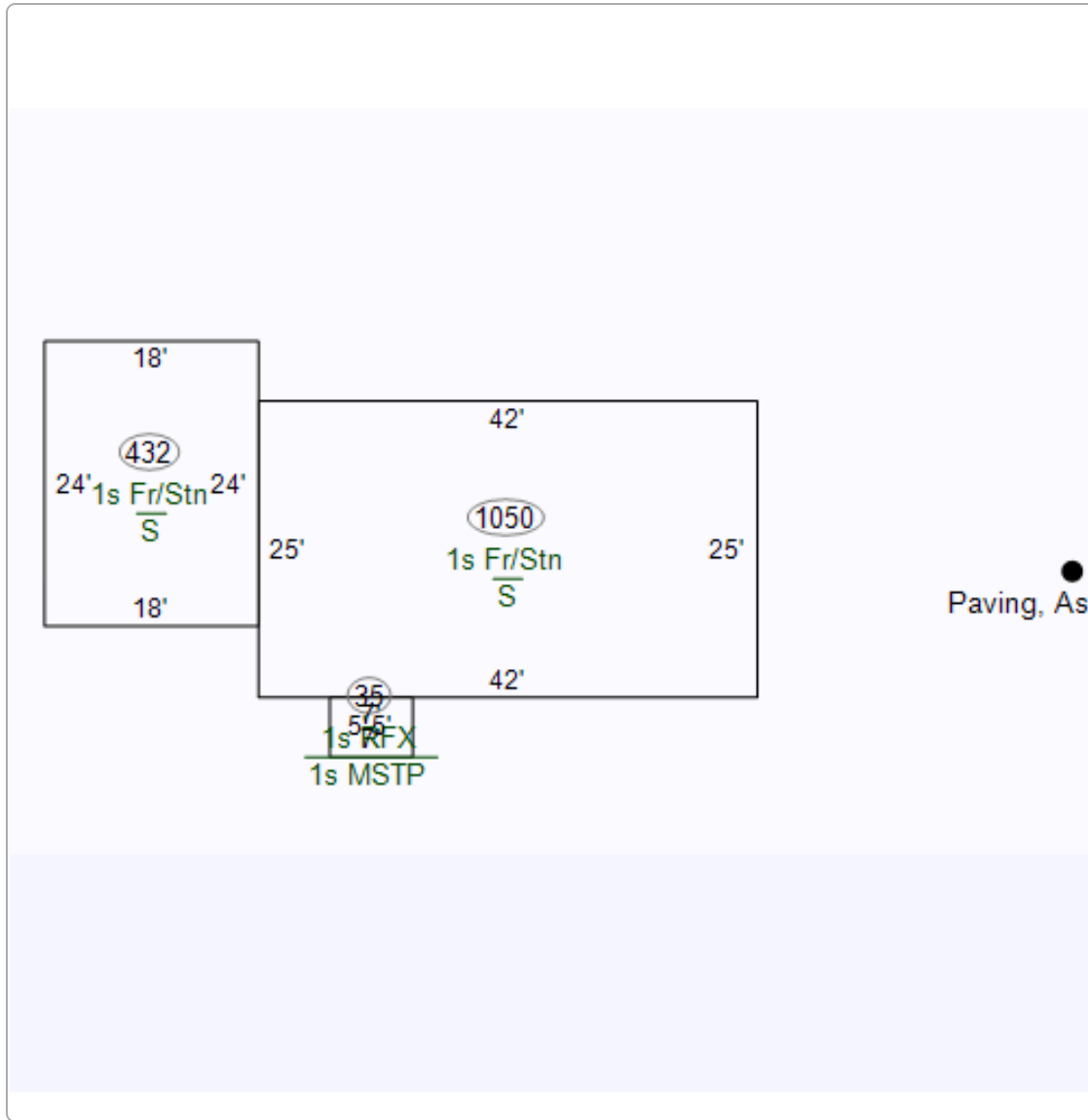

Photos





Map



No data available for the following modules: Sales Disclosures, Special Features, Residential Dwellings, Tax Deductions, Plat.

All the data represented within this application is for public information services only. The data is updated as provided by the county. The data contained within this application should not be used for legal purposes.

[User Privacy Policy](#) | [GDPR Privacy Notice](#)
Last Data Upload: 2/9/2026, 6:17:19 PM

Contact Us

Developed by
 SCHNEIDER
GEOSPATIAL

10-24-04-500-494.000-013

Red Stag Holdings LLC

122 BOWLING LANE

420, Small Detached Retail of Less Than

JTCTGCOFW13 COM ARE

1/2

General Information

Parcel Number 10-24-04-500-494.000-013
Local Parcel Number 24-00070-008-1
Tax ID:

Ownership

Red Stag Holdings LLC
24726 Crowe Road
Borden, IN 47106

Legal

GT 45 .459 AC

Routing Number 122.000

Property Class 420
Small Detached Retail of Less Than



Transfer of Ownership

Table with columns: Date, Owner, Doc ID, Code, Book/Page, Adj Sale Price, V/I. Rows include transactions from 10/05/2021 to 11/07/1997.

Notes

8/28/2024 GENERAL : REASSESSMENT; 25/26-UPDATED GRADE AND MRKT FACTOR ON C/I BUILDING. EB/GI
1/27/2022 GENERAL : 22-23 -- BUILDING PERMIT -- LG/KS -- NO RECHECK NO CHANGE
3/9/2021 GENERAL : F-134 (20-21) AGREED TO A TOTAL ASSESSED VALUE OF \$125,000. APPEAL IS SETTLED.
11/16/2020 GENERAL : 20/21 - BUILDING PERMIT -- LG/KS -- CHANGED BUILDING USAGE RECHECK 22/23

Year: 2025

Location Information

County Clark
Township JEFFERSONVILLE TOWNSHIP
District 013 (Local 024) CLARKSVILLE TOWN-GCS-OFW
School Corp 1010 GREATER CLARK COUNTY
Neighborhood 10044051 JTCTGCOFW13 COM AREA 37
Section/Plat
Location Address (1) 122 BOWLING LANE CLARKSVILLE, IN 47129

Valuation Records (Work In Progress values are not certified values and are subject to change)

Table with columns: Assessment Year, Reason For Change, As Of Date, Valuation Method, Equalization Factor, Notice Required, Land, Improvement, Total. Rows show values for years 2025, 2024, 2023, 2022, 2021.

Land Data (Standard Depth: Res 100', CI 200' Base Lot: Res 0' X 0', CI 75' X 200')

Table with columns: Land Type, Pricing Method, Soil ID, Act Front., Size, Factor, Rate, Adj. Rate, Ext. Value, Infl. %, Market Factor, Cap 1, Cap 2, Cap 3, Value. Row 1: 11, A, 0, 0.459, 1.55, \$75,000, \$116,250, \$53,359, -15%, 1.0000, 0.00, 0.00, 100.00, \$45,350

Zoning

Subdivision

Lot

Market Model N/A

Characteristics

Topography Flood Hazard
Public Utilities ERA
Streets or Roads TIF

Neighborhood Life Cycle Stage Static

Printed Saturday, April 26, 2025

Review Group 3

Data Source N/A

Collector

Appraiser

10/2/2020 GENERAL : REASSESSMENT NO CHANGE CW

7/3/2019 GENERAL : VAILD AND SOLD FOR 125,000 ON 5/31/19 CW

10/23/2014 GENERAL : REASSESSMENT CHANGED USE TO GCR GENERAL OFFICE. REMOVED ABN OBS ON BLDG AND PAVING. JF. KH

1/31/2013 GENERAL : 13-14-bldg permit-sf/bl-changed use from gck to gen office

6/1/2012 GENERAL : REASSESSMENT-SF/KS-ADDED DET GARAGE

5/25/2010 GENERAL : 2010-11...CHANGED THE LAND INFLUENCE FROM 30% TO 15% FOR TRENDING PER KEN. CK

12/13/2001 : ADDED NEW BLDG. 91-92

Land Computations

Table with columns: Description, Value. Rows include Calculated Acreage (0.46), Actual Frontage (0), Developer Discount, Parcel Acreage (0.00), 81 Legal Drain NV (0.00), 82 Public Roads NV (0.00), 83 UT Towers NV (0.00), 9 Homesite (0.00), 91/92 Acres (0.00), Total Acres Farmland (0.00), Farmland Value (\$0), Measured Acreage (0.00), Avg Farmland Value/Acre (0.0), Value of Farmland (\$0), Classified Total (\$0), Farm / Classified Value (\$0), Homesite(s) Value (\$0), 91/92 Value (\$0), Supp. Page Land Value, CAP 1 Value (\$0), CAP 2 Value (\$0), CAP 3 Value (\$45,400), Total Value (\$45,400)

General Information

Occupancy	C/I Building	Pre. Use	General Office
Description	C/I BUILDING	Pre. Framing	Fire Resistant
Story Height	1	Pre. Finish	Finished Divided
Type	N/A	# of Units	0

SB	B	1	U
-----------	----------	----------	----------

Wall Type	1: 1(180')
Heating	1482 sqft
A/C	1482 sqft
Sprinkler	

Plumbing RES/CI

	#	TF	#	TF
Full Bath	0		0	
Half Bath	0		0	
Kitchen Sinks	0		0	
Water Heaters	0		0	
Add Fixtures	0	2	2	
Total	0	0	2	2

Roofing

<input type="checkbox"/> Built Up	<input type="checkbox"/> Tile	<input type="checkbox"/> Metal
<input type="checkbox"/> Wood	<input type="checkbox"/> Asphalt	<input type="checkbox"/> Slate
<input type="checkbox"/> Other		

GCK Adjustments

<input type="checkbox"/> Low Prof	<input type="checkbox"/> Ext Sheat	<input type="checkbox"/> Insulatio
<input type="checkbox"/> SteelGP	<input type="checkbox"/> AluSR	<input type="checkbox"/> Int Liner
<input type="checkbox"/> HGSR	<input type="checkbox"/> PPS	<input type="checkbox"/> Sand Pnl

Exterior Features

Description	Area	Value
Stoop, Masonry	35	\$1,800
Canopy, Roof Extension	35	\$800

Special Features

Description	Value	Description	Value

Other Plumbing



Floor/Use Computations

Pricing Key	GCR
Use	GENOFF
Use Area	1482 sqft
Area Not in Use	0 sqft
Use %	100.0%
Eff Perimeter	180'
PAR	12
# of Units / AC	0 / N
Avg Unit sz dpth	
Floor	1
Wall Height	8'

Base Rate	\$150.32
Frame Adj	\$0.00
Wall Height Adj	\$0.00
Dock Floor	\$0.00
Roof Deck	\$0.00
Adj Base Rate	\$150.32
BPA Factor	1.00
Sub Total (rate)	\$150.32
Interior Finish	\$0.00
Partitions	\$0.00
Heating	\$0.00
A/C	\$0.00
Sprinkler	\$0.00
Lighting	\$0.00
Unit Finish/SR	\$0.00
GCK Adj.	\$0.00
S.F. Price	\$150.32
Sub-Total	
Unit Cost	\$0.00
Elevated Floor	\$0.00
Total (Use)	\$222,774

Building Computations

Sub-Total (all floors)	\$222,774	Garages	\$0
Racquetball/Squash	\$0	Fireplaces	\$0
Theater Balcony	\$0	Sub-Total (building)	\$228,574
Plumbing	\$3,200	Quality (Grade)	\$1
Other Plumbing	\$0	Location Multiplier	0.87
Special Features	\$0	Repl. Cost New	\$188,917
Exterior Features	\$2,600		

Summary of Improvements

Description	Story Height	Constr Type	Grade	Year Built	Eff Year	Eff Co Age	nd	Base Rate	LCM	Adj Rate	Size	RCN	Norm Dep	Remain. Value	Abn Obs	PC	Nbhd	Mrkt	Cap 1	Cap 2	Cap 3	Improv Value
1: C/I BUILDING	1	3/6 Maso	C-1	2013	2013	12	A		0.87		1,482 sqft	\$188,917	14%	\$162,470	0%	100%	1.0000	0.640	0.00	0.00	100.00	\$104,000
2: Paving, Asphalt1	1	Asphalt	C	1996	1996	29	A	\$2.81	0.87	\$2.44	2,000 sqft	\$4,889	80%	\$980	0%	100%	1.0000	1.000	0.00	0.00	100.00	\$1,000