



RESIDENTIAL



UNIT 301

UNIT 201

# STR CONDO PACKAGE

888 Girod Street Units 201 & 301

New Orleans, LA, 70113



LAFAYETTE SQUARE

THE BARNETT

SALON SALON

SEAWORTHY

COMMON HOUSE  
PÉCHE  
SOFIA  
EMERIL'S  
JOLIE  
JUNEBUG

888 GIROD



6 BEDROOMS

\$2,900,000



6 FULL & 2 HALF BATHS



AVAILABLE PARKING

ENTRANCE

ROUSES' SUPERMARKET



## 3 BEDS & 3.5 BATHS PER FLOOR & A PRIVATE ELEVATOR

From the elevator, you'll step directly into each condo located in the heart of the vibrant South Market District. With award-winning restaurants, lively bars, shopping, and a full-service grocery just outside the front door, every convenience is only steps away. This historic property is permitted for short-term rentals and furniture can be made available for additional purchase. Please contact listing agents for STR income and occupancy rates.





3 BEDROOMS

**\$1,450,000**  
PER UNIT



3.5 BATHROOMS



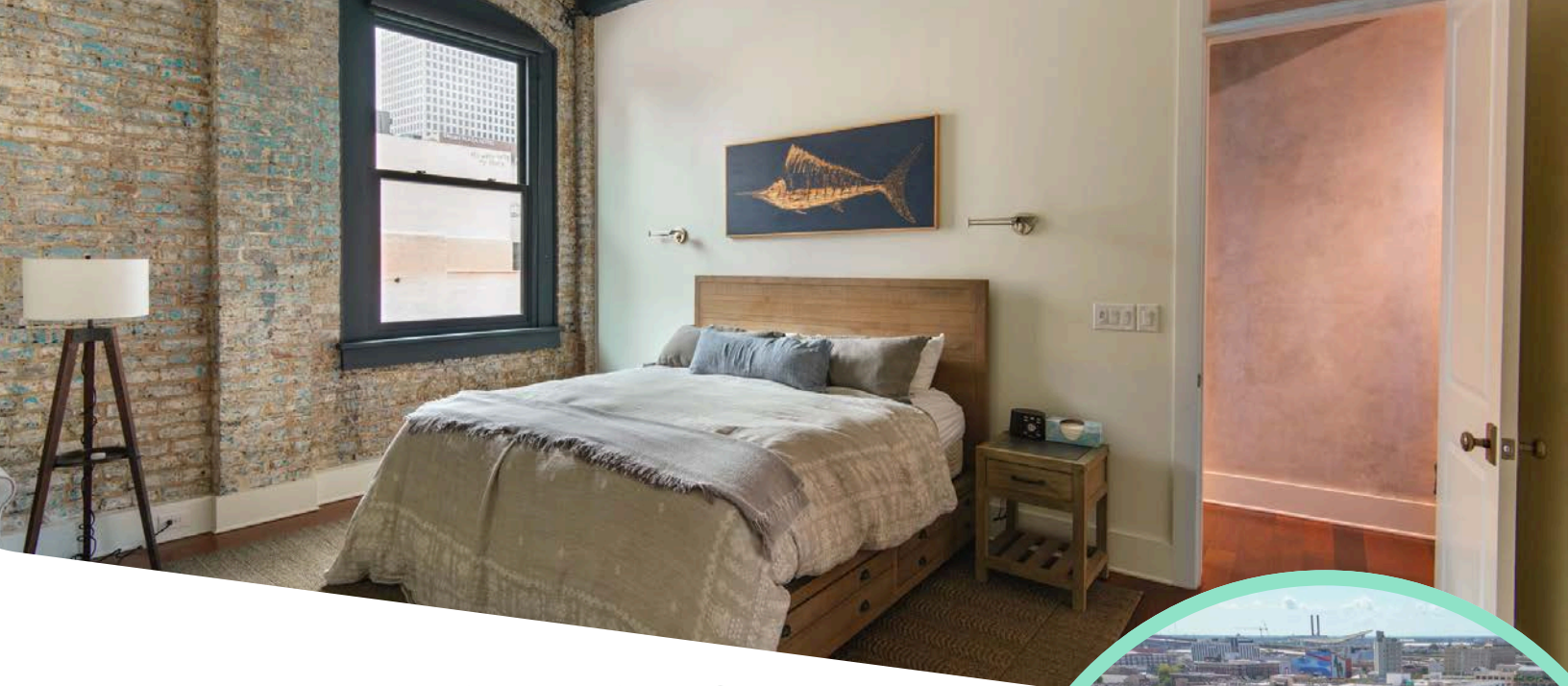

## DETAILS & HISTORY

This historic warehouse has been transformed into an upscale mixed-use property with a ground floor commercial suite and three residential units above.

Inside, exposed brick, original wood and metal beams, and large industrial windows frame a sleek, modern, industrial design, elevated with Brazilian walnut floors, marble baths, granite and marble countertops, professional grade Thermador appliances with gas cooking, two Nest thermostat controlled HVAC zones, and designer Delta and Brizo fixtures throughout.

Step outside to award-winning restaurants, bars, boutique shopping, and a full-service grocery store (across the street). Just blocks away are the Caesars Superdome, Smoothie King Center, French Quarter, and Warehouse/Arts District - with The Ogden Museum, National WWII Museum, and hundreds of restaurants and bars all within walking distance.

HOA includes exterior property and flood insurance, pest control, water, gas, fiber optic internet (1GB Speeds), security, and common area utilities/maintenance, including the elevator.

- Rare chance to STR through sites like Air-Bnb and VRBO
- Secure front entrance & private elevator
- Two blocks off the Mardi Gras parade route
- Highly energy efficient
- Fiber optic available with 1GB speed

### Neighbors less than 1 block away:

- Rouses Market - 40,000 square foot high-end grocery store
- Restaurants: Willa Jean, Seaworthy, Herbsaint, Desi Vegas, Forbidden Pizza, Pluck, and Bearcat to name a few.
- CVS and Planet Fitness

## BUILDING'S HISTORY

- Originally built around 1911, the building underwent a full transformation in 2019-2020, converting it from an industrial warehouse into a luxury mixed-use property.

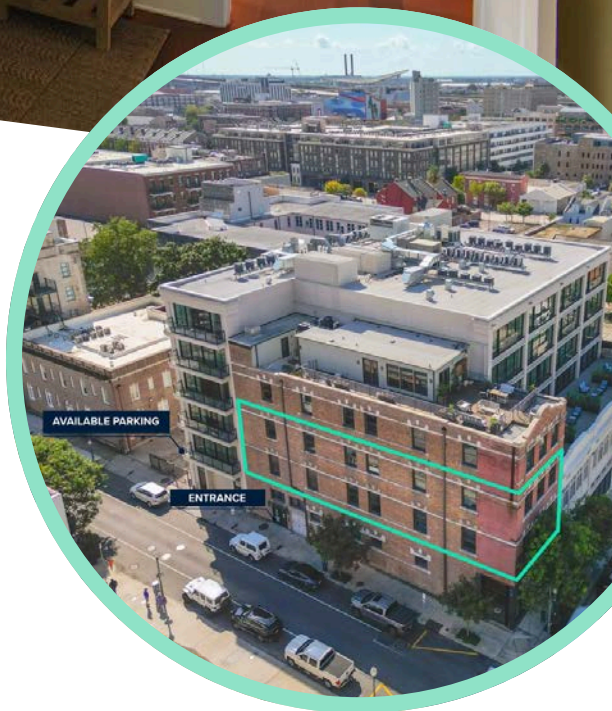

Contact Us



Cell: (414) 870-3220

[nbkallman@srsa-realestate.com](mailto:nbkallman@srsa-realestate.com)

Office: (504) 831-2363





RESIDENTIAL

# Floor Plan & Contact Info

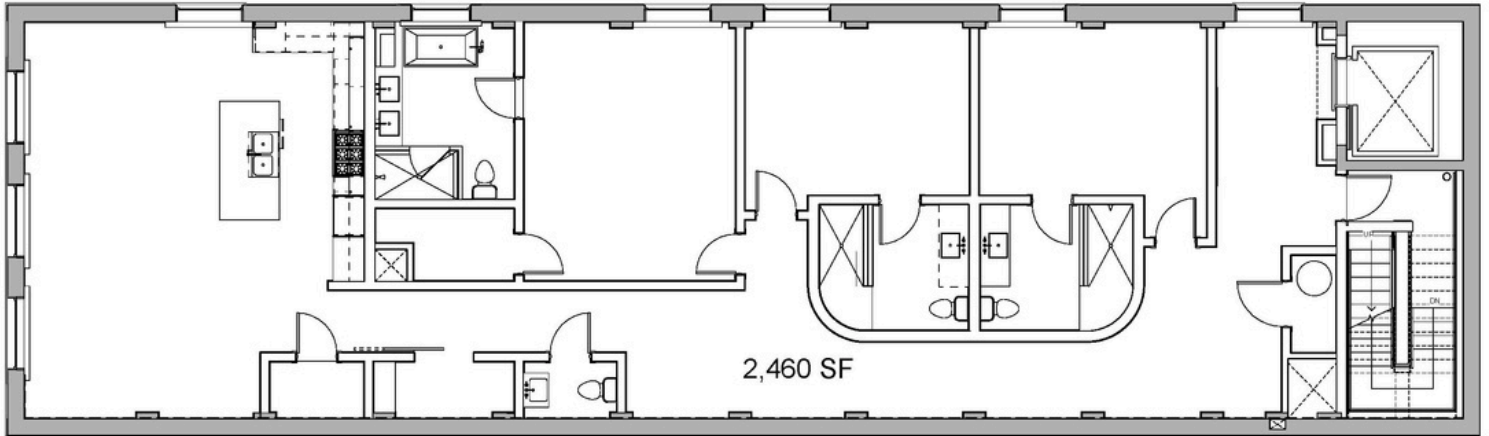

FLOOR PLANS ARE APPROXIMATE AND MEASUREMENTS AND SF ARE TO BE CONFIRMED BY THE BUYER

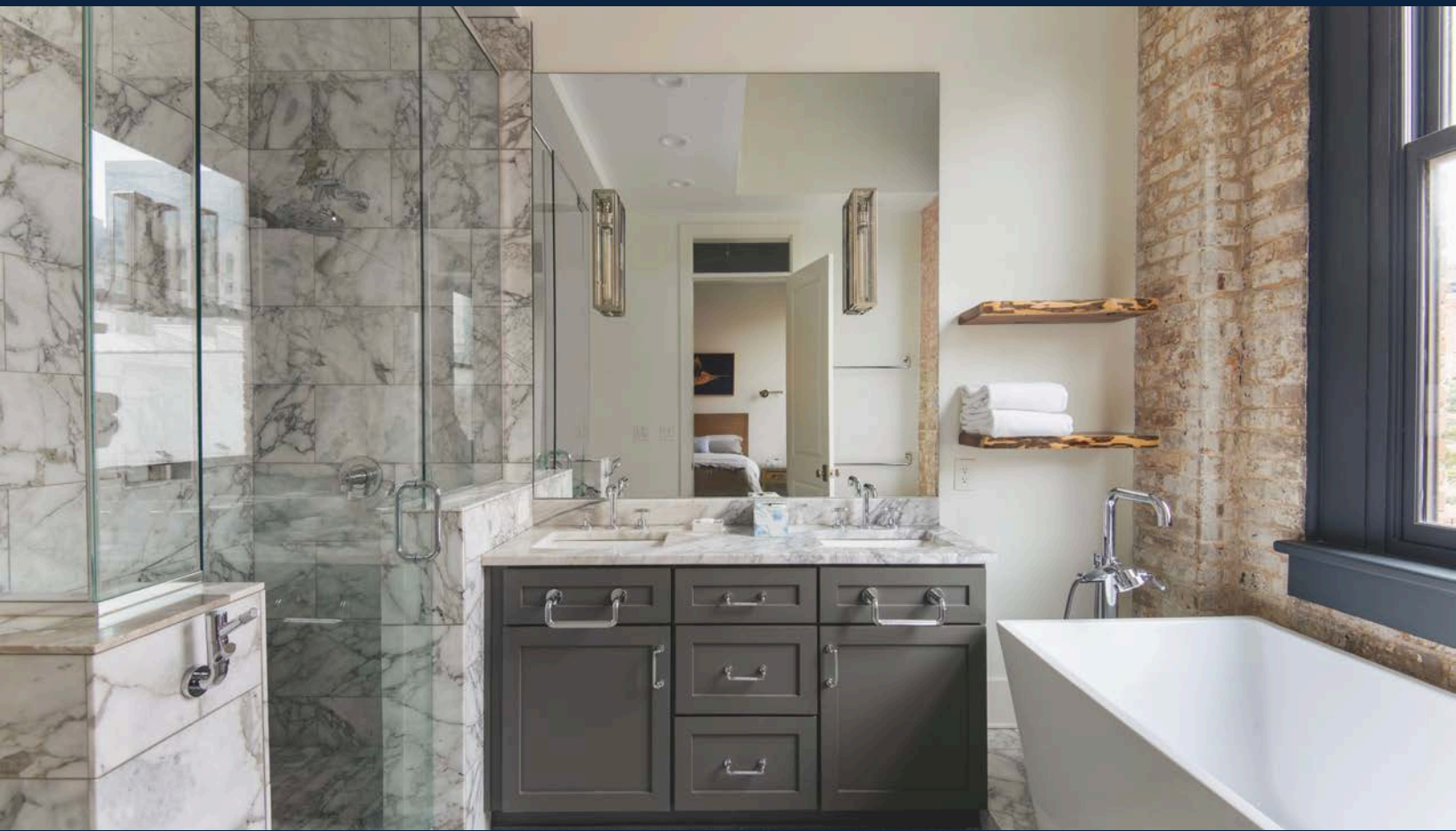

**FOR MORE INFORMATION**

**NICK B. KALLMAN**

**SRSA RESIDENTIAL**

Director of Residential Sales & Leasing

(414) 870-3220 | nbkallman@srsa-realestate.com

