

STAGE 412

Frequency-Agile, Quad-Channel Wireless System



OWNER'S MANUAL

SAMSON®

Copyright 2018, Samson Technologies Corp.
v1

Samson Technologies Corp.
278-B Duffy Ave
Hicksville, NY 11801
www.samsontech.com

Important Safety Information



ATTENTION
RISQUE DE CHOC ÉLECTRONIQUE -
NE PAS OUVRIR



This lightning flash with arrowhead symbol within an equilateral triangle is intended to alert the user to the presence of non-insulated “dangerous voltage” within the product’s enclosure that may be of sufficient magnitude to constitute a risk of electric shock.



The exclamation point within an equilateral triangle is intended to alert the user to the presence of important operating and maintenance instructions in the literature accompanying the appliance.

WARNING: TO REDUCE THE RISK OF ELECTRIC SHOCK, DO NOT REMOVE COVER (OR BACK) AS THERE ARE NO USER-SERVICEABLE PARTS INSIDE. REFER SERVICING TO QUALIFIED SERVICE PERSONNEL.

 If you want to dispose this product, do not mix it with general household waste. There is a separate collection system for used electronic products in accordance with legislation that requires proper treatment, recovery and recycling.

Private household in the 28 member states of the EU, in Switzerland and Norway may return their used electronic products free of charge to designated collection facilities or to a retailer (if you purchase a similar new one).

For Countries not mentioned above, please contact your local authorities for a correct method of disposal.

By doing so you will ensure that your disposed product undergoes the necessary treatment, recovery and recycling and thus prevent potential negative effects on the environment and human health.

Important Safety Information

FCC Rules and Regulations

Samson wireless receivers are certified under FCC Rules part 15 and transmitters are certified under FCC Rules part 74.

Licensing of Samson equipment is the user's responsibility and licensability depends on the user's classification, application and frequency selected.

NOTE: This equipment has been tested and found to comply with the limits for a Class B digital device, pursuant to part 15 of the FCC Rules. These limits are designed to provide reasonable protection against harmful interference in a residential installation. This equipment generates, uses and can radiate radio frequency energy and, if not installed and used in accordance with the instructions, may cause harmful interference to radio communications. However, there is no guarantee that interference will not occur in a particular installation. If this equipment does cause harmful interference to radio or television reception, which can be determined by turning the equipment off and on, the user is encouraged to try to correct the interference by one or more of the following measures:

- Reorient or relocate the receiving antenna.
- Increase the separation between the equipment and receiver.
- Connect the equipment into an outlet on a circuit different from that to which the receiver is connected.
- Consult the dealer or an experienced Radio/TV technician for help.

The device has been evaluated to meet general RF exposure requirement.

To maintain compliance with FCC's RF exposure guidelines, this equipment should be installed and operated with a minimum distance of 20cm between the radiator and your body.

The manufacturer is not responsible for any radio or TV interference caused by unauthorized modifications or change to this equipment. Such modifications or change could void the user's authority to operate the equipment.

This radio transmitter (identify the device by certification number or model number if Category II) has been approved by Industry Canada to operate with the antenna types listed below with the maximum permissible gain indicated. Antenna types not included in this list, having a gain greater than the maximum gain indicated for that type, are strictly prohibited for use with this device.

This device complies with Part 15 of the FCC rules and Industry Canada license-exempt RSS standard(s).

Operation is subject to the following two conditions:

- (1) this device may not cause harmful interference, and
- (2) this device must accept any interference received, including interference that may cause undesired operation.

WARNING: Changes or modifications not expressly approved by the party responsible for compliance could void the user's authority to operate the equipment.

Important Safety Information

1. Read these instructions.
2. Keep these instructions.
3. Heed all warnings.
4. Follow all instructions.
5. Do not use this apparatus near water.
6. Clean only with dry cloth.
7. Do not block any ventilation openings. Install in accordance with the manufacturer's instructions.
8. Do not install near any heat sources such as radiators, heat registers, stoves, or other apparatus (including amplifiers) that produce heat.
9. Do not defeat the safety purpose of the polarized or grounding type plug. A polarized plug has two blades with one wider than the other. A grounding type plug has two blades and a third grounding prong. The wide blade or the third prong are provided for your safety. If the provided plug does not fit into your outlet, consult an electrician for replacement of the obsolete outlet.
10. Protect the power cord from being walked on or pinched particularly at the plugs, convenience receptacles, and at the point where they exit from the apparatus.
11. Only use attachments/accessories specified by the manufacturer.
12. Use only with the cart, stand, tripod, bracket, or table specified by the manufacturer, or sold with the apparatus. When a cart is used, use caution when moving the cart/apparatus combination to avoid injury from tip-over.
13. Unplug the apparatus during lightening storms, or when unused for long periods of time.
14. Refer all servicing to qualified personnel. Service is required when the apparatus has been damaged in any way, such as power supply cord or plug is damaged, liquid has been spilled or objects have fallen into the apparatus has been exposed to rain or moisture, does not operate normally, or has been dropped.
15. This appliance shall not be exposed to dripping or splashing water and that no object filled with liquid such as vases shall be placed on the apparatus.
16. Caution-to prevent electrical shock, match wide blade plug wide slot fully insert.
17. Please keep a good ventilation environment around the entire unit.
18. The direct plug-in adapter is used as disconnect device, the disconnect device shall remain readily operable.
19. Batteries (battery pack or batteries installed) shall not be exposed to excessive heat such as sunshine, fire or the like.
20. The AC plug considered as disconnect device of adapter.



Introduction

Congratulations on purchasing the Samson Stage 412 Quad Microphone Wireless System! The Stage 412 system is the perfect solution for any application requiring four high quality, wireless microphones in an easy to use package. Featuring simple operation, with 12 available channels and infrared set for the transmitter channel, the Stage 412 can quickly be up and running out of the box. The system includes the SR412 Quad channel receiver with individual and mixed outputs. Also included are four VH12 handheld microphone transmitters.

With the Stage 412 system, you'll have great sound quality with clear reception, and the ability to walk freely around your venue. For any live sound application (karaoke, presentation, education, house of worship, etc.) the Stage 412 is the ideal tool for your Quad-performer needs. The Stage 412 provides outstanding performance and reliability.

Although this product is designed for intuitive operation, we suggest you take some time to go through these pages to learn how we've implemented a number of unique features, and to get step-by-step instructions for setting up your system. If your Stage 412 was purchased in the United States, you'll also find a warranty card enclosed—please don't forget to follow the instructions so that you can receive online technical support, and so that we can send you updated information about this and other Samson products. Also, be sure to check out our website (www.samsontech.com) for complete information about our full product line.

We recommend that you record your serial number in the space provided below, for future reference.

Serial number: _____

Date of purchase: _____

If you have any questions or comments regarding the Stage 412 Wireless System or any other products from Samson, do not hesitate to contact us at support@samsontech.com.

With proper care and maintenance, your Stage 412 will operate trouble-free for many years. Should your Stage 412 ever require servicing, a Return Authorization (RA) number must be obtained before shipping your unit to Samson. Without this number, the unit will not be accepted. Please visit www.samsontech.com/ra for an RA number prior to shipping your unit. Please retain the original packing materials and, if possible, return the unit in its original carton. If your Stage 412 was purchased outside of the United States, contact your local distributor for warranty details and service information.

Features

- Professional, Quad-handheld wireless system for use in both live sound and sound contracting applications
- 6 available frequencies per receiver channel operating in the VHF band designed for maximum system compatibility in the same location without interference
- Individual receiver (4) 1/4", mixed pair (2) XLR and all receivers mixed XLR outputs
- Up to 200' of line-of-sight operating range
- Four professional VH12 handheld transmitters with Q6 Dynamic Microphone capsules
- Up to 10 hours of battery life, using two standard AA batteries

SR412 Receiver Front Panel Features

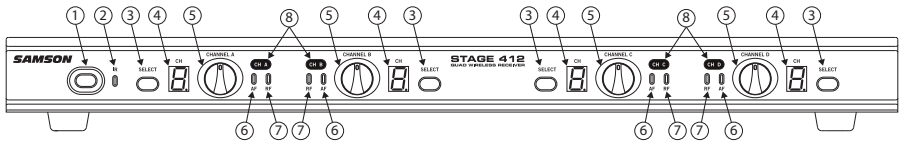

1. **Power Switch** - Press to turn the receiver on or off.
2. **IR Transmitter** - When performing an “IR SET” for any of the four receivers, an infrared light is used to set the transmitter channel.
3. **Channel SELECT Buttons** - Press this button to cycle through each of the four receiver’s operating channels. Press and hold this button to send the channel information to the transmitter via the “IR SET” infrared transmission.
4. **LED Displays** - The 7-segment LED display shows each receiver’s current operating channel. The channels are indicated by numbers 1–6.
5. **Volume Controls** - This knob sets the level of the audio signal being output through the corresponding receiver output jack on the rear panel. Reference level is obtained when the knob is turned fully clockwise (to its “10” setting).
6. **AF Indicators** - Lights green when the corresponding VH12 transmitter is powered on, and there is an audio signal present and detected by the receiver. The indicator lights red when the transmitted audio signal is overloaded.
7. **RF Indicators** - Lights orange when the corresponding VH12 transmitter is powered on, and there is an RF signal present and detected by the receiver.
8. **Channel Labels** - The channel label designates the frequency group. The label color matches the label color on the bottom of the corresponding handheld microphone transmitter.

SR412 Receiver Rear Panel Features

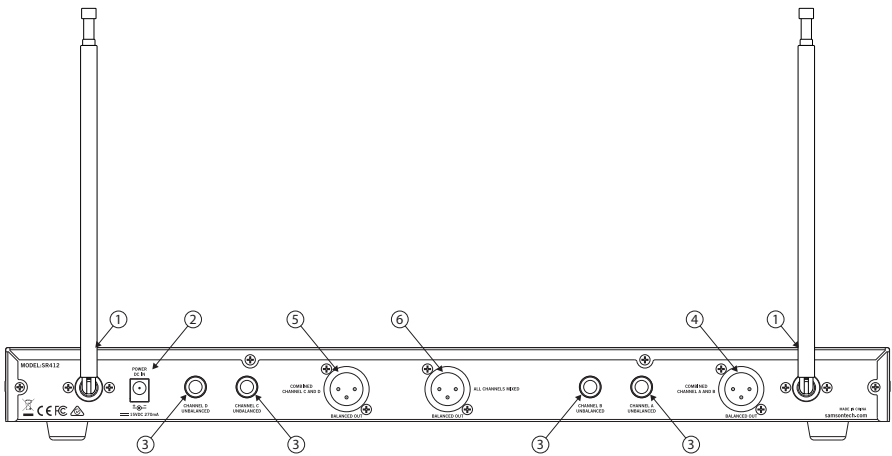

1. **Antenna** - The antenna mountings allow full rotation for optimum placement. In normal operation, both antennas should be placed in a vertical position. The antennas can be folded down for convenience when transporting the SR412.
2. **POWER DC IN** - Connect the supplied 15-volt adapter here.
WARNING: Do not substitute any other kind of power adapter. Doing so can cause damage to the SR412 and will void your warranty.
3. **Unbalanced Outputs** - Use the unbalanced, 1/4" jacks to connect the individual SR412 receivers to the line level inputs of a mixer, amplifier, or other audio equipment.
4. **CHANNELS A & B Mixed Output** - This balanced, low impedance XLR jack carries a mix of both the Channel A and Channel B receivers.
5. **CHANNELS C & D Mixed Output** - This balanced, low impedance XLR jack carries a mix of both the Channel C and Channel D receivers.
6. **MIXED OUT ALL CHANNELS** - This balanced, low impedance XLR jack carries a mix of all four receivers.

VH12 Transmitter Controls and Features

- Status Indicator** - This LED displays the operation mode:

GREEN	Normal Operation
RED	Mute
Flashing GREEN	Low Battery

- Power/Mute Switch** - Press and hold to turn the unit on or off. Press and release to mute or unmute the transmitter.

- Battery Cover** - Unscrew the battery cover and slide down to open the VH12 battery compartment.

- Battery Holder** - Open the battery holder by pressing the tab and lifting the cover. Insert two standard AA (LR6) batteries here, being sure to observe the plus and minus polarity markings shown.
WARNING: Do not insert the batteries backwards; doing so can cause severe damage to the VH12 and will void your warranty.

- Input GAIN Control** - This control adjusts the transmitter input sensitivity. For optimal performance, using the included screwdriver, set the input GAIN control to where you see the VH12 PEAK indicator start to light under high levels, then turn down until the PEAK light stops lighting.

- IR Lens** - This window is used to capture the infrared signal sent from the VH12 during the IR SET to channelize the transmitter. The battery cover must be open and the IR Lens facing towards the receiver to load the selected channel.

- Plastic Screwdriver** - Designed for use in adjusting the VH12 input GAIN control (See #5 **Input GAIN Control**).

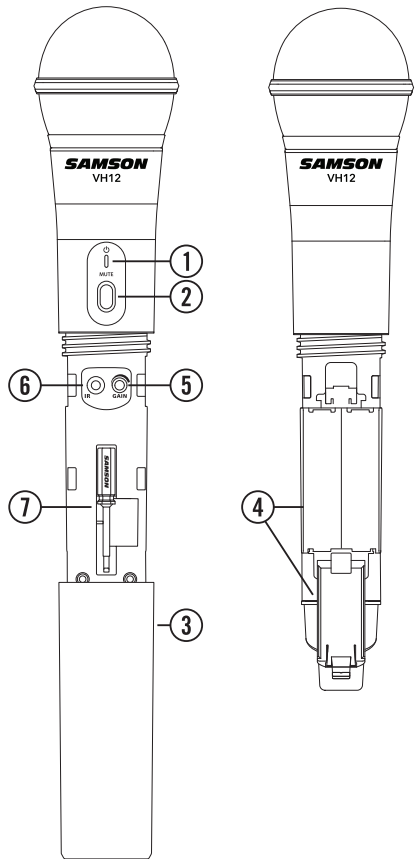

Quick Start

In order for your wireless system to work correctly, both the receiver and transmitters must be set to the same channel.

Follow this basic procedure for setting up and using your Stage 412 wireless system:

Physically place the SR412 receiver where it will be used, and fully extend the antennas vertically. The general rule of thumb is to maintain “line of sight” between the receiver and transmitter so that the person using or wearing the transmitter can see the receiver.

With the SR412 powered off, connect the included power adapter. Turn the SR412 on momentarily to confirm that the unit is receiving power. You’ll see the LED displays light up. Then turn the SR412 power off.

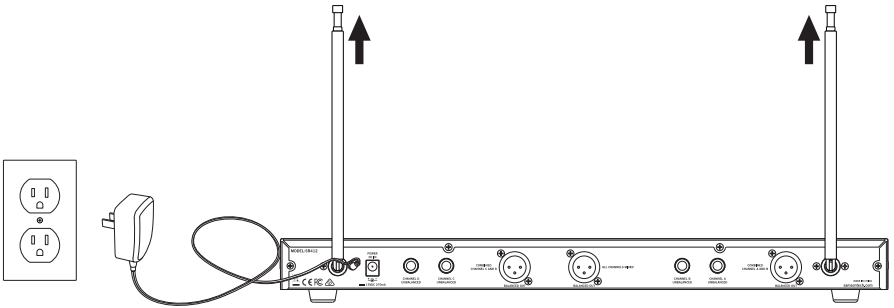

With your amplifier or mixer off and volume control all the way down, connect the SR412 receiver XLR Mix Outputs or individual receiver 1/4” outputs or to the inputs of a mixer or amplifier. Turn the Level knob on the SR412 completely counterclockwise, then turn its power on.

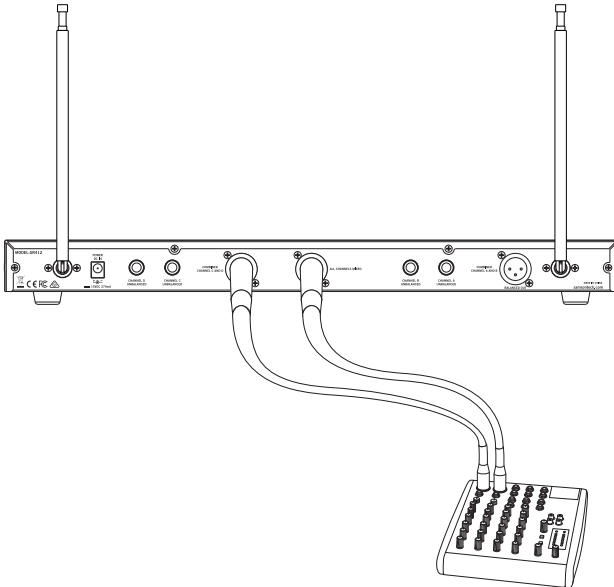

Quick Start

With the transmitter powered off, install two fresh AA batteries into VH12 handheld transmitter. Leave the battery compartment open. Turn on the power to the transmitter by pressing and holding Power switch; the indicator LED will light green.

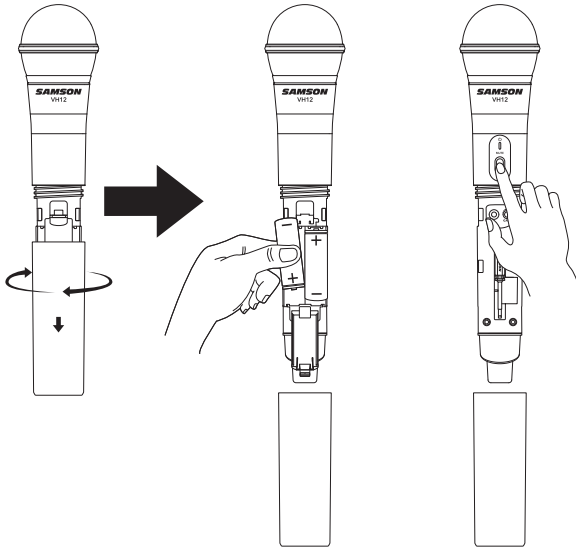

Press the CH A SELECT button on the front of the SR412 to choose an available channel for the CH A receiver. The channel number will increase by one digit, from 1–6. Once the last channel has been reached, the count will cycle back to 1.

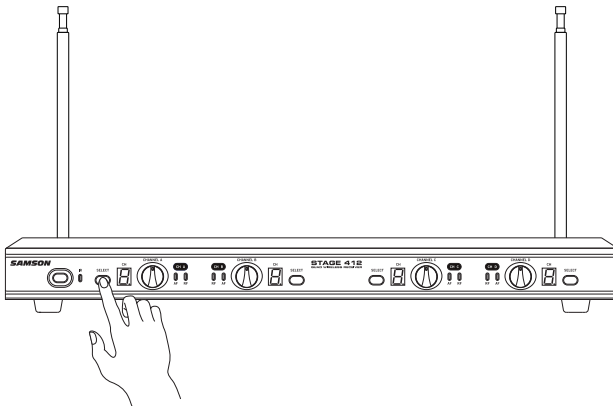

Quick Start

Position the VH12 transmitter about 6-12" (15-30 cm) from the front of the SR412 receiver with the transmitter's IR window facing the IR transmitter on the front panel of the SR412 receiver.

Press and hold the SR412 CH A SELECT button to set the transmitter to the same channel as the receiver via infrared transmission.

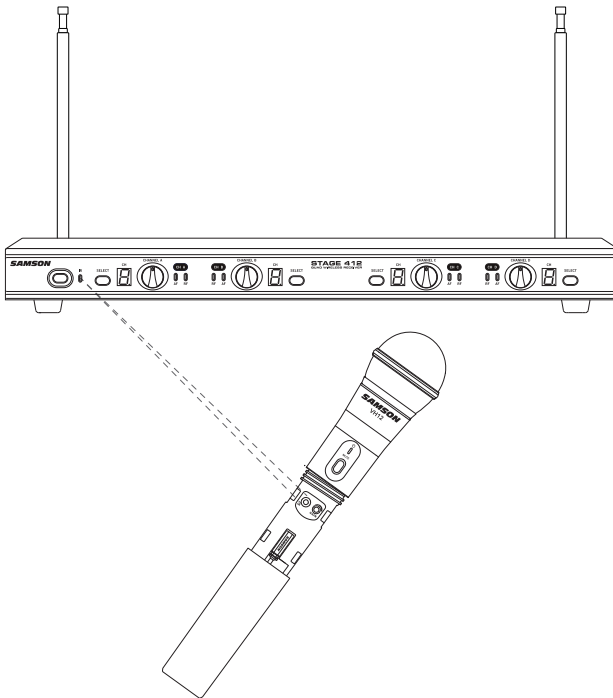

When the transmission is complete, the SR412 will receive RF signal and the tone-key (for more about tone-key read the section titled **"All about squelch"**) from the transmitter. The CH A READY indicator will light on the front panel of the SR412 receiver. Repeat these steps for the remaining transmitters and receivers. The four receivers available frequency channels do not overlap, so you can set the four receivers to the same channel number.

Turn on your connected amplifier or mixer, but keep the volume all the way down. Set the Volume knob on the SR412 fully clockwise (to its "10" setting). This is unity gain.

Speak or sing into the microphone. Slowly raise the volume of your amplifier or mixer until the desired level is reached.

If you find the system has noticeable dropouts, reduced overall working range, or unexpected noise bursts, change the operating channel of the system using the steps above.

When using multiple systems in the same frequency band, each system must be set to a different operating channel.

Specifications

System Specifications

Operating Frequency	VHF 173 MHz to 198 MHz
Number of Frequencies per Channel	6
Frequency Stability	±0.005%
Modulation Mode	FM
Maximum Deviation	±30 kHz
Operating Range	200' / 60m
Operating Temperature Range	40° to 43°
Working Humidity	65±20%RH
Frequency Response	80 Hz to 15 kHz
Tone Key Frequency	30.00 kHz

SR412 Receiver Specifications:

Image Rejection	35 dB
Dynamic Range	100 dB
Maximum Output	1.37 V
Sensitivity	-100 dBm @ 30 dB SINAD
Output Connectors	Two 1/4" (6.3 mm) unbalanced, Three XLR balanced
Audio Output Levels	-12dB
Power Supply	100-240V, 50/60Hz, 0.4A, Output: DC 15V, 800mA
Dimensions	16.92" x 6.7" x 1.57" / 430 mm x 170 mm x 40 mm
Net Weight	3.08 lb / 1.4 kg

VH12 Transmitter Specifications

RF Power Output	10mW
Microphone Element	Q6 Dynamic
Typical Battery Life	12 hours
Current Consumption	120 mA typical
Dimensions	ø2.16" x 10" / ø55 mm x 255 mm
Net Weight	0.48 lb / 0.22 kg

At Samson, we are continually improving our products, therefore specifications and images are subject to change without notice.

All about squelch

Squelch (or muting) circuitry acts to silence the audio output of the receiver whenever the desired RF signal is not present. If such circuitry is not present, the receiver may output a different signal—or even extremely unpleasant white noise—whenever the RF signal is lost due to dropout or excessive distance, or when the transmitter is turned off. This is due to a phenomenon known as the capture effect (sometimes called capture ratio), which describes the fact that an FM receiver is constantly seeking RF signal and will always utilize the strongest signal of a particular frequency that it locates (with the strongest signal always suppressing weaker signals of the same or nearly same frequency).

To combat this, there are several kinds of squelch circuits used by wireless systems. The most basic kind, called carrier squelch, simply sets an RF signal threshold; when signals drop below this threshold, the audio output is muted.

Another, more advanced design, called noise squelch, carries out an automatic comparison of the incoming RF signal to a reference voltage (generally 200 kHz or higher) in order to determine whether it is valid signal or simply radio noise (which has much greater high frequency energy than valid signal), muting the audio output when noise is detected.

A third kind is called tone squelch (sometimes called “tone-key” or “tone-code” squelching). The Stage 412 system features this method of squelch. Here, the transmitters add a supersonic tone to all audio signals they transmit, with the receivers refusing to pass through any received audio signal that does not contain this tone.

Troubleshooting

Issue	Solutions
No Audio	Turn on the VH12 transmitter using the Power/Mutr switch.
	Ensure the VH12 transmitter's batteries are installed correctly.
	Confirm that the SR412 adaptor is correctly connected and plugged into an electrical outlet.
	Turn on the SR412 receiver.
	Make sure the SR412 output and audio input connections are securely connected.
	Ensure that the SR412 receiver and VH12 transmitters are in line of sight with one another.
	Check the receiver and audio input device level controls.
Distorted Audio	Check the receiver output level and audio input device level.
	Check the VH12's batteries and replace if low.
	Another transmitter may be broadcasting on the same channel. Turn off transmitter that may be causing interference.
Audio Dropout	The transmitter may be too far away from the receiver. Move closer to the receiver, or reposition the antennas.
	Remove any sources that may cause RF interference, such as cell phones, cordless phones, lighting equipment, computers, etc.
Transmitters and Receiver on Different Channels	Contact your Samson reseller or distributor for assistance.

Samson Technologies
278-B Duffy Ave
Hicksville, NY 11801
Phone: 1-800-3-SAMSON
www.samsontech.com