

# KARA® / KARAI SYSTEM

## USER MANUAL

VERSION 3.1

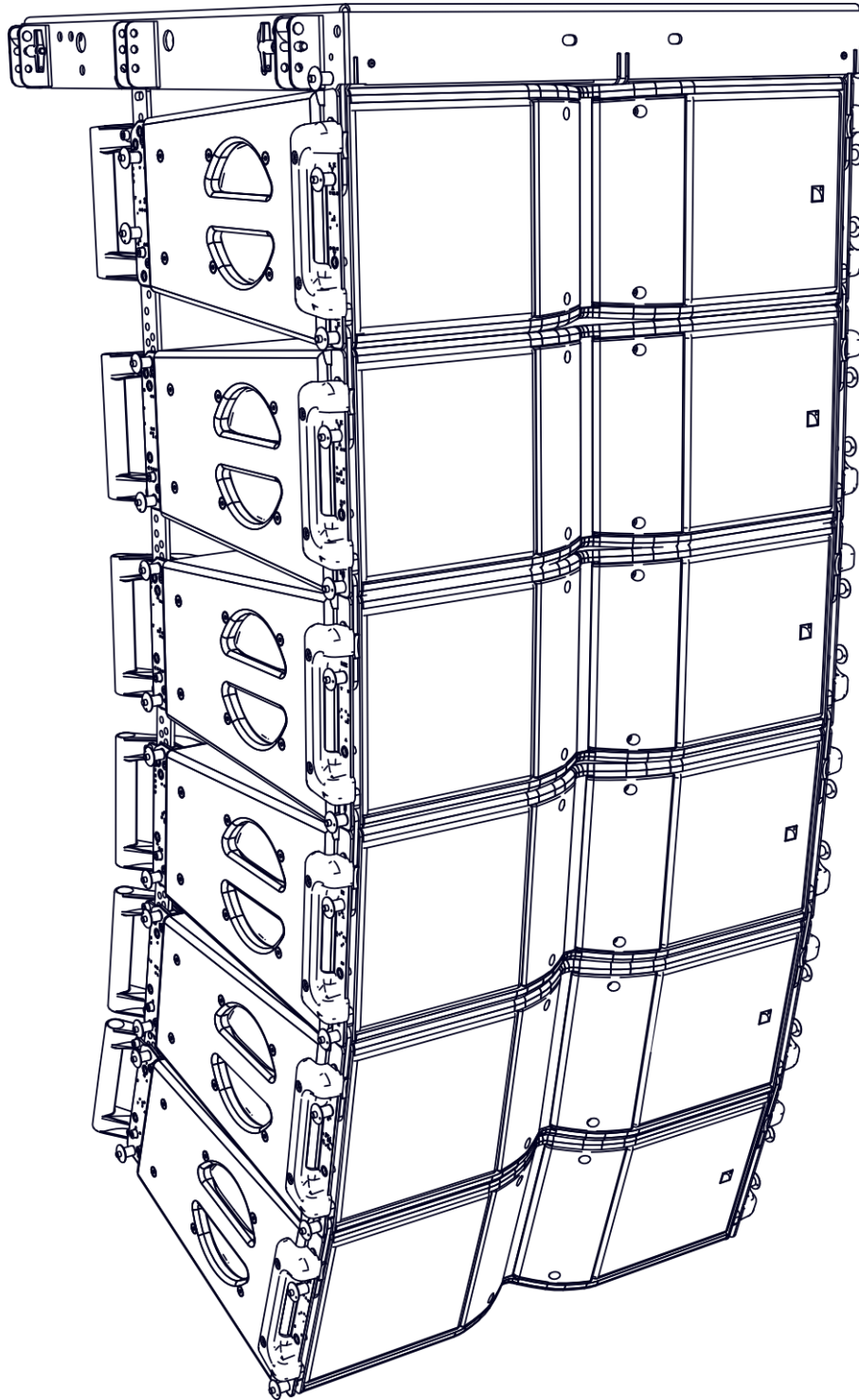

## SAFETY INSTRUCTIONS

1. **Read this manual**
2. **Follow all SAFETY INSTRUCTIONS as well as DANGER and OBLIGATION warnings**
3. **Never incorporate equipment or accessories not approved by L-ACOUSTICS®**
4. **Read all the related PRODUCT INFORMATION documents before exploiting the system**  
The product information document is included in the shipping carton of the related system component.
5. **Read the RIGGING MANUAL before installing the system**  
Use the rigging accessories described in the rigging manual and follow the associated procedures
6. **Beware of sound levels**  
Do not stay within close proximity of loudspeakers in operation and consider wearing earplugs.  
Loudspeaker systems are capable of producing very high sound pressure levels (SPL) which can instantaneously lead to permanent hearing damage to performers, production crew and audience members. Hearing damage can also occur with prolonged exposure to sound: 8 h at 90 dB(A), 30 min at 110 dB(A), less than 4 min at 130 dB(A).

## SYMBOLS

The following symbols are used in this document:



### **DANGER**

This symbol indicates a potential risk of harm to an individual or damage to the product.

It can also notify the user about instructions that must be strictly followed to ensure safe installation or operation of the product.



### **OBLIGATION**

This symbol notifies the user about instructions that must be strictly followed to ensure proper installation or operation of the product.



### **INFORMATION**

This symbol notifies the user about complementary information or optional instructions.



# WELCOME TO L-ACOUSTICS®

Thank you for choosing the L-ACOUSTICS® **KARA** or **KARAI** system.

This document contains essential information on using the system properly. Carefully read this document in order to become familiar with the system.

**As part of a continuous evolution of techniques and standards, L-ACOUSTICS® reserves the right to change the specifications of its products and the content of its document without prior notice.**

Please check the L-ACOUSTICS® web site on a regular basis to download the latest document and software updates:  
[www.l-acoustics.com](http://www.l-acoustics.com).

## CONTENTS

<b>1</b>	<b>KARA WST® SYSTEM</b>	<b>4</b>
<b>2</b>	<b>SYSTEM COMPONENTS</b>	<b>5</b>
2.1	Loudspeaker enclosure .....	5
2.2	Powering and driving system.....	5
2.3	Loudspeaker cables .....	5
2.4	Rigging element .....	5
2.5	Software application.....	5
<b>3</b>	<b>LOUDSPEAKER CONFIGURATIONS</b>	<b>7</b>
3.1	Line source .....	7
3.2	Line source with low-frequency element.....	8
3.3	Line source element.....	11
<b>4</b>	<b>LOUDSPEAKER CONNECTION</b>	<b>12</b>
4.1	Connectors .....	12
4.2	Connecting KARA to LA8.....	13
4.3	Connecting SB18 to LA8 .....	16
4.4	Connecting SB28 to LA8 .....	18
4.5	Connecting KARA to LA4X.....	20
4.6	Connecting SB18 to LA4X .....	21
<b>APPENDIX A</b>	<b>PRESET DESCRIPTION</b>	<b>22</b>
<b>APPENDIX B</b>	<b>RECOMMANDATION FOR SPEAKER CABLES</b>	<b>23</b>
<b>APPENDIX C</b>	<b>SPECIFICATIONS</b>	<b>24</b>

## 1 KARA WST® SYSTEM

With a design inspired from the KI stadium system, the KARA WST® system is the high-end modular line source from L-ACOUSTICS®. Utilizing the unrivalled characteristics of WST® (Wavefront Sculpture Technology), the KARA system delivers clarity, precision, and a unique proximity effect, for the audience to enjoy an incomparable listening experience.

The main system components are as follows:

- KARA, full-range element, operating from 55 Hz to 20 kHz;
- SB18, low-frequency element, operating down to 32 Hz;
- LA-RAK, touring rack fitted with three LA8 amplified controllers;
- LA4X amplified controller

The KARA delivers a considerable number of improvements over the previous generation of line sources, particularly with regard to directivity control in the horizontal plane, transducers resources for increased operating bandwidth and coherence, vertical coverage capability and extensive choice of operating modes to accommodate various LF contour requirements.

The compact size and low weight of a KARA line source complies with rigging and visual limitations. Any on-site deployment can be easily and quickly achieved thanks to an extremely ergonomic rigging system.

A wide range of system configurations are available for the sound designer and system engineer, allowing high level of creative freedom. With a fixed horizontal directivity of 110° and a vertical inter-element variation from 0° to 10°, the KARA line source is fully configurable to match any audience geometry. The KARA system can be deployed either as a main system (FOH or distributed) with the SB18 subwoofer, as a compact complementary system (delays or fills), and even as a dedicated KI downfill extension for stadium and arena concert applications. Before installation, these configurations can be acoustically and mechanically modeled with the SOUNDVISION 3D simulation software.

As a distribution platform for power, audio signals and network, the LA-RAK touring rack fitted with three LA8 amplified controllers is the heart of the system. Thanks to dedicated factory presets, it constitutes an extremely advanced and precise drive system for the enclosures. In high-end installation projects, the LA4X amplified controller can deliver maximum power headroom and the best possible performances. With one transducer section per output channel and the independent DSP treatment of each loudspeaker enclosure, this approach brings maximum discretization with a one-to-one-to-one link, from input-to-processing-to-enclosure. All L-ACOUSTICS amplified controllers feature the L-DRIVE, a thermal and over-exursion protection circuit.

Up to 253 LA8 amplified controllers can be connected together via the Ethernet-based L-NET protocol. The LA NETWORK MANAGER software allows online remote control and monitoring of all the connected units, via a user-friendly and intuitive graphic interface, and features the Array Morphing EQ. This exclusive tool allows the engineer to quickly adjust the tonal balance of the system to reach a reference curve or to ensure consistency of the sonic signature.



### **KARA® SYSTEM and KARAI SYSTEM**

In this document, the KARA term and illustration will refer equally to KARA® or KARAI. In the same way, the SB18 term and illustration will refer equally to SB18 or SB18i. These products are different versions of the same enclosure and share the same operating modes, presets and recommended configurations. The rigging system of each version has been designed to accommodate a different use. KARA and SB18 are optimized for touring market, whereas KARAI and SB18i are optimized for fixed installation.

## 2 SYSTEM COMPONENTS

The system approach developed by L-ACOUSTICS® consists in offering a global solution that guarantees the highest and most predictable level of performance at any step of loudspeaker system deployment: modeling, installation, and operation. A complete L-ACOUSTICS® system includes enclosures, amplified controllers, cables, rigging system, and software applications.

### 2.1 Loudspeaker enclosure

**KARA** Full-range enclosure (50 Hz – 20 kHz), 2-way active, variable curvature WST® line source

**SB18** High power compact subwoofer (down to 32 Hz)

**SB28** Subwoofer (down to 25 Hz).



#### Loudspeaker system design

Sound design aspects are beyond the scope of this document. However, the various applications of the system will be based on the loudspeaker configurations presented in this document.

### 2.2 Powering and driving system

**LA4X, LA8 or LA-RAK** Amplified controllers with DSP, preset library and networking capabilities



#### Operating instructions

Refer to the **LA4X, LA8** and **LA-RAK user manuals**.

### 2.3 Loudspeaker cables

<b>DO cables</b> (DO.7, DO10, DO25)	8-point PA-COM® loudspeaker cables (4 mm <sup>2</sup> section). Respective lengths of 0.7 m/2.3 ft, 10 m/32.8 ft, and 25 m/82 ft.
<b>DOFILL-LA8</b>	Breakout cable for two 2-way active enclosures (4 mm <sup>2</sup> section). PA-COM® < 2 x SpeakON®.
<b>DO3WFILL</b>	Breakout cable for one 2-way active enclosure and two passive enclosures (4 mm <sup>2</sup> section). PA-COM® < 3 x SpeakON®
<b>DOSUB-LA8</b>	Breakout cable for four passive enclosures. 8-point PA-COM® to 4 × 2-point SpeakON® (4 mm <sup>2</sup> section).
<b>SP cables</b> (SP.7, SP5, SP10, SP25)	4-point SpeakON® loudspeaker cables (4 mm <sup>2</sup> section). Respective lengths of 0.7 m/2.3 ft, 5 m/16.4 ft, 10 m/32.8 ft and 25 m/82 ft.
<b>SP-YI</b>	Breakout cable for two passive enclosures. 4-point SpeakON® to 2 × 2-point SpeakON® (2.5 mm <sup>2</sup> section). Provided with CC4FP adapter.



Information about the connection of the enclosures to the LA amplifiers is given in this document. Refer to the **LA4X, LA8** and **LA-RAK user manuals** for detailed instructions about the whole cabling scheme, including modulation cables and network.

### 2.4 Rigging element



Rigging elements or procedures are not presented in this document. According to the enclosure version, refer to the **KARA®** or **KARAI SYSTEM rigging manuals**.

### 2.5 Software application

**SOUNDVISION** Proprietary acoustical and mechanical 3D modeling software.

**LA NETWORK MANAGER** Remote control and monitoring of amplified controllers



#### Using L-ACOUSTICS® software

Refer to the **SOUNDVISION user manual** and the **LA NETWORK MANAGER tutorial**.

# KARA® / KARAI SYSTEM

## USER MANUAL

VERSION 3.1



KARA



SB18



SB28



LA4X



LA8



LA-RAK



DOFILL-LA8



DO.7



SPY1



DOSUB-LA8



DO10



SP.7



DO3WFILL



DO25



SP5



SP10



SP25



Soundvision



LA Network Manager

**KARA system components** (excluding rigging elements and modulation cables)

### 3 LOUDSPEAKER CONFIGURATIONS

#### 3.1 Line source

Deployed as a standalone line source, a KARA system operates over the nominal bandwidth of the KARA enclosure.

The [KARA] preset allows for a reference frequency response in long throw applications.

The KARA enclosure can be driven by the LA4X or LA8 amplified controllers.

#### Standalone KARA line source

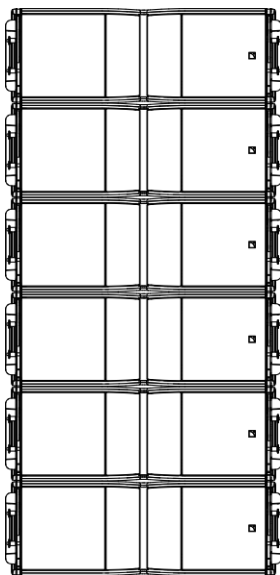

Enclosure | [PRESET]  
KARA | ► [KARA]

Frequency range (-10 dB)

55 Hz – 20 kHz

# KARA® / KARAI SYSTEM

## USER MANUAL

VERSION 3.1

### 3.2 Line source with low-frequency element

In this configuration, a KARA line source deployed with SB18 or SB28 subwoofers, the system bandwidth is extended in the low-end.

The [KARA] preset allows for a reference frequency response in long throw applications.

The [SB\*\*\_60] or [SB\*\*\_100] presets provide the SB\*\* with an upper frequency limit at 60 Hz in separated configuration, or 100 Hz in closely coupled configuration, for an optimal frequency coupling with the KARA line source.

The KARA and SB18 enclosures can be driven by the LA4X or LA8 amplified controller.

The SB28 enclosure is exclusively driven by the LA8 amplified controller.

**KARA line source + coupled SB18 or SB28**

Flown KARA array  
beside flown SB18 array

Flown or ground-stacked  
KARA/SB18 array

KARA array  
stacked on SB28

Maximum distance between arrays: **0,95 m**      Maximum number of enclosures in mixed lines: **9 KARA + 3 SB\*\***

<u>Recommended ratio</u>	<u>Enclosure</u>	<u>[PRESET]</u>	<u>Frequency range (-10 dB)</u>
3 KARA: 1 SB**	KARA	▶ [KARA]	32Hz – 20kHz with SB18
	SB18 or SB28	▶ [SB**_100]	25Hz – 20kHz with SB28

**!** Do not forget to add the **pre-alignment and geometric delays** depending on the deployment

<b>Pre-alignment delays</b>	SB18	[KARA]	[SB18_100]	KARA = 0	SB18 = 0
	SB18	[KARA]	[SB18_100]	KARA = 0	SB18 = 0
	SB28	[KARA]	[SB28_100]	KARA = 0	SB28 = 1.35

**!** Use [SB\*\*\_100\_C] with a SB subwoofer array in cardioid configuration

The cardioid configuration consists in reversing 1 element in an array of 4 subwoofers. Refer to the SB\*\* **user manual** for details about the CARDIOID mode.

<b>Pre-alignment delays</b>	SB18	[KARA]	[SB18_100_C]	KARA = 5.5	SB18 = 0
	SB28	[KARA]	[SB28_100_C]	KARA = 4.2	SB18 = 0



## KARA line source + separated SB18 or SB28

Flown KARA array with ground-stacked SB18

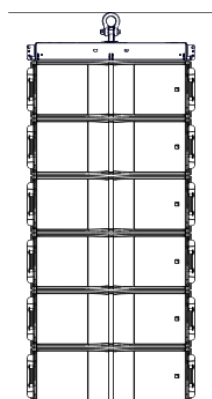

Flown KARA array with ground-stacked SB28

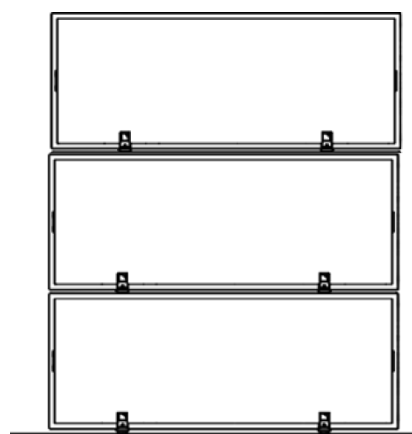
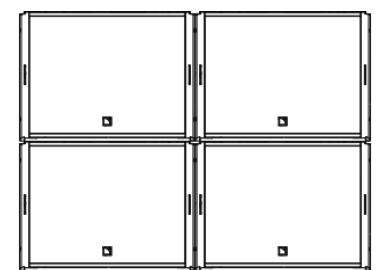
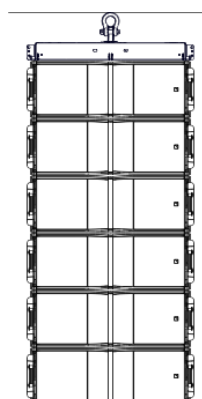

### Recommended ratio

3 KARA: 2 SB18  
2 KARA: 1 SB28

### Enclosure

KARA  
SB18 or SB28

### [PRESET]

▶ [KARA]  
▶ [SB××\_60]

### Frequency range (-10 dB)

32Hz – 20kHz with SB18  
25Hz – 20kHz with SB28



Do not forget to add the **pre-alignment and geometric delays** depending on the deployment

<b>Pre-alignment delays</b>	SB18	[KARA] + [SB18_60]	KARA = 2.5	SB18 = 0
	SB28	[KARA] + [SB28_60]	KARA = 0.3	SB28 = 0



### **Use [SB××\_60\_C] with a SB subwoofer array in cardioid configuration**

The cardioid configuration consists in reversing 1 element in an array of 4 subwoofers.  
Refer to the SB×× **user manual** for details about the CARDIOID mode.

<b>Pre-alignment delays</b>	SB18	[KARA] + [SB18_60_C]	KARA = 8	SB18 = 0
	SB28	[KARA] + [SB28_60_C]	KARA = 5.9	SB18 = 0

### KARA line source + coupled SB18 + separated SB28

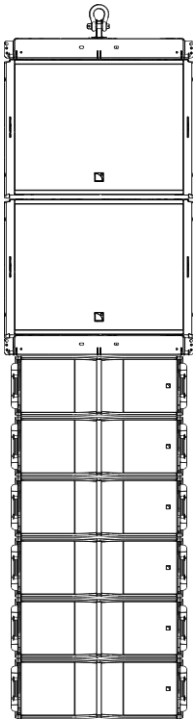

#### Recommended ratio

3 KARA : 1 SB18 : 1 SB28

#### Maximum number of enclosures

9 KARA + 3 SB18

#### Maximum distance between KARA and SB18 array

0,95 m

#### Enclosure | [PRESET]

KARA	▶	[KARA]
SB18	▶	[SB18_100]
SB28	▶	[SB28_60]

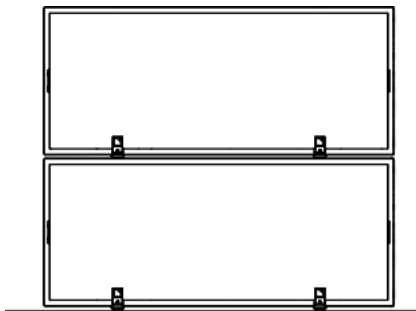

#### Frequency range (-10 dB)

32Hz – 20kHz with SB18

25Hz – 20kHz with SB28



Do not forget to add the **pre-alignment and geometric delays** depending on the deployment

**Pre-alignment delays** [KARA] + [SB18\_100] + [SB28\_60]    KARA = 0    SB18 = 0    SB28 = 1.3



**Use [SB28\_60\_C] with a SB subwoofer array in cardioid configuration**

The cardioid configuration consists in reversing 1 element in an array of 4 subwoofers.

Refer to the **SB28 user manual** for details about the CARDIOID mode.

**Pre-alignment delays** [KARA] + [SB18\_100] + [SB28\_60\_C]    KARA = 4.2    SB18 = 4.2    SB28 = 0

### 3.3 Line source element

Deployed as a line source element, a KARA system operates without the low-end of the bandwidth.

The [KARA\_FI] preset provides a flat frequency response for short throw applications and a high-pass filter at 100 Hz.

The KARA enclosure can be driven by the LA4X or LA8 amplified controllers.

#### One or two KARA enclosures

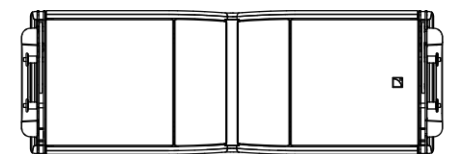

<u>Enclosure</u>	<u>[PRESET]</u>
KARA	▶ [KARA_FI]

Frequency range  
100 Hz - 20 kHz

## 4 LOUDSPEAKER CONNECTION

### 4.1 Connectors

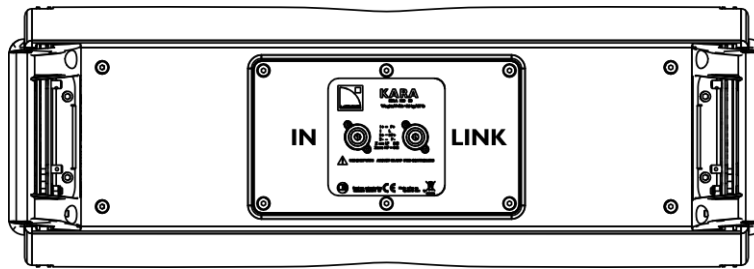

**KARA**

The KARA enclosure is equipped with two 4-point SpeakON® connectors wired in parallel.

The IN connector allows receiving the audio signals, whereas the LINK connector allows routing them to another similar enclosure in parallel.



#### Internal pinout for L-ACOUSTICS® KARA enclosures

<b>PA-COM® points</b>	I +	I -	2 +	2 -
<b>Transducer connectors</b>	LF +	LF -	HF +	HF -

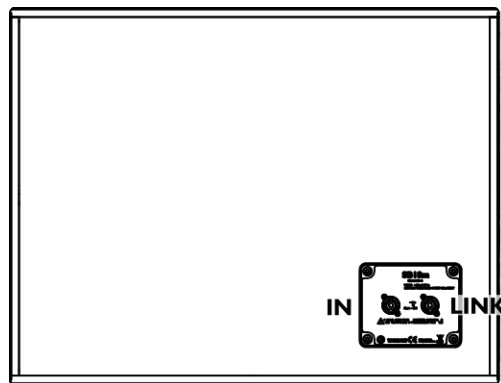

**SB18**

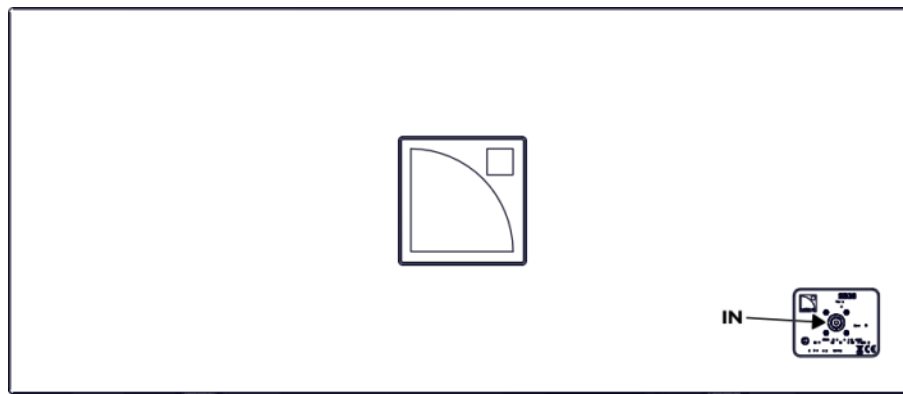

**SB28**

The KI-SB and SB28 are equipped with one 4-point SpeakON® connector.



#### Internal pinout for L-ACOUSTICS® SB18, SB18i and SB28 enclosures

<b>SpeakON® points</b>	I +	I -	2 +	2 -
<b>Transducer connectors</b>	LF +	LF -	Not used	Not used

## 4.2 Connecting KARA to LA8



### Maximum of 6 enclosures per LA8

3 KARA enclosures can be connected in parallel to each pair of output channels on the LA8 (1/2 and 3/4).



### Impedance load

1 enclosure 8  $\Omega$

2 enclosures 4  $\Omega$

3 enclosures 2.7  $\Omega$

### Option A

- ▶ Connect a **DO** cable (DO.7, DO10 or DO25) to the LA8 PA-COM<sup>®</sup> connector.
- ▶ Use a **DOFILL-LA8** to split the signal into two channel pairs each one feeding one enclosure.
- ▶ Use **SP** cables to connect additional similar enclosures in parallel with the first ones.

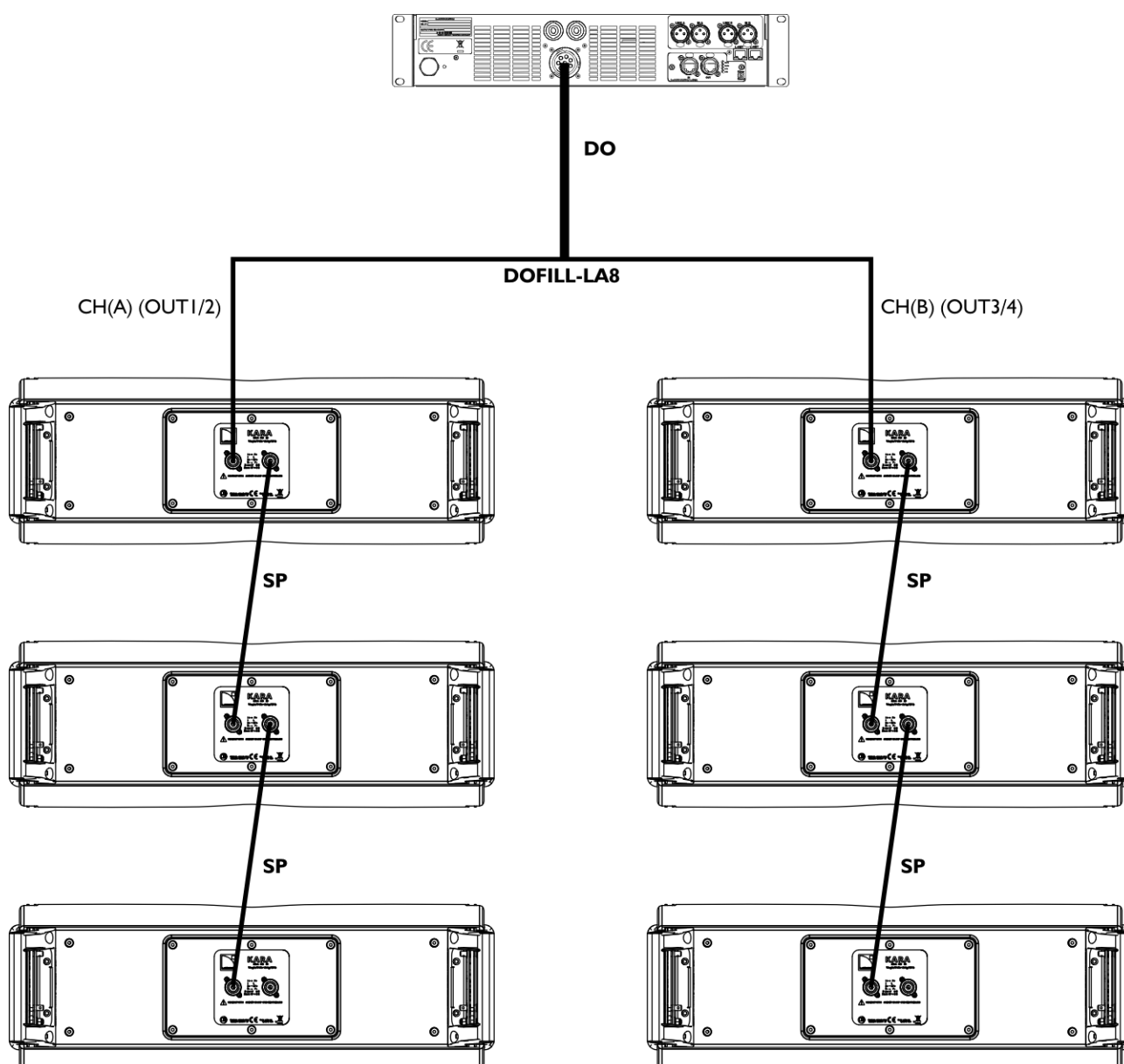

# KARA® / KARAI SYSTEM

## USER MANUAL

VERSION 3.1

### Option B

- ▶ Use an **SP** cable (SP5, SP10 or SP25) to connect one enclosure to each of the LA8 SpeakON® connectors.
- ▶ Use **SP** cables to connect additional similar enclosures in parallel with the first ones.

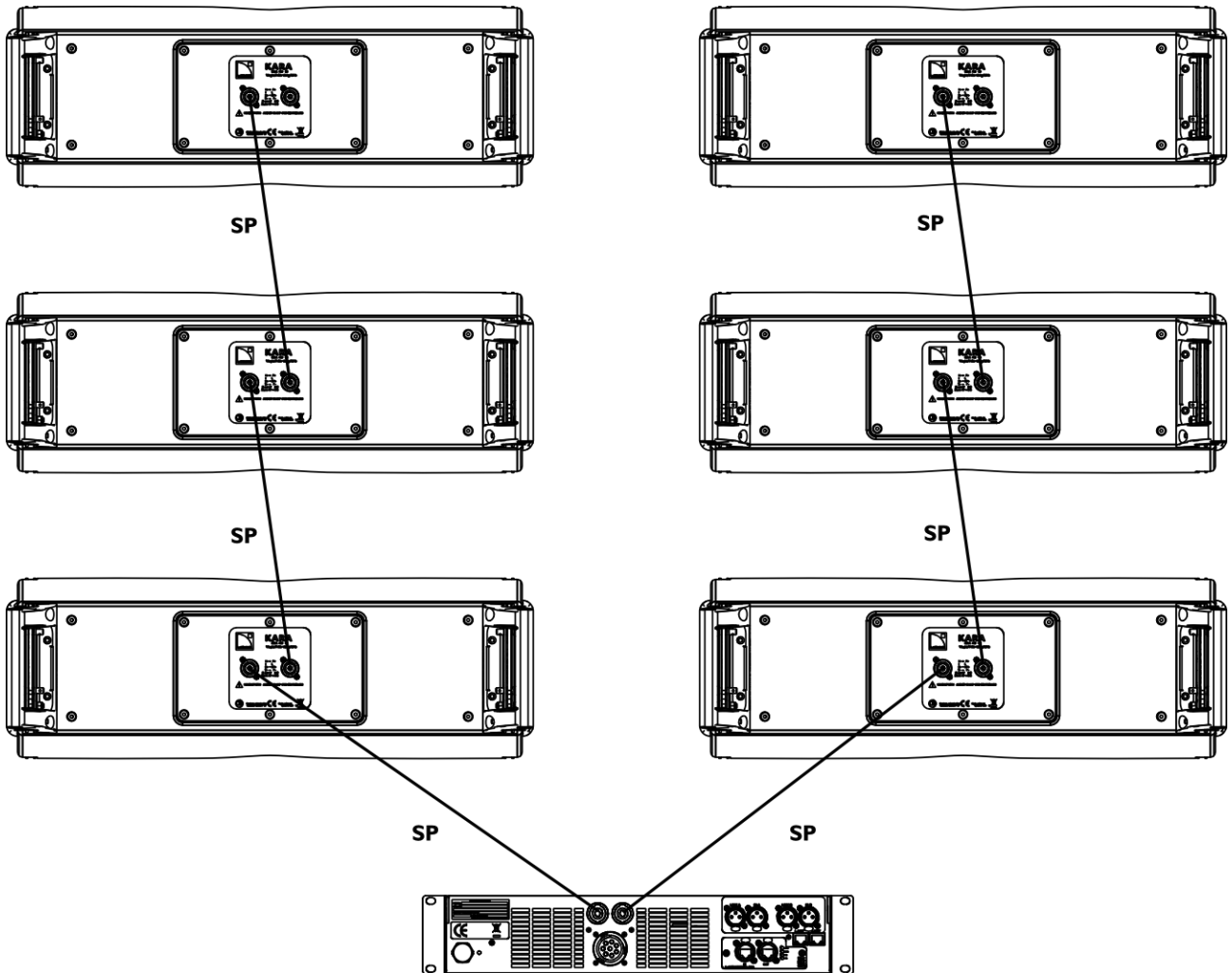

### Option C

**!** This cabling scheme requires a custom preset.

- ▶ Connect a **DO** cable (DO.7, DO10 or DO25) to the LA8 PA-COM® connector.
- ▶ Use a **DO3WFILL** to split the signal into one channel pair (**2WAY**) and two single channels (**SUB1** and **SUB2**).
- ▶ Connect the **2WAY** connector to the IN connector of the active enclosure.
- ▶ Connect the **SUB1** and **SUB2** connectors to the IN connector of the subwoofers.
- ▶ Use **SP** cables to connect additional similar enclosures in parallel with the first ones.

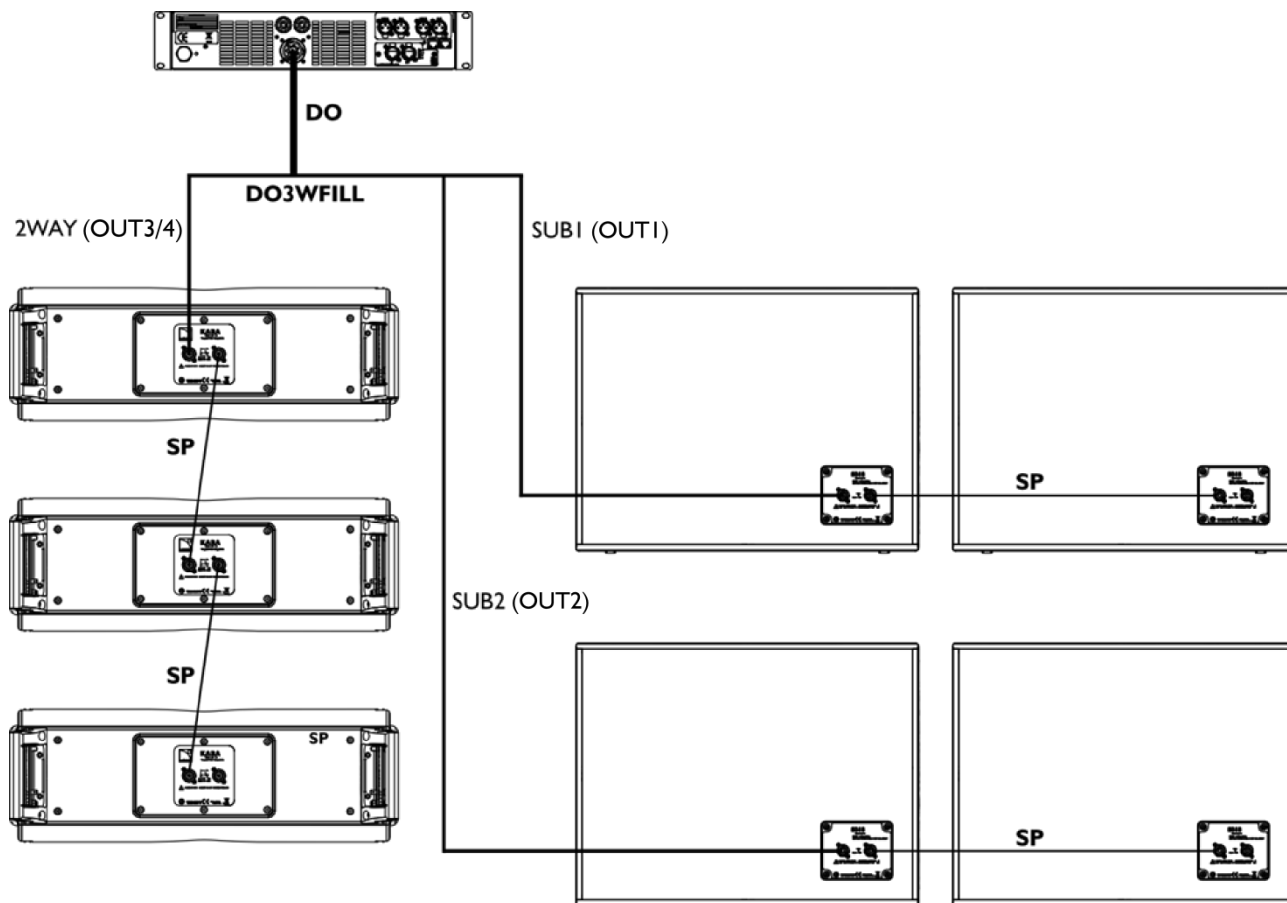

### 4.3 Connecting SB18 to LA8



#### Maximum of 8 enclosures per LA8

2 SB18 can be connected to each output channel on the LA8.



#### CARDIOID mode with SB18

Connect the reversed subwoofer to OUT 1.



#### Impedance load

1 enclosure 8 Ω

2 enclosures 4 Ω

#### Option A

- ▶ Connect a **DO** (DO.7, DO10 or DO25) cable to the LA8 PA-COM® connector.
- ▶ Use the **DOSUB-LA8** to split the audio signals into four channels, each one feeding one subwoofer.
- ▶ Use **SP** cables to connect additional similar enclosures in parallel with the first ones.



#### Corresponding DOSUB-LA8 SpeakON® points and LA8 output channels:

SPK1 = OUT 1

SPK3 = OUT 3

SPK2 = OUT 2

SPK4 = OUT 4

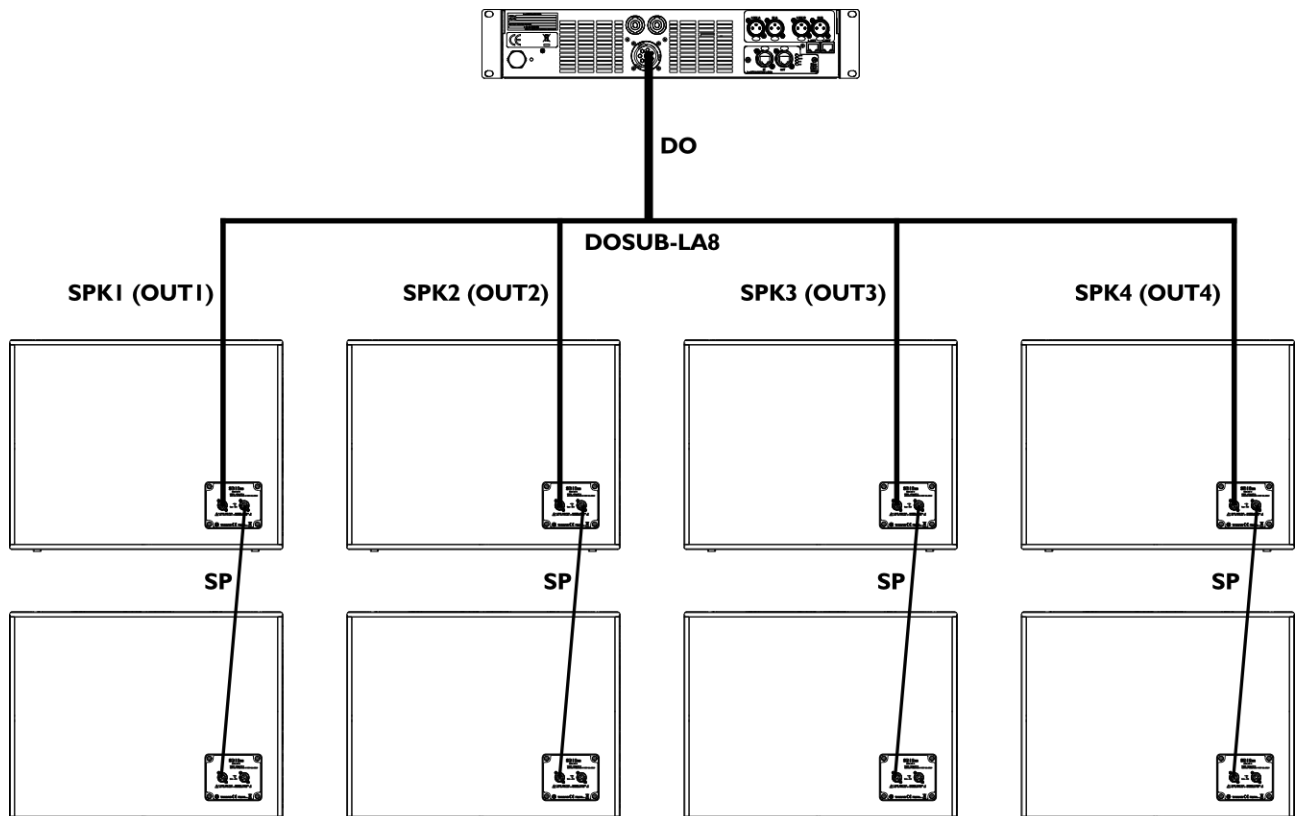



### Option B

- ▶ Connect one SP cable (SP.7, SP5, SP10 or SP25) to both LA8 SpeakON® connectors.
- ▶ Use an **SP-YI** cable and a **CC4FP** adapter to split the audio signals into two channels, each one feeding one subwoofer.

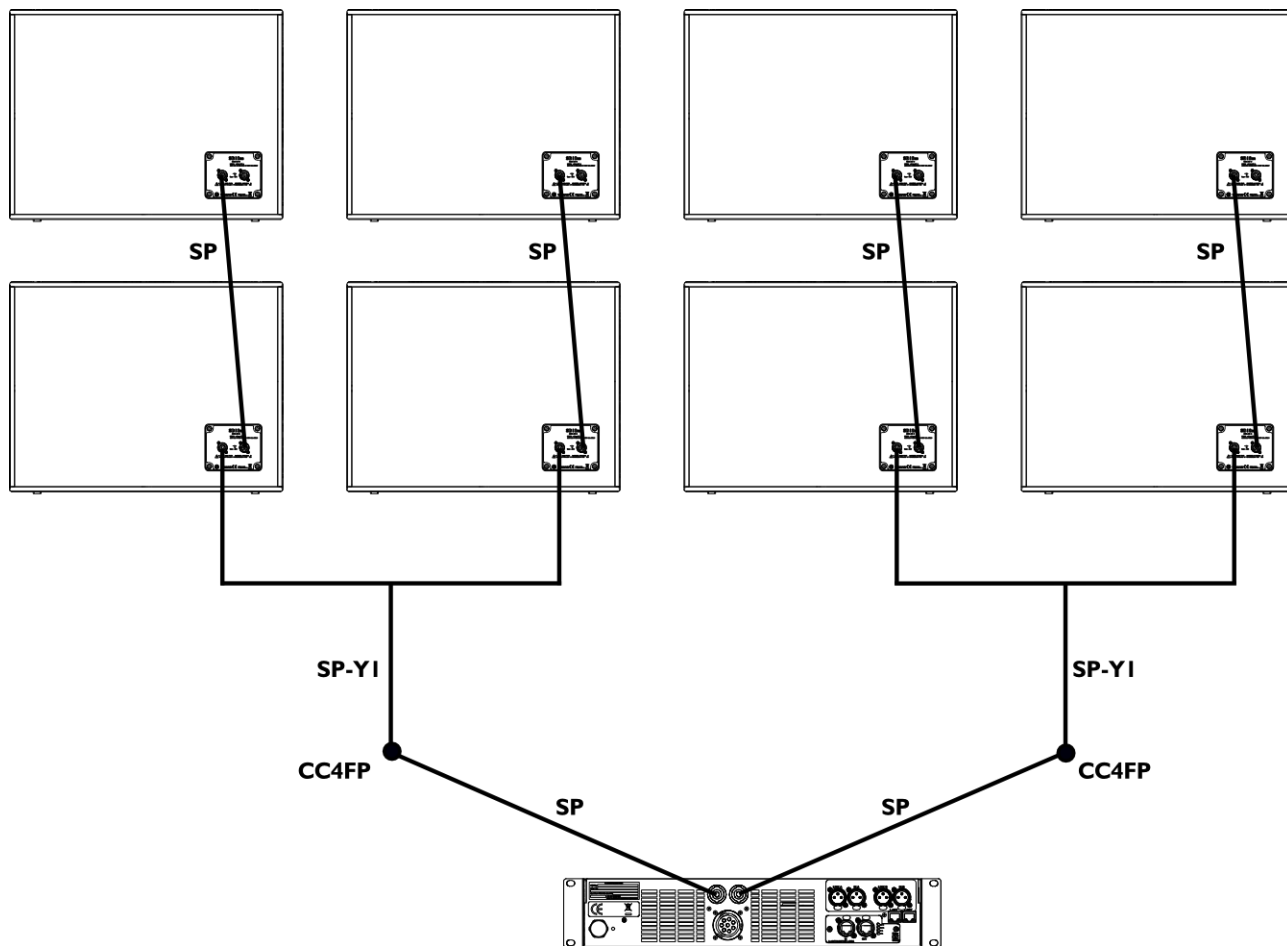

# KARA® / KARAI SYSTEM

## USER MANUAL

VERSION 3.1

### 4.4 Connecting SB28 to LA8



#### Maximum of 4 enclosures per LA8

1 SB28 can be connected to each output channel on the LA8.



#### CARDIOID mode with SB28

Connect the reversed subwoofer to OUT 1.



#### Impedance load

1 enclosure 4 Ω

#### Option A

- ▶ Connect a **DO** (DO.7, DO10 or DO25) cable to the LA8 PA-COM® connector.
- ▶ Use the **DOSUB-LA8** to split the audio signals into four channels, each one feeding one subwoofer.

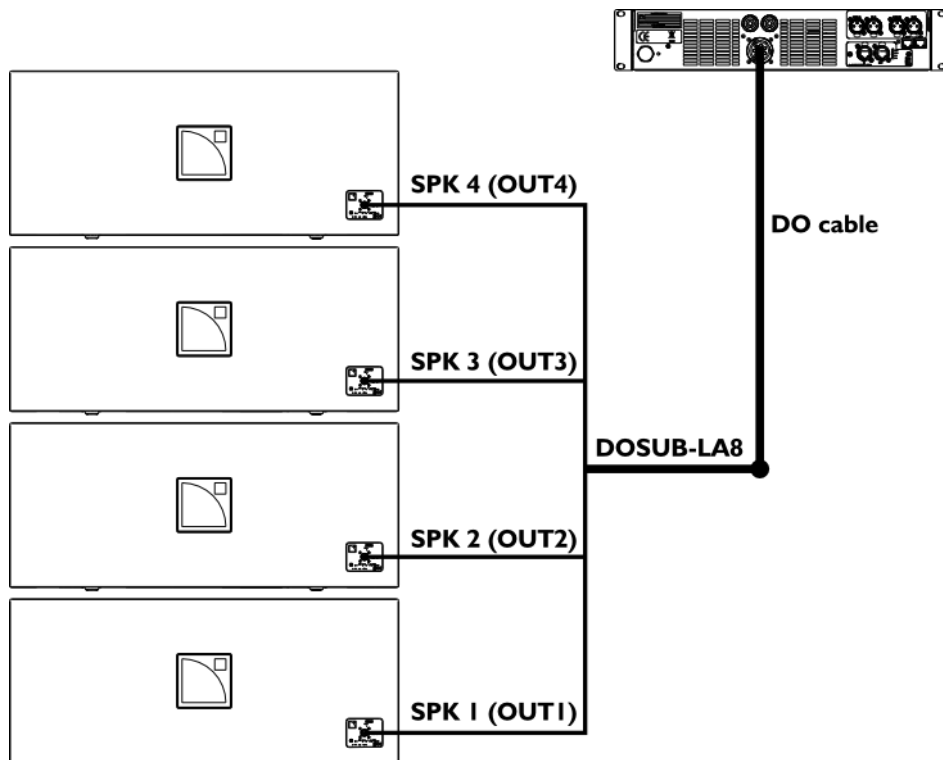

### Option B

- ▶ Connect one **SP** cable (SP.7, SP5, SP10 or SP25) to both LA8 SpeakON® connectors.
- ▶ Use an **SP-YI** cable and a **CC4FP** adapter to split the audio signals into two channels, each one feeding one subwoofer.

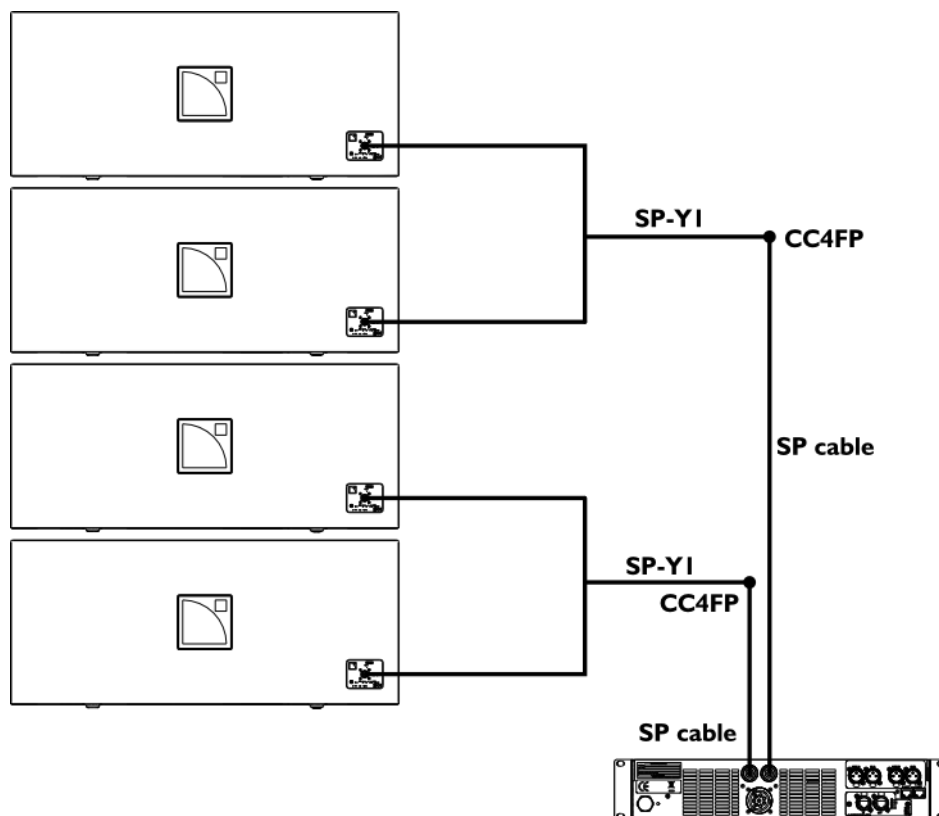

# KARA® / KARAI SYSTEM

## USER MANUAL

VERSION 3.1

### 4.5 Connecting KARA to LA4X



#### Maximum of 4 enclosures per LA4X

2 KARA enclosures can be connected in parallel to each pair of output channels on the LA4X (1/2 and 3/4).



#### Impedance load

1 enclosure 8  $\Omega$

2 enclosures 4  $\Omega$

- ▶ Connect one **SP** cable (SP.7, SP5, SP10 or SP25) to the OUT1/OUT2 and OUT3/OUT4 connectors of the LA4X.
- ▶ Use **SP** cables to connect additional similar enclosures in parallel with the first ones.

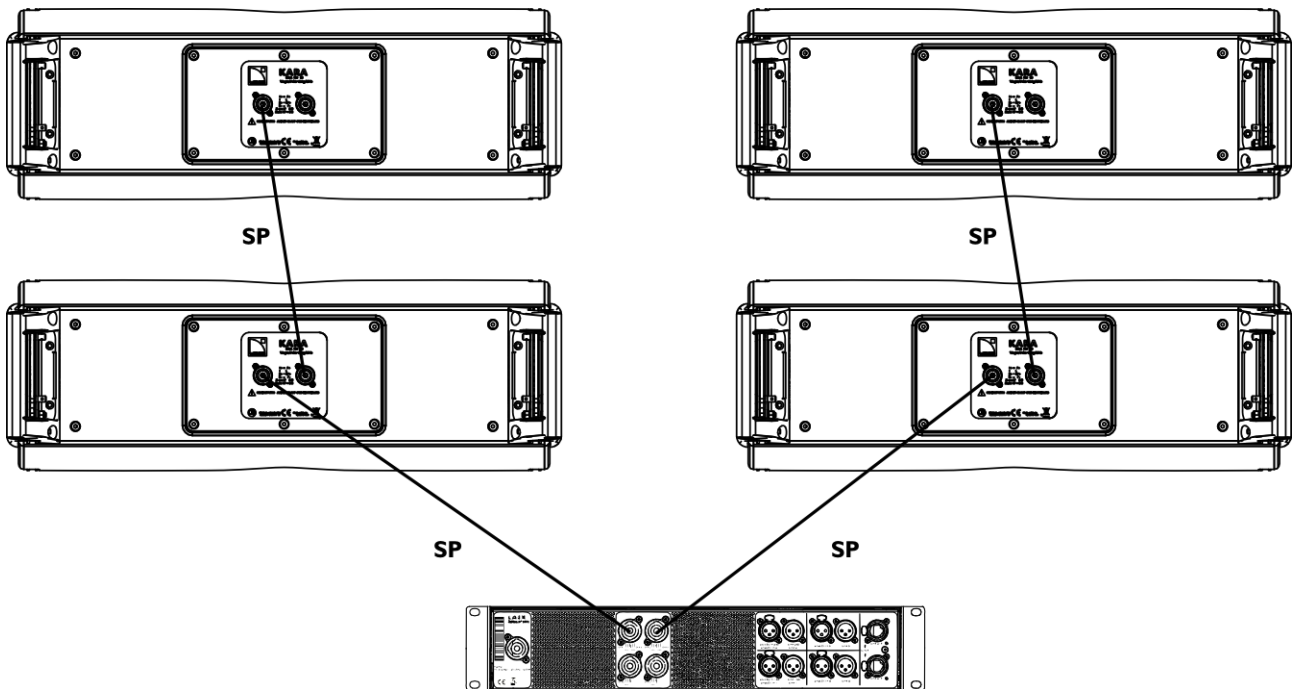

#### 4.6 Connecting SB18 to LA4X



##### Maximum of 4 enclosures per LA4X

1 SB18 can be connected to each output channel on the LA4X.



##### Impedance load

1 enclosure  $8 \Omega$



##### CARDIOID mode with SB28

Connect the reversed.

##### Option A

- Use an **SP** cable (SP5, SP10 or SP25) to connect one enclosure to each output channel of the LA4X.

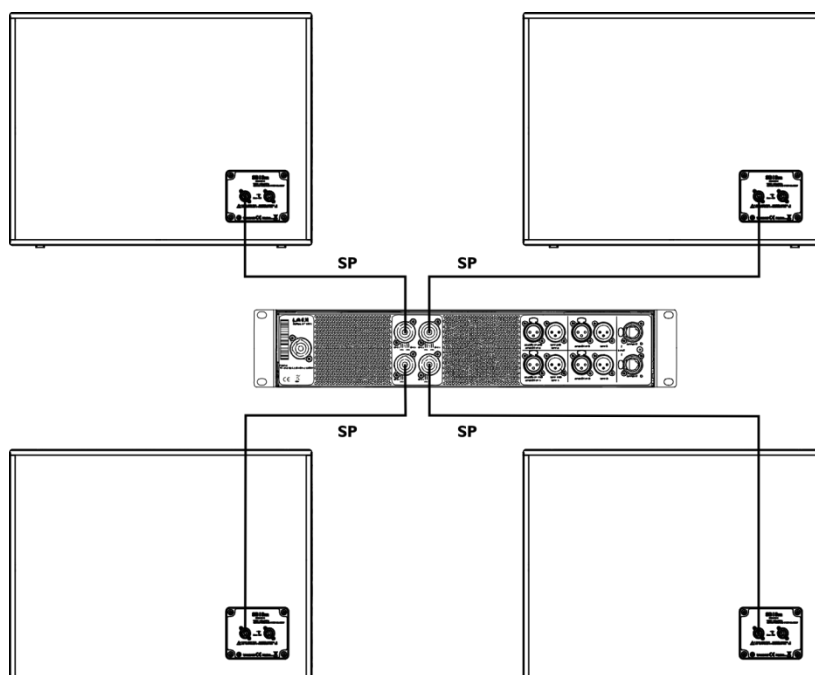

##### Option B

- Connect one **SP** cable (SP.7, SP5, SP10 or SP25) to the OUT1/OUT2 and OUT3/OUT4 connectors of the LA4X.
- Use an **SP-YI** cable and a **CC4FP** adapter to split the audio signals into two channels, each one feeding one subwoofer.

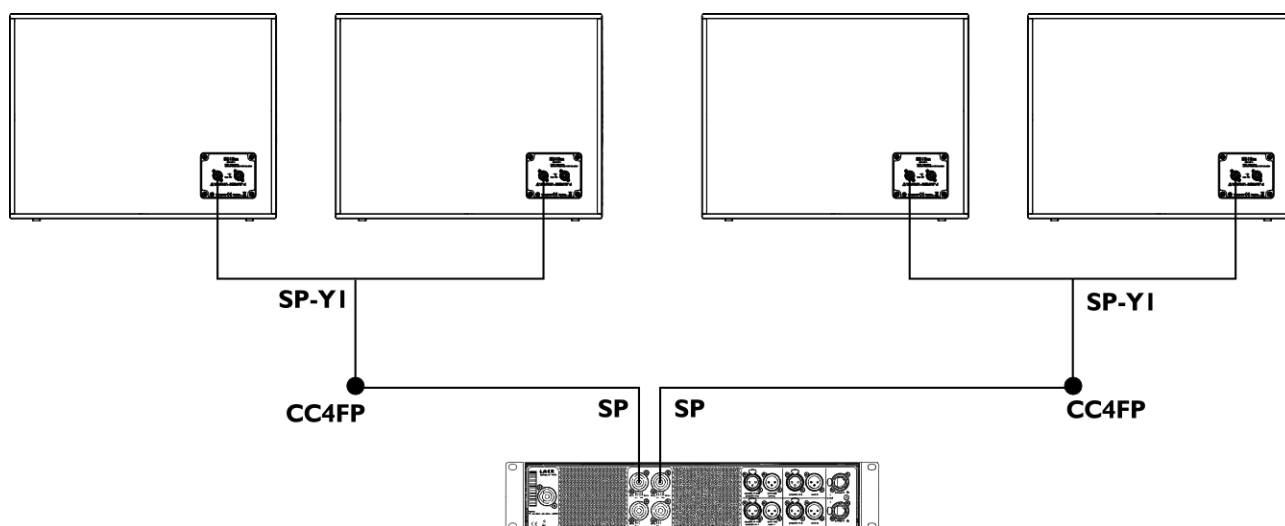

### APPENDIX A PRESET DESCRIPTION

#### [KARA]

The [KARA] preset allows for a reference frequency response in long throw applications.

Loudspeaker elements		Amplifier outputs	Channels	Default parameters				
				Routing	Gain	Delay	Polarity	Mute
KARA	LF	OUT 1	LF	IN A	0 dB	0 ms	+	ON
	HF	OUT 2	HF					ON
KARA	LF	OUT 3	LF	IN B	0 dB	0 ms	+	ON
	HF	OUT 4	HF					ON

#### [KARA\_FI]

The [KARA] preset allows for a flat frequency response in short throw applications.

Loudspeaker elements		Amplifier outputs	Channels	Default parameters				
				Routing	Gain	Delay	Polarity	Mute
KARA	LF	OUT 1	LF	IN A	0 dB	0 ms	+	ON
	HF	OUT 2	HF					ON
KARA	LF	OUT 3	LF	IN B	0 dB	0 ms	+	ON
	HF	OUT 4	HF					ON

#### [SB18\_60]

The [SB\*\*\_60] preset provides the SB\*\* enclosures with an upper frequency limit at 60 Hz, for an optimal frequency coupling with a separated KARA line source.

Loudspeaker elements	Amplifier outputs	Channels	Default parameters				
			Routing	Gain	Delay	Polarity	Mute
SB**	OUT 1	SB	IN A	0 dB	0 ms	+	ON
SB**	OUT 2	SB	IN A	0 dB	0 ms	+	ON
SB**	OUT 3	SB	IN B	0 dB	0 ms	+	ON
SB**	OUT 4	SB	IN B	0 dB	0 ms	+	ON

#### [SB\*\*\_60\_C]

The [SB\*\*\_60] preset provides the SB\*\* enclosures with an upper frequency limit at 60 Hz, for an optimal frequency coupling with a separated KARA line source. It features optimized delay settings for SB\*\* arrays in cardioid configuration.

Loudspeaker elements	Amplifier outputs	Channels	Default parameters				
			Routing	Gain	Delay	Polarity	Mute
Reversed SB**	OUT 1	SR*	IN A	0 dB	0 ms	+	ON
SB**	OUT 2	SB					ON
SB**	OUT 3	SB					ON
SB**	OUT 4	SB					ON

\* reversed subwoofer

### [SB\*\*\_100]

The [SB\*\*\_100] preset provides the SB\*\* enclosures with an upper frequency limit at 100 Hz, for an optimal frequency coupling with a coupled KARA line source.

Loudspeaker elements	Amplifier outputs	Channels	Default parameters				
			Routing	Gain	Delay	Polarity	Mute
SB**	OUT 1	SB	IN A	0 dB	0 ms	+	ON
SB**	OUT 2	SB	IN A	0 dB	0 ms	+	ON
SB**	OUT 3	SB	IN B	0 dB	0 ms	+	ON
SB**	OUT 4	SB	IN B	0 dB	0 ms	+	ON

### [SB\*\*\_100\_C]

The [SB\*\*\_100] preset provides the SB\*\* enclosures with an upper frequency limit at 100 Hz, for an optimal frequency coupling with a coupled KARA line source. It features optimized delay settings for SB\*\* arrays in cardioid configuration.

Loudspeaker elements	Amplifier outputs	Channels	Default parameters				
			Routing	Gain	Delay	Polarity	Mute
Reversed SB**	OUT 1	SR*	IN A	0 dB	0 ms	+	ON
SB**	OUT 2	SB					ON
SB**	OUT 3	SB					ON
SB**	OUT 4	SB					ON

\* reversed subwoofer

## APPENDIX B RECOMMENDATION FOR SPEAKER CABLES



### Cable quality and resistance

Only use high-quality fully insulated speaker cables made of stranded copper wire.

Use cables of gauge offering low resistance per unit length and keep the cables as short as possible.

The following table provides the recommended maximum length depending on the cable cross-section and on the impedance load connected to the amplifier.

Cable cross-section			Recommended maximum length					
			8 Ω load		4 Ω load		2.7 Ω load	
mm <sup>2</sup>	SWG	AWG	m	ft	m	ft	m	ft
2.5	15	13	30	100	15	50	10	33
4	13	11	50	160	25	80	17	53
6	11	9	74	240	37	120	25	80
10	9	7	120	390	60	195	40	130

# KARA® / KARAI SYSTEM

## USER MANUAL

VERSION 3.1

### APPENDIX C SPECIFICATIONS

#### KARA

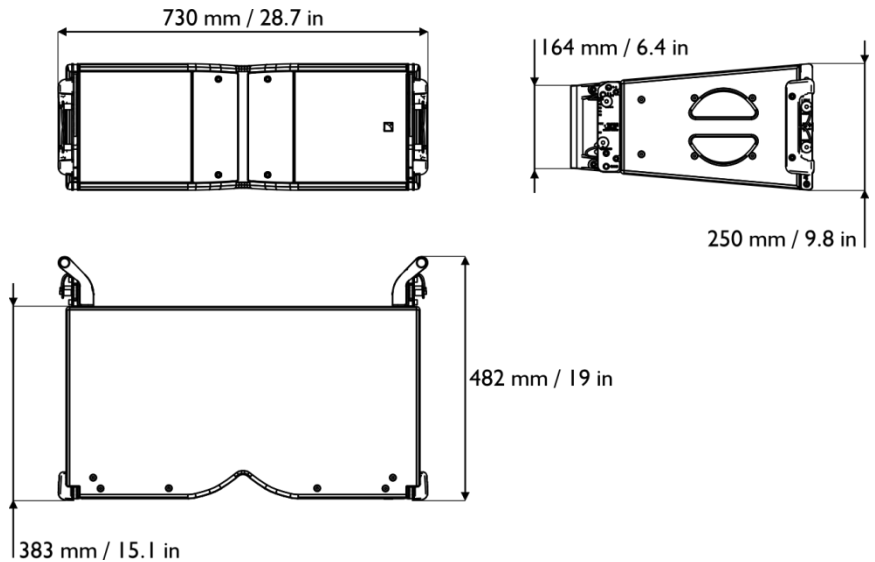
<b>Description</b>	2-way active enclosure, bi-amplified by LA4X or LA8	
<b>Usable bandwidth (-10 dB)</b>	55 Hz - 20 kHz ([KARA] preset)	
<b>Maximum SPL<sup>1</sup></b>	139 dB ([KARA] preset)	
<b>Coverage angle (-6 dB)</b>	Horizontal : 110° symmetric Vertical : dependent upon number of elements and array curvature	
<b>Transducers</b>	LF: 2 × 8", neodymium, weather-resistant, bass-reflex	
	HF: 1 × 3", neodymium, diaphragm compression driver, DOOSC® waveguide	
<b>Nominal impedance</b>	8 Ω	
<b>RMS power handling</b>	LF: 450 W HF: 80 W	
<b>Connectors</b>	IN : 1 × 4-point SpeakON®	LINK : 1 × 4-point SpeakON®
<b>Rigging components</b>	Captive rigging system. Inter-enclosure angles: 0°, 1°, 2°, 3°, 4°, 5°, 7.5° or 10°. Handles integrated into the cabinet.	
<b>Dimensions</b>		
<b>Physical data</b>	<b>Weight (net):</b>	26 kg / 57 lb
	<b>Cabinet:</b>	first grade Baltic birch plywood
	<b>Finish:</b>	Dark grey Brown (Pantone 426C) Pure white (RAL 9010®)
	<b>Front:</b>	Steel grill with anti-corrosion coating Airnet® acoustically neutral fabric
	<b>Protection Rating:</b>	IP45
	<b>Rigging components:</b>	High grade steel with anti-corrosion coating

<sup>1</sup> Peak level at 1 m under free field conditions using 10 dB crest factor pink noise with specified preset.

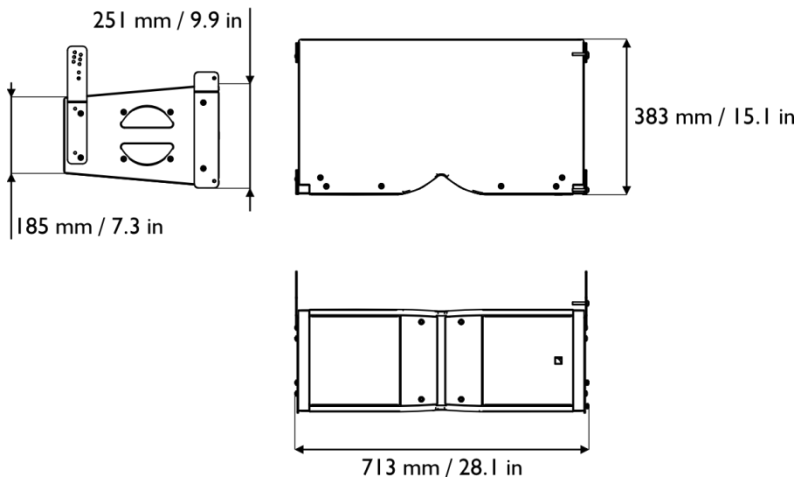

## KARAI

<b>Description</b>	2-way active enclosure, bi-amplified by LA4X or LA8, for permanent installation.	
<b>Usable bandwidth (-10 dB)</b>	55 Hz - 20 kHz ([KARA] preset)	
<b>Maximum SPL<sup>1</sup></b>	139 dB ([KARA] preset)	
<b>Coverage angle (-6 dB)</b>	Horizontal : 110° symmetric Vertical : dependent upon number of elements and array curvature	
<b>Transducers</b>	LF: 2 × 8", neodymium, weather-resistant, bass-reflex	
	HF: 1 × 3", neodymium, diaphragm compression driver, DOSC® waveguide	
<b>Nominal impedance</b>	8 Ω	
<b>RMS power handling</b>	LF: 450 W HF: 80 W	
<b>Connectors</b>	IN : 1 × 4-point SpeakON®	LINK : 1 × 4-point SpeakON®
<b>Rigging components</b>	Captive rigging system. Inter-enclosure angles: 0°, 1°, 2°, 3°, 4°, 5°, 7.5° or 10°. Handles integrated into the cabinet.	
<b>Dimensions</b>		
<b>Physical data</b>	<b>Weight (net):</b>	23.5 kg / 51.7 lbs.
	<b>Cabinet:</b>	first grade Baltic birch plywood
	<b>Finish:</b>	Dark grey Brown (Pantone 426C) Pure white (RAL 9010®) Custom RAL code on special order
	<b>Front:</b>	Steel grill with anti-corrosion coating Airnet® acoustically neutral fabric
	<b>Protection Rating:</b>	IP45
	<b>Rigging components:</b>	High grade steel with anti-corrosion coating

<sup>1</sup> Peak level at 1 m under free field conditions using 10 dB crest factor pink noise with specified preset.

# KARA® / KARAI SYSTEM

## USER MANUAL

VERSION 3.1

### SB18

<b>Description</b>	Subwoofer enclosure, amplified by LA4X or LA8	
<b>Low frequency limit (-10 dB)</b>	32 Hz ([SB18_100] preset)	
<b>Maximum SPL<sup>1</sup></b>	136 dB ([SB18_100] preset)	
<b>RMS power handling</b>	700 W	
<b>Transducers</b>	1 × 18" weather-resistant, direct radiation, dual bass-reflex	
<b>Nominal impedance</b>	8 Ω	
<b>Connectors</b>	IN: 1 × 4-point SpeakON®	LINK: 1 × 4-point SpeakON®
<b>Rigging components</b>	Integrated pole-mount socket Integrated rigging system Handles integrated into the cabinet	

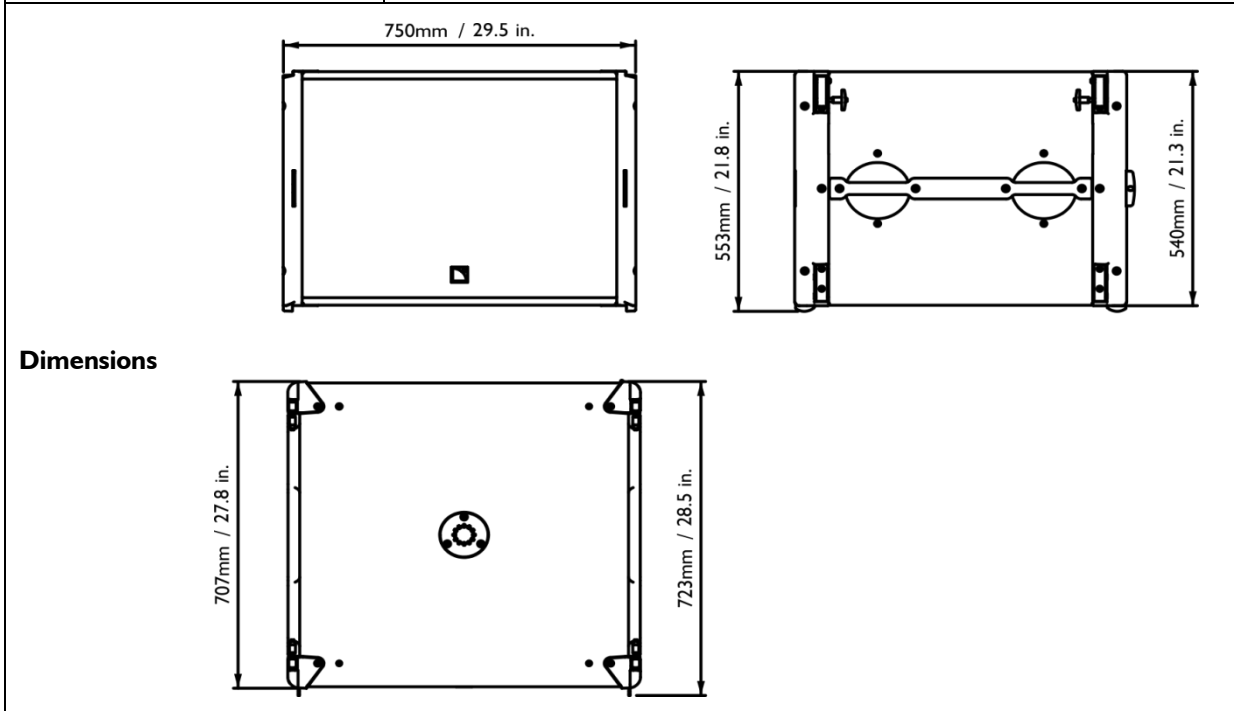

<b>Physical data</b>	<b>Weight (net):</b>	52 kg / 115 lb
	<b>Cabinet:</b>	Baltic birch plywood
	<b>Finish:</b>	Dark Grey brown (Pantone 426C) Pure white (RAL 9010®)
	<b>Front:</b>	Steel grill with anti-corrosion coating Airnet® acoustically neutral fabric
	<b>Protection rating</b>	IP45
	<b>Rigging components:</b>	Steel with anti-corrosion coating

<sup>1</sup> Peak level at 1 m under half-space conditions using 10 dB crest factor pink noise with specified preset.

**SB18i**

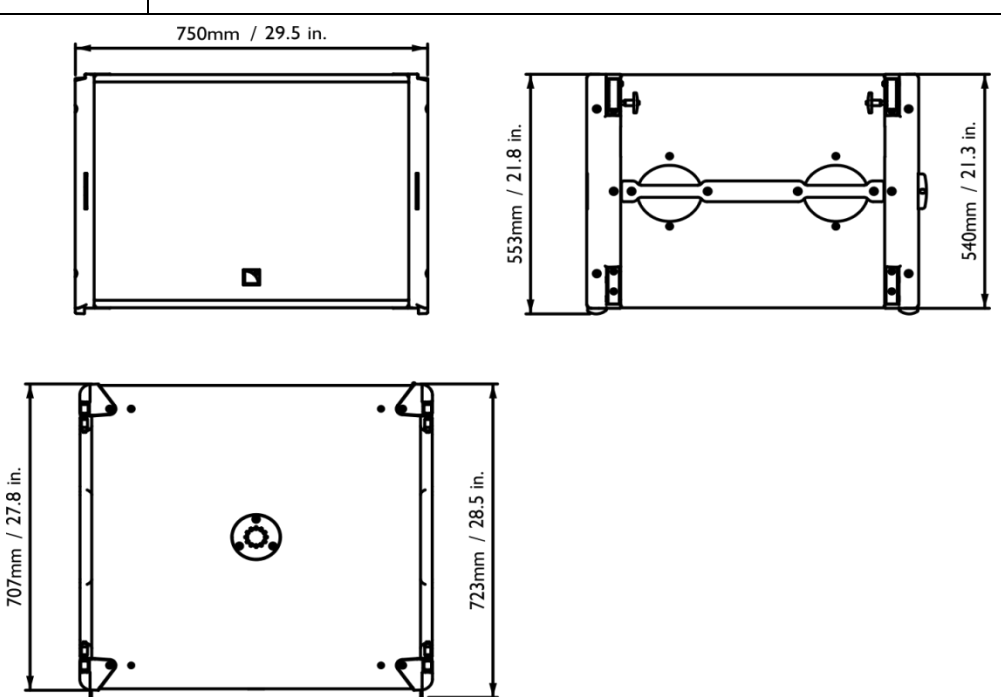
<b>Description</b>	Subwoofer enclosure, amplified by LA4X or LA8	
<b>Low frequency limit (-10 dB)</b>	32 Hz ([SB18_100] preset)	
<b>Maximum SPL<sup>1</sup></b>	136 dB ([SB18_100] preset)	
<b>RMS power handling</b>	700 W	
<b>Transducers</b>	1 × 18" weather-resistant, direct radiation, dual bass-reflex	
<b>Nominal impedance</b>	8 Ω	
<b>Connectors</b>	IN: 1 × 4-point SpeakON®	LINK: 1 × 4-point SpeakON®
<b>Rigging components</b>	Integrated pole-mount socket Integrated rigging system Handles integrated into the cabinet	
<b>Dimensions</b>		
<b>Physical data</b>	<b>Weight (net):</b>	52 kg / 115 lb
	<b>Cabinet:</b>	Baltic birch plywood
	<b>Finish:</b>	Dark Grey brown (Pantone 426C) Pure white (RAL 9010®)
	<b>Front:</b>	Steel grill with anti-corrosion coating Airnet® acoustically neutral fabric
	<b>Protection rating</b>	IP45
	<b>Rigging components:</b>	Steel with anti-corrosion coating

<sup>1</sup> Peak level at 1 m under half-space conditions using 10 dB crest factor pink noise with specified preset.

# KARA® / KARAI SYSTEM

## USER MANUAL

VERSION 3.1

### SB28

<b>Description</b>	Subwoofer enclosure, amplified by the LA8
<b>Low frequency limit (-10 dB)</b>	25 Hz ([SB28_100] preset)
<b>Maximum SPL<sup>1</sup></b>	140 dB ([SB28_100] preset)
<b>RMS power handling</b>	1255 W
<b>Transducers</b>	2 × 18" neodymium, weather-resistant, direct radiation, bass-reflex
<b>Nominal impedance</b>	4 Ω
<b>Connectors</b>	IN: 1 × 4-point SpeakON®
<b>Rigging components</b>	Integrated rigging system Handles integrated in the cabinet

#### Dimensions

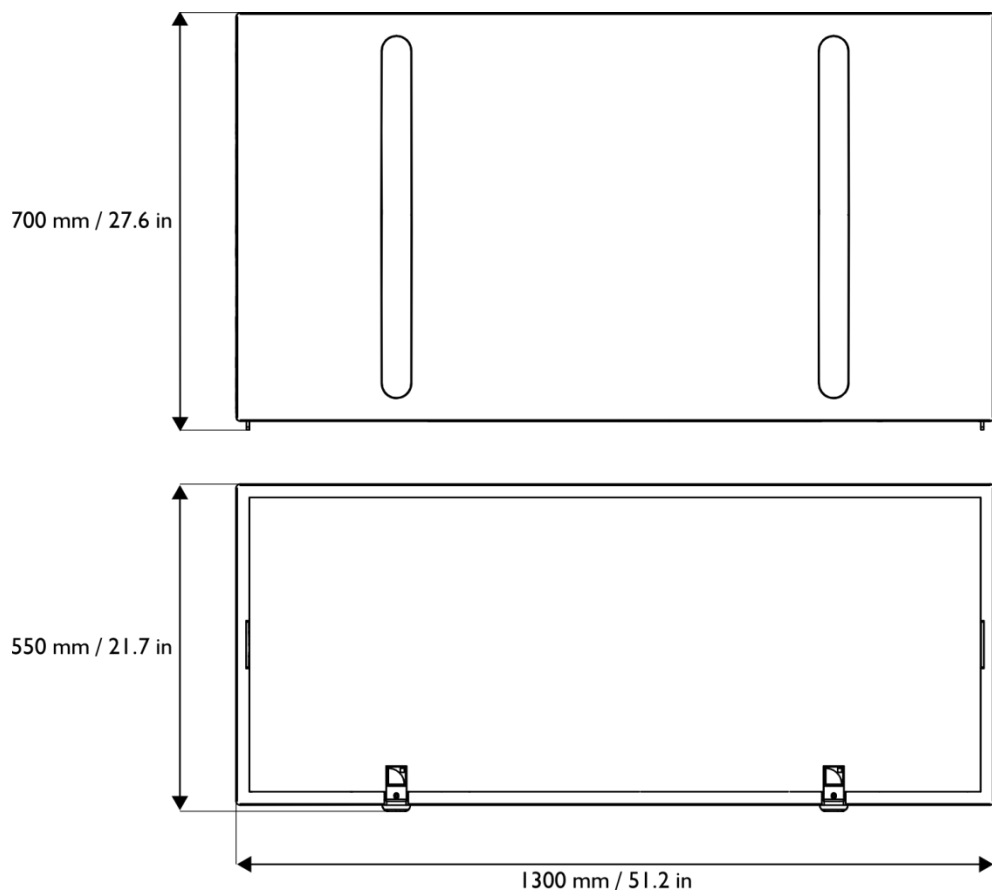

<b>Physical data</b>	<b>Weight (net):</b>	93 kg / 205 lb
	<b>Cabinet:</b>	Baltic birch plywood
	<b>Finish:</b>	Dark Grey brown (Pantone 426C) Pure white (RAL 9010®)
	<b>Front:</b>	Steel grill with anti-corrosion coating Airnet® acoustically neutral fabric
	<b>Rigging components:</b>	Aluminium

<sup>1</sup> Peak level at 1 m under half-space conditions using 10 dB crest factor pink noise with specified preset.



**Document reference: KARA\_UM\_EN\_3.0**

**Distribution date: March 9, 2015**

**© 2015 L-ACOUSTICS®. All rights reserved.**

**No part of this publication may be reproduced or transmitted in any form  
or by any means without the express written consent of the publisher.**