ROBE

ROBIN[®] 100

LEDBeam

ROBIN[®] 100

LEDBeam Wireless DMX

CRMX[™]

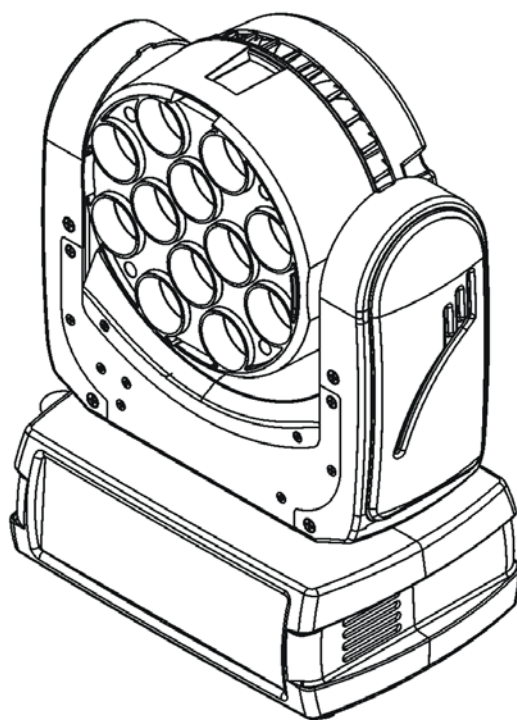

ROBE
Innovative
Technology

USER MANUAL

Version 1.7

ROBE[®] lighting s.r.o. • Czech Republic • www.robe.cz

Robin 100 LEDBeam

Robin 100 LEDBeam Wireless DMX

Table of contents

1. Safety instructions	3
2. Fixture exterior view	5
3. Installation	6
3.1 Connection to the mains	6
3.2 Installing the top hat	7
3.3 Installing the diffusion filter	8
3.4 Rigging the fixture	9
3.5 DMX-512 connection.....	11
3.6. Wireless DMX operation	12
4. Control menu map	13
5. Robin 100 LEDBeam - DMX chart	15
5.1 Virtual colour wheel - colour mixing chart	19
5.2 LED zone order	23
6. Control menu	24
6.1 Addressing (DMXA)	24
6.2 Fixture information (Info)	24
6.3 Personality (Pers).....	25
6.4 Manual Control (Manual).....	26
6.5 Test program (Test Prg).....	26
6.6 Stand-alone (St Alone)	26
6.7 Reset.....	27
6.8 Special functions (Special).....	27
7. RDM	28
8. Error and information messages	29
9. Technical Specifications	29
10. ChangeLog	32
11. Maintenance and cleaning	32
11.1 Replacing fuse	33
12. Photometric diagrams	34

**FOR YOUR OWN SAFETY, PLEASE READ THIS USER MANUAL CAREFULLY
BEFORE POWERING OR INSTALLING YOUR ROBIN 100 LEDBeam !**

Save it for future reference.

This device has left our premises in absolutely perfect condition. In order to maintain this condition and to ensure a safe operation, it is absolutely necessary for the user to follow the safety instructions and warning notes written in this manual.

The manufacturer will not accept liability for any resulting damages caused by the non-observance of this manual or any unauthorized modification to the device.

Please consider that damages caused by manual modifications to the device are not subject to warranty.

The Robin 100 LEDBeam was designed for indoor use and it is intended for professional application only. It is not for household use.

1. Safety instructions

DANGEROUS VOLTAGE CONSTITUTING A RISK OF ELECTRIC SHOCK IS PRESENT WITHIN THIS UNIT!

Make sure that the available voltage is not higher than stated on the rear panel of the fixture. This fixture should be operated only from the type of power source indicated on the marking label. If you are not sure of the type of power supplied, consult your authorized distributor or local power company.

Always disconnect the fixture from AC power before cleaning, removing or installing the fuses, or any part.

The power plug has to be accessible after installing the fixture. Do not overload wall outlets and extension cords as this can result in fire or electric shock.

Do not allow anything to rest on the power cord. Do not locate this fixture where the cord may be damaged by persons walking on it.

Make sure that the power cord is never crimped or damaged by sharp edges. Check the fixture and the power cord from time to time.

Refer servicing to qualified service personnel.

This fixture falls under protection class I. Therefore this fixture has to be connected to a mains socket outlet with a protective earthing connection.

Do not connect this fixture to a dimmer pack.

LED light emission. Risk of eye injury. Do not look into the beam at a distance of less than 2 meters from the front surface of the product. Do not view the light output with optical instruments or any device that may concentrate the beam

If the fixture has been exposed to drastic temperature fluctuation (e.g. after transportation), do not switch it on immediately. The arising condensation water might damage your device. Leave the device switched off until it has reached room temperature.

Do not shake the fixture. Avoid brute force when installing or operating the fixture.

This fixture was designed for indoor use only, do not expose this unit to rain or use near water.

When choosing the installation spot, please make sure that the fixture is not exposed to extreme heat, moisture

or dust.

Air vents and slots in the fixture's head and base are provided for ventilation, to ensure reliable operation of the device and to protect it from overheating.

Do not block the LEDs array with any object when the fixture is under operation.

The openings should never be covered with cloth or other materials, and never must be blocked.

This fixture should not be placed in a built-in installation unless proper ventilation is provided.

Only operate the fixture after having checked that the housing is firmly closed and all screws are tightly fastened.

Always use a secondary safety cable when mounting this fixture.

Make sure that the area below the installation place is blocked when rigging, derigging or servicing the fixture.

Do not block the front objective LEDs with any object when the fixture is under operation.

The fixture becomes very hot during operation. Allow the fixture to cool approximately 20 minutes prior to manipulate with it.

Operate the fixture only after having familiarized with its functions. Do not permit operation by persons not qualified for operating the fixture. Most damages are the result of unprofessional operation!

Please use the original packaging if the fixture is to be transported.

Please consider that unauthorized modifications on the fixture are forbidden due to safety reasons!

If this device will be operated in any way different to the one described in this manual, the product may suffer damages and the guarantee becomes void. Furthermore, any other operation may lead to dangers like short-circuit, burns, electric shock, crash etc.

2. Fixture exterior view

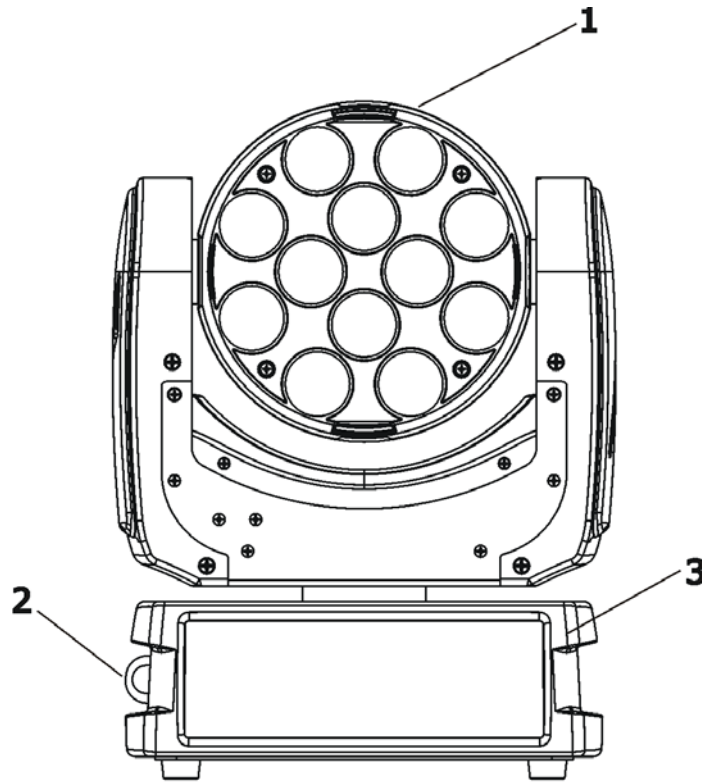

- 1 - Moving head
- 2 - Attachment point for safety cable
- 3 - Base

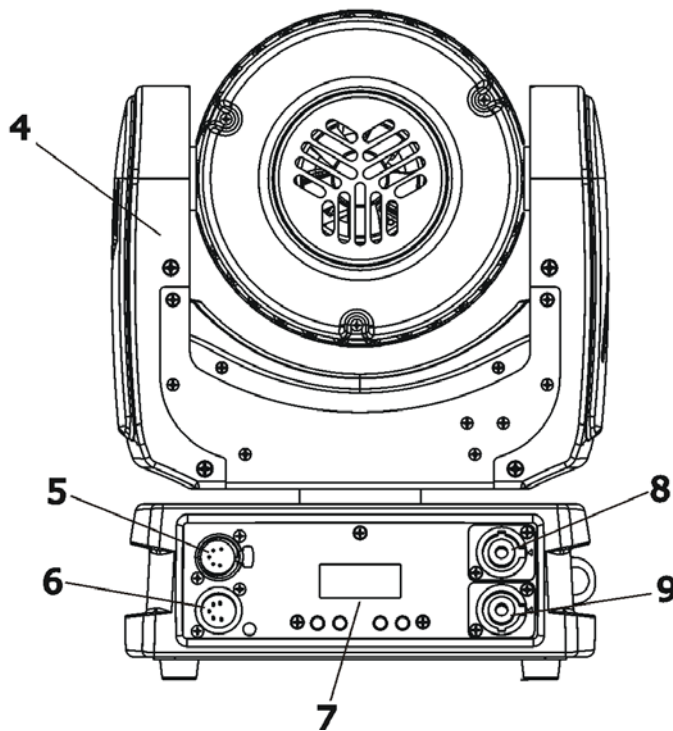

- 4 - Yoke
- 5 - DMX out
- 6 - DMX in
- 7 - Control board
- 8 - Mains in
- 9 - Mains out

3. Installation



Fixtures must be installed by a Qualified electrician in accordance with all national and local electrical and construction codes and regulation.

3.1 Connection to the mains

For protection from electric shock, the fixture must be earthed!

The Robin 100 LEDBeam is equipped with auto-switching power supply that automatically adjusts to any 50-60Hz AC power source from 100-240 Volts.

Install a suitable plug on the power cord, note that the cores in the power cord are coloured according to the following table. The earth has to be connected!

If you have any doubts about proper installation, consult a qualified electrician.

Core (EU)	Core (US)	Connection	Plug Terminal Marking
Brown	Black	Live	L
Light blue	White	Neutral	N
Yellow/Green	Green	Earth	

This device falls under class one and must be earthed (grounded)!

Design of the Robin 100 LEDBeam allows to connect several fixtures to AC mains power in one interconnected daisy chain using power input and throughput connectors. Needed daisy chain cords are stated in the chapter "Technical specifications "

The max. number of connected fixtures depends on the AC mains power voltage:

12 fixtures at power supply= 230V

10 fixtures at power supply= 208V

6 fixtures at power supply= 120V

Do not overload the supply line and the connecting leads.

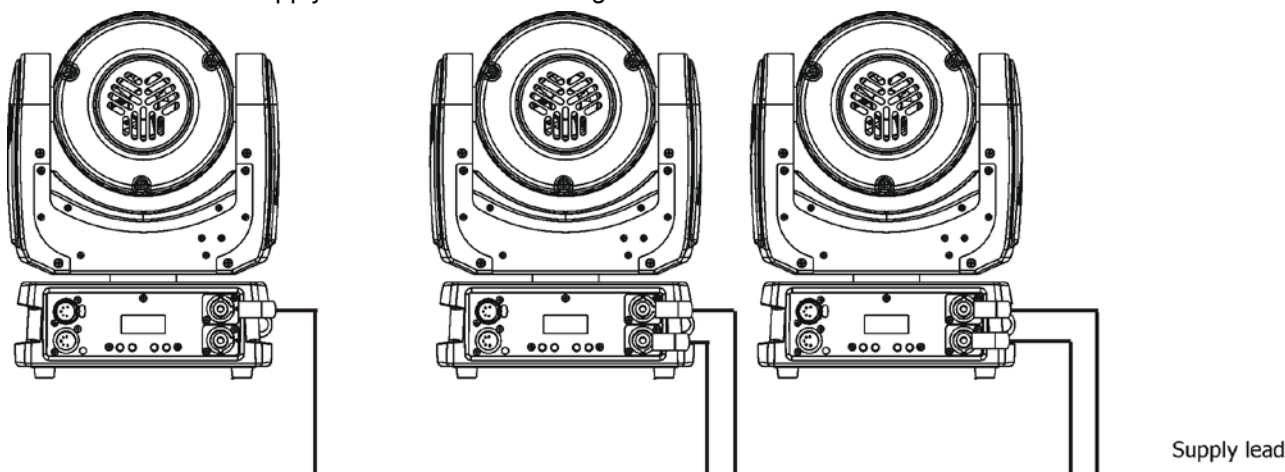

Wiring and connection work must be carried out by qualified staff!

3.2 Installing the top hat

Disconnect the fixture from mains before top hat installation

1. Go to the fixture menu and limit tilt movement (Pers --> Tilt Red--> On).

2. Put the top hat (1) on the head of the fixture (3) in such a way that both clips (2) of the top hat snap into cavities (4) in the head. Check that both clips are firmly engaged in the head cavities.

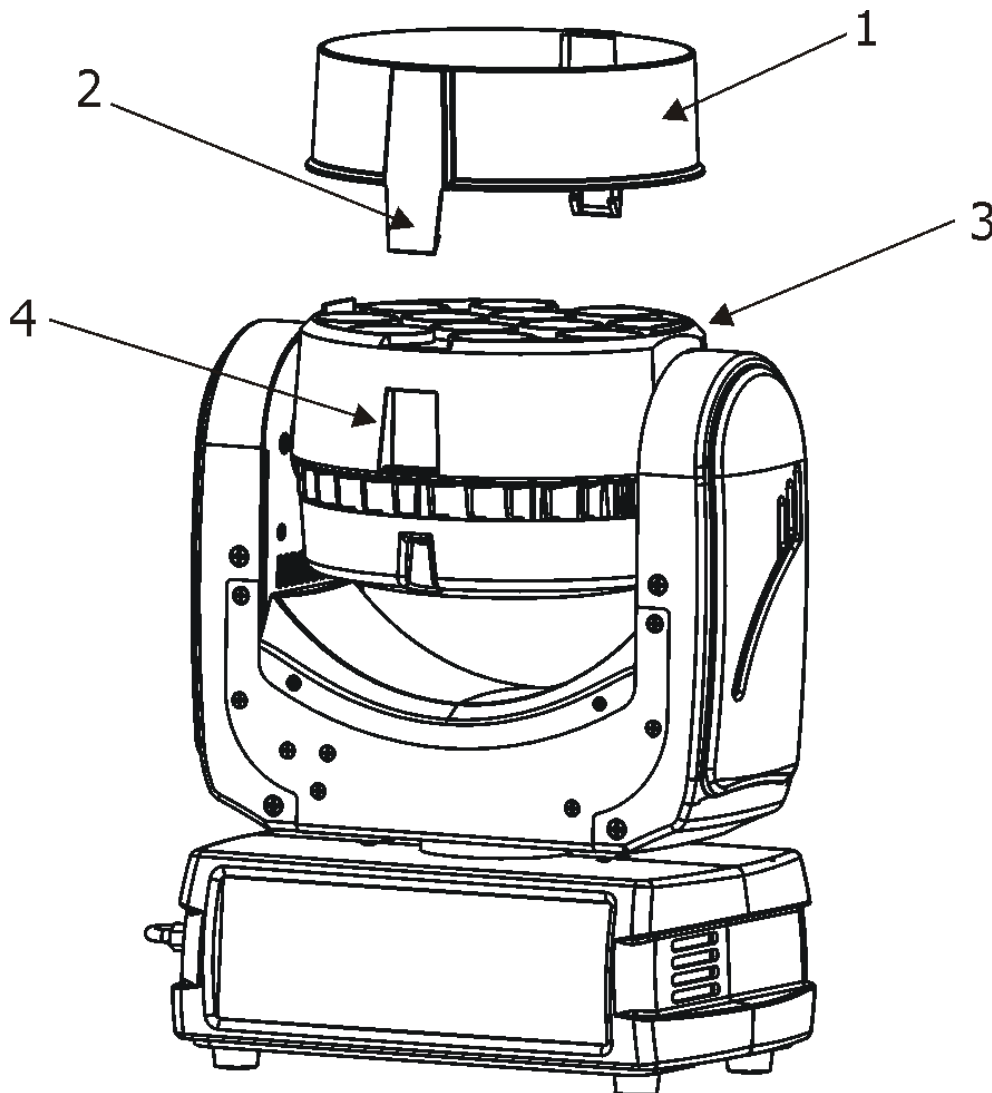

3.3 Installing the diffusion filter

Disconnect the fixture from mains before diffusion filter installation

1. Insert two screws (1) into holder with diffusion filter (2) and secure them with securing washers (3).

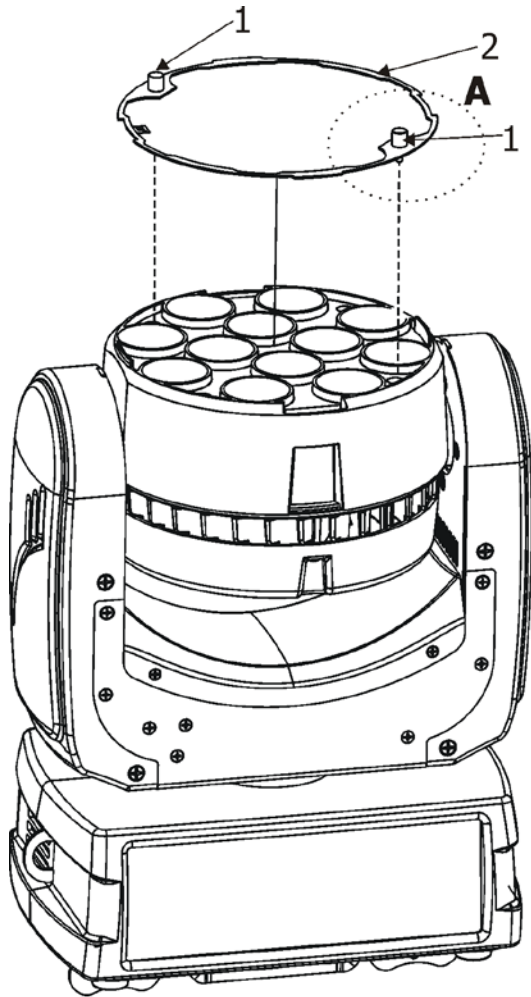

Detail A

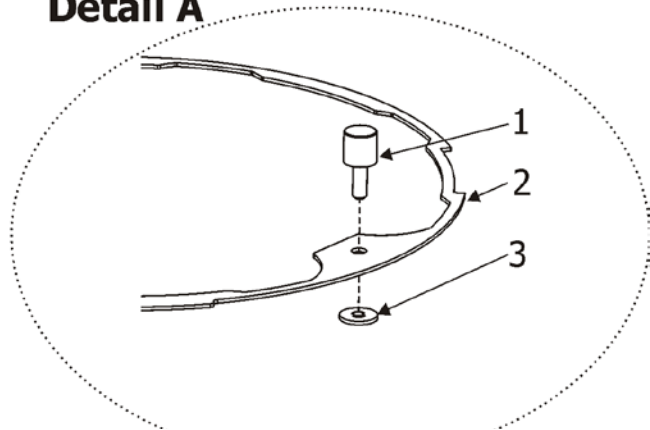

2. Screw the holder (3) to the head via two screws (1).

3.4 Rigging the fixture

The installation of the fixture has to be built and constructed in a way that it can hold 10 times the weight for 1 hour without any harming deformation.

The installation must always be secured with a secondary safety attachment, e.g. an appropriate catch net. This secondary safety attachment must be constructed in a way that no part of the installation can fall down if the main attachment fails.

When rigging, derigging or servicing the fixture staying in the area below the installation place, on bridges, under high working places and other endangered areas is forbidden.

The operator has to make sure that safety-relating and machine-technical installations are approved by an expert before taking into operation for the first time and after changes before taking into operation another time.

The operator has to make sure that safety-relating and machine-technical installations are approved by an expert after every four year in the course of an acceptance test.

The operator has to make sure that safety-relating and machine-technical installations are approved by a skilled person once a year.

The fixture should be installed outside areas where persons may walk by or be seated.

IMPORTANT! OVERHEAD RIGGING REQUIRES EXTENSIVE EXPERIENCE, including (but not limited to) calculating working load limits, installation material being used, and periodic safety inspection of all installation material and the projector. If you lack these qualifications, do not attempt the installation yourself, but instead use a professional structural rigger. Improper installation can result in bodily injury or damage to property. The fixture has to be installed out of the reach of people.

If the fixture shall be lowered from the ceiling or high joists, professional trussing systems have to be used. The fixture must never be fixed swinging freely in the room.

Caution: Fixture may cause severe injuries when crashing down! If you have doubts concerning the safety of a possible installation, do not install the moving head!

Before rigging make sure that the installation area can hold a minimum point load of 10 times the fixture's weight.

When installing the device, make sure there is no highly inflammable material (decoration articles, etc.) in a distance of min. 0.4 m.

CAUTION!
Use an appropriate clamp to rig the fixture on the truss.
Follow the instructions mentioned at the bottom of the base.
Make sure that the device is fixed properly! Ensure that the structure (truss) to which you are attaching the fixtures is secure.

The fixture can be placed directly on the stage floor or rigged on a truss without altering its operation characteristics .

For securing a fixture to the truss install a safety wire that can hold at least 10 times the weight of the fixture. Use only safety wire with screw-on carabine. **Fasten the safety cable in the attachment point and around the truss as shown on the picture below.**

Rigging via omega holder:

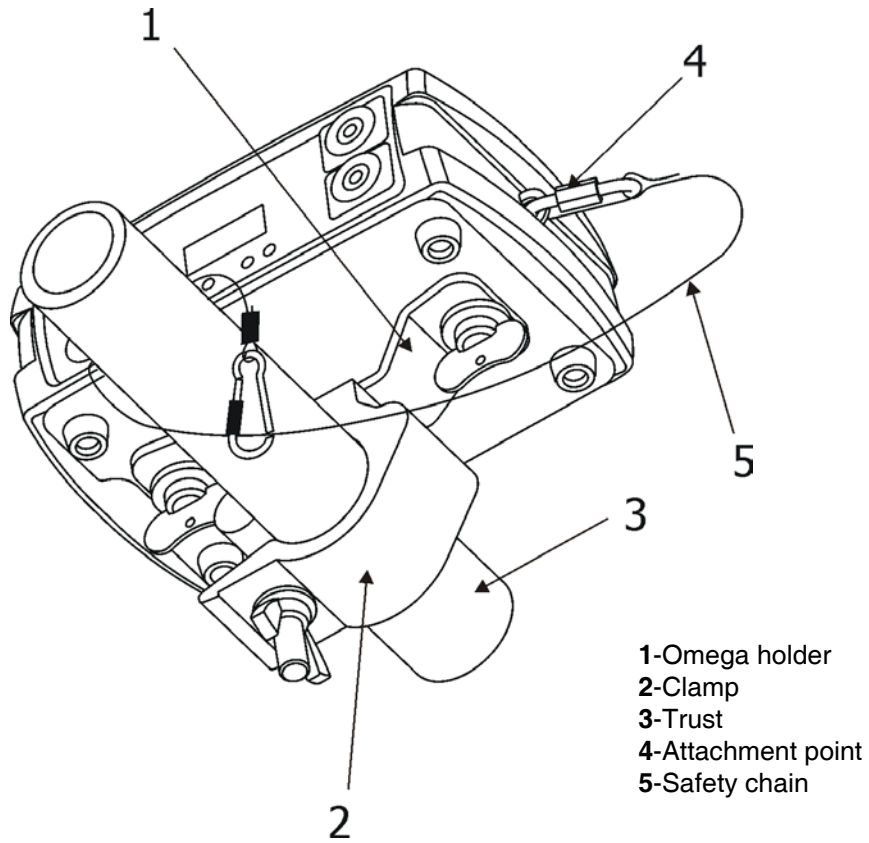

When installing fixtures side-by-side, avoid illuminating one fixture with another!

3.5 DMX-512 connection

The fixture is equipped with 5-pin XLR sockets for DMX input and output. Only use a shielded twisted-pair cable designed for RS-485 and 5-pin XLR-plugs and connectors in order to connect the controller with the fixture or one fixture with another.

DMX output

XLR socket:



- 1 - Shield
- 2 - Signal (-)
- 3 - Signal (+)
- 4 - Used for wireless DMX
- 5 - Used for wireless DMX

DMX input

XLR plug:



- 1 - Shield
- 2 - Signal (-)
- 3 - Signal (+)
- 4 - Used for wireless DMX
- 5 - Used for wireless DMX

If you are using the standard DMX controllers, you can connect the DMX output of the controller directly with the DMX input of the first fixture in the DMX-chain. If you wish to connect DMX-controllers with other XLR-outputs, you need to use adapter-cables.

Building a serial DMX-chain:

Connect the DMX-output of the first fixture in the DMX-chain with the DMX-input of the next fixture. Always connect one output with the input of the next fixture until all fixtures are connected. Up to 32 fixtures can be interconnected.

Caution: At the last fixture, the DMX-cable has to be terminated with a terminator. Solder a 120 Ω resistor between Signal (-) and Signal (+) into a 5-pin XLR-plug and plug it in the DMX-output of the last fixture.

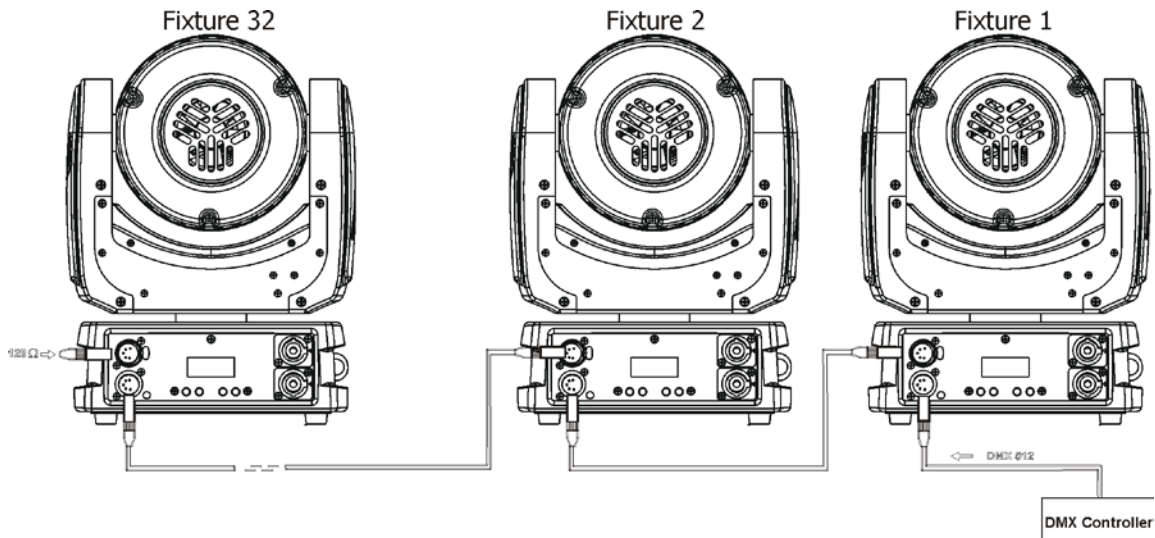

3.6. Wireless DMX operation

The external Robe Wireless CRMX-LB100 module allows receiving wireless DMX. This device is equipped with the Lumen Radio CRMX module and antenna for receiving DMX signal. CRMX module operates on the 2.4 GHz band.

Robe Wireless CRMX-LB100

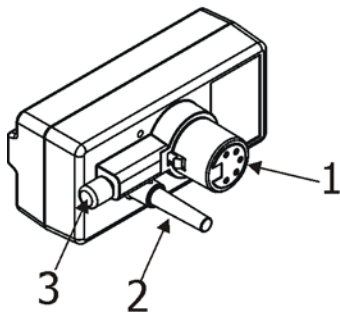

- 1 - 5-pin XLR (female)
- 2 - Locating pin
- 3 - Lock

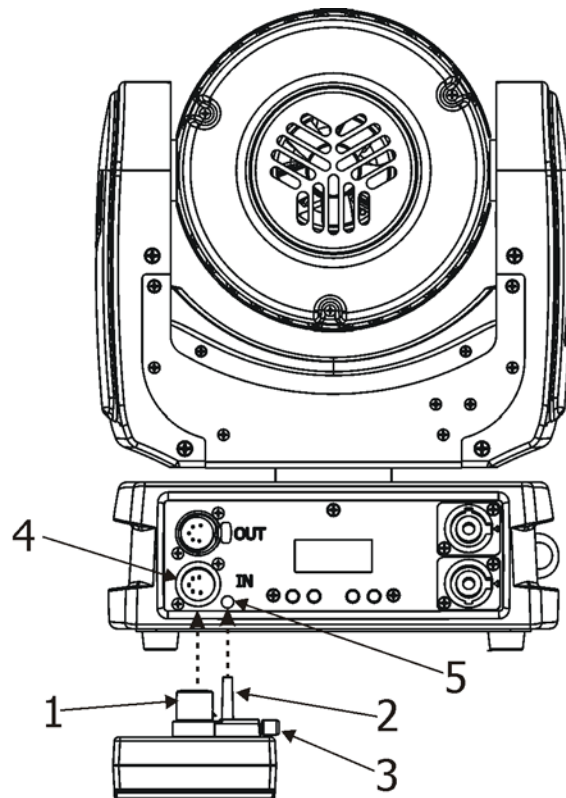

Push in the 5-pin XLR plug (1) into 5-pin XLR socket (4) and simultaneously locating pin (2) into hole (5) in the fixture. In this way the wireless DMX module is connected with the fixture.

NOTE: when you disconnect the DMX wireless module from fixture, press and hold lock (5) during getting the wireless module out.

To link the fixture with DMX transmitter.

The fixture can be only linked with the transmitter by running the link procedure at DMX transmitter.

After linking, the level of DMX signal (0-100 %) is displayed in the menu item "Stat" (Special -->Wireless -->Stat).

To unlink the fixture from DMX transmitter.

The fixture can be unlinked from receiver via the menu item "Unlink" (Special-->Wireless -->Unlink.).

Note: Wireless DMX operation is implemented in the processor IC-1 (Info -->Sw Ver). Version of this processor has to be following:

IC-1 = 2.2 and higher for RGBW version

IC-1 = 1.2 and higher for SmartWhite and Day Light version.

4. Control menu map

Default settings=**Bold print**

Level 1	Level 2	Level 3	Level 4	Level 5	Level 6	Level 7
DMXA	Set DMXA	001-255				
Info	POn Time	Total				
		Reset				
	DMX In	Pan	0-255			
		:				
		Dimm F	0-255			
	Temp	Current				
		Highest				
		High Res				
	Sw Ver	IC-1				
		IC-2				
		IC-3				
Pers						
	DMX Pres	Mode 1				
		:				
		Mode 6				
	Pan Rev	On, Off				
	Tilt Rev	On, Off				
	P/T Mode	Speed				
		Time				
	P/T Feed	On, Off				
	Tilt Red	On, Off				
	Display	Turn				
		On/Off T	On, Off			
		Contrast	0-100%			
		Backlight	0-100%			
	BLC DMC	On, Off				
	Act BLC	P/T Mov	On, Off			
	C Cal M	On, Off				
	C Mix M	RGBW, CMY				
	Mic Sens	0... 10 ...19				
	Fans	Auto, High				
	Temp Uni	°C, °F				
	I Ef Pos	Pan				
		:				
		Dimm F				
		Store				
	Defaults					
Test Prg	Static	Pan	0-255			
		Tilt	0-255			
		Run				
	Dynamic					
Manual	Pres Eff	Pan	Pos 1-Pos 3			
		:				
		Dimmer	Pos 1- Pos 5			
	Manual	Pan	0-255			
		:				
		Dimm F	0-255			

Level 1	Level 2	Level 3	Level 4	Level 5	Level 6	Level 7
Sta Alone	Music T	On, Off				
	Auti Run	Off				
		Test				
		Prog 1				
		Prog 2				
		Prog 3				
	Pr Play	Test Prg				
		Prog 1				
		Prog 2				
		Prog 3				
	Pr Edit	Prog 1	Step 1	Pan		
		Prog 2	:	:		
		Prog 3	Step 40	F.Tim	0-25.5	
				S.Tim	0-25.5	
				COPY		
				Prg End	1-40	
Reset						
Special	RDM Low					
	RDM Hight					
	Wireless	Stat				
		Unlink				
	Adjust	DMX Val	Pan	0-255		
			:			
			Dimm F	0-255		
		Calib	Pan C	0-255		
			Tilt C	0-255		
			Red C	0-255		
			Gren C	0-255		
			Blue C	0-255		
			Whit C	0-255		
			Store			
	Sw Upd	On, Off				

5.Robin 100 LEDBeam - DMX chart

Version 1.1

Mode/Channel						Value	Function	Type of control
1	2	3	4	5	6			
1	1	1	1	1	1	0-255	Pan (8 bit) Pan movement by 450°	proportional
2	2	2	2	2	2	0-255	Pan Fine (16 bit) Fine control of pan movement	proportional
3	3	3	3	3	3	0-255	Tilt (8bit) Tilt movement by 300°	proportional
4	4	4	4	4	4	0-255	Tilt fine (16 bit) Fine control of tilt movement	proportional
5	5	5	5	5	5	0	Pan/Tilt speed, Pan/Tilt time Max. speed (tracking mode)	step
						1 - 255	<i>P./T. speed-set Speed Mode in menu: P./T. Mode</i> Speed from max. to min. (vector mode)	proportional
						1 - 255	<i>P./T. time - set Time Mode in menu: Pan/Tilt Mode</i> Time from 0.1 s to 25.5 s.	proportional
6	6	6	6	6	6	0 - 9	Special functions Reserved <i>To activate following functions , stop in DMX value for at least 3sec. and shutter must be closed at least 3sec. (Shutter channel 33/17/13/8/7/35 must be at range of 0-31DMX). Corresponding menu items are temporarily overrided except DMX Input.</i>	
						10 - 29	Reserved	
						30 - 39	RGBW colour mixing mode	step
						40 - 49	CMY colour mixing mode	step
						50 - 59	Pan/Tilt speed mode	step
						60 - 69	Pan/Tilt time mode	step
						70 - 79	Blackout while pan/tilt moving	step
						80 - 89	Disabled blackout while pan/tilt moving	step
						90-109	Reserved	
						110-114	Colour calibration mode On	step
						115-119	Colour calibration mode Off	step
						120-124	Tilt movement reduction On	step
						125-129	Tilt movement reduction Off	step
						130-139	Reserved <i>To activate following reset functions, stop in DMX value for at least 3 sec.</i>	
140 - 149	Pan/Tilt reset	step						
150 - 199	Reserved							
200 - 209	Total reset	step						
210 - 255	Reserved							
-	7	7	-	-	-	0-255	Red/Cyan (8 bit) - all zones Red LEDs saturation control (0-100%)	proportional
-	8	-	-	-	-	0-255	Red/Cyan fine(16 bit) - all zones Fine red LEDs saturation control	proportional
-	9	8	-	-	-	0-255	Green/Magenta (8 bit) - all zones Green LEDs saturation control (0-100%)	proportional
-	10	-	-	-	-	0-255	Green/Magenta fine (16 bit) - all zones Fine green LEDs saturation control	proportional
-	11	9	-	-	-	0-255	Blue/Yellow (8 bit) - all zones Blue LEDs saturation control (0-100%)	proportional
-	12	-	-	-	-	0-255	Blue/Yellow fine (16 bit) - all zones Fine blue LEDs saturation control	proportional

Mode/Channel						Value	Function	Type of control
1	2	3	4	5	6			
-	13	10	-	-	-	0-255	White (8 bit) - all zones <i>If RGBW mode is selected:</i> White colour saturation control coarse (0-100%) <i>If CMY mode is selected:</i> No function	proportional
-	14	-	-	-	-	0-255	White fine (16 bit) - all zones Fine white LEDs saturation control (RGBW mode)	proportional
7	-	-	-	12	7	0-255	Red/Cyan (8 bit) - zone 1 Red LEDs saturation control (0-100%)	proportional
8	-	-	-	13	8	0-255	Red/Cyan fine (16 bit) - zone 1 Fine red LEDs saturation control	proportional
9	-	-	-	14	9	0-255	Green/Magenta (8 bit) - zone 1 Green LEDs saturation control (0-100%)	proportional
10	-	-	-	15	10	0-255	Green/Magenta fine (16 bit) - zone 1 Fine green LEDs saturation control	proportional
11	-	-	-	16	11	0-255	Blue/Yellow (8 bit) zone 1 Blue LEDs saturation control (0-100%)	proportional
12	-	-	-	17	12	0-255	Blue/Yellow (16 bit) zone 1 Fine blue LEDs saturation control	proportional
13	-	-	-	18	13	0-255	White (8 bit) - zone 1 <i>If RGBW mode is selected:</i> White colour saturation control coarse (0-100%) <i>If CMY mode is selected:</i> No function	proportional
14	-	-	-	19	14	0-255	White (16 bit) - zone 1 Fine white LEDs saturation control (RGBW mode)	proportional
15	-	-	-	20	15	0-255	Red/Cyan (8 bit) - zone 2 Red LEDs saturation control (0-100%)	proportional
16	-	-	-	21	16	0-255	Red/Cyan fine (16 bit) - zone 2 Fine red LEDs saturation control	proportional
17	-	-	-	22	17	0-255	Green/Magenta (8 bit) - zone 2 Green LEDs saturation control (0-100%)	proportional
18	-	-	-	23	18	0-255	Green/Magenta fine (16 bit) - zone 2 Fine green LEDs saturation control	proportional
19	-	-	-	24	19	0-255	Blue/Yellow (8 bit) - zone 2 Blue LEDs saturation control (0-100%)	proportional
20	-	-	-	25	20	0-255	Blue/Yellow fine (16 bit) - zone 2 Fine blue LEDs saturation control	proportional
21	-	-	-	26	21	0-255	White (8 bit) - zone 2 <i>If RGBW mode is selected:</i> White colour saturation control coarse (0-100%) <i>If CMY mode is selected:</i> No function	proportional
22	-	-	-	27	22	0-255	White (16 bit) - zone 2 Fine white LEDs saturation control (RGBW mode)	proportional
23	-	-	-	28	23	0-255	Red/Cyan (8 bit) - zone 3 Red LEDs saturation control (0-100%)	proportional
24	-	-	-	29	24	0-255	Red/ Cyan fine (16 bit) - zone 3 Fine red LEDs saturation control	proportional
25	-	-	-	30	25	0-255	Green/Magenta (8 bit) - zone 3 Green LEDs saturation control (0-100%)	proportional
26	-	-	-	31	26	0-255	Green/Magenta fine (16 bit) - zone 3 Fine green LEDs saturation control	proportional

Mode/Channel						Value	Function	Type of control
1	2	3	4	5	6			
27	-	-	-	32	27	0-255	Blue/Yellow (8 bit) zone 3 Blue LEDs saturation control (0-100%)	proportional
28	-	-	-	33	28	0-255	Blue/Yellow fine (16 bit) zone 3 Fine blue LEDs saturation control	proportional
29	-	-	-	34	29	0-255	White (8 bit) zone 3 <i>If RGBW mode is selected:</i> White colour saturation control coarse (0-100%) <i>If CMY mode is selected:</i> No function	proportional
30	-	-	-	35	30	0-255	White fine (16 bit) zone 3 Fine white LEDs saturation control (RGBW mode)	proportional
31	15	11	-	10	31	0 1-255	CTC No function Colour temperature correction from 19000K to 2700K	step proportional
32	16	12	7	11	32	0 1-2 3 4-5 6 7-9 10-12 13-15 16 17-55 56 57 - 95 96 97 - 134 135 136 - 174 175 176 -214 215 216 - 246 247	Virtual Colour Wheel For detailed description see " Virtual colour wheel- colour mixing chart No function White 2700 K White 2700 K (Halogen lamp mode*) White 3200 K White 3200 K (Halogen lamp mode*) White 4200 K White 5600 K White 8000 K Blue (Blue=full, Red+Green+White=0) Red=0, Green->up,Blue =full, White=0 Light Blue (Red=0, Green=full, Blue =full, White=0) Red=0, Green=full, Blue->down, White=0 Green (Red=0, Green=full, Blue =0, White=0) Red->up, Green=full, Blue=0, White=0 Yellow (Red=full, Green=full, Blue=0, White=0) Red=full, Green->down, Blue=0, White=0 Red(Red=full, Green=0, Blue=0, White=0) Red=full, Green=0, Blue->up, White=0 Magenta (Red=full, Green=0, Blue=full, White=0) Red -> down, Green=0, Blue=full, White=0 Blue (Red=0, Green=0, Blue=full, White=0)	step step step step step step step step step proportional step proportional step proportional step proportional step proportional step
-	-	-	-	-	33		No function	
-	-	-	-	-	34		No function	
33	17	13	8	7	35	0-31 32-63 64-95 96-111 112-127	Shutter/Strobe Shutter closed Strobe effect from slow-> fast (zones 2,3 only) Strobe effect from slow-> fast (All zones together) -----Set value on Virtual colour wheel----- Zone effects+rainbow effects speed control, slow-> fast Zone effects+rainbow effects speed control, fast-> slow /opposite direction/ -----	step proportional proportional proportional proportional

Mode/Channel						Value	Function	Type of control
1	2	3	4	5	6			
33	17	13	8	7	35	128-143	Shutter/Strobe Opening pulses in sequences from slow--> fast (All zones together) Closing pulses in sequences from fast--> slow (All zones together) Random strobe effect from slow--> fast (random zone) Random strobe effect from slow--> fast (random zone + random strobe) Random strobe effect from slow --> fast (All zones together) Shutter open	proportional
						144-159		proportional
						160-175		proportional
						176-191		proportional
						192-223 224-255		proportional step
34	18	14	9	8	36	0-255	Dimmer (8 bit) Dimmer intensity from 0% to 100%	proportional
35	19	-	-	9	37	0-255	Dimmer fine (16 bit) Fine dimming	proportional

*In the Halogen lamp mode the Dimmer channel imitates behaviour of the halogen lamp during dimming.

5.1 Virtual colour wheel - colour mixing chart

Scale*	Virtual Colour Wheel	Red	Green	Blue	White
	DMX	DMX	DMX	DMX	DMX
1-15	1-2 (White 2700K)	250	118	0	63
	3 (White 2700K /Hal.mode/)	250	118	0	63
	4-5 (White 3200K)	255	141	5	89
	6 (White 3200K /Hal.mode/)	255	141	5	89
	7-9 (White 4200K)	254	141	3	255
	10-12 (White 5600K)	254	207	37	255
	13-15 (White 8000K)	228	255	79	255
16-63	16	0	0	255	0
	17	0	3	255	0
	18	0	6	255	0
	19	0	9	255	0
	20	0	12	255	0
	21	0	15	255	0
	22	0	18	255	0
	23	0	21	255	0
	24	0	24	255	0
	25	0	27	255	0
	26	0	30	255	0
	27	0	36	255	0
	28	0	41	255	0
	29	0	46	255	0
	30	0	52	255	0
	31	0	58	255	0
	32	0	64	255	0
	33	0	68	255	0
	34	0	74	255	0
	35	0	80	255	0
	36	0	86	255	0
	37	0	92	255	0
	38	0	98	255	0
	39	0	104	255	0
	40	0	110	255	0
	41	0	119	255	0
	42	0	129	255	0
	43	0	138	255	0
	44	0	147	255	0
	45	0	156	255	0
	46	0	165	255	0
	47	0	174	255	0
	48	0	183	255	0
	49	0	192	255	0
	50	0	201	255	0
	51	0	210	255	0
	52	0	219	255	0
	53	0	228	255	0
	54	0	237	255	0
	55	0	246	255	0
	56	0	255	255	0
	57	0	255	246	0
	58	0	255	237	0
	59	0	255	228	0
	60	0	255	219	0
	61	0	255	210	0
	62	0	255	201	0
	63	0	255	192	0

Scale*	Virtual Colour Wheel	Red	Green	Blue	White
	DMX	DMX	DMX	DMX	DMX
	64	0	255	183	0
	65	0	255	174	0
	66	0	255	165	0
	67	0	255	156	0
	68	0	255	147	0
	69	0	255	138	0
	70	0	255	129	0
	71	0	255	119	0
	72	0	255	110	0
	73	0	255	104	0
	74	0	255	98	0
	75	0	255	92	0
	76	0	255	86	0
	77	0	255	80	0
	78	0	255	74	0
	79	0	255	68	0
	80	0	255	64	0
	81	0	255	58	0
	82	0	255	52	0
	83	0	255	46	0
	84	0	255	41	0
	82	0	255	36	0
	86	0	255	30	0
	87	0	255	27	0
	88	0	255	24	0
	89	0	255	21	0
	90	0	255	18	0
	91	0	255	15	0
	92	0	255	12	0
	93	0	255	9	0
	94	0	255	6	0
	95	0	255	3	0
	96	0	255	0	0
	97	3	255	0	0
	98	6	255	0	0
	99	9	255	0	0
	100	12	255	0	0
	101	15	255	0	0
	102	18	255	0	0
	103	21	255	0	0
	104	24	255	0	0
	105	27	255	0	0
	106	30	255	0	0
	107	36	255	0	0
	108	41	255	0	0
	109	46	255	0	0
	110	52	255	0	0
	111	58	255	0	0
	112	64	255	0	0
	113	68	255	0	0
	114	74	255	0	0
	115	80	255	0	0
	116	86	255	0	0
	117	92	255	0	0
	118	98	255	0	0

Scale*	Virtual Colour Wheel	Red	Green	Blue	White
	DMX	DMX	DMX	DMX	DMX
	119	104	255	0	0
	120	110	255	0	0
	121	119	255	0	0
	122	129	255	0	0
	123	138	255	0	0
	124	147	255	0	0
	125	156	255	0	0
	126	165	255	0	0
	127	174	255	0	0
	128	183	255	0	0
	129	192	255	0	0
	130	201	255	0	0
	131	210	255	0	0
	132	219	255	0	0
	133	228	255	0	0
	134	240	255	0	0
	135	255	255	0	0
	136	255	246	0	0
	137	255	237	0	0
	138	255	228	0	0
	139	255	219	0	0
	140	255	210	0	0
	141	255	201	0	0
	142	255	192	0	0
	143	255	183	0	0
	144	255	174	0	0
	145	255	165	0	0
	146	255	156	0	0
	147	255	147	0	0
	148	255	138	0	0
	149	255	129	0	0
	150	255	119	0	0
	151	255	110	0	0
	152	255	104	0	0
	153	255	98	0	0
	154	255	92	0	0
	155	255	86	0	0
	156	255	80	0	0
	157	255	74	0	0
	158	255	68	0	0
	159	255	64	0	0
	160	255	58	0	0
	161	255	52	0	0
	162	255	46	0	0
	163	255	41	0	0
	164	255	36	0	0
	165	255	30	0	0
	166	255	27	0	0
	167	255	24	0	0
	168	255	21	0	0
	169	255	18	0	0
	170	255	15	0	0
	171	255	12	0	0
	172	255	9	0	0
	173	255	6	0	0

Scale*	Virtual Colour Wheel	Red	Green	Blue	White
	DMX	DMX	DMX	DMX	DMX
	174	255	3	0	0
	175	255	0	0	0
	176	255	0	3	0
	177	255	0	6	0
	178	255	0	9	0
	179	255	0	12	0
	180	255	0	15	0
	181	255	0	18	0
	182	255	0	21	0
	183	255	0	24	0
	184	255	0	27	0
	185	255	0	30	0
	186	255	0	36	0
	187	255	0	41	0
	188	255	0	46	0
	189	255	0	52	0
	190	255	0	58	0
	191	255	0	64	0
	192	255	0	68	0
	193	255	0	74	0
	194	255	0	80	0
	195	255	0	86	0
	196	255	0	92	0
	197	255	0	98	0
	198	255	0	104	0
	199	255	0	110	0
	200	255	0	119	0
	201	255	0	129	0
	202	255	0	138	0
	203	255	0	147	0
	204	255	0	156	0
	205	255	0	165	0
	206	255	0	174	0
	207	255	0	183	0
	208	255	0	192	0
	209	255	0	201	0
	210	255	0	210	0
	211	255	0	219	0
	212	255	0	228	0
	213	255	0	237	0
	214	255	0	246	0
	215	255	0	255	0
	216	246	0	255	0
	217	237	0	255	0
	218	228	0	255	0
	219	219	0	255	0
	220	210	0	255	0
	221	201	0	255	0
	222	192	0	255	0
	223	183	0	255	0
	224	174	0	255	0
	225	165	0	255	0
	226	156	0	255	0
	227	147	0	255	0
	228	138	0	255	0

Scale*	Virtual Colour Wheel	Red	Green	Blue	White
	DMX	DMX	DMX	DMX	DMX
	229	129	0	255	0
	230	119	0	255	0
	231	110	0	255	0
	232	104	0	255	0
	233	98	0	255	0
	234	91	0	255	0
	235	84	0	255	0
	236	77	0	255	0
	237	70	0	255	0
	238	63	0	255	0
	239	56	0	255	0
	240	49	0	255	0
	241	42	0	255	0
	242	35	0	255	0
	243	28	0	255	0
	244	21	0	255	0
	245	14	0	255	0
	246	7	0	255	0
	247	0	0	255	0
	248-255 (Rainbow+ zone effects)	****	****	****	****

* Colour scale as an illustration only

5.2 LED zone order

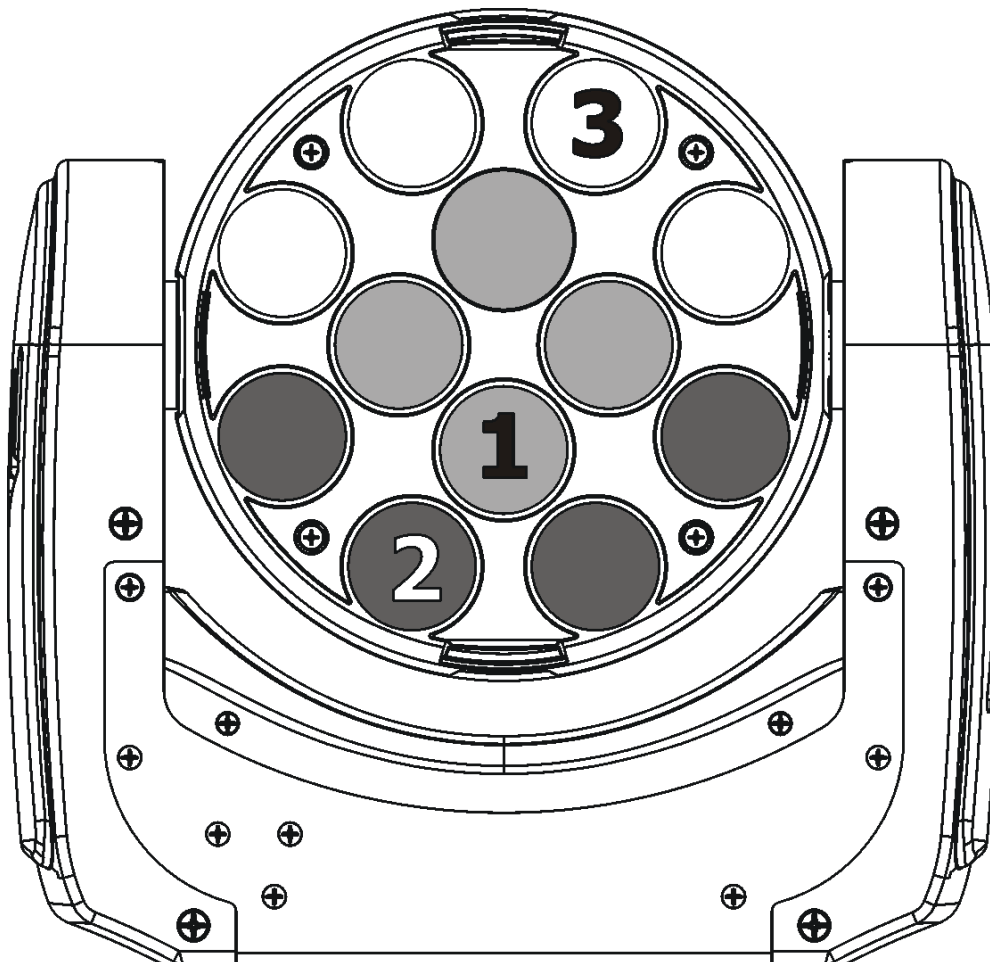

6. Control menu

The Robin 100 LEDBeam is equipped with 2-row LCD display which allows to set the fixture's behaviour according to your needs, obtain information on its operation, test its various parts and lastly program it, if it has to be used in a stand-alone mode.

Control panel:

[ESCAPE] button used to leave the menu without saving changes.

[NEXT] , [PREV] buttons for moving between menu items and for value adjusting.

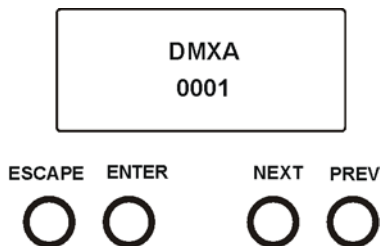

[ENTER] button used to enter the selected menu (menu item) and to confirm adjusted value.

After switching the fixture on, display shows current DMX address.

6.1 Addressing (DMXA)

Set DMXA- Use this menu item to set the DMX start address of the fixture, which is defined as the first channel from which the Robin 100 LEDBeam will respond to the controller.

If you set, for example, the address 36, the Robin 100 LEDBeam will use channels 36 - 70 for control (if Mode 1 is selected).

Please, be sure that you do not have any overlapping channels in order to control each Robin 100 LEDBeam correctly and independently from any other fixture on the DMX data link.

If there is no data received at the DMX input, the display will start to flash "0001" with actually stored DMX address.

6.2 Fixture information (Info)

Pon Time - **Power on time**. Select this menu to read the number of fixture operation hours.

Total - The item shows the total number of the operation hours since the Robin 100 LEDBeam has been fabricated.

Reset - The item shows the number of the operation hours that the Robin 100 LEDBeam has been powered on since the counter was last reset.

In order to reset this counter to 0, press and hold both [NEXT] and [PREV] buttons and the [Enter] button at the same time.

DMX In - **DMX readout**. The menu is used to read DMX values of each channel received by the fixture.

Temp - **Temperature**. The menu shows temperature in the LED module.

Current - A current temperature of the LED module.

Highest - A maximum temperature of the the LED module since the fixture has been fabricated.

High Res - A maximum temperature of the the LED module since the counter was last reset.

In order to reset this counter, press and hold both [NEXT] and [PREV] buttons and the [Enter] button at the same time.

Sw Ver - **Software versions**. Select this item to read the software version of the fixture modules.

IC-1 - A pan/Tilt processor.

IC-2 - A display processor.

IC-3 - LED control processor.

6.3 Personality (Pers)

DMX Pres - DMX preset. Use the menu to select desired channel mode.

Mode 1 - 35 control channels

Mode 2 - 19 control channels

Mode 3 - 14 control channels

Mode 4 - 9 control channels

Mode 5 - 35 control channels

Mode 6 - 37 control channels (equivalent to the LEDWash 300/600 in mode 1)

Pan Rev - Pan reverse. The item allows to invert pan movement.

Tilt Rev - Tilt reverse. The item allows to invert tilt movement.

P/T Mode - Pan and Tilt movement mode. Use this menu to set mode of the pan/tilt movement.

Speed - Both Pan and tilt will move with the same speed as adjusted at the channel 5 "Pan/Tilt speed, Pan/Tilt time".

Time - The pan and tilt will move with different speeds and they will come at the same time to the end point of their tracks (pan and tilt use their optimal speeds).

Time of the pan/tilt movement (25.5 sec. max.) is set by the channel "Pan/Tilt speed, Pan/Tilt time".

P/T Feed - Pan and Tilt Feedback. The menu item allows to return the mowing head to the required pan/tilt position after changing the position by an external force if this option is set on.

Note. The Pan/Tilt Feedback should be permanent On, the option Off is not suitable for standard operation and the head of the fixture can be damaged!

Tilt Red - Tilt movement reduction. Use this menu to set the range of the tilt movement of the fixture head

Off - Standard range: 0-300°.

On - Reduced range: 0-210°. This option must be set before top hat placing otherwise the top hat will run into fixture's yoke.

Display - Display adjusting. This menu allows you to adjust the display behaviour.

Turn - This function turns the display by 180°.

On/Off T - This function allows you to keep the display permanent on or turn it off two minutes after last pressing any button on the control panel.

Contrast - Use this function to adjust contrast of the display (0-100%).

Backlight - Use this function to adjust backlight of the display (0-100%).

BLC DMC - Blackout during movement correction. Set this option on if you wish to close light output during the time when the head goes to its correct position, which has been changed by an external force.

Act Blc - Active blackout. Use this menu if you wish to close the light output during effect changes.

P/T Mov - The menu item allows to close light output while the pan/tilt coordinates are changing.

C Cal M - Colour calibration mode. If the function is on, the white output (R+G+B+W=full) from the fixture (and also mixed colours) is more uniform. Each colour is dynamically corrected according to the value set in the menu "Calibrate Effects" (Special-> Adjust-> Calib).

C Mix M - Colour mixing mode. This item allows switching into RGBW or CMY mode. In the CMY mode, the white(8bit)/white (16) bit channels are not active.

Mic Sens - Microfon sensitivity. Enter the menu if you want to adjust the microphone sensitivity (1-max., 19-min.).

Fans - Fan mode. Use the menu to set the fixture fans to max. fan power mode ("**High**") or to auto- control mode ("**Auto**").

Temp Uni - Temperature unit. Use the menu item to change temperature unit from °C to °F.

I Ef Pos - Init effect positions. Use the menu to set all effects to the desired positions at which they will stay after switching the fixture on without DMX signal connected.

Defaults - The menu item allows to set all fixture parameters to the default (factory) values.

6.4 Manual Control (Manual)

Pres Eff - Preset effects. Use the menu to show preset positions of each channel effect.

Manual C - Manual control. Use the menu to control all fixture channels by means of the control panel.

6.5 Test program (Test Prg)

Use this menu to run a special demo-test sequences without an external controller, which will show you some possibilities of using Robin 100 LEDBeam.

Static - Static mode. This mode is suitable for projections on the wall, ceiling or ground without any head movement.

Dynamic - Dynamic mode. This mode uses all Robin 100 LEDBeam functions including pan/tilt movement and therefore is good for a complete introduction of the fixture.

6.6 Stand-alone (St Alone)

Music T - Music trigger. Select this function to enable the sound control of the running program via the built-in microphone.

Auto Run - Presetting playback. This function allows you to select the program which will be played in the stand-alone mode after switching the fixture on. Selected program will be played continuously in a loop.

Off - The option disables „Auto Run” function.

Test - The option will start built-in test program.

Prog 1 - The option will start user-created program 1

Prog 2 - The option will start user-created program 2

Prog 3 - The option will start user-created program 3

Pr Play - Playing program. Select this menu to run a user-created program in a loop.

Test Prg - The option runs built-in test program.

Prog 1 - The option runs user-created program 1

Prog 2 - The option runs user-created program 2

Prog 3 - The option runs user-created program 3

Select the program you wish and press [ENTER]. The selected program starts running. By Pressing [ENTER] again, program pauses running.

Pr Edit - Editing program. Select this menu to edit or create the program. The Robin 100 LEDBeam has one built-in program and one user-editable program up to 40 steps. Each program step has a step time - during which effects last in the current step and a fade time- during which effects move to new positions.

To edit program:

Procedure:

1. Press [NEXT] or [PREV] to select the menu "Edit" and press [ENTER].
2. Press [NEXT] or [PREV] to select the desired program step and press [ENTER] button.
3. Press [NEXT] or [PREV] to select the desired item and press [ENTER] button. Now you can edit by [NEXT] or [PREV] buttons the DMX value (0-255) for selected item:

Prg End.	a total number of the program steps (value 1-40). This value you should be set before starting of programming (e.g. if you want to create program with the 10 steps, set Prg End=10).	CTC	a colour temperature correction
PAn	a coarse pan movement	Virt C	a virtual colour
PAn F	a fine pan movement	Strob	a strobe/shutter
Tilt	a coarse tilt movement	Dimmer	a dimmer coarse
Tilt F	a fine tilt movement	Dimm F	a dimmer fine
P/T Sp	a pan/tilt speed	F.Tim	a fade time (0-25.5 sec)
Power	power/special functions	S.Tim	a step time (0-25.5 sec)
R Led 1 (2/3)	red coarse -zone 1 (2,3)	COPY	copying the current prog. step to the next prog. step
G Led 1 (2/3)	green coarse - zone 1(2,3)		
B Led 1 (2/3)	blue coarse - zone 1(2,3)		
W Led 1 (2/3)	white coarse - zone 1(2,3)		

4. Press [ENTER] button to confirm adjusted value .

5. Press [ESCAPE] button, select next prog. step, press [ENTER] button and repeat steps 3 - 5).

6.7 Reset

This option enables the Robin 100 LEDBeam to index all effects and return to their standard positions.

6.8 Special functions (Special)

RDM Low - This menu item shows the first part of the RDM identification code.

RDM High - This menu item shows the second part of the RDM identification code.

Wireless - **Wireless DMX information.** The menu allows to read some information about Wireless DMX operation

Stat - Wireless status. Use the menu to read wireless DMX status.

Unlink - use this item to unlink fixture from wireless DMX.

Adjust - Adjustment. The menu allows the fine adjustment of effects.

DMX Val- DMX values. Use the menu to set DMX values of fixture's channels.

Calib - calibration of white colour.

Cal P/T - Use this menu to calibrate pan/tilt positio.

Cal Col - Use this menu to set white colour 5600K.

Calibration of the pan/tilt via the control board

1. Disconnect DMX controller from the fixture and enter the "Cal P/T" menu.
2. Use the [PREV] and [NEXT] to find "Pan" and press [ENTER].
3. Set desired value and save it by pressing [ENTER].
4. Repeat steps 2 and 3 for Tilt.
5. After calibrating both effects, find item "Store" and press [ENTER]. to save all adjusted values and reset the fixture.

Calibration of the white 5600K via the control board

1. Disconnect DMX controller from the fixture , open the sShutter and Dimmer and set the Virtual colour wheel channel at DMX=10 (white 5600K). Aim the light beam on the lux meter (e.g. Minolta CL-200A Chroma meter) which is placed cca 5m from the fixture.
2. Set the menu item Colour Calibration Mode to On (Pers-> C Cal M -> On).
3. Enter the menu "Cal Col".
4. Use the [NEXT] or [PREV] button to select desired colour and press the [ENTER] button.
5. Use the [NEXT] or [PREV] button to set desired value of colour.
5. By means of the "Red C, Grn C, Blue C and Whi C" items adjust the 5600K colour temperature as exactly as possible ($\Delta u'v' = 0$).
7. After adjusting 5600K colour temperature, select item Store and press the [ENTER] button to save all adjusted values .

Note: you can also use DMX controller for both calibrations stated above, calibration protocol is the following:

Effect	Mode 1	Mode 2	Mode 3	Mode 4	Mode 5
Pan-fine adjustment	channel 36	channel 20	channel 15	channel 10	channel 36
Tilt - fine adjustment	channel 37	channel 21	channel 16	channel 11	channel 37
Red - red saturation	channel 38	channel 22	channel 17	channel 12	channel 38
Green- green saturation	channel 39	channel 23	channel 18	channel 13	channel 39
Blue - blue saturation	channel 40	channel 24	channel 19	channel 14	channel 40
White - white saturation	channel 41	channel 25	channel 20	channel 15	channel 41

Cal Load - Loads default (factory) calibration.

Sw Upd - Software update. The menu item allows you to update software in the fixture via either serial or USB port of PC.

The following are required in order to update software:

- PC running Windows 95/98/2000/XP/7 or Linux
- Update software
- Flash cable RS232/DMX No.13050624 (if you want to use a serial port of PC)
- Robe Universal Interface (if you want to use an USB port of PC)

Note 1: Software update should execute a qualified person. If you lack qualification, do not attempt the update

yourself and ask for help your ROBE distributor.

Note 2: DMX address, , programs 1-3 and all items in the menu "Pers" will be set to their default (factory) values after software update.

To update software in the fixture:

I. Installation of the update software.

1. Update Software available from the ROBE web site at WWW.robe.cz.
2. Make a new directory (e.g. Robe_Uploader) on your hard disk and download the software to it.
3. Unpack the program to the directory.

II. Fixture software updating.

1. Determine which of your ports is available on your PC and connect it:
 - with the DMX input of the fixture if you using the flash cable RS232/DMX
 - with the USB input of the Robe Universal Interface if you using the USB cable. Connect DMX output of the Robe Universal Interface with the fixture via a standard DMX cabel.
 Turn both the computer and the fixture on. Make sure the lamp is switched off (only if the fixture has a lamp).

2. Switch the fixture to the updating mode (Special -> "SW Upd "-> On).

Note: If you do not want to continue in software update, you have to switch off and on the fixture to escape from this menu.

We recommend to cancel all running programs on PC before starting the software update.

3. Run the Software Uploader. Select desired COM and then click on the Connect button.

(Select COM if the serial port is used or Robe Universal Interface if the USB port is used).

If the connection is OK, click on the "Start Uploading button" to start uploading. It will take several minutes to perform software update.

If the option "Incremental Update" is not checked, all processors will be updated (including processors with the same software version).

If you wish to update only later versions of processors, check the "Incremental Update box".

Avoid interrupting the process. Update status is being displayed in the Info Box window.

When the update is finished, the line with the text "The fixture is successfully updated" will appear in this window and the fixture will reset with the new software.

Note: In the case of an interruption of the upload process (e.g. power cut), the fixture keeps the updating mode and you have to repeat the software update again.

7. RDM

This fixture supports RDM operation. RDM (Remote Device Management) is a bi-directional communications protocol for use in DMX512 control systems, it is the new open standard for DMX512 device configuration and status monitoring.

The RDM protocol allows data packets to be inserted into a DMX512 data stream without adversely affecting existing non-RDM equipment. By using a special „Start Code,“ and by complying with the timing specifications for DMX512, the RDM protocol allows a console or dedicated RDM controller to send commands to and receive messages from specific moving lights.

RDM allows explicit commands to be sent to a device and responses to be received from it.

The list of commands for Robin 100 LEDBeam is the following.

Parameter ID	Discovery command	SET command	GET command
DISC_UNIQUE_BRANCH	*		
DISC_MUTE	*		
DISC_UN_MUTE	*		
DEVICE_INFO			*
SUPPORTED_PARAMETERS			*
SOFTWARE_VERSION_LABEL			*
DMX_START_ADDRESS		*	*
IDENTIFY_DEVICE		*	*
DEVICE_MODEL_DESCRIPTION			*
MANUFACTURER_LABEL			*
DEVICE_LABEL		*	*
SENSOR_DEFINITION			*

SENSOR_VALUE			*
DISPLAY_INVERT		*	*
DISPLAY_LEVEL		*	*
PAN_INVERT		*	*
TILT_INVERT		*	*
DEVICE_RESET		*	
DMX_PERSONALITY		*	*
DMX_PERSONALITY_DESCRIPTION			*
STATUS_MESSAGES			*
STATUS_ID_DESCRIPTION			*
DEVICE_HOURS			*
PARAMETER_DESCRIPTION			*
ROBE_DMX_INPUT		*	*
ROBE_WIRELESS_UNLINK		*	

8. Error and information messages

Short Err

The message informs you that short circuit has occurred on the LED PCB.

Tilt Err

This message will appear after the reset of the fixture if the head's magnetic-indexing circuit malfunctions (sensor failed or magnet is missing) or the stepping motor is defective or its driving IC on the PCB. The head is not located in the default position after the reset.

9. Technical Specifications

Electrical

Power supply:.....electronic auto-ranging

Input voltage range:..... supply 100-240V, 50-60Hz

Fuse:.....T 3.15A/250V ~

Power consumption *:.....200W@230V,I=0.89A, power factor=0.96 (R+G+B+W=full)

200W@208V,I=0.99A, power factor=0.96 (R+G+B+W=full)

200W@110V,I=1.9A, power factor=0.94 (R+G+B+W=full)

*Allow for a deviation of +/-10%

Optic

Light source: 12 Osram Ostar RGBW multichips (SMT LE RTDUW S2W)

3 zones with individual colour control of each

Min LED life expectancy: 20.000 hours

RGBW colour mixing +CTO

Beam angle: 7°

Virtual colour wheel

237 colours including whites (2700K, 3200K, 4200K, 5600K and 8000K)

Halogen lamp effect at whites 2700K and 3200K

Rainbow effect with in both directions with variable speed

Zone effects in both directions with variable speed

Strobe

All LED zones together:
Strobe effect with variable speed (0.3 - 20Hz)
Random strobe pulse-effect with variable speed
Opening/closing pulse effect with variable speed
Independent strobe effect with variable speed (0.3 - 20Hz) at zones 2+3
Random strobe and random LED zone effect

Dimmer

Smooth dimmer from 0 - 100 %

Pan/Tilt

Max. pan movement range: 450°
Max. tilt movement range: 300° (280° reduced)
16 bit movement resolution
Automatic Pan/Tilt position correction
Remotely controllable speed of pan/tilt movement for easy programming
Movement control: tracking and vector
Pan movement 0° - 450° at max. speed: 1 sec.
Tilt movement 0° - 300° at max. speed: 0.5 sec.

Control

2-row LCD display & 4 buttons
Readout fixture usage, receiving DMX values, temperatures, etc
Built-in analyzer for easy fault finding, error messages
Built-in demo sequences
Silent fans cooling,
Stand-alone operation
3 user editable programs, each up to 40 steps
Supported protocols: USITT DMX 512, RDM,
Support of RDM (Remote Device Management)
6 DMX modes (35, 19, 14, 9, 35, 37 control channels)

External Wireless DMX/RDM module (option)

Compliance with USITT DMX-512 (1986 & 1990) and 512-A
Full DMX fidelity and frame integrity
Auto sensing of DMX frame rate and frame size
<5ms DMX latency
Operational frequency range of 2402-2480 MHz
Producer: LumenRadio

Connection

DMX data in/out: Locking 5-pin XLR
AC power input: Chassis connector Neutrik PowerCon, A-type, NAC3MPA
AC power output: Chassis connector Neutrik PowerCon, B-type, NAC3MPB

Rigging

Mounting points: pair of 1/4-turn locks
Mounting horizontally or vertically via Omega holder

Temperatures

Maximum ambient temperature : 45° C
Maximum housing temperature : 80° C

Distances

Min. distance from flammable surfaces: 0.4 m
Min. distance to lighted object: 0.8 m

Total heat dissipation

680 BTU/h (calculated)

Weight (net):

4.5 kg

Dimensions (mm)

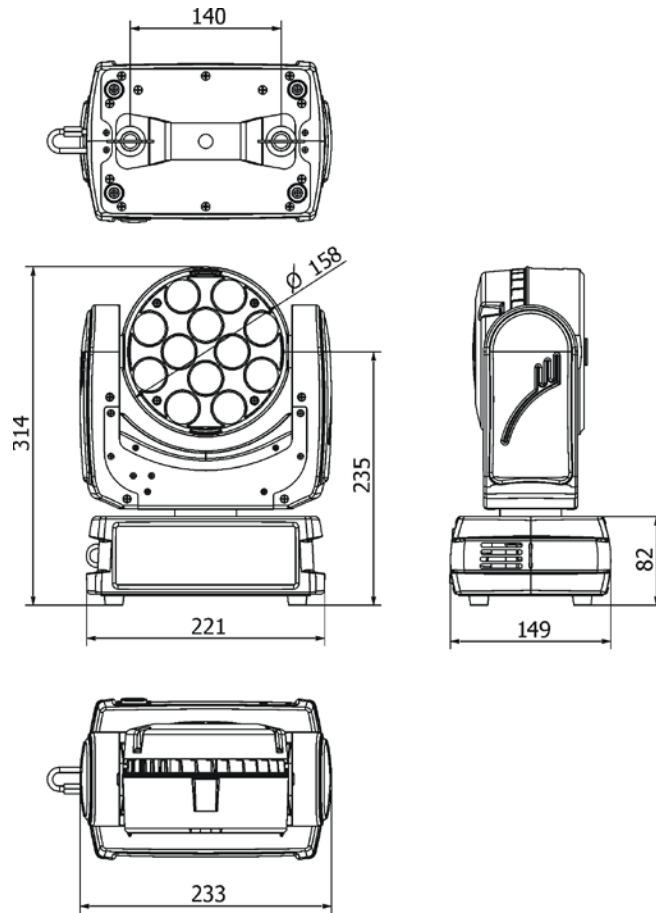

Wireless DMX module: Robe Wireless CRMX-LB100

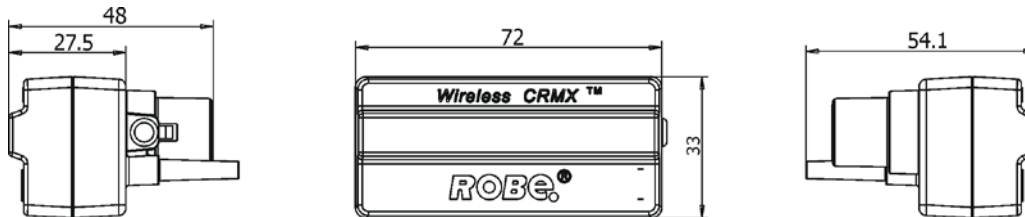

Accessories

Omega holder (P/N 99010420).....1 piece

Optional accessories

- (P/N 10980127) Robe Wireless CRMX-LB100
- (P/N 1098 0118) Top hat (black)
- (P/N 1098 0123) Diffusion filter 40°
- (P/N 1098 0122) Diffusion filter 20°
- (P/N 1098 0194) Diffusion filter 10°

- (P/N1305 1731) Mains Cable PowerCon In/open ended, 2m
- (P/N 1305 1724) Mains Cable PowerCon In/Schuko, 2m
- (P/N 1305 1725) Mains Cable PowerCon In/CEE 16A, 2m
- (P/N 1305 1726) Mains Cable PowerCon In/US, 2m
- (P/N 1305 1727) Daisy Chain PowerCon In/Out, EU, 2m
- (P/N 1305 1728) Daisy Chain PowerCon In/Out, US, 2m

10. ChangeLog

This section summarizes all types of changes in the user manual.

Version of the manual	Date of issue	Description of changes
1.3	15/5/2012	Added chapter "Installation of diffusion filters"
1.4	18/7/2012	Added photometric diagrams for diffusion filters 20° and 40°
1.5	3/12/2012	Added chapter 3.6 Wireless DMX operation
1.6	27/01/2014	Change in the chapter "Installing diffusion filter"
1.7	05/03/2014	Added 10° diffusion filter photometric diagram

11. Maintenance and cleaning

DANGER !
Disconnect from the mains before starting any maintenance work

A soft lint-free cloth moistened with any good glass cleaning fluid is recommended, under no circumstances should alcohol or solvents be used!

Never use alcohol or solvents for cleaning lenses in the moving head!
Use wet cloth only.

It is absolutely essential that the fixture is kept clean and that dust, dirt and smoke-fluid residues must not build up on or within the fixture. Otherwise, the fixture's light-output will be significantly reduced. Regular cleaning will not only ensure the maximum light-output, but will also allow the fixture to function reliably throughout its life. A soft lint-free cloth moistened with any good glass cleaning fluid is recommended, under no circumstances should alcohol or solvents be used!

Lenses may require monthly cleaning as smoke-fluid tends to building up residues, reducing the light-output very quickly. The cooling fans should be cleaned according to the situation (at least annually). The interior of the base should be cleaned at least annually using a vacuum-cleaner or an air-jet.

More complicated maintenance and service operations are only to be carried out by authorized distributors.

11.1 Replacing fuse

1. Replace the fuse by a fuse of the same type and rating only.

Before replacing the fuse, unplug mains lead!

2. Remove the plastic covers of the base (3) by unscrewing 5 fastening screws (1) and (2) on each cover.

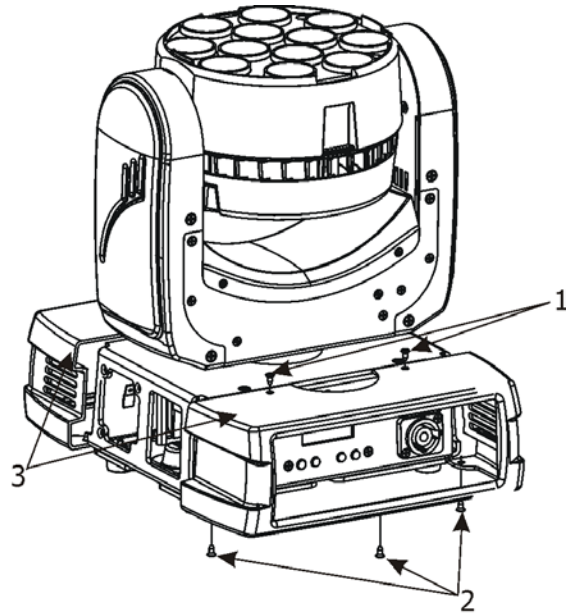

3. Unscrew four screws (4) on the top chassis (5). Lay down the fixture and unscrew four screws (6) on the bottom plate (9) to push out inside module of the base.

4. Unscrew two screws (8) on the bottom plate to remove rear panel of the fixture (7).

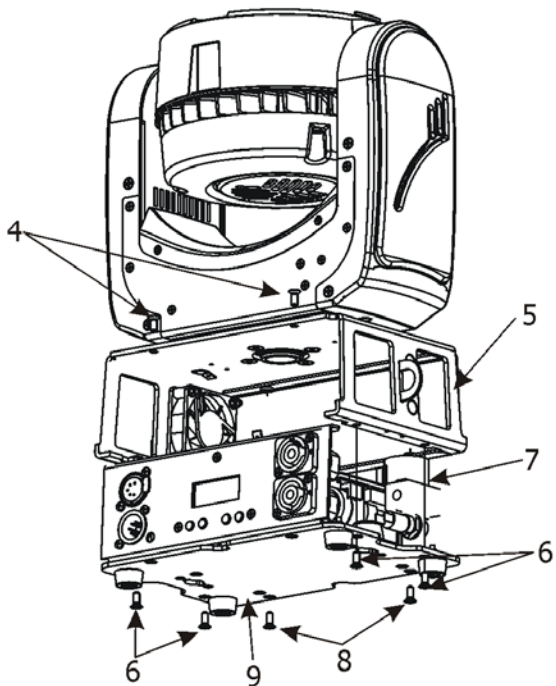

5. Now you have access for the fuse holder (10) in the inside module of the base.

6. Remove the old fuse from the fuseholder.

7. Install the new fuse into the fuseholder.

8. Assemble the base of the fixture.

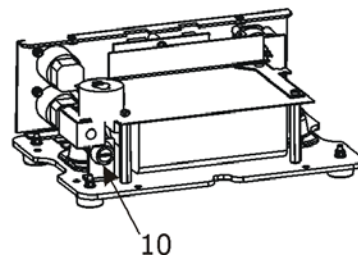

12. Photometric diagrams

Beam angle 7°

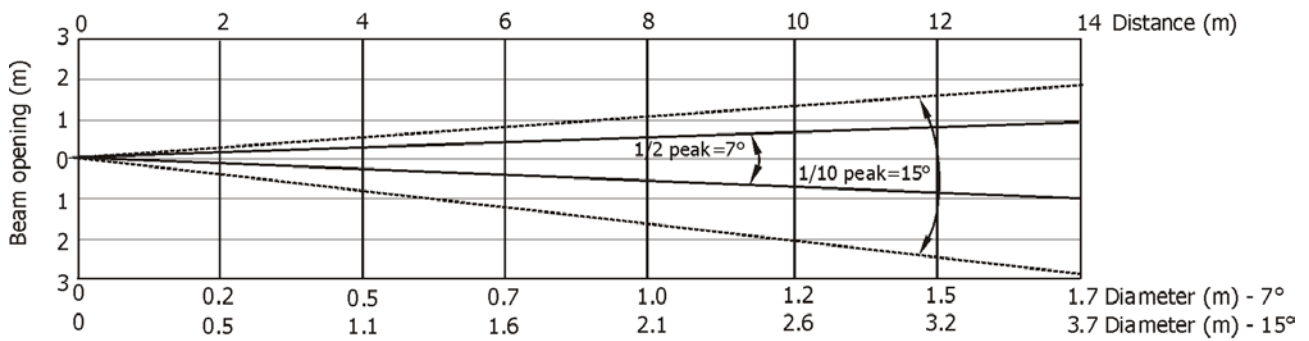

Distance (m)	2	4	5	6	8	10	12	14	
Red	7125/662	1781/166	1140/106	792/74	445/41	285/27	198/18	145/14	Intensity (center) Lux/Footcandles
Green	15188/1411	3797/353	2430/226	1688/157	949/88	608/56	422/39	310/29	
Blue	2000/186	500/47	320/30	222/21	125/12	80/7	56/5	41/4	
White	20125/1870	5031/467	3220/299	2236/208	1258/117	805/75	559/52	411/38	
R+G+B+W	37250/3461	9313/865	5960/554	4139/385	2328/216	1490/138	1035/96	760/71	

Illuminance distribution

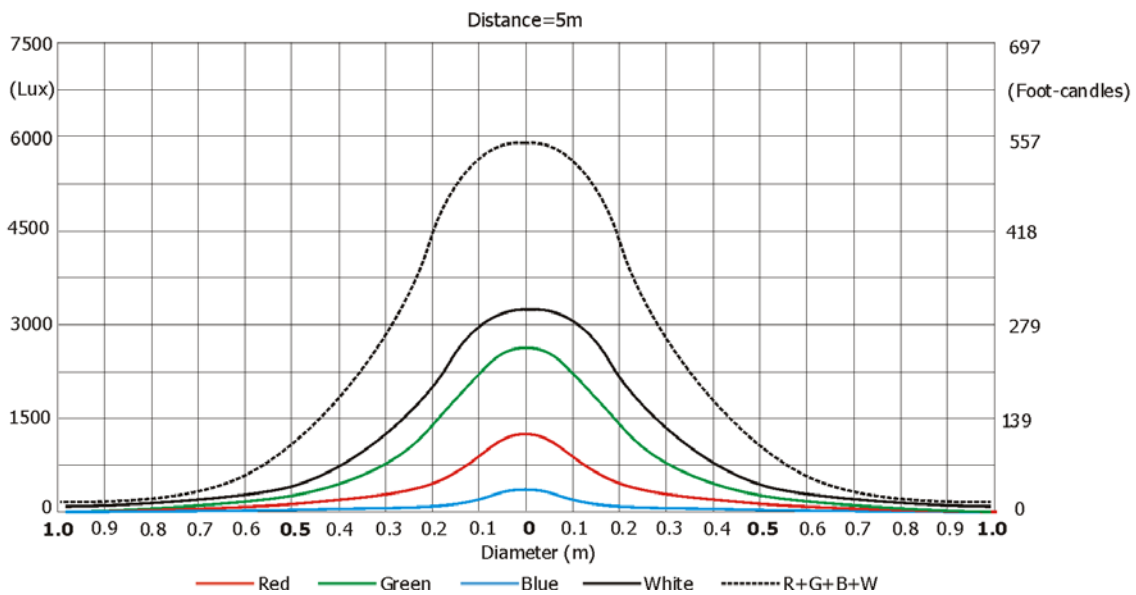

Specifications are subject to change without notice.
March 5, 2014

Diffusion filter 10°

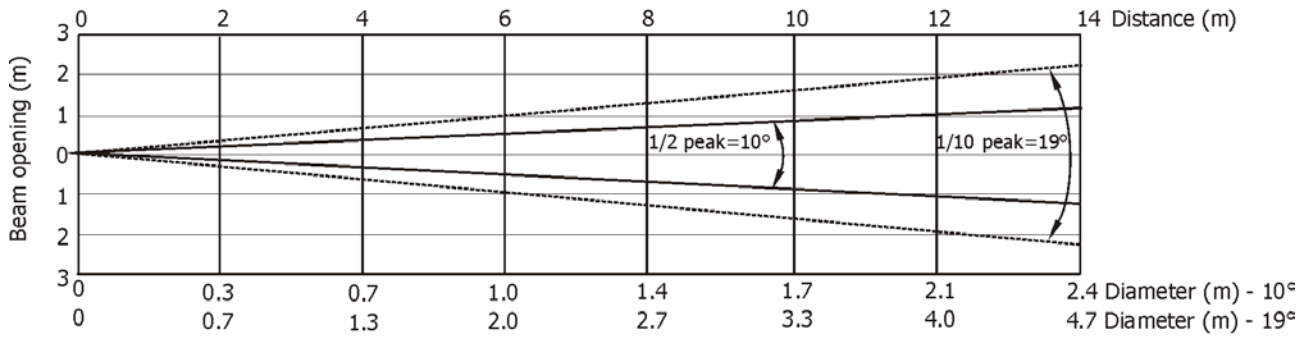

Distance (m)	2	4	5	6	8	10	12	14	
Red	4625/430	1156/107	740/69	514/48	289/26	185/17	128/12	94/9	Intensity (center) Lux/Footcandles
Green	8312/772	2078/193	1330/124	924/86	520/48	333/31	231/22	170/16	
Blue	1069/99	267/25	171/16	118/11	67/6	43/4	30/2.8	22/2	
White	11000/1022	2750/255	1760/164	1222/114	688/64	440/41	305/28	225/21	
R+G+B+W	21625/2009	5406/502	3460/321	2402/223	1351/126	865/80	600/56	441/41	

Illuminance distribution

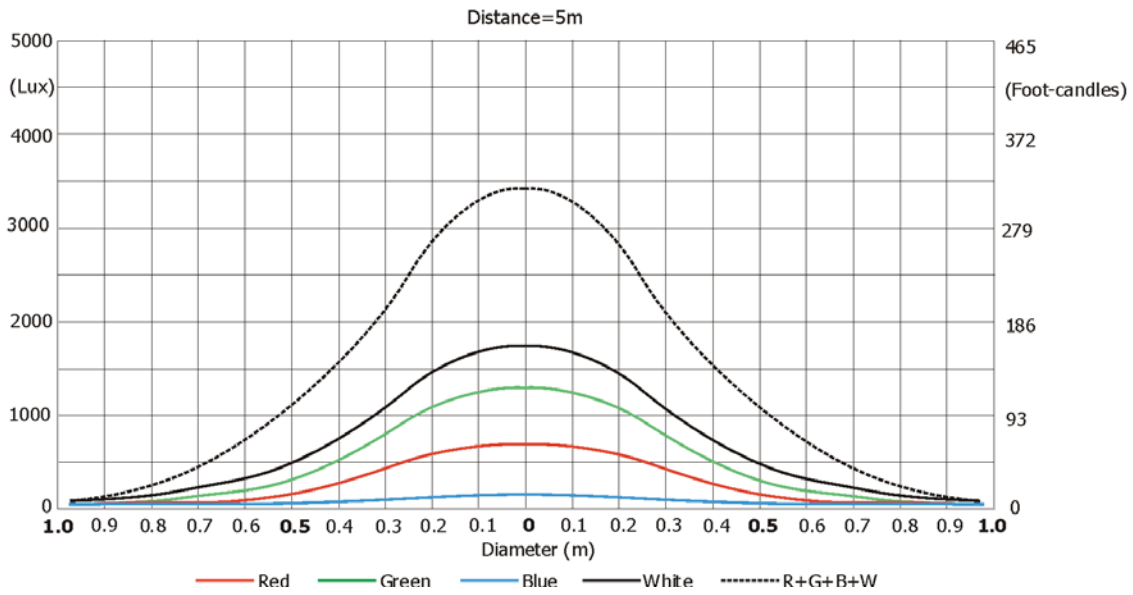

Diffusion filter 20°

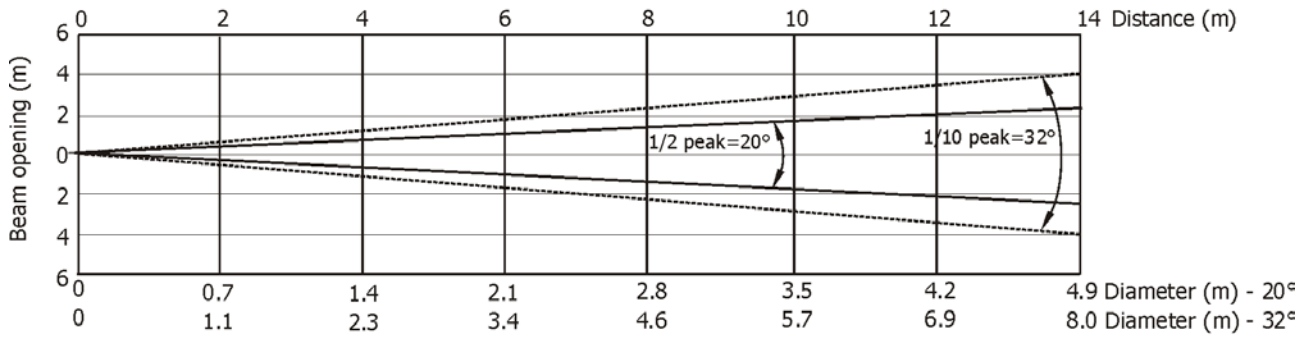

Distance (m)	2	4	5	6	8	10	12	14	
Red	831/77	208/19	133/12	92/9	52/5	33/3	23/2.1	17/1.6	Intensity (center) Lux/Footcandles
Green	2100/195	525/49	336/31	233/22	131/12	84/8	58/5.4	43/4	
Blue	81/7.5	20/1.9	13/1.2	9/0.8	5/0.5	3.3/0.3	2.3/0.2	1.7/0.2	
White	2625/244	656/61	420/39	292/27	164/15	105/9	73/7	54/5	
R+G+B+W	6375/499	1344/125	860/80	597/56	336/32	215/20	149/14	110/10	

Illuminance distribution

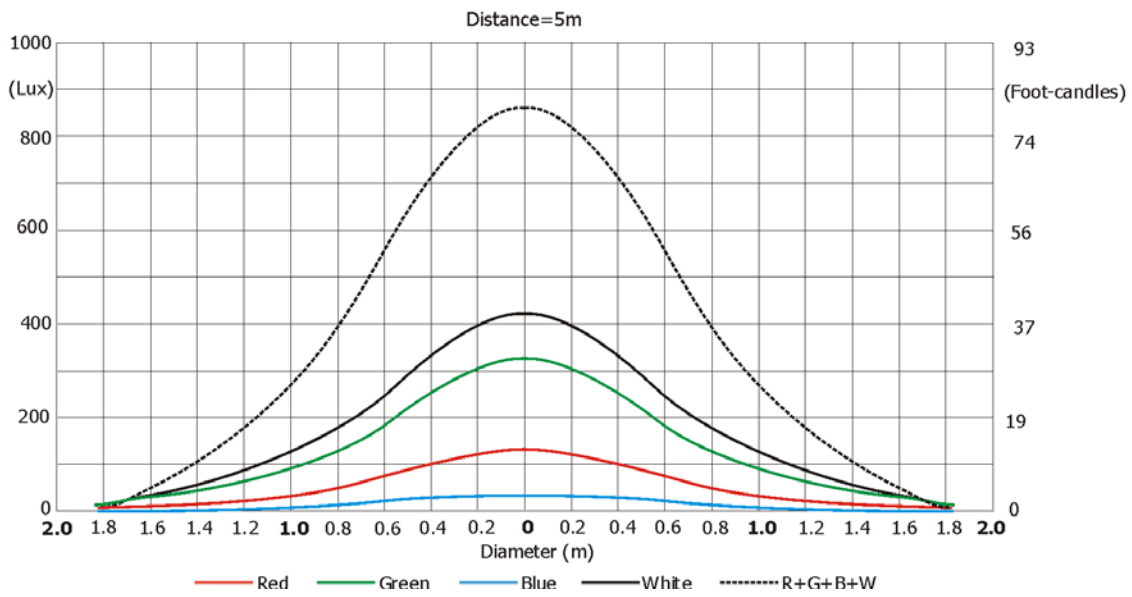

Diffusion filter 40°

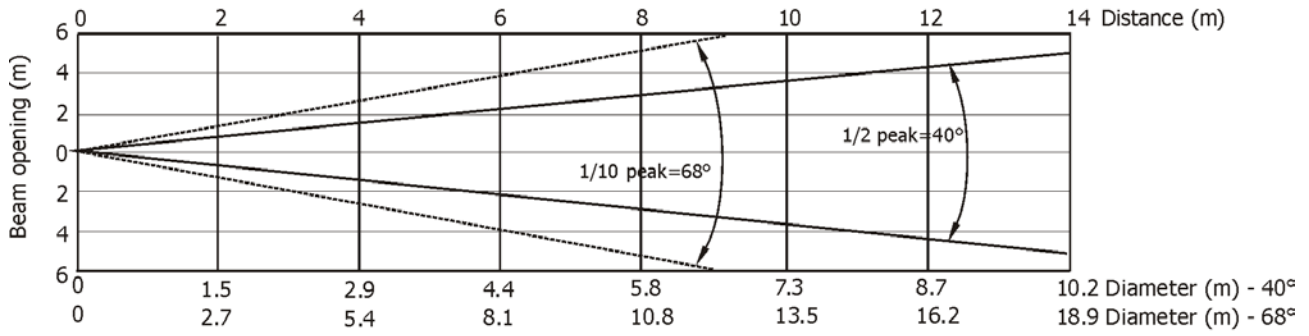

Distance (m)	2	4	5	6	8	10	12	14	
Red	219/20	55/5	35/3.3	24.3/2.3	14/1.3	9/0.8	6/0.6	5/0.4	Intensity (center) Lux/Footcandles
Green	513/48	128/12	82/8	57/5	32/3	21/2	14/1.3	11/1	
Blue	50/4.6	13/1.2	8/0.7	6/0.5	3/0.3	2/0.2	1.4/0.1	1/0.1	
White	725/67	181/17	116/11	81/8	8/45	29/2.7	20/2	15/1.4	
R+G+B+W	1438/133	359/33	230/21	160/15	90/8	58/5	40/4	30/2.7	

Illuminance distribution

